

Using the Cardiovascular System to Illustrate Fundamental Laws and Principles in a Freshman Course

Douglas Christensen, Richard Rabbitt
Department of Bioengineering, University of Utah, Salt Lake City, Utah

Abstract –

Our Fundamentals of Bioengineering I course is organized around key physical and engineering laws and principles. A semester-long Major Project is assigned which integrates many of these principles by modeling the human systemic cardiovascular system, using both Matlab computer analysis and assembly of an analogous electrical circuit.

Background –

The new undergraduate degree program in biomedical engineering at the University of Utah accepted its first freshman class in fall 1999. An integral part of the curriculum is a sequence of two courses in the freshman year, Fundamentals of Bioengineering I and II, whose purpose is to expose the students to the field of bioengineering as well as to introduce some important scientific, engineering and physiological topics which help lay the foundation for later courses. Laboratory experiences in the form of a Major Project are included in each course. The first semester course covers biomechanical, bioelectrical, instrumentation and computer topics; the second semester covers biochemical, metabolic, cellular, and integrative (e.g., biosensors) subject material.

We decided to organize the first semester course around approximately 14 important physical and engineering laws and principles which are pertinent to biomechanics, bioelectricity and instrumentation. We chose this approach because we believe that the best foundation for further studies in biomedical engineering is formed when students learn and practice basic principles which underlie the field.^{1,2} The laws and principles we selected, and the order in which they are presented, are given in Table I.

Table I – Laws and Principles Covered in the Course Units

1. Darcy's Law (membranes)	9. Kirchhoff's Laws (circuit analysis)
2. Poiseuille's Law (flow through tubes)	10. Operational Amplifiers (gain, feedback)
3. Hooke's Law (elasticity and compliance)	11. Coulomb's Law (capacitors, fluid analogs)
4. Starling's Law (cardiac adjustment)	12. Thevenin Equivalent (1 st -order time constants)
5. Euler's Method (finite-difference solutions)	13. Nernst Potential (cell membranes)
6. Muscle, Force and Leverage	14. Fourier Series
7. Work, Energy and Power	
8. Ohm's Law (current, voltage, resistance)	

Written Unit Material –

We found no textbook that presented the material quite in the form we desired, so we wrote a series of notes covering each topic. The level of the material assumes that the students are skilled in algebra, have had some physics and chemistry in high school, and are concurrently enrolled in a Calculus I (or higher) course. This is appropriate for nearly all of our incoming freshman class. After being used for a couple of years, the notes have evolved into a complete set of “units,” one for each topic in Table I, and each taking about a week to cover in the lecture portion of the class. Homework sets are assigned with each unit, and when homework and examples are included, the units are about at the stage of a standard textbook.

The Major Project: Modeling the Cardiovascular System –

To tie many (about 80%) of the course’s topics together and to give the students some hands-on experience with the principles, a semester-long Major Project is assigned which models the human systemic cardiovascular (CV) system. During the first half of the semester, the students individually do computer modeling of the pressure waveforms around the systemic loop; then during the second half, in teams of two, they assemble and measure an electrical circuit simulating the same system, as discussed in more detail below.

Following an explanation of the role that approximations play in engineering modeling, a common model diagram, shown in Fig. 1, is given to all the students. The assigned project models only the systemic portion of the system, ignoring the pulmonary circuit, and represents the left heart by only a single chamber—the ventricle (including both the mitral and aortic valves). The systemic CV loop is broken into five segments, each with compliance and resistance values which each student calculates using physiological tables and graphs that are provided.

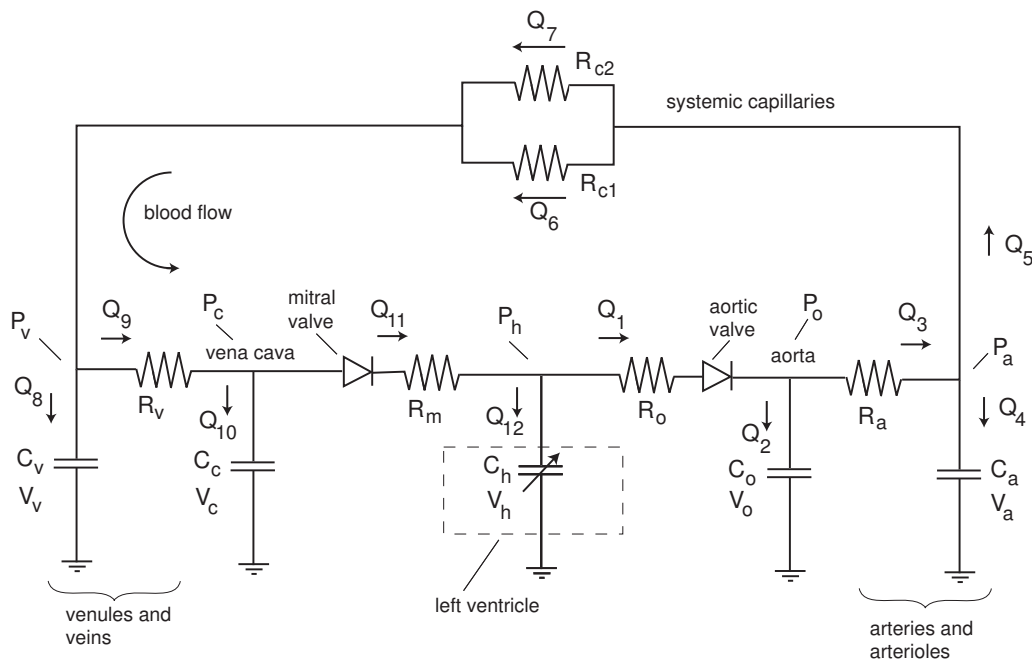

Fig. 1 - Simple model of systemic cardiovascular system.

Computer Modeling – In the first portion of the Major Project, the students (working individually) write finite-difference forms (using Euler’s method) of the differential equations relating pressure changes to volume changes in each compliant vessel (a form of Hooke’s law), and use the generalized Poiseuille’s law to relate pressure drop to volumetric flow through each resistive element. The principle of conservation of mass is employed to relate flow to volume changes. Each relevant law or principle is covered by a unit in a “just-in-time” lecture³ for use in the Major Project.

The students then code the equations in a double-nested Matlab FOR loop, which steps through time in small increments to solve for the updated pressure waveforms around the CV circuit during successive heartbeats. As an example of the results, Fig. 2 shows the pressure waveform in the aorta and veins during one heartbeat obtained for a healthy CV system.

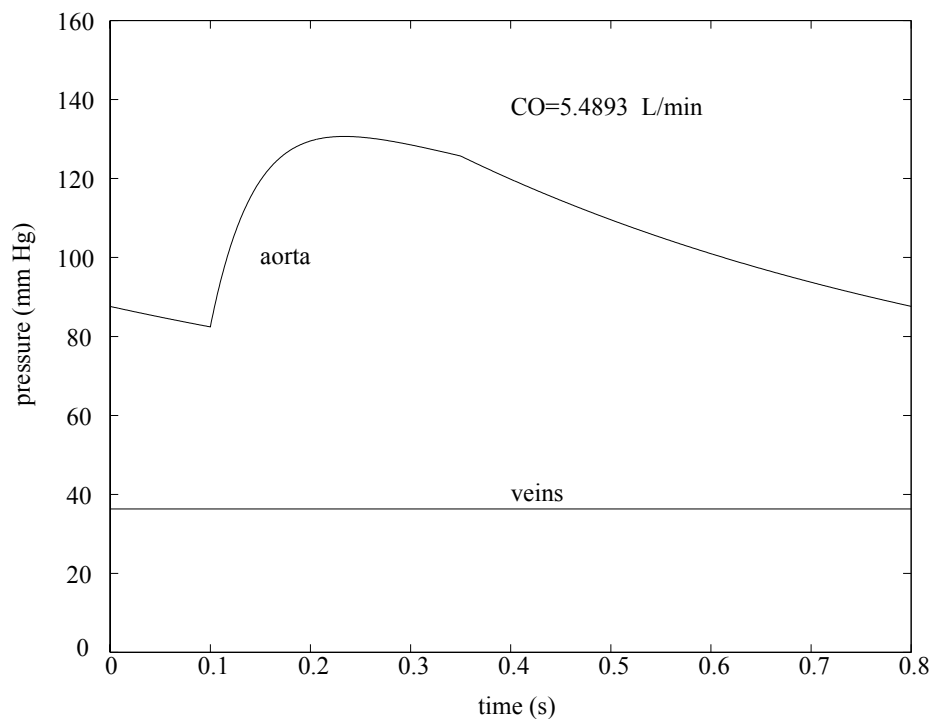

Fig. 2. Blood pressure waveforms in the aorta and veins for one heartbeat

After obtaining results for the normal CV system, each student does research to determine which values in the model should be adjusted to represent, in turn, three CV diseases: anaphylactic shock, left heart failure, and hypovolemia. The students run the modified program to note the effects on various pressures and on the cardiac output due to each disease state. Generally only one parameter value needs to be changed with each disease to clearly see the results.

Electrical Circuit Modeling – In the second portion of the Major Project, students form teams of two to assemble the electrical analog of this same CV model, after studying Ohm’s law, Kirchhoff’s laws, and Coulomb’s law as applied to resistors and capacitors. They use op amps and an analog switch to form a capacitance-multiplier module to represent the left ventricle; use resistors and capacitors to model the five segments around the CV loop; and use diodes for the two heart valves.

When the circuit is assembled and working for healthy CV parameters, the teams measure and record voltage waveforms—proportional to pressure waveforms—at various key locations in the system, and measure average current to represent the cardiac output. They then modify one circuit value to model, in turn, two more CV disease states: atherosclerosis and aortic valve regurgitation.

Some of the course’s unit topics, such as the ones dealing with leverage, Fourier analysis, and Nernst potentials, are not used directly in the Major Project, but are important topics covered in the lectures during weeks in between and after the final checkoff of the Major Project.

Student Evaluations –

Student evaluations of this course have been significantly positive. When asked about the overall effectiveness of the course on a survey form at the end of the fall 2001 semester (83 surveys completed out of 107 students enrolled), students responded with a score of 5.72 out of 6.00. Several student commented on the integrative and real-world nature of the Major Project. When asked about the benefit of the laboratory work to the goals of the course, the score was 5.71 out of 6.00. Based upon this positive feedback, we believe the lab project solidifies and makes more understandable the topics covered in the lecture; it is an example of learning by doing.

Conclusions –

It can be seen that there are two important elements in the structure of this Fundamentals class: 1) the organization of the lecture around key laws and principles, and 2) the assignment of a Major Project encompassing many of these laws and principles. It is our belief that students who successfully practice applying these fundamental principles will be better able to extrapolate bioengineering concepts later in research and industry.⁴

Bibliography –

1. C. H. Durney, “Principles of Design and Analysis of Learning Systems,” *Engineering Education*, March 1973, pp. 406-409.
2. S. C. Erickson, “Learning Theory and Educational Engineering,” *ERM*, March 1969, pp. 17-18.
3. M. E. Van Valkenburg, “Are We Ready for Top-Down Curricula?” *Engineering Education*, vol. 79, no. 4, p. 524.
4. J. D. Andrade, “Bioengineering: A Model for Engineering Education,” *BMES Bulletin*, vol. 15, no. 1, 1991, pp. 3-6.

DOUGLAS CHRISTENSEN – Dr. Christensen currently holds a joint appointment as Professor of Bioengineering and Electrical Engineering at the University of Utah. He joined the University in 1971. He obtained his PhD in Electrical Engineering at the University of Utah in 1967. His research interests include ultrasound and optical sensing for biological applications.

RICHARD RABBITT – Dr. Rabbitt is currently an Associate Professor of Bioengineering at the University of Utah. He joined the University in 1993. He obtained his PhD in Applied Mechanics from RPI in 1986. His research interests include the biophysics, biomechanics and electrophysiology of the auditory and vestibular organs.