



A TECHNICAL, ECONOMIC,
AND LEGAL ASSESSMENT OF
**North American Heavy Oil, Oil Sands,
and Oil Shale Resources**

In Response to Energy Policy Act of 2005 Section 369(p)

PREPARED FOR
U.S. DEPARTMENT OF ENERGY

PREPARED BY
**UTAH HEAVY OIL PROGRAM
INSTITUTE FOR CLEAN AND SECURE ENERGY
THE UNIVERSITY OF UTAH**

SEPTEMBER 2007

Disclaimer

This report was prepared as an account of work sponsored by an agency of the United States Government. Neither the United States Government nor any agency thereof, nor any of their employees, makes any warranty, express or implied, or assumes any legal liability or responsibility for the accuracy, completeness, or usefulness of any information, apparatus, product, or process disclosed, or represents that its use would not infringe privately owned rights. Reference herein to any specific commercial product, process, or service by trade name, trademark, manufacturer, or otherwise does not necessarily constitute or imply its endorsement, recommendation, or favoring by the United States Government or any agency thereof. The views and opinions of authors expressed herein do not necessarily state or reflect those of the United States Government.

**A Technical, Economic, and Legal Assessment of North
American Heavy Oil,
Oil Sands, and Oil Shale Resources**

In Response To

Energy Policy Act of 2005 Section 369(p)

Work Performed Under DE-FC-06NT15569

Prepared for
U.S. Department of Energy

Office of Fossil Energy
and
National Energy Technology Laboratory

Prepared by
Utah Heavy Oil Program
Institute for Clean and Secure Energy
The University of Utah
155 South 1452 East, Room 380
Salt Lake City, Utah 84112

September 2007

Acknowledgments

A Technical, Economic, and Legal Assessment of North American Oil Shale, Oil Sands, and Heavy Oil Resources In Response To Energy Policy Act of 2005 Section 369(p) is a report sponsored by the U.S. Department of Energy, Office of Fossil Energy and National Energy Technology Laboratory, and prepared under Contract Number DE-FC-06NT15569 by the Utah Heavy Oil Program in the Institute for Clean and Secure Energy at the University of Utah. Dr. David Alleman of the National Energy Technology Laboratory served as the Project Director for this report.

Special recognition is due those who directly performed the work on this report. The principal authors were Dr. Richardson Allen, Dr. Milind D. Deo, Mr. Alan E. Isaacson, Robert B. Keiter, Esq., Mr. Christopher Kessler, Dr. Raymond Levey, Dr. Kyeong Seok Oh, Dr. Philip J. Smith, Dr. Jennifer P. Spinti, and Kirsten Uchitel, Esq. on behalf of the Utah Heavy Oil Program. This report benefited greatly from the input of Dr. Murray R. Gray, Constance K. Lundberg, Esq., Dr. Olayinka Ogunsola, Dr. David K. Olsen, and Mr. Bruce Ramzel.

Forward

The Energy Policy Act of 2005 (EPAcT) section 369 paragraph (p) calls for a heavy oil technical and economic assessment as follows:

“(p) Heavy Oil Technical and Economic Assessment.--The Secretary of Energy shall update the 1987 technical and economic assessment of domestic heavy oil resources that was prepared by the Interstate Oil and Gas Compact Commission. Such an update should include all of North America and cover all unconventional oil, including heavy oil, tar sands (oil sands), and oil shale.”

The U.S. Department of Energy has tasked the Utah Heavy Oil Program (UHOP) of the Institute for Clean and Secure Energy at the University of Utah with preparation of this assessment in its Statement Of Program Objectives (SOPO) as follows:

“To develop an update of the 1987 technical and economic assessment of domestic heavy oil resources that was prepared by the Interstate Oil and Gas Compact Commission, incorporating the 1995 DOE-funded update entitled ‘Feasibility Study of Heavy Oil Recovery in the United States’ prepared by BDM-Oklahoma Inc. and other recent studies and data by others in the subject area. Such an update will include all of North America and cover all unconventional oil, including heavy oil, tar sands (oil sands), and oil shale. In addition, a publicly accessible online repository for information, data, and software pertaining to heavy oil resources in North America will be developed.”

This report has been prepared in compliance with the requirements of the UHOP SOPO as derived from EPAcT for this technical and economic assessment. Technical and economic issues are not independent of legal and environmental issues. As the legal and environmental issues impact technical and economic ones, they have been included in this report.

In the spirit of providing both historical and ongoing information, data and software to individuals and organizations seeking information on heavy oil issues, the Institute for Clean and Secure Energy has created and maintains a publicly accessible online repository at <http://www.heavyoil.utah.edu>.

Table of Contents

List of Figures.....	viii
List of Tables	x
List of Acronyms	xi
List of Units	xiv
Executive Summary.....	xv
1 Introduction.....	1.1
1.1 Energy and Global Economic Development	1.1
1.2 North American Unconventional Oil Resources	1.2
1.3 Unconventional Oil Resources and the Global Petroleum Market.....	1.4
1.4 Heavy Oil	1.4
1.5 Oil Sands	1.5
1.6 Oil Shale.....	1.5
1.7 Upstream Processing.....	1.5
1.8 Downstream Processing and Markets	1.7
1.9 Economic Issues.....	1.7
1.10 Legal and Environmental Issues	1.8
1.11 Summary	1.8
1.12 References.....	1.9
2 Utah Heavy Oil Program ArcIMS® Map Server Interface	2.1
2.1 UHOP ArcIMS® Map Server Interface	2.1
2.2 Toolbar Description.....	2.2
2.3 ArcIMS® Table of Contents.....	2.3
2.4 Usage Tips	2.4
2.5 Accessing the UHOP Repository through the Map Server Interface.....	2.4
2.5.1 Using the Identify Results Tool.....	2.5
2.5.2 Using the Select by Rectangle Tool	2.6
2.5.3 Using the Query UHOP Repository Tool.....	2.7
2.6 Future Work	2.8
3 The North American Unconventional Oil Resource	3.1
3.1 Heavy Oil Resource	3.3
3.1.1 Canadian Heavy Oil Resource.....	3.5
3.1.2 U.S. Heavy Oil Resource.....	3.6
3.1.3 Mexican and Central American Heavy Oil Resource	3.8
3.2 Oil Sands Resource	3.12
3.2.1 Canadian Oil Sands Resource.....	3.14
3.2.2 U.S. Oil Sands Resource.....	3.14
3.2.3 Mexican and Central American Oil Sands Resource	3.17
3.3 Oil Shale Resource.....	3.17
3.3.1 Canadian Oil Shale Resource.....	3.20
3.3.2 U.S. Oil Shale Resource.....	3.20
3.3.3 Mexican and Central American Oil Shale Resource.....	3.21
3.4 New Technology Impacts.....	3.21
3.5 References.....	3.21
4 Production/Processing Technologies for Unconventional Oil Resources	4.1
4.1 Production Processes for Heavy Oil	4.2
4.1.1 Evolution of Steam Injection Technologies	4.3
4.1.2 Reservoir and Performance Monitoring	4.5
4.1.3 Screening Criteria for Steamflood Technologies.....	4.5
4.1.4 Models for Steamflood Performance.....	4.6
4.1.5 New Technology Impacts and Future Research.....	4.6
4.1.6 Selected Field Surveys.....	4.8

4.1.6.1	PRU Fee in the Midway-Sunset Field.....	4.8
4.1.6.2	Kern River Field.....	4.9
4.1.6.3	Coalinga Field.....	4.10
4.1.7	In Situ Combustion.....	4.10
4.2	Production Processes for Oil Sands	4.11
4.2.1	Oil Characteristics.....	4.11
4.2.2	Surface Mining and Processing.....	4.13
4.2.2.1	Surface Mining.....	4.14
4.2.2.2	Hot Water Extraction Process.....	4.14
4.2.2.3	Water Process for Utah Oil Sands.....	4.16
4.2.2.4	Solvent Extraction Processes.....	4.17
4.2.2.5	Thermal Cracking.....	4.17
4.2.3	In Situ Processes	4.19
4.2.3.1	Cyclic Steam Stimulation and Related Methods	4.19
4.2.3.2	Steam Assisted Gravity Drainage.....	4.20
4.2.3.3	Vapor Extraction (VAPEX).....	4.21
4.2.3.4	Steamflooding.....	4.21
4.2.3.5	In Situ Combustion	4.22
4.3	Production Processes for Oil Shale	4.23
4.3.1	Chemical Nature of Oil Shale.....	4.24
4.3.2	Surface Mining and Retorting	4.26
4.3.2.1	Indirect Retorting	4.28
4.3.2.2	Direct Retorting.....	4.29
4.3.2.3	Alberta Taciuk Processor.....	4.29
4.3.3	In Situ Retorting	4.31
4.3.3.1	In Situ Conversion Process.....	4.31
4.3.4	Ongoing Commercialization Efforts.....	4.33
4.3.4.1	Surface Mining and Extraction Processes.....	4.33
4.3.4.2	In Situ Processes.....	4.33
4.4	References.....	4.34
5	Upgrading and Refining.....	5.1
5.1	Unconventional Fuels Market.....	5.1
5.2	Canadian Upgrading and Refining Strategies	5.2
5.3	Upgrading of U.S. Unconventional Fuels.....	5.4
5.3.1	Oil Sands Bitumen.....	5.6
5.3.2	Shale Oil	5.7
5.4	Primary Upgrading Technologies	5.8
5.4.1	Visbreaking.....	5.8
5.4.2	Delayed Coking	5.8
5.4.3	Fluid Coking and Flexicoking	5.8
5.4.4	Fluid Catalytic Cracking.....	5.9
5.4.5	Hydroconversion	5.10
5.5	Secondary Upgrading Technologies.....	5.10
5.5.1	Hydrocracking.....	5.10
5.5.2	Hydrotreatment for Bitumen-Derived Liquids	5.10
5.5.3	Hydrotreatment for Shale Oil.....	5.12
5.6	Enhanced Upgrading.....	5.13
5.6.1	Solvent Deasphalting and Supercritical Extraction.....	5.13
5.6.2	Gasification	5.14
5.6.3	Novel Hydrovisbreaking and Fast Pyrolysis.....	5.15
5.7	Summary	5.15
5.8	References.....	5.16

6 Economic and Social Issues Related to Unconventional Oil Production	6.1
6.1 Operating Economics	6.2
6.1.1 Heavy Oil.....	6.3
6.1.2 Oil Sands.....	6.7
6.1.3 Oil Shale	6.9
6.2 Infrastructure.....	6.11
6.2.1 Refining Capacity.....	6.11
6.2.2 Transportation.....	6.13
6.3 Socioeconomics	6.17
6.3.1 Heavy Oil.....	6.18
6.3.2 Oil Sands.....	6.25
6.3.3 Oil Shale	6.28
6.4 New Technology Impacts.....	6.31
6.5 Refinery Capacity Data by State.....	6.33
6.6 References.....	6.38
7 Environmental, Legal and Policy Issues Related to Unconventional Fuel Resource Development on the Public Lands	7.1
7.1 General Legal and Policy Framework for Unconventional Fuel Resource Development	7.3
7.1.1 Mineral Leasing Act of 1920, as Amended by the Combined Hydrocarbon Leasing Act of 1981 and the Energy Policy Act of 2005	7.3
7.1.2 Energy Policy Act of 2005	7.5
7.1.2.1 Programmatic Environmental Impact Statement for Oil Shale and Oil Sands Leasing in Colorado, Wyoming and Utah	7.6
7.1.2.2 Research, Development and Demonstration Leases for Oil Shale Technologies..	7.6
7.1.2.3 Regulatory Framework for Oil Sands and Oil Shale	7.7
7.1.3 Summary.....	7.8
7.2 Existing Environmental Analysis and Land Use Planning Obligations under the National Environmental Policy Act and the Federal Land Policy and Management Act for Commercial Leasing and Development of Unconventional Fuel Resources	7.10
7.2.1 National Environmental Policy Act	7.10
7.2.2 Federal Land Policy and Management Act.....	7.13
7.2.3 Summary.....	7.16
7.3 Legal and Policy Framework for Air Quality Issues and Impacts Related to Unconventional Fuel Resource Development	7.17
7.3.1 Clean Air Act	7.18
7.3.2 Comprehensive Environmental Response, Compensation and Liability Act	7.20
7.3.3 Greenhouse Gas Emissions.....	7.20
7.4 Legal and Policy Framework for Flora and Fauna Issues and Impacts Related to Unconventional Fuel Resource Development	7.21
7.4.1 Endangered Species Act.....	7.21
7.4.2 Migratory Bird Treaty Act; Bald Eagle Protection Act.....	7.23
7.5 Legal and Policy Framework for Land Management Issues and Impacts Related to Unconventional Fuel Resource Development	7.23
7.6 Legal and Policy Framework for Water Issues and Impacts Related to Unconventional Fuel Resource Development	7.24
7.6.1 Clean Water Act	7.25
7.6.2 Safe Water Drinking Act.....	7.25
7.6.3 Colorado River Basin Salinity Control Act	7.25
7.6.4 Law of the River	7.26
7.6.5 Endangered Species Act.....	7.27
7.7 Reclamation.....	7.28
7.8 References.....	7.29

List of Figures

Figure 1-1.	World marketed energy consumption by region	1.1
Figure 1-2.	Total world primary energy consumption (% by fuel)	1.1
Figure 1-3.	Historical and projected domestic energy consumption by fuel in quadrillion BTUs	1.2
Figure 1-4.	Size of world conventional oil reserves compared to U.S. oil shale and Canadian oil (tar) sands reserves.....	1.3
Figure 1-5.	Costs of oil dependence to the U.S. economy from 1970-2006 assuming a constant competitive world oil price of \$13 per barrel.....	1.4
Figure 2-1.	Some of the frames available in the UHOP map server interface	2.1
Figure 2-2.	Table of contents for map server interface	2.3
Figure 2-3.	Accessing the UHOP repository through posted tabular results.....	2.5
Figure 2-4.	Tabular results using the Identify Results tool.....	2.6
Figure 2-5.	Tabular results using the Select by Rectangle tool.....	2.7
Figure 2-6.	Results from a UHOP Dspace repository query	2.8
Figure 3-1.	Chart of heavy oil, extra heavy oil, and bitumen based on viscosity vs. density.....	3.1
Figure 3-2.	Main distribution of heavy oil to bitumen, and variation during degradation..	3.2
Figure 3-3.	Map from the UHOP map server interface showing the location of heavy oil deposits in North America	3.3
Figure 3-4.	Age of heavy oil deposits in the United States and Canada	3.4
Figure 3-5.	Location of the Grosmont Platform in Alberta and its relationship to the Athabasca Oil Sands and the Lloydminster heavy oil deposits.....	3.6
Figure 3-6.	Location of the southwestern California heavy oil basins.....	3.7
Figure 3-7.	Distribution of heavy oil overlying the Kuparuk River, Milne Point, and Prudhoe Bay fields on the North Slope of Alaska.....	3.8
Figure 3-8.	Map of the exploration and production regions (Región) of Mexico.....	3.10
Figure 3-9.	Map of the areas (Activo Integral) in the Marina Noreste region in Mexico	3.10
Figure 3-10.	Map of the areas (Activo Integral) in the Norte region in Mexico.....	3.11
Figure 3-11.	Map from the UHOP map server interface showing the location of oil sands in the North America.....	3.12
Figure 3-12.	Age of oil sands deposits in the United States and Canada.....	3.13
Figure 3-13.	Location of oil sands in Utah	3.16
Figure 3-14.	Map from the UHOP map server interface showing the location of oil shale deposits in North America.....	3.17
Figure 3-15.	Age of oil shale deposits in the United States and Canada	3.18
Figure 3-16.	Location of the Green River Formation in Wyoming, Utah and Colorado	3.20
Figure 4-1.	California heavy oil production and steam injection to produce the heavy oil during the period 1991-2005.....	4.3
Figure 4-2.	Breakdown of steamflood/steamdrive processes in California over a 40-year period.....	4.4
Figure 4-3.	Heat management in a steamflood process	4.5
Figure 4-4.	Evolution of steamflood theory from a pressure displacement process to a gravity drainage process	4.6
Figure 4-5.	Schematic diagram of a water-based bitumen recovery process	4.15
Figure 4-6.	Bitumen liberation and aeration in water-based extraction process	4.16
Figure 4-7.	Schematic of a cyclic steam stimulation process showing injection, soak and production	4.20
Figure 4-8.	Illustration of the SAGD process including the horizontal injector, the horizontal producer, and some surface facilities.....	4.21

Figure 4-9.	Schematic of the THAI Process.....	4.22
Figure 4-10.	Generalized processes for conversion of shale to fuels and byproducts	4.23
Figure 4-11.	TOSCO II process	4.28
Figure 4-12.	Gas combustion retorting process.....	4.29
Figure 4-13.	Alberta Taciuk Process system.....	4.30
Figure 4-14.	Shell In situ Conversion Process	4.32
Figure 5-1.	Combination of technologies to reduce dependence of upgrading on natural gas	5.3
Figure 5-2.	Schematic of a fluid coker	5.9
Figure 5-3.	Conceptual simulated distillation curves for the extract, bitumen and the residue after supercritical extraction	5.13
Figure 6-1.	Real price of imported, low-sulfur crude oil with forecasts to 2030	6.1
Figure 6-2.	Price of WTI and less than 20° API gravity crude	6.4
Figure 6-3.	Internal rates of return for a single inverted nine-spot well pattern	6.6
Figure 6-4.	Petroleum Administration for Defense Districts	6.12
Figure 6-5.	PADD IV refinery utilization rates	6.13
Figure 6-6.	Crude oil pipelines and refineries, with capacities in barrels per day, in the Rocky Mountains and the Midwest.....	6.15
Figure 6-7.	Kern County, California.....	6.19
Figure 6-8.	Southern California area.....	6.20
Figure 6-9.	Utah counties directly impacted by future oil sands development.....	6.25
Figure 6-10.	Counties directly impacted by future oil shale development	6.28
Figure 7-1.	The White River oil shale mine located south of Bonanza, Uintah County, Utah	7.2
Figure 7-2.	Oil shale and oil sands deposits in Utah, including STSA and sensitive lands designations.....	7.4
Figure 7-3.	Utah oil sands with seeping bitumen	7.9
Figure 7-4.	Oil shale from the Green River Formation	7.9
Figure 7-5.	Green River Formation oil shale outcropping.....	7.17
Figure 7-6.	The Colorado River Basin.....	7.27

List of Tables

Table 2-1.	Tools and buttons available for use with the UHOP map server.....	2.2
Table 3-1.	U.S. Heavy Oil Database (10°-20° API gravity).....	3.5
Table 3-2.	Table of the remaining proven, probable and possible hydrocarbon reserves in Mexico as of January 1, 2006.....	3.9
Table 3-3.	Original in-place crude oil and oil sands and remaining proven reserves for Alberta	3.14
Table 3-4.	Oil sands resource in the Athabasca, Peace River and Cold Lake deposits.....	3.14
Table 3-5.	Oil sands resource in the United States	3.15
Table 3-6.	Table of the Utah oil sands resource in-place.....	3.15
Table 3-7.	Characterization of North American oil shale deposits	3.19
Table 4-1.	Typical physical and chemical properties of Utah oil sands bitumen	4.12
Table 4-2.	Typical physical and chemical properties of Canadian Athabasca and Cold Lake bitumens.....	4.13
Table 4-3.	Bitumen viscosity comparison of Utah and Canadian Athabasca oil sands.....	4.13
Table 4-4.	Properties of bitumen-derived products obtained by thermal fluidized-bed pyrolysis of oil sands	4.18
Table 4-5.	Material balance and Fisher Assay results for reference shales.....	4.25
Table 4-6.	Average chemical and elemental compositions of several oil shale samples from Rifle, Colorado in the Green River Formation.....	4.26
Table 5-1.	Available upgrading processes	5.5
Table 5-2.	Operating temperatures and pressures of upgrading technologies	5.6
Table 5-3.	Comparison of yield and conversion results for upgrading of Asphalt Ridge bitumen.....	5.7
Table 5-4.	Properties of shale oil (raw and upgraded) and of a light Arab crude	5.7
Table 5-5.	Properties of bitumen and bitumen-derived liquids from the Whiterocks, Utah oil sands deposit.....	5.12
Table 5-6.	Extraction yields and properties from the supercritical propane extraction of four Utah bitumens	5.14
Table 6-1.	Costs applicable to steam injection, 1990-2004	6.5
Table 6-2.	Steam injection economic parameters considered for internal rate of return calculations.....	6.7
Table 6-3.	Production costs of Canadian oil sands, 2005 dollars per barrel	6.8
Table 6-4.	Refinery capacity by PADD district and process.....	6.12
Table 6-5.	Petroleum flows by pipeline (thousand barrels) between the Rocky Mountains and adjacent areas, 2005	6.14
Table 6-6.	Estimated construction costs of proposed pipeline projects, 2006	6.16
Table 6-7.	Annual average wages in the affected states by industry, 2005	6.18
Table 6-8.	Socioeconomic profiles of examined heavy oil areas.....	6.20
Table 6-9.	Oil industry employment and wages in the heavy oil areas, 2005	6.21
Table 6-10.	Employment by industry in Kern County, California, 2005.....	6.21
Table 6-11.	Employment by industry of North Slope Borough, Alaska, 2005.....	6.22
Table 6-12.	Employment by industry of the three southern California counties, 2005.....	6.23
Table 6-13.	Recent oil and gas production in heavy oil areas.....	6.24
Table 6-14.	Socioeconomics of the oil sands area	6.26
Table 6-15.	Employment by industry in the oil sands area, 2005	6.26
Table 6-16.	Recent oil and gas production in the oil sands area.....	6.27
Table 6-17.	Socioeconomics of the oil shale area	6.29
Table 6-18.	Employment by industry in the oil shale area, 2005.....	6.29
Table 6-19.	Recent oil and gas production in the oil shale area	6.30
Table 6-20.	Petroleum refineries in states most likely to produce heavy oil, oil sands and oil shale.....	6.33

List of Acronyms

ACEC	Areas of Critical Environmental Concern
ARC	Alberta Research Council
API	American Petroleum Institute
ATP	Alberta Taciuk Processor
BACT	Best Available Control Technology
BEPA	Bald Eagle Protection Act
BLM	Bureau of Land Management
BOPD	Barrels of Oil per Day
C	Carbon
C1	Methane
C4	Butane
C5	Pentane
C\$	Canadian Dollars
CAA	Clean Air Act
CAPP	Canadian Association of Petroleum Producers
CCR	Conradson Carbon Residue
CEQ	Council on Environmental Quality
CERCLA	The Comprehensive Environmental Response, Compensation, and Liability Act
CFR	Code of Federal Regulations
CHLA	Combined Hydrocarbon Leasing Act
CO ₂	Carbon Dioxide
CRBSCA	Colorado River Basin Salinity Control Act
CSS	Cyclic Steam Stimulation
CWA	Clean Water Act
DOE	Department of Energy
DOI	Department of Interior
DTS	Distributed Temperature Sensing
EA	Environmental Assessment
EIS	Environmental Impact Statement
EOR	Enhanced Oil Recovery
EPA	Environmental Protection Agency
EPAct	Energy Policy Act of 2005
ES-SAGD	Expanding Solvent Steam-Assisted Gravity Drainage
ESA	Endangered Species Act
FCC	Fluid Catalytic Cracking
FERC	Federal Energy Regulatory Commission
FLPMA	Federal Land Policy and Management Act
FONSI	Finding of No Significant Impact
FWS	Fish and Wildlife Service
GCRA	Global Change Research Act
GIS	Geographic Information System
GML	General Mining Law
GDP	Gross Domestic Product
H	Hydrogen
H ₂	Hydrogen Gas
H/C	Hydrogen to Carbon Ratio
HUTF	Hydrocarbon Upgrading Task Force
IBP	Initial Boiling Point

ICP	In situ Conversion Process
IOGCC	Interstate Oil and Gas Compact Commission
IOR	Improved Oil Recovery
IRR	Internal Rate of Return
LAER	Lowest Achievable Emissions Reduction
LASER	Liquid Addition to Steam for Enhancing Recovery
LNG	Liquified Natural Gas
LPG	Liquified Petroleum Gas
MACT	Maximum Available Control Technology
MBTA	Migratory Bird Treaty Act
MLA	Mineral Leasing Act
MMBO	Million Barrels of Oil
MW	Molecular Weight
N	Nitrogen
NAAQS	National Ambient Air Quality Standards
NAICS	North American Industry Classification System
NaOH	Sodium Hydroxide
NCUT	National Centre for Upgrading Technology
NEPA	National Environmental Policy Act
NESHAPS	National Emission Standards for Hazardous Air Pollutants
Ni	Nickel
NMFS	National Marine Fisheries Service
NPS	National Park Service
O	Oxygen
OECD	Organisation for Economic Co-operation and Development
OIP	Oil in Place
OOIP	Original Oil In Place
OPEC	Organization of the Petroleum Exporting Countries PADD Petroleum Administration for Defense Districts
PEIS	Programmatic Environmental Impact Statement
PET	Production Enhancement Tools
PNC	Pulsed Neutron Capture
PSD	Prevention of Significant Deterioration
RACT	Reasonably Available Control Technology
RCRA	Resource Conservation and Recovery Act
RD&D	Research, Development and Demonstration
RMP	Resource Management Plan
S	Sulfur
SAGD	Steam-Assisted Gravity Drainage
SARA	Saturates, Aromatics, Resins and Asphaltenes
SCO	Synthetic Crude Oil
SG	Specific Gravity
SI	International System of Units
SIP	State Implementation Plan
SO ₂	Sulfur Dioxide
SOR	Steam to Oil Ratio
STSA	Special Tar Sand Area
SWDA	Safe Water Drinking Act

TESS	Threatened and Endangered Species System
THAI	Toe-to-Heel-Air-Injection
TMDL	Total Maximum Daily Load
UHOP	Utah Heavy Oil Program
UNITAR	United Nations Institute for Training and Research
USFS	United States Forest Service
USGS	United States Geological Survey
V	Vanadium
VAPEX	Vapor Extraction
WOR	Water to Oil Ratio
WPC	World Petroleum Congress
WQS	Water Quality Standard
WSA	Wilderness Study Area
WSR	Wild and Scenic River
WTI	West Texas Intermediate

List of Units

BTU	British Thermal Unit
BTU/lb	British Thermal Units per pound
cP	Centipoise
D	Darcies
g/cc	Grams per cubic centimeter
GW	Gigawatt
KW	Kilowatt
KW-hr	Kilowatt hour
m ³ /s	Cubic meters per second
MCF	Thousand cubic feet
mD	Millidarcies
MJ/kg	Megajoules per kilogram
MMBTU	Million British Thermal Units
MPa	Megapascals
Pa•s	Pascal seconds
ppm	Parts per million
psia	Pounds per square inch absolute
wt%	Weight percent

Executive Summary

Against the backdrop of world population growth, rapid economic expansion in the world's most populous countries, challenging political climates in many oil-producing nations, and the specter of climate change, worldwide energy consumption is projected to increase from the 2004 level of just over 400 quadrillion British Thermal Units (BTUs) to over 700 quadrillion BTUs in 2030 [1]. With 35% of the world's energy needs being met by petroleum in 2003 [2], petroleum is expected to remain a dominant player in worldwide energy markets for the foreseeable future. Consequently, world economic development will continue to be significantly impacted by the cost of oil.

In the United States, energy policy is again focused on evaluating domestic energy resources and their potential to achieve greater energy independence and reduce future energy crises. Unconventional hydrocarbon resources, including heavy oil, oil sands, and oil shale, represent a significant North American resource. Estimates of proven conventional oil reserves worldwide are 1.0 trillion barrels with an additional 1.7 trillion barrels of possible/undiscovered reserves [3]. Canadian oil sands reserves are estimated at 1.7 trillion barrels with 174 billion barrels recoverable using proven current technologies [4]. A conservative estimate of worldwide in-place oil shale reserves is 2.9 trillion barrels, with 2.0 trillion barrels of this resource located in the United States [5]. The Rand report puts the range of oil recovery from shale at 0.5-1.1 trillion barrels depending on the percent accessible and recoverable [6].

The purpose of this report is to assess unconventional North American resources, summarize current technologies for extracting and processing the resources, identify the issues which will affect the economic viability of various resource development schemes, evaluate the socioeconomic costs to communities and states impacted by such development, and analyze the regulatory and environmental climate in which the resource development will operate.

In addition to this written report, the Utah Heavy Oil Program (UHOP) of the Institute for Clean and Secure Energy at the University of Utah has been commissioned to build a repository to hold information relevant to the resources of heavy oil, oil shale and oil sands in North America. UHOP has developed a map server interface to deliver dynamic maps and to explore the UHOP repository in a geospatial setting. All that is required for users to interface with the UHOP map server is a fast internet connection and a compatible web browser. The current URL for the UHOP map server is http://map.heavyoil.utah.edu/website/uhop_ims.

Origin of unconventional fuel resources. The unconventional fuels assessed in this report are classified as heavy oil/extra heavy oil, bitumen from oil sands, and oil shale. To form conventional and unconventional fuels, organic material was buried in fine grained sediments in an oxygen poor environment. This buried material was first converted to kerogen, an immature form of organic material and a precursor to oil, at shallow depths and at temperatures below 122°F (50°C). Kerogen was further converted to oil at depths of 1.2-2.4 miles (2-4 kilometers) and temperatures of 122°-212°F (50°-100°C) [8]. Heavy and extra heavy crude oil are biodegraded forms of oil that occur when lighter oil fractions are lost or are consumed by bacteria in the reservoir, leaving the heavier molecules behind [9]. Oil sands are an extremely heavy form of crude oil [10]. Oil sand is defined as any consolidated or unconsolidated rock,

An unconventional fuel cannot be recovered in its natural state from an ordinary production well, i.e. it cannot be pumped without being heated or diluted [7].

exclusive of coal or oil shale, that contains a hydrocarbon material known as bitumen. Oil sands are generally comprised of crude bitumen, sand, water, and clay. Oil shale is defined as a fine-grained sedimentary rock bound with kerogen where the organic and the inorganic matter are inextricably combined.

Classification of unconventional fuel resources. Heavy oil, extra heavy oil, and bitumen from oil sands, all organic liquids, are classified by their American Petroleum Institute (API) gravity and viscosity. The API gravity scale, graduated in degrees, was designed so that most hydrocarbon liquids would be in the range from 10°-70°. Light crude oil has an API gravity that exceeds 31.1° [7]. Heavy oil has an API gravity of 10°-22.3° and viscosity of 100-10,000 cP at 60°F (15.6°C); extra heavy oil has an API gravity below 10° and viscosity of 100-10,000 cP at 60°F (15.6°C); and bitumen has viscosity above 10,000 cP at 60°F (15.6°C) [11]. Bitumen viscosity is so high that it does not flow and cannot be pumped without being heated, diluted, or upgraded. Oil shale, a fine-grained sedimentary rock rich in kerogen, has a distinct classification from heavy oil and bitumen. All known processes for disengaging the kerogen from the inorganic matrix and converting it to oil require heat input. Heating the source rock yields oil, natural gas, and/or graphite [12,13].

Heavy oil resource. North American heavy oil/extra heavy oil deposits are located in Canada, the United States, and Mexico. The three largest North American deposits are the Lloydminster deposits in western Canada containing 101.7 billion barrels original oil in place (OOIP) [14], a series of deposits in California with 75.8 billion barrels OOIP, and the deposits in the Schrader Bluff/West Sak/Ugnu area on the North Slope of Alaska with 25 - 30 billion barrels OOIP [15,16]. In the U.S. Heavy Oil Database [17], which is exclusive of Alaska, total OOIP constitutes 84.2 billion barrels. Cumulative production has reached 10.8 billion barrels, leaving the remaining oil in place at 73.4 billion barrels. Estimates of Mexican heavy oil reserves are 18.8 billion barrels remaining oil in place, which accounts for about 57% of the total remaining proved, probable and possible oil in place in Mexico [18].

Oil sands resource. North American oil sands deposits are located in Canada and the United States. Canada has one of the greatest oil reserves in the world in the form of oil sands, with almost 1.7 trillion barrels of OOIP in the form of bitumen in western Canada [4]. The U.S. oil sands resource is estimated at 54 billion barrels OOIP in the form of bitumen; 22 billion barrels are considered to be a measured resource with 32 billion barrels considered speculative [19]. The largest oil sands deposits in the United States are in the state of Utah with proven reserves of 8-12 billion OOIP in the form of bitumen and total reserves (including speculative reserves) of 23-32 billion barrels OOIP [19-21].

Oil shale resource. North American oil shale resources occur in Canada and the United States. The Green River Formation in Colorado, Utah, and Wyoming is, volumetrically, the largest oil shale resource in the United States with resource estimates of 1.5-1.8 trillion barrels OOIP in shale deposits exceeding a grade of 15 gallons of oil per ton of shale [22]. Devonian-Lower Mississippian shales in the eastern United States show lower total organic content than the Green River Formation but may contain 189 billion barrels OOIP in the form of kerogen [5]. Canadian oil shale reserves have been identified, but many lack estimates on the size of the resource [5,23].

API Gravity = $(141.5 / \text{specific gravity at } 60^\circ\text{F}) - 131.5$. Water has an API gravity of 10°. A liquid with API greater than 10° floats on water while a liquid with API less than 10° sinks in water.

Centipoise (cP) is one hundredth of a poise, a unit of viscosity in the centimeter-gram-second unit system.

OOIP refers to oil in place prior to any production.

The terms oil sands and tar sands are synonymous.

Current unconventional fuel production. In the United States, the only unconventional fuel currently being produced on a commercial scale is heavy oil. Most heavy oil production is in the state of California, where production levels have declined continuously in the past decade from a high of 660,000 BOPD in 1996 to 470,000 BOPD in 2005 [24]. Continued high oil prices have spurred additional investment and drilling in California, the effect of which might be a slower decline in production in 2007. However, unless other large fields come on line, it is unlikely that the observed decline will be arrested. There are also large heavy oil resources in Alaska, but Alaskan production of heavy oil is low relative to total heavy oil production in the United States. In 2003, combined Alaskan heavy oil production from two units was 26,800 BOPD [25]. Heavy oil production also occurs on a commercial scale in Canada and Mexico, however, both countries use definitions of heavy oil that vary from that used in this report. Pemex, the Mexican state oil company, reported production of 2.4 million BOPD of heavy crude oil during 2005. In 2006, reported production dropped 6% from 2005 levels [26]. Similarly, the Canadian Association of Petroleum Producers (CAPP) reported that Canada produced 526,000 BOPD of heavy oil in 2005, down from 497,000 BOPD of heavy oil in 2004 [27].

BOPD refers to barrels of oil per day.

Pemex defines heavy oil as that with an API gravity of less than 27°.

CAPP defines heavy oil as that with an API gravity of less than 28°.

North American oil sands production experience is concentrated in Alberta, Canada, where current production levels are 1.2 million BOPD in the form of bitumen [28]. Based on anticipated growth, production could increase to 3 million BOPD by 2020 [29]. Oil sands production in the United States is limited to two pilot-scale operations in Utah [30,31]. Oil shale is not produced on a commercial scale anywhere in North America. Despite the technical progress that has been made in oil shale processing since the last oil shale boom in the 1970s, oil shale commercialization faces major obstacles. Those obstacles include the high initial capital investment, the possible instability of world crude oil prices, the lack of a clearly defined federal oil shale development policy, and environmental considerations [6,12,13].

Heavy oil production processes. The production processes for these unconventional fuels are classified according to whether the oil-bearing material is processed on the surface (surface extraction and processing) or the oil is produced “in-place” (in situ). In the United States, heavy oil is produced in situ due to the depth of most deposits, primarily using steam injection technologies (steamflood/steamdrive). These technologies involve the continuous injection of steam to displace oil toward production wells. The NIPER/BDM report estimated that about 8 billion of the 68 billion barrels of California heavy oil could be recovered using steam injection technologies [32]. Profitability of a steam injection operation depends on the steam to oil ratio (SOR), the energy source used to generate the steam and the cost of that source. Natural gas is the predominant energy source in California steamfloods. Current high natural gas prices may be influencing the heavy oil production decline in California.

In a steamflood/steamdrive process, steam is injected into the heavy oil reservoir through injection wells and oil, steam, gases and water are produced from a second set of wells, the production wells.

Steam to oil ratio (SOR) is the amount of water equivalent barrels injected per barrel of oil produced. Process efficiency improvements will decrease this number.

Oil sands production processes. Oil sands in Alberta, Canada, are produced via surface extraction/processing or in situ, depending on the depth of the deposit. Currently, surface extraction/processing accounts for 60% and in situ processes account for 40% of the total production of 1.2 million BOPD in the form of bitumen [28]. In the Athabasca region in Alberta, mining has provided access to vast quantities of uniformly rich, unconsolidated oil sands deposits with little or no overburden. Commercial development of mining and extraction processes has been achieved through efficiencies of scale (i.e. very large mining and processing operations) and extensive research over the

past 30 years [33]. Surface extraction processes are solvent-based, with water being the most common solvent; other (mainly hydrocarbon) solvents have been reported, but are not yet commercial [34]. In situ technologies for oil sands production are modifications of steam injection technologies for heavy oil reservoirs, of which the best known is steam-assisted gravity drainage (SAGD) [35]. The contribution to Canadian oil production from in situ technologies is expected to grow and dominate the targeted 3 million BOPD of production in the next ten to fifteen years.

Mining Utah oil sands will be more challenging than mining Canadian oil sands because the Utah deposits, while relatively shallow, are lenticular, are located in more rugged and mountainous terrain, and are geologically condensed. The consolidated deposits will require milling-type mining equipment in contrast with the shovel-type equipment used in Canada. Nevertheless, Utah oil sands have two significant advantages over Canadian oil sands. One, the quantity of fines is lower and two, the percentage of sulfur in the bitumen is much lower.

Differences between Canadian and Utah oil sands require the optimization of the Canadian hot water extraction process for Utah oil sands. In general, Utah oil sands have lower porosity, lower bitumen content, lower water content, higher consolidation, higher viscosity bitumen and fewer clay minerals than their Canadian counterpart. Optimal conditions for hot-water extraction have been determined from research specific to Utah oil sands [36]. Presently, pilot-scale and small commercial-scale activities involving mining and solvent extraction are being conducted by Temple Mountain Energy and Earth Energy Resources Inc. in some Utah deposits. While the solvents used in these processes have not been publicly disclosed, both companies claim very high bitumen recovery (99%+) and good solvent recovery. Based on what has been publicly stated, if the mining costs can be controlled, these processes should be economical [30,31]. If commercial development of Utah oil sands were to occur in the short term, it appears that solvent extraction would be the process of choice.

As substantial portions of the Utah deposits are deep and not easily accessible, in situ processing should also be considered. The stratified and lean nature of the Utah deposits implies that in situ processing will require considerably more energy than a comparable process in Canada as energy will be wasted in heating non-oil-bearing layers. One advantage of in situ methods in the arid western United States is reduced water consumption over surface extraction methods [37,38].

Oil shale production processes. Production processes for the thermal treatment of oil shale deposits fall into the same categories as oil sands production processes. With surface (ex situ) mining and processing, oil shale is mined, crushed, and then subjected to thermal processing at the surface in an oil shale retort. With in situ production, the shale is left in place and the retorting (e.g. heating) of the shale occurs in the ground. Higher efficiencies can be obtained with surface mining and processing, but the overburden is so thick and the deposits so large in the western United States that the mines would be comparable to the largest open-pit mines in the world [6,22].

Oil shale can be produced through traditional mining methods, followed by crushing and retorting of the ore. During retorting, kerogen decomposes into three organic fractions: oil, gas and residual carbon. Oil shale decomposition begins at relatively low retort temperatures (572°F/300°C) but proceeds more rapidly and more completely at

In lenticular deposits, the rich deposits are often interspersed with lean sands or shales.

higher temperatures with the highest decomposition rates occurring at retort temperatures of 896°-968°F (480°-520°C) [39]. Most conventional retorts are operated in or near this temperature range. The shale oil produced from the retort is partially upgraded and is an appropriate feedstock for the existing U.S. oil refining infrastructure, comparable to a light, sweet crude oil. Spent shale disposal and the environmental degradation that comes with mining the ore are two principal environmental concerns with oil shale development. A high yield deposit of oil shale will yield 25 gallons (0.60 barrels) of oil per ton (0.91 metric tons) of material. About 8 million tons (7.3 metric tons) of ore would need to be mined daily to meet one-quarter of the U.S. demand of 20 million BOPD, resulting in massive quantities of spent shale that would need to be reclaimed [6,22]. Nevertheless, the Canadian oil sands operations have demonstrated that the efficiency of mining operations improves at larger scales. Additionally, significant advances have been made in the fields of process design and control, simulation/modeling, separation and purification, and environmental impact reduction. Pilot plants would need to be built to test the viability of this production method.

A metric ton is 1000 kilograms.

In the early 1980s, Shell proposed a new method of in situ retorting, the In situ Conversion Process (ICP). ICP is comprised of a series of underground heaters drilled into an oil shale deposit on a one square mile (2.6 square kilometer) grid. Approximately 15 to 25 holes are drilled per acre in a variety of configurations, and electrical resistance heaters are inserted into the holes. The target depth zone for the wells is 1000-2000 feet (305-610 meters), depending on deposit location. The shale deposit is heated to temperatures of 650°-700°F (343°-371°C), which are much lower than surface retort temperatures, for 2-3 years in order to release the oil from the shale [40]. The oil and any associated gas are then pumped out of the ground using conventional methods [6]. The oil is of a very high quality and quite different from traditional crude oils in that it contains light hydrocarbons and almost no heavy ends. However, the energy costs of heating the oil shale are significant. With electrical heating, 2 units of energy are gained from the oil shale for every unit of energy consumed assuming the electricity is produced by a standard coal-fired power plant. If the power plant is a 60% efficient, combined cycle gas power plant, the energy balance is 3.5 to 1. Research on gas-fired heating, which will utilize the natural gas being recovered from the drilling process, may improve the energy balance to 5.5 to 1 [41].

Upgrading of unconventional fuel resources. Lower API crude oils such as heavy oil, oil sand bitumen, and shale oil from surface retorts produce lower quantities of conventional refinery products than light crude oils. As a result, the value of these oils is less than that of higher API crude oils. Upgrading is the process of converting these lower value oils to higher API oils more suitable for conventional refinery feedstocks. Partial upgrading reduces the heavy oil/bitumen viscosity and density, rendering it suitable for transportation to a refinery [42]. In contrast, the ICP process produces a refinery-ready shale oil that will not require partial upgrading prior to transportation to a refinery. The most common international standard for upgrading is the conversion of the vacuum residue to lower boiling point fractions.

Vacuum residue is the cut which boils above 1000°F/538°C.

Oil sands and oil shale development in the United States is most likely to occur in the Rocky Mountain region, where very limited refinery capacity exists for processing heavy oils/bitumen and refinery capacity utilization is high [43,44]. Partially or fully upgraded synthetic crude oil produced from oil sands and oil shale would need to be shipped to other regions of the country for refining. In addition, no partial upgrading

capacity exists in either Colorado's Piceance Basin or Utah's Uinta Basin, the probable epicenter for both oil sands and oil shale development. The two ten-inch pipelines serving the basins could not be utilized unless partial upgrading were available in the field; additional pipeline capacity would then be needed to handle the volume of expected product. Canada already faces this situation, with potential production expected to be constrained by existing pipeline capacity within a decade [45]. The choices for upgrading unconventional fuels in the Rocky Mountain region will depend on the quality of the oil produced, the refining market and pipelines available at the time, the energy sources (gas, coal, etc.) in the vicinity, the qualities of other crude oils being produced at the time, and how successfully current Canadian upgrading technologies can be integrated into the U.S. refinery framework.

Upgrading technologies are classified as primary, secondary or enhanced. Primary upgrading is mainly a molecular weight reduction process, while secondary upgrading involves removal of impurities from the feed. The primary upgrading processes may or may not use a catalyst, while the secondary processes are catalytic. Emerging technologies are classified as enhanced upgrading methods. The mainstay of the oil sands upgrading operations in Canada has been coking. Hydrotreating is less common but has been used in upgrading conventional heavy oil (of the type produced in California). A sharp increase in the use of natural gas as a source of hydrogen and of energy in the upgrading process has led to the exploration of residue (atmospheric and vacuum) gasification as an alternative source [46]. Since shale oil is produced by thermal means, it is partially upgraded and may only require mild hydrotreatment depending on the shale. Bitumen produced from oil sands, via surface extraction methods or in situ processes, requires more extensive upgrading.

Relevant economics of conventional petroleum market. Petroleum derived from heavy oil, oil sands and oil shale must achieve profitability in a worldwide commodity market with transparent pricing that is dominated by conventional crude oil. The future of these sources of energy is strongly linked to the future price of crude oil. In constant dollars (with 2005 purchasing power), the price of crude oil peaked in the early 1980s at over \$80 per barrel. Prices dropped precipitously in the latter half of the 1980s to \$20-\$30 per barrel, then dropped again in 1998 to \$16 per barrel. Prices have since rebounded to \$66 per barrel in 2007 [47]. Forecasts show a gradual decrease in the price of crude oil through 2015 as additional exploration and development brings new supplies to the world market [48]. After 2015, real prices (constant dollars with 2005 purchasing power) are forecast to increase due to rising worldwide demand and higher-cost supplies with the average real price of imported low-sulfur crude oil forecast to be over \$59 per barrel by 2030. In addition, worldwide demand for crude oil is projected to grow from 80 million BOPD in 2003 to 118 million BOPD in 2030 [48]. Given this forecast for high crude oil prices and growth in demand, it is highly likely that profitable operating economics will lead to additional development of heavy oil, oil sands and oil shale resources in the United States.

Heavy oil production economics. The degree to which the economics of heavy oil, oil sands, and oil shale are understood is dependent on the extent of resource commercialization. Heavy oil is produced in large quantities in southern California, Canada, and Mexico, and the economics of this industry are well understood. Heavy oil must compete with lighter grades of crude oil. The price of heavy crude from California

During the coking process, heavy oil/bitumen is thermally decomposed in an oxygen-free environment to form the solid carbonaceous product, coke.

Hydrotreating is an upgrading process used to remove nitrogen, sulfur, and heavy metals from petroleum feedstocks.

Gasification is a process in which a carbonaceous material (e.g. natural gas, liquid hydrocarbon, coal, or heavy oil residue) is reacted with steam to produce a mixture of carbon monoxide and hydrogen known as synthesis gas or syngas. This process is also called steam reforming.

Constant dollars take into account inflation so they have equal purchasing power.

trades at a discount to West Texas Intermediate (WTI) crude, and the discount has recently widened. During 2003, California 13° API heavy crude oil traded at a \$5.66 per barrel discount to WTI crude, a discount that widened to \$12.34 per barrel in 2005 [49]. This price discount is driven by the market for oil and is influenced by both worldwide demand and local factors such as pipeline and refinery capacity; it does not represent the higher capital and operating costs required for heavy oil recovery using steam injection nor the cost of the additional upgrading/refining.

West Texas Intermediate (WTI) refers to a crude stream produced in Texas and southern Oklahoma that serves as a reference or “marker” for pricing a number of other crude streams.

Heavy oil economics are largely driven by three factors: oil price, the price of energy to generate steam, and the amount of recoverable oil in place using steam injection technology. The critical parameter that determines the profitability of heavy oil production is the SOR. While engineering can aid in optimizing this ratio, geology establishes the baseline SOR and the ultimate success of a project. As natural gas is used to generate steam, production economics have also been complicated by the volatile price of natural gas in recent years. Each \$1.00 fluctuation in the price changes operating costs by approximately \$1.60 per barrel [50]. Past variations in the prices of both natural gas and crude oil have altered production at heavy oil operations in the United States [51].

Oil sands production economics. Oil sands production in Alberta provides a large body of economic data from which to glean insights into production economics. Significant capital has already been invested, and announced projects indicate additional spending in the future. From 1996 to 2004, the Alberta oil sands industry spent an estimated \$25 billion on new projects with an additional \$57 billion in spending planned for 2006-2011 [55]. While early production costs were estimated at C\$35 per barrel, efficiency gains and increased economies of scale between the early 1980s and the late 1990s dropped the operating costs to less than C\$13 per barrel for an integrated mining and upgrading operation. However, in recent years the cost of oil sand production has risen, primarily due to rising energy costs and to higher capital costs [53].

The term C\$ refers to Canadian dollars. In this report, a dollar sign (\$) refers to U.S. dollars unless otherwise indicated.

The operating costs for bitumen are linked to the price of natural gas as natural gas is used for steam generation and bitumen upgrading. The rule of thumb in the Canadian oil sands industry is that 1 MCF of natural gas is necessary to produce one barrel of bitumen [54]. The present total cost of an integrated mining and upgrading operation is estimated at \$32-\$35 per barrel [54]. Upgrading is essential as the price of bitumen has averaged 51% of that of WTI crude in recent years [55]. Despite this plethora of data, the large U.S. oil sands deposits, located predominantly in Utah, have significantly different characteristics than those in Alberta and the economics of a Utah oil sands industry may be noticeably different than the Canadian experience.

MCF refers to one thousand cubic feet.

Oil shale production economics. Oil shale is the least understood of the three resources examined, as new technologies, still in the research and development phase, have the potential to drastically alter the economics of oil shale production. Despite a long history of activity in the oil shale industry, there is not a large body of industrial knowledge based on successful operations from which to draw, so published costs for oil shale production have ranged from \$10-\$95 per barrel [6,56]. These cost estimates are generated either by companies involved in developing oil shale resources using cost estimates based on engineering calculations or by analysts at various government agencies and think tanks. Actual operating costs, determined through pilot plants and

small demonstration units, will be needed before larger-scale commercial plants can be constructed. This process can take several years.

The different technologies of mining followed by surface retorting and of in situ retorting have the possibility of drastically different economics [57]. By applying inflation factors to published costs for the Colony and Union projects of the 1970s and 1980s and other published design studies from the same era, the Rand Corporation estimated that a 50,000 BOPD mining and surface retorting plant would have capital costs of \$5-\$7 billion and operating expenses of \$17-\$23 per barrel. The Rand Corporation also estimated that WTI Crude would have to be priced at \$70-\$95 per barrel for a first generation oil shale plant to be profitable [6]. In contrast, based on the experience of operating the Alberta-Taciuk Processor, a surface retorting technology, at a demonstration level in Australia, a full-sized plant incorporating 13 Alberta-Taciuk reactors to produce 157,000 BOPD of synthetic crude oil was projected to cost \$3.5-\$4.0 billion and have operating costs of \$7.50-\$8.00 per barrel [13].

The economics of in situ oil shale production are based largely on information released by Shell Oil relative to their ICP technology. Shell has stated that their technology may be profitable at an oil price of \$30 per barrel [6]. With current electric heater technology, the cost of heating equates to \$12-\$15 per barrel. A 100,000 BOPD operation would require 1.2 GW of dedicated electric generating capacity.

Socioeconomics of unconventional fuel development. Increased development of unconventional fuels will have varying social and economic impacts. The states most likely to experience rising production of these resources are all current producers of crude oil and natural gas. Jobs in these industries pay significantly better than the average job, and these pay differentials can be expected to continue with rising production [58].

Increased heavy oil production is likely to have minimal impacts for the producing areas. The areas most likely to see increased production, including Kern County, California, a three-county area in southern California, and the North Slope Borough, Alaska, already have significant oil production, although production has been declining since the 1980s. Any increase in heavy oil production would offset this decline and maintain the petroleum industry in these areas.

Development of oil sands and oil shale has a strong possibility of altering the economies of the areas where these resources are located (i.e. Colorado and Utah). Oil sands and oil shale production growth will increase in-migration to the area, with resulting population and workforce growth. While additional jobs and economic growth are desirable, rapid in-migration tends to strain local resources and infrastructure such as housing, schools, utilities, sanitation and roads. Some of these impacts can be mitigated through planning and permitting, but development of a large-scale oil sands and/or oil shale industry will alter the economic and social structure of nearby communities.

Unconventional fuel development under the Energy Policy Act of 2005. At present, oil shale and oil sands development are proceeding under specific timelines and mandates set by the Energy Policy Act of 2005 (EPAct). Although the EPAct encourages further development of all strategic unconventional fuels, heavy oil development beyond current production arenas and levels is not under active agency review. The

The Shell ICP process produces a refinery-ready shale oil that will not require partial upgrading prior to transportation to a refinery.

A gigawatt (GW) is equal to one billion watts.

Bureau of Land Management (BLM) is in the process of preparing a Programmatic Environmental Impact Statement (PEIS) for a commercial leasing program for oil shale and oil sands on the public lands. The PEIS is intended to satisfy threshold analysis obligations under the National Environmental Policy Act (NEPA) and provide a basis for amending existing BLM management plans under the Federal Land Policy and Management Act (FLPMA) for those areas selected for commercial oil sands and oil shale development. (Should commercial oil sands or oil shale development proceed, NEPA and FLPMA compliance requirements will continue to attach to the BLM's individual commercial oil shale and oil sands leasing decisions and to subsequent project development decisions.) Additionally the BLM has revised existing oil sands regulations and is currently drafting regulations for oil shale development.

Six Research, Development and Demonstration (RD&D) leases on small test sites on the public lands have been issued by the BLM in order to test and refine oil shale technologies. Five of the RD&D lease sites are located in Colorado and involve in situ technologies. The sixth RD&D lease site is located in Utah and involves a surface retort method.

Following completion of the PEIS, the EPLA directs the Secretary of Interior to consult with the affected states prior to deciding whether to issue any federal oil sands or oil shale leases. If it is determined that commercial development of oil sands or oil shale should proceed on the public lands, several important environmental issues and land use questions will need to be addressed.

Land and resource management issues. While oil shale and oil sands resources are predominantly located on federal land, these federal lands are interspersed with state and private lands. Thus, construction of industrial infrastructure and management of attendant environmental impacts may require obtaining rights of way and access to nearby state, tribal or private lands. In many instances, federally protected sensitive lands (including wilderness, wilderness study areas, national parks and national monuments) are in proximity to or co-located with the oil sands and oil shale resources. Management practices and mitigation measures that comport with the statutory protections afforded these lands will need to be developed and implemented.

Additionally, several animal and plant species protected under the Endangered Species Act reside in the areas of Colorado, Utah and Wyoming that are currently being evaluated as potential areas for unconventional fuel development by the BLM. The Migratory Bird Treaty Act, the Bald Eagle Protection Act and state law protections are also likely to be relevant to the manner in which commercial development of unconventional resources can proceed on the public lands.

Air and water quality management. Adequate measures will need to be developed and implemented to insure that commercial oil sands and/or oil shale activities comply with applicable air and water quality standards for the areas selected for development. The Clean Air Act, the Clean Water Act, the Safe Water Drinking Act, the Colorado River Basin Salinity Control Act, and applicable state laws all will be relevant to unconventional fuel resource development. Although emissions associated with climate change are not yet federally regulated, it should be expected that such a regulatory scheme will be finalized and relevant to future commercial oil sands and oil shale development.

Water consumption. Water consumption also will be an issue in the context of unconventional fuel development. Due to shifting and increased population demands, as well as recent dry weather conditions and dropping reservoir levels, it is unclear whether the Colorado River can continue to meet the anticipated water needs of the Colorado River Basin States and of Mexico, even without adding the consumptive water demands of unconventional fuel development. Moreover, within Colorado, Utah and Wyoming, most of the surface waters have been allocated under prevailing state law water regimes.

Policy questions. Commercial development of oil sands and/or oil shale on the public lands will raise several energy and resource management policy issues. In particular: (1) the balance between preserving existing landscapes and developing unconventional energy resources on the public lands; (2) the carbon emissions issues attendant to developing unconventional fuel resources; (3) the “energy in, energy out” calculus of developing unconventional fuel resources; and (4) the policy issues associated with developing these resources through highly water-consumptive technologies in the arid West.

References

- [1] Energy Information Administration (EIA) Reports. Strong Growth in World Energy Demand is Projected Through 2030. <http://www.eia.doe.gov/neic/press/press271.html> (accessed February 27, 2007). Press Release on June 20, 2006.
- [2] International Energy Agency. World Energy Outlook 2005: Middle East and North Africa Insights. *SourceOECD Energy* **2005**, 2005(26), pp i-631. Also available at <http://www.iea.org/textbase/nppdf/free/2005/weo2005.pdf>.
- [3] Dammer, A.R. *Strategic Significance of America's Oil Shale Resource*. 2005 EIA Midterm Energy Outlook Conference, U.S. Department of Energy, Washington, D.C., April 12, 2005. Also available at <http://www.eia.doe.gov/oiaf/archive/aeo05/conf/pdf/dammer.pdf>.
- [4] Alberta Energy and Utilities Board. *Oil Reserves and Production: Alberta*, Alberta Energy and Utilities Board: Calgary, Alberta, 2006. Also available at http://www.energy.gov.ab.ca/docs/oilsands/pdfs/PUB_osgenbrf2004.pdf.
- [5] Dyni, J.R. Geology and Resources of Some World Oil-Shale Deposits. *Oil Shale* **2003**, 20(3), pp 193-252. Also available at http://www.krij.ee/oilshale/vol_20_3.html.
- [6] Bartis, J.T.; LaTourrette, T.; Dixon, L.; Peterson, D.J.; Cecchine, G. *Oil Shale Development in the United States*; MG-414-NETL; RAND Corporation: Santa Monica, CA, 2005.
- [7] Centre for Energy – Oil & Natural Gas. What are Oil Sands and Heavy Oil? <http://www.centreforenergy.com/silos/ong/ET-ONG.asp> (accessed February 28, 2007).
- [8] Naslund, H.R. Geology 111 – Energy Resources. <http://www.geol.binghamton.edu/faculty/naslund/Geol.111.lect33a.html> (accessed August 2, 2007). University of Oregon.
- [9] http://en.wikipedia.org/wiki/Heavy_crude_oil#Origin
- [10] http://en.wikipedia.org/wiki/Tar_sands
- [11] Cornelius, C.D. Classification of Natural Bitumen: A Physical and Chemical Approach. In *Exploration for Heavy Crude Oil and Natural Bitumen*, Meyer, R.F., Ed.; Studies in Geology, Vol. 25; AAPG: Tulsa, OK, 1987; pp 165-174.
- [12] Johnson, H.R.; Crawford, P.M.; Bunger, J.W. *Strategic Significance of America's Oil Shale Resource: Volume I, Assessment of Strategic Issues*, AOC Petroleum Support Services, LLC: Washington, D.C., March 2004.
- [13] Johnson, H.R.; Crawford, P.M.; Bunger, J.W. *Strategic Significance of America's Oil Shale Resource: Volume II, Oil Shale Resources, Technology and Economics*, AOC Petroleum Support Services, LLC: Washington, D.C., March 2004.

- [14] Buschkuehle, B.E.; Grobe, M. Geology of the Upper Devonian Grosmont Carbonate Bitumen Deposit, Northern Alberta, Canada. In *American Association of Petroleum Geologists Annual Meeting*, Dallas, TX, 2004; AAPG: Dallas, TX, 2004. Also available at http://www.ags.gov.ab.ca/activities/conference_presentations.html.
- [15] Advanced Resources International. *Undeveloped Domestic Oil Resources: The Foundation for Increasing Oil Production and a Viable Domestic Oil Industry*; U.S. Department of Energy, 2006. Also available at [http://fossil.energy.gov/programs/oilgas/eor/Undeveloped Domestic Oil Resources Provi.html](http://fossil.energy.gov/programs/oilgas/eor/Undeveloped_Domestic_Oil_Resources_Provi.html).
- [16] Bidinger, C.R.; Dillon, J.F. Milne Point Schrader Bluff: Finding the Keys to Two Billion Barrels. SPE International Heavy Oil Symposium, June 19-21, 2005, Calgary, Alberta; Society of Petroleum Engineers: Richardson, TX, 1995; SPE 30289.
- [17] National Energy Technology Laboratory. U.S. Heavy Oil Database. <http://www.netl.doe.gov/technologies/oil-gas/Software/database.html> (accessed February 27, 2007).
- [18] Pemex. *Las Reservas de Hidrocarburos de México: Evaluación al 1 de enero de 2006*; Pemex Exploración y Producción, 2006.
- [19] Reid, T.B.; Mikels, R. *U.S. Tar Sands Deposits*; Department of Energy, Office of Fossil Energy, 1993. Also available at <http://www.oildrop.org/lib.html>.
- [20] Oblad, A.G.; Bunger, J.W.; Hanson, F.V.; Miller, J.D.; Ritzma, H.R.; Seader, J.D. Tar Sand Research and Development at the University of Utah. *Annual Review of Energy* **1987**, *12*, pp 283-356.
- [21] Ritzma, H.R. *Oil-impregnated Rock Deposits of Utah*, Map 47; Utah Geological and Mineralogical Survey, 1979. Also available at <http://geology.utah.gov/online/m/m-47.pdf>.
- [22] U.S. Office of Technology Assessment. *An Assessment of Oil Shale Technologies, Volume I*; PB80-210115; Congress of the United States: Washington, D.C., 1980.
- [23] Macauley, G. *Geology of the Oil Shale Deposits of Canada*; Open-File Report 754; Geological Survey of Canada, 1981. Also available at http://ess.nrcan.gc.ca/esic/index_e.php.
- [24] California Department of Conservation; Division of Oil, Gas & Geothermal Resources. Monthly Production and Injection Databases. http://www.conservation.ca.gov/DOG/prod_injection_db/index.htm (accessed October 1, 2006).
- [25] Advanced Resources International. *Undeveloped Domestic Oil Resources: The Foundation for Increasing Oil Production and a Viable Domestic Oil Industry*; U.S. Department of Energy, 2006. Also available at [http://fossil.energy.gov/programs/oilgas/eor/Undeveloped Domestic Oil Resources Provi.html](http://fossil.energy.gov/programs/oilgas/eor/Undeveloped_Domestic_Oil_Resources_Provi.html).
- [26] Pemex. *Pemex 2006 Annual Report*, Pemex Corporate Finance Office: C. P. 11311 México. Exploration and Production. Also available at <http://www.pemex.com/index.cfm?action=content§ionID=11&catid=149&contentID=2711>.
- [27] Canadian Association of Petroleum Producers (CAPP). *Canadian Crude Oil Production and Supply Forecast, 2006-2020*, CAPP: Calgary, Alberta, May 2006. Also available at <http://www.capp.ca/raw.asp?x=1&dt=NTV&e=PDF&dn=103586>.
- [28] Alberta Energy and Utilities Board Staff. *Alberta's Energy Reserves 2006 and Supply/Demand Outlook 2007-2015*; ST98-2007; Alberta Energy and Utilities Board: Calgary, Alberta, June 2007.
- [29] Oil Sands. <http://www.energy.gov.ab.ca/89.asp> (accessed June 18, 2007). Government of Alberta; Energy.
- [30] Temple Mountain Energy, Inc. U.S. Oil Sands Production Project. <http://www.templemountainenergy.com/> (accessed September 7, 2007).
- [31] Earth Energy Resources Inc. <http://www.earthenergyresources.com/index.php> (accessed September 7, 2007).
- [32] Strycker, A.R.; Wadkins, R.; Olsen, D.K.; Sarkar, A.K.; Ramzel, E.B.; Johnson, W.I.; Pautz, J. *Feasibility Study of Heavy Oil Recovery in the United States*; NIPER/BDM-0225; BDM-Oklahoma, Inc.: Bartlesville, OK, March 1996.
- [33] Masliyah, J.; Zhou, Z.J.; Xu, Z.; Czarnecki, J.; Hamza, H. Understanding Water-Based Bitumen Extraction from Athabasca Oil Sands. *Canadian Journal of Chemical*

- Engineering* **2004**, 82, pp 628-654.
- [34] Ophus, K. Removal of Hydrocarbons from Particulate Solids. International Patent Application number: PCT/CA2004/001826, April 20, 2004.
- [35] Sandler, K. and Davis, P. In Situ Bitumen Overview and Activity Update in the Province of Alberta. SPE/PS-CIM/CHOA International Thermal Operations and Heavy Oil Symposium, November 1-3, 2005, Calgary, Alberta; Society of Petroleum Engineers: Dallas, TX, 2005; SPE 97800.
- [36] McLendon, T.R.; Bartke, T.C. *Tar Sand, Technology Status Report*; DOE/METC-91/0274 (DE91002070); Office of Fossil Energy, U.S. Department of Energy: Morgantown, WV, 1990.
- [37] Flint, L. *Bitumen Recovery Technology: A Review of Long Term R&D Opportunities*; LENEFF Consulting Limited, 2005.
- [38] Gray, M. Research Challenges for Sustainable Oil Sands Production. Research presentation to the Utah Heavy Oil Program, University of Utah, March 15, 2007.
- [39] Koel, M. Estonian Oil Shale. www.kirj.ee/oilshale/Est-OS.htm (accessed June 18, 2007). Oil Shale, A Scientific-Technical Journal, Oil Shale Extra.
- [40] Shell Oil Company. Welcome to the Mahogany Research Project. http://www.shell.com/home/Framework?siteId=us-en&FC2=/us-en/html/iwgen/leftnav/zzz_lhn4_4_0.html&FC3=/us-en/html/iwgen/shell_for_businesses/exploration_production_shared/mahogany_shared/dir_mahogany.html (accessed October 1, 2006).
- [41] Vinegar, H.J. Shell Oil Company. Personal communication, July 2006.
- [42] Heidrick, T.; Bilodeau, V.; Godin, M. *Oil Sands Research Inventory*; Alberta Energy Research Institute: Edmonton, Alberta, March 2004. Also available at http://www.aeri.ab.ca/sec/new_res/docs/Oil_Sands_Public_Research_27Apr07.pdf.
- [43] Energy Information Administration. *Refinery Capacity Report 2007*; Department of Energy: Washington, D.C., June 2007. Also available at http://www.eia.doe.gov/oil_gas/petroleum/data_publications/refinery_capacity_data/refcapacity.html.
- [44] Energy Information Administration. Refinery Capacity and Utilization. http://onto.eia.doe.gov/dnav/pet/pet_pnp_top.asp (accessed December 13, 2006).
- [45] Gossen, S.; *Partial Upgrading of Heavy Oil and Bitumen: Strategic Value in Western Canada*, Canadian Heavy Oil Association, Calgary, Alberta, May 8, 2002. Also available at <http://www.ensyn.com/info/08052002.htm>.
- [46] Speight, J.G.; Özüm, B. *Petroleum Refining Process*, Marcel Dekker, Inc: New York, 2002.
- [47] Energy Information Administration. *Annual Energy Outlook 2007 with Projections to 2030*; DOE/EIA-0383(2007); U.S. Department of Energy: Washington, D.C., February 2007. Also available at <http://www.eia.doe.gov/oiaf/aco/index.html>.
- [48] Energy Information Administration. *International Energy Outlook 2007*; DOE/EIA-0484(2006); U.S. Department of Energy: Washington, D.C., May 2007. Also available at <http://www.eia.doe.gov/oiaf/ieo/index.html>.
- [49] Berry Petroleum. 2005 Form 10-K. <http://www.bry.com/index.php?page=investor> (accessed January 20, 2007).
- [50] Berry Petroleum. 2006 Form 10-K. <http://www.bry.com/index.php?page=investor> (accessed May 7, 2007).
- [51] Guntis, M. California Steam Produces Less: Other EOR Continues. *Oil & Gas Journal* **2002**, 100(15), pp 48-74.
- [52] Athabasca Regional Issues Working Group; Regional Municipality of Wood Buffalo; Fort McMurray Public Schools; Fort McMurray Catholic Board of Education; Northland School Division; Keyano College; Northern Lights Health Region. *Wood Buffalo Business Case 2005: A Business Case for Government Investment in the Wood Buffalo Region's Infrastructure*, Athabasca Regional Issues Working Group, March 2005. Also available at <http://www.oilsands.cc/pdfs/Wood%20Buffalo%20Business%20Case%202005.pdf>.
- [53] National Energy Board – Canada. *Canada's Oil Sands: Opportunities and Challenges to 2015: An Update*, National Energy Board – Canada, May 2004. Also

- available at <http://www.neb-one.gc.ca/clf-nsi/rnrgynfmtn/nrgyrprt/lsnd/pprtntsnd-chllngs20152004/pprtntsndchllngs20152004-eng.pdf>.
- [54] National Energy Board – Canada. *Canada's Oil Sands: Opportunities and Challenges to 2015: An Update*; National Energy Board – Canada, June 2006. Also available at <http://www.neb-one.gc.ca/clf-nsi/rnrgynfmtn/nrgyrprt/lsnd/pprtntsnd-chllngs20152006/pprtntsndchllngs20152006-eng.pdf>.
- [55] Canadian Association of Petroleum Producers. *Bitumen Pricing Methodology for SEC Reserves Disclosure*; Canadian Association of Petroleum Producers, September 2005. Also available at <http://capp.ca/raw.asp?x=1&dt=NTV&c=PDF&dn=91581>.
- [56] Bauman, J. Vernal Company Set to Exploit Oil Shale. *Deseret Morning News*. March 14, 2005.
- [57] Isaacson, Alan E. Western Oil Shale: Past, Present and Future. *Utah Economic and Business Review* **2006**, 66, pp 1-11.
- [58] Bureau of Labor Statistics. Quarterly Census of Employment and Wages. <http://stats.bls.gov/cew/home.htm> (accessed November 10, 2006).

1

Introduction

1 Introduction

Due to the current political climate in many oil-producing nations and the significant increases in global energy demand, United States energy policy proposals are once again focused on North American unconventional hydrocarbon resources for their potential to reduce future energy crises. The purpose of this report is to assess unconventional North American resources, summarize current technologies for extracting and processing the resources, identify the issues which will affect the economic viability of various resource development schemes, evaluate the socioeconomic costs to communities and states impacted by such development, and analyze the regulatory and environmental climate in which the resource development will operate.

1.1 Energy and Global Economic Development

In 2007, there are 6.6 billion people in the world, with 98% of the world's population growth in developing countries [1]. A tremendous rate of development, sparked largely by rapid economic expansion in India and China, has enormous implications for worldwide energy consumption. Figure 1-1 shows projected growth in energy consumption worldwide from 2004 to 2030 [2]. The strongest growth is in developing countries outside the Organisation for Economic Co-operation and Development (OECD) and is led by non-OECD Asia. Economic development and the rate of economic expansion are driven in a large part by the availability of energy. For the foreseeable future, the largest energy source will be petroleum as illustrated in Figure 1-2 [3]. Thus, the world economy and its state of economic development are significantly impacted by the cost of oil.

Non-OECD Asia includes China and India.

Figure 1-1. World marketed energy consumption by region.

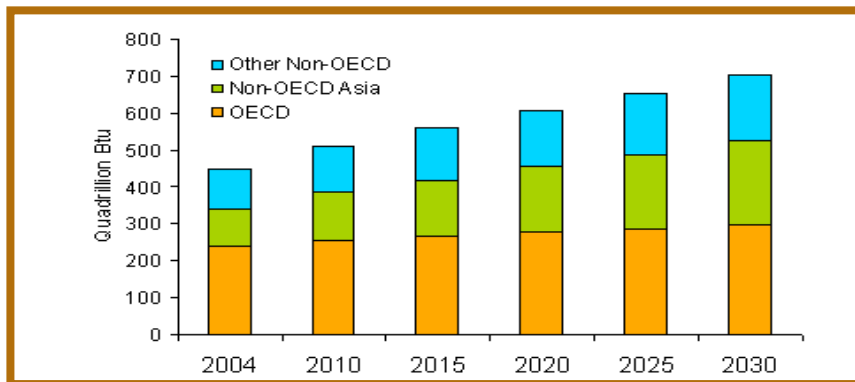

Source: International Energy Outlook 2007, Energy Information Administration

Marketed energy sources include electricity, propane, and gasoline. Non-marketed energy sources include wood and waste used for heating and cooking [2].

Figure 1-2. Total world primary energy consumption (% by fuel).

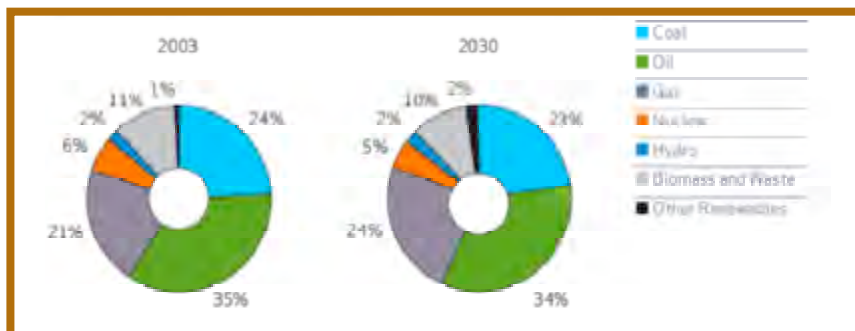

Source: World Energy Outlook 2005, Energy Information Administration

Compared to the rest of the world, the United States is more dependent on oil than on other energy sources. Figure 1-3 shows the historical and projected domestic energy consumption by fuel in quadrillion British Thermal Units (BTUs) between 1980 and 2030 [4]. In 2003, oil represented approximately 45% of domestic energy consumption compared to 35% of the world energy consumption. While oil as a percentage of worldwide energy consumption is projected to remain relatively constant through 2030, domestic oil consumption will continue to surpass 40% of total domestic energy consumption. This projected energy consumption indicates that the United States will be dependent on oil for its energy future through the first third of this century if not longer.

Figure 1-3. Historical and projected domestic energy consumption by fuel in quadrillion BTUs.

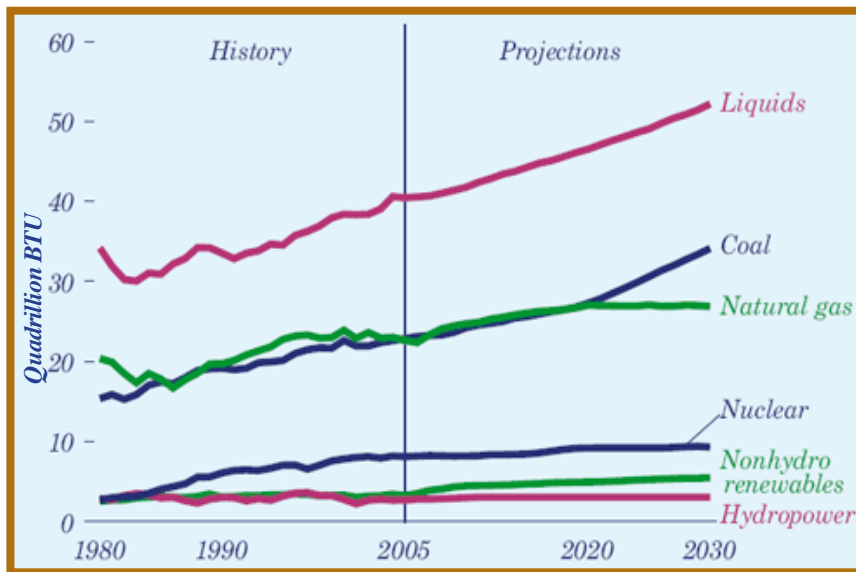

Source: Annual Energy Outlook 2007, Energy Information Administration

1.2 North American Unconventional Oil Resources

An unconventional fuel is one that is “not recoverable in its natural state through a well by ordinary production methods” [5] or that cannot be pumped without being heated or diluted. The unconventional fuels assessed in this report are classified as heavy oil/extra heavy oil, bitumen from oil sands, and oil shale. Conventional and unconventional fuels originated as organic material that was transformed through geologic time to its present form. More than 60% of the world’s petroleum resources occur in rocks older than 2 million year and younger than 65 million years. This time period represents a balance between the minimum amount of time required to form oil and gas and the maximum time where rocks have not yet eroded away or been heated to high temperatures [6]. To form conventional and unconventional fuels, organic material was buried in fine grained sediments in an oxygen poor environment. This buried material was first converted to kerogen through diagenesis at shallow depths and temperatures below 122°F (50°C). Hence, kerogen is an immature form of organic material and a precursor to oil. This kerogen was further converted to oil at depths of 1.2-2.4 miles (2-4 kilometers) and temperatures of 122°-212°F (50°-100°C). At great depths (2.4-4.3 miles or 4-7 kilometers) and higher temperatures (212°-392° F/100°-200° C), the oil was converted to natural gases including propane and butane. Methane formed from the conversion of complex natural gases at even greater depths (more than 4.3

Diagenesis is a biological, chemical, or physical change that a sediment undergoes at low temperatures and pressures. Change at high temperatures and pressures is called metamorphism [7].

miles or 7 kilometers) and at temperatures that exceeded 392°F (200°C) [6]. Heavy and extra heavy crude oil are a biodegraded form of oil that occur when lighter oil fractions are lost or are consumed by bacteria in the reservoir, leaving the heavier molecules behind [8]. Oil sands are an extremely heavy form of crude oil [9].

Heavy oil, extra heavy oil, and bitumen from oil sands, all organic liquids, are classified by their American Petroleum Institute (API) gravity and viscosity (see Section 3). The API gravity scale, graduated in degrees, was designed so that most hydrocarbon liquids would be in the range from 10 to 70 degrees. Light crude oil has an API gravity that exceeds 31.1° and medium oil has an API gravity between 31.1° and 22.3° [5]. Heavy oil has an API gravity of 10°-22.3° and viscosity of 100-10,000 cP at 60°F (15.6°C); extra heavy oil has an API gravity below 10° and viscosity of 100-10,000 cP at 60°F (15.6°C); and bitumen has viscosity above 10,000 cP at 60°F (15.6°C) [10].

Oil shale has a distinct classification from heavy oil and bitumen. As noted above, it is a fine-grained sedimentary rock rich in kerogen where the inorganic and organic matter are inextricably combined. All known processes for disengaging the kerogen from the inorganic matrix and for converting the kerogen to oil require heat input (see Section 4.3). Upon heating of the source rock, kerogen can produce crude oil, natural gas, and/or graphite [12,13].

How large is the North American unconventional oil resource? Figure 1-4 puts the size of the resource in perspective relative to proven and unproven conventional oil reserves [14]. A conservative estimate of the total world in-place oil shale resources are approximately 2.9 trillion barrels [15]. If half this resource could be exploited, it would surpass the total proven conventional oil reserves. The 2.0 trillion barrels of proven oil shale resources in the United States constitute the bulk of the oil shale resource worldwide in both quantity and quality. The Rand report [16] puts the range of recovery at 500 billion to 1.1 trillion barrels depending on the percent recoverable and accessible. However, even the conservative estimate translates into a 270-year supply if shale oil were to provide one-quarter of the United States petroleum demand of 20 million barrels a day.

Figure 1-4. Size of world conventional oil reserves compared to U.S. oil shale and Canadian oil (tar) sands reserves.

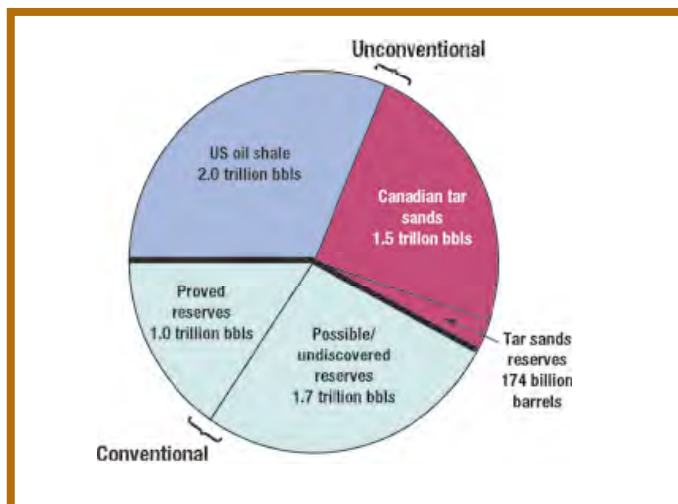

Source: A. R. Dammer, *Strategic Significance of America's Oil Shale Resource*, 2005

The definition presented here for heavy oil, extra heavy oil, and bitumen is from the United Nations Institute for Training and Research/United Nations Development Programme Information Centre for Heavy Crude and Tar Sands (UNITAR) [10]. Although the Department of Energy (DOE) uses the World Petroleum Congress definition for heavy oil [11], most published information for the United States and Canada is based on the UNITAR definition. Mexico uses a definition for heavy oil based on an API gravity of 27° or below.

Centipoise (cP) is one hundredth of a poise, a unit of viscosity in the centimeter-gram-second unit system.

The terms oil sands and tar sands are synonymous

1.3 Unconventional Oil Resources and the Global Petroleum Market

Ultimately, economic issues will control the development of North American unconventional oil resources. Historically, the global liquid fuels market has been controlled by a relatively few oil producers. Unconventional fuel resource development may present an opportunity for the United States to achieve greater oil and energy independence than it currently enjoys. The cost of oil dependence to the U.S. economy has been significant. Figure 1-5 [17] shows the breakdown of those costs assuming a competitive oil price of \$13 per barrel [18] and then computing costs based on the actual price of the oil. These costs include the transfer of wealth from oil consumers to oil producers, a Gross Domestic Product (GDP) loss because of the economy's diminished ability to produce due to the scarcity of energy, and a GDP "macroeconomic adjustment" because of losses of output in the economy due to inflation and unemployment [17].

The competitive oil price refers to the price that oil would have been if world oil markets had been competitive. Most estimates put the competitive price below \$13 per barrel [18].

Figure 1-5. Costs of oil dependence to the U.S. economy from 1970-2006 assuming a constant competitive world oil price of \$13 per barrel.

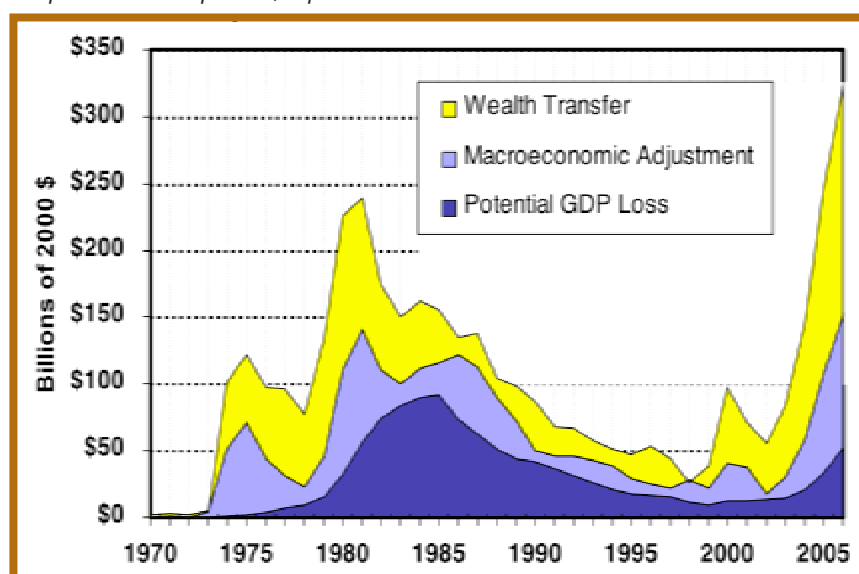

Source: D. L. Greene, et al., *Oil Independence: Achievable National Goal or Empty Slogan?*, Transportation Research Board Annual Meeting 2007

As oil impacts primarily the transportation sector of the U.S. economy, increasing engine efficiency, increasing the use of alternate transportation fuel sources, improving technologies for producing conventional oil, and producing petroleum from unconventional sources will all play a role in achieving greater oil independence. With the exception of heavy oil production using steam injection, petroleum production from unconventional sources is not a mature field. Hence, significant investment would be required in all aspects affecting unconventional oil utilization if it were to proceed on a commercially significant scale and thereby make a greater contribution to global or national energy security.

1.4 Heavy Oil

North American heavy oil/extra heavy oil resources occur in the United States, Canada and Mexico (see Section 3.1). The three largest North American deposits are the Lloydminster

deposits in western Canada containing 101.7 billion barrels original oil in place (OOIP) [19], a series of deposits in California with 75.9 billion barrels OOIP, and the deposits in the Schrader Bluff/West Sak/Ugnu area on the North Slope of Alaska with 25 to 30 [20,21] billion barrels OOIP. The remaining heavy oil resources in North America are distributed in deposits listed in the U.S. Heavy Oil Database [22] (153 deposits greater than 50 million barrels OOIP) and in heavy oil deposits in Mexico [23].

OOIP refers to oil prior to any production.

The total remaining oil in place in the United States, exclusive of Alaska, is estimated at 73.4 billion barrels with 91% of this resource total in the state of California (see Table 3-1) [24]. Mexico has a series of fields containing medium and heavy oil. The total estimated heavy oil resource in these fields is approximately 19 billion barrels OOIP or 57% of the total remaining proved, probable and possible oil in place in Mexico (see Table 3-2) [23]. A key feature of Mexican heavy oil deposits is that viscosities are low enough that the oils are produced using conventional methods. Most heavy oils are produced using steam injection technologies (see Section 4.1).

Remaining oil in place takes into account cumulative production.

1.5 Oil Sands

The presence of 1.7 trillion barrels of oil in the form of bitumen in western Canada has led to the development of a large oil sands industry in Canada. Of these total reserves, 174 billion barrels are proven reserves that can be recovered using current technology with an estimated 315 billion barrels recoverable with technology improvements [25]. Canadian production of synthetic crude oil and bitumen from oil sand deposits currently stands at about 1.2 million BOPD. Very large resource development projects are underway, with production projections of 3 million BOPD by 2015 [26].

BOPD refers to barrels of oil per day.

The largest oil sand deposits in the United States are found in the state of Utah with proven reserves of about 8-12 billion barrels OOIP [27-30]. Significant oil sands deposits are also found in California and Texas, but data relating to these deposits is very sparse as they are associated with the heavy oil in their respective areas. Alabama is estimated to have 1.8 billion barrels of measured and 4.6 billion barrels of speculative oil sand resource. Similarly, western Kentucky is estimated to have 1.7 billion barrels of measured and 1.7 billion barrels of speculative oil sand resource [31].

1.6 Oil Shale

The majority of the oil shale deposits in the United States lie in the Green River Formation of Colorado, Utah, and Wyoming. This formation alone may contain as much as 1.8 trillion barrels of oil and is one of the highest quality shales in the world. The widely studied Piceance formation in Colorado contains deposits more than 500 feet (152 meters) thick that are located beneath 500 feet (152 meters) of sedimentary rock. However, some portions lie in regions of up to 2,000 feet (610 meters) of overburden. Most of this formation yields more than 25 gallons per ton of raw material, which translates into nearly 2.5 million barrels per acre [14].

One barrel of oil contains 42 gallons.

The technology to remove oil shale with high enough efficiency to yield high returns has yet to be fully explored, and some deposits lie in regions where shale oil will be difficult or impossible to recover, such as those beneath towns and those where there are ecological or environmental concerns.

1.7 Upstream Processing

Unconventional oil deposits require upstream and downstream processing. Upstream

processing refers to the extraction/production of the oil from the deposit. This oil is typically extremely viscous and is composed of very high molecular weight compounds. Downstream processing, including upgrading and refining, produces marketable petroleum products.

Heavy oil has been produced in the United States for over 80 years [32]. Steam injection remains the most prominent production process for “conventional” heavy oil. Over the last ten years, advances in sensing and monitoring methods for steam injection have meant that California heavy oil recovery projects are profitable in the oil price range of \$30-\$35 (see Section 6.1). Nevertheless, project profitability is directly impacted by the energy source used for steam generation and by the cost of that source. In California heavy oil production, natural gas is the primary energy source [33]. As heavy oil production in California continues to decline, high natural gas prices may be contributing to that decline. The decline may not be arrested unless some large projects are initiated.

With oil sands production, asphalt-like bitumen must be extracted from the oil sands, a mixture of sand, water, clay, and bitumen. In Canada, mining followed by surface extraction is the technique of choice for the production of bitumen from shallow oil sands deposits. Over the last 30 years, the most common extraction method, which uses hot water, has been optimized with appropriate additives and solvents [34,35]. Water usage, residual oil on the discarded sand, and the need for large tailings ponds are some of the drawbacks of this technology. Nevertheless, about 60% of the oil produced from oil sands in Canada utilizes this technique. An in situ process that employs steam injection, Steam Assisted Gravity Drainage (SAGD), accounts for nearly all of the rest of production [36].

Canadian oil sands production is and will continue to be affected by natural gas availability and price; natural gas provides process heat for bitumen recovery and extraction and is used to generate steam for SAGD. An integrated mining/surface extraction process requires 700 cubic feet (20 cubic meters) of natural gas to produce one barrel of bitumen while an in situ process such as SAGD requires 1,200 cubic feet (34 cubic meters) per barrel [26]. High natural gas prices in North America are a reflection of the inability of natural gas production to keep pace with demand. In Canada, despite record drilling, natural gas production has declined or been flat for the past several years, and reserve additions have approximately equaled or have been lower than production, indicating flat supply in the future [37].

Application of either surface mining or in situ processing for oil production from U.S. oil sands will be challenging. Large volumes of accessible deposits are not available in U.S. reservoirs. Hence, it will probably be necessary to operate small (1000 - 5,000 BOPD) plants at multiple locations. For a mining and surface extraction operation, special mining methods will be required to mine and crush the consolidated rock that forms much of these oil sand deposits. Special additives may be necessary to get good recovery efficiencies from a surface hot-water extraction process [38]. Solvent extraction technologies may prove useful under the constraints imposed by U.S. resources, however, the use of certain solvents may be limited due to environmental concerns [39]. Application of in situ technologies requires further evaluation due to consolidated nature of some of the sands and the vertical heterogeneity of the resource.

Two companies have announced pilot scale/demonstration scale projects using solvent extraction technologies for oil recovery from Utah oil sands, although technical project details have not been made public.

It is possible that very thick, deeper shale deposits would be good candidates for in situ operations while shallower thinner beds could be produced using surface retorts.

In contrast to oil sands, enormous quantities of oil shale that would support large-scale production operations are found in Utah and Colorado. Some form of thermal treatment (either on the surface or in situ) is required to produce oil from oil shale. Several on-surface retorting technologies have been reported and are ready for use [40-42]. If mining and subsequent reclamation aspects are addressed, these on-surface retorting facilities would be feasible. Oil from these operations is partially upgraded and mild hydrotreatment may be adequate to make the oil refinery-ready. The feasibility of an in situ heating method to produce oil from shale has been confirmed by Shell for their In situ Conversion Process (ICP) in documents made public thus far [43,44]. Some of the major mining and reclamation considerations are avoided by using the in situ option but, in general, more energy is required to produce a barrel of oil by this method than by a surface processing technique. Also, it is not yet clear the role that geologic complexities will play in the process.

Shale oil contains alkenes (also called olefins), which are unstable and unsaturated hydrocarbons containing at least one C=C (carbon-carbon double bond). Hydrotreatment stabilizes the shale oil by adding hydrogen to unsaturated bonds and removing sulfur, nitrogen, oxygen, and trace metals from larger organic chains.

1.8 Downstream Processing and Markets

Finding markets for heavy oils produced from oil sands or oil shale will be challenging. The North American bitumen market is immature and illiquid with no posted prices for bitumen. In the past few years, the price of bitumen has averaged 51% of West Texas Intermediate crude [45]. As recently as 2003, shale oil was not competitive with petroleum, natural gas, or coal on the world market. Nevertheless, it is still used in several countries like Estonia that possess easily exploitable deposits of oil shale but lack other fossil fuel resources [46].

Heavy oils from oil sands and oil shale must be upgraded to a synthetic crude oil to be acceptable at many refineries that can only process light crude oils. Upgrading reduces the oil viscosity, increases the hydrogen to carbon ratio (H/C), reduces the molecular weight, and may significantly reduce or remove impurities that are problematic for most refineries. Since upgrading constitutes 90% of the downstream processing [47], a central facility that provides both upgrading and refining capacity could be economically viable depending on the location, the quality of the oil produced, the refining market at the time, available pipelines, energy sources (gas, coal, etc.) in the vicinity, the qualities of other crude oils being produced at the time, and a number of other factors. Partial upgrading renders the heavy oil/bitumen suitable for transportation via pipeline to a refinery for further downstream processing by reducing its viscosity and density [48].

1.9 Economic Issues

The economics of heavy oil production in California and bitumen/heavy oil production from Canadian oil sands are well known for existing technologies. In contrast, there is presently no commercial scale production of oil from oil shale, so cost estimates for converting oil shale to useable products vary widely and are associated with a high level of uncertainty. In all three cases, a disruptive technology could change the entire economic picture.

Any U.S. unconventional fuel development will require a refining and transportation infrastructure that does not currently exist to bring refined products to market. Due to the location of the resources, most oil shale and oil sands development will occur in the Rocky Mountain states, where refineries are running at the highest capacity utilization in the country [49]. Hence, synthetic crude oil produced in the area will need to be transported to other regions for refining. The picture for heavy oil is similar with

refineries on the West Coast, the center for heavy oil production in the United States, running at high capacity utilization [49]. Two pipelines serve the area at the epicenter of oil sands and oil shale development, Colorado's Piceance Basin and Utah's Uinta Basin, but the rise in production of conventional fuel in the same area will require construction of additional pipeline capacity.

1.10 Legal and Environmental Issues

A wide range of potential land use issues and environmental resource impacts frame the subject of unconventional oil development. Land ownership controls what laws are applicable, what uses are allowed and what mitigation measures are required. The majority of the land in question is federally owned, but some lands also belong to states, Native American tribes, and private property owners. The Mineral Leasing Act and the Combined Hydrocarbon Leasing Act, as amended by the Energy Policy Act of 2005, the National Environmental Policy Act, the Federal Land Management and Planning Act, the Endangered Species Act, the Clean Air Act, and the Clean Water Act, among others, will regulate the type of development that can and will occur.

In the arid western United States, where the majority of domestic heavy oil, oil sands, and oil shale resources are located, the potential allocation of water for unconventional fuel development is expected to present significant policy questions. Water availability has been recognized as a potential limiting factor in the long term development of these industries. Surface mining and in situ production methods for oil sands both have a significant impact on fresh water resources. These include ground and surface withdrawal, waste from water treatment and long term tailings ponds management. Surface mining requires 2-4.5 barrels of fresh water for each barrel of bitumen produced [50]. The predominant method of in situ production, SAGD, requires approximately 3 water equivalent barrels of steam injected to produce one barrel of bitumen although process water recycling reduces water consumption to as low as 0.2 units per unit of bitumen produced [51]. Estimates for water usage associated with oil shale production from mining and surface retorting vary from 2.1-5.2 barrels of water per barrel of oil produced [16].

In Canada, the effect of water withdrawal from the Athabasca River for oil sands production and its consequent impact on the Peace-Athabasca Delta, the largest boreal delta in the world, has been listed by the Environment Canada as one of the threats to the integrity of the delta [52].

1.11 Summary

The issues surrounding the development of unconventional fuels in North America are shaped by the fields of engineering, geology, science, business, economics, law, and public policy. As this report is an update to the 1988 report, A Technical and Economic Assessment of Domestic Heavy Oil: Final Report [32], it cannot address all these fields in exhaustive detail. As a result, the Utah Heavy Oil Program (UHOP) of the Institute for Clean and Secure Energy at the University of Utah has created a digital repository of information relevant to North American heavy oil, oil sands and oil shale resources. The repository can be accessed via a text-based interface (<http://www.heavyoil.utah.edu>) or through a map server interface (http://map.heavyoil.utah.edu/website/uhop_ims). Information about the map server interface, which allows users to explore the UHOP repository in a geospatial setting, is found in Section 2 of this report.

Ultimately, unconventional oil resource development will be driven by economics and policy. Policy-wise, the strategic need for domestic oil resources could trump all other barriers and roadblocks. It is an exciting and challenging picture that will be explored in this report.

1.12 References

- [1] Population Reference Bureau. World Population Highlights: Key Findings from the 2007 World Population Data Sheet. http://www.prb.org/pdf05/05WorldDataSheet_Eng.pdf (accessed September 7, 2007).
- [2] Energy Information Administration. *International Energy Outlook 2007*; DOE/EIA-0484(2007); U.S. Department of Energy: Washington, D.C., May 2007. Also available at <http://www.eia.doe.gov/oiaf/ieo/index.html>.
- [3] International Energy Agency. World Energy Outlook 2005: Middle East and North Africa Insights. *Source OECD Energy*, **2005**, 2005(26), p 81.
- [4] Energy Information Administration. *Annual Energy Outlook 2007 with Projections to 2030*; DOE/EIA-0383(2007); U.S. Department of Energy: Washington, D.C., February 2007. Also available at <http://www.eia.doe.gov/oiaf/aeo/index.html>.
- [5] Centre for Energy – Oil & Natural Gas. What are Oil Sands and Heavy Oil? <http://www.centreforenergy.com/silos/ong/ET-ONG.asp> (accessed February 28, 2007).
- [6] Naslund, H.R. Geology 111 – Energy Resources. <http://www.geol.binghamton.edu/faculty/naslund/Geol.111.lect33a.html> (accessed August 2, 2007). University of Oregon.
- [7] Wikipedia. Diagenesis. <http://en.wikipedia.org/wiki/Diagenesis> (accessed June 10, 2007).
- [8] Wikipedia. Heavy crude oil. http://en.wikipedia.org/wiki/Heavy_crude_oil#Origin (accessed June 10, 2007).
- [9] Wikipedia. Tar sands. http://en.wikipedia.org/wiki/Tar_sands (accessed June 10, 2007).
- [10] Cornelius, C.D. Classification of Natural Bitumen: A Physical and Chemical Approach. In *Exploration for Heavy Crude Oil and Natural Bitumen*, Meyer, R.F., Ed.; Studies in Geology, Vol. 25; AAPG: Tulsa, OK, 1987; pp 165-174.
- [11] Martínez, A.R.; Ion, D.C.; DeSorcy, G.J.; Dekker, H.; Smith, S. Classification and Nomenclature Systems for Petroleum and Petroleum Reserves, 1987 Report. In *Proceedings of the Twelfth World Petroleum Congress*; John Wiley & Sons Limited: Chichester, UK, 1987; Vol. 5, pp 255-276.
- [12] Johnson, H.R.; Crawford, P.M.; Bunger, J.W. *Strategic Significance of America's Oil Shale Resource: Volume I, Assessment of Strategic Issues*, AOC Petroleum Support Services, LLC: Washington, D.C., March 2004.
- [13] Johnson, H.R.; Crawford, P.M.; Bunger, J.W. *Strategic Significance of America's Oil Shale Resource: Volume II, Oil Shale Resources, Technology and Economics*, AOC Petroleum Support Services, LLC: Washington, D.C., March 2004.
- [14] Dammer, A.R. *Strategic Significance of America's Oil Shale Resource*, 2005 EIA Midterm Energy Outlook Conference, U.S. Department of Energy, Washington, D.C., April 12, 2005. Also available at <http://www.eia.doe.gov/oiaf/archive/aeo05/conf/pdf/dammer.pdf>.
- [15] Dyni, J.R. Geology and Resources of Some World Oil-Shale Deposits. *Oil Shale* **2003**, 20(3), pp 193-252. Also available at http://www.krij.ee/oilshale/vol_20_3.html.
- [16] Bartis, J.T.; LaTourrette, T.; Dixon, L.; Peterson, D.J.; Cecchine, G. Oil Shale Development in the United States; MG-414-NETL; RAND Corporation: Santa Monica, CA, 2005.
- [17] Greene, D.L.; Leiby, P.; Patterson, P.; Plotkin, S.E.; Singh, M.K. *Oil Independence: Achievable National Goal or Empty Slogan?*; TRB 86th Annual Meeting Compendium of Papers CD-ROM, Transportation Research Board 86th Annual Meeting, Washington, D.C., January 21-25, 2007; Paper #07-1693. Also available at <http://pubsindex.trb.org/document/view/default.asp?lbid=801820>.
- [18] Greene, D.L.; Ahmad, S. *Costs of U.S. Oil Dependence: 2005 Update*, ORNL/TM-2005/45; Oak Ridge National Laboratory: Oak Ridge, TN, February 2005. Also available at <http://www-cta.ornl.gov/cta/Publications/Reports/CostsofUSOilDependence.pdf>.
- [19] Buschkuehle, B.E.; Grobe, M. Geology of the Upper Devonian Grosmont Carbonate

- Bitumen Deposit, Northern Alberta, Canada. In *American Association of Petroleum Geologists Annual Meeting*, Dallas, TX, 2004; AAPG: Dallas, TX, 2004. Also available at http://www.ags.gov.ab.ca/activities/conference_presentations.html.
- [20] Advanced Resources International. *Undeveloped Domestic Oil Resources: The Foundation for Increasing Oil Production and a Viable Domestic Oil Industry*, U.S. Department of Energy, 2006. Also available at http://fossil.energy.gov/programs/oilgas/eor/Undeveloped_Domestic_Oil_Resources_Provi.html.
- [21] Bidinger, C.R.; Dillon, J.F. Milne Point Schrader Bluff: Finding the Keys to Two Billion Barrels. SPE International Heavy Oil Symposium, June 19-21, 2005, Calgary, Alberta; Society of Petroleum Engineers: Richardson, TX, 1995; SPE 30289.
- [22] U.S. Energy Information Agency. U.S. Heavy Oil Database. <http://www.netl.doe.gov/technologies/oil-gas/Software/database.html> (accessed February 27, 2007).
- [23] Pemex. *Las Reservas de Hidrocarburos de México: Evaluación al 1 de enero de 2006*, Pemex Exploración y Producción, 2006.
- [24] Strycker, A.R.; Wadkins, R.; Olsen, D.K.; Sarkar, A.K.; Ramzel, E.B.; Johnson, W.I.; Pautz, J. *Feasibility Study of Heavy Oil Recovery in the United States*, NIPER/BDM-0225; BDM-Oklahoma, Inc.: Bartlesville, OK, March 1996.
- [25] Alberta Energy and Utilities Board. *Oil Reserves and Production: Alberta*, Alberta Energy and Utilities Board: Calgary, Alberta, 2006. http://www.energy.gov.ab.ca/docs/oilsands/pdfs/PUB_osgenbrf2004.pdf (accessed November 16, 2006).
- [26] National Energy Board – Canada. *Canada's Oil Sands: Opportunities and Challenges to 2015: An Update*, National Energy Board – Canada, May 2004. Also available at <http://www.neb-one.gc.ca/clf-nsi/rnrgynfmitn/nrgyrprt/lsnd/pprntnsndchllngs20152004/pprntnsndchllngs20152004-eng.pdf>.
- [27] Reid, T.B.; Mikels, R. *U.S. Tar Sands Deposits*, Department of Energy, Office of Fossil Energy, 1993. Also available at <http://www.oildrop.org/lib.html>.
- [28] Oblad, A.G.; Bunger, J.W.; Hanson, F.V.; Miller, J.D.; Ritzma, H.R.; Seader, J.D. Tar Sand Research and Development at the University of Utah. *Annual Review of Energy* **1987**, *12*, pp 283-356.
- [29] Ritzma, H.R. *Oil-impregnated Rock Deposits of Utah*, Map 47; Utah Geological and Mineralogical Survey: 1979. Also available at <http://geology.utah.gov/online/m/m-47.pdf>.
- [30] Oil Shale & Tar Sands Leasing Programmatic EIS Information Center. <http://ostseis.anl.gov/PEIS> (accessed August 10, 2007).
- [31] Kuuskraa, V.A.; Hammershaimb, E.C.; Pague, M. Major Tar Sand and Heavy-Oil Deposits of the United States. In *Exploration for Heavy Crude Oil and Natural Bitumen*; Meyer, R.F., Ed.; Studies in Geology, Vol. 25; AAPG: Tulsa, OK, 1987; pp 123-135.
- [32] Dowd, W.T.; Kuuskraa, V.A.; Godec, M.L. *A Technical and Economic Assessment of Domestic Heavy Oil: Final Report*. DOE/BC/10840-1; Interstate Oil Compact Commission: Oklahoma, OK, January 1988.
- [33] Kramer, D. CEO of the California Independent Petroleum Association. Comments on Staff Draft Report: Natural Gas Infrastructure Issues, Docket 99–CEO-VOL-1; Committee Hearing before the California Energy Resources Conservation and Development Commission, California Energy Commission: Sacramento, CA, June 5, 2001. Also available at www.energy.ca.gov/energyoutlook/documents/2001-06-05_naturalgas_hearing/CIPA_CEC_Testimony_Final.DOC.
- [34] Clark, K.A.; Pasternack, D.S. Hot Water Separation of Bitumen from Alberta Bituminous Sand. *Industrial and Engineering Chemistry* **1932**, *24*, pp 1410-1416.
- [35] Bichard, J.A. *Oil Sands Composition and Behavior Research: The Research Papers of John A. Bichard, 1957-1965*; AOSTRA Technical Publication Series 4; Alberta Oil Sands Technology and Research Authority: Edmonton, Alberta, 1987.
- [36] Alberta Energy and Utilities Board Staff. *Alberta's Energy Reserves 2006 and Supply/Demand Outlook 2007-2015*; ST98-2007; Alberta Energy and Utilities Board: Calgary, Alberta, June 2007.

- [37] Natural Gas Division of Natural Resources Canada. *Canadian Natural Gas: Review of 2004 & Outlook to 2020*; Natural Resources Canada: Ottawa, Ontario, 2006.
- [38] McLendon, T.R.; Bartke, T.C. *Tar Sand, Technology Status Report*, DOE/METC-91/0274 (DE91002070); Office of Fossil Energy, U.S. Department of Energy: Morgantown, WV, 1990.
- [39] Sepulveda, J.E.; Miller, J.D.; Oblad, A.G. Hot Water Extraction of Bitumen from Utah Tar Sands. *American Chemical Society, Division of Fuel Chemistry, Preprints* **1976**, 21(6), pp 110-122. From: American Chemical Society Meeting, San Francisco, CA, August 29-September 3, 1976.
- [40] U.S. Office of Technology Assessment. *An Assessment of Oil Shale Technologies, Volume I*; PB80-210115; Congress of the United States: Washington, D.C., 1980.
- [41] Koszarycz, R.; Padamsey, R.; Turner, L.R.; Ritchey, R.M. The AOSTRA Taciuk Processing- Heading into the Commercialization Phase. In *Proceedings of the 1991 Eastern Oil Shale Symposium*, Lexington, KY, November 30-December 2, 1991; pp 106-115.
- [42] Schmidt, S.J. New Directions for Shale Oil: Path to a Secure New Oil Supply Well into This Century: On the Example of Australia. *Oil Shale* **2003**, 20(3), pp 333-346. Also available at http://www.kirj.ee/oilshale/7_schmidt_2003_3s.pdf
- [43] Mut, S. *Shell Unconventional Resources Energy*. Testimony at the Oil Shale and Oil Sands Resources Hearing, Senate Energy and Natural Resources Committee, April 12, 2005. Also available at http://energy.senate.gov/public/index.cfm?FuseAction=Hearings.Testimony&Hearing_ID=1445&Witness_ID=4139.
- [44] Shell Oil Company. Welcome to the Mahogany Research Project. http://www.shell.com/home/Framework?siteId=us-en&FC2=/us-en/html/iwgen/leftnavs/zzz_lhn4_4_0.html&FC3=/us-en/html/iwgen/shell_for_businesses/exploration_production_shared/mahogany_shared/dir_mahogany.html (accessed October 1, 2006).
- [45] Canadian Association of Petroleum Producers. *Bitumen Pricing Methodology for SEC Reserves Disclosure*; Canadian Association of Petroleum Producers, September 2005.
- [46] Koel, M. Estonian Oil Shale. www.kirj.ee/oilshale/Est-OS.htm (accessed June 18, 2007). *Oil Shale, A Scientific-Technical Journal, Oil Shale Extra*.
- [47] Bruce, G.W. *Alberta Oil Sands in the Global Marketplace – Getting There?*, 4th Upgrading and Refining of Heavy Oil, Bitumen and Synthetic Crude Oil Conference, Edmonton, Alberta, September 25-27, 2006.
- [48] Heidrick, T.; Bilodeau, V.; Godin, M. *Oil Sands Research Inventory*; Alberta Energy Research Institute: Edmonton, Alberta, March 2004. Also available at http://www.aeri.ab.ca/sec/new_res/docs/Oil_Sands_Public_Research_27Apr07.pdf.
- [49] Energy Information Administration. *Refinery Capacity Report 2007*; Department of Energy: Washington, D.C., June 2007. Also available at http://www.eia.doe.gov/oil_gas/petroleum/data_publications/refinery_capacity_data/refcapacity.html.
- [50] National Energy Board – Canada. *Canada's Oil Sands: Opportunities and Challenges to 2015: An Update*; National Energy Board – Canada, June 2006. Also available at <http://www.neb-one.gc.ca/clf-nsi/rnrgynfntn/nrgyrprt/lsnd/pprntnsndchllngs20152006/pprntnsndchllngs20152006-eng.pdf>.
- [51] Devon Canada Corporation. Dover SAGD progress Review- Thermal heavy oil. <http://www.eub.ca/docs/products/osprogressreports/2005/2005AthabascaDevonDoverSAGD9045.pdf> (accessed July 20, 2007). Presentation dated April 28, 2005.
- [52] Environment Canada. Peace-Athabasca Delta, Alberta – Ramsar Site. <http://www.pnr-rpn.ec.gc.ca/nature/whp/ramsar/df02s06.en.html> (accessed February 10, 2007).

2

**Utah Heavy Oil Program ArcIMS®
Map Server Interface**

2 Utah Heavy Oil Program ArcIMS® Map Server Interface

The Utah Heavy Oil Program (UHOP) of the Institute for Clean and Secure Energy at the University of Utah has been commissioned to build a repository to hold information relevant to the resources of heavy oil, oil sands and oil shale in North America. UHOP has developed a map server interface to deliver dynamic maps and information via the internet. The goal is to give users the opportunity to explore the UHOP repository in a geospatial setting.

ArcIMS® is the scalable internet map server solution being used by UHOP to deliver these dynamic maps and information to users. It is widely used for geographic information web publishing to deliver maps, data and metadata to many users on the internet. ArcIMS® provides browser-based access to geographic information and relieves the burden on users to find, download and/or purchase Geographic Information System (GIS) software for exploring geospatial information. All that is required for users to interface with the UHOP map server is a fast internet connection and a compatible web browser. The current URL for the UHOP map server is http://map.heavyoil.utah.edu/website/uhop_ims.

2.1 UHOP ArcIMS® Map Server Interface

The UHOP map server interface is laid out in a series of frames including a title frame, a map frame, a toolbar frame, a table of contents/legend frame, an overview map frame, and a text frame. Each frame displays an HTML page that works in coordination with the pages in the other frames to provide information to users. UHOP has designed the frames to provide a concise and organized interface that the user can interact with and explore. Some of the available frames are shown in Figure 2-1.

Figure 2-1. Some of the frames available in the UHOP map server interface.

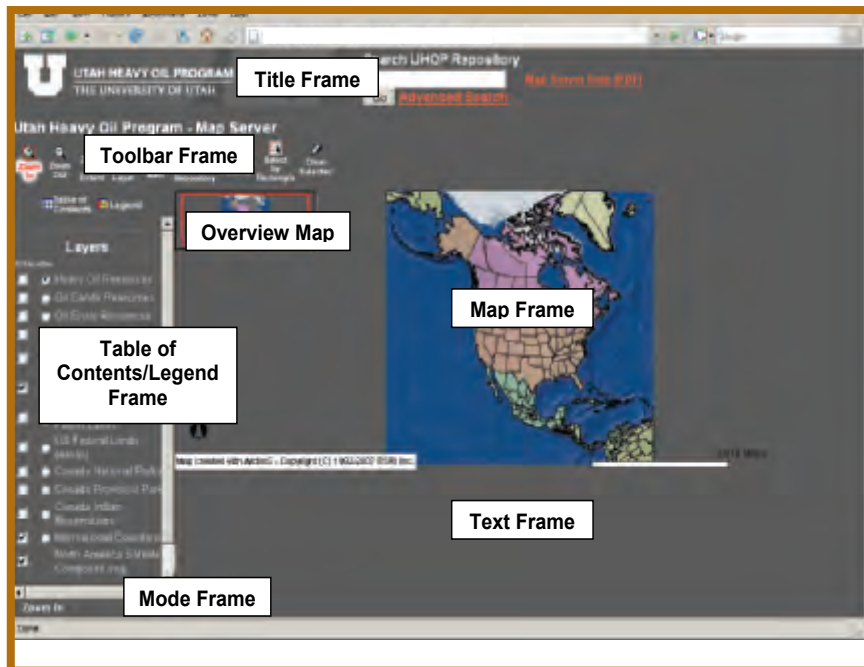











Source: Utah Heavy Oil Program

2.2 Toolbar Description

Currently, there are fourteen tools and buttons on the toolbar in the toolbar frame. Their functions are highlighted in Table 2-1 below. Three of the tools, Identify Results, Select by Rectangle, and Query UHOP Repository, are discussed in more detail in Section 2.5.

Table 2-1. Tools and buttons available for use with the UHOP map server.

	
	The Zoom In tool allows users to zoom in on the main map by either clicking on a location or by clicking and holding down the left mouse button while dragging the mouse to define a zoom area.
	The Zoom Out tool does the opposite of the Zoom In tool. Users may either click the main map to zoom out or click and drag the mouse to zoom out. Usually a single click is used when zooming out.
	The Zoom Full Extent button will send the map frame back to its default, startup map extent.
	The Zoom Active Layer will tell the main map to zoom as close as possible such that it can show all the active layer's features. Users have the opportunity to change the active layer in the table of contents.
	The Pan tool allows users to move the main map in any direction desired. Users may also use the overview map to quickly pan to another location on the main map.
	The Repository Query tool allows users to pass the name of a feature on the map to the UHOP repository. The Repository returns its results in a new window.
	The Identify Results tool will identify a feature and post its attributes in the text frame below the main map. The Identify Results tool functions on the active layer, which is set in the table of contents.
	The Select by Rectangle tool will select multiple features from the active layer and post the results in the text frame below the map frame. Users may scroll through the list and choose to zoom to a specific feature by clicking on the 'Rec #' field in the table.
	The Clear Selected button will clear the text frame of any results from the active layer. It will also clear any distance segments created using the Measure Tool.

Source: Utah Heavy Oil Program

2.3 ArcIMS® Table of Contents

The table of contents lists the layers shown on the map. Users may toggle this frame between a layer list, which is the default, and a legend list by clicking one of the two buttons just above the layer list as shown in Figure 2-2.

Figure 2-2. Table of contents for map server interface.

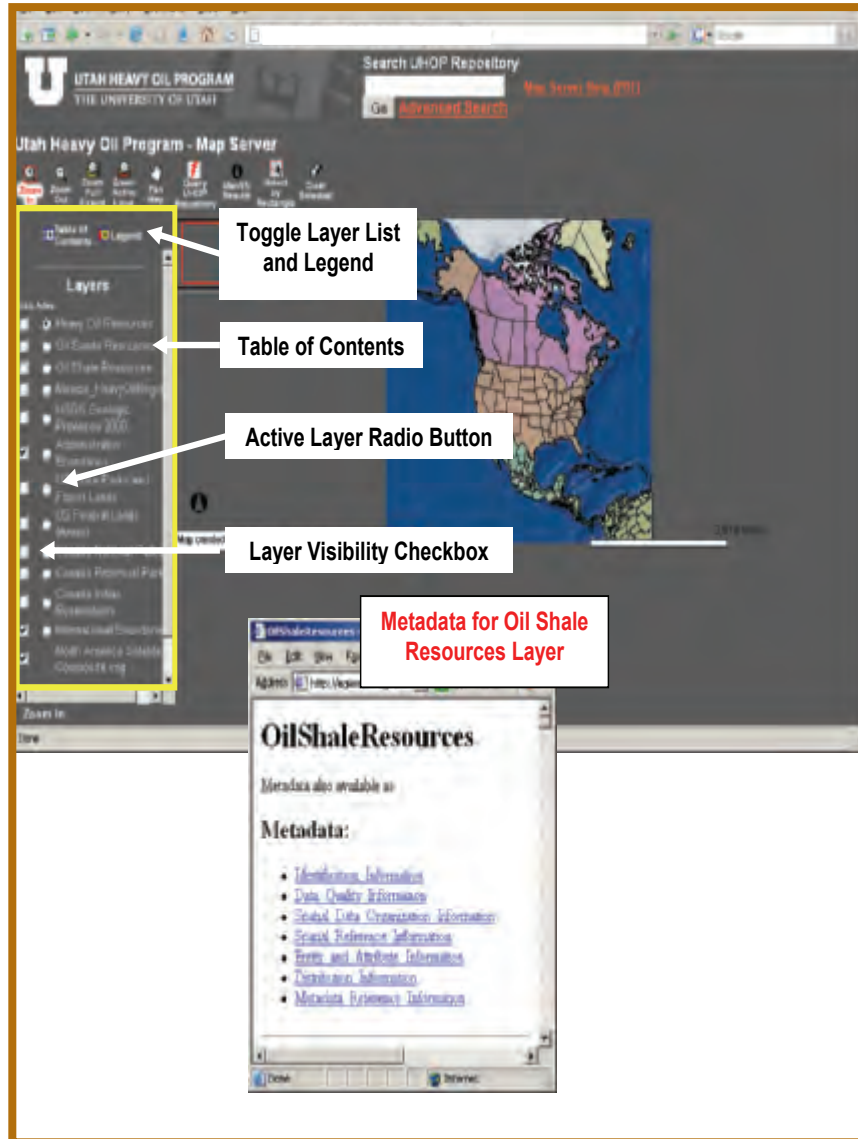

Source: Utah Heavy Oil Program

With the table of contents, the user can set the active layer and control layer visibility, as illustrated in Figure 2-2. When a layer is active, several tools and buttons will only respond to this layer. These tools and buttons include the Identify Results tool, the Select by Rectangle tool, the Find tool, the Zoom Active Layer button, and the Clear Selected button. The layer is currently active if the radio button next to its name is on. If a layer is on, it will have a checkmark in the checkbox next to the active layer radio button and layer name. Layer visibility (layer on or off) is controlled by checking or unchecking the checkbox. When layer visibility is changed, the map will automatically redraw.

The table of contents also contains links to metadata. Metadata, or data about data, describes data sources, projection information and attribute information for each of the GIS layers in the table of contents. To access the metadata from the UHOP map interface, the user clicks the layer name and a window pops up with the layer's metadata.

2.4 Usage Tips

The map server, while useful, can be overwhelming to users who have not been introduced to map server technology. The information in this section provides details on how to use the most important tools and steps for successful interaction with the UHOP map server.

The initial startup of the map server shows a map of North America, a tool bar and a table of contents. The three resource area map layers are turned off by default to avoid clutter on the map. All layers can be turned on or off by using the layer visibility check box next to the layer name.

At startup, one of the map layers is set to active by default. Users can change the active layer by clicking the round radio button next to the layer name. The default active layer is the Heavy Oil Resources layer. When a layer is active, it becomes the focus of attention, and several of the tools and buttons on the toolbar respond only to the active layer including:

1. Zoom Active Layer – zooms to the map extent of the active layer
2. Identify Results – shows tabular information for a specific feature (or features) in the active layer
3. Find – searches the tabular attributes of the active layer based on a text string
4. Select by Rectangle – selects and highlights map features, then posts tabular information from the active layer
5. Clear Selected – clears any tabular and highlighted map features from the active layer.

2.5 Accessing the UHOP Repository through the Map Server Interface

There are three tool choices for accessing the UHOP repository through the map server. They are the Identify Results tool, the Query UHOP Repository tool, and the Select by Rectangle tool.

The Identify Results tool and the Select by Rectangle tool only respond to the active layer, retrieving information from the GIS data and posting the results in the text frame as shown in Figure 2-3. Within the text frame results, the user can link to the UHOP repository by clicking on blue underlined text in the posted tabular results. After the click, a new window will pop up that lists the information found in the repository. In contrast, the Query UHOP Repository tool does not depend on the active layer; it works on all layers. This tool queries the repository directly and, similar to the Identify Results and the Select by Rectangle tools, presents the results in a pop-up style window.

Figure 2-3. Accessing the UHOP repository through posted tabular results.

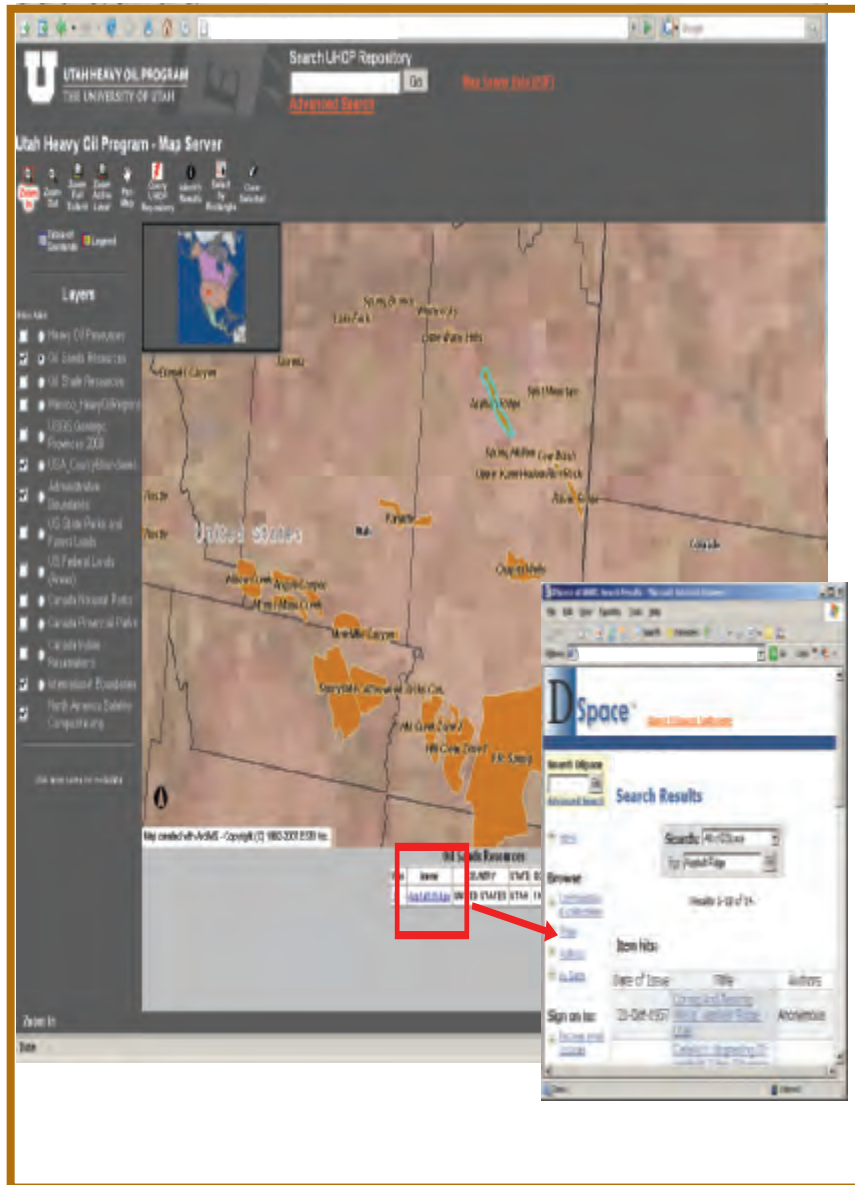

Source: Utah Heavy Oil Program

2.5.1 Using the Identify Results Tool

As the Identify Results tool only responds to the active layer, the user must first decide which map layer he/she would like to see information for and then click the corresponding radio button. A message will display in the text frame indicating the active layer. The next step is to turn the active layer on so that it is visible on the map, keeping in mind that the active layer may already be turned on at startup.

At this point, the user can use the Identify Results tool by clicking the tool in the toolbar, moving the cursor over the map and placing it on top of a feature, and then clicking once. The tabular results will be displayed below the map in the text frame as seen in Figure 2-4.

It is possible that more than one feature is returned for several reasons. First, the map server cannot always decipher the exact feature the user is trying to select. Hence, the map server responds by returning all the features in the area of the user's mouse click. To avoid multiple returns, the user can first use the Zoom In tool. Second, there may be more than one feature at the same location. This scenario happens frequently with point data such as the Heavy Oil Resources map layer, which has multiple features at the same location.

Figure 2-4. Tabular results using the Identify Results tool.

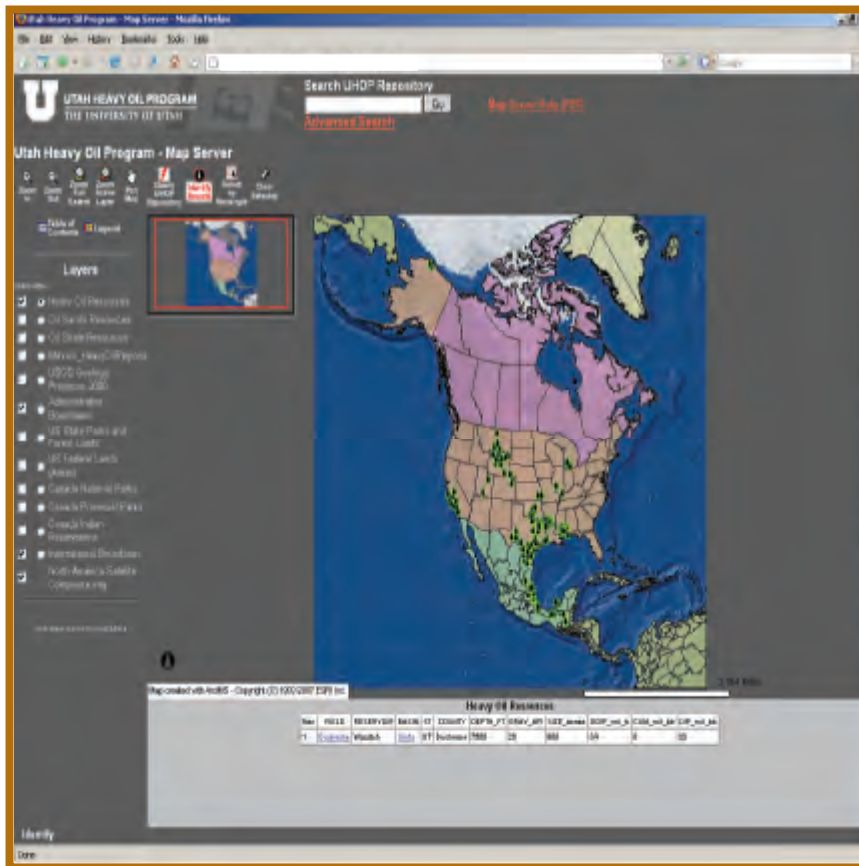

Source: Utah Heavy Oil Program

The tabular results from the Identify Results tool are posted to the text frame. From these results, the user can query the UHOP DSpace repository by clicking on the blue underlined text. Clicking sends the text string to the repository. A new browser window will pop up with query results from the UHOP DSpace repository.

2.5.2 Using the Select by Rectangle Tool

Because the Select by Rectangle tool only responds to the active layer, the user should first determine that the desired layer is active and visible. To use the Select by Rectangle tool, click the tool from the toolbar, move the cursor to the map frame, click and hold down the left mouse button, drag the mouse while holding down the left mouse button, and then release the mouse button. While dragging the mouse, a red box will be drawn indicating the area for selection. After the mouse button is released, the features of the active layer that intersect the red box will be highlighted. Also, the

tabular information representing the selected features will be displayed in a text frame as shown in Figure 2-5. From the returned tabular results, the user may query the UHOP repository by clicking the blue underlined text. As with the Identify Results tool, a new browser window containing results from the query to the UHOP Dspace repository pops up.

Figure 2-5. Tabular results using the Select by Rectangle tool.

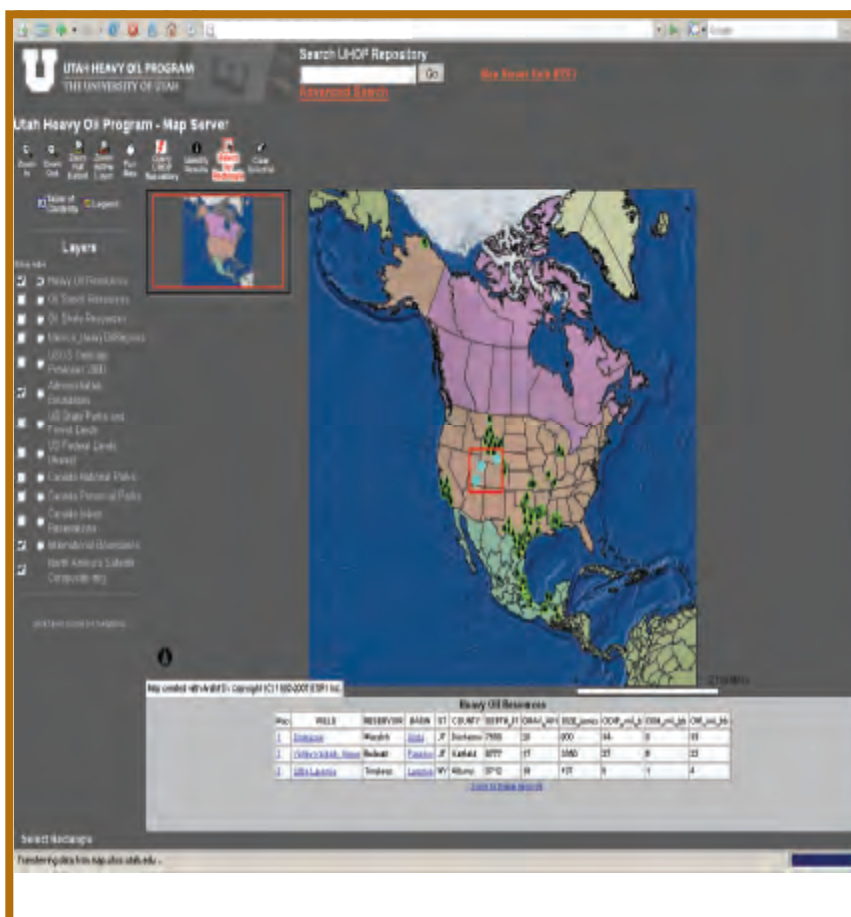

Source: Utah Heavy Oil Program

2.5.3 Using the Query UHOP Repository Tool

The Query UHOP Repository tool is slightly different than the two previous tools. It puts the user on a fast track to the repository by eliminating the intermediate step of displaying tabular results. This tool is NOT limited to the active layer; it works on all layers. Its one disadvantage is that it only works on one feature at a time.

This tool looks for the first available link from the features on the map using a simple priority rule established by the table of contents. The first and top layer in the table of contents has priority over the second layer which has priority over the third, etc. The tool drills down until it finds a valid link (the blue underlined text, which we do not see with this tool). The user needs to have in mind the information he/she would like to retrieve. Zooming in and turning layers off will help focus the attention of the Query UHOP Repository tool.

To use the Query UHOP Repository tool, select the tool from the toolbar, move the cursor to the map frame, place the cursor over the feature of interest and then click once. Immediately, a new window will pop up showing the results from the UHOP Dspace repository; see Figure 2-6. If the feature the user is interested in has no available link, the tool will move to the subsequent layer in the table of contents. If the next layer does have information to pass to Dspace for querying, the results in the pop up window will be from that layer.

Figure 2-6. Results from a UHOP Dspace repository query.

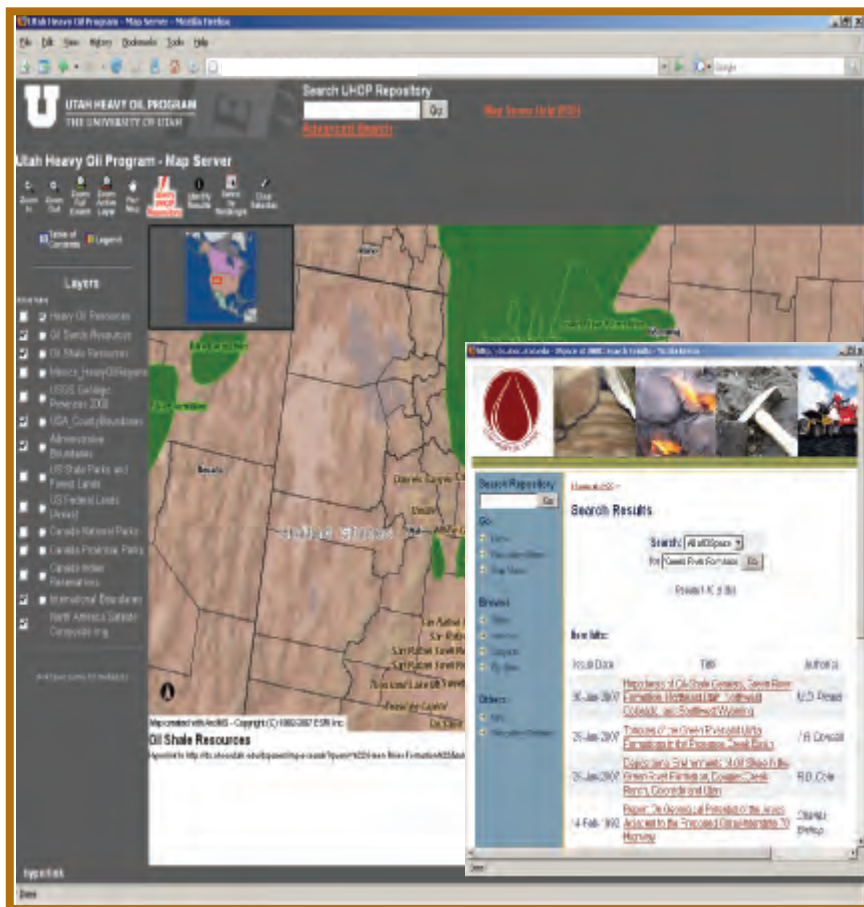

Source: Utah Heavy Oil Program

2.6 Future Work

The UHOP map server interface will evolve, and the map server methods of accessing the repository will undoubtedly change. UHOP hopes users will find the map server a useful secondary or alternative visual means of accessing the UHOP Dspace repository. UHOP will continue to work on the design and functionality of the UHOP map server to further streamline its capabilities.

3

**The North American
Unconventional Oil Resource**

3 The North American Unconventional Oil Resource

Unconventional oil has been divided into four types: heavy oil, extra heavy oil, bitumen and oil shale. Heavy oil, extra heavy oil, and bitumen from oil sands are separated based on American Petroleum Institute (API) gravity and viscosity as seen in Figure 3-1 below [1]. Heavy oil has an API gravity of 10°-22.3° (World Petroleum Congress or WPC) [2] or 10°-20° (United Nations Institute for Training and Research/United Nations Development Programme Information Centre for Heavy Crude and Tar Sands or UNITAR) [2] and viscosity of 100-10,000 cP at 60°F (15.6°C); extra heavy oil has an API gravity below 10° and viscosity of 100-10,000 cP at 60°F (15.6°C); and bitumen has viscosity above 10,000 cP at 60°F (15.6°C). Although the Department of Energy (DOE) uses the WPC definition for heavy oil, most published information for the United States and Canada is based on the UNITAR definition for heavy oil of 10°-20° API gravity. Mexico uses a definition for heavy oil based on an API gravity of 27° or below.

Figure 3-1. Chart of heavy oil (yellow), extra heavy oil (orange) and bitumen (blue) based on viscosity vs. density.

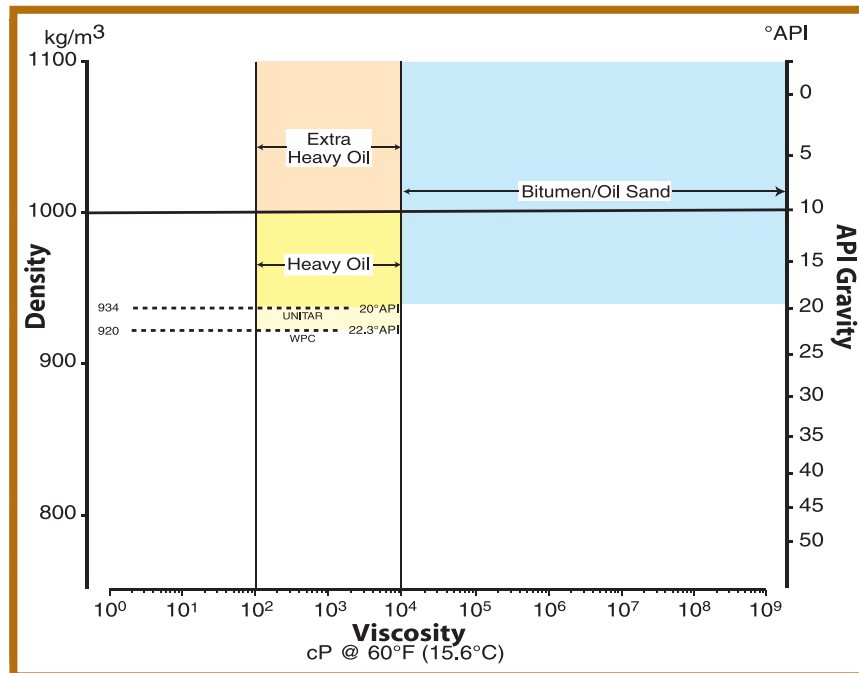

Source: C.D. Cornelius, *Classification of Natural Bitumen: A Physical and Chemical Approach*, 1987

Most heavy oil formed as conventional oil with API gravities of 30°-40°, then migrated and degraded through biological, chemical and physical processes. These products of migration and degradation show a spectrum of API gravities and viscosities as seen in Figure 3-2 [1], from heavy oil (less degraded) through extra heavy oil to natural bitumen (more degraded). More details concerning classification of heavy oil can be found in [3-6].

API gravity = $(141.5/\text{specific gravity at } 60^\circ\text{F}) - 131.5$. Water has an API gravity of 10°. A liquid with API greater than 10° floats on water, less than 10° sinks in water.

Viscosity is a substance's internal resistance to flow. Centipose (cP) is a CGS (centimeter-gram-second system) unit of measurement for viscosity of general usage in the oil industry, equal to the SI-derived (International System of Units) unit of mPa-s.

Figure 3-2. Main distribution of heavy oil to bitumen, and variation during degradation.

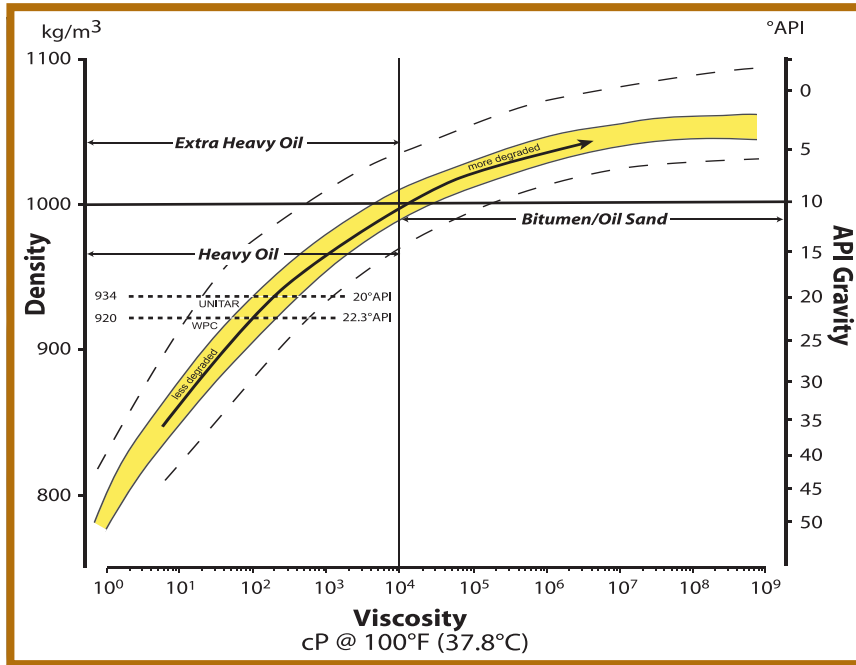

Source: C.D. Cornelius, *Classification of Natural Bitumen: A Physical and Chemical Approach*, 1987

Oil shale, on the other hand, is “a fine-grained sedimentary rock containing organic matter that will yield substantial amounts of oil and combustible gas upon destructive distillation” [7]. These shales are generally immature, and the organic matter has not generated oil or gas that migrated to conventional reservoirs. Instead, the organic matter is preserved as kerogen, a “fossilized, insoluble organic material found in sedimentary rocks . . . which can be converted to petroleum products by distillation” [8].

North America has very large unconventional oil resources. The province of Alberta in Canada has about 1.7 trillion barrels of original oil in place (OOIP) in the form of heavy oil, extra heavy oil and bitumen from oil sands. The province of Saskatchewan has approximately 101 million barrels OOIP of heavy oil. In addition, Canada has at least 15 billion barrels OOIP as kerogen in oil shale. Alaska has up to 30 billion barrels OOIP of heavy oil and bitumen from oil sands. The lower 48 U.S. states have about 79 billion barrels OOIP of heavy oil and 76 billion barrels OOIP of bitumen from oil sands. The U.S. oil shale resource accounts for approximately 2 trillion barrels OOIP in the form of kerogen. Mexico has about 19 billion barrels OOIP of heavy oil.

OOIP refers to “original oil in place” prior to any production.
OIP refers to remaining oil in place after production.

3.1 Heavy Oil Resource

North American heavy oil/extra heavy oil resources occur in the United States, Canada and Mexico as shown in Figure 3-3. The heavy oil occurs in deposits of Cenozoic, Mesozoic and Paleozoic age as illustrated in Figure 3-4. The three deposits with the greatest amount of heavy oil in place in North America are the Lloydminster (Cretaceous) deposits in western Canada containing 101.7 billion barrels OOIP [9], a series of deposits in California with 75.9 billion barrels OOIP, and the large deposits in the Schrader Bluff/West Sak/Ugnu (Cretaceous) area on the North Slope of Alaska with 25,000 [10] to 30,000 [11] million barrels OOIP. U.S. heavy oil deposits are distributed as shown in table 3-1. Of these deposits, 153 are greater than 50 million barrels OOIP [12]. Heavy oil deposits totaling 18.8 million barrels OOIP are located in Mexico [13].

Figure 3-3. Map from the UHOP map server interface showing the location of heavy oil deposits in North America.



Source: Utah Heavy Oil Program

Figure 3-4. Age of heavy oil deposits in the United States and Canada.

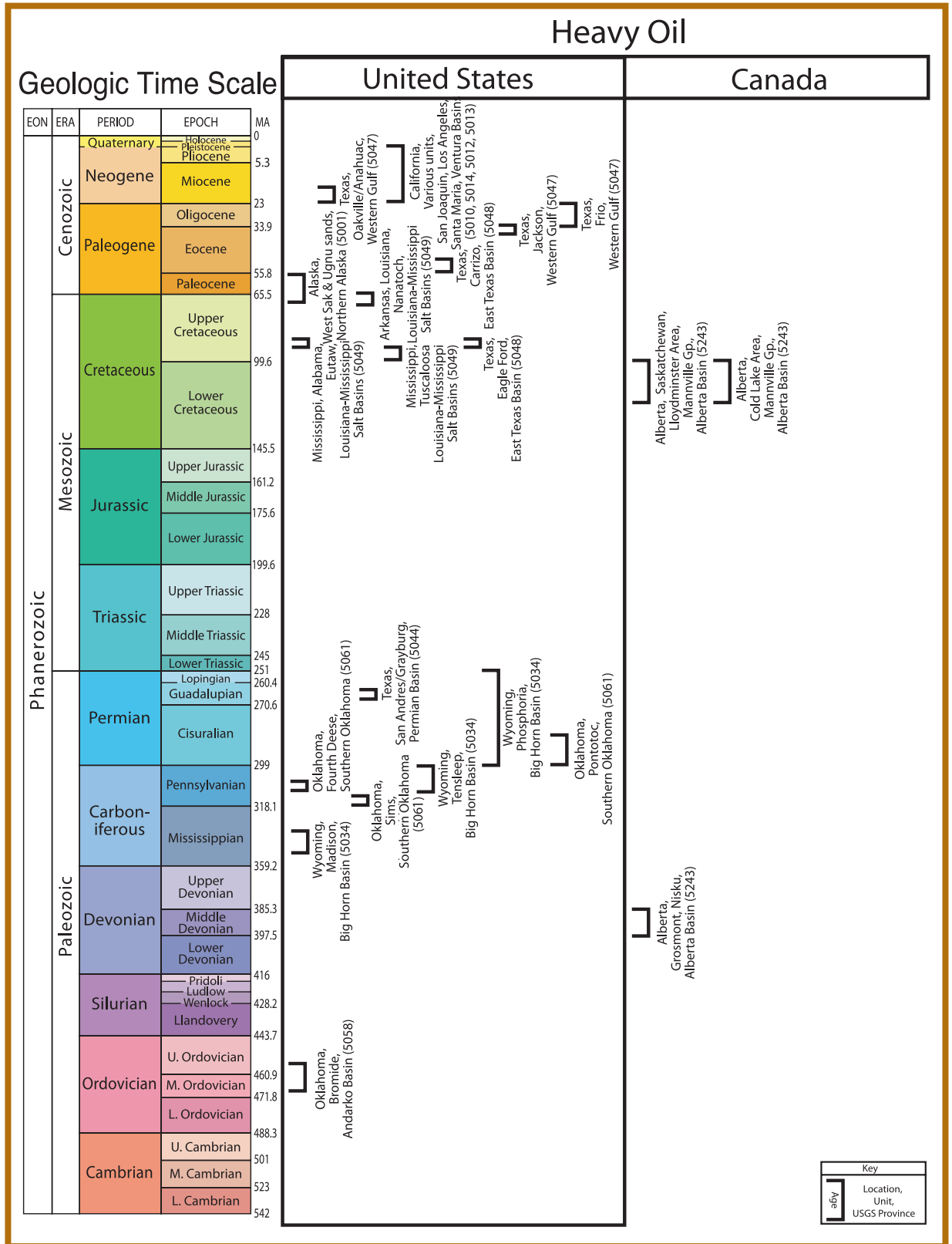

Source: Utah Heavy Oil Program

Table 3-1. U.S. Heavy Oil Database (10°-20°API gravity).

	Original Oil in Place (OOIP), million barrels	Cumulative production, million barrels	Remaining Oil in Place (OIP), million barrels
Alabama	162	23	139
Arkansas	1,381	636	741
California	75,851	8,751	67,100
Colorado	27	9	17
Illinois	4	0	4
Kansas	12	1	11
Louisiana	128	67	60
Michigan	8	0	8
Mississippi	1,188	356	831
Missouri	12	1	11
Montana	66	14	52
Nebraska	2	1	1
Oklahoma	716	130	584
Texas	2,977	349	2,628
Utah	61	5	55
Wyoming	1,637	495	1,124
Total	84,232	10,838	73,394

Source: U.S. Heavy Oil Database Largest 500 Plus Reservoirs, 2004

3.1.1 Canadian Heavy Oil Resource

The unconventional oil deposits (heavy oil to oil sands) in Alberta and Saskatchewan, Canada were generated from Devonian-Jurassic shales in the deeper Alberta Basin that migrated through Upper Devonian aquifers into Lower Cretaceous strata, where they were trapped and subsequently biodegraded [14].

In Alberta, there are enormous resources of heavy oil and bitumen trapped within Paleozoic carbonate units subcropping at relatively shallow depths beneath the better known Athabasca Oil Sands [15]. The Devonian Grosmont, Misku, Debolt and Shunda Formations have an estimated 447.7 billion barrels OOIP of bitumen; the source rock also contains lesser amounts of 5°-9° API gravity heavy oil. Despite the size of the resource, there is only limited production from the Grosmont. In addition, heavy oil has accumulated in Cretaceous Mannville Group sandstone in eastern Alberta and Saskatchewan in the Lloydminster area, with 101.7 billion barrels OOIP of 11°-15° API gravity heavy oil. This resource is related to the lower API gravity, more degraded Athabasca Oil Sands located to the northwest [16] as shown in Figure 3-5 [10].

Subcropping refers to a unit or units occurring below another unit.

Figure 3-5. Location of the Grosmont Platform in Alberta and its relationship to the Athabasca Oil Sands and the Lloydminster heavy oil deposits.

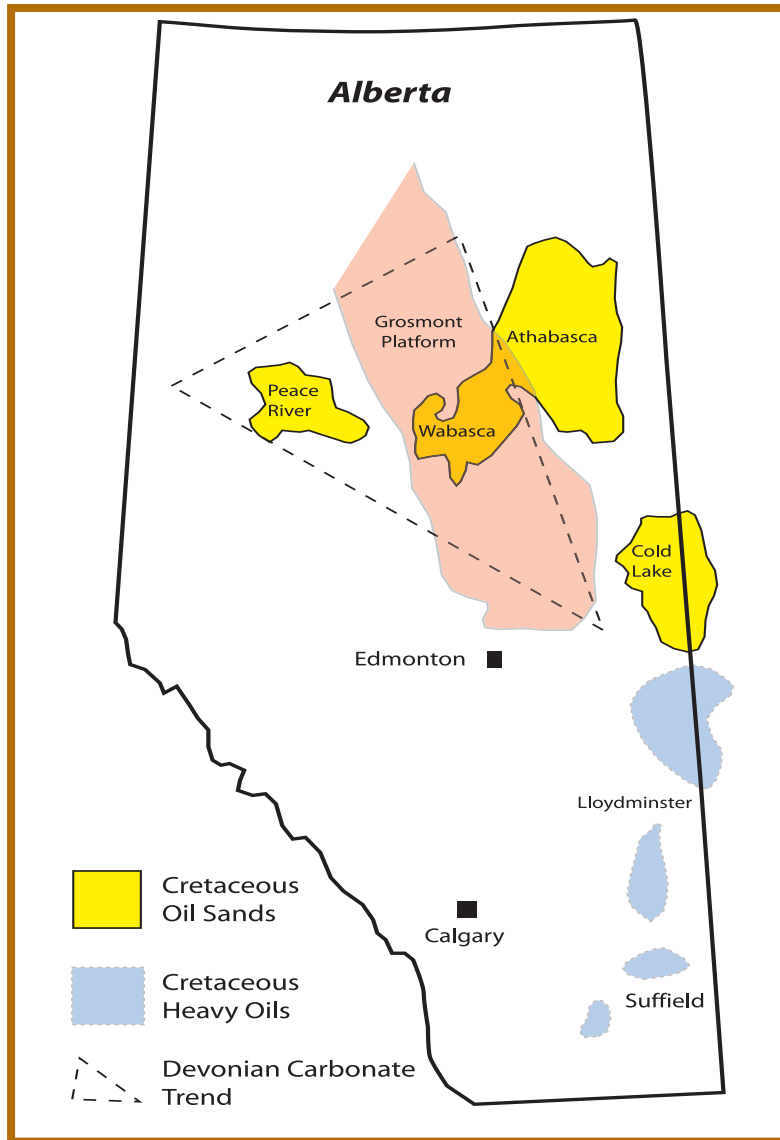

Source: B.E. Buschkuehle and M. Grobe, *Geology of the Upper Devonian Grosmont Carbonate Bitumen Deposit, Northern Alberta, Canada, 2004*

3.1.2 U. S. Heavy Oil Resource

Of the 154 deposits of over 50 million barrels in the U.S. Heavy Oil Database [12], which excludes Alaska, 121 of these deposits are located in California in a series of fields within several basins as seen in Figure 3-6 [17]. Prior to any production, 22 of these 121 deposits contained over one billion barrels OOIP each, although much of the California resource has been developed. One-half of the remaining oil lies in seven fields: Wilmington, Hondo Offshore, Point Penderinas Offshore, Midway-Sunset, Cat Canyon, Santa Maria Valley, and Huntington Beach. Another one-fourth of the remaining oil lies in eight fields: Orcutt, San Ardo, Kern River, Coalinga, South Belridge, McKittrick, Poso Creek, and Mount Poso [18] (also see Table 4-1 in [18]). Because the high viscosity heavy oils require thermal enhanced oil recovery methods

EOR methods include any of several techniques that result in increased production of oil from a subsurface reservoir. EOR methods are discussed in Section 3.1.

(EOR), California is the largest producer of crude oil by EOR in the United States. Production of heavy oil is spread among more than 200 reservoirs [19], most of which are less than 4,000 feet (1219 meters) deep, have high permeabilities (>1,000 mD), and have overall sand thicknesses that exceed 50 feet (15.2 meters).

Figure 3-6. Location of the southwestern California heavy oil basins.

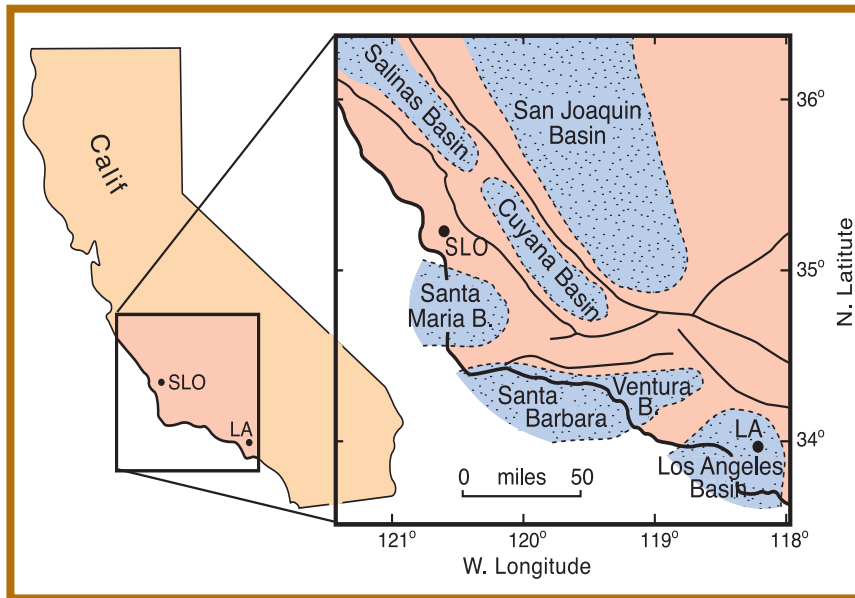

Source: N.F. Petersen and P.J. Hickey, *California Plio-Miocene Oils: Evidence of Early Generation*, 1987

Of the remaining 33 heavy oil deposits over 50 million barrels OOIP in the U.S. Heavy Oil Database [12], 20 deposits containing a total of 3.47 billion barrels OOIP are located along the Gulf of Mexico. Deposits in this region have API gravities of 17°-20°. Viscosities range from 8-160 cP at depths of 8,750-1,528 feet (2667-466 meters) and reservoir temperatures of 229°-100°F (109°-38°C) to viscosities of 530-1,000 cP at depths of 490-350 feet (149-107 meters) and reservoir temperatures of 80°-75°F (26.7°-23.9°C). The final 13 deposits include nine deposits with a combined total of just over one billion barrels OOIP located in the Bighorn Basin of Wyoming, three deposits totaling 325 million barrels OOIP located in the Ardmore Basin in Oklahoma, and a deposit with 140 million barrels OOIP in the Anadarko Basin in Oklahoma.

In Alaska, the shallow Upper Cretaceous-Paleocene Schrader Bluff, West Sak and Ugnu heavy oil reservoirs overlie the main conventional oil reservoirs at the Kuparuk River, Milne Point, and Prudhoe Bay fields as seen in the map in Figure 3-7 [20,21]. With up to 30 billion barrels OOIP, these deposits are larger than the North Slope's Prudhoe Bay [21]. The deposits are at depths between 2,000-4,700 feet (610-1,433 meters). The deeper Schrader Bluff Formation and West Sak Sands have 17°-21° API gravities and viscosities of 20-3,000 cP, while the shallower Ugnu Sands have 7°-12° API gravities and viscosities of 2000 to over 10,000 cP [4,22]. The viscosity range in the Ungu Sands indicates that some of the resource is in the form of bitumen, although detailed information related to the quantity of the heavy oil versus bitumen resource is unavailable. In 2003, the Schrader Bluff Formation in the Milne Point Unit produced

Permeability, which is a measurement of a rock's ability to transmit fluids, is typically measured in darcies (D) or millidarcies (mD). It is not an SI unit but is widely used in petroleum engineering and geology.

Most of the heavy oil deposits in California are in these basins.

19,000 BOPD in the form of heavy oil, and the West Sak Formation in the Kuparuk River Unit produced 7,800 BOPD in the form of heavy oil [11].

BOPD refers to barrels of oil per day.

Figure 3-7. Distribution of heavy oil overlying the Kuparuk River, Milne Point, and Prudhoe Bay fields on the North Slope of Alaska.

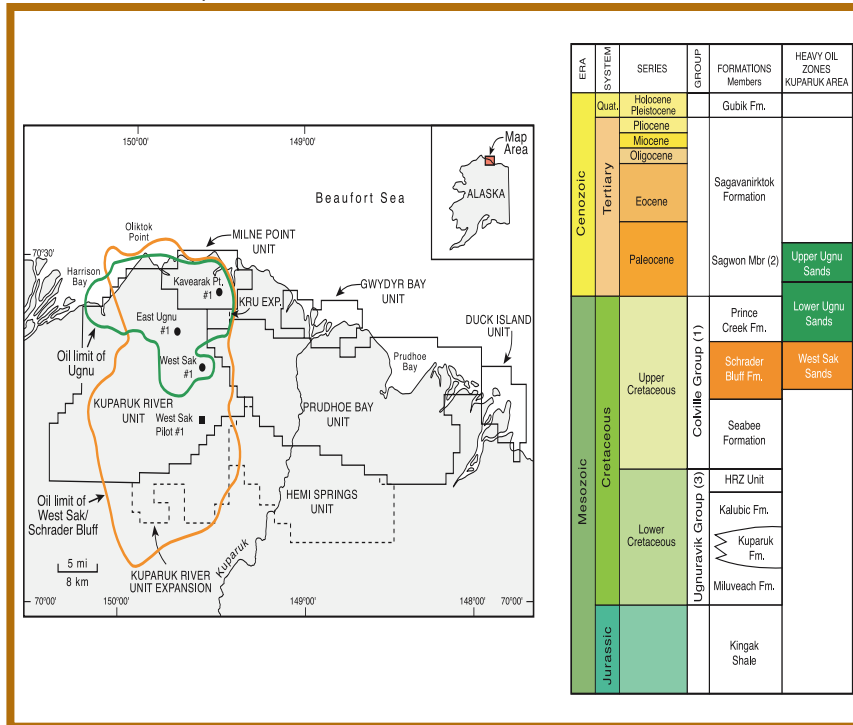

Source: M.R. Werner, *Tertiary and Upper Cretaceous Heavy-Oil Sands: Kuparuk River Unit Area, Alaskan North Slope*, 1987; M.D. Croft et al., *Unlocking the Potential of the Schrader Bluff Formation, North Slope Alaska*, 1999

3.1.3 Mexican and Central American Heavy Oil Resource

Mexico has a series of fields containing medium and heavy oil. The heavy oil resource included in this report is based on API gravities of 10°-27°, as listed by Pemex, the Mexican national oil company. Nevertheless, viscosities in these heavy oil deposits are low enough that the oils are produced using conventional methods. Heavy oil accounts for about 57% of the total remaining proven, probable and possible oil in place in Mexico as seen in Table 3-2 [13].

Table 3-2. Table of the remaining proven, probable and possible hydrocarbon reserves in Mexico as of January 1, 2006.

Region		Oil (million barrels)			Gas (billion cubic feet)	
		Heavy (10°-27°)	Light (27°-38°)	"Superlight" (>38°)	Associated	Not Associated
Marina Noreste	Cantarell	7,836.0	78.9	0.0	3954.1	57.8
Marina Noreste	Ku-Maloob-Zaap	5,651.5	0.0	0.0	2,176.6	0
Marina Noreste	Total	13,487.5	78.9	0.0	6,130.7	57.8
Marina Suroeste	Abkatún-Pol-Chuc	261.6	795.6	65.2	1,367.9	286.2
Marina Suroeste	Litoral de Tabasco	406.0	742.9	501.9	1,593.7	2423.2
Marina Suroeste	Total	667.6	1,538.4	567.1	2,961.6	2709.3
Norte	Burgos	0.0	0.0	1.3	12.3	4948.3
Norte	Poza Rica-Altamira	4,317.5	7,037.2	1,509.3	31,581.7	1089
Norte	Veracruz	8.9	3.0	0.0	132.7	1291.3
Norte	Total	4,326.4	7,040.3	1,510.6	31,726.6	7328.5
Sur	Bellota-Jujo	16.6	937.6	223.4	2,676.0	117.1
Sur	Cinco Presidentes	4.5	364.6	4.5	376.5	89.9
Sur	Macuspana	0.0	25.7	66.8	27.2	1654
Sur	Muspac	16.0	192.5	80.1	644.3	1941.5
Sur	Samaria-Luna	268.1	1,345.2	330.5	3,640.0	273.8
Sur	Total	305.2	2,865.7	705.3	7,364.1	4076.2
Total country		18,786.7	11,523.3	2,783.0	48,183.0	14,171.8

Source: Pemex, *Las Reservas de Hidrocarburos de México: Evaluación al 1 de enero de 2006*

About 72% of the heavy oil is in the Marina Noreste region of Mexico, illustrated in Figures 3-8 and 3-9 [13]. Another 23% of the heavy oil is in the Altamira-Poza Rica area of the Norte region, illustrated in Figures 3-8 and 3-10 [13]. The remaining 5% of the heavy oil in Mexico is dispersed in the other regions and areas.

Figure 3-8. Map of the exploration and production regions (Región) of Mexico.



Source: Pemex, Las Reservas de Hidrocarburos de México: Evaluación al 1 de enero de 2006

Figure 3-9. Map of the areas (Activo Integral) in the Marina Noreste region in Mexico.

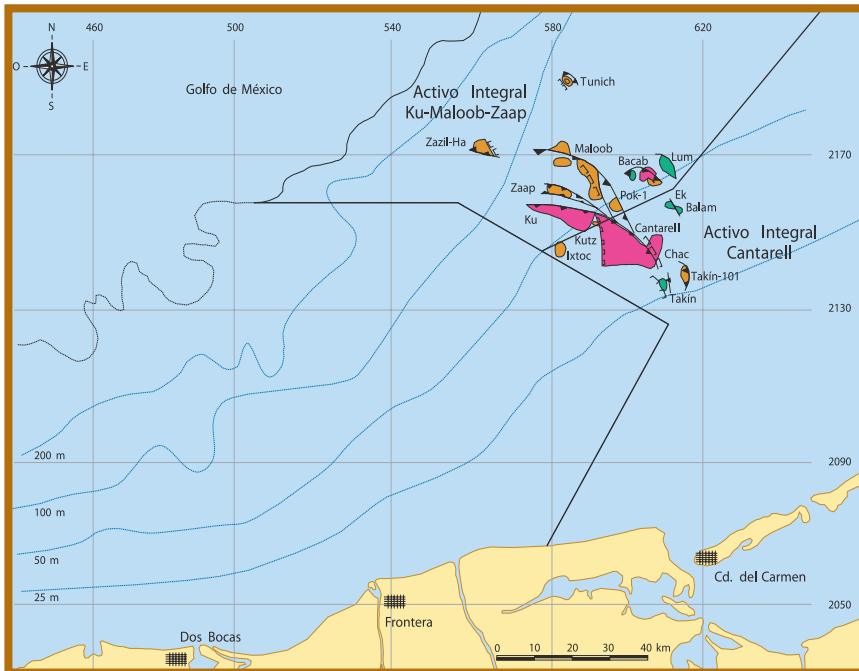

Source: Pemex, Las Reservas de Hidrocarburos de México: Evaluación al 1 de enero de 2006

Figure 3-10. Map of the areas (Activo Integral) in the Norte region in Mexico.



Source: Pemex, *Las Reservas de Hidrocarburos de México: Evaluación al 1 de enero de 2006*

In the Marina Noreste region, the primary reservoirs are of Upper Cretaceous to Lower Paleocene breccias derived from the Yucatan shelf and/or the Chicxulub Crater. API gravities for these breccia range from 19°-36°, but, as noted in Table 3-2, heavy oil accounts for the majority of the production (see also [23]). Depths for the reservoirs range from 17,060-7,381 feet (5,200-2,250 meters), and reservoir temperatures range from 297°-176°F (147°-80°C).

Most of the heavy oil production in the Altamira-Poza Rica area of the Norte region is from the Lower Cretaceous Tamaulipas Limestone and the El Arba Limestone. Unfortunately, it is difficult to find information on these heavy oil deposits. Much of the available information is based on exploration conducted in the early part of the 20th century [24-26]. One source mentions that most of the old production used stripper wells, where production was restricted to allow the oil to move towards the wells without water problems [24]. Greater detail on these heavy oils will likely require data collection in Mexico.

Finally, a few heavy oil deposits also occur in Guatemala, with API gravities of 14.5°-19° [27]. The largest deposit is the Xan deposit, with about 100 million barrels OOIP [28].

A breccia is a coarse-grained clastic rock, composed of angular broken rock fragments held together by a mineral cement or in a fine-grained matrix [8].

A stripper well is an oil well whose production is less than ten barrels a day.

3.2 Oil Sands Resource

North America oil sands resources occur primarily in Canada and the United States as seen in Figure 3-11. Figure 3-12 shows that oil sands occur in deposits of Cenozoic, Mesozoic and Paleozoic age.

Figure 3-11. Map from the UHOP map server interface showing the location of oil sands in North America.



Source: Utah Heavy Oil Program

Figure 3-12. Age of oil sands deposits in the United States and Canada.

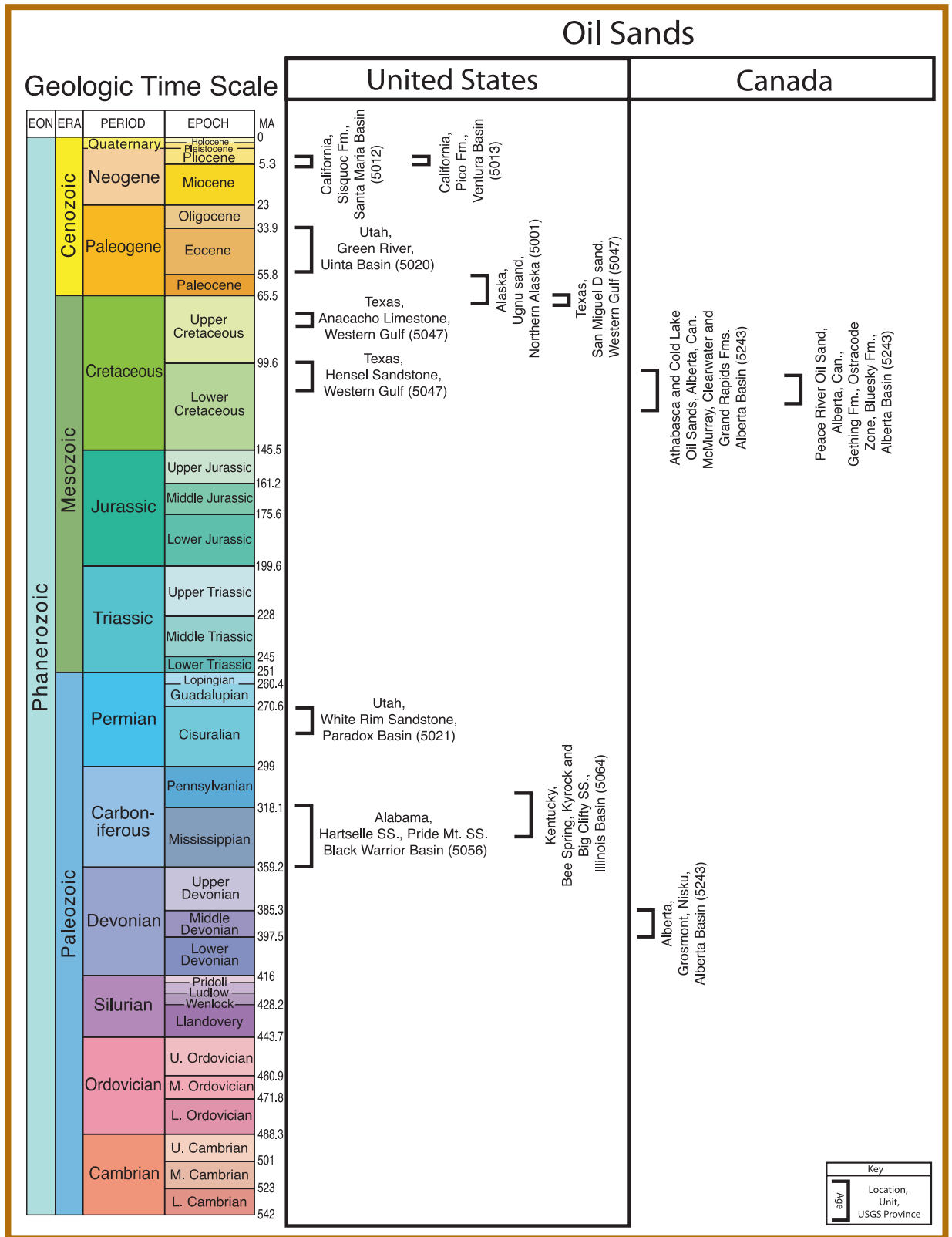

Source: Utah Heavy Oil Program

3.2.1 Canadian Oil Sands Resource

Canada has one of the greatest oil reserves in the world in the form of oil sands, with almost 1.7 trillion barrels OOIP in the form of bitumen in western Canada as noted in Table 3-3 [29]. The 1699 billion barrels OOIP includes the 447.7 billion barrels of oil from bitumen in carbonates [30] mentioned in the heavy oil section above. Of the total reserves, 174 billion barrels are proven reserves that can be recovered using current technology. The three dominant oil sands deposits, listed in Table 3-4 [31], are the Athabasca, Peace River and Cold Lake deposits covering about 57,500 square miles (149,000 square kilometers).

Table 3-3. Original in-place crude oil and oil sands and remaining proven reserves for Alberta.

	Conventional Oil (billion barrels)	Oil Sands (billion barrels)
Original in-place oil or bitumen	62.9	1699
Remaining Established Recoverable	1.6	174
Remaining Ultimate Potential	19.7	315

Source: Alberta Energy and Utilities Board, *Oil Reserves and Production, Alberta, 2006*

Table 3-4. Oil sands resource in the Athabasca, Peace River and Cold Lake deposits.

Oil Sands Deposit	Original in place oil or bitumen (barrels)	Land area (square kilometers)
Athabasca (in situ and surface mineable)	1.37 trillion (110 billion is surface mineable)	102,610 (2,800 is surface mineable)
Cold Lake	201 billion	29,560
Peace River	129 billion	17,250
Total Oil Sands	1.7 trillion	149,420

Source: D. Woynilowicz et al., *Oil Sands Fever: The Environmental Implications of Canada's Oil Sands Rush, 2005*

These major oil sands deposits consist of a mixture of bitumen, silica sand, clay minerals, and water. The hydrocarbon accumulated in the Lower Cretaceous Mannville Group sands (Athabasca and Cold Lake deposits) or in the Aptian-Albian Gething Formation, Ostracode Zone, and Bluesky Formation (Peace River deposit) [32]. These areas acted as a regional hydrocarbon 'drain' for subcropping formations [33]. Additionally, the sands were and are major aquifers for incoming fresh meteoric water, which allowed bacteria to biodegrade the hydrocarbons to heavy oil and oil sands. These sands hold 8.5° to 15° API gravity bitumen with viscosity up to 1,000,000 cP at reservoir temperatures of 59°F (15°C) [3,4].

3.2.2 U.S. Oil Sands Resource

High oil prices and the economic success of production from Canadian oil sands have contributed to renewed interest in oil sands development in the western United States. The U.S. oil sands resource is estimated at 54 billion barrels OOIP in the form of bitumen; 22 billion barrels are considered to be a measured resource with 32 billion

Remaining Established Recoverable in-place oil or bitumen can be produced using current technology minus production to date.

Remaining Ultimate Potential in-place oil or bitumen can be produced using unproven techniques that will rely on technology breakthroughs, minus production to date.

Both heavy oil and oil sands are present in these deposits.

Meteoric water is groundwater which originates from precipitation.

barrels considered speculative. The distribution of oil sands resources in the United States is shown in Table 3-5 [34].

Table 3-5. Oil sands resource in the United States.

	OOIP, proven, (million barrels)	OOIP, speculative, (million barrels)	OOIP, total, (million barrels)
Alabama	1,760	4,600	6,360
Alaska	0	19,000	19,000
California	2,541	2,799	5,340
Colorado	-	-	-
Kansas	120	760	880
Kentucky	1,740	1,680	3,420
Missouri	100	1,970	2,070
Montana	-	-	-
New Mexico	130	220	350
Oklahoma	11	802	813
Texas	4,420	1,021	5,441
Utah	11,597	20,737	32,334
Wyoming	120	70	190
Total	22,539	53,659	76,198

Source: T.B. Reid and R. Mikels, *U.S. Tar Sands Deposits*, 1993

The largest oil sands deposits in the United States are in Utah. Major Utah reservoirs are listed in Table 3-6, along with proven (measured), probable and possible resources [35,36]. Additional resource characterization is necessary to resolve the differences in Utah resource estimates seen in Tables 3-5 and 3-6.

Table 3-6. Table of the Utah oil sands resource in-place.

Region	Deposit	Proven (million barrels)	Probable (million barrels)	Possible (million barrels)	Total (million barrels)
Uinta Basin	Asphalt Ridge	435	438	175	1,048
	Asphalt Ridge, NW	2	3	95-120	100-125
	Hill Creek	350	480	330	1,160
	PR Spring	2,500	1,200	550-1,100	4,250
	Sunnyside	1,800	2,200	1,200-1,850	5,200-5,850
	Whiterocks	50	40	35-50	125-140
Circle Cliffs	Circle Cliffs	707	430	170	1,307
San Rafael Swell	San Rafael Swell	35	55	355-455	445-545
Paradox Basin	Tar Sand Triangle	2,500	3,600	3,400-7,900	9,500-14,000
	30 other minor deposits	60	66	119-212	250-343
Total		8,439	8,512	6,429-12,362	23,385-28,768

Source: A. G. Oblad et al., *Tar Sand Research and Development at the University of Utah*, 1987; H. R. Ritzma, *Oil-Impregnated Rock Deposits of Utah*, 1979

Most of the reserves are associated with the Uinta and Paradox Basins shown in Figure 3-14 [37]. In the early 1980s, seven Special Tar Sand Areas (STSAs) in the Uinta Basin were designated by the United States Geological Survey (USGS) Conservation Division Classification Committee under direction from Congress pursuant to the Combined Hydrocarbon Leasing Act of 1981 [38]. The Uinta Basin holds the Pariette, Sunnyside, Argyle Canyon - Willow Creek, Asphalt Ridge - Whiterocks, Hill Creek, P.R. Spring, and Raven Ridge - Rim Rock STSAs. Several other tar sands deposits are present in southern Utah (see Figure 7-2). In 1995, the Bureau of Land Management (BLM) issued leases on eight parcels covering 13,852 acres (56 square kilometers) of STSAs in the Sunnyside and P.R. Spring deposits, but no significant oil sands development took place under any of the leases (see Section 7.1.1).

Figure 3-13. Location of oil sands in Utah.

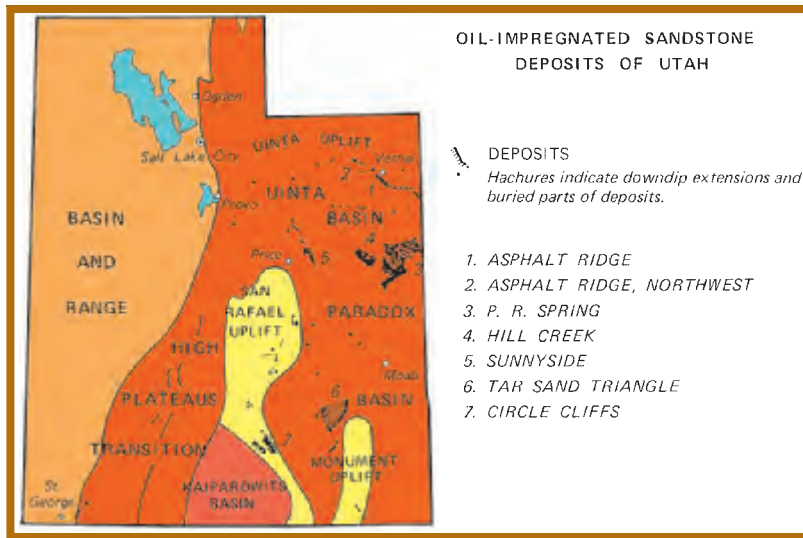

Source: J. A. Campbell and H. R. Ritzma, *Geology and Petroleum Resources of the Major Oil-Impregnated Sandstone Deposits of Utah*, 1981

Of the remaining oil sands deposits in the United States, the bitumen from oil sands in Alaska was briefly discussed in the heavy oil section. Information related to oil sands deposits in California and Texas is very sparse as these deposits are associated with the heavy oil in their respective areas. As such, these deposits are not discussed here. The approximate location of these deposits can be seen in Figure 3-11.

Alabama is estimated to have 1.8 billion barrels of measured and 4.6 billion barrels of speculative OOIP in the form of bitumen. This resource occurs in one major and two minor deposits. The major deposit is in northwestern Alabama in the northeastern Mississippian in the Hartselle sandstone. Resource calculations indicate that the Hartselle contains 1.76 billion barrels of measured and 4.5 billion barrels of speculative resource in-place underlying 2 million acres [39].

Western Kentucky is estimated to have 1.7 billion barrels of measured and 1.7 billion barrels of speculative OOIP in the form of bitumen [39]. The oil-impregnated sands occur in the Big Clifty, Hardinsburg and Tar Springs sandstones, all of Mississippian age, and the Kyrock and Bee Spring sandstones of the Lower Pennsylvanian Caseyville Formation.

Oil sand deposits are also present in the tri-state area of southeastern Kansas, southeastern Missouri, and northeastern Oklahoma, and occur most frequently in rocks of the Cherokee Group of Middle Pennsylvanian Age [40]. The main reservoirs are the Bluejacket sandstone and the Warner sandstone.

3.2.3 Mexican and Central American Oil Sands Resource

Asphalt, with similar properties to bitumen from oil sands, is listed in the Tampico Basin area of Mexico [27], but no details have been found. Meyer and Medaisko [27] also list a single deposit each in Honduras and Nicaragua, again with no details.

3.3 Oil Shale Resource

North American oil shale resources occur in Canada and the United States as seen in Figure 3-14. Figure 3-15 shows that oil shale occurs in deposits of Cenozoic, Mesozoic and Paleozoic age. Table 3-7 lists the oil shales of Canada and of the United States [7]. In the table, “?” denotes that information about the specific resource is unclear; blank table cells indicate that there is no available data.

Figure 3-14. Map from the UHOP map server interface showing the location of oil shale deposits in North America.



Source: Utah Heavy Oil Program

Figure 3-15. Age of oil shale deposits in the United States and Canada.

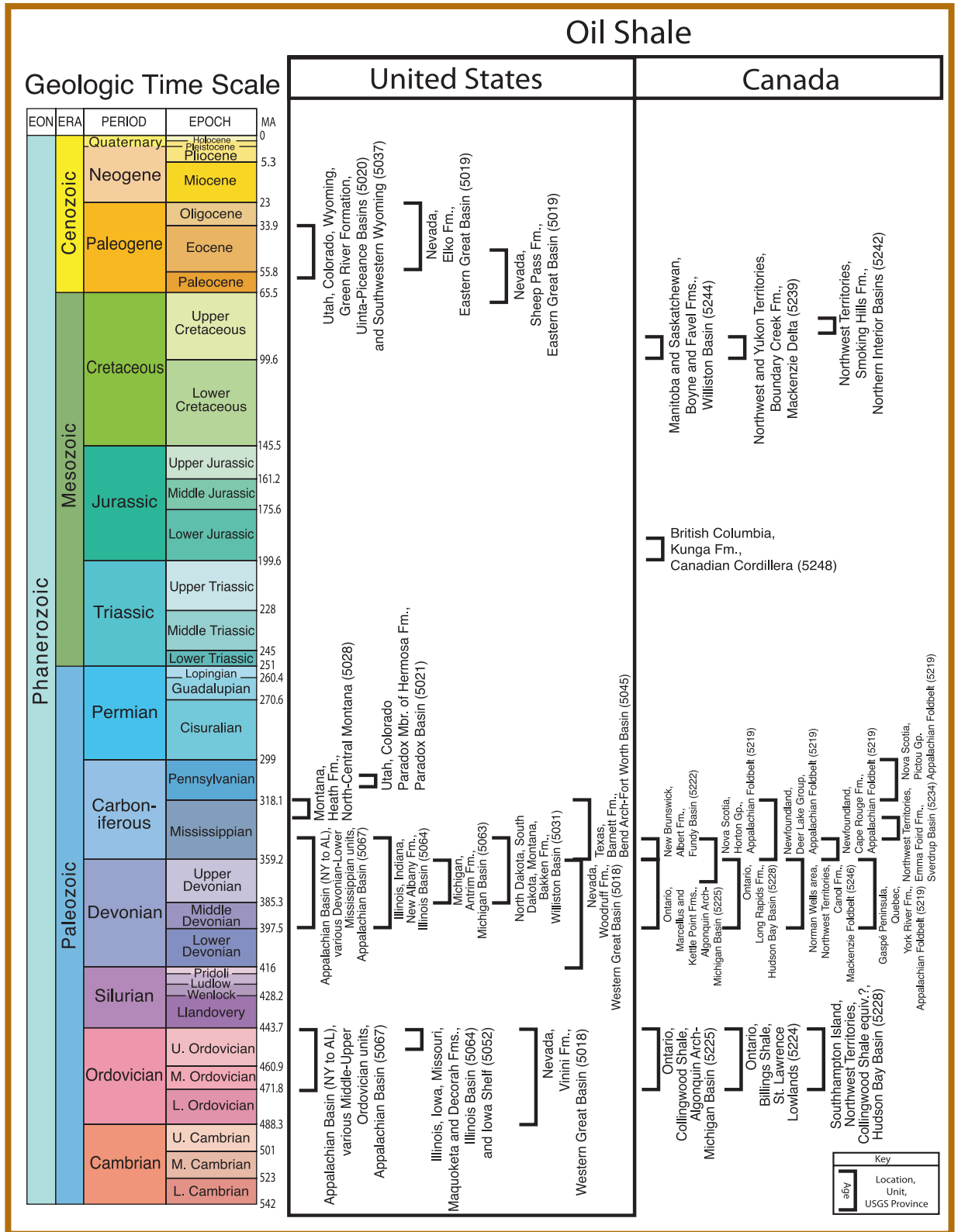

Source: Utah Heavy Oil Program

Table 3-7. Characterization of North American oil shale deposits.

Deposit	State or Province	Geologic unit	Age	Oil shale type	Thickness, meters	Grade, liters/ton	In-place shale oil resources, x 10 ⁶ barrels	In-place shale oil resources, x 10 ⁶ tons	Date of estimation	Source (see Dyni, 2003)
Queen Charlotte Islands	British Columbia	Kunga Formation	Jurassic	Marinite	<35	<35				
Cariboo district	British Columbia	?	Lower Jurassic	Marinite		Minor oil yields				
Manitoba Escarpment	Manitoba and Saskatchewan	Boyne and Favel Formations	Cretaceous	Marinite?	40 & 30, respectively	20-60	1,250	191	1981	Macaulay (1981, 1984, 1986)
Moncton sub-basin	New Brunswick	Albert Formation	Carboniferous	Lamosite	15-360	35-95	286	40.4	1988	Ball & Macauley (1988)
Deer Lake, Humber Valley	Newfoundland	Deer Lake Group	Carboniferous	Lamosite	<2	15-146			1984	Hyde (1984)
Conche area	Newfoundland	Cape Rouge Formation	Lower Mississippian	Torbanite?		Unknown				
Mackenzie Delta	Northwest and Yukon Territories	Boundary Creek Formation	Upper Cretaceous	Marinite		Unknown				
Southampton Island	Northwest Territories	May be equivalent to Collingwood Shale	Ordovician	Marinite		Unknown				
Norman Wells area	Northwest Territories	Canol Formation	Devonian	Marinite	<100	Unknown				
Anderson Plain	Northwest Territories	Smoking Hills Formation	Upper Cretaceous	Marinite	30	>40				
Grinnell Peninsula, Devon Island, Canadian Arctic	Northwest Territories	Emma Fiord Formation	Cretaceous Early	Lacustrine: lamosite?	>100	11-406				
Antigonish Basin	Nova Scotia	Horton Group	Carboniferous	Lamosite	60-125	<59	531	76	1990	Smith & Naylor (1990)
Stellarton Basin, Pictou County	Nova Scotia	Pictou Group	Pennsylvanian	Torbanite and lamosite	< 5-35 (in 60 beds)	25-140	1,174	168	1989	Smith & others (1989)
Manitoulin-Collingwood trend	Ontario	Collingwood Shale	Ordovician	Marinite	2-6	<40	12,000	1,717	1986	Macaulay (1986)
Ottawa area	Ontario	Billings Shale	Ordovician	Marinite		Unknown				
North shore of Lake Erie, Elgin and Norfolk Counties	Ontario	Marcellus Formation	Devonian	Marinite		Probably minor				
Moose River Basin, Ontario	Ontario	Long Rapids Formation	Devonian	Marinite		Unknown				
Windsor-Sarnia area	Ontario, southwest	Kettle Point Formation	Devonian	Marinite	10	41			1986	Macaulay (1986)
Gasp Peninsula	Quebec	York River Formation	Devonian	Marinite		Unknown				
Eastern Devonian shale	NY, OH, PA, KY, TN	Various	Devonian				189,000	27,000	1980	Matthews & others (1980)
Green River Fm.	WY, CO, UT	Green River Fm.	Eocene				1,499,000	215,000	1999	Dyni (2003)
Phosphoria Fm.	ID, MT, WY, UT	Phosphoria Fm.	Permian				250,000	35,775	1980	Smith (1980)
Heath Fm.	MT	Heath Fm.	Mississippian				180,000	25,758	1980	Smith (1980)
Elko Fm.	NV	Elko Fm.	Eocene-Oligocene				228	33	1958	
Illinois Basin	IL, IN, KY	New Albany Fm.	Devonian							

Source: J. R. Dyni, *Geology and Resources of Some World Oil-Shale Deposits*, 2003

3.3.1 Canadian Oil Shale Resource

The Devonian-Lower Mississippian shales in the eastern United States that extend north into Ontario and Quebec (Table 3-7) have a high volume of organic-rich shale. A similar setting also occurs in the Ordovician in Canada (Table 3-7), but the total volume of organic-rich shale is lower. Flooding of the continental margin also occurred in Arctic Canada in the Devonian and Ordovician, and organic-rich shales of these ages are present in the Northwest Territories (Table 3-7).

In eastern Canada, a series of rift basins developed in Nova Scotia, New Brunswick, and Newfoundland in the Carboniferous. In several of these basins, intervals of organic-rich lacustrine shales developed [7,41], although the total volume and the potential of the shales is probably limited (Table 3-7).

Finally, there are a series of oil shales in Canada listed in Table 3-7 which lack estimates for the size of the resource. Details on these units can be found in [7] and [41].

Lacustrine means a deposit formed in the sedimentary environment of a lake.

3.3.2 U.S. Oil Shale Resource

The Eocene age deposits of the Green River Formation in Colorado, Utah and Wyoming are volumetrically the largest oil shale resource in North America. A close-up view of this region is shown in Figure 3-16. Resource estimates for the lacustrine sediments of the Green River Formation are 1.5 trillion to 1.8 trillion barrels OOIP in shale exceeding a grade of 15 gallons per ton [7].

One barrel of oil contains 42 gallons.

Figure 3-16. Location of the Green River Formation in Wyoming, Utah and Colorado.

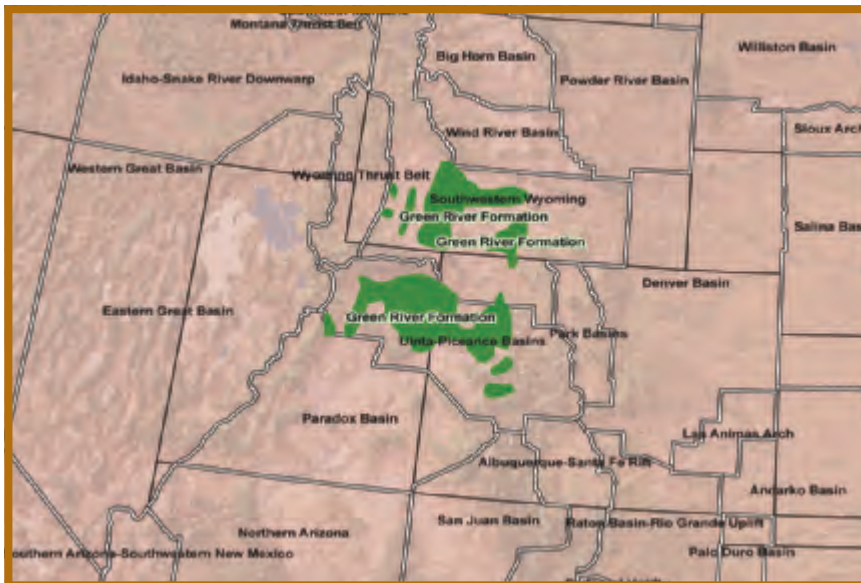

Source: Utah Heavy Oil Program

Other resources in the western United States include oil shales deposited in the Mississippian (Heath Formation) and Permian (Phosphoria Formation) in Montana and Wyoming. The estimated size of the resource in these two units is, respectively, 180 and 250 billion barrels OOIP in the form of kerogen [7]. Lacustrine oil shales were also deposited in Nevada in the Eocene-Oligocene. Relatively high yields are listed in the Elko Formation [42], but the organic-rich intervals are relatively thin, resulting in a low total resource volume.

Of the other U.S. oil shales, Devonian-Lower Mississippian shales in the eastern United States have a high volume of organic-rich shale, but they generally show lower total organic content than the Green River Formation. These shales may contain 189 billion barrels OOIP in the form of kerogen [7].

3.3.3 Mexican and Central American Oil Shale Resource

No oil shales in Mexico or Central America have been found in the literature.

3.4 New Technology Impacts

Several advances in technology since the mid-1980's could have significant positive impacts on the development of heavy oil/extra heavy oil, oil sands and oil shale. In resource definition, the major impacts are likely in two categories. One is the advancement in sequence stratigraphic conceptual models for characterizing reservoir continuity. Sequence stratigraphy "attempts to link prehistoric relative sea-level changes to sedimentary deposits" by the mapping of strata based on the identification of time lines [43]. Sequence stratigraphy is replacing the lithostratigraphic approach, which emphasizes observable rock characteristics rather than time significance. With sequence stratigraphy, geologists can increase their knowledge of regional resource variability and improve predictions of the depositional components of the resource. Stratigraphic models will also aid in the prediction of chemical variability in the rock such as carbonate content. This information is critical as levels of CO₂ generated can be better predicted in advance and compensating mitigation strategies can be developed.

Sequence refers to cyclic sedimentary deposits, while stratigraphy refers to the study of rock layers and layering [43].

The second major technological impact is the application of improved seismic acquisition for imaging reservoirs. The generation and recording of seismic data requires a source and a receiver/recorder. Vibrations from a source "pass through strata with different seismic responses and filtering effects," return to the surface, and are recorded as seismic data [44]. By optimizing acquisition for local conditions, subsurface reservoirs can be identified, characterized, and monitored, even during the production phase.

3.5 References

- [1] Cornelius, C.D. Classification of Natural Bitumen: A Physical and Chemical Approach. In *Exploration for Heavy Crude Oil and Natural Bitumen*, Meyer, R.F., Ed.; Studies in Geology, Vol. 25; AAPG: Tulsa, OK, 1987; pp 165-174.
- [2] Martínez, A.R.; Ion, D.C.; DeSorcy, G.J.; Dekker, H.; Smith, S. Classification and Nomenclature Systems for Petroleum and Petroleum Reserves, 1987 Report. In *Proceedings of the Twelfth World Petroleum Congress*; John Wiley & Sons Limited; Chichester, UK, 1987; Vol. 5, pp 255-276.
- [3] Curtis, C.; Kopper, R.; Decoster, E.; Guzmán-García, A.; Huggins, C.; Knauer, L.; Minner, M.; Kupsch, N.; Linares, L.M.; Rough, H.; Waite, M. Heavy-Oil Reservoirs. *Oilfield Review*, Autumn 2002, pp 30-51.
- [4] Hinkle, A.; Batzle, M.; Hill, S.; Clark, D. Heavy Oils: A Worldwide Overview. *The Leading Edge* **2006**, 25(6), pp 742-749.
- [5] Meyer, R.F.; De Witt, W., Jr. *Definition and World Resources of Natural Bitumens*, Bulletin 1944; U.S. Geological Survey, 1990; p 14. Also available at <http://infotrek.er.usgs.gov/pubs/>.
- [6] Pawlewicz, M. Heavy-Oil Resources of the United States. In *1995 National Assessment of United States Oil and Gas Resources*; Gautier, D.L., et al., Eds.; U.S. Geological Survey, 1995; p 13. Also available at <http://energy.cr.usgs.gov/1995OGData/DDS30.html>.

- [7] Dyni, J.R. Geology and Resources of Some World Oil-Shale Deposits. *Oil Shale* **2003**, 20(3), pp 193-252. Also available at http://www.kirj.ee/oilshale/vol_20_3.html.
- [8] Bates, R.L.; Jackson, J.A. *Glossary of Geology*, 3rd ed.; American Geological Institute: Alexandria, VA, 1987; p 788.
- [9] Buschkuehle, B.E.; Grobe, M. Geology of the Upper Devonian Grosmont Carbonate Bitumen Deposit, Northern Alberta, Canada. In *American Association of Petroleum Geologists Annual Meeting*, Dallas, TX, 2004; AAPG: Dallas, TX, 2004. Also available at http://www.ags.gov.ab.ca/activities/conference_presentations.html.
- [10] Advanced Resources International. *Undeveloped Domestic Oil Resources: The Foundation for Increasing Oil Production and a Viable Domestic Oil Industry*; U.S. Department of Energy, 2006. Also available at http://fossil.energy.gov/programs/oilgas/eor/Undeveloped_Domestic_Oil_Resources_Provi.html.
- [11] Bidinger, C.R.; Dillon, J.F. Milne Point Schrader Bluff: Finding the Keys to Two Billion Barrels. SPE International Heavy Oil Symposium, June 19-21, 2005, Calgary, Alberta; Society of Petroleum Engineers: Richardson, TX, 1995; SPE 30289.
- [12] National Energy Technology Laboratory. U.S. Heavy Oil Database: 2004. <http://www.nrel.doe.gov/technologies/oil-gas/Software/database.html> (accessed February 27, 2007).
- [13] Pemex. *Las Reservas de Hidrocarburos de México: Evaluación al 1 de enero de 2006*; Pemex Exploración y Producción, 2006. Also available at <http://www.pemex.com/index.cfm?action=content§ionID=2&catID=2624&subcatID=2634>.
- [14] Centre for Energy. How Are Oil Sands and Heavy Oil Used? <http://www.centreforenergy.com/generator.asp?xml=/silos/ong/oilsands/oilsandsAnd-HeavyOilOverview02XML.asp&template=1,1,1> (accessed May 1, 2007).
- [15] Harrison, R.S. The Bitumen-Bearing Paleozoic Carbonate Trend of Northern Alberta. In *Exploration for Heavy Crude Oil and Natural Bitumen*; Meyer, R.F., Ed.; Studies in Geology, Vol. 25; AAPG: Tulsa, OK, 1987; pp 319-326.
- [16] Christopher, J.E.; Knudsen, R.H. Heavy Crude Oil Potential of Saskatchewan. In *The Future of Heavy Crude Oils and Tar Sands*; Meyer, R.F., Steele, C.T., Olson, J.C., Eds.; Mining Information Services, McGraw-Hill: New York, 1981; pp 61-68.
- [17] Petersen, N.F.; Hickey, P.J. California Plio-Miocene Oils, Evidence of Early Generation. In *Exploration for Heavy Crude Oil and Natural Bitumen*; Meyer, R.F., Ed.; Studies in Geology, Vol. 25; AAPG: Tulsa, OK, 1987; pp 351-359.
- [18] Stryker, A. R.; Wadkins, R.; Olsen, D. K.; Sarkar, A. K.; Ramzel, E.B.; Johnson, W. I.; Pautz, J. *Feasibility Study of Heavy Oil Recovery in the United States*; NIPER/BDM-0225; BDM-Oklahoma, Inc.: Bartlesville, OK, March 1996.
- [19] Herron, E.H.; King, S.D. *Heavy Oil as the Key to U.S. Energy Security*; Petroleum Equities, Inc., 2004. Also available at <http://www.petroleumequities.com/cgi-bin/site.cgi?p=reportspres.html&t=5>.
- [20] Werner, M.R. Tertiary and Upper Cretaceous Heavy-Oil Sands, Kuparuk River Unit Area, Alaskan North Slope. In *Exploration for Heavy Crude Oil and Natural Bitumen*; Meyer, R.F., Ed.; Studies in Geology, Vol. 25; AAPG: Tulsa, OK, 1987; pp 537-547.
- [21] Croft, M.D.; Bidinger, C.R.; Vandergon, M.A. Unlocking the Potential of the Schrader Bluff Formation, North Slope Alaska. *Petroleum Geoscience* **1999**, 5(2), pp 127-133.
- [22] Olsen, D.K.; Taylor, E.C.; Mahmood, S.M. *Feasibility Study of Heavy Oil Recovery – Production, Marketing, Transportation, and Refining Constraints to Increasing Heavy Oil Production in Alaska*; NIPER-610; U.S. Department of Energy, 1992.
- [23] Santiago, J; Baro, A. Mexico's Giant Fields, 1978-1988 Decade. In *Giant Oil and Gas Fields of the Decade 1978-1988*; Halbouty, M.T., Ed.; Memoir, Vol. 54; AAPG: Tulsa, OK, 1992; pp 73-99.
- [24] Muir, J.M., *Geology of the Tampico Region, Mexico*; AAPG: Tulsa, OK, 1936.
- [25] Muir, J.M., Geology of the Tampico-Tuxpan Oilfield Region. In *The Science of Petroleum*; Dunstan, A.E., Nash, A.W., Brooks, B.T., Tizard, H., eds.; Vol. 1; Oxford

- University Press: London, 1938; pp 100-105.
- [26] Government of Mexico. *Mexico's Oil: A Compilation of Official Documents in the Conflict of Economic Order in the Petroleum Industry, with an Introduction Summarizing Its Causes and Sequences*; Government of Mexico: Mexico City, 1940.
- [27] Meyer, R.F.; Medaisko, G.S. *Heavy Oil and Natural Bitumen Deposits of Latin America*; OF 91-0364; U.S. Geological Survey, 1991. Also available at <http://infotrek.er.usgs.gov/pubs/>.
- [28] Rosenfeld, J.H. Economic Potential in the Yucatan Block of Mexico, Guatemala, and Belize. In *The Circum-Gulf of Mexico and the Caribbean: Hydrocarbon Habitat, Basin Formation, and Plate Tectonics*; Bartolini, C., Buffler, R.T., Blickwede, J.F., Eds.; Memoir, Vol. 79; AAPG: Tulsa, OK, 2003; pp 340-348.
- [29] Alberta Energy and Utilities Board. *Oil Reserves and Production: Alberta*; Alberta Energy and Utilities Board: Calgary, Alberta, 2006. Also available at http://www.energy.gov.ab.ca/docs/oilsands/pdfs/PUB_osgenbrf2004.pdf.
- [30] Heidrick, T; Godin, M. *Oil Sands Research and Development*; Alberta Department of Energy and Alberta Energy Research Institute: Edmonton, Alberta, Canada, 2006. Also available at http://www.aeri.ab.ca/sec/new_res/docs/OilSands_Private_Final_27Apr07.pdf.
- [31] Woyntonowicz, D.; Severson-Baker, C.; Raynolds, M. *Oil Sands Fever: The Environmental Implications of Canada's Oil Sands Rush*; The Pembina Institute: Drayton Valley, Alberta, 2005. Also available at <http://www.pembina.org>.
- [32] Hubbard, S.M.; Pemberton, S.G.; Howard, E.A. Regional Geology and Sedimentology of the Basal Cretaceous Peace River Oil Sands Deposit, North-Central Alberta. *Bulletin of Canadian Petroleum Geology* **1999**, *47*(3), pp 270-297.
- [33] Creaney, S.; Allan, J. Hydrocarbon Generation and Migration in the Western Canada Sedimentary Basin. In *Classic Petroleum Provinces*; Brooks, J. Ed.; Special Publications, Vol. 50; Geological Society: London, 1990; pp 189-202.
- [34] Reid, T.B.; Mikels, R. *U.S. Tar Sands Deposits*; Department of Energy, Office of Fossil Energy, 1993. Also available at <http://www.oildrop.org/lib.html>.
- [35] Oblad, A.G.; Bunger, J.W.; Hanson, F.V.; Miller, J.D.; Ritzma, H.R.; Seader, J.D. Tar Sand Research and Development at the University of Utah. *Annual Review of Energy* **1987**, *12*, pp 283-356.
- [36] Ritzma, H.R. *Oil-impregnated Rock Deposits of Utah*; Map 47; Utah Geological and Mineralogical Survey, 1979. Also available at <http://geology.utah.gov/online/m/m-47.pdf>.
- [37] Campbell, J.A.; Ritzma, H.R. Geology and Petroleum Resources of the Major Oil-Impregnated Sandstone Deposits of Utah. In *The Future of Heavy Crude Oils and Tar Sands*; Meyer, R.F., Steele, C.T., Olson, J.C., Eds.; Mining Information Services, McGraw-Hill: New York, 1981; pp 237-253.
- [38] Bureau of Land Management. *Final Mineral Report: Mineral Potential Report For The Vernal Planning Area*; U.S. Department of the Interior, 2005. Also available at <http://www.blm.gov/rmp/ut/vernal/documents.htm>.
- [39] Kuuskraa, V.A.; Hammershaimb, E.C.; Pague, M. Major Tar Sand and Heavy Oil Deposits of the United States. In *Exploration for Heavy Crude Oil and Natural Bitumen*; Meyer, R.F., Ed.; Studies in Geology, Vol. 25; AAPG: Tulsa, OK, 1987; pp 123-135.
- [40] Connan, J; Coustau, H. Influence of the Geological and Geochemical Characteristics of Heavy Oils on Their Recovery. In *Exploration for Heavy Crude Oil and Natural Bitumen*; Meyer, R.F., Ed.; Studies in Geology, Vol. 25; AAPG: Tulsa, OK, 1987; pp 261-279.
- [41] Macauley, G. *Geology of the Oil Shale Deposits of Canada*; Open-File Report 754; Geological Survey of Canada, 1981. Also available at http://ess.nrcan.gc.ca/esic/index_e.php.

- [42] Moore, S.W.; Solomon, B.J. Preliminary Results of Core Drilling and Other Geologic Studies of Paleogene Oil Shale-Bearing Deposits Near Elko, Nevada. In *Proceedings of the 15th Annual Oil Shale Symposium Proceedings*, Golden, CO, April 27-30, 1982; Gary, J.H., Ed.; pp 69-78.
- [43] Wikipedia. Sequence stratigraphy. http://en.wikipedia.org/wiki/Sequence_stratigraphy (accessed February 27, 2007).
- [44] Schlumberger Limited. Acquisition. <http://www.glossary.oilfield.slb.com/Display.cfm?Term=acquisition> (accessed February 27, 2007).

4

**Production/Processing Technologies
for Unconventional Oil Resources**

4 Production/Processing Technologies for Unconventional Oil Resources

Unconventional oil, defined in Section 3, can be produced from three distinct resources. First are the heavy oil/extra heavy oil reservoirs like the Kern River Field in California and the large fields on the North Slope of Alaska. Most of the heavy oil being produced from these reservoirs has an API gravity between 10°–20°. Second are the oil sand reservoirs like the Athabasca region in Alberta, Canada and the Uinta and Paradox Basins in Utah. The bitumen associated with oil sands typically has API gravities of 10° or lower. Third are the oil shale deposits, which are located predominantly in the western United States. The kerogen impregnated in the shale has an API gravity of less than 10°. However, since thermal technologies are employed for “releasing” oil from kerogen, the resulting shale oil may have an API gravity of 20°–40°.

Apart from high densities, oils associated with these resources have very high viscosities. In fact, the United States Geological Survey (USGS) definition of oil sands (tar sands) is a material with gas-free viscosity of greater than 10,000 cP. In most situations, there is not sufficient reservoir energy for primary production. As oil viscosity is an exponential function of temperature, the best option for producing oil from these sources is to increase the temperature to reduce viscosity.

The production processes for oils/bitumen from these three resources can be broadly classified according to whether the oil is produced “in-place” (in situ) or the oil-bearing material is processed on the surface (ex situ). In situ processes are employed for deep deposits while ex situ processes are amenable to shallow deposits with little overburden.

In situ production methods for heavy oil/extra heavy oil are adaptations of technologies used in producing conventional (light to medium) oil. The additional step of viscosity reduction is required before the heavy oil can be pumped from the ground using equipment intended for light to medium oils. The two options for reduction of viscosity in situ are: (1) steam injection or (2) in situ combustion. Although both of these methods have been used in California heavy oil production, steam injection is most commonly employed due to the difficulty in controlling in situ combustion.

In situ technologies for production of bitumen from oil sands are modifications of steam injection technologies for heavy oil reservoirs. The best known technology is steam-assisted gravity drainage (SAGD). In situ production methods account for approximately 40% of the 1.2 million BOPD of Canadian bitumen production [1]. The contribution to Canadian oil production from in situ production is expected to grow and dominate the targeted 3 million BOPD of production in the next ten to fifteen years [2]. Other in situ technologies such as solvent extraction and in situ combustion have not reached the commercialization stage.

In situ technologies for the production of oil from oil shale were the focus of intensive research efforts during the 1970s and 1980s. At that time, the preferred method was to rubbalize the shale using explosives and then to operate a downhole retort [3]. Research results on direct heating were also reported but did not receive much attention [4]. Announcement of the Shell In situ Conversion Process (ICP) has brought the direct heating process to the forefront [5,6].

Centipoise (cP) is one hundredth of a poise, a unit of viscosity in the centimeter-gram-second unit system.

Oil in most oil reservoirs has some dissolved gas which lowers oil viscosity. The USGS definition of oil sands applies to gas-free oil derived from oil sands.

Oil is produced from conventional oil reservoirs by primary production. In this process, as pressure decreases, dissolved gas comes out of solution and provides the reservoir energy for the oil to be produced. This energy does not exist in most oil sand reservoirs due to little or no dissolved gas content.

With in situ combustion, air injection is followed by the propagation of a fire front through the reservoir.

BOPD refers to barrels of oil per day.

In downhole retorting, material is not transported to the surface but is thermally processed “in-place” to produce oil and gas.

Surface extraction and processing techniques have not been used in U.S. heavy oil production due to the depth of most of the deposits. However, in the Athabasca region of Canada, mining has provided access to vast quantities of oil sands deposits with little or no overburden. The uniform richness of the Canadian deposits coupled with the unconsolidated nature of the sands have made commercial development of mining and extraction processes possible. Through extensive research over 30 years, two Canadian companies, Syncrude and Suncor, have optimized the process for the separation of bitumen from sand [7]. Efficiencies of scale are realized by conducting very large mining and processing operations. Surface extraction processes are solvent-based, with water being the most common solvent; other (mainly hydrocarbon) solvents have been reported, but are not yet commercial [8].

The soil/rock material that covers the deposit at the surface is called the overburden.

Oil shale research also focused on surface processing in the 1970s and 1980s. Results indicated that solvent extraction methods were not suitable for oil shale because of the chemical characteristics of the kerogen and the complete association of organic and inorganic matter in shale. Instead, thermal processing via pyrolysis or combustion is necessary to obtain oil from shale [9].

4.1 Production Processes for Heavy Oil

Heavy oil has been produced in the United States for over 80 years. A comprehensive technology review was undertaken by Dowd et al. in 1988 [10]. An update report published in 1996 [11] provided a detailed account of the heavy oil reservoirs in the United States. It concluded that about 90% of the estimated 68 billion barrels of heavy oil resource in the lower 48 states was in the state of California. Consequently, most of the current heavy oil production is in California; in 2005 California heavy oil production was approximately 450,000 BOPD [12,13]. There are also large heavy oil resources in Alaska, but Alaskan heavy oil production is still low relative to light oil production and to total heavy oil production in the United States. In 2003, combined Alaskan heavy oil production from the Schrader Bluff Formation in the Milne Point Unit and the West Sak Formation in the Kuparuk River Unit was 26,800 BOPD. In that same year, total Alaskan oil production was 1.02 million BOPD [14].

Both Canada and Mexico also report significant but declining production of heavy oil, but both countries use definitions of heavy oil that vary from that used in this report (see Section 3). Pemex, the Mexican state oil company, reported production of 2.4 million BOPD of heavy crude during 2005. In 2006, reported production was down 6% from 2005 [15]. Pemex defines heavy oil as that with an API gravity of less than 27°. Most of the heavy oil produced in Mexico is Maya crude with an API gravity of 22° [16]. Similarly, the Canadian Association of Petroleum Producers (CAPP) reported that Canada produced 476,000 BOPD of heavy oil in 2005, down from 497,000 BOPD of heavy oil produced in 2004 [17]. CAPP defines heavy oil as that with an API gravity of less than 28° [17].

An update on total production from California heavy oil reservoirs (10°-20° API) is provided in Figure 4-1 for the years from 1991-2005 [14]. This total includes primary production as well as steamflood and cyclic steam production. As seen in the figure, heavy oil production is declining. Continued high oil prices have spurred additional investment and drilling in California, the effect of which might be a slower decline in production in 2006-2007. However, unless other large fields come on line as will be discussed later, it is unlikely that the observed decline will be arrested.

Figure 4-1. California heavy oil production and steam injection to produce the heavy oil during the period 1991-2005.

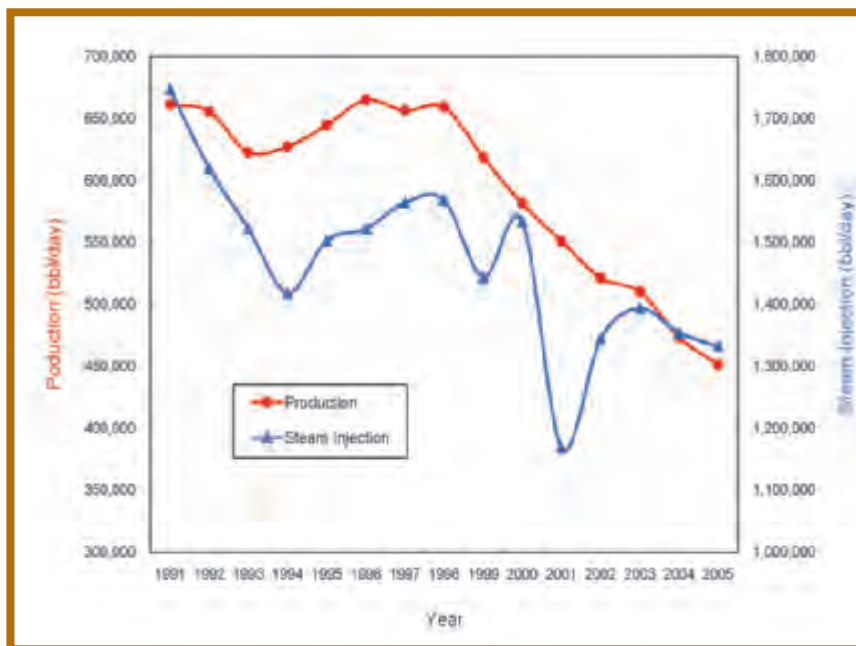

Source: California Division of Oil, Gas, and Geothermal Resources, California Department of Conservation, 1991-2005

Since heavy oil is primarily produced using steam injection technologies, e.g. steamflood/steamdrive processes, total steam injection in California during the period from 1991-2005 is also shown in Figure 4-1. The NIPER/BDM report estimated that about 8 billion of the 68 billion barrels of heavy oil in the lower 48 states could be recovered using steam injection technologies [7]. Profitability of the steamflooding operation depends on the energy source used to generate the steam and the cost of that source. Natural gas is the predominant energy source in California steamfloods. A steam to oil ratio (SOR) of 3 is profitable when oil prices are in the \$30-\$35 range, even if natural gas in the price range of \$8-\$10/ MMBTU (2007 pricing) is used as the energy source. However, since oil extraction is a capital-intensive industry with significant depreciation expenses, steamflood operations can remain cashflow positive at oil prices in the low \$20 range; see Section 6.1.1 for additional economic analysis of steamfloods.

The sizeable dip in steam injection in 2001 is the result of a large spike in natural gas prices in California. Oil production levels were not significantly affected during the time of steam injection reduction, possibly because steamfloods in California are mature and average reservoir temperatures are high. It takes time for the reservoir to cool and the effect of heat input reduction to be felt. Oil production was also maintained by efficient heat management practices (discussed below). Current high natural gas prices may be influencing the heavy oil production decline in California.

4.1.1 Evolution of Steam Injection Technologies

Steamflood/steamdrive processes are well established Enhanced Oil Recovery (EOR) methods and are most commonly applied to heavy oil reservoirs. Following steam injection, the primary heavy oil recovery mechanisms are reduction in crude oil viscosity, gravity drainage of oil as the steam overrides, and steam distillation of oil.

In a steamflood/steamdrive process, steam is injected into the heavy oil reservoir through injection wells and oil, steam, gases and water are produced from a second set of wells, the production wells.

SOR is the amount of water equivalent barrels injected per barrel of oil produced.

Approximately 1 cubic foot of natural gas produces 1,000 BTU of energy. MMBTU stands for 1,000,000 BTU.

Depreciation expenses are accounting expenses that do not have a corresponding cash outlay.

EOR methods include any of several techniques that result in increased production of oil from a subsurface reservoir.

The density of steam is much lower than the density of oil and as a result it rises and expands to form a steam chamber, contacting oil at the top of the formation. This phenomenon is called steam override.

Modern commercial steamfloods began in 1952 in California's Yorba Linda Field. Throughout the 1950s and 1960s, steam injection was applied to reduce oil viscosity with little consideration for the oil recovery processes involved. As oil prices rose to high levels in the 1970s, steamflooding became the predominant heavy oil recovery method. Natural gas was the fuel of choice for steam generation; low natural gas prices during this period helped enhance the use of thermal methods for oil recovery [18]. With the recognition that steam override and subsequent gravity drainage of the oil together with reservoir characteristics determine the process effectiveness, heat management methods were instituted to reduce the amount of steam injected over the life of the flood. Sophisticated reservoir simulation studies have shown that it is essential to capture geologic heterogeneities and to account for the effects of discontinuous source rock in order to match production and temperature data for the purpose of determining further field development strategies.

The evolution of heavy oil processing in California over the last 40 years is summarized in Figure 4-2 [18]. Cyclic processes outnumbered the steamflood/steamdrive processes in the early development of the heavy oil resource. As experience and knowledge grew regarding the steamflood/steamdrive processes, their numbers increased relative to the cyclic processes, despite being more capital intensive and, in general, requiring more reservoir characterization and planning. Cyclic processes still play a significant role; the continuous injection of steam in steamflood/steamdrive processes is usually preceded by cyclic steam stimulation treatments. Additional information about steamflooding can be found in the monograph of Sarathi and Olsen [19].

In a cyclic process, a single well is used for injection and production, i.e. steam is injected into a well and oil is produced from the same well. In most practical applications, a steamflood/steamdrive starts as cyclic process to "loosen-up" the oil and then proceeds to a flood.

A steam of 70% quality is typically injected, although this varies from project to project.

Figure 4-2. Breakdown of steamflood/steamdrive processes in California over a 40-year period.

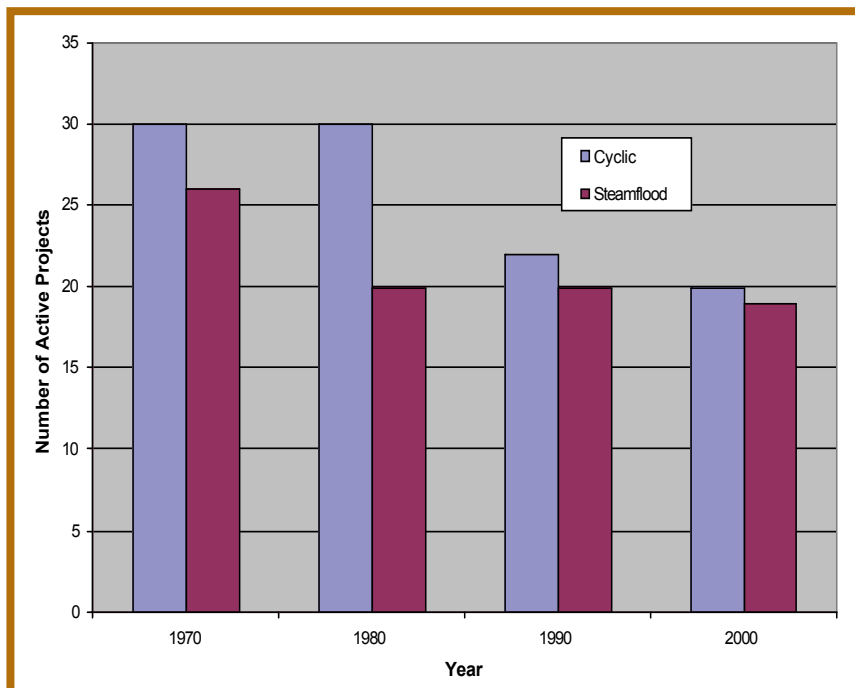

Source: E.J. Hanzlik and D.S. Mims, *Forty Years of Steam Injection in California – The Evolution of Heat Management*, 2003

4.1.2 Reservoir and Performance Monitoring

In contrast to the early days of the technology when steam injection was maximized, complex reservoir data analyses and process monitoring methods are now being used to manage steamfloods and to reduce the amount of steam used. The most effective optimization strategy involves three stages of heat management [20]. In the monitoring stage, parameters to be measured are identified and data is collected. In the analysis stage, reservoir data is compared to analytical or simulation models. In the process modification state, operational parameters are changed based on process understanding.

The chain of events in this work flow, shown in Figure 4-3 [20], illustrates that reservoir monitoring is the centerpiece of any steamflood management strategy. The most common measurements are (1) temperatures and pressures in injection, production and observation wells, (2) pulsed neutron capture (PNC) logs in the injection and production wells to assess fluid flow paths, (3) spinner surveys and (4) fluid flow rates of steam, oil and gases. Additionally, seismic tests are performed to monitor the progress of the steam front and the extent of the steam chamber. Occasionally, tracer tests are performed to determine flow paths within the reservoir. Once measurements are made, process performance can be assessed by comparison with existing models or by using reservoir simulations. At this stage, it is possible to evaluate if the heat being injected into the reservoir is effective or not. If effective, a judgment is made regarding the primary mechanism in play. The rate of injection (which determines process economics) can then be adjusted and the monitoring cycle begins again.

Pulsed neutron capture involves the bombardment of a formation with high-energy neutrons. The neutrons interact with different nuclei, producing characteristic gamma ray emissions that are used to measure fluid saturations in the reservoir.

Spinner surveys are production logging tools used to determine how much of each fluid is coming from different vertical portions of the well.

Figure 4-3. Heat management in a steamflood process.

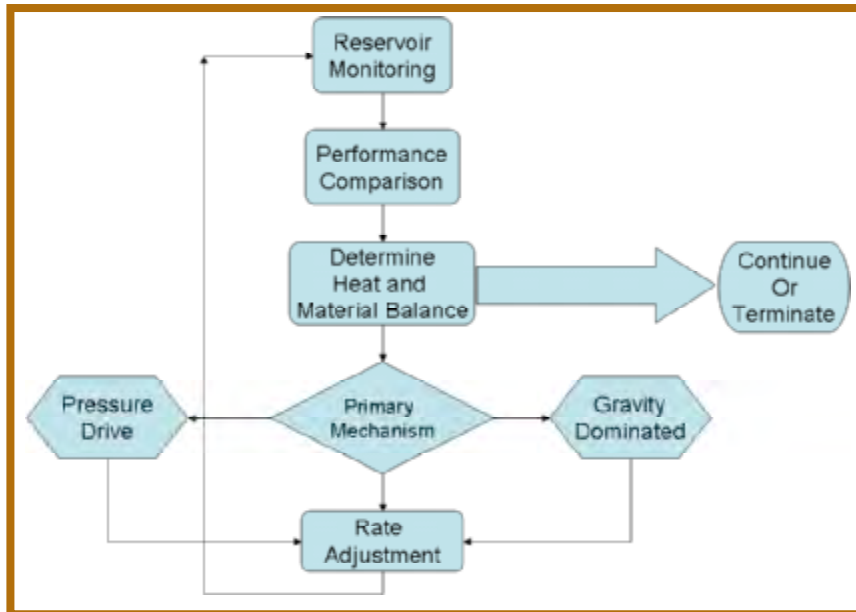

Source: V.M. Ziegler et al., *Recommended Practices for Heat Management of Steamflood Projects*, 1993

4.1.3 Screening Criteria for Steamflood Technologies

In evaluating heavy oil resources, the NIPER/BDM report [11] made use of empirical correlations that predict success or failure of the flood based on some reservoir parameters [21]. New screening criteria for steamflood technologies are based on updated

production data from a number of heavy oil reservoirs [22,23]. The process is applied to oils of low gravity (10°-20° API) and in oil reservoirs with viscosities in the range of 100-5000 cP. The screening process is generally applied to relatively shallow reservoirs (<4920 feet/1500 meters) with thick sands (net thickness ≥ 33 feet/10 meters). Porosities over 20% and permeabilities over 200 mD are desired. The presence of a gas cap or of faults and fractures in the reservoir may impact the process adversely. Similarly, steamflooding is not recommended for highly heterogeneous formations, where the progress and growth of the steam front is negatively impacted.

Permeability, which is a measurement of a rock's ability to transmit fluids, is typically measured in darcies (D) or millidarcies (mD). It is not an SI unit but is widely used in petroleum engineering and geology.

4.1.4 Models for Steamflood Performance

The analytical models for the calculation of steamflood performance are well developed. In these models, the initial emphasis was on the calculation of the size of the steam zone by performing heat loss, heat transfer and material balance calculations. These models were based on frontal advance as shown in the top panel of Figure 4-4. In the mid 1980's, it was recognized that due to gravitational force, steam overrides and oil is produced by gravity drainage as shown in the bottom panel in Figure 4-4. As a result, models were developed to better account for the vertical expansion of the steam chamber [24,25]. These analytical models provide the area covered by steam, the volume of oil produced, and first-order estimates of oil production rates given oil properties and steamflood conditions.

Figure 4-4. Evolution of steamflood theory from a pressure displacement process to a gravity drainage process.

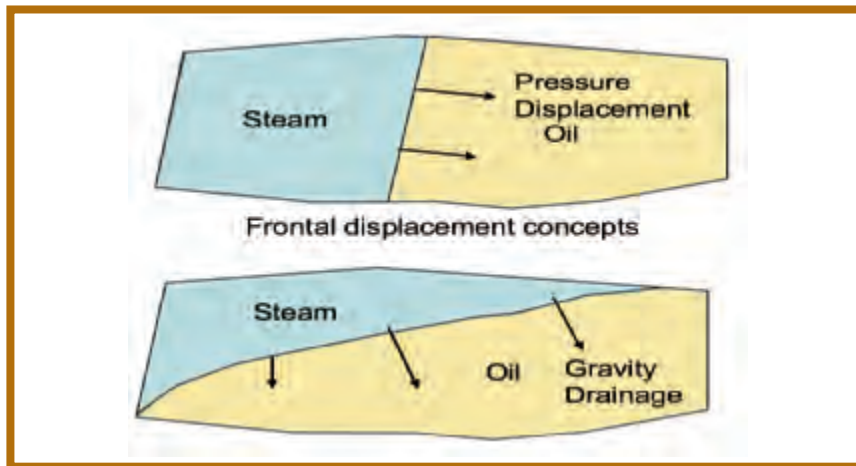

Source: Utah Heavy Oil Program

For more accurate predictions of reservoir conditions, reservoir simulations must be used. However, such simulations require detailed information about the reservoir and significant computational time. Reservoir characterization needed for simulations is obtained using a variety of tools such as seismic surveys, logs, outcrop analyses, etc.

4.1.5 New Technology Impacts and Future Research

As steamflooding is a mature technology, research and development in steamfloods is centered around managing the floods more efficiently. Studies have shown that the heat balance for mature projects needs to be computed correctly, accounting for the specific reservoir geometries [26]. With an accurate heat loss description, it is possible to reduce heating requirements up to 30%. This section briefly describes recent devel-

opments and future work in simulation and process monitoring techniques to achieve more accurate heat balance calculations.

First, significant advances have been made in the application of reservoir simulators for managing steamfloods. It is important to represent the geologic complexity of the reservoir to the fullest extent possible to match observed performance and to predict future trends and infill drilling potential. It is also important to recognize the continuous nature of the reservoirs in a number of locations so that the boundary conditions are correctly assigned [27]. New models have attempted to understand the lateral contiguity of shale (source rock) layers; holes in these layers act as chimneys, allowing steam to escape and oil to drain to lower sands [28]. A number of studies have shown the viability of using strategically placed horizontal wells to capture oil [29-32]. The necessity of tight integration between geological characterization, geophysical analyses, geostatistics, reservoir simulation and process monitoring for better reservoir management has also been highlighted in a few papers [29,31-32].

Additional work is needed to understand the fundamental processes being simulated. In most instances, the three phases in steamflood models are the oil, the water and the steam. The viscosity reduction of oil is accounted for accurately in most models. However, steam distillation and compositional variation in oil are usually not considered. The formation of emulsions and emulsion properties are generally not modeled accurately.

Second, since the quality and quantity of steam is of paramount importance in process effectiveness, it is critical to monitor this aspect of the flood. Tools and devices available to accomplish this task include the use of impacting tees to maintain uniform steam quality, the control of steam rates at each wellhead using a “flow-choke”, the use of a two-phase separator to check steam rate and quality periodically, and the measurement of upstream and downstream temperatures to monitor wellhead rates [33].

Third, reservoir sensing and monitoring techniques have significantly improved. One important technological advance is the identification of steam breakthrough intervals through distributed temperature sensing (DTS) [34]. Cost-effective, fiber-optic DTS technology operates continuously at high temperatures and is very effective in obtaining wellbore temperature profiles at multiple points for process and system diagnosis. Coupled with accurate reservoir simulation, it has the potential to be an effective reservoir management tool [35].

Fourth, steam distribution systems have advanced in recent years. Slimhole steam injector technology uses thin injectors to deliver steam to the reservoir, a low-cost and effective means of distributing steam evenly over the entire reservoir volume [36]. However, subsequent costs associated with leaks, tubing deformation, and steam migration may negate the initial advantages. A variation on slimhole technology, a water alternating steam process, has been shown to be viable but has not been widely used [37]. Further research is required before this technology is applied on a large scale.

Fifth, potential means of lowering steamflood costs have been proposed. Nuclear Magnetic Resonance (NMR) imaging of the formation coupled with conventional well logging has been used to obtain more accurate oil volumes [38]. Multiphase wells

A sophisticated network of pipes and tubes can improve steam distribution and maintain steam quality. An impacting tee is one such device.

Breakthrough is the term used for rapid increases in steam content at the production well. Due to reservoir heterogeneities and flood mechanics, steam may breakthrough in definite well intervals. Identification of these intervals is important to better manage the floods.

Water is injected alternately with steam to maintain a better profile and to scavenge heat from the formation.

with downhole separation technology have also been proposed for lowering steam-flood costs [39], but test results have not been consistent. The use of a multiphase metering system, where the flow of oil, steam and water are measured prior to separation, has been demonstrated for a light oil steamflood in Indonesia and in some California heavy oil fields [40]. For extremely shallow fields (<98 feet/30 meters deep), blanket heating using steam-circulating pipes has been proposed [41], but there are no commercial applications of the technology thus far. A semi-automated approach using a set of devices and methods to optimize steamfloods, collectively titled Production Enhancement Tools (PET), has been suggested [42]. The PET methodology includes the identification of wells to be shut and wells needing treatment, the determination of infill locations, and the adjustment of injection and production parameters. The use of Electrical Downhole Steam Generation (EDSG) has also been reported [43]. The concept is to use advanced electric heaters to generate steam downhole to overcome “local” air pollution issues when steam is generated using inefficient boilers at the surface. However, this technology has yet to see widespread use.

In downhole separation, steam, water and oil are separated by gravity at the point of production (“downhole”) and transported by separate pumps to the surface.

PET include diagnostic tools, heterogeneity index, Voronoi gridding, bubble maps and pattern analysis.

4.1.6 Selected Field Surveys

The NIPER/BDM report [11] shows that, excluding Alaska, more than 90% of the heavy oil reserves in the United States are in California. In this section, information about three of the largest California fields is summarized. The PRU-Fee study has been included to show that, even in mature technologies, interdisciplinary scientific efforts can produce significant improvements. The Kern River and Coalinga studies have been included because there is information on the progress of these steamfloods extending over the past four decades. General background information, production methods and improvements used, and some production statistics are provided in each case.

4.1.6.1 PRU Fee in the Midway-Sunset Field

The Midway-Sunset field was discovered in 1894, but it took nearly a decade for commercial production to begin. The original 13 wells drilled on the Pru Fee property in the early 1900s were operated in primary production mode until 1969, when infill drilling and cyclic steaming were initiated. During the half century of primary production, nearly 1.8 MMBO were produced from the Pru Fee property, but production declined steadily and reached insignificant quantities by the late 1960s. Cyclic steaming was successful in extracting more of the remaining viscous 13° API oil until the Pru Fee property was shut down in 1986 as not economically viable [29].

MMBO is million barrels of oil.

In 1995, the shut-in Pru Fee property was selected for a DOE Class 3 oil technology demonstration and was brought back into commercial production through tight integration of geologic characterization, geostatistical modeling, reservoir simulation, and petroleum engineering. This property has a 230-328 foot (70-100 meter) thick oil column in the Monarch Sand, part of the upper Miocene Beldridge Diatomite Member of the Monterey Formation. However, the sand has a shallow dip (about 10°) that inhibits gravity drainage, lacks effective steam barriers within the pay interval, and has a thick, water-saturated transition zone above the oil-water contact. These factors required an innovative approach to steamflood production design that balanced optimal total oil production against economically viable production rates and performance factors such as SOR and Water Oil Ratio (WOR) [31].

Since steam generation is the most significant cost component of a steam injection process, SOR is the primary technical index that determines the economic effectiveness of the flood.

Several old wells in the center of the property were recompleted and put into cyclic

Water Oil Ratio (WOR) is the ratio of the volume of water produced to the volume of oil produced.

production to evaluate the feasibility of thermal recovery at this marginal site. In January 1997, the project entered its second and principal phase with the purpose of demonstrating whether or not steam was an effective mode of production in an 8 acre (0.03 square kilometer), four-pattern pilot. The early production success of the pilot and the discovery of significant quantities of oil in the overlying Pleistocene Tulare Formation during the preparation of the steamflood pilot led the company involved to expand operations elsewhere in the Pru Fee property in early 1998. After 49 months of steam flood production of the four-pattern pilot, 562,366 barrels of oil were produced and production continues today with about 60 producers and 20 injectors in a 40 acre (0.16 square kilometer) area [31].

Reservoir simulations with geostatistically generated data sets revealed that the initial fluid distribution in the reservoir had the most significant impact on the economics of the steamflood process. The production strategy adopted in the steamflood pilot involved steam injection within the upper third of the oil column where the oil saturation is greater than 50%, thus avoiding undue loss of heat to water [44].

4.1.6.2 Kern River Field

The Kern River Field, comprised of the Kern River Series sands, is a large, shallow heavy oil reservoir located five miles (8 kilometers) northeast of Bakersfield, California. The Kern River Field reservoir consists of an alternating sequence of unconsolidated sands with considerable interbedded silts and clays. Reservoir depths are between 400-1400 feet (120-420 meters), and the thickness of the sands varies between 25-125 feet (7-40 meters). Typical porosities are 30% and permeabilities are 1-5 D. The produced oil varies in density from 9°-16° API [45].

Kern River Field, which is comprised of hundreds of patterns over several major leases, is one of the biggest success stories in the steamflooding process. The steamflood effort began in the mid to late 1960s. During 1970 and 1971, 514 inverted 5-spot steamflood patterns were installed. The 80-pattern (210 acre/0.85 square kilometer) Canfield Expansion Project targeted about 20 million barrels OOIP and resulted in recoveries of over 70% OOIP. The injection rate of steam during the production period was about 400 barrels per pattern for an average SOR of 8. The oil recovery averaged 0.5 barrels of oil/MMBTU of steam injected. The Canfield lease averaged 155,000 barrels of oil per 2.6-acre (0.01 square kilometer) pattern. The large Green and Whittier lease, which comprised 114 patterns over 300 acres (1.2 square kilometers), averaged 110,000 barrels per pattern. The 70-pattern San Joaquin expansion averaged 131,000 barrels of oil per pattern [45].

Improved recovery from this mature steamflood has been a research topic for many years. A 1980 analysis of the post-flood cores suggested that recovery could be improved by restricting production intervals and by using foam diverters [45]. In 2001, Williams et al. [28] reported on the effect of discontinuous shales on multizone steamflood performance in the Kern River Field. In this study, the performance of the Kern River Monte Cristo I reservoir was compared to a new reservoir simulation model that represented the heterogeneities of all the reservoir zones. An 18-pattern area comprised of 2.6-acre (0.01 square kilometer) inverted five spots was considered and the results showed that different portions of the reservoir may yield different recoveries. Actual cumulative oil recovery from this pattern over 20 years was about 5 million barrels of oil. This amounted to a recovery of about 60% OOIP for all the zones together,

Post-flood cores are removed from the reservoir after the passage of the steam front to observe how the flood performed.

Discontinuous shales allow significant oil drainage from upper to lower sands as well as fluid migration across zones. This phenomenon results in lower oil yields from unsteamed upper zones.

even though the recovery varied significantly across various zones. Recent studies have shown that recoveries can be improved by understanding the reservoir geology in detail and by using advanced monitoring and well completion technologies [29].

4.1.6.3 Coalinga Field

The Coalinga field, located on the west side of the San Joaquin Valley approximately 100 miles (161 kilometers) northwest of Bakersfield, is one of the oldest oil fields in California. The field was discovered in 1887 and is approximately 5 miles (8 kilometers) wide and more than 13 miles (21 kilometers) long. Steamflood operations began in 1964. Production in the field is primarily heavy crude from the Middle Miocene Temblor formation. In the Coalinga area, the Temblor deposition is a marginal marine environment characterized by channelized sands and numerous flooding cycles that created a sequence of sands 10-35 feet (3-10 meters) thick, separated by shale and mudstone units of similar thickness. Low-porosity zones composed of calcite-cemented fossil shell detritus further compartmentalize the reservoir sands [46].

The Temblor sands comprise the major reservoir at 500-2,000 feet (166-666 meters) with 33% porosity and 12°-14° API oil. Each Temblor sand is at a different stage of drainage and thermal maturity. The thin sands and the 0.5 to 0.7 net-to-gross ratio contribute to high heat losses during steamflooding. Permeability is low in some areas of the field, creating injectivity problems. In other areas, there are regions of high permeability that contribute to premature steam breakthrough [46].

Approximately 4,500 wells have been drilled since 1887, and the last major steamflood expansion was implemented in 1998. Currently, there are 696 active producers and 139 active injectors in West Coalinga. Development work is focused on expansion projects adjacent to existing operations. For the entire Coalinga Field, production was about 6.4 million barrels of oil in 2005 [46].

Steam production represents the single largest operating expenditure, and managing this expense is critical to Coalinga's success. Starting in 2002, ChevronTexaco has followed an aggressive plan in Coalinga to manage and optimize steam injection by use of monitoring tools and of maintenance and growth heat-calculation tools.

4.1.7 In Situ Combustion

In situ combustion is attractive because some of the heaviest fractions of the oil are used to sustain the fire front with substantial savings in the energy requirements of the process. In practice, however, in situ combustion has been a very difficult process to control. A review of 12 in situ combustion projects is found in [10].

The most successful in situ projects in California include the South Belridge, MOCO T in Midway-Sunset and Santa Fe's Midway-Sunset Project [47]. Despite being technically successful, some of the projects have been significantly downsized while others have been abandoned or converted to steam injection. No new large projects have been initiated due to the operational difficulties of in situ combustion. These technologies may be more applicable to heavier oils as discussed in emerging technologies for oil sands in Section 4.2.3 of this report.

One measure of heterogeneity in oil reservoirs is the net-to-gross ratio. This is a ratio of the volume of oil-containing rocks to the total volume of all the rocks.

A producer is a producing well and an injector is a well where steam injection takes place.

4.2 Production Processes for Oil Sands

Oil sand is defined as any consolidated or unconsolidated rock, exclusive of coal or oil shale, that contains a hydrocarbon material known as bitumen with a viscosity greater than 10,000 cP at reservoir temperatures (see Section 3). Oil sands are generally comprised of crude bitumen, sand, water, and clay. In practice, the bitumen does not flow and cannot be pumped without being heated, diluted, or upgraded. Bitumen must also be upgraded to reduce sulfur, nitrogen and other heteroatoms (including metals) prior to refining. Production processes for oil from oil sand deposits fall into two distinct categories: (1) surface mining and processing and (2) in situ production methods. Surface mining and processing technologies are used when the deposits are shallow and the overburden is not extensive (<100 feet/30 meters). In situ processes are employed for deposits deeper than about 1000 feet (300 meters). If a deposit has significant overburden but is not deep enough for in situ processing, or if the formation does not have good cap-rock to contain injected steam, neither of the options can be used. These technologies are discussed in more detail in the following sections.

A heteroatom is any atom in the bitumen-derived fuel that is not carbon or hydrogen. Typical nonmetal heteroatoms include nitrogen, oxygen, and sulfur. Metal heteroatoms include vanadium and nickel.

4.2.1 Oil Characteristics

The major deposits of oil sands in the United States are in eastern Utah, while North American oil sands production experience is concentrated in Alberta, Canada. Table 4-1 shows physical properties and chemical compositions of four different bitumens obtained from oil sand deposits in the Uinta Basin of Utah [48,49]. Similar properties for two Canadian bitumens are listed in Table 4-2 [50]. For both Utah and Canadian bitumens, the API gravities vary with their origin. Utah and Canadian oil sands differ in terms of (1) saturates, aromatics, resins and asphaltenes (SARA) and (2) heteroatom concentrations (sulfur, nitrogen and metals). With the exception of bitumen from Tar Sand Triangle (not shown in Table 4-2), the Utah bitumens contain significantly lower sulfur than the Canadian bitumens, a major advantage in subsequent upgrading applications. Moreover, bitumen from Utah oil sands is at least an order of magnitude more viscous than the Canadian bitumen at reservoir conditions as noted in Table 4-3 [51].

Utah oil sands are geologically condensed, relatively shallow, oil-impregnated sandstone deposits. Of the well-known, mapped deposits, the total resources are estimated to be in the range of 19-24 billion barrels with proven reserves of 8-12 billion barrels of 8°-14° API oil in the form of bitumen (see Section 3.2.2). Although a number of attempts have been made to exploit these deposits, low oil prices coupled with social and environmental barriers led to the termination of most projects between 1980 and 2000. Nevertheless, technology continues to be developed, and the environmental concerns are being addressed and overcome [52-54].

Table 4-1. Typical physical and chemical properties of Utah oil sands bitumen.

Properties	Whiterocks	Asphalt Ridge	PR Spring	Sunnyside
S.G. (15/15°C)	0.98	0.985	1.005	1.015
API gravity	12.9	12.1	9.3	7.9
CCR, wt%	9.5	13.9	14.17	15.0
Pour point, °C	54	47	46	75
Ash, wt%	0.8	0.04	3.3	2.4
Viscosity, @70°C (Pa·s)	4,825	5,050	47,000	173,000
Molecular weight	635	426	670	593
SARA, wt%				
Saturates	35.7	39.2	33.4	20.0
Aromatics	7.0	9.0	3.6	15.1
Resins	54.5	44.1	43.8	36.8
Asphaltenes ^{a)}	2.9	6.8	19.3	23.6
Elemental analysis, wt% (Dry, ash-free basis; oxygen calculated by difference)				
C	85.0	85.2	84.7	83.3
H	11.4	11.7	11.2	10.8
N	1.3	1.0	1.3	0.7
S	0.4	0.6	0.5	0.6
O	1.6	1.1	1.8	4.4
H/C	1.56	1.65	1.60	1.56
Distillation cuts, wt%				
Volatilities (< 538°C)	46.6	53.5	45.4	40.9
< 204°C	0.5	1.3	0.4	0.6
204 - 344°C	7.4	11.8	8.2	7.8
344 - 538°C	38.7	40.4	36.8	32.5
> 538°C	53.4	46.5	54.6	59.1

a) Pentane insolubles

Source: A.G. Oblad et al., *The Extraction of Bitumen From Western Oil Sands*, 1997; A.G. Oblad et al., *Tar Sand Research and Development at the University of Utah*, 1987

S.G. or specific gravity is the density of a substance divided by the density of water.

Conradson Carbon Residue (CCR) provides an index on how well the oil can be refined.

Pour point is the temperature at which a material begins to flow.

Viscosity is a substance's internal resistance to flow.

The percent by weight of a component in a mixture is weight percent (wt%).

Oils are made of thousands of components of varying molecular weights. Molecular weight of the bulk crude oil is reported here.

Oil can be separated based on the polarity of its constituents. SARA is a polarity-based separation. Saturates, which are least polar, are eluted first, followed by aromatics, and then resins.

Asphaltenes are a specific compound class in crude oils. When normal pentane is added to the oil in a definite proportion, solids come out of the oil. These solids are called asphaltenes.

In distillation, crude oil is separated according to the boiling points of the various constituents in the oil with lighter constituents (gasoline) being separated first, followed by slightly heavier components, etc. These boiling fractions are called distillation cuts.

Table 4-2. Typical physical and chemical properties of Canadian Athabasca and Cold Lake bitumens.

	Athabasca	Cold Lake
API	8.05	10.71
Viscosity @ 24°C (Pa·s)	323	65
Saturates, wt%	17.27	20.74
Aromatics, wt%	39.70	39.20
Resins, wt%	25.75	24.81
Asphaltenes ^{a)} , wt%	17.28	15.25
Elemental analysis, wt% (Dry basis)		
C	83.34	83.62
H	10.26	10.50
N	0.53	0.45
S	4.64	4.56
O	1.08	0.86
Ash	0.15	0.01

a) Heptane insolubles

Source: S. Peramanu et al., *Molecular Weight and Specific Gravity Distribution for Athabasca and Cold Lake Bitumens and Their Saturates, Aromatics, Resin, and Asphaltene Fractions*, 1999

Table 4-3. Bitumen viscosity comparison of Utah and Canadian Athabasca oil sands.

Origin of oil sand	Bitumen content (wt%)	Bitumen viscosity (Pa·s)	
		50°C	90°C
Whiterocks	7.5	110.0	2.5
Asphalt Ridge	11.5	80.0	1.2
P.R. Spring	11.9	280.0	4.5
Sunnyside	9.5	1500.0	18.0
Athabasca	14.5	5.0	0.2

Source: J. Hupka et al., *Diluent-Assisted Hot-Water Processing of Tar Sands*, 1987

4.2.2 Surface Mining and Processing

Surface mining and processing technologies were specifically developed to exploit large, shallow, unconsolidated deposits of oil sands in western Canada. The only large-scale commercial process in this category is used in Canada to produce about 720,000 BOPD (60% of total Canadian production) [1]. This process involves mining and surface processing by water extraction. At present, pilot-scale and small commercial-scale activities involving mining and solvent extraction are being conducted by Temple Mountain Energy and Earth Energy Resources Inc. in some Utah deposits. A third technology, thermal extraction methods, have been extensively researched but never commercially applied.

4.2.2.1 Surface Mining

The Canadian oil sand surface production operations are massive. To achieve current production levels of 720,000 BOPD, about 1.5 million tons a day of oil sands must be mined and at least an equivalent amount of overburden must be removed [55]. Mining Utah oil sands is more challenging than mining Canadian oil sands because the Utah deposits are lenticular, are located in more rugged and mountainous terrain, and are more consolidated. The consolidated deposits will require milling-type mining equipment in contrast with the shovel-type equipment used in Canada. Additionally, substantial portions of the Utah deposits are deep and not easily accessible.

In lenticular deposits, the rich deposits are often interspersed with lean sands or shales.

Nevertheless, there are two significant advantages in mining Utah oil sands compared with Canadian oil sands. One, the quantity of fines is lower and two, the percentage of sulfur in the bitumen is much lower.

The oil sand particles have a size distribution. The particles in the smallest size range (< 40 micron) are called fines.

4.2.2.2 Hot Water Extraction Process

The water-based bitumen recovery process has evolved steadily over the last 30 years and includes mining, bitumen extraction, separation, reclamation, and upgrading. Canadian oil sands are generally classified in terms of the bitumen content: rich (12-14%), average (10-11%) and lean (6-9%). In general, the richer the quality of the ore, the higher the bitumen recovery.

Approximately 10 units of water are required to obtain 1 unit of bitumen from ore. Since 70% or more of the process water is recycled, approximately 2-3 units of fresh water are required to produce every unit of bitumen [54,56]. A schematic of the bitumen recovery process is shown in Figure 4-5. Each of the unit processes has been developed to improve total bitumen yield and quality.

Process temperature and inorganic additives are major factors in bitumen extraction. At first, commercial oil sands projects were operated at about 167°-176°F (75°-80°C), the Clark Hot Water Process [57], as sharp reductions in bitumen yield were observed at operating temperatures below 122°F (50°C) [58]. Recently, improved knowledge of the separation process has led to a number of process innovations. As a result, commercial hot water extraction processes currently operate at 113°-122°F (45°-50°C).

Figure 4-5. Schematic diagram of a water-based bitumen recovery process.

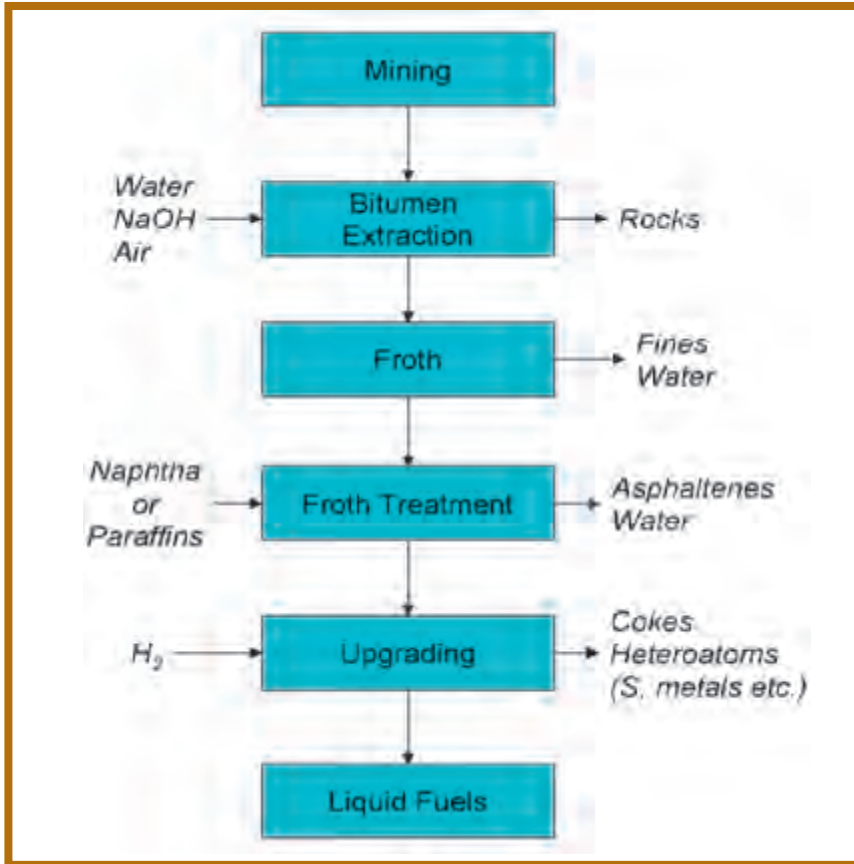

Source: Utah Heavy Oil Program

Maximum bitumen recovery occurs in a weak alkaline environment produced by additives such as sodium hydroxide (NaOH). Organic acids in the bitumen are ionized by NaOH to form surfactants. An alternative to NaOH treatment is the addition of commercial surfactants, which are then recovered from the tailings process. Surfactants play a role in lowering the bitumen-water interfacial tension, allowing bitumen liberation from the oil sands ore as depicted in Figure 4-6. Bitumen liberation consists of bitumen thinning, pinning and forming distinct droplets on the sand grain surface. Further floating and liberation of bitumen results from high temperature engulfing of air inside droplets of bitumen or from low temperature attachment of bitumen droplets to air bubbles as illustrated in Figure 4-6 [7].

Following bitumen extraction is froth treatment and diluent addition as seen in Figure 4-5. Two commercial froth treatment processes, Syncrude and Albion, are operated in Alberta. The Syncrude froth treatment uses naphtha as a diluent. Density differences derived from naphtha addition promote bitumen separation. A centrifuge is used to separate the emulsified water from the solids. This process produces higher bitumen yields but leads to higher water (2 wt%) and higher solids content (0.5 wt%) in the extracted product. The Albion process employs paraffin as a diluent. This process promotes the rejection of water and solids from the bitumen, leading to a lower yield but higher quality product. However, heavier fractions of bitumen are left behind through asphaltene precipitation. A multistage settling process is required for higher bitumen recovery [59,60].

Sodium hydroxide (NaOH) is a caustic base that forms a strong alkaline solution when dissolved in water.

Naptha is an intermediate liquid product of crude oil refining.

Paraffins are saturated hydrocarbons.

H₂ is hydrogen gas.

Bitumen disengagement from the sand is viewed as a three-step process. These types of mechanisms are useful in understanding the fundamentals of the process, leading to process improvement and optimization.

Froth consists of bitumen, water and solids before diluent addition.

Figure 4-6. Bitumen liberation and aeration in water-based extraction process.

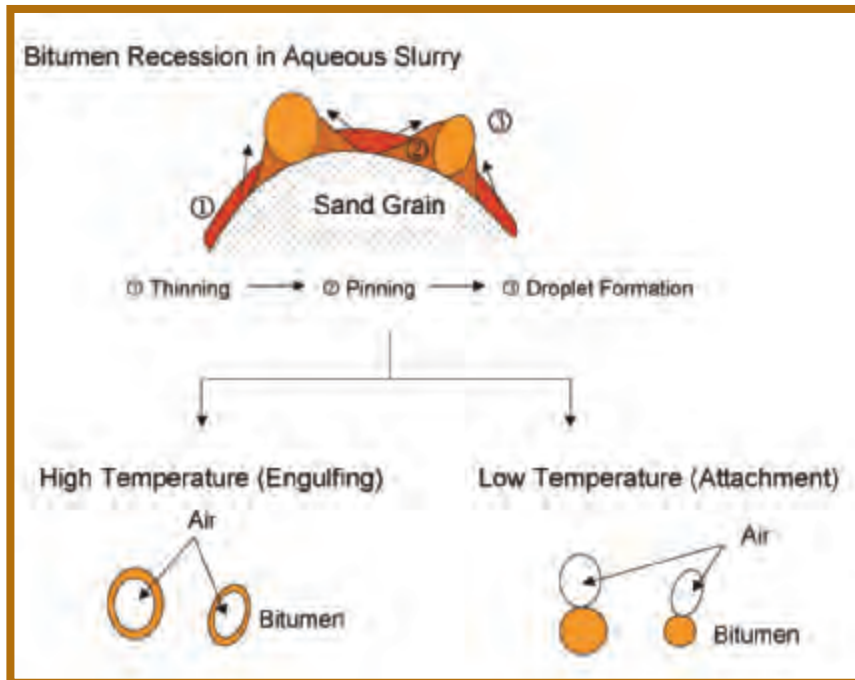

Source: J. Masliyah et al., *Understanding Water-Based Bitumen Extraction from Athabasca Oil Sands*, 2004

The final step in the process, upgrading, is necessary for reduction of bitumen viscosity and sulfur content before refining. Upgrading is discussed in greater detail in Section 5.

4.2.2.3 Water Process for Utah Oil Sands

The Canadian hot water process must be optimized for Utah oil sands due to differences between Canadian and Utah oil sands. In general, Utah oil sands have lower porosity, bitumen content, water content, and clay mineral content and are more consolidated than their Canadian counterpart. In addition, bitumen from Utah oil sands is significantly more viscous than bitumen from Canadian oil sands (see Tables 4-1 and 4-2). Optimal conditions for hot-water extraction have been determined from research specific to Utah oil sands [61,62]. The digestion step involves applying mechanical energy to the oil sands with hot water (194°-203°F/90°-95°C) present. Typically, kerosene or other low boiling point compounds are added as diluents. Sodium hydroxide, sodium silicate, and sodium carbonate are added as wetting agents. Important experimental parameters are bitumen viscosity, water pH, sand particle size distribution, temperature and amount of agitation. The optimum bitumen viscosity for efficient extraction is about 1,000 cP. Optimum wetting agent concentration is required due to ineffective bitumen recovery at low concentrations and emulsification issues at high concentrations. Greater than 90% bitumen recovery can be achieved in an optimized hot-water process [48]. Recent studies by CANMET have confirmed the viscosity limits for hot water extraction of Utah oil sands, operating without solvent addition [63].

Air is also injected in the bitumen-sand separation processes.

4.2.2.4 Solvent Extraction Processes

In a solvent extraction process, a solvent or a mixture of solvents flows countercurrent to mined and crushed oil sand material in a processor. The solvent helps separate the bitumen from the sand. A mixture of solvent and bitumen is separated from the top of the processor, while the sand with remaining bitumen and dissolved solvent is discharged at the bottom. The solvent is separated from the product either by changing pressure and temperature conditions or by distillation. The solvent is separated from the sand using air stripping. The key to the success of the process is solvent recovery. If most of the solvent is recovered and recycled, the process has good potential for economic success.

A number of hydrocarbon solvents have been suggested and used. Paraffinic gaseous solvents (propane and butane) are ideal because solvent separation is easy. However, yields with this type of solvent are usually low (50-60%). Higher molecular weight paraffinic solvents (pentane and hexane) extract bitumen more efficiently but are difficult to separate both from the product and from the sand. For a higher-yielding process, a mixture of solvents is prepared, and the pressure and temperature at which the extraction occurs is optimized.

Two companies, Temple Mountain Energy and Earth Energy Resources Inc., have performed pilot testing in Utah's Asphalt Ridge and PR Springs deposits respectively. The solvents used in these processes have not been publicly disclosed. However, both companies claim very high bitumen recovery (99%+) and good solvent recovery. Based on what has been publicly stated, if the mining costs can be controlled, these processes should be economical [64,65]. If commercial development of Utah oil sands were to occur in the short term, mainly due to surging oil prices, it appears that solvent extraction would be the process of choice.

4.2.2.5 Thermal Cracking

Oil can also be produced from oil sands by heating the sand in a fluidized-bed or in a rotary kiln reactor in an inert atmosphere, a process known as pyrolysis. The reactions take place between about 887°-1067°F (475°-575°C). The oil produced from a pyrolysis process is partially upgraded. Table 4-4 [66] compares properties of bitumen-derived liquids resulting from fluidized bed pyrolysis for several Canadian and United States oil sands. The data show that good quality oil, with over 75% of the liquid fraction boiling below 995°F (535°), can be produced by thermal cracking.

In laboratory studies of the fluidized bed pyrolysis of oil sands for the production of bitumen-derived liquid, the most important process variables were reaction temperature and sands retention time in the pyrolysis zone. Chemical properties such as Conradson carbon residue, atomic H/C ratio, and the asphaltene content of the bitumen correlated well with product distributions and yields, while physical properties such as API gravity and viscosity did not [48]. The coke yields were independent of the operating variables but dependent on the type of oil sands used [48].

Fluidized beds are usually vertical reactors where the crushed sands are fluidized using inert gases like nitrogen. Rotary kilns are large rotating drums into which the oil sands are fed and heated.

An inert atmosphere is a nonreactive gas atmosphere such as nitrogen, carbon dioxide, or helium. There is no oxygen present.

H/C ratio is an indication of the aromaticity of the oil. Paraffinic constituents have a higher H/C ratio than the aromatic constituents. Hydrogen addition is required for upgrading since a higher H/C ratio oil is preferred.

Table 4-4. Properties of bitumen-derived products obtained by thermal fluidized-bed pyrolysis of oil sands.

	Athabasca	Tar Sand Triangle	Asphalt Ridge	PR Spring	Wilmington*
Gases (< C5)	7.52	5.31	4.80	7.41	6.03
Liquid Condensate (< 535°C)	76.52	72.82	82.85	76.05	77.04
Coke	15.96	21.87	12.35	15.54	16.93
Liquid condensate properties					
C, wt%	84.7	85.2	87.1	86.5	86.5
H, wt%	11.3	11.6	12.0	12.1	11.7
N, wt%	0.19	0.16	0.58	0.57	0.43
S, wt%	3.75	2.68	0.32	0.29	1.43
O, wt%	0-trace	0-trace	0-trace	0-trace	0-trace
Ave. MW	279	280	282	280	313
S.G. (20/20)	0.923	0.910	0.898	0.895	0.920
API	21.9	24.0	25.8	26.5	22.3
Heating value, MJ/kg (BTU/lb)	42.85 (18,632)	43.25 (18,803)	43.89 (19,084)	44.05 (19,153)	43.70 (19,002)
Coke analysis					
C, wt%	88.6	87.7	87.9	87.7	89.8
H, wt%	2.5	2.8	3.0	2.6	2.9
N, wt%	1.8	1.5	2.9	2.9	3.0
S, wt%	6.0	6.2	0.4	0.5	1.5
O, wt%	N/A	N/A	N/A	N/A	N/A
Heating value, MJ/kg (BTU/lb)	34.41 (14,960)	34.39 (14,950)	34.18 (14,860)	32.59 (14,170)	34.88 (15,165)

*Petroleum residue after atmospheric distillation from the Wilmington Field, California.

When oil sands are thermally treated, gaseous products are released due to the cracking of oil molecules. These volatile products are condensed to form the liquid condensate.

Source: J.W. Bunger et al., *Processing of Tar Sand Bitumens, Part I, Thermal Cracking of Utah and Athabasca Tar Sand Bitumens*, 1976

Thermal pyrolysis in a rotary kiln has been explored at the laboratory scale and proven to be a feasible alternative to fluidized bed pyrolysis [67]. Contact between gases and solids in a heterogeneous gas-solid reaction is the greatest advantage of a rotary kiln. The liquid product from the rotary kiln is significantly upgraded and would be an excellent refinery feedstock. In laboratory research, temperature and retention time were the two most important variables in liquid (C5+) and gas (C1-C4) yields. At a fixed solid retention time, increases in reaction temperature resulted in a decreased liquid product yield, a significantly increased light gas yield, and a slightly reduced coke yield. At a fixed temperature, decreases in retention time resulted in an increased liquid product yield, a decreased gas yield, and relatively unchanged coke yield [67].

C5+ refers to components boiling at or above the boiling point of pentane. These compounds are liquids at room temperature and pressure.

Hydrocarbons from methane (C1) to butane (C4) are gases at room temperature and pressure.

The obstacles to the commercialization of this technology are the substantial energy requirements as the sands have to be crushed and heated to target temperatures of about 1022°F (550°C), the cleanup of produced oil (e.g. removal of sand and other solid contaminants), and the disposal considerations of sand contaminated with small quantities of residual oil. In fact, the major technical hurdles for producing oil from oil sands by ex situ thermal technologies are similar to the obstacles observed for ex situ production of oil from oil shale.

4.2.3 In Situ Processes

In situ processes for bitumen production from oil sands are used when there is substantial overburden and when the formation has good seals at the top and the bottom. In situ methods are basically extensions of the EOR technologies for the production of heavy oils. In Canada, in situ processes account for about 40% of the total production of 1.2 million BOPD in the form of bitumen [1]. Some of the in situ production is carried out by primary production methods, e.g. pressure depletion. In 2004, primary production accounted for about 30% of the total production [68]. Other than primary production, the two most common in situ processes for bitumen extraction are cyclic steam stimulation and SAGD. A large portion of the enhanced recovery production is from the cyclic steam operations of Imperial Oil in Cold Lake. SAGD production is distributed in Cold Lake, Peace River and Athabasca with the involvement of companies like Encana, Petrocanada, Shell Canada, Canadian Natural Resources, Devon and Nexen.

These and other in situ processes are reviewed briefly below. In situ methods ought to be carefully considered for Utah oil sands because of the lenticular nature of the deposits and the fact that the deposits are not as rich and thick as the Canadian deposits. These resource characteristics imply that in situ processing of Utah oil sands will require considerably more energy than a comparable process in Canada as energy will be wasted in heating non-oil-bearing layers. One advantage of in situ methods in the arid western United States is that water consumption may be considerably less than that for surface extraction methods. Water requirements reported for in situ operations are 3 units of water in the form of steam per unit of bitumen produced [69]. Most of the process water is recycled, resulting in values as low as 0.2 units of fresh water required per unit of bitumen produced [54,56,59].

4.2.3.1 Cyclic Steam Stimulation and Related Methods

Cyclic steam stimulation (CSS) is the simplest and the most direct of the in situ methods. Steam is injected at high pressures into the subsurface and allowed to soak. The pressure dilates or fractures the formations, and the heat reduces the viscosity of the bitumen. The bitumen is then pumped to the surface through the same injection well. The process is repeated in a cyclical fashion. A schematic of the CSS process, shown in Figure 4-7, illustrates the three stages of CSS: injection, soak and production [70]. This process only recovers about 15-20% of OOIP. However, CSS could be combined with another in situ method to recover the remaining bitumen. In one variation of the process, cyclic steam stimulation is performed in a pattern [71]. CSS is currently being applied in several Canadian operations with more than one-third of the total in situ production in Canada coming from cyclic steam processes.

CSS is commonly known as 'huff-and-puff'.

Figure 4-7. Schematic of a cyclic steam stimulation process showing injection, soak and production.

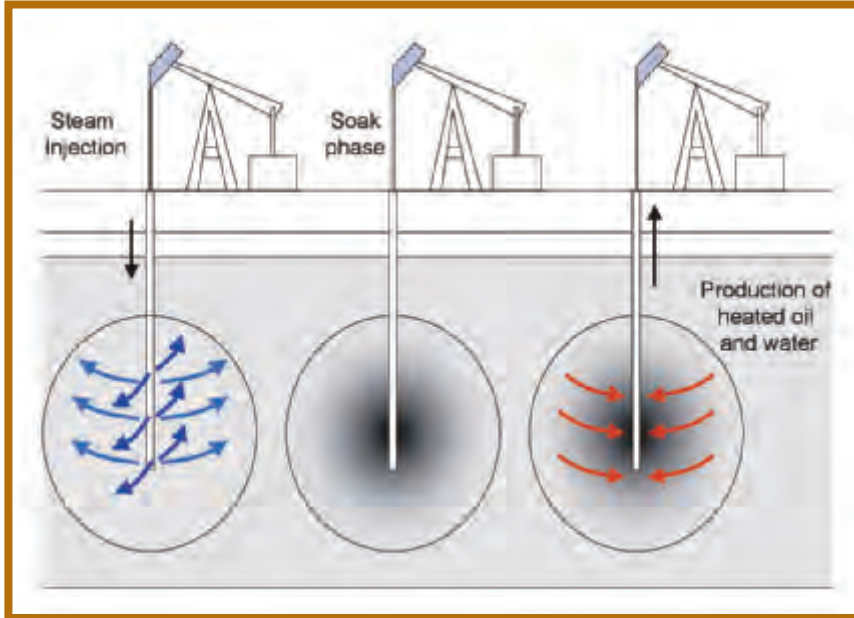

Source: R. F. Meldau et al., *Cyclic Gas/Steam Stimulation of Heavy Oils*, 1981

The Liquid Addition to Steam for Enhancing Recovery (LASER) method is an improvement on the CSS method. Liquid hydrocarbons (C5+) are injected with the steam into the subsurface, followed by soaking and pumping. Initial laboratory tests have shown promising results, and field tests have been conducted with results surpassing laboratory expectations [72]. This process has shown the ability to increase the production of the CSS process by as much as 33%, from 15-20% to 20-26%.

4.2.3.2 Steam Assisted Gravity Drainage

SAGD has become the dominant technology employed in a variety of heavy oil and bitumen recovery processes because it utilizes the natural tendency of oil to drain by gravity into production wells. It is a relatively simple process to implement and with an SOR of 3 to 1, the most commonly reported SOR for operations in Canada, it is efficient and profitable at current crude oil prices [68,69]. Canadian development leads the way; a number of oil companies are currently involved in pilot and commercial applications of the SAGD process, including Encana and Petro-Canada as noted previously.

In SAGD, two horizontal wells are placed near the bottom of a formation as shown in Figure 4-8. The length of these horizontal wells can extend up to 3280 feet (1000 meters). One well is used to inject steam, which, due to buoyant forces, rises through the formation to create a steam chamber near the top of the formation. Steam mobilizes the bitumen which then flows downward. The production well, placed about 16 feet (5 meters) below the injection well, is used to collect the resulting condensate and the released oil. Oil is easily separated from the produced emulsion by blending with condensate and treating with chemicals at elevated temperatures. Water and gas produced from the well are recycled. Recoveries of 50% of OOIP are possible, although reported recoveries are in the range of 20% [53], possibly due to reservoir

Condensate refers to injected steam that gives up its heat in the reservoir and condenses to water.

architecture and heterogeneities. Long horizontal well segments have the potential for higher oil recovery rates.

A variation of this technology, the ES (expanding solvent)-SAGD process, injects a dissolved hydrocarbon with the steam and thereby reduces the water and energy requirements while increasing yield [53].

Figure 4-8. Illustration of the SAGD process including the horizontal injector, the horizontal producer, and some surface facilities.

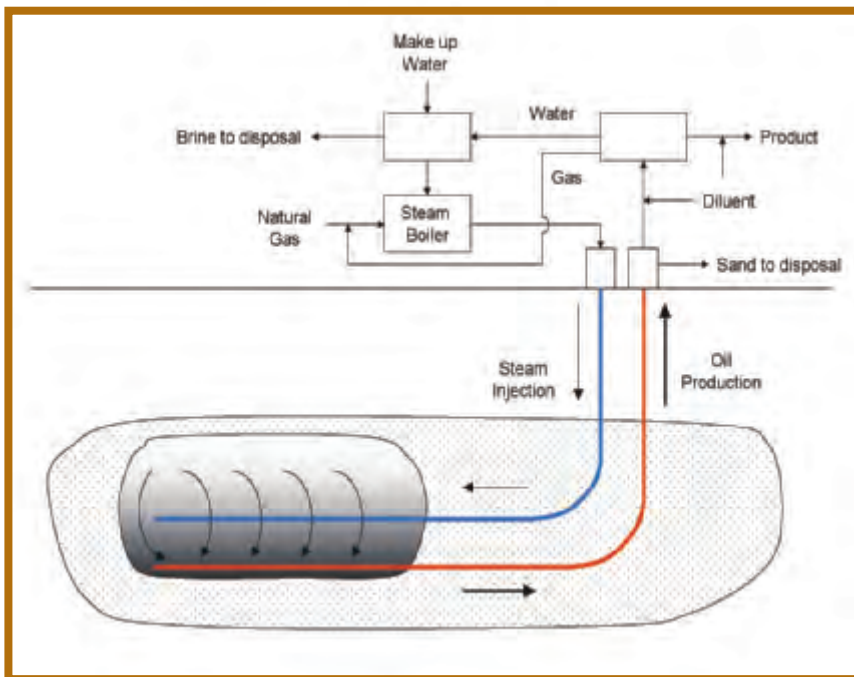

Source: Utah Heavy Oil Program

4.2.3.3 Vapor Extraction

Vapor Extraction (VAPEX) is a non-thermal process similar to the SAGD process. Instead of steam, a vaporized hydrocarbon is injected into the bitumen reservoir. The hydrocarbon diffuses into the bitumen and reduces its viscosity, thus allowing the oil to flow to a horizontal collector well. The advantage of the VAPEX process over SAGD is that the injected hydrocarbon may partially upgrade the oil through deasphalting. Nevertheless, the reported recoveries of 5% or less of OOIP are very low compared to the SAGD process [53,73].

Deasphalting is a process in which the heavier portion of the crude oil (asphaltenes) are precipitated and removed from the oil.

4.2.3.4 Steamflooding

The steamflooding process for bitumen recovery from oil sands mirrors the steamflooding process for heavy oil described in section 4.2 and is similar to the CSS process discussed above. Steam, continuously injected into the subsurface bitumen reservoir through vertical injectors, drives the oil towards a vertical producer. Recently, both horizontal and vertical shafts have been used for the injection. This process has recovered up to 50% of OOIP. However, its thermal efficiency is lower than that of other in situ processes with an SOR of 5. Although the steamflooding process has been successfully applied in California and in Venezuela for heavy oil production, it has met with limited success for Canadian bitumen production due to the low initial mobility of the

bitumen [74]. Nevertheless, as the CSS and SAGD steam processes mature, efficient steamflooding methods will have to be devised for additional bitumen production.

4.2.3.5 In Situ Combustion

In situ combustion relies on heat generation within the reservoir to reduce bitumen viscosity. Heat is generated by first injecting air and then igniting the air/bitumen mixture to produce a combustion zone. The heat of combustion causes the flow of the remaining bitumen to a horizontal collector. This bitumen flow is driven by a combination of steam, hot water, and combustion gases. Despite the relatively high efficiency of in situ combustion and the elimination of the equipment and energy requirements of steam production, it has not been widely accepted. Instead, in situ combustion has been plagued with technical difficulties including an inability to control the fire front, the possibility of well connectivity and resulting well damage, high corrosion rates, and emulsions that form and are difficult to break [75].

Water is often injected to improve heat transfer from the reservoir behind the combustion zone to the reservoir in front of the combustion zone.

Many of these difficulties are now being resolved. A variation on this method, the Toe-to-Heel-Air-Injection (THAI) method has met with some success [76]. A schematic of the THAI process is shown in Figure 4-9 [77]. In this process, a vertical injection well is used to inject air and initiate combustion. The heaviest organic molecules are combusted and heated oil drains toward a horizontal production well. Notwithstanding the claims made about the THAI process, the first field pilot has yet to be completed; air injection began part way through 2006. In practice, this pilot required extensive steam injection before the air could be introduced [77].

Figure 4-9. Schematic of the THAI Process.

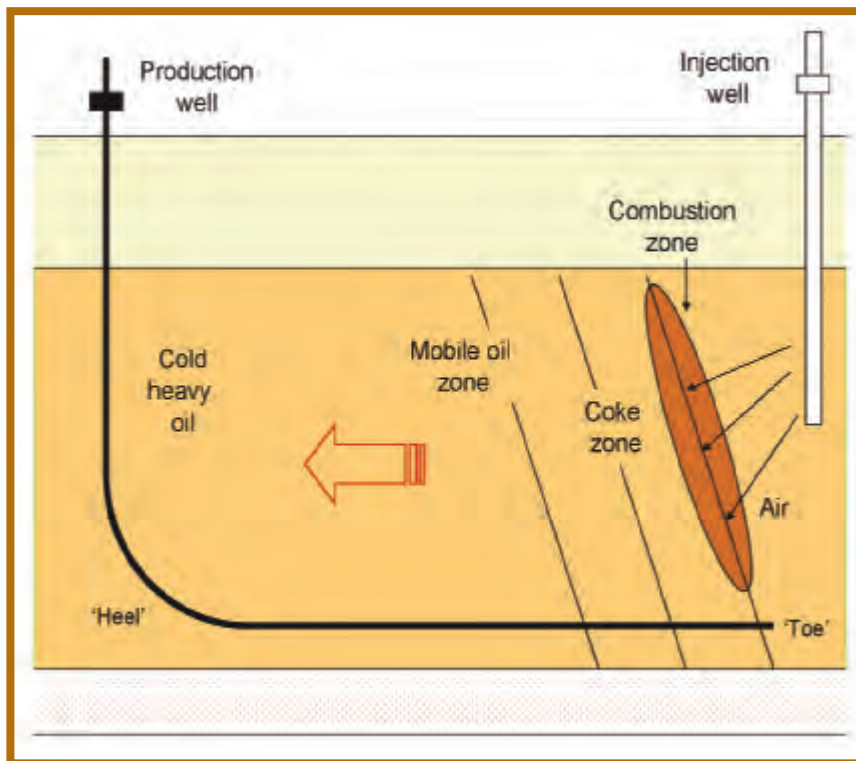

Source: Petrobank Energy and Resources, Ltd., THAI Technology, 2007

4.3 Production Processes for Oil Shale

Oil shale is commonly defined as a fine-grained sedimentary rock bound with organic material known as kerogen (see Section 3). The organic and the inorganic matter are inextricably combined. All known processes for disengaging the kerogen from the inorganic matrix and for converting the kerogen to oil require heat input. The organic matter is released under a wide variety of conditions including heating times that range from seconds to months, ambient or elevated pressures, gaseous or solid heat transfer mediums, and heat transfer by conduction, convection, or radiation [5,6].

Production processes for the thermal treatment of oil shale deposits fall into the same categories as oil sands production processes: (1) surface mining and processing (ex situ production) and (2) in situ production methods. In the first option, oil shale is mined, crushed, and then subjected to thermal processing at the surface in an oil shale retort. Both pyrolysis and combustion have been used to treat oil shale in a surface retort. In the second option, the shale is left in place and the retorting (e.g. heating) of the shale occurs in the ground. This process can be achieved via direct heating or by performing in situ combustion.

A generalized extraction and oil production schematic for oil shale, including both mining/surface processing and in situ processing options, is shown in Figure 4-10. Within each process unit, several alternative techniques are included. Expected liquid products and by-products are also shown. The most significant technologies, including descriptions of the process units involved, are discussed in this section.

A retort is a piece of process equipment where materials are heated to high temperatures in the presence or absence of air. If the shale is heated in an inert atmosphere, the process is called pyrolysis. If the shale is heated and reacts with air, the process is called combustion.

Figure 4-10. Generalized processes for conversion of shale to fuels and byproducts.

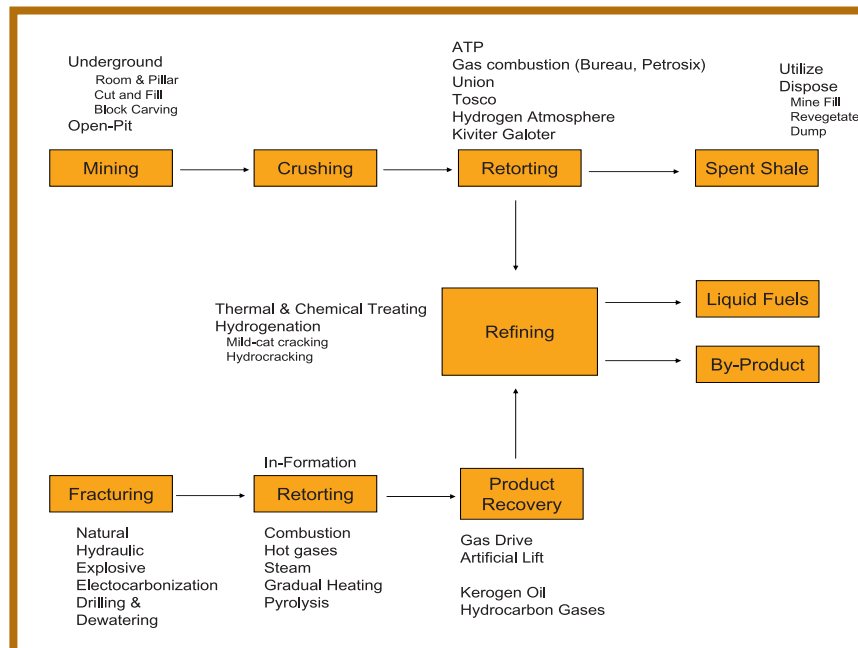

Source: H.R. Johnson et al, Strategic Significance of America's Oil Shale Resource: Volume II, Oil Shale Resources, Technology and Economics, March 2004

Despite the technical progress that has been made in oil shale processing since the last oil shale boom in the 1970s, there are still major obstacles in the path of oil shale commercialization. These include the high initial capital investments, the possible instability of world crude oil prices, the lack of a clearly defined federal oil shale development policy, and environmental considerations [5,6,78].

4.3.1 Chemical Nature of Oil Shale

Generally speaking, the precursors of the organic matter in oil shale and coal are different. Much of the organic matter in oil shale is of algal origin but may also include the remains of vascular land plants which more commonly comprise the organic matter in coal. The origin of some of the organic matter in oil shale is enigmatic because of the lack of recognizable biological structures that would help identify the precursor organisms. Such materials may be of bacterial origin or the product of bacterial degradation of algae or other organic matter [79].

Mineral and elemental composition differentiates coal from oil shale. First, oil shales typically contain much larger amounts of mineral matter (60–90%) than do coals (less than 40%). Second, the organic matter in oil shale usually has a higher oxygen to carbon (O/C) ratio than that of coal. As kerogen undergoes diagenesis, the O/C ratio decreases and carbon dioxide and water are released [80]. To contrast to O/C ratios, H/C ratios for oil shale, coal, and oil shale are all comparable. Third, the heating value of coal, which ranges from 14.7–19.2 MJ/kg on a dry basis [81], is generally higher than that of oil shale, with higher heating values ranging from 2.1–16.8 MJ/kg on a dry basis. The Estonian kukersite oil shale, with higher heating values in the range of 8.4–9.2 MJ/kg, is used as a fuel for several power plants. By comparison, Colorado and Utah oil shales have heating values of about 8 MJ/kg.

Table 4-5 presents physical and chemical properties, including carbon, hydrogen, nitrogen, and sulfur content, of some western United States oil shales designated as reference shales by the U.S. Department of Energy [82]. The table gives the composition of the raw shale, including ash content and weight percent of mineral carbon, organic carbon (C), hydrogen (H), nitrogen (N), and sulfur (S). Oxygen can be inferred by difference. For the Colorado reference shale, the ash content is 66.9% by weight, mineral carbon is 4.2% by weight, and the elemental analysis by weight is C - 18.0%, H - 1.9%, N - 0.6%, and S - 1.3%. For this shale, oxygen content is 7.1% by weight as computed by difference. The table also gives the composition of the shale in terms of its recoverable resources, oil and gas. For the Colorado reference shale, 10.24% of the oil shale by weight can be recovered as oil while 4.6% can be recovered as gas. The byproducts of this recovery are spent shale and water, which are 83.5% and 1.62% by weight of the original shale, respectively.

Diagenesis is the physical, chemical or biological alteration of sediments into sedimentary rock at subsurface temperatures and pressures. As a result of this process, complicated structures inherited from living organisms are reduced to simple, stable molecules [80].

MJ/kg is an SI unit of energy density (energy stored in coal/kerogen per unit mass). MJ is 1,000 Joules.

Table 4-5. Material balance and Fisher Assay results for reference shales.

Product	Wt%	Gal/ton	%Ash	Mineral Carbon wt%	C, wt%	H, wt%	N, wt%	S, wt%
Colorado Reference Oil Shale								
Oil	10.24	27.50	-	-	83.2	12.2	1.7	0.7
Gas	4.60	-	-	-	41.4	7.0	-	4.8
Spent shale	83.50	-	78.63	4.9	8.8	0.2	0.5	1.1
Water	1.62	3.88	-	-	-	11.1	-	-
Raw Shale	100.0	-	66.90	4.2	18.0	1.9	0.6	1.3
% Recovery	99.96	-	98.14	97.42	98.8	101.4	89.7	94.1
Kentucky Reference Oil Shale								
Oil	5.67	14.38	-	-	84.5	10.6	1.2	1.6
Gas	3.16	-	-	-	39.5	12.4	-	40.5
Spent shale	89.54	-	87.12	0.22	8.7	0.4	0.9	4.5
Water	1.20	2.87	-	-	-	11.1	-	-
Raw Shale	100.0	-	78.38	0.25	13.9	1.4	0.4	5.8
% Recovery	99.57	-	99.52	78.8	99.7	104.9	114.1	92.6
Wyoming Reference Oil Shale								
Oil	8.84	22.03	-	-	81.6	10.9	2.1	0.5
Gas	2.09	-	-	-	42.9	9.1	-	0.1
Spent shale	85.96	-	81.33	3.7	7.7	0.3	0.5	0.4
Water	3.15	7.56	-	-	-	11.1	-	-
Raw Shale	100.0	-	71.23	3.4	14.97	1.4	0.6	0.4
% Recovery	100.04	-	98.15	93.50	98.40	129.0	102.60	97.5

The quality of shale is quantified by measuring gallons of oil produced from a ton of raw shale.

Source: K.J. Bird, *North American Fossil Fuels, The Geology of North America - An Overview, 1989*

For some oil shales, the mineral component is predominantly carbonate minerals including calcite, dolomite, and siderite, with lesser amounts of aluminosilicate minerals. For other oil shales, the reverse is true – silicate minerals including quartz, feldspar, and clay minerals are dominant, whereas carbonate minerals are a minor component. Many deposits of oil shale contain small but ubiquitous amounts of sulfide minerals including pyrite and marcasite. The mineral composition of the Rifle field in Colorado is shown in Table 4-6. It is predominantly carbonate minerals with no sulfide content. Also included in Table 4-6 is the elemental composition of the kerogen component of the oil shale [83].

Table 4-6. Average chemical and elemental compositions of several oil shale samples from Rifle, Colorado in the Green River Formation.

Matter	Composition	Wt% (Dry basis)	Element	Wt%
Mineral Matter 86.2 %	FeS ₂	0.86		
	NaAlSi ₃ O ₆ ·H ₂ O (analcite)	4.3		
	SiO ₂ (quartz)	8.6		
	KAl ₄ Si ₇ AlO ₂₀ (OH) ₄ (illite) montmorillonite muscovite	12.9	-	-
	KAlSi ₃ O ₈ (K-feldspar) NaAlSi ₃ O ₈ -CaAl ₂ Si ₂ O ₈ (plagioclase)	16.4		
	CaMg(CO ₃) ₂ (dolomite) and calcite	43.1	C	5.6
		O	22.2	
		Ca	9.5	
		Mg	5.8	
Organic Matter 13.8 %	Kerogen	11.04	C	11.1
	Bitumen	2.76	H	1.42
			S, N, O	1.28

Source: T.F. Yen and G.V. Chilingar, *Introduction to Oil Shales*, 1976

4.3.2 Surface Mining and Retorting

Oil shale can be produced through traditional mining methods, including underground mining (room-and-pillar method) or surface mining (open-pit). One criterion for choosing a method is the depth at which the oil shale deposit is located. The room-and-pillar method has produced 60% recovery of OOIP in seams less than 100 feet (30 meters) thick, but in larger seams recovery may drop to 10%. Higher efficiencies can be obtained with surface mining, but the overburden is so thick and the deposits so large in the western United States that the mines would be comparable to the largest open-pit mines in the world [78,84].

In room-and-pillar mining, some oil shale is removed to form large rooms and some is left in place as pillars to support the mine roof [70].

Once the oil shale has been mined, the ore is crushed and retorted. Surface retorting processes are divided into three main types: indirect retorting, direct retorting, and a combination of the two. In indirect retorting, pyrolysis is driven by the transfer of sensible heat from a heat carrier to the oil shale. These heat carriers are heated separately from the oil shale, recycled or recirculated through the bed of oil shale, and then passed back through the heater. In direct retorting, shale gas is partially recycled into the bottom of the process vessel where it moves upward, countercurrent to the crushed shale. Combustion of shale gas with air heats the shale to retorting temperatures due to direct countercurrent contact between the hot gas and the oil shale [85]. A third type of retorting, the Alberta Taciuk Process (ATP), is a combination of the indirect and direct retorting processes [86]. Several retorting technologies are discussed in greater detail in the next sections.

A heat carrier can be a solid material such as ceramic balls or a recycle gas.

During retorting, kerogen decomposes into three organic fractions: oil, gas and residual carbon. Oil shale decomposition begins at relatively low retort temperatures (572°F/300°C) but proceeds more rapidly and more completely at higher temperatures. The highest rate of kerogen decomposition occurs at retort temperatures of 896°-968°F (480°-520°C) [87]. Most conventional retorts are operated in or near this temperature range. In general, oil yield decreases, retort gas yield increases, and the aromaticity of the oil increases with increasing retort temperature [85]. There is an upper limit on optimal retorting temperature as the mineral content of the shale may decompose if the temperature rises too high. For example, the predominant mineral component of Estonian kukersite shales is calcium carbonate, a compound that dissociates at high temperatures (1112°-1382°F/600°-750°C for dolomite, 1112°-1652°F/600°-900°C for calcite). Carbon dioxide is a product of decomposition and dilutes the off-gases produced from the retorting process [87]. The gases and vapors leaving the retort are cooled to condense the reaction products, including oils and water. The shale oil produced from the retort is partially upgraded and is an appropriate feedstock for the existing U.S. oil refining infrastructure, comparable to a light, sweet crude oil.

Following retorting and shale oil removal, the parent rock must be cooled and treated for disposal. Spent shale disposal, along with the environmental degradation that comes with mining the ore, are two principal environmental concerns that accompany oil shale development. A high yield deposit of oil shale will yield 25 gallons (0.60 barrels) of oil per ton (0.91 metric tons) of material. Thus, in order to meet one quarter of the U.S. demand of 20 million BOPD, about 8 million tons (7.3 metric tons) of ore would need to be mined daily. The quantity of the resulting spent shale would be massive, with large-scale reclamation an issue of concern [78,84].

A metric ton is 1000 kilograms.

Other disadvantages of surface retorting include the energy requirements for achieving the desired quantity and quality of shale oil and of gas; the formation of undesirable organic products, including known carcinogens, in high-temperature retorts; the large volume of hydrogen required for upgrading the shale oil; and the potential for leaching carcinogens and heavy metals into groundwater reservoirs from spent shale disposal.

The main advantage of mining and surface retorting is that the material can be treated at the surface in a controlled manner to obtain the desired product. If surface mining techniques are used, relatively shallow deposits have to be mined. The Canadian oil sands operations have demonstrated that the efficiency of mining operations improves at larger scales; see Section 6.1.2.

Large scale processing of mined oil shale has not been explored in the United States in the past 20 years. During this time, significant advances have been made in the fields of process design and control, simulation/modeling, separation and purification, and environmental impact reduction. Pilot plants implementing new technologies for oil shale processing would need to be built to test the viability of this production method.

4.3.2.1 Indirect Retorting

The Tosco II process, shown in Figure 4-11 [84], was initiated in the 1960s and 1970s. Retorting is accomplished in a pyrolysis drum, also known as a rotary kiln, where externally heated ceramic balls, 15 millimeters in diameter, are mixed with preheated shale that has been crushed to a size of less than 12 millimeters. The balls are separated from the hot, spent shale on a trommel and re-circulated through a ball heater. The products are drawn off to a collection system for removal of dust and recovery of liquids and gases. This process utilizes all the shale that is mined, has good heat transfer in the solid-to-solid system, and gives yields of 90%. However, the process is complex and requires appreciable quantities of water to condense the liquid products and to prevent dusting of the finely-divided spent shale [84].

A pilot plant designed to handle 1,000 tons (907 metric tons) of mined shale per day was operated over a period of several years ending in April 1972. This plant was located on Parachute Creek, Colorado, and was operated by the Colony Development group with Atlantic Richfield Oil Company acting as manager for the group. When the testing program was terminated, Atlantic Richfield announced that data evaluation would require some time before a decision could be made on the construction of a commercial plant processing on the order of 70,000 tons (63,500 metric tons) of shale per day [84,85]. No decision was ever announced and the project was abandoned when oil prices collapsed.

Other group members included Standard Oil Company of Ohio, The Shale Corporation, and Cleveland Cliffs Iron Company.

Figure 4-11. TOSCO II process.

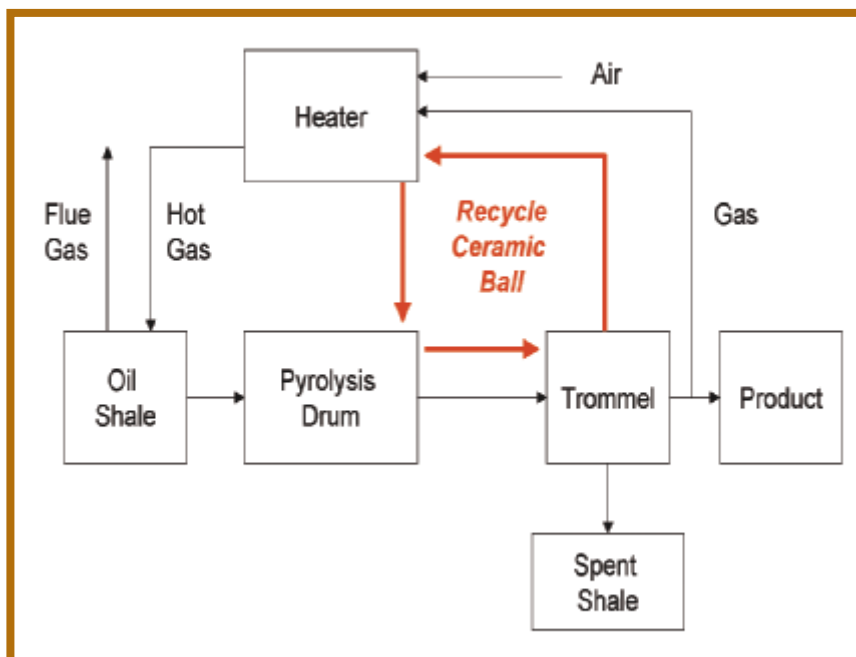

Source: U.S. Office of Technology Assessment, *An Assessment of Oil Shale Technology, Volume I*, 1980

4.3.2.2 Direct Retorting

The gas combustion (e.g. direct) retorting process, shown in Figure 4-12 [84], uses a vertical, refractory-lined vessel through which crushed shale moves downward by gravity, countercurrent to the retorting gases. Recycled gases enter the bottom of the retort and are heated by the hot, spent shale as they pass upward through the vessel. Air and some additional recycle gas are injected into the retort through a distributor system located above the heat recovery zone as seen in Figure 4-12, mixing with the rising hot recycled gases. Combustion of the gases and of some residual carbon heats the shale immediately above the combustion zone to retorting temperature. Oil vapors and gases are cooled by the incoming shale, and the oil leaves the top of the retort as a mist [84].

The benefits of this system include (1) high thermal efficiencies because energy is recovered from the retorted shale and (2) no cooling water requirements, an important consideration in the arid western region of the United States. The main disadvantage of a direct retort is that recovery efficiencies (80-90%) are lower than in indirect retorting [84].

The U.S. Bureau of Mines developed and tested this retorting system during the 1980s specifically for the Green River Shale Formation. The technology was based on then existing coal gasification technologies. However, the project was terminated prior to the operation of the largest of three pilot plants [84,85].

Figure 4-12. Gas combustion retorting process.

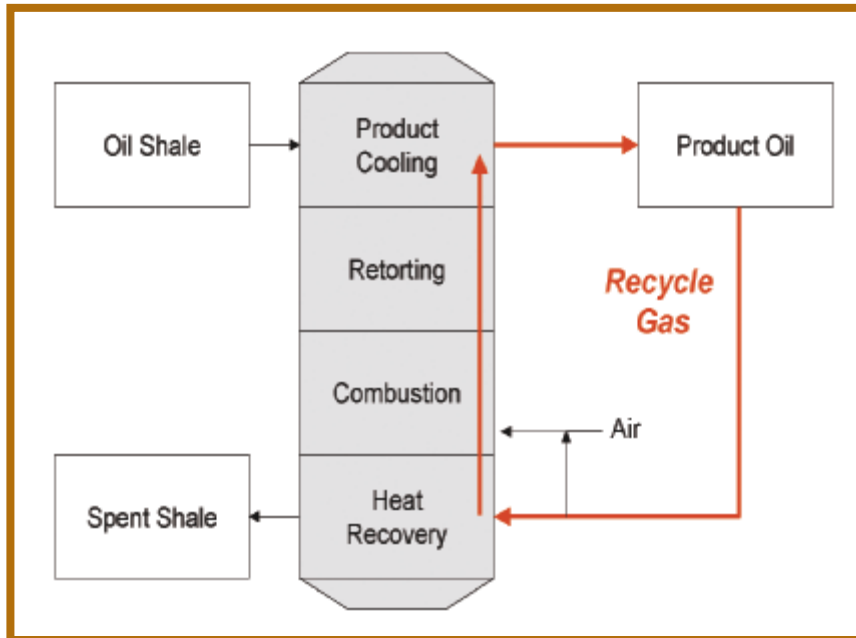

Source: U.S. Office of Technology Assessment, *An Assessment of Oil Shale Technology, Volume I*, 1980

4.3.2.3 Alberta Taciuk Processor

The Alberta Taciuk Processor (ATP) was originally designed to extract bitumen from oil sands but has found application in oil shale processing [86,88,89]. Presently, this retorting technology is used in Australia to process oil shale deposits found in Central Queensland. A schematic of the ATP is shown in Figure 4-13 [86,89]. The rotary

Refractory is a high melting point material that lines furnaces.

In a well integrated process, about 30% of the energy from raw shale is sufficient to support the process energy requirements.

With ATP technology, about 20% of the energy from raw shale is sufficient to support the process energy requirements.

kiln retort combines direct and indirect heat transfer through recirculation of gas and of hot solids. Some of the processed shale is mixed with the fresh feed to provide the energy, through solid-to-solid heat transfer, for combustion and retorting. This technology improves on previously explored retorting methods by increasing oil and gas yields, improving thermal efficiency, reducing process water use, and minimizing the residual coke on the spent shale. The system has been designed to reduce both gaseous and particulate emissions and to make disposal of the spent shale straightforward and efficient.

The Australian Stuart project implemented the ATP technology in a multi-stage strategy. The ATP technology was chosen because of its “simple, robust design; energy self-sufficient process; minimal process water requirements; ability to handle fines; and its high kerogen oil yields” [6]. In stage one, the production level was 4,500 BOPD. Stage one produced 1.3 million barrels between 1999 and 2004. By stage three, production levels were projected to be 200,000 BOPD [88]. However, the ATP processor achieved only 55% capacity in a sustained trial due to mechanical problems and plugging by fine solids. The project was stopped in late 2004 for the further evaluation and the operation subsequently went out of business [90].

Figure 4-13. Alberta Taciuk Process system.

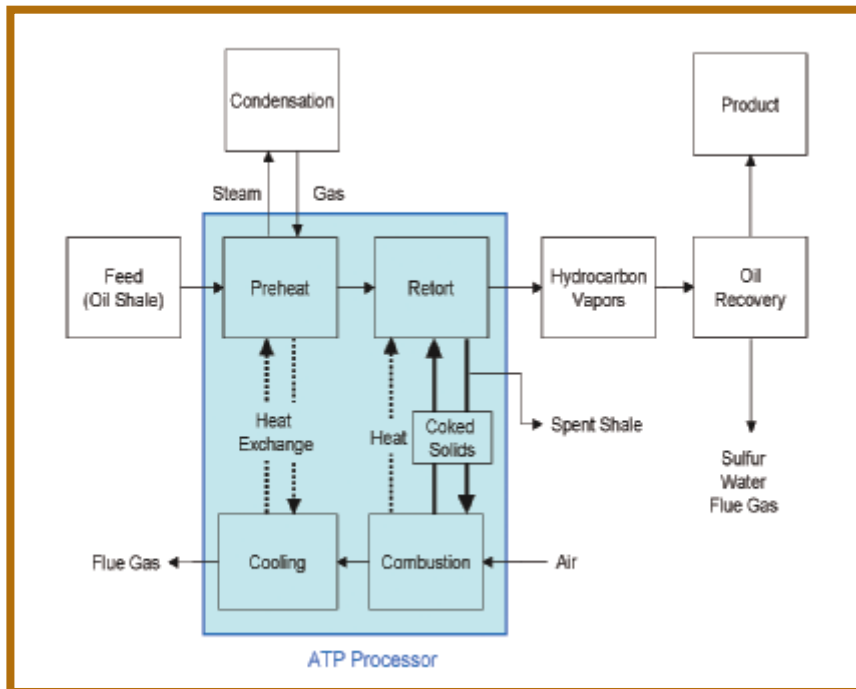

Source: R. Koszarycz et al., *The AOSTRA Taciuk Processing-Heading into the Commercialization Phase, 1991; UMA, UMATAC and the Alberta Taciuk Process, 2006*

The ATP technology has not been tested and demonstrated on western U.S. oil shale reserves and there is uncertainty regarding the use of ATP technology domestically due to the different composition of Colorado shale relative to the Australian shale [6]. Another potential difficulty in applying ATP technology is that Colorado oil shales will generate more fine particles than Australian shale [91]. However, other researchers have concluded that due to their richness, Colorado oil shales will be easier to process using ATP technology with some process modifications [92]. A pilot-scale facility will be necessary to resolved the debate.

4.3.3 In Situ Retorting

In situ retorting during the 1970s and 1980s oil shale boom involved dewatering to remove any groundwater, fracturing the deposit to increase permeability to fluid flow, heating the oil shale in place by injecting a hot fluid or by igniting a portion of the deposit, recovering any oil and gases produced from the heated deposit through wells, and transporting the liquid to an upgrading facility [84]. The most widely tested in situ retorting technology involved burning a portion of the shale underground to provide the heat necessary to retort the remaining shale. This method achieved little success due to temperature and combustion instabilities [78,84].

In a modified in situ retorting method, a portion of the underground shale was mined and then the remaining portion was crushed through a series of explosions. This method overcame many of the difficulties of burning shale underground by allowing the necessary combustion air to permeate the crushed shale. The underground shale was then retorted in place and the mined shale was sent to surface retorts for processing. There were several companies interested in this technology in the early 1980s, but that interest faltered when oil prices collapsed [78,84].

4.3.3.1 In Situ Conversion Process

In the early 1980s, Shell proposed the ICP methodology for in situ retorting. Their process is comprised of a series of underground heaters drilled into an oil shale deposit. The field size for this method is generally one square mile (2.6 square kilometers). Approximately 15 to 25 holes are drilled per acre at a distance of 35-42 feet (10.7-12.8 meters) apart in a variety of configurations. The wells reach a depth of up to 2000 feet (610 meters), depending on the deposit location [78]. The target depth zone is 1000-2000 feet (305-610 meters). A schematic representation of the process can be found in Figure 4-14 [91,94]. In comparing the ICP technology to the generalized schematic of oil shale processes in Figure 4-10, the “Fracturing” step is achieved by existing and induced fractures. Fracturing increases shale permeability [93].

The electrical resistance heaters inserted into the holes reach temperatures of 1400°F (760°C) in order to raise the surrounding shale deposit to an average temperature of 650°-700°F (343°-371°C) [94]. Although this temperature is significantly lower than that required for conventional surface retorting (900°-1000°F/482°-538°C), it is sufficient to induce the chemical and physical changes that release the oil from the shale.

After heating the deposit for 2-3 years, the oil and any associated gas are pumped out of the ground using conventional methods [78]. The hydrocarbon mixture generated from this procedure is of a very high quality and quite different from traditional crude oils in that it contains light hydrocarbons and almost no heavy ends. The mixture quality can be controlled by adjustment of the heating time, temperature and pressure in the subsurface shale layer. A typical mixture is two-thirds liquid (30% naphtha, 30% jet fuel, 30% diesel and 10% heavier oil) and one-third gas (propane and butane). The liquid hydrocarbon fractions can easily be converted into a variety of finished products, including gasoline, naphtha, jet fuel and diesel [91,94]. On a 30 x 40 foot (9.1 x 12.2 meter) test area, Shell recovered 1,700 barrels of light oil “plus associated gas from shallower, less-concentrated oil shale layers” [94].

To protect groundwater, a freeze wall is constructed around the heating grid at a distance of 300 feet (91 meters) from the heaters. The coolant is a 40% ammonia-

water mixture. The freeze wall establishes an underground barrier to fluid movement, thus preventing groundwater contamination and the escape of the freed shale oil [94]. This method of creating an ice barrier has been successfully employed in other mining operation. Shell is planning a test of the freeze wall technology in 2007 on a 25-acre (0.10 square kilometer) parcel of their Rio Blanco County, Colorado property. They have drilled 157 holes targeted to a depth of 1,800 feet (549 meters). Once the freeze wall is created, groundwater will be pumped out of the test area and then integrity testing of the freeze wall strength will be conducted [94].

Figure 4-14. Shell In situ Conversion Process.

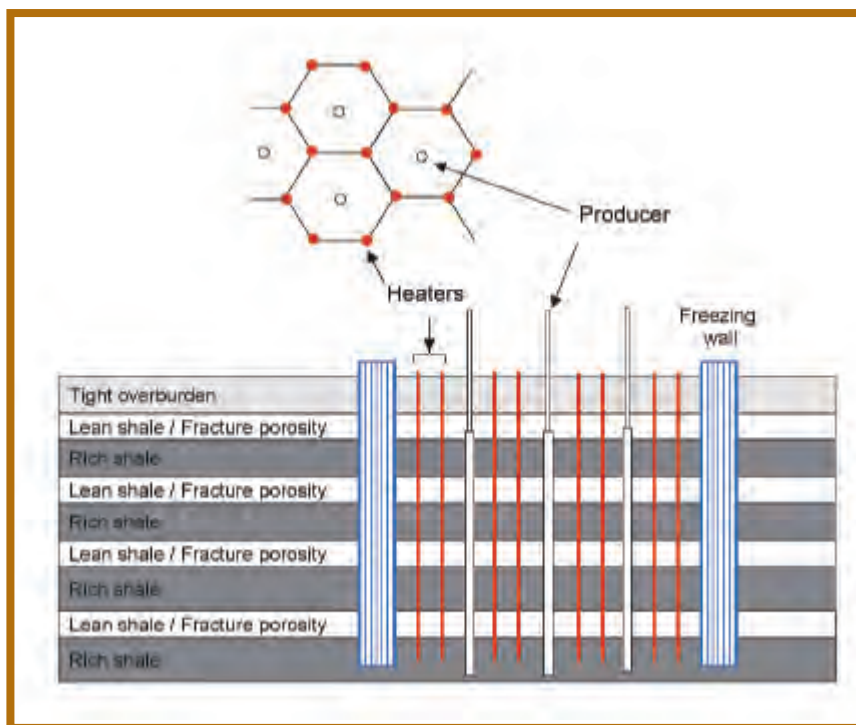

Source: A. Andrews, *Oil Shale: History, Incentives, and Policy*, 2006; Shell Oil Company, *Mahogany Research Project*, 2006

Shell's calculation of 3.5 units of energy gained from the oil shale for every unit of energy consumed through the electrical heating process assumes electricity is produced by an advanced, 60% efficient, combined cycle gas power plant. A standard new coal-fired plant has an efficiency rating of 35%, reducing the energy balance to two to one. Shell is working on gas-fired heating, which will utilize the natural gas being recovered from the drilling process, potentially improving the energy balance to 5.5 units of energy equivalent production to one unit heating [95].

The Shell ICP technology comes with its own set of concerns. For example, once the shale oil has been removed, how do the permeability and porosity of the rich and lean shale layers change? Other concerns include the possibility of groundwater contamination and the fate of the hydrocarbon gases released through this process. Many of these issues are currently being explored by Shell [94].

4.3.4 Ongoing Commercialization Efforts

Several emerging technologies for extracting oil from shale are currently being tested and refined in Utah and Colorado in an effort to determine their commercial viability. These efforts range from application of new surface mining and processing technologies to modified in situ methods. A few of these efforts are briefly outlined below.

4.3.4.1 Surface Mining and Extraction Processes

Oil Shale Exploration Company (OSEC) is applying the ATP technology to the processing of oil shale from the Green River Formation in Utah. OSEC was awarded a 160-acre (0.65 square kilometer) Research, Development, and Demonstration (RD&D) lease by the Bureau of Land Management (BLM) in December 2006 for the White River Mine site in Uintah County, Utah. OSEC plans to produce shale oil from the approximately 50,000 tons (45,000 metric tons) of previously mined oil shale available at the site [96].

4.3.4.2 In Situ Processes

Several companies are developing modified in situ processes. Three companies, Shell, Chevron, and EGL Resources, were awarded 160-acre (0.65 square kilometer) RD&D leases by the BLM for in situ projects in the Piceance Basin of Colorado. The Shell ICP process was described in Section 4.3.3.1. Chevron Corporation is developing an in situ process jointly with Los Alamos National Laboratory that combines fracturing, gas injection, and combustion. The first step in the process is to use conventional drilling technologies to drill wells. Then, a series of controlled horizontal fractures are applied within the target interval. It is critical that the fracturing be relatively uniform. Next, hot, CO₂-rich gases are circulated from well to well through the fractured formation and then back to a gas generator for reheating. In situ combustion of the remaining organic material in previously heated and depleted zones can also be used to heat the gases required for processing of successive intervals [97]. EGL Resources will use a proprietary technology that heats the shale indirectly (no fluid injection). The retorting energy will be delivered via a closed system that employs high temperature (1202°F/650°C) liquid heat transfer media [98].

Other technologies are also being pursued either in the laboratory or on oil shale deposits located on private land. ExxonMobil is researching a process whereby planar heat sources (fractures) are used to heat the resources instead of the line sources (well heaters) used in the Shell ICP process. Hydraulic fracturing is performed in the target interval and then the fractures are filled with an electrically conductive material, forming a heating element. Laboratory experiments and modeling have shown the efficacy of this method [99]. Mountain West Energy, a small Utah Company, has developed a novel gas injection technology in which heated methane is injected into a single well. The methane heats and pyrolyzes the target interval around the well. Gaseous products are then produced from the same well. Laboratory experiments of the process have yielded promising results [100].

A large amount of oil shale in the Green River Formation is accessible from the surface and is not suitable for in situ production. Some of the newly formed oil shale companies are combining the concepts of ex situ and in situ heating to capitalize on the

nature of the resource and the respective advantages of the two processes, including Red Leaf Resources in Salt Lake City, Utah.

The basic idea is to create an in situ environment in an ex situ process. The shale is mined from the richest and largest deposits and then crushed and piled into an embankment lined with clays or other impervious material. The embankment is capped with an appropriate impermeable layer. Horizontal wells are drilled into the structure and then heaters are inserted into the wells to provide a slow, steady heating source. The concept is to mimic in situ conditions in this embankment structure. As the source rock heats up, appropriately placed wells are used to collect the oil. Once oil production ceases, a heat scavenging program is used to scavenge/divert waste heat to adjacent embankments. Then, the structure is shut down. Reclamation is engineered to ensure no further environmental impact from the embankment [101]. The advantages of the technology are that features of in situ and ex situ methods are combined to process the oil shale. In fact, it may be possible to engineer improved “in situ” conditions in the embankment to produce better quality oil. However, mining would require its own infrastructure and remediation activities and the long-term environmental security of the embankment would have to be ensured.

4.4 References

- [1] Alberta Energy and Utilities Board Staff. *Alberta's Energy Reserves 2006 and Supply/Demand Outlook 2007-2015*; ST98-2007; Alberta Energy and Utilities Board: Calgary, Alberta, June 2007.
- [2] Oil Sands. <http://www.energy.gov.ab.ca/89.asp> (accessed June 18, 2007). Government of Alberta; Energy.
- [3] Hoekstra, G.B. Ignition Procedure and Process for In Situ Retorting of Oil Shale. U.S. Patent 4,425,967, January 17, 1984.
- [4] Britton, K. The Potential of In Situ Methods for Processing Eastern Oil Shale. In *Proceedings of the 1991 Eastern Oil Shale Symposium*, Lexington, KY, November 30-December 2, 1991; pp 315-324.
- [5] Johnson, H.R.; Crawford, P.M.; Bunger, J.W. *Strategic Significance of America's Oil Shale Resource: Volume I, Assessment of Strategic Issues*; AOC Petroleum Support Services, LLC: Washington, D.C., March 2004.
- [6] Johnson, H.R.; Crawford, P.M.; Bunger, J.W. *Strategic Significance of America's Oil Shale Resource: Volume II, Oil Shale Resources, Technology and Economics*; AOC Petroleum Support Services, LLC: Washington, D.C., March 2004.
- [7] Masliyah, J.; Zhou, Z.J.; Xu, Z.; Czarnecki, J.; Hamza, H. Understanding Water-Based Bitumen Extraction from Athabasca Oil Sands. *Canadian Journal of Chemical Engineering* **2004**, 82, pp 628-654.
- [8] Ophus, K. Removal of Hydrocarbons from Particulate Solids. International Patent Application number: PCT/CA2004/001826, April 20, 2004.
- [9] Snape, C. *Composition, Geochemistry and Conversion of Oil Shales*; NATO Science Series C: Mathematical and Physical Sciences, Vol. 455; Kluwer Academic Publishers: Boston, MA, 1995.
- [10] Dowd, W.T.; Kuuskraa, V.A.; Godec, M.L. *A Technical and Economic Assessment of Domestic Heavy Oil: Final Report*. DOE/BC/10840-1; Interstate Oil Compact Commission: Oklahoma, OK, January 1988.
- [11] Strycker, A.R.; Wadkins, R.; Olsen, D.K.; Sarkar, A.K.; Ramzel, E.B.; Johnson, W.I.; Pautz, J. *Feasibility Study of Heavy Oil Recovery in the United States*; NIPER/BDM-0225; BDM-Oklahoma, Inc.: Bartlesville, OK, March 1996.
- [12] Advanced Resources International. *Undeveloped Domestic Oil Resources: The Foundation for Increasing Oil Production and a Viable Domestic Oil Industry*; U.S. Department of Energy, 2006; p 16. Also available at <http://fossil.energy.gov/programs/oilgas/eor/>

- [Undeveloped Domestic Oil Resources Provi.html](#).
- [13] Monthly Production and Injection Databases. http://www.conservation.ca.gov/DOG/prod_injection_db/index.htm (accessed October 1, 2006). California Department of Conservation; Division of Oil, Gas & Geothermal Resources.
- [14] Alaska Department of Revenue, Tax Division. ANS & Cook Inlet Oil Production, FY 1978-2006. <http://www.tax.state.ak.us/programs/oil/production/historicaldata/FYPROD.pdf> (accessed June 18, 2007).
- [15] Pemex. *Pemex 2006 Annual Report*, Pemex Corporate Finance Office: C. P. 11311 México. Also available at <http://www.pemex.com/index.cfm?action=content§ionID=11&catid=149&contentID=2711>.
- [16] The Encyclopedia of Earth. Energy Profile of Mexico. http://www.eoearth.org/article/Energy_profile_of_Mexico#Crude_Varieties (accessed July 27, 2007).
- [17] Canadian Association of Petroleum Producers (CAPP). *Canadian Crude Oil Production and Supply Forecast, 2006-2020*, CAPP: Calgary, Alberta, May 2006. Also available at <http://www.capp.ca/raw.asp?x=1&dt=NTV&ce=PDF&dn=103586>.
- [18] Hanzlik, E.J.; Mims, D.S. *Forty Years of Steam Injection in California – The Evolution of Heat Management*. SPE International Improved Oil Recovery Conference in Asia Pacific, Kuala Lumpur, Malaysia, October 20-21, 2003; Society of Petroleum Engineers: Richardson, TX, 2003; SPE 84848.
- [19] Sarathi, P.; Olsen, D.K. *Practical Aspects of Steam Injections: A Handbook for Independent Operators*; NIPER-580; IIT Research Institute, National Institute for Petroleum and Energy Research: Bartlesville, OK, October 1992.
- [20] Ziegler, V.M.; Crookston, R.B.; Sanford, S.J.; Merrel, J.M. *Recommended Practices for Heat Management of Steamflood Projects*. SPE International Thermal Operations Symposium, Bakersfield, California, February 8-10, 1993; Society of Petroleum Engineers: Richardson, TX, 1993; SPE 25808.
- [21] Chu, C. State-of-the-Art Review of Steamflood Field Projects. *Journal of Petroleum Technology* **1985**, October, pp 1887-1902.
- [22] Taber J.J.; Martin, F.D.; Seright, R.S. EOR Screening Criteria Revisited – Part I: Introduction to Screening Criteria and Enhanced Recovery Field Projects. *SPE Reservoir Engineering* **1997**, 12(3), pp 189-198.
- [23] Taber J.J.; Martin, F.D.; Seright, R.S. EOR Screening Criteria Revisited – Part II: Applications and Impacts of Oil Prices. *SPE Reservoir Engineering* **1997**, 12(3), pp 199-206.
- [24] Vogel, J.V. Simplified Heat Calculations for Steamfloods. *Journal of Petroleum Technology* **1984**, July, pp 1127-1138.
- [25] Neuman, C.H. A Gravity Override Model of Steamdrive. *Journal of Petroleum Technology*, **1985**, January, pp 163-169.
- [26] Terez, I.E.; Barnhardt, C.M. *Effective Steamflood Management Using Heat and Mass Balance Model*. SPE Annual Technical Conference and Exhibition, October 3-6, 1999, Houston, TX; Society of Petroleum Engineers: Richardson, TX, 1999; SPE 56546.
- [27] Hayat, A.; Echols, D. *A New Reservoir Simulation Model for Understanding Reservoir Performance in the McKittrick Steam Drive*. SPE Western Regional Meeting, March 30-April 1, 2005, Irvine, CA; Society of Petroleum Engineers: Richardson, TX, 2005; SPE 93894.
- [28] Williams, L.L.; Fong, W.S.; Kumar, M. Effects of Discontinuous Shales on Multizone Steamflood Performance in the Kern River Field. *SPE Reservoir Evaluation & Engineering* **2001**, 4(5), pp 350-357.
- [29] Deo, M.D.; Forster, C.B.; Schamel, S. *Strategies for Steam Flood Optimization in a High-water Saturation Reservoir in the Midway Sunset Field*. International Thermal Operations/Heavy Oil Symposium, March 17-19, 1999, Bakersfield, CA; Society of Petroleum Engineers: Richardson, TX, 1999; SPE 54075.
- [30] French, M.R.; Siagian, M.; Thurston, F.K. *Overcoming the Challenges of Shallow Horizontal Drilling in the World's Largest Steamflood*. SPE Asia Pacific Oil and Gas

- Conference and Exhibition, April 20-22, 1999, Jakarta, Indonesia; Society of Petroleum Engineers: Richardson, TX, 1999; SPE 54289.
- [31] Schamel, S.; Deo, M.D. *Strategies for Optimal Enhanced Recovery of Heavy Oil by Thermal Methods, Midway Sunset Field, Southern San Joaquin Basin, California*. SPE Annual Technical Conference and Exhibition, October 1-4, 2000, Richardson, TX; Society of Petroleum Engineers: Richardson, TX, 2000.; SPE 63295.
- [32] Schamel, S.; Deo, M.D. *Role of Small Scale Variations of Water Saturations in Optimization of Steamflood Heavy Oil Recovery in the Midway Sunset Field, California*. SPE Western Regional/AAPG Pacific Section Joint Meeting, May 19-24, 2005, Long Beach, CA; Society of Petroleum Engineers: Richardson, TX, 2005; SPE 83499.
- [33] Hong, K.C.; Griston, S. Best Practice for the Distribution and Metering of Two-Phase Steam. *SPE Production & Facilities* **1997**, August, pp 173-180.
- [34] Johnson, D.O.; Sugianto, R.; Mock, P.H.; Jones, C.H. Identification of Steam-Breakthrough Intervals with DTS Technology. *SPE Production and Facilities* **2004**, 19(1), pp 41-48.
- [35] Galford J.E.; Marschall, D.M. *Combining NMR and Conventional Logs to Determine Fluid Volumes and Oil Viscosity in Heavy Oil Reservoirs*. SPE Annual Technical Conference and Exhibition, October 1-4, 2000, Richardson, TX; Society of Petroleum Engineers: Richardson, TX, 2000; SPE 63257.
- [36] Castrup, S.G. Recommended Practices for Slim-Hole Steam Injectors. *SPE Production & Facilities* **2001**, 16(3), pp 166-175.
- [37] Ramlal, V.; Singh, K.S. Success of Water-Alternating-Steam-Process for Heavy Oil Recovery. SPE International Thermal Operations and Heavy Oil Symposium, March 12-14, 2001, Porlamar, Venezuela; Society of Petroleum Engineers: Richardson, TX, 2001; SPE 69905.
- [38] Freedman, R.; Sezginer, A.; Flaum, M.; Matteson, A.; Lo, S.; Hirasaki, G.J. A New NMR Method of Fluid Characterization in Reservoir Rocks: Experimental Confirmation and Simulation Results. *SPE Journal* **2001**, 6(4), pp 452-464.
- [39] Stuebinger, L.A.; Elphinstone, G.M., Jr. Multipurpose Wells, Downhole Oil/Water Separation in the Future. *SPE Production & Facilities* **2000**, 15(3), pp 191-195.
- [40] Uphold, D.D.; Siboro, P.D.; Kouba, G.E. *Field Trial of Multiphase Metering Systems in Light Oil Steam Flood Applications, Minas – Indonesia*. SPE Asia Pacific Oil and Gas Conference and Exhibition, October 8-10, 2002, Melbourne, Australia; Society of Petroleum Engineers: Richardson, TX, 2002; SPE 77892.
- [41] Osterloh, T. W.; Jones, J. Novel Thermal Process for Recovery of Extremely Shallow Heavy Oil. *SPE Reservoir Evaluation & Engineering* **2003**, 6(2), pp 127-134.
- [42] Heim, R.N.; Hampton, T.J.; Laverty, B.A. *Quick Analysis of Steamflood, Bremer Fee, Midway Sunset Field, California, Using Production Enhancement Technologies (PET)*. SPE Western Regional/AAPG Pacific Section Joint Meeting, May 20-22, 2002, Anchorage, AK; Society of Petroleum Engineers: Richardson, TX, 2002; SPE 76731.
- [43] Uribe, Tom. New Oil Technology Answers Old Air Problems: Electric Downhole Steam Generation Process Will Improve Oil Production, Cut Air Pollution. www.FresnoStateNews.com, October 2005.
- [44] Schamel, S.; Deo, M. Role of Small-Scale Variations of Water Saturations in Optimization of Steamflood Heavy-Oil Recovery in the Midway-Sunset Field. *SPE Reservoir Evaluation & Engineering* **2005**, 9(2), pp 106-113.
- [45] Greaser G.R.; Shore, R.A. *Steamflood Performance in the Kern River Field*. SPE/DOE Enhanced Oil Recovery Symposium, April 20-23, 1980, Tulsa, OK; Society of Petroleum Engineers: Richardson, TX, 1980; SPE 8834.
- [46] Zahedi, A.; Johnson, R.; Rueda, C. *Heat Management in Coalinga - New Insight to Manage Heat in an Old Field*. SPE International Thermal Operations and Heavy Oil Symposium and Western Regional Meeting, March 16-18, 2004, Bakersfield, CA; Society of Petroleum Engineers: Richardson, TX, 2004. SPE 86984.
- [47] Ambastha, A.K.; Kumar, M. *New Insights into In-Situ Combustion Simulation for*

- Heavy Oil Reservoirs*. SPE Annual Technical Conference and Exhibition, October 3-6, 1999, Houston, TX; Society of Petroleum Engineers: Richardson, TX, 1999; SPE 56543.
- [48] Oblad, A.G.; Dahlstrom, D.A.; Deo, M.D.; Fletcher, J.V.; Hanson, F.V.; Miller, J.D.; Seader, J.D. *The Extraction of Bitumen from Western Oil Sands, Volume I*, DOE/MC/30256-99-Vol.1D; U.S. Department of Energy, Office of Fossil Energy: Washington, D.C., November 1997.
- [49] Oblad, A.G.; Bunger, J.W.; Hanson, F.V.; Miller, J.D.; Ritzma, H.R.; Seader, J.D. Tar Sand Research and Development at the University of Utah. *Annual Review of Energy* **1987**, *12*, pp 283-356.
- [50] Peramanu, S.; Pruden, B. B.; Rahimi, P. Molecular Weight and Specific Gravity Distribution for Athabasca and Cold Lake Bitumens and Their Saturates, Aromatics, Resin, and Asphaltene Fractions. *Industrial & Engineering Chemistry Research* **1999**, *38*, pp 3121-3130.
- [51] Hupka, J.; Oblad, A. G.; Miller, J. D. Diluent-Assisted Hot-Water Processing of Tar Sands. *AOSTRA Journal of Research* **1987**, *3*, pp 95-102.
- [52] Nevtah Capital Management Corporation. Oilsands Recovery Technology. <http://www.nevtahoilsands.com/> (accessed October 1, 2006).
- [53] Nasr, T.N.; Ayodele, O.R. *Thermal Techniques for the Recovery of Heavy Oil and Bitumen*. SPE International Improved Oil Recovery Conference in Asia Pacific, December 5-6, 2005, Kuala Lumpur, Malaysia; Society of Petroleum Engineers: Richardson, TX, 2005; SPE 97488.
- [54] Flint, L. *Bitumen Recovery Technology: A Review of Long Term R&D Opportunities*; LENE Consulting Limited, 2005.
- [55] Oil Sands Facts. <http://www.energy.gov.ab.ca/1876.asp> (accessed June 18, 2007). Government of Alberta; Energy.
- [56] Gray, M. Research Challenges for Sustainable Oil Sands Production. Research presentation to the Utah Heavy Oil Program, University of Utah, March 15, 2007.
- [57] Clark, K.A.; Pasternack, D.S. Hot Water Separation of Bitumen from Alberta Bituminous Sand. *Industrial Engineering Chemistry* **1932**, *24*, 1410-1416.
- [58] Bichard, J.A. *Oil Sands Composition and Behavior Research: The Research Papers of John A. Bichard, 1957-1965*; AOSTRA Technical Publication Series 4; Alberta Oil Sands Technology and Research Authority: Edmonton, Alberta, 1987.
- [59] Romanova, U.G.; Yarranton, H.W.; Schramm, L.L.; Shelfantook, W.E. Investigation of Oil Sands Froth Treatment. *Canadian Journal of Chemical Engineering* **2004**, *82*, pp 710-722.
- [60] Shelfantook, W.E. A Prospective on the Selection of Froth Treatment Processes. *Canadian Journal of Chemical Engineering* **2004**, *82*, pp 704-709.
- [61] McLendon, T.R.; Bartke, T.C. *Tar Sand, Technology Status Report*; DOE/METC-91/0274 (DE91002070); Office of Fossil Energy, U.S. Department of Energy: Morgantown, WV, 1990.
- [62] Sepulveda, J.E. ; Miller, J.D.; Oblad, A.G. Hot Water Extraction of Bitumen from Utah Tar Sands. *American Chemical Society, Division of Fuel Chemistry, Preprints* **1976**, *21(6)*, pp 110-122. From: American Chemical Society Meeting, San Francisco, CA, August 29-September 3, 1976.
- [63] Gray, M. Personal communication, April 2007.
- [64] Temple Mountain Energy, Inc. U.S. Oil Sands Production Project. <http://www.templemountainenergy.com/> (accessed September 7, 2007).
- [65] Earth Energy Resources Inc. <http://www.earthenergyresources.com/index.php> (accessed September 7, 2007).
- [66] Bunger, J.W.; Mori, S.; Oblad, A.G. Processing of Tar Sand Bitumens. Part I, Thermal Cracking of Utah and Athabasca Tar Sand Bitumens. *American Chemical Society – Division of Fuel Chemistry, Preprints* **1976**, *21(6)*, pp 147-158. From: Symposium on Oil Shale, Tar Sands, and Related Materials – Production and Utilization of Synfuels, American Chemical Society Meeting, San Francisco, CA, August 29-September 3, 1976.

- [67] Cha, S.M. Pyrolysis of Oil Sands from the Whiterocks Tar Sand Deposit in a Rotary Kiln. Ph.D. Dissertation, University of Utah, Salt Lake City, UT, 1991.
- [68] Sandler, K. and Davis, P. In Situ Bitumen Overview and Activity Update in the Province of Alberta. SPE/PS-CIM/CHOA International Thermal Operations and Heavy Oil Symposium, November 1-3, 2005, Calgary, Alberta; Society of Petroleum Engineers: Richardson, TX, 2005; SPE 97800
- [69] Devon Canada Corporation. Dover SAGD progress Review- Thermal heavy oil. <http://www.eub.ca/docs/products/osprogressreports/2005/2005AthabascaDevonDoverSAGD9045.pdf> (accessed July 20, 2007). Presentation dated April 28, 2005.
- [70] Meldau, R.F.; Shipley, R.G.; Coats, K.H. Cyclic Gas/Steam Stimulation of Heavy Oils. *Journal of Petroleum Technology* **1981**, 33(10) 1990-1998.
- [71] Lui, E.L. *Imperial Oil – A Leader in Thermal In-situ Production*. Edmonton CFA Society Conference: Investing in Alberta's Oil Sands, Edmonton, Alberta, June 8, 2006. Also available at http://www.imperialoil.ca/Canada-English/News/Speeches/N_S_Speech060608.asp.
- [72] Léauté, R.P.; Carey, B.S. *Liquid Addition to Steam for Enhancing Recovery (LASER) of Bitumen with CSS: Results from the First Pilot Cycle*. Sixth Annual Canadian International Petroleum Conference (56th Annual Technical Meeting), Calgary, Alberta, June 7-9, 2005; CIPC Paper Number 2005-161.
- [73] Petro-Canada. *In situ* Research and Development. <http://www.petro-canada.ca/en/about/636.aspx> (accessed October 1, 2006).
- [74] Mastmann, M.; Fabel, G. Reviewing the Strategy of Steamfloods in a Dipping Reservoir. SPE/DOE Improved Oil Recovery Symposium, April 19-22, 1998, Tulsa, OK; Society of Petroleum Engineers: Richardson, TX, 1998; SPE 39608.
- [75] Burger, J.; Sourieau, P.; and Combarous, M. *Thermal Methods of Oil Recovery*, Editions TECHNIP: Paris, 1985.
- [76] Xia, T.X.; Greaves, M. Upgrading Athabasca Tar Sand Using Toe-to-Heel Air Injection. SPE/CIM International Conference on Horizontal Well Technology, November 6-8, 2000; Calgary, Alberta; Society of Petroleum Engineers: Richardson, TX, 2000; SPE 65524.
- [77] Petrobank Energy and Resources Ltd. THAI Technology. <http://www.petrobank.com/hea-thaitechnology.html> (accessed May 10, 2007).
- [78] Bartis, J. T.; LaTourrette, T.; Dixon, L.; Peterson, D. J.; Cecchine, G. Oil Shale Development in the United States; MG-414-NETL; RAND Corporation: Santa Monica, CA, 2005.
- [79] Dyni, J. R. Geology and Resources of Some World Oil-Shale Deposits. *Oil Shale* **2003**, 20(3), pp 193-252. Also available at http://www.krijj.ee/oilshale/vol_20_3.html.
- [80] Bates, R.L.; Jackson, J.A. *Dictionary of Geological Terms*, American Geological Institute, Anchor Press: Garden City, NY, 1983.
- [81] Mölder, L., Estonian Oil Shale Retorting Industry At The Crossroads. *Oil Shale* **2004**, 21(2), 97-98.
- [82] Bird, K.J. North American Fossil Fuels. In *The Geology of North America—An Overview*; Bally, A.W., Palmer, A.R., Eds.; The Geology of North America, Vol. A; Geological Society of America: Boulder, CO, 1989; pp 555-573.
- [83] Yen, T.F.; Chilingar, G.V. Introduction to Oil Shales. In *Oil Shale*; Yen, T.F., Chilingar, G.V., Eds.; Elsevier Science Publishing Company: Amsterdam, 1976; pp 1-12.
- [84] U.S. Office of Technology Assessment. *An Assessment of Oil Shale Technologies, Volume I*; PB80-210115; Congress of the United States: Washington, D.C., 1980.
- [85] Dinneen, G.U. Retorting Technology of Oil Shale. In *Oil Shale*; Yen, T.F., Chilingar, G.V., Eds.; Elsevier Science Publishing Company: Amsterdam, 1976, pp 181-198.
- [86] Koszarycz, R.; Padamsey, R.; Turner, L.R.; Ritchey, R.M. The AO STRA Taciuk Processing- Heading into the Commercialization Phase. In *Proceedings of the 1991 Eastern Oil Shale Symposium*, Lexington, KY, November 30-December 2, 1991; pp 106-115.
- [87] Koel, M. Estonian Oil Shale. www.kirj.ee/oilshale/Est-OS.htm (accessed June 18,

- 2007). Oil Shale, A Scientific-Technical Journal, Oil Shale Extra.
- [88] Schmidt, S.J. New Directions for Shale Oil: Path to a Secure New Oil Supply Well into This Century [On the Example of Australia]. *Oil Shale* **2003** 20(3), pp 333-346.
- [89] UMA. UMATAC and the Alberta Taciuk Process. <http://www.uma.aecom.com/MarketsAndServices/41/64/index.jsp> (accessed October 1, 2006).
- [90] Laherrere, J. Review on Oil Shale Data, <http://www.hubbertpeak.com/laherrere/OilShaleReview200509.pdf> (accessed May 10, 2007). September 2005.
- [91] Andrews, A. *Oil Shale: History, Incentives, and Policy*; RL33359; CRS Report for Congress, Congressional Research Service: Washington, D.C., April 13, 2006.
- [92] Berkovich, A.J.; Young, B.R.; Levy, J.H.; Schmidt, S.J. Predictive Heat Model for Australian Oil Shale Drying and Retorting. *Energy and Fuels* **2000**, 39(7), pp 2592-2600.
- [93] Mut, S. *Shell Unconventional Resources Energy*. Testimony at the Oil Shale and Oil Sands Resources Hearing, Senate Energy and Natural Resources Committee, April 12, 2005. Available at http://energy.senate.gov/public/index.cfm?FuseAction=Hearings.Testimony&Hearing_ID=1445&Witness_ID=4139.
- [94] Shell Oil Company. Welcome to the Mahogany Research Project. http://www.shell.com/home/Framework?siteId=us-en&FC2=/us-en/html/iwgen/leftnavs/zzz_lhn4_4_0.html&FC3=/us-en/html/iwgen/shell_for_businesses/exploration_production_shared/mahogany_shared/dir_mahogany.html (accessed August 11, 2007).
- [95] Vinegar, H.J. Shell Oil Company. Personal communication, July 2006.
- [96] Oil Shale Exploration Company, LLC. www.oilshaleexplorationcompany.com (accessed September 4, 2007).
- [97] Green Car Congress. Chevron and Los Alamos Jointly Research Oil Shale Hydrocarbon Recovery. http://www.greencarcongress.com/2006/09/chevron_and_los.html (accessed September 11, 2007).
- [98] EGL Resources, Inc. – Oil Shale Division. Innovation in Oil Shale Technology, Research Testing. www.egloilshale.com (accessed September 11, 2007).
- [99] Symington, W.; Olgaard, D.L.; Otten, G.A.; Phillips, T.C.; Thomas, M.M.; Yeakel, J.D. *ExxonMobil's Electrofrac Process for In-situ Oil Shale Conversion*. Proceedings of the 26th Oil Shale Symposium, October 16-20, 2006, Golden, CO; Paper S05B.
- [100] Mountain West Energy. <http://www.mtnwestenergy.com/oilshale.html> (accessed September 11, 2007).
- [101] Patten, J.W. *Redleaf Resources*. Presentation at the Utah Energy Summit, April 15, 2007. Also available at http://www.utahenergysummit.com/Presentations/April_17_2007/James.Patten.Final%5B1%5DApril%20Energy,%

5

Upgrading and Refining

5 Upgrading and Refining

While light crude oils are readily refined into useful products like gasoline, diesel, and kerosene, lower API crude oils (heavy oil, oil sand bitumen, and shale oil) produce lower quantities of conventional refinery products. As a result, the value of these oils is less than that of higher API crude oils. For example, in 2006, California 13° API heavy crude oil traded at an \$11.87 per barrel discount to West Texas Intermediate (WTI) crude [1]. For Canadian-produced bitumen, the market is difficult to track as there are no posted prices. However, the Canadian Association of Petroleum Producers states that from 1997-2004, the price of bitumen averaged 51% of that of WTI crude [2].

A discussion on WTI crude and discount pricing is found in Section 6.1.

The process of converting these lower value oils to higher API oils more suitable for conventional refinery feedstocks is called upgrading. Partial upgrading renders the heavy oil/bitumen suitable for transportation to a refinery by reducing its viscosity and density [3]. The most common international standard for upgrading is the conversion of the vacuum residue, a fraction that most refiners do not value, to lower boiling point fractions.

Vacuum residue is the cut which boils above 1000°F/538°C.

In the Rocky Mountain region of the United States, where oil sands and oil shale development is most likely to occur, very limited refinery capacity exists for processing heavy oils such as bitumen (see Sections 5.2.1 and 6.5). In addition, no partial upgrading capacity exists in either Colorado's Piceance Basin or Utah's Uinta Basin, the probable epicenter for both oil sands and oil shale development. These basins are currently served by two ten-inch pipelines operated by Chevron Pipeline Company (see Section 6.2.2), but the pipelines could not be utilized unless partial upgrading were available in the field. Then, additional pipeline capacity would be needed to handle the volume of expected product. This situation is already being faced in Canada, with potential production expected to be constrained by existing pipeline capacity within a decade [4]. Because the Rocky Mountain region has the highest refinery capacity utilization in the country, partially or fully upgraded synthetic crude oil produced from oil sands and oil shale would need to be shipped to other regions of the country for refining (see Section 6.2.1).

The Shell ICP process produces a refinery-ready shale oil that will not require partial upgrading prior to transportation to a refinery; see Section 4.3.3.

This section begins with a review of the market for partially or fully upgraded synthetic crude oil. Given the current and potential demand for upgrading in the Rocky Mountain region and in the United States as a whole, Canadian upgrading and refining strategies are then briefly reviewed, followed by a review of potential technologies for upgrading of U.S. unconventional fuels.

5.1 Unconventional Fuels Market

The 1996 report entitled Feasibility Study of Heavy Oil Recovery in the United States estimated that an incentive of \$2.90/barrel would be required to achieve a production increase of 300,000 barrels of heavy oil per day by 2010 [5]. Since then, the market has seen this level of increase and more from Canadian oil/bitumen production. Although this increase occurred without the use of incentives, the market has been aided by favorable royalty terms. Prior to 1997, royalties were negotiated with Canadian oil sands project developers on a case-by-case basis. Contracts reflected the infant nature of the industry and the changing knowledge base as development accelerated. In 1997, Alberta enacted the Oil Sands Royalty Regulation, which stipulates

a royalty of 1% of gross revenue until project payout, followed by 25% of net revenue after payout [6]. These royalty contracts have been crucial in the rapid development of the Canadian oil/bitumen market. Canadian oil sands production is approximately one million BOPD and increasing. Based on anticipated growth, production could increase to 3 million BOPD by 2020 [7]. In comparison, California heavy oil production averaged 450,000 BOPD in 2005 (see Figure 4-1).

The level of Canadian oil sands production is beginning to impact refining dynamics in the United States. The Interstate Oil and Gas Compact Commission (IOGCC) provides a detailed analysis of crude oil market dynamics throughout the United States. In an analysis of the Rocky Mountain region (Montana, North Dakota, Wyoming, South Dakota, Colorado, and Utah), local production has increased from a low of 357,000 BOPD in December 2002 to 464,000 BOPD in June 2006. In that same time period, Canadian imports into the region averaged 315,000 BOPD [8]. An example of how the refining dynamic is affected by this volume of Canadian imports is found in Salt Lake City, Utah. About one-third of the Salt Lake refinery capacity of 150,000 BOPD is imported from Canada [8]. Due to the high quality and large volume of the Canadian oil imports, there is a significant differential between the price of the benchmark WTI crude and the price of the locally-produced, waxy crude oils. This differential has hovered around \$10/barrel but has reached \$20/barrel during 2006 [8].

5.2 Canadian Upgrading and Refining Strategies

In 2004, the province of Alberta established the Hydrocarbon Upgrading Task Force (HUTF). The purpose of the task force was to produce an action plan for achieving maximum upgrading of Alberta's bitumen resources, given that the resource size signifies its potential to be a long-term supply of competitively priced refining and petrochemical feedstocks [9]. The four priority objectives of HUTF were to develop a business case to support an industrial complex for the upgrading of bitumen into transportation fuels and petrochemicals in Alberta, to develop an environment that supports technology and process development that will secure a favorable competitive position, to review best practices and benchmarks from jurisdictions that have successfully developed energy industrial complexes, and to identify the labor, infrastructure and logistical challenges to development in Alberta [9].

In addition to HUTF, Alberta has several organizations dedicated to heavy oil and bitumen upgrading research, including the National Centre for Upgrading Technology (NCUT) and the Alberta Research Council (ARC). NCUT was formed in 1995 as a partnership between the Canadian federal and Alberta provincial governments with a mission to produce fuel products from bitumen-derived crude oils. Its technology research focuses on improving energy efficiency and reducing greenhouse gas emissions in the heavy oil upgrading and refining industries [10]. ARC is a not-for-profit applied research and development corporation that is wholly owned by the province of Alberta. ARC conducts upgrading and refining research as a joint venture partner with NCUT. Areas of research include improvements to existing upgrading technologies, increased energy efficiency and environmental performance, development of next-generation upgrading technologies, emissions reduction in bitumen and heavy oil processing plants, catalyst testing for various upgrading technologies, and studying the fundamentals of coking and fouling in refinery units [11].

A catalyst is a substance that affects the rate of chemical reaction without being changed or consumed in the overall reaction.

Coking is the formation of a carbonaceous material upon heating of hydrocarbons in the presence or absence of a catalyst. Deposition of this coke on catalysts and other solid surfaces is called fouling.

Research is driven by the need to reduce both the economic and environmental costs of upgrading bitumen. Significant investment is required to make a refining operation “bitumen friendly.” If upgrading and refining facilities were integrated in the same plant, the facilities required to fully upgrade bitumen to synthetic crude oil, a “typical” refinery feedstock, would constitute 90% of the plant [12]. Bitumen producers and conventional refineries must answer the difficult question of where to add value: upgrading investment or refinery investment?

One significant cost of upgrading is the extensive use of natural gas as a source of hydrogen to increase hydrogen to carbon (H/C) ratios in the products, a process known as hydrotreating. An upgrading option for reducing natural gas use, currently being implemented in some Canadian refineries, combines solvent deasphalting with gasification as shown in Figure 5-1. The gasification unit in Figure 5-1 produces some or all of the hydrogen required for the process. As a result, use of natural gas for the production of hydrogen is reduced.

Figure 5-1. Combination of technologies to reduce dependence of upgrading on natural gas.

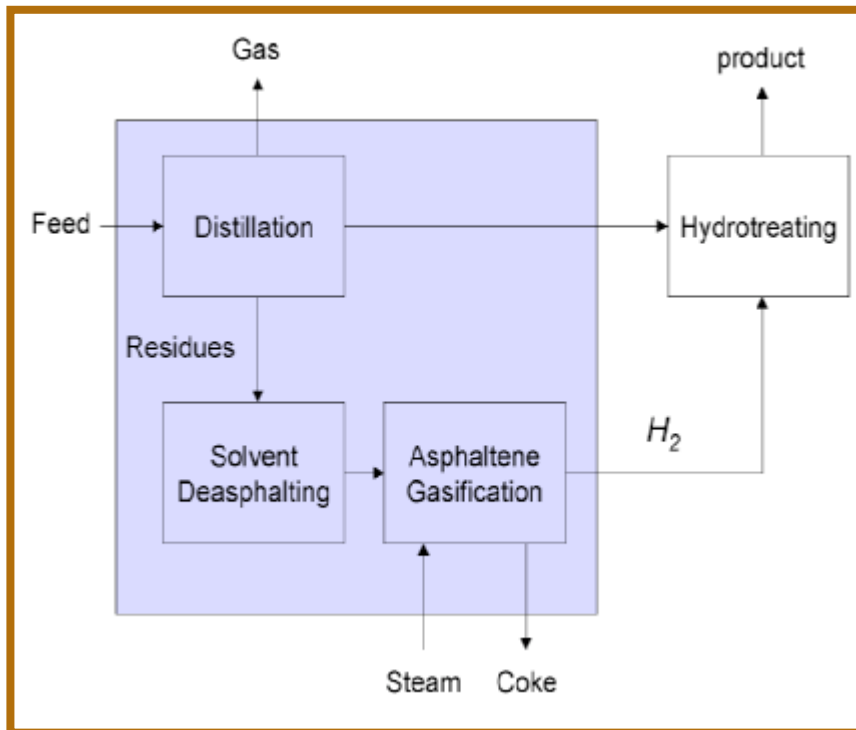

Source: Utah Heavy Oil Program

Another environmental cost of upgrading is the generation of carbon dioxide (CO₂) for energy production. Current upgrading technologies produce 37 kilograms of CO₂ per barrel of oil [13]. A third cost is the management of byproducts that have limited markets. Currently, significant amounts of waste coke are being generated in Alberta, and this coke has no value [14]. In an application for an oil sands mine and bitumen extraction and upgrading plant in the Fort McMurray area of Alberta, a proposed 233,000 barrels (37,000 cubic meters) per day of upgraded bitumen product would produce 3 million tons per year of waste coke.

In solvent deasphalting, heavy oil is mixed with a light solvent and separated into fractions based on molecular weight. One product is a refinery-ready, low-contaminant, deasphalted oil. The other product, insoluble pitch that precipitates out of the solution, requires further upgrading prior to refining.

Gasification is a process in which a carbonaceous material (e.g. natural gas, liquid hydrocarbon, coal, or heavy oil residue) is reacted with steam to produce a mixture of carbon monoxide and hydrogen known as synthesis gas or syngas. This process is also called steam reforming.

Currently, three products are marketed from oil/bitumen produced in Canada: a fully upgraded (~30°API) Synthetic Crude Oil (SCO); a bitumen product, DilBit, which is diluted with any light hydrocarbon mixture; and a mixture of SCO and bitumen called SynBit. Depending on their composition, SynBit and DilBit require significant upgrading, ranging from molecular weight reduction to heteroatom removal.

Molecular weight reduction increases the API gravity of the bitumen.

In crude oils, a heteroatom is any atom that is not hydrogen or carbon and is typically either nitrogen, sulfur, oxygen or a heavy metal atom.

5.3 Upgrading of U.S. Unconventional Fuels

The choices for upgrading heavy oil in the western United States will depend on the quality of the oil produced, the refining market and pipelines available at the time, the energy sources (gas, coal, etc.) in the vicinity, the qualities of other crude oils being produced at the time, and a number of other factors. Since shale oil is produced by thermal means, it is partially upgraded and may only require mild hydrotreatment for the removal of nitrogen, heavy metals (vanadium, arsenic, etc.), and possibly sulfur depending on the shale. Bitumen produced from oil sands, via surface extraction methods or in situ processes, will require more extensive upgrading.

The slate of upgrading processes currently available are tabulated in Table 5-1 [15-17]. Also included are basic technology definitions. The success of the unconventional fuel industry in the United States will depend on how effectively these technologies are integrated into the current refinery framework. These technologies will also play a pivotal role in making bitumen and shale oil suitable as refinery feedstocks.

In Table 5-1, the technologies are classified as primary, secondary or enhanced. Primary upgrading is mainly a molecular weight reduction process, while secondary upgrading involves removal of impurities from the feed. The primary upgrading processes may or may not use a catalyst, while the secondary processes are catalytic. Emerging technologies have been classified as enhanced upgrading methods. The mainstay of the oil sands upgrading operations in Canada has been coking, either delayed coking or flexicoking. Hydrotreating is less common but has been used in upgrading conventional heavy oil (of the type produced in California).

Operating conditions for some of the processes are summarized in Table 5-2 [17-19].

Table 5-1. Available upgrading processes.

Upgrading	Technology		Catalyst	General description	Product/Conversion of Vacuum Residue	Pros/cons
Primary	Thermal cracking	Visbreaking	Non-catalyst	Residue stream is heated in a furnace and then cracked in a reactor; Process employs soaking and quenching zones to avoid coking.	Liquid products are typical distillates that contain sulfur, nitrogen and metals, requiring secondary upgrading	Increase refinery net distillates yield, lower investment than catalytic hydrocracking
		Delayed coking		Heavy oil/bitumen is thermally decomposed in an oxygen-free environment.	Bitumen cracks into gas vapor and solid coke. Coke is used as a fuel for producing the heat	Flexibility to handle any type of residue, but high coke formation and low yield of liquid product
		Fluid coking and flexicoking		Developed from FCC; circulating coke carries heat from burner to reactor	Cracking produces gases, distillates, and coke	Better heat integration and improved liquid products compared to delayed coking
	Fluid catalytic cracking (FCC)		Catalyst	Enhanced form of thermal conversion using catalyst	Converts the heavy fractions into high molecular weight gasoline components	More expensive, but more upgraded product than thermal conversion
	Hydroconversion/hydropropylolysis			High pressure hydrogen is added in the process of catalytic cracking	Presence of hydrogen promotes lighter and hydrogen rich molecules reducing alkenes	More expensive, but more upgraded products for the refinery than coking and visbreaking
Secondary	Hydrocracking		Catalyst	Used on gas oils or deasphalted feeds. High pressure catalytic process; active catalyst gives both cracking and hydrogenation to unsaturated molecules	Process converts feed into input stream for gasoline production	Higher hydrogen pressure required than in hydroconversion and hydrotreating
	Hydrotreating			Used on gas oils, kerosene and naphtha produced from bitumen to remove heteroatoms. Cracking activity is minimal.	Removal of sulfur (>90%), nitrogen (>70%) and metals such as vanadium and nickel	Lower temperature processing than hydrocracking
Enhanced upgrading	Solvent deasphalting and supercritical extraction		Non-catalyst	Asphaltenes are precipitated from residue by addition of a paraffinic solvent such as propane, butane, pentane or hexane	Deasphalted oil is normally used as FCC and/or hydrocracking feedstock	Costs of solvent recovery are high
	Gasification			Asphaltenes or heavy residues are reacted with steam at high temperatures (>1000°C).	High temperature reaction produces syngas (a mixture of carbon monoxide and hydrogen), carbon black and ash	An integrated gasification-upgrading plant has the potential of being self sufficient in energy and hydrogen requirements
	Novel hydrovisbreaking and fast pyrolysis			Major objective is viscosity reduction	Ongoing research	Low operational costs

Typical distillates include gasoline, kerosene, and diesel.

In thermal cracking, heavier molecules in a crude oil are converted to lighter products by noncatalytic heating of the feed.

During the coking process, heavy oil/bitumen is thermally decomposed in an oxygen-free environment to form the solid carbonaceous product, coke.

Hydroconversion can be classified as either a non-catalytic or a catalytic process depending on the existence of catalyst. The reaction is always carried out in the presence of hydrogen.

Hydrocracking is a combination of molecular weight reduction and hydrotreatment.

Source: M.S. Rana et al., *A Review of Recent Advances on Process Technologies for Upgrading of Heavy Oils and Residuals*, 2007; M. Gray, *Tutorial on Upgrading of Oil Sands Bitumen*; J. H. Gary et al., *Petroleum Refining: Technology and Economics*, 2007

Table 5-2. Operating temperatures and pressures of upgrading technologies.

Process	Temperature	Pressure	Additional content
Visbreaking	427-510°C (800-950°F)	Atmospheric	-
Delayed coking	482-510°C (900-950°F)	15-90 psia	Higher temperatures (510-538°C, 950-1000°F) are used in Flexicoking
FCC	482-538°C (900-1000°F)	10-30 psia	-
Hydrocracking	399-816°C (750-1500°F)	1000-2000 psia	Hydroconversion operates at lower temperature and pressure than hydrocracking
Hydrotreating	316-427°C (600-800°F)	Up to 1000 psia	-

Source: J.H. Gary et al., *Petroleum Refining: Technology and Economics*, 2007; J.G. Speight and B. Özüm, *Petroleum Refining Processes*, 2002; *The Encyclopedia of Earth*

Pressure is defined as force per unit area. It can be measured as pounds per square inch absolute (psia), which is the pressure above absolute zero pressure (a perfect vacuum).

5.3.1 Oil Sands Bitumen

In the western United States, the bitumen derived from oil sands will need to be transported to refineries for upgrading to valuable liquid fuels such as gasoline and diesel. The bitumen can be transported by diluting it with crude oil or with lighter solvents or by emulsifying the bitumen in water.

If the bitumen is treated in a central facility as in Canada, a number of process combinations from Table 5-1 could be effective depending on the location, market, and energy sources available. Some of these combinations are:

- Hydroconversion
- Partial upgrading by coking followed by hydrotreating, which is the current practice in Canada
- Gasification of the coke produced to supply the needed hydrogen
- Solvent deasphalting of the heavy oil, followed by hydrotreatment/hydrocracking of the heaviest portion of the oil
- Fluid catalytic cracking (FCC) to produce medium API crude oil
- Short residence time thermal cracking to produce medium API crude oil, a process currently implemented commercially in Texas.

An overall comparison of some of these upgrading technologies on conversion results from a Utah bitumen is shown in Table 5-3 [20]. Coking, the most common upgrading method, produces a liquid that is similar in properties to conventional crude oil, i.e. high API gravity and low residue content. However, the total conversion is only about 60-70% with the rest of the oil forming coke. Higher conversions are obtained with the catalytic cracking and hydrolysis options, but the catalyst and/or hydrogen requirements add to the process cost.

Table 5-3. Comparison of yield and conversion results for upgrading of Asphalt Ridge bitumen.

Process	Yield (wt%)		API of liquids	% distillable from liquids	Conversion
	Gases	Liquids			
Visbreaking	1	99	-	67	46
Coking (80 psia)	7	70	34	100	62
Coking (0 psia)	4	83	27	97	74
Catalytic cracking	10	79	30	98	80
Hydropyrolysis	27	73	25	85	82

Source: A.G. Oblad et al., *Tar Sand Research and Development at the University of Utah, 1987*

The column labeled “% liquids distillable” refers to the percent of liquid products that boil below 1000°F (538°C).

Conversion is defined as the percentage of > 1000°F (538°C), boiling material converted to < 1000°F (538°C) boiling material. The percentage of > 1000°F (538°C) boiling material in the virgin bitumen was 60%.

5.3.2 Shale Oil

The need for shale oil upgrading is illustrated in Table 5-4 [21]. Raw shale oil produced from either an in situ or ex situ retorting process would have properties in the range shown in column one, including significant quantities of nitrogen, which requires removal by hydrotreating. The high pour point of shale oil may also be an issue in transporting the oil to a refinery for further processing. The approximate properties of an upgraded shale oil are given in column two. For comparison, the properties of a light Arab crude are also shown in the Table 5-4. The raw shale oil is a thermally processed material. As a result, it has good distillate distribution and, on average, a low concentration of residue (1000°F+ material). Upgrading improves the API gravity of the shale oil and lowers its pour point to acceptable limits; nitrogen and sulfur concentrations are reduced as well.

Table 5-4. Properties of shale oil (raw and upgraded) and of a light Arab crude.

	Raw shale oil	Upgraded shale oil	Arabian light crude
API	20 - 26	38	34
Sulfur, wt%	0.7	0.01	1.7
Nitrogen, wt%	1.9	0.1	0.07
Pour point, °F	70 - 90	0	-10
Solids, wt%	1 - 2	-	-
Distillate, vol%			
104° – 800°F	54	73	67
800°F +	45	26	32
1000°F +	7	2	17

Source: S.F. Culberson, *The Outlook for Oil Shale, 1982*

Pour point is the temperature below which a liquid stops flowing. A standard test is used to measure this temperature.

Public disclosures by Shell state that the shale oil produced by their ICP process is a refinery-ready feedstock that requires no upgrading [22], thereby reducing post-production costs. The oil can be pumped directly into refinery pipelines and sent to refineries with hydrotreaters. This shale oil may even command a premium price given its very low sulfur content and high gasoline yield.

5.4 Primary Upgrading Technologies

Comparing the effectiveness and suitability of various upgrading technologies can be challenging since the same technologies are not used on all feedstocks [23]. One basis for comparison is the most common international standard, the conversion of the vacuum residue to lower boiling fractions. However, in many cases (i.e. such as most shale oils), the vacuum residue fraction of the feedstock is unknown. Liquid yield is another of the many criteria that determine the suitability of an upgrading process. In the brief summary and comparison of upgrading technologies from Table 5-1 provided below, information relating to the conversion of the vacuum residue and to liquid yields is provided when available.

5.4.1 Visbreaking

Visbreaking is a mild (atmospheric) thermal cracking process in which heavy hydrocarbons are transformed into lighter hydrocarbons in the presence of air, reducing the pour point and the viscosity of the feedstock. When treating bitumen or residues, the feedstocks are heated to operating temperatures in the range of 800°-950°F (427°-510°C) and held there for a period of time ranging from several seconds to several minutes. The liquid product is cooled, and the gases evolved during the heating phase are removed. Visbreaking increases the refinery net distillates yield and requires less investment than catalytic cracking. However, as little change is observed in the nitrogen, sulfur and oxygen content of the oil, secondary upgrading is required.

The distillates or liquid yield is the quantity of medium to light hydrocarbons that are produced from the heavy hydrocarbon feedstock. Middle distillates include diesel and heating oil while light distillates include gasoline and liquefied petroleum gas (LPG).

Researchers have used visbreaking to upgrade Utah oil sand bitumen with liquid yields of 99% as shown in Table 5-3 [20,24], but further processing of the liquids would be required to produce a synthetic light crude oil. In addition, visbreaking does not achieve significant conversion of the vacuum residue portion of the Utah oil sand bitumen.

5.4.2 Delayed coking

Two of the largest oil sands processing companies in Canada, Syncrude and Suncor, employ coking in their upgrading process. Suncor uses the traditional delayed coker, while Syncrude utilizes the fluid coking scheme (see Section 5.4.3).

Coking or delayed coking, which is a thermal upgrading technique, can significantly improve the quality of oil sands bitumen. Coking involves heating the oil to the 900°-950°F temperature range (482°-510°C) and then charging it into a vessel in which thermal decomposition to gases occurs in an oxygen-free environment. The gases are then condensed to obtain liquid yields in the 70-80% range on a volume basis (mass yields are lower), with the remainder of the oil forming the solid product, coke. Although coking is commonly called a carbon rejection technology, the coke contains almost the same carbon content as the feedstock. Because the liquid product does not contain any vacuum residue, coking is an excellent upgrading process by itself. Delayed coking is a flexible process and can be applied to any feedstock.

5.4.3 Fluid Coking and Flexicoking

In the fluid coking process, hot oil is charged into a vessel that contains a fluidized bed of coke particles. The particles become coated with oil, which then decomposes to yield gases and another layer of coke. The gases are then withdrawn from the vessel and condensed to obtain the liquid yield. Circulating coke carries heat from the burner to the reactor.

In a fluidized bed, a bed of small particles is suspended and kept in motion by the upward flow of a fluid.

A schematic of a fluid coker is shown in Figure 5-2 [25]. The four components of the fluid coker (boiler, burner, fluid coker, and scrubber) allow for good heat integration and control over product quality. The scrubber allows initial product fractionation before the products are sent to the finishing unit. The capital costs for fluid coking are comparable to those of delayed coking, but the overall cost per barrel is higher because energy is consumed during coke circulation in the fluid coker [17].

Figure 5-2. Schematic of a fluid coker.

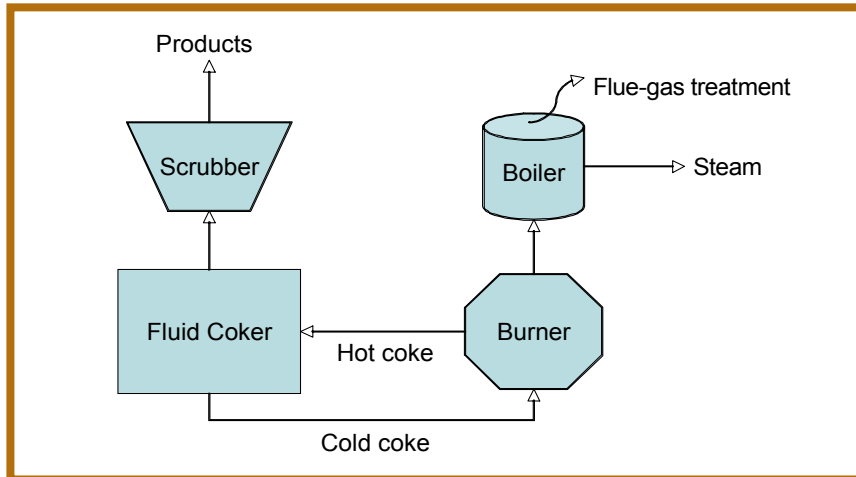

Source: D. G. Hammond et al., *Review of FLUID COKING™ and FLEXICOKING™ Technologies*, 2003

Another coking process that adds a gasification step to reduce natural gas consumption is called Flexicoking. In Flexicoking, part of the coke is gasified to synthesis gas (syngas). The syngas can be used as a low-quality fuel or cleaned up for hydrogen recovery. Hydrogen can subsequently be used in the hydrogen addition step for nitrogen or heavy metal removal. Some studies have shown that the capital cost for Flexicoking units are comparable to capital expenditures for delayed coking, while other studies report capital costs for Flexicoking that are 30-50% higher and operating costs that are 25-30% higher [17,18] than for comparable delayed coking facilities. These claims have not been verified for the upgrading of oil sands bitumen.

There are Flexicoking units around the world for upgrading heavy oil residues, but thus far, none have been used for upgrading oil sand bitumen.

These processes have been used to maximize liquid yields while minimizing gas and coke formation. The products from fluid coking and Flexicoking are the same as those from delayed coking except for the quantity of coke produced. For both fluid coking and Flexicoking, the gross coke yield is about 24-35 wt% on a fresh feed basis. Since some of the coke is utilized for process heating requirements, the net coke yield is about 70-85 wt% of the gross coke yield [17,18].

The percentage by weight of a component in a mixture is commonly abbreviated as wt%.

5.4.4 Fluid Catalytic Cracking

FCC is the mainstay of most refinery operations. However, this technology has not yet been used in large commercial operations for upgrading heavy oil residues or bitumen. The process is similar to that of thermal cracking but uses catalysts [18]. Preheated feed is sprayed into the base of a vertical pipe where it contacts hot, fluidized catalyst. The hot catalyst serves two purposes: it vaporizes the heavy oil feed and it catalyzes the cracking reactions that reduce the molecular weight of the feed to that of medium API oil.

Catalytic cracking increases the proportion of gasoline produced by cracking naphtha to lighter products in the presence of catalysts.

Catalytic cracking was primarily designed to increase gasoline supplies. In general, it produces less methane and heavier gases and is a more controlled and selective upgrading process than coking. The efficacy of catalytic cracking for residue conversion is somewhat limited due to the fact that large molecules are unable to get into the catalyst pores. In the current implementation of this process for feeds such as the oil sand bitumen, about 20-30% of the feed is treated in the reactor, while the remainder is bypassed. The reactor products are blended with the bypassed stream to produce a 20° API synthetic crude oil, which can be processed by conventional means [26].

5.4.5 Hydroconversion

In a broad sense, hydroconversion includes catalytic and non-catalytic processes in a pressurized hydrogen environment. Hydroconversion is called hydroprolysis when the process does not employ catalysis. Hydroprolysis, originally developed at the University of Utah for the upgrading of Utah oil sands, is a noncatalytic hydrogen addition process that results in little coke formation [20]. This process involves spraying a fine mist of bitumen into a hot chamber using hot hydrogen gas carrier. High temperatures, reactants in the gas phase (bitumen and hydrogen), and low residence times are required. Under optimized conditions, greater than 90% liquid yields have been reported. Hydroprolysis reduces the average molecular weight and improves the H/C ratio of the feedstock.

In Canadian oil sands upgrading, hydroconversion combines catalytic activity with thermal cracking in the presence of a catalyst to convert the vacuum residue to lower boiling fractions. Hydrogen suppresses coke formation and aids in heteroatom removal, including sulfur. Hydroconversion is used by Syncrude for primary upgrading [19].

5.5 Secondary Upgrading Technologies

Secondary upgrading technologies focus on (1) molecular weight reduction, (2) the saturation reactions of ununsaturated heavy distillates produced primarily from bitumen or residues, and (3) the removal of heteroatoms such as sulfur and nitrogen in a high pressure hydrogen environment.

5.5.1 Hydrocracking

Hydrocracking is a catalytic cracking process performed in the presence of high-pressure hydrogen. It is a more severe operation than either hydroconversion or hydrotreating (also called hydrotreatment) in that it requires more hydrogen pressure. Performed over a dual function hydrogenation/cracking catalyst, it is used to reduce the average molecular weight of the hydrocarbon molecules in a fuel [16-19]. In some Canadian upgrading processes, hydrocracking is a secondary upgrading treatment for gas oils and deasphalted feeds (see Section 5.6.1).

5.5.2 Hydrotreatment for Bitumen-Derived Liquids

Bitumen-derived liquids require secondary upgrading as they are comprised predominantly of alkenes and thus have low H/C ratios. The exception would be those liquids produced from hydroconversion. Hydrotreating catalytically stabilizes feedstocks by hydrogenation of unsaturated bonds and removal of sulfur (>90%), nitrogen (>70%), oxygen, halides and trace metals from larger organic chains. Hydrotreating is a relatively low temperature process (see Table 5-5) and employs catalysts similar to those used in hydroconversion [16-19].

Distillates are condensable products and are classified as light (gasoline), middle (jet fuel, diesel) and heavy (fuel oil, paraffinic wax).

Unsaturated hydrocarbons exhibit double or triple bonds between carbon atoms, and are unsaturated with respect to hydrogen.

Bitumen-derived liquids are the distillates from the primary upgrading process.

Alkenes (also called as olefins) are one type of unsaturated hydrocarbon containing at least one carbon-carbon double bond. They are unstable compounds.

Because it produces negligible cracking, hydrotreatment is suitable as a secondary upgrading process. The general practice for bitumens and bitumen-derived liquids in Canadian operations is to coke the liquid first, then follow up with hydrotreatment. In these processes, liquid yields ranging from 65-70% are obtained.

Extensive research on the upgrading of bitumens and bitumen-derived liquids has been performed at the University of Utah [27,28]. Native bitumen and bitumen-derived liquid obtained from the pyrolysis of Utah oil sands were hydrotreated at temperatures between 651°-764°F (344°-407°C) and pressures between 11.0-17.2 MPa. The native bitumen was extracted from the oil sands using toluene as the solvent. Both the native bitumen and the bitumen-derived liquid were subsequently hydrotreated. Properties of the bitumen and of the bitumen-derived liquid before and after hydrotreatment are listed in Table 5-5 [27,28]. The first column lists properties of the native bitumen, while the properties of the pyrolyzed oil sands (e.g. bitumen-derived liquid) and of the bitumen-derived liquid after hydrotreatment are listed in columns two and three, respectively. Simulated distillation is used to determine oil compositions. The measured compositions are reported as carbon number cuts or boiling point cuts, meaning the fraction of the material that boils between the two listed temperatures. Properties of upgraded (hydrotreated) bitumen are not included in the table but can be found in [27,28].

The results in Table 5-5 show that conventional upgrading technologies could be used to convert bitumen derived from Utah oil sands into useful products [27,28]. For comparison, synthetic (hydrotreated) crude from Canadian oil sands has an API gravity of 32° and a residue fraction (> 1000°F/538°C) of nearly zero. Compositions of the cuts from synthetic Canadian crude are also within 1-2% of the composition shown in Table 5-5 for the hydrotreated Utah bitumen-derived liquid [29].

A pascal (Pa), an SI unit of pressure, is equivalent to one newton per square meter. A MPa is one million Pa. One MPa = 145 psi.

Simulated distillation is a gas chromatographic procedure that produces results similar to distillation without incurring the time and expense of distillation.

Table 5-5. Properties of bitumen and bitumen-derived liquids from the Whiterocks, Utah oil sands deposit.

	Native bitumen	Pyrolyzed bitumen-derived liquids	Hydrotreated bitumen-derived liquid
API	11.9	18.5	35
CCR, wt%	8.1	4.7	NA
Pour point, °F	149	43	7
Simulated distillation			
Volatilities, wt. %	40.5	82.2	97.4
IBP, °F	421	286	206
IBP – 399°F, wt%	-	4.7	12.5
399-651°F, wt%	4.9	18.5	40.0
651-1000°F, wt%	35.6	59.0	34.9
> 1000°F, wt%	59.5	17.8	2.6
Elemental analysis			
C, wt%	85.1	86.0	86.7
H, wt%	12.3	11.1	13.3
N, wt%	1.2	1.1	43 ppm
S, wt%	0.4	0.3	16 ppm
O, wt%	1.1	1.5	0
Ni, ppm	67	9	NA
V, ppm	< 5	< 1	NA
H/C ratio	1.73	1.55	1.84

Source: D.C. Longstaff et al., *Hydrotreating the Bitumen-Derived Hydrocarbon Liquid Produced in a Fluidized-Bed Pyrolysis Reactor, 1992*; D.C. Longstaff et al., *Hydrotreatment of Bitumen from the Whiterocks Oil Sands Deposit, 1994*

5.5.3 Hydrotreatment for Shale Oil

A typical shale oil has high nitrogen content (1.5-2.7%) and moderately high sulfur content (0.36-0.66%) [30]. It is essential to remove nitrogen and sulfur prior to refining to end products. The hydrotreatment process involves reacting raw shale oil with hydrogen in the presence of a catalyst. This hydrogenation converts sulfur to hydrogen sulfide, nitrogen to ammonia, oxygen to water, olefin hydrocarbons to their paraffin equivalents, and long-chain molecules to smaller molecules [31]. The hydrogenation reactions can take place in a fixed bed reactor, a fluidized bed reactor, or an ebulliating bed reactor. In an ebulliating bed reactor, a mixture is injected into the bottom of the reactor at a sufficient velocity to cause catalyst ebulliation. This movement reduces the likelihood that the bed will become plugged by coke or by liquid tars from the coking process. It also allows spent catalyst and coke to be removed and fresh catalyst to be added.

Hydrotreatment produces upgraded products of the highest quality, but it is relatively expensive. The use of fixed bed reactors would probably be confined to the treatment of streams from an initial fractionation step; fluidized bed or ebulliating bed processes could be used for either fractionator products or for the raw shale oil [15-18,31].

Conradson Carbon Residue (CCR) provides an index on how well the oil can be refined.

Volatilities or distillable components are defined here as all the fuel components with boiling points < 1000°F (538°C) .

Initial Boiling Point (IBP) is the fluid temperature at which the first liquid drop falls into a graduated cylinder from a condenser connected to a distillation flask.

Elements include carbon (C), hydrogen (H), nitrogen (N), sulfur (S), oxygen (O), nickel (Ni), and vanadium (V).

Parts per million is abbreviated as ppm.

Paraffinic hydrocarbons contain only single bonds and are saturated with respect to hydrogen.

Ebulliation is a boiling motion.

Fractionation is the separation of a certain quantity of material from a given feed through distillation or solvent extraction.

5.6 Enhanced Upgrading

There is an increased recognition that using all components of the feed may be necessary to reduce hydrogen consumption from natural gas and to reduce process energy needs. Enhanced upgrading processes have been conceptualized to realize some of these needs.

5.6.1 Solvent Deasphalting and Supercritical Extraction

Solvent deasphalting and supercritical extraction are both asphaltene rejection technologies. The feedstock is mixed with a paraffinic solvent in both processes. The solvent may not be at supercritical conditions in the case of solvent deasphalting but is always at supercritical conditions in the case of supercritical extraction. Supercritical extraction minimizes energy costs as the separation of the extract from the solvent is easy above the critical temperature. Nevertheless, solvent recovery is the major utility cost [32]. Operating conditions can be very similar for the two processes, and both produce a light fraction (extract) and leave a heavier residue fraction. The residue contains a significant amount of asphaltenes. The solvent to oil ratio is high (4:1 or greater) as higher ratios yield better separation of heavy residue [32]. The extract is significantly upgraded.

Supercritical extraction is being seriously considered for the partial upgrading of bitumen to lighter components with the goal of reducing the volume of heavy oil requiring hydrocracking and hydrotreatment. Figure 5-3 shows the cumulative weight fraction distributions for simulated distillations of the extracts from a supercritical extraction process involving a Utah bitumen. The bitumen plot shown in the figure lies between that of the residue (fraction remaining after all the extractions) and of the extracted fractions. The lightest components are extracted first as seen from the distribution for fraction 1. The steep curve for fraction 1, ending at a cumulative fraction of almost 1 while still in the low carbon number range, indicates that no heavy components are left in the material after the extraction. Subsequent extraction fractions (fractions 3 and 6) show the presence of heavier material.

Figure 5-3. Conceptual simulated distillation curves for the extract, bitumen and the residue after supercritical extraction.

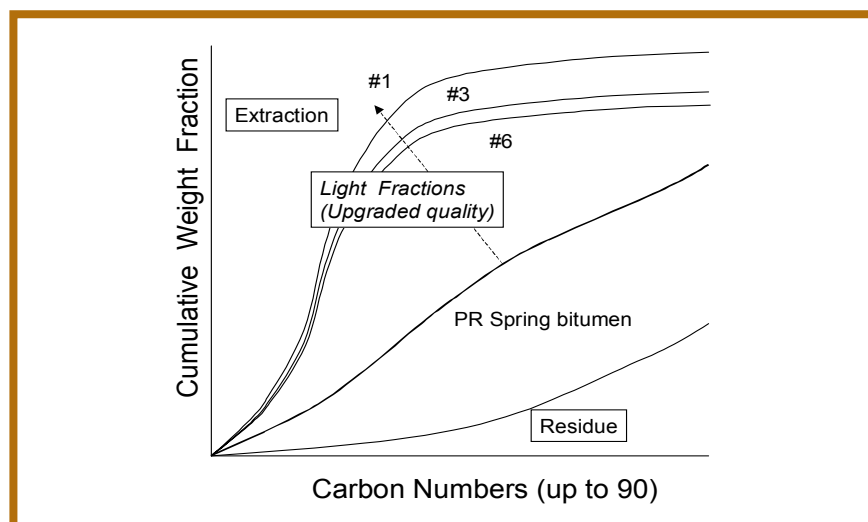

Source: R. Wajnryb et al., *Supercritical Fluid Extraction of Bitumens from Utah Oil Sands*, 1998

Paraffinic solvents used are C3-C6, which are propane to hexane.

Supercritical conditions occur when the temperature and pressure are above the thermodynamic critical point of a given fluid. At supercritical conditions, the distinction between gas and liquid phases disappears and the fluid has properties of both.

Supercritical fluid extraction of Utah bitumens has been explored using supercritical propane. The extract yields and the atomic H/C ratio of the heavy oil residues from experiments at five different operating conditions are presented in Table 5-6 [20,24,32]. The results show that the cumulative extraction yields increase with an increase in pressure at constant temperature and decrease with an increase in temperature at constant pressure. Increase in solvent density also results in a yield increase.

Table 5-6. Extraction yields and properties from the supercritical propane extraction of four Utah bitumens.

Extraction Condition	224°F (107°C) 5.6 MPa	300°F (149°C) 10.4 MPa	224°F (107°C) 10.4 MPa	224°F (107°C) 10.4 MPa	224°F (107°C) 14.3 MPa
Propane density (g/cc)	0.533	0.545	0.553	0.566	0.569
Extract yield (wt%)					
Whiterocks	20.0	24.0	39.0	40.0	48.0
Asphalt Ridge	13.4	18.2	24.5	31.3	31.4
PR Spring	8.8	15.7	20.8	23.0	31.7
Sunnyside	12.0	11.2	14.8	22.4	23.7
H/C ratio of Residual phase					
Whiterocks (1.56)	1.52	1.53	1.49	1.49	1.46
Asphalt Ridge (1.6)	1.50	1.52	1.47	1.44	1.50
PR Spring (1.56)	1.51	1.50	1.47	1.44	1.46
Sunnyside (1.49)	1.43	1.46	1.41	1.39	1.36

The SI (International System of Units) units for density are grams per cubic centimeter or g/cc.

Source: A.G. Oblad et al., *Tar Sand Research and Development at the University of Utah, 1987*; A.G. Oblad et al., *The Extraction of Bitumen from Western Oil Sands, Volume I, 1997*; R. Wajnryb et al., *Supercritical Fluid Extraction of Bitumen from Utah Oil Sands, 1998*

The data in Figure 5-3 and Table 5-6 are relevant because supercritical extraction/solvent deasphalting are being considered in conjunction with technologies such as gasification to provide an energy-integrated, sustainable upgrading option for converting oil sands bitumen to refinery-ready feedstocks.

5.6.2 Gasification

In the Canadian oil sands industry, the sharp increase in the use of natural gas as a source of hydrogen and of energy in the upgrading process has led to the exploration of gasification as an alternative source. Gasification of residues (atmospheric and vacuum) performed at higher temperatures (> 1832°F/1000°C) produces synthesis gas (syngas), carbon black and ash. The most common gasification technology is steam reforming. The residue, a carbon rich material, is reacted under catalytic conditions with steam to produce syngas. Steam reforming is endothermic and requires external energy. It is combined with partial oxidation of the residue, which is an exothermic process, so external heat is not required. This combined process results in a heat integrated system where syngas compositions can be optimized.

5.6.3 Novel Hydrovisbreaking and Fast Pyrolysis

Research is being performed on some novel upgrading methods. In hydrovisbreaking, the feed is reacted with hydrogen in the presence of a hydrogen donor solvent. Both catalytic and noncatalytic versions of the process are being evaluated. Thermal cracking in short residence time reactors to yield partially upgraded products is also being studied [15,33].

5.7 Summary

In this section, available upgrading technologies were briefly reviewed, including emerging technologies. Some data on the quality of the upgraded product from Utah oil sands and from a representative shale oil were provided to show that it is possible to produce refinery-grade crude oil from U.S. unconventional fuel resources.

Upgrading considerations will be very important to the commercialization of unconventional oil resources in North America. The Canadian experience has shown that existing technologies (e.g. coking followed by hydrotreatment) are not sustainable for a variety of reasons and new technologies would need to be developed and commercialized. The value of the product and the commercial viability of the entire industry will depend on a number of complex, interconnected issues such as the cost of production, the cost of upgrading, environmental sustainability and the overall market dynamics of both local and global markets.

5.8 References

- [1] Berry Petroleum. 2006 Form 10-K. <http://www.bry.com/index.php?page=investor> (accessed June 18, 2007).
- [2] Canadian Association of Petroleum Producers. *Bitumen Pricing Methodology for SEC Reserves Disclosure*; Canadian Association of Petroleum Producers, Sept. 2005. Also available at <http://www.capp.ca/raw.asp?x=1&dt=NTV&dn=91581>.
- [3] Heidrick, T.; Bilodeau, V.; Godin, M. *Oil Sands Research Inventory*; Alberta Energy Research Institute: Edmonton, Alberta, March 2004. Also available at http://www.aeri.ab.ca/sec/new_res/docs/Oil_Sands_Public_Research_27Apr07.pdf.
- [4] Gossen, S. Partial Upgrading of Heavy Oil and Bitumen: Strategic Value in Western Canada. *Canadian Heavy Oil Association Meeting*, Calgary, Alberta, May 8, 2002. Also available at <http://www.ensyn.com/info/08052002.htm>.
- [5] Strycker, A.R.; Wadkins, R.; Olsen, D.K.; Sarkar, A.K.; Ramzel, E.B.; Johnson, W.I.; Pautz, J. *Feasibility Study of Heavy Oil Recovery in the United States*; NIPER/BDM-0225; BDM-Oklahoma, Bartlesville, OK, March 1996.
- [6] Alberta Department of Energy. *Alberta's Oil Sands Fiscal System – Historical Context and System Performance*; Technical Royalty Report OS#1; Alberta Department of Energy, 2007. Also available at http://www.energy.gov.ab.ca/docs/albertaenergy/TechReport-1_OilSands.pdf.
- [7] Government of Alberta. Oil Sands. <http://www.energy.gov.ab.ca/89.asp> (accessed June 18, 2007).
- [8] IOGCC Governor's Task Force. *Rocky Mountain Region Crude Oil Market Dynamics*; Interstate Oil and Gas Compact Commission, January 2007. Also available at <http://www.iogcc.state.ok.us/PDFS/RM-Crude-Oil-Market-Dynamics.pdf>.
- [9] Government of Alberta, Energy. The Hydrocarbon Upgrading Task Force. <http://www.energy.gov.ab.ca/3044.asp> (accessed June 18, 2007).
- [10] National Centre for Upgrading Technology. <http://www.ncut.com> (accessed June 18, 2007).
- [11] Alberta Research Council. Upgrading and Refining. <http://www.arc.ab.ca/index.aspx/ARC/3053> (accessed June 18, 2007).

- [12] Bruce, G.W. *Alberta Oil Sands in the Global Marketplace – Getting There?* 4th Upgrading and Refining of Heavy Oil, Bitumen and Synthetic Crude Oil Conference, Edmonton, Alberta, September 25-27, 2006.
- [13] Flint, L. *Bitumen Recovery Technology: A Review of Long Term R&D Opportunities*, LENE Consulting Limited, 2005.
- [14] Alberta Energy Research Institute; *2007-12 Strategic Business Plan*; Alberta Government, AERI; p 12. Also available at http://www.aeri.ab.ca/sec/new_res/docs/AERI_2007-12_Business_Plan.pdf.
- [15] Rana, M.S.; Sámano, V.; Ancheyta, J.; Diaz, J.A.I. A Review of Recent Advances on Process Technologies for Upgrading of Heavy Oils and Residua. *Fuel* **2007**, *86*, pp 1216-1231.
- [16] Gray, M. Research Challenges for Sustainable Oil Sands Production. Research presentation to the Utah Heavy Oil Program, University of Utah, March 15, 2007.
- [17] Gary, J.H.; Handwerk, G.E.; Kaiser, M.J. *Petroleum Refining: Technology and Economics*, 5th ed.; Taylor & Francis: Boca Raton, FL, 2007.
- [18] Speight, J.G.; Özüm, B. *Petroleum Refining Processes*; Marcel Dekker, Inc.: New York, 2002.
- [19] The Encyclopedia of Earth. Cracking. <http://www.eoearth.org/article/Cracking> (accessed June 18, 2007).
- [20] Oblad, A.G.; Bunger, J.W.; Hanson, F.V.; Miller, J.D.; Ritzma, H.R.; Seader, J.D. Tar Sand Research and Development at the University of Utah. *Annual Review of Energy* **1987**, *12*, pp 283-356.
- [21] Culberson, S.F. The Outlook for Oil Shale. *Journal of Petroleum Technology* **1982**, pp 965-972.
- [22] Shell Oil Company. Welcome to the Mahogany Research Project. http://www.shell.com/home/Framework?siteId=us-en&FC2=/us-en/html/iwgen/leftnavs/zzz_lhn4_4_0.html&FC3=/us-en/html/iwgen/shell_for_businesses/exploration_production_shared/mahogany_shared/dir_mahogany.html (accessed October 1, 2006).
- [23] U.S. Office of Technology Assessment. *An Assessment of Oil Shale Technologies, Volume I*; PB80-210115; Congress of the United States: Washington, D.C., 1980.
- [24] Oblad, A.G.; Dahlstrom, D.A.; Deo, M.D.; Fletcher, J.V.; Hanson, F.V.; Miller, J.D.; Seader, J.D. *The Extraction of Bitumen from Western Oil Sands, Volume I*; DOE/MC/30256-99-Vol.1D; U.S. Department of Energy, Office of Fossil Energy: Washington, D.C., November 1997.
- [25] Hammond, D.G.; Lampert, L.F.; Mart, C.J.; Massenzio, S.F.; Phillips, G.E.; Sellards, D.L.; Woerner, A.C. Review of FLUID COKING™ and FLEXICOKING™ Technologies. Sixth Topical Conference on Refining Processing Tutorial on Resid Upgrading, AIChE Spring National Meeting, New Orleans, LA, March 2003.
- [26] Couch, K.; Seibert, K.; Johnson, D.; Hedrick, B.; McGehee, J. A New Approach to Heavy Oil and Bitumen Dilution. 4th Upgrading and Refining of Heavy Oil, Bitumen, and Synthetic Crude Oil Conference, September 25-27, 2006, Edmonton, Canada.
- [27] Longstaff, D.C.; Deo, M.D.; Hanson, F.V.; Oblad, A.G.; Tsai, C.H. Hydrotreating the Bitumen-Derived Hydrocarbon Liquid Produced in a Fluidized-Bed Pyrolysis Reactor. *Fuel* **1992**, *71*(12), pp 1407-1419.
- [28] Longstaff, D.C.; Deo, M.D.; Hanson, F.V. Hydrotreatment of Bitumen from the Whiterocks Oil Sands Deposit. *Fuel* **1994**, *73*(9), pp 1523-1530.
- [29] Brierly, G.R.; Gembicki, V.A.; Cowan, T.M. Changing Refinery Configuration for Heavy and Synthetic Crude Processing; UOP LLC: Des Plaines, IL, 2006. Also available at <http://www.uop.com/objects/ChangingRefineryConfiguration.pdf>.
- [30] Burnham, A.K.; McConaghy, J.R. Comparison of the Acceptability of Various Oil Shale Processes. Sixth Topical Conference on Natural Gas Utilization, AIChE Spring National Meeting, Orlando, FL, April 23-27, 2006.
- [31] Bunger, J.W.; Crawford, P.M. Is Oil Shale America's Answer to Peak-Oil Challenge?

- Oil & Gas Journal* **2004**, 102(30), pp 16-24.
- [32] Wajnryb, R.; Subramanian, M.; Hanson, F.V. Supercritical Fluid Extraction of Bitumens from Utah Oil Sands. *Fuel Processing Technology* **1998**, 55(1), pp 35-53.
- [33] Session 1: New Technologies for Bitumen Upgrading. 4th Upgrading and Refining of Heavy Oil, Bitumen, and Synthetic Crude Oil Conference, September 25-27, 2006, Edmonton, Alberta.

6

Economic and Social Issues Related to Unconventional Oil Production

6 Economic and Social Issues Related to Unconventional Oil Production

Economic and social issues associated with oil production from heavy oil, oil sands and oil shale can be viewed from various perspectives. From the producing companies' perspective, the most important economic factors are the higher cost of production as compared to conventional oils of lighter gravity and the risk associated with new technologies. For example, production of oil sands and oil shale in the Rocky Mountain region will likely require additional pipeline, refinery and electrical generation capacity. From the perspective of local communities near resources of significant size, construction of large oil production facilities will result in sizeable increases in employment, driving in-migration to primarily rural areas. There is a strong possibility of local infrastructure such as schools and housing being strained by the rapid population increase.

Because the petroleum industry operates in a worldwide commodity market with transparent pricing, the market sets the price received. Petroleum derived from heavy oil, oil sands and oil shale must achieve profitability in a market dominated by conventional crude oil. The future of these energy sources is strongly linked to the future price of crude oil. In constant dollars, the price of crude oil was at an all-time peak in the early 1980s at over \$80 per barrel, expressed in dollars with a 2005 purchasing power as seen in Figure 6-1 [1]. The price then dropped precipitously to the \$20-\$30 per barrel range for the latter half of the 1980s and remained in that range until 1998, when the price dropped again to \$16 per barrel. Since 1998, prices have rebounded to \$66 per barrel in 2007.

Constant dollars take into account inflation so that they have equal purchasing power.

Figure 6-1. Real price of imported, low-sulfur crude oil with forecasts to 2030.

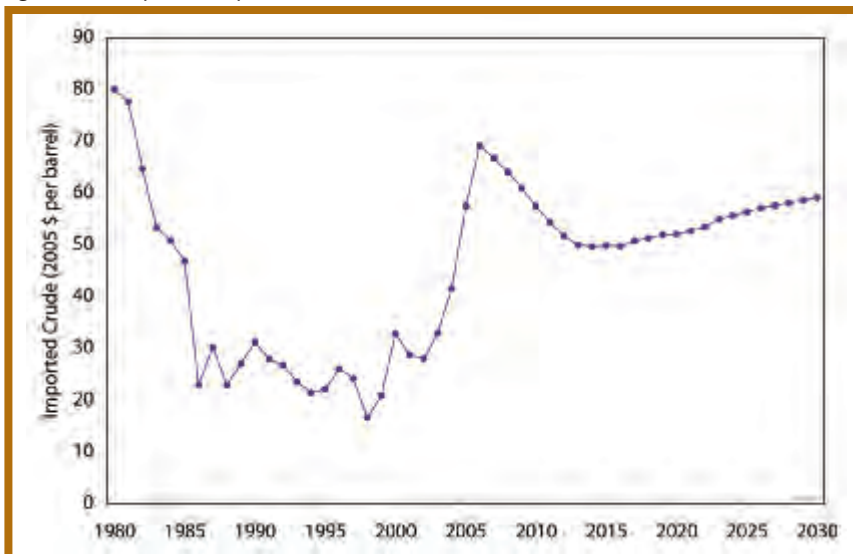

Source: Energy Information Administration, Annual Energy Outlook 2007.

Note: Data converted from dollars per million BTUs at the rate of 5.8 million BTUs per barrel.

The 2007 Annual Energy Outlook forecasts a gradual decrease in the price of crude oil through 2015, as additional exploration and development brings new supplies to the world market [1]. After 2015, real prices are forecast to increase due to rising worldwide demand and higher-cost supplies. In 2030, the average real price of imported

low-sulfur crude oil is forecast to be over \$59 per barrel, or about \$95 per barrel in nominal terms assuming a 2% inflation rate. Given this forecast for a continued high crude oil price, it is highly likely that profitable operating economics will lead to additional development of heavy oil, oil sands and oil shale resources in the United States.

Worldwide demand for crude oil is projected to grow from 80 million barrels per day in 2003 to 98 million barrels per day in 2015 and 118 million barrels per day in 2030. To meet this projected increase in demand, total petroleum supply in 2030 will need to increase by 38 million barrels per day from the 2003 level [2].

Finally, world oil trading patterns will change substantially as China and the other countries of non-OECD Asia fuel their growth (and accompanying oil demand) by taking an increasing share of the world's oil imports. China's petroleum imports are expected to grow fourfold from 2003 to 2030, with much of the increase coming from Persian Gulf suppliers. In 2003, China imported 0.9 million BOPD of oil from Persian Gulf OPEC members. In 2030, China's Persian Gulf imports are projected to total 5.8 million BOPD. The rising dependence of China on Middle Eastern oil supplies has geopolitical implications both for relations between the two regions and for the oil-consuming world as a whole [2].

6.1 Operating Economics

The degree to which the economics of the heavy oil, oil sands and oil shale resources are understood varies widely and is dependent on the extent to which the resource has been commercialized. Heavy oil is presently produced in large quantities in southern California and the economics of this industry are well understood. There is a large oil sands industry in Alberta from which to study economic data, but the U.S. oil sands deposits, located predominantly in Utah, have different characteristics than those in Alberta as addressed in Section 4.2 of this report. Hence, the economics of a Utah oil sands industry may be noticeably different than the Canadian experience. Oil shale is the least understood of the three resources, with new technologies having the potential to drastically alter the economics. As with any natural resources project, the economics of a specific operation can be highly dependent upon the individual deposit and on the extraction process employed.

A common factor in many of the heavy oil, oil sands, and oil shale production and upgrading processes is the use of natural gas, both for energy and as a source of hydrogen. Natural gas, however, has more than tripled in price from 1980 to 2005. Given the large quantities of natural gas that are projected as necessary for future oil sands and oil shale development, this additional cost pressure may affect the long term economic viability of these industries. Also, the future availability of natural gas and its multiple competing uses raise the question of whether producing petroleum from unconventional sources is the most economically rational use of natural gas.

Almost three-quarters of the world's natural gas reserves are located in the Middle East and Eurasia. Russia, Iran, and Qatar combined accounted for about 58% of the world's natural gas reserves as of January 1, 2006. Currently, Canada is the source of 90% of U.S. natural gas imports, representing about 15% of U.S. natural gas consumption. However, the decline of Canada's largest gas-producing basin, the Western Sedimentary Basin, coupled with projected growth in Canada's domestic gas consumption, will

Real prices refer to constant dollars with equal purchasing power.

Nominal prices refer to current prices without accounting for inflation or deflation.

The Organisation for Economic Co-operation and Development (OECD) is a group of 30 countries that promotes democracy and a market economy.

BOPD refers to barrels of oil per day.

Organization of the Petroleum Exporting Countries (OPEC) is comprised of twelve oil-producing countries: Algeria, Angola, Indonesia, Iran, Iraq, Kuwait, Libya, Nigeria, Qatar, Saudi Arabia, United Arab Emirates, and Venezuela.

In nominal prices, natural gas rose from \$1.59 per thousand cubic feet in 1980 to \$7.51 per thousand cubic feet in 2005.

leave less Canadian natural gas available for export to the United States. Consequently, the United States will be forced to rely more heavily upon unconventional and higher cost natural gas sources such as coalbed methane production, shale gas, deep gas, and tight gas [2]. Another source of natural gas, imported liquefied natural gas (LNG), may be cheaper than domestic unconventional gas, as evidenced by a recent large increase in U.S. LNG imports.

6.1.1 Heavy Oil

This section summarizes data on operating costs, capital costs, and the economics of production of heavy oil resources. The operating and capital costs associated with steam injection, the main technology currently in use for producing heavy oil (see Section 4.1), are relatively well understood [3,4].

Heavy oil is currently being produced on a commercial scale in the United States, primarily in California. Nevertheless, California production has dropped from just over 650,000 BOPD in 1992 to about 450,000 BOPD in 2004 (see Figure 4-1). Both Canada and Mexico also report significant production of heavy oil, but both countries use definitions of heavy oil that vary from that used in this report (see Section 3). Pemex, the Mexican state oil company, reported production of 2.4 million barrels per day of heavy crude oil during 2005 [5]. Pemex defines heavy oil as that with an API gravity of less than 27°. Most of the heavy oil produced in Mexico is Maya crude with an API gravity of 22° [6]. Similarly, the Canadian Association of Petroleum Producers (CAPP) reported that Canada produced 526,000 barrels per day of heavy oil in 2005, but CAPP defines heavy oil as that with an API gravity of less than 28° [7].

Heavy oil must compete with lighter grades of crude oil. Different crude oils command different prices with prices set by the marketplace. The price of West Texas Intermediate (WTI) crude oil has risen dramatically over the past several years, from a low of less than \$20 per barrel at the end of 2001 to over \$70 per barrel in October 2006 before recently pulling back, as seen in Figure 6-2 [8]. In the same time period, the price for domestic crude with an API gravity of less than 20° has averaged 80% of the price of WTI crude. More specifically, the price of heavy crude from California trades at a discount to WTI crude, and the discount has recently widened. During 2003, California 13° API heavy crude oil traded at a \$5.66 per barrel discount to WTI crude. By 2005, this discount had widened to \$12.34 per barrel [9]. This price discount is driven by the market for oil and is influenced by both worldwide demand and local factors such as pipeline and refinery capacity; it does not represent the cost of the additional refining necessary for heavier oils.

Coalbed methane is natural gas that exists in coal deposits. Shale gas is contained in shale and other fine-grained sedimentary rocks. Deep natural gas is contained in deposits greater than 15,000 feet (4,572 meters) below the surface. Tight natural gas is trapped in unusually impermeable, hard and non-porous rock and is extracted through techniques such as fracturing and acidizing.

West Texas Intermediate (WTI) refers to a crude stream produced in Texas and Oklahoma that is the most common reference or “marker” for pricing crude oil and, along with several other domestic and foreign crude streams, is acceptable for settling New York Mercantile Exchange contracts for light, sweet crude oil.

Figure 6-2. Price of WTI and less than 20° API gravity crude.



Source: Energy Information Administration, *Domestic Crude Oil First Purchase Prices by Crude Stream*, May 2007

While the market price for heavy oil is consistently lower than that for the lighter crude oils, the production costs are higher. Nevertheless, companies are increasing steam injection activities due to high oil prices. For example, Carrizo Oil & Gas, Inc. resumed steam injection operations at the Camp Hill Field in east Texas at the beginning of 2006, despite the high operating cost of \$68.99 per barrel. The company previously operated a steam injection operation at the site in the mid 1990s but discontinued operations due to low profitability [10]. In 2005, Berry Petroleum initiated steam injection at the Poso Creek Field in the San Joaquin Valley Basin and in 2006 converted leases in the Placerita Field in the Los Angeles Basin to steam injection [11]. Similarly, Ivanhoe Energy initiated a steam injection operation in Wyoming during 2004 [3]. Despite this increase in steam injection operations, the new operations are not currently of sufficient size to reverse the long-term decline in production noted in Section 4.1.

The three factors controlling steam injection economics are (1) oil price, (2) the price of energy to generate steam, and (3) the amount of recoverable oil in place using steam injection technology. The critical parameter that links these three factors and determines the profitability of producing heavy oil is the steam to oil ratio (SOR). While engineering can aid in optimizing this ratio, geology establishes the baseline SOR and the ultimate success of a project. For instance, if an oil reservoir is overlain with a gas cap, the steam usually moves preferentially through the gas and little steam contacts the oil. Similarly, if a reservoir lies above an aquifer, the steam may enter the aquifer and the heat will be dissipated [4]. In recent years, the SOR in California's Midway-Sunset Field, the largest heavy oil producer in the country, has varied from under three to just over four. In 2000, the field-wide SOR was 3.44, followed by a drop to 2.74 in 2001. Since then, the SOR has gradually increased, with a value of 4.02 reported in 2005 [12-17]. Elsewhere, Berry Petroleum averaged 15,972 barrels per

SOR is the amount of water equivalent barrels injected per barrel of oil produced.

day of heavy oil production and injected an average of 81,264 barrels per day of steam for an average SOR of 5.09 [11]. The amount of steam injected directly impacts the amount of natural gas required for steam injection, so a rising SOR directly increases the cost of operations.

Steam injection technology requires higher capital costs than conventional oil recovery due to the steam injection equipment. During 2006, Plains Exploration and Production Company drilled 141 wells in the San Joaquin Basin and spent \$116 million on capital projects, for an average of \$823,000 per well [18]. The capital expenditures include the cost of drilling wells and of purchasing all equipment necessary to operate the steam injection operations, providing an estimate of the total capital investment necessary for heavy oil recovery with steam. Additionally, due to increased demand, the cost of drilling oil wells has tripled over the past ten years in both real and nominal dollars as shown in Table 6-1 [19,20].

Table 6-1. Costs applicable to steam injection, 1990-2004.

	Drilling Cost per Well		Drilling Cost per Foot		Wellhead Natural Gas, MCF	
	Nominal Dollars	2005 Dollars	Nominal Dollars	2005 Dollars	Nominal Dollars	2005 Dollars
1990	\$321,800	\$442,269	\$69.17	\$95.06	\$1.71	\$2.35
1991	346,947	460,714	73.75	97.93	1.64	2.18
1992	362,260	470,240	69.50	90.22	1.74	2.26
1993	356,608	452,449	67.52	85.67	2.04	2.59
1994	409,471	508,710	70.57	87.67	1.85	2.30
1995	415,814	506,231	78.09	95.07	1.55	1.89
1996	341,000	407,425	70.60	84.35	2.17	2.59
1997	445,613	523,701	90.48	106.34	2.32	2.73
1998	566,041	657,936	108.88	126.56	1.96	2.28
1999	782,980	897,113	156.45	179.26	2.19	2.51
2000	593,387	665,389	125.96	141.24	3.68	4.13
2001	729,099	798,414	153.72	168.33	4.00	4.38
2002	882,837	950,177	194.55	209.39	2.95	3.18
2003	1,037,274	1,094,151	221.13	233.26	4.88	5.15
2004	1,441,812	1,481,921	298.45	306.75	5.46	5.61
2005	na	na	na	na	7.51	7.51

Nominal costs were converted to real costs using the Gross Domestic Product Implicit Price Deflator.

MCF refers to one thousand cubic feet of gas, measured at one atmosphere of pressure and 60° F.

Source: Energy Information Administration, Annual Energy Review 2005; Energy Information Administration, Natural Gas Prices, December 2006

Operating costs are also higher for steam injection than for conventional oil recovery and are inextricably linked to the price of natural gas, which is generally used to generate steam. In southern California, each \$1.00 fluctuation in the price of natural gas changes operating costs by approximately \$1.60 per barrel [11]. Natural gas has seen nationwide wellhead price increases from \$1.71 per MCF in 1990 to \$7.51 per MCF in 2005 in nominal terms. Equally significant, the price of natural gas is also rising in real terms. Furthermore, many reservoirs amenable to steam injection are in unconsolidated deposits and are susceptible to sand production, requiring more frequent workovers. High-pressure steam also increases the likelihood of casing or tubing failure in older wells and faster corrosion of well equipment [4].

Workovers are major remedial actions required to maintain oil production. Sand production refers to recovering sand along with crude oil from a well. The sand is erosive and increases equipment wear.

Past variations in the prices of both natural gas and crude oil have altered production at heavy oil operations in the United States. The California energy crisis during 2001 had a detrimental effect on production from the San Joaquin Basin. When natural gas prices rose dramatically during the first part of 2001, AERA Energy, the largest oil producer in California at the time, cut steam injection at the Beldridge Field. Production dropped by 8,000 barrels per day or about 18%. The company's cash flow from the project turned negative for several months until natural gas prices moderated later in the year [21].

The volatile price of natural gas in recent years has also complicated heavy oil production economics. Since the beginning of 2001, the price of natural gas delivered to industrial users in California has varied from a low of \$3.31 per MCF during October, 2001 to a high of \$13.39 per MCF in November, 2005. The latest available data indicates that industrial users of natural gas in California paid \$9.08 per MCF during February, 2007 [22].

To demonstrate the influence of crude oil and natural gas prices on steam injection operations, the internal rates of return (IRR) of a single inverted nine-spot well pattern under different price structures are given in Figure 6-3. IRR was computed using the parameters specified in Table 6-2. If the cost of natural gas is \$5 per MCF and the selling price of crude oil is \$40 per barrel, the IRR is 6.5%. This rate of return is too low to justify investment in heavy oil operations. If the price of crude oil increases to \$55 per barrel, the corresponding rate of return rises to 15.6% at \$5 per MCF of natural gas. If the price of crude oil rises to \$70 per barrel, the IRR at \$5 per MCF is 23.9%. If the price of natural gas increases to \$9 per MCF, the IRR for \$55 per barrel oil drops to 13.4%. These calculations were performed assuming that the nine-spot well pattern was part of a larger operation. A project with an ongoing drilling program over a larger area, or with different parameters than those outlined in Table 6-2, would have different internal rates of return.

Internal Rate of Return (IRR) refers to the interest rate necessary to generate the future cash flows of a project based on the initial investment.

A nine-spot pattern has a single injection well surrounded by eight producing wells. The producing wells are arranged in a square, with wells located on the corners of the square and at the mid-points of the sides of the square.

Figure 6-3. Internal rates of return for a single inverted nine-spot well pattern.

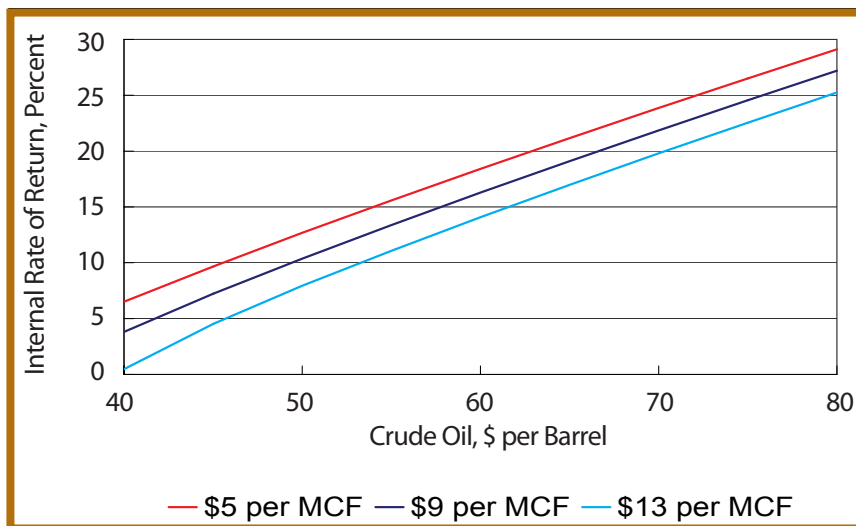

Source: Utah Heavy Oil Program

Table 6-2. Steam injection economic parameters considered for internal rate of return calculations.

Parameter	Value	Parameter	Value
Capital	\$1,500,000	Final Steam to Oil Ratio	5
Pattern	Inverted nine-spot	Royalty Rate	16.67%
Recovered Oil	100,000 barrels	Federal Tax Rate	35%
Pattern Life	10 years	State Tax Rate	8.84%
Initial Steam to Oil Ratio	3	Depreciation Method	Units of Production

Source: Utah Heavy Oil Program

Many of the southern California producers use cogeneration facilities to produce steam and sell the electricity to local utilities. Revenue from selling electricity improves project profitability. During 2005, 37 cogeneration facilities were operated by 10 oil companies in Kern County, California. Of these, 34 were gas-fired and 3 were coal-fired. The cogeneration facilities had a total generating capacity of 1,753.5 MW in 2005 [17].

6.1.2 Oil Sands

This section summarizes data on operating costs, capital costs, and the economics of oil sands production. Most of the knowledge base for producing bitumen and synthetic crude oil from oil sands comes from Canada, where oil sands have been processed on an industrial scale in northern Alberta since the early 1980s.

Significant capital has already been invested in the Alberta oil sands industry, and announced projects indicate additional spending in the future. Between 1996 and 2004, the Alberta oil sands industry spent an estimated \$25 billion on new projects. Survey work conducted by the Canadian Association of Petroleum Producers and the Regional Issues Working Group indicate that the Alberta oil sands industry plans on spending \$57 billion in the 2006-2011 time frame and as much as \$71.4 billion in the decade from 2006-2016 [23].

Early production costs are estimated at C\$35 per barrel. Production costs include capital costs, operating costs, taxes, royalties and a rate of return on investment. Efficiency gains and increased economies of scale between the early 1980s and late 1990s dropped the operating costs from C\$30 per barrel to less than C\$13 per barrel for an integrated mining and upgrading operation. In the 1990s, two major improvements resulted in large reductions in operating costs. The first improvement was replacing draglines and bucketwheel reclaimers with massive mining trucks and power shovels. This change in equipment resulted in increased flexibility, lower maintenance and improved energy efficiency. Second, hydrotransport systems replaced conveyor belts for transporting oil sands to the processing plants. In 2000, the Canadian National Energy Board predicted that additional efficiency gains would further decrease the cost to C\$10 by 2004 and to the C\$8-\$9 per barrel range by 2015 [24].

The term C\$ refers to Canadian dollars. In this report, a dollar sign (\$) refers to U.S. dollars unless otherwise indicated.

Bucketwheel reclaimers are large mining equipment that dig using buckets attached to a wheel.

Hydrotransport refers to slurry pipelines in which the solid material is moved in a stream of water.

However, in recent years the cost of oil sands production has risen, primarily due to rising energy costs and to higher capital costs [25]. As with heavy oil, the operating costs for bitumen and synthetic crude oil are linked to the price of natural gas which, as noted previously, has increased dramatically over the past several years. Natural gas is used for generating steam in two commonly-used in situ recovery methods, Cyclic Steam Stimulation (CSS) and Steam Assisted Gravity Drainage (SAGD) (see Section 4.2.3). Natural gas is also used for upgrading bitumen to synthetic crude oil. It is a source of heat and, in hydrocracking and hydrotreating (see Section 5), a source of hydrogen. The rule of thumb in the Canadian oil sands industry is that one MCF of natural gas is necessary to produce one barrel of bitumen [25]. The sharp increase in steel prices since 2002 is responsible for a major portion of the higher capital costs.

The present total cost of an integrated mining and upgrading operation is estimated at \$32-\$35 per barrel as noted in Table 6-3 [26]. The total cost includes all costs, e.g. operating costs, capital costs, taxes, royalties and a rate of return on investment. Also broken out in Table 6-3 are the operating costs, which reflect the cash cost of the operation.

Table 6-3. Production costs of Canadian oil sands, 2005 dollars per barrel.

Production Process	Product	Operating Cost		Total Cost	
		Low	High	Low	High
Cold Production	Bitumen	5	8	12	16
Cold Heavy Oil Production with Sand	Bitumen	7	9	14	17
Cyclic Steam Stimulation	Bitumen	9	12	18	21
Steam Assisted Gravity Drainage	Bitumen	9	12	16	19
Mining/Extraction	Bitumen	8	11	16	18
Integrated Mining/Upgrading	Synthetic Crude	16	19	32	35

Source: National Energy Board - Canada, *Canada's Oil Sands Opportunities and Challenges to 2015: An Update*, June 2006

Many of the processes listed in Table 6-3 produce bitumen, and the North American bitumen market is immature and illiquid. There are no posted prices for bitumen, and marketers rely on different pricing formulas that relate the price of bitumen to posted crude oils such as Edmonton light, Lloydminster blend, and WTI. The price of bitumen has averaged 51% of the price of WTI crude in recent years [27].

Canadian bitumen is sent to refineries in several different forms. A major portion is upgraded to synthetic crude oil (SynCrude) and shipped to refineries that process light crude oils. Other forms of blended bitumen are sent to refineries capable of processing medium and heavy crude oils. In 2002, 57.6% of Canadian oil sands production was sent to refineries as synthetic crude oil and 42.4% was sent as blended bitumen [25].

Bitumen has a price disadvantage to synthetic crude oil that can be removed through upgrading, but there are costs associated with such upgrading. Table 6-3 gives 2005 cost estimates for a mining/extraction operation and an integrated mining/upgrading operation. The difference between these costs is an indication of the cost of upgrading bitumen to synthetic crude oil: an operating cost for upgrading of \$8 per barrel and a total cost for upgrading of \$16 per barrel.

Note: Data converted to US dollars from Canadian dollars at the rate of US\$1=C\$1.14253.

Illiquid markets have a small number of buyers and sellers with few trades.

Mixtures of SynCrude and bitumen (SynBit) and condensate, SynCrude and bitumen (DilSynBit) are sent to refineries that process medium weight crude oil. Bitumen in diluents (DilBit) is transported to refineries that process heavy oils.

While the economics of the Canadian oil sands industry are well understood, there are major differences between the Canadian experience and what may happen in the United States. These differences have to do with both the geology of the deposits and the processing technology. The major U.S. oil sands deposits, located in Utah, are more consolidated and less uniform than the Canadian deposits, and their smaller size precludes development of large operations. These factors in conjunction with mountainous terrain and variable geology will result in higher mining and in situ processing costs in Utah than those experienced in Canada. In addition, the Utah deposits are located in an arid environment, so obtaining sufficient water to operate either a hot water extraction process for the mined sands or an in situ steam injection process may be difficult. Hence, most current industrial focus is on using solvent extraction processes (see Section 4.2.2) for mined oil sands. Solvent extraction technology is in the research and development stage, many of the technical issues (e.g. the solvent used) are proprietary, and its economics are unknown. All these issues will result in Utah oil sands having incrementally higher production costs than the Canadian deposits.

6.1.3 Oil Shale

This section summarizes data on operating costs, capital costs, and the economics of production of oil shale resources. Oil shale has the least understood economics of the three resources examined. Technologies for oil shale production are still in the research and development phase and production data is not available. Published figures have ranged from \$10 - \$95 [28,29] per barrel. Part of the reason for this broad range is that although there is a long history of activity in the oil shale industry, there is not a large body of industrial knowledge based on successful operations from which to draw. The available cost estimates are generated either by companies involved in developing oil shale resources, with cost estimates based on engineering calculations rather than actual operating costs, or by analysts employed by various government agencies and think tanks. Actual operating costs will be determined through engineering pilot plants and small demonstration units. Once firmer numbers for operating costs are determined and technologies are proven, larger-scale commercial plants can be constructed. This process can take several years. The different technologies of mining followed by surface retorting and of in situ retorting have the possibility of drastically different economics [30].

Although oil shale production has been identified in 18 countries, most past production occurred in the mid- to late-1800s, with small operations serving local markets and economies [31]. With the advent of the worldwide petroleum industry, most oil shale operations became unprofitable and closed. Currently, oil shale is mined in Estonia, China and Brazil. Estonian production was 11.3 million tons in 2004. The majority of the Estonian production is burned in a thermoelectric power plant and not processed to recover the oil. In China, oil shale has been retorted at Fushun in Manchuria since the 1920s. Current production is about half a million barrels annually after peaking at 7.5 million barrels annually in the 1950s. In Brazil, the state-owned oil company Petrobras operates two retorts that produce about 3,800 BOPD for an annual production of 1.4 million barrels. Initial production in Brazil began in 1881 but was erratic until the Brazilian government purchased existing oil shale facilities in 1951 and placed them under Petrobras' control in 1954.

The longest oil shale producing areas were Scotland, with production from the 1860s to 1966, and Australia, with production from 1865 to 1955.

There have been numerous efforts in the past to develop oil shale resources in the United States. Initial production of shale oil began about 1850 and by 1860, there

were 50 to 60 plants in the United States and Canada distilling oil from shale or coal. The conventional petroleum industry quickly surpassed the oil shale industry due to superior economics. By the 1870s, all of the oil shale plants had either closed or been converted to the use of crude petroleum.

These plants were located in Oregon, Massachusetts, Connecticut, Ohio, Virginia, Kentucky, Missouri, Utah, New Brunswick, and Ontario.

There was an oil shale boom during the 1920s, when the rise of the automobile and diminished production from the Pennsylvania oil fields created concern about the future petroleum supply. There was another boom in oil shale activity from the 1940s through the 1960s as a result of the Synthetic Liquid Fuels Act, which was passed in 1944 to promote energy self-sufficiency for national security. The energy crises of the 1970s prompted another round of activity in the oil shale industry. In 1974, the federal government offered six lease sites on federal land for experimental development work, and bids for these tracts exceeded expectations. Winning bids for four leases, two each in Colorado and Utah, totaled \$450 million. In addition, over a dozen other operations achieved various states of development. There were also numerous proposals that never advanced past the planning stage. In 1982, the federal government established the Synthetic Fuels Corporation to offer loan guarantees. Although Congress dissolved the Synthetic Fuels Corporation two years after the 1984 collapse of crude oil prices, the expectation of financial assistance resulted in numerous design studies and proposals for oil shale development that would otherwise not have occurred. The last active oil shale facility from this era was the Union Oil operation located in Parachute, Colorado. This operation closed in 1991, and the site has been reclaimed [31].

No bids were received for two leases in Wyoming.

While mining and surface retorting of oil shale is technically feasible, its economic viability is questionable. Much of the current literature is conceptual in nature, and complete engineering and cost data continues to be developed by interested parties. As engineering pilot plants and field experiments are completed, more complete cost data will become available. The Alberta-Taciuk Processor (see Section 4.3.2) has been the focus of almost all research in surface retorting over the past 20 years. This type of reactor was operated at a demonstration level over a period of several years in Australia and produced over 1.3 million barrels of oil. Based on the experience of operating this reactor, a full-sized plant incorporating 13 Alberta-Taciuk reactors and producing 157,000 barrels per day of synthetic crude oil was projected to cost \$3.5-\$4.0 billion and have operating costs of \$7.50-\$8.00 per barrel [32].

The Rand Corporation estimated that a 50,000 BOPD mining and surface retorting plant would have capital costs of \$5-\$7 billion. This estimate was based on applying inflation factors to published costs for the Colony and Union projects of the 1970s and 1980s and other published design studies from the same era. Using similar methods, current operating expenses were estimated at \$17-\$23 per barrel. The Rand Corporation also estimated that WTI crude would have to be priced at \$70-\$95 per barrel for a first generation oil shale plant to be profitable. Advances in both mining and processing since the 1980s should serve to lower costs. Mining is now more efficient due to higher capacity equipment, while processing is much better controlled through advanced electronics and cheaper computer equipment [29].

The economics of in situ oil shale production are based largely on information released by Shell Oil relative to their In situ Conversion Process (ICP), as noted in Section 4.3.3. Shell has stated that their technology may be profitable at an oil price of \$30 per barrel. The energy required for ICP production equals 29% of the energy value

of the extracted product, with most of that energy being used to heat the source rock [29]. Current heater technology is electric and requires 250 - 300 KW-hrs per barrel. At \$0.05 per KW-hr, the cost of heating equates to \$12 - \$15 per barrel. A 100,000 BOPD operation would require approximately 1.2 GW of dedicated electric generating capacity; a 1 million BOPD operation would require ten times that amount. Sources for electrical generation include coal, natural gas, nuclear and wind power. Any of these heating methods are expected to be sensitive to the costs needed to comply with emissions and clean air standards.

A kilowatt hour (KW-hr) is a unit of electrical energy and is equal to one thousand watts of power supplied to, or taken from, an electrical circuit for one hour. One KW-hr is equal to 3,410 British Thermal Units.

The Department of Energy (DOE) report, Economic Impacts of U.S. Liquid Fuel Mitigation Options, projected that a plant producing 100,000 barrels per day of liquid fuels using the Shell ICP technology would have construction costs of \$8 billion and annual operating costs of \$500 million. The construction costs include an electrical power plant built specifically for the ICP operation, and the operating costs include the cost of electricity generation [33].

A gigawatt (GW) is one billion watts.

6.2 Infrastructure

Current heavy oil production in the United States is concentrated in southern California and the crude oil produced is refined in California. In contrast, the development of an oil sands and oil shale industry in the United States would necessitate many new upgrading and processing facilities, and these facilities would require integration with the existing petroleum infrastructure. Much of the synthetic crude oil produced by newly-constructed upgrading facilities would be sent to existing refineries for conversion to refined petroleum products. Given the location of major deposits, almost all oil sands and oil shale development in the United States will occur in the Rocky Mountain states. Although these states are current producers of petroleum and natural gas, much of the transportation and refining infrastructure is concentrated in the Gulf Coast region.

6.2.1 Refining Capacity

The nation's oil refineries have been running close to design capacity in recent years as a result of high demand for refined petroleum products and only incremental increases in refinery capacity. No new oil refineries have been constructed in the United States since the mid-1970s. The price of crude oil and petroleum products since the early 1980s have not remained at sufficiently high levels for a long enough time period to justify investing in a new refinery. Hence, all increases in refinery capacity since the 1970s have resulted from additions to existing refineries. Some analyses have indicated the possibility of over 1 million barrels a day of synthetic crude oil being produced from oil shale in Colorado and Utah [29,32,34]. Adding this quantity of crude oil to the market will require increased refining capacity, either as additions to existing refineries or as new refineries.

Current refinery capacity is concentrated along the Gulf Coast; only a small fraction of refinery capacity is located in the Rocky Mountains. Refinery data is reported geographically according to Petroleum Administration for Defense Districts (PADD), shown in Figure 6-4, which were established during World War II for allocating petroleum [35]. There are 149 oil refineries in the United States with a total operable capacity of 18.3 million barrels per stream day of atmospheric crude oil distillation as noted in Table 6-4 [36]. The Gulf Coast (PADD III) contains 47% of U.S. capacity. The West Coast (PADD V) and Rocky Mountains (PADD IV), the areas most directly impacted by

Atmospheric crude oil distillation is the process of separating crude oil components at atmospheric pressure by heating the crude oil to temperatures up to 660° F (350° C) and then condensing the fractions by cooling.

increased production from heavy oil, oil sands and oil shale, contain 18.2% and 3.5% of the nation's refining capacity, respectively. Detailed refinery capacity data by individual states can be found in Section 6.5 [36].

Figure 6-4. Petroleum Administration for Defense Districts.

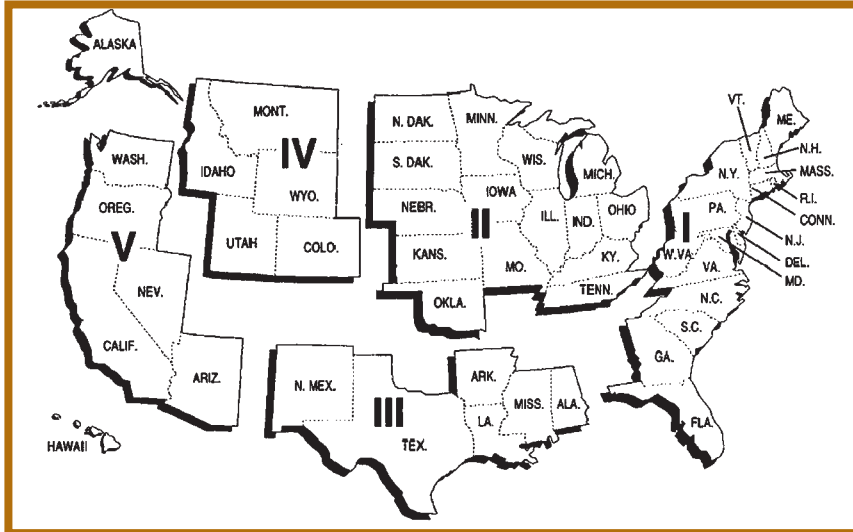

Source: Energy Information Administration, Petroleum Marketing Monthly 2007

Table 6-4. Refinery capacity by PADD district and process, barrels per stream day unless otherwise noted.

	Atmospheric Crude Oil Distillation		Vacuum Distillation	Thermal Cracking			
	Barrels per Calendar Day	Barrels per Stream Day		Delayed Coking	Fluid Coking	Visbreaking	Other/ Gas Oil
PADD I	1,713,100	1,806,500	709,100	46,000	53,000	0	0
PADD II	3,582,640	3,806,980	1,623,239	413,460	0	0	0
PADD III	8,274,086	8,720,722	4,185,975	1,311,200	42,000	0	10,600
PADD IV	595,550	636,800	237,050	38,450	10,400	0	0
PADD V	3,173,483	3,336,500	1,643,106	496,400	100,000	18,000	0
U.S. Total	17,338,814	18,307,502	8,398,470	2,035,510	205,400	18,000	10,600

	Catalytic Cracking		Catalytic Hydrocracking			Catalytic Reforming		Fuels Solvent Deasphalting			
	Fresh	Recycled	Distillate	Gas Oil	Residual	Low Pressure	High Pressure				
PADD I	739,700	7,000	13,550	0	16,000	22,300	22,000	0	189,200	133,900	22,000
PADD II	1,278,502	58,500	236,800	163,500	113,400	439,350	477,290	17,350			
PADD III	3,091,995	4,190	4,000	17,600	437,500	0	65,000	1,352,400	515,000	241,900	
PADD IV	196,206	87,240	246,200	296,900	200,400	41,700	88,280	9,040			
PADD V	881,480	516,600	920,200	286,000	335,950	2,308,650	1,550,420	386,290			
U.S. Total	6,187,883										

Source: Energy Information Administration, Refinery Capacity 2006

Calendar Day production takes into account maintenance time, environmental constraints and similar factors.

Stream Day refers to running at maximum capacity with no allowance for downtime or other factors.

While overall refinery capacity is a useful first measure, the bitumen produced from oil sands and the shale oil produced from surface retorting of oil shale require more intensive refining operations than light crude oil. The Rocky Mountain region (PADD IV) possesses very limited capacity for processing heavy oils similar to bitumen. The region contains 5.6% of the nationwide capacity for delayed coking and 5.0% of the capacity for fluid coking, but no refinery capacity exists for visbreaking or catalytic hydrocracking of heavy oils. Shale oil will require mild catalytic hydrotreatment to remove nitrogen and sulfur. Capacity for hydrotreating in PADD IV is 425,000 barrels per day out of a nationwide capacity of 14,808,000 BOPD, or 2.9% of nationwide capacity.

Heavy oil processing is designed to crack the large molecules into smaller molecules suitable for gasoline.

See Section 5 for detailed information on these upgrading technologies.

Petroleum refineries in the United States have been running near capacity for the past several years. The nationwide refinery utilization rate averaged 90.6% during 2005, while the refinery utilization rate in the Rocky Mountains (PADD IV) averaged 95.5%. During the middle of 2004, the utilization rate of Rocky Mountain refineries actually exceeded 100%, peaking at 101.9% in May, 2004 as seen in Figure 6-5 [37]. The refineries located on the West Coast, the center for heavy oil production in the United States, are also running at high capacity utilization rates, averaging 91.7% during 2005. Individual refinery capacity data for the states most likely to be affected by production of heavy oil, oil sands, and oil shale are included in Section 6-5.

Figure 6-5. PADD IV refinery utilization rates.

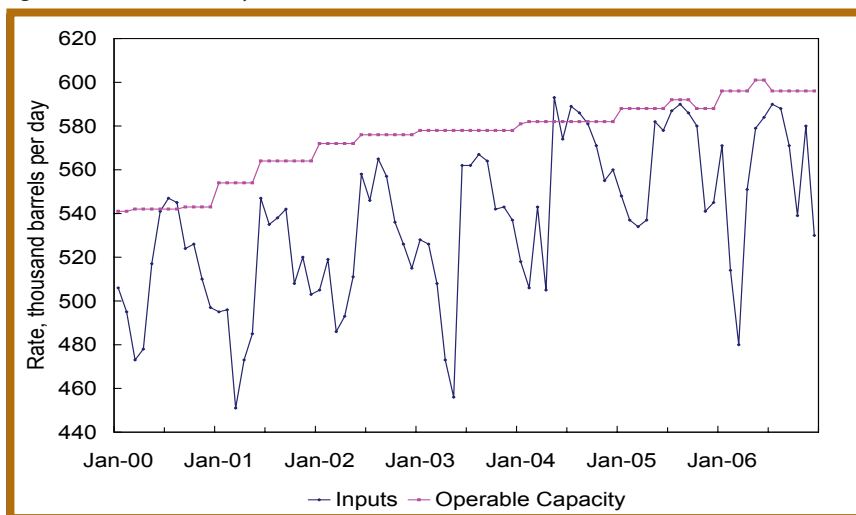

Source: Energy Information Administration, *Refinery Capacity and Utilization*, December 2006

6.2.2 Transportation

The United States has a well-developed and continually evolving infrastructure to transport crude oil from the wellhead to the refineries and finished product from the refineries to the final consumer. This infrastructure includes pipelines, tankers, barges, rail cars and tank trucks. The Rocky Mountain region relies primarily on pipelines and tank trucks to transport crude oil to the refineries and refined product to market. In fact, the Rocky Mountain region is more reliant on tank trucks for crude oil transportation than the country in general. In 2005, 9.24% of the crude oil delivered to refineries in the Rocky Mountain region was delivered by tank truck while the remaining 90.76% was delivered via pipeline. Nationwide, only 0.98% of the crude oil receipts at refineries arrived via tank truck during 2005 [36].

As seen in Table 6-5, the Rocky Mountain region is a net importer of crude oil with large quantities imported from Canada [38]. The Rocky Mountain region exports finished petroleum products to all surrounding areas with most of the exported product sent to the Gulf Coast (PADD III).

Table 6-5. Petroleum flows by pipeline (thousand barrels) between the Rocky Mountains and adjacent areas, 2005.

	Crude Oil	Petroleum Products	Total
Exports from the Rocky Mountains (PADD IV)			
To Midwest (PADD II)	41,646	21,007	62,653
To Gulf Coast (PADD III)	3,019	48,649	51,668
To West Coast (PADD V)	0	11,893	11,893
To Canada	405	1,008	1,413
Total	45,070	81,549	127,609
Imports to the Rocky Mountains (PADD IV)			
From Midwest (PADD II)	14,544	9,197	14,544
From Gulf Coast (PADD III)	0	13,359	13,359
From West Coast (PADD V) From	0	0	0
Canada	121,020	6,418	127,438
Total	135,564	28,974	155,341
Net Exports from the Rocky Mountains (PADD IV)			
To Midwest (PADD II)	27,102	11,810	48,109
To Gulf Coast (PADD III)	3,019	35,290	38,309
To West Coast (PADD V)	0	11,893	11,893
To Canada	(120,615)	(5,410)	(126,025)
Total	(90,494)	53,583	(27,714)

Source: Energy Information Administration, *Movements Between PAD Districts, December 2006*

In general, the pipeline system in the Rocky Mountain region serves to transport local production and imports from Canada to regional refineries and to refineries in the Midwest as illustrated in Figure 6-6 [39]. However, in recent years, increased crude oil imports from Canada into the Rocky Mountain region have strained the regional pipeline system's ability to deliver crude oil to refineries. Both the Enbridge and the Platte Pipelines (numbers 5 and 6 on Figure 6.6), which deliver crude oil from the Rocky Mountains to the Midwest, have been operating at full capacity since 2005 and are creating a bottleneck to oil exports from the Rocky Mountain region. This limited pipeline capacity, coupled with decreased local refinery demand during the first three months of 2006, led to Wyoming Sweet Crude being traded at a \$25 per barrel discount to WTI during March 2006 at the Guernsey market hub in Wyoming.

Figure 6-6. Crude oil pipelines and refineries, with capacities in barrels per day, in the Rocky Mountains and the Midwest.

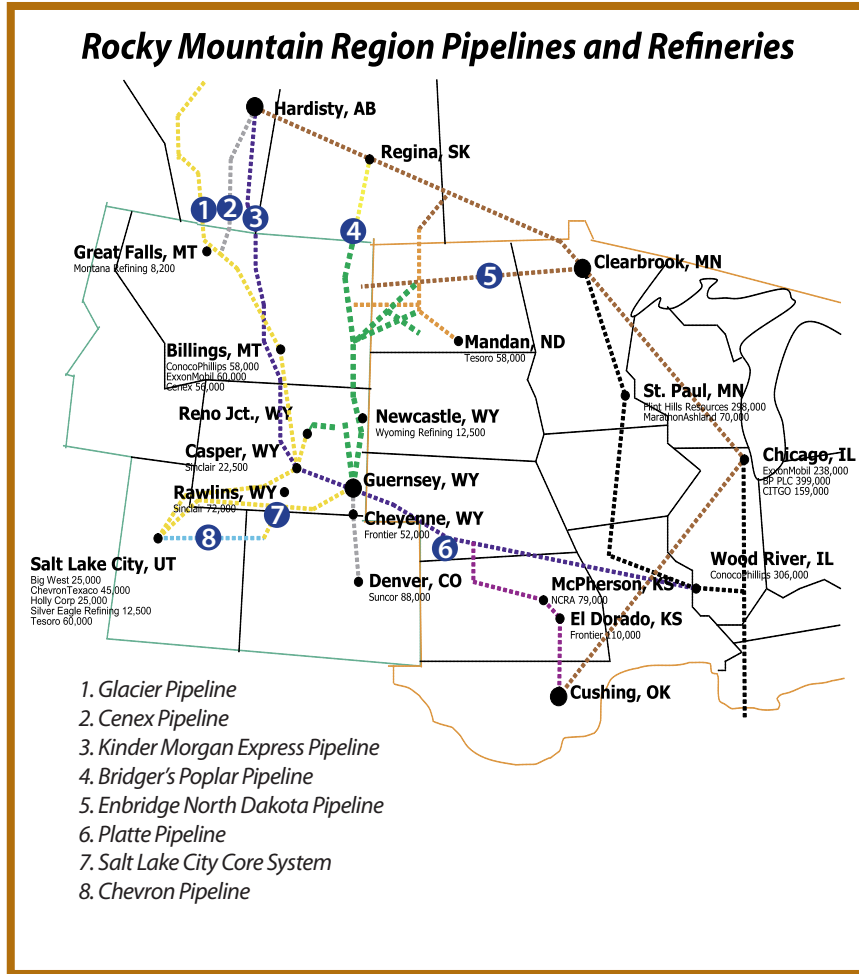

Source: Rocky Mountain Region Crude Oil Market Dynamics, Interstate Oil and Gas Compact Commission, 2007

Pipeline capacity in the Rocky Mountains is expected to increase. Nevertheless, it is unclear if proposed capacity increases will be sufficient as high oil prices are stimulating increased production in the Rocky Mountains and imports from Canada are expected to continue increasing [39].

The Piceance Basin in Colorado, with major deposits of oil shale, and the Uinta Basin in Utah, with major deposits of both oil sands and oil shale, are currently served by two ten-inch pipelines operated by Chevron Pipeline Company. These two pipelines start near Rangely, Colorado, and terminate at the Chevron Refinery in North Salt Lake (number 8 on Figure 6-6). The Salt Lake City Core System (number 7 on Figure 6-6), operated by Plains All American Pipeline LP, connects with the Chevron system at Rangely, Colorado and transports crude from the Western Corridor System to refineries in Utah. The Western Corridor System, which consists of the Glacier Pipeline (number 1 on Figure 6-6) and the Beartooth and Bighorn Pipelines, originates at the Canadian border near Cutbank, Montana and terminates near Guernsey,

Wyoming. In general, the Chevron Pipeline and connected systems transport crude oil from Montana, Wyoming, western Colorado and eastern Utah to the refineries in Utah. Connections to the Enbridge Pipeline (number 5 in figure 6.6) and the Platte Pipeline (number 6 in figure 6.6) transport crude oil from Canada and the Rocky Mountains to the Midwest.

In recent years, the Chevron Pipeline and connected systems have been running somewhat below capacity, although the operating companies are in the midst of expansion to accommodate an expected increase in crude oil imports from Canada. The Salt Lake City Core System has a combined throughput capacity of about 114,000 BOPD to Salt Lake City. Despite this capacity, the system only delivered 45,000 BOPD in 2006 due to constraints on connecting pipelines. A 95-mile (153 kilometer) expansion of the Salt Lake City Core System is currently being constructed and is expected to be completed in early 2008. When completed, the pipeline will have an estimated capacity of 120,000 BOPD [40].

Based on data from 15 pipelines constructed during 2005 and 2006, estimated construction costs averaged \$989,137 per mile (\$614,621 per kilometer) and actual construction costs averaged \$848,897 per mile (\$527,480 per kilometer). These data indicate that construction of any additional pipeline capacity will cost approximately \$1 million per mile (\$620,000 per kilometer), although there is a wide variation in pipeline costs depending on the size of the line and the terrain it passes through. Table 6-6 gives average pipeline costs obtained from permits filed with the Federal Energy Regulatory Commission (FERC) and the Canadian National Energy Board during the 12 months ending June 30, 2006 [41].

The Federal Energy Regulatory Commission regulates the interstate transmission of electricity, natural gas and oil; reviews proposals to construct liquefied natural gas terminals and natural gas pipelines; and licenses hydroelectric plants.

Table 6-6. Estimated construction costs of proposed pipeline projects, 2006.

Pipeline Diameter	Construction Cost, \$ per mile		
	Average	Low	High
12 inch	\$623,873	\$515,091	\$1,159,683
16 inch	884,118	601,274	948,857
20 inch	1,607,344	See Note	See Note
24 inch	1,551,586	1,248,916	4,883,022
30 inch	2,335,055	1,131,419	6,791,954
36 inch	3,568,308	1,900,376	8,066,470

Note: Only one project was proposed with a 20 inch diameter pipeline.

Source: C. E. Smith, *Special Report Pipeline Economics*, September 2006

Although pipelines currently exist in the Uinta and Piceance Basins, development of an oil sands and oil shale industry coupled with the current rise of conventional petroleum production in the area will undoubtedly require construction of additional pipeline capacity. The Sunnyside and Tar Sands Triangle oil sands deposits in eastern Utah are a significant distance from any existing pipeline. Exploiting these deposits may require new pipeline construction, although there is a rail line near the Sunnyside deposit and truck transportation is also an option. The situation for oil shale is similar. Given the distance from the Uinta and Piceance Basins to markets, the pipelines required to support a large oil shale industry may cost several hundred million dollars. Which of the three transportation options are utilized will depend on the size of any oil sand or oil shale industry and the resulting economics.

Interstate crude oil and petroleum product pipelines in the United States are regulated as common carriers by FERC. The current rate for transporting crude oil from Rangely, Colorado to the refineries in Utah via the Chevron Pipeline is 63.31¢ per barrel with an additional 16.56¢ per barrel for loading or unloading tank trucks [42]. The rate for transporting crude oil via tank truck is noticeably more expensive and is dependent upon the distance, with shorter distances having a higher cost per barrel. The present rate for trucking crude oil from East Ouray, south of Vernal, Utah, to the refineries in Salt Lake City is \$4.772 per barrel with a minimum load of 265 barrels.

Both the availability of refinery capacity and the location of markets for the final product are important aspects in determining the transportation method and route used for production from oil sands and oil shale. Given that refineries in the Rocky Mountains (PADD IV) have the highest capacity utilization in the country, synthetic crude oil produced from oil sands and oil shale will need to be shipped to other regions of the country for refining.

6.3 Socioeconomics

Additional heavy oil production is much less likely to result in social and economic impacts for the producing areas. These areas already have significant oil production, although production has been declining since the 1980s. Any increase in heavy oil production would offset this decline and maintain the petroleum industry in these areas.

Increased development of oil sands and oil shale has a strong possibility of altering the economies of the areas where these resources are located. In Colorado and Utah, future growth in production from oil sands and oil shale has the potential to increase in-migration to the area, with resulting population and workforce growth. While additional jobs and economic growth are desirable, there are associated social costs that arise. Rapid in-migration tends to strain local resources and infrastructure such as housing, schools, utilities, sanitation and roads. Some of these impacts can be mitigated through the planning and permitting process, but development of a large-scale oil sands and/or oil shale industry will alter the economic and social structure of nearby communities.

The states most likely to experience rising production of these resources are all current producers of crude oil and natural gas. Jobs in these industries pay significantly better than the average job as listed in Table 6-7 [43], and these pay differentials can be expected to continue with rising production.

Table 6-7. Annual average wages in the affected states by industry, 2005.

	All Industries	Oil and Gas Extraction (NAICS 211)	Drilling Oil and Gas Wells (NAICS 213111)	Support Activities for Oil and Gas Operations (NAICS 213112)
Alaska	\$40,216	\$145,393	\$81,402	\$79,705
California	46,211	144,265	64,783	57,572
Colorado	41,601	131,913	58,975	71,055
Utah	33,328	72,986	57,696	49,529

Source: Bureau of Labor Statistics, *Quarterly Census of Employment and Wages*, November 2006

Since socioeconomic impacts affect regional economies, it is necessary to examine the areas most likely to be affected by increased development of heavy oil, oil sands, and oil shale resources.

6.3.1 Heavy Oil

Three separate areas are examined in connection with heavy oil production in the United States. These are Kern County, California; an area in southern California defined by the contiguous counties of Los Angeles County, Orange County, and Ventura County; and the North Slope Borough of Alaska.

Past heavy oil production in the United States has centered in southern California, with Kern County responsible for the majority of the production. Kern County produced 176 million barrels of crude oil in 2005 or 9.3% of nationwide production. The largest oil field in Kern County is the Midway-Sunset Field, which despite continuous production for over 110 years, produced 42 million barrels in 2005. Three of the five largest oil fields in the country are located in Kern County.

The southern California counties are also major oil producers. Los Angeles County produced more crude oil in 2005 than 22 of the 31 oil-producing U.S. states and two federal off-shore areas. Orange and Ventura Counties are also large oil producers, ranked fifth and third respectively among California counties for 2005 production. The Wilmington Oil Field, by some measures the largest heavy oil field in the country [44], lies in southeastern Los Angeles County near the Los Angeles-Orange County line. In 2005, the combined production of Kern County and the three southern California counties accounted for 95% of the crude oil produced in California and 11.4% of nationwide crude oil production.

Although the North Slope of Alaska is not traditionally a large heavy oil producer, estimates for heavy oil in place range from 25 to 30 billion barrels (see Section 3.1). North Slope oil production has dropped by more than half since peaking in 1988, and heavy oil production may become more prominent should the reservoirs containing lighter oil continue to be depleted and worldwide demand remain high.

Geographically, Kern County lies in the southern Central Valley of California. It had an estimated population of 756,981 in 2006. In the map of Kern County shown in Figure 6-7, the blue-shaded areas are urban. Only 2.4% of Kern County's area,

Industry specific economic data is released according to the North American Industry Classification System (NAICS) Codes. The NAICS Codes contain 10 major industrial sectors and these sectors are further subdivided as necessary to classify various industries. The oil industry is included in NAICS Codes 211 – Oil and Gas Extraction, 213111 – Drilling Oil and Gas Wells, and 213112 – Support Activities for Oil and Gas Operations. Other NAICS codes of interest to the petroleum industry are NAICS 32411 – Petroleum Refineries, NAICS 4861 – Pipeline Transportation of Crude Oil, and NAICS 486910 – Pipeline Transportation of Refined Petroleum Products.

Los Angeles and Orange Counties combined comprise the Los Angeles-Long Beach-Santa Ana Metropolitan Area while Ventura County defines the Oxnard-Thousand Oaks-Ventura Metropolitan Area.

encompassing the Bakersfield Metropolitan Area, is considered urban. However, this urban area contains 88% of the county's population.

The oil fields in Kern County are located primarily in the western part of the county, with the easternmost fields on the eastern edge of Bakersfield. The Fruitvale, Kern Bluff, Stockdale and Union Avenue Fields are located within the Bakersfield city limits. The Midway-Sunset Field runs from northwest to southeast on the western edge of the county. The city of Taft is in the center of the Midway-Sunset Field and the city of Maricopa is near the southern end of the field. There are also numerous fields that lie in the agricultural area between Bakersfield and the mountainous eastern edge of the county.

Figure 6-7. Kern County, California. Blue shading indicates urban areas.

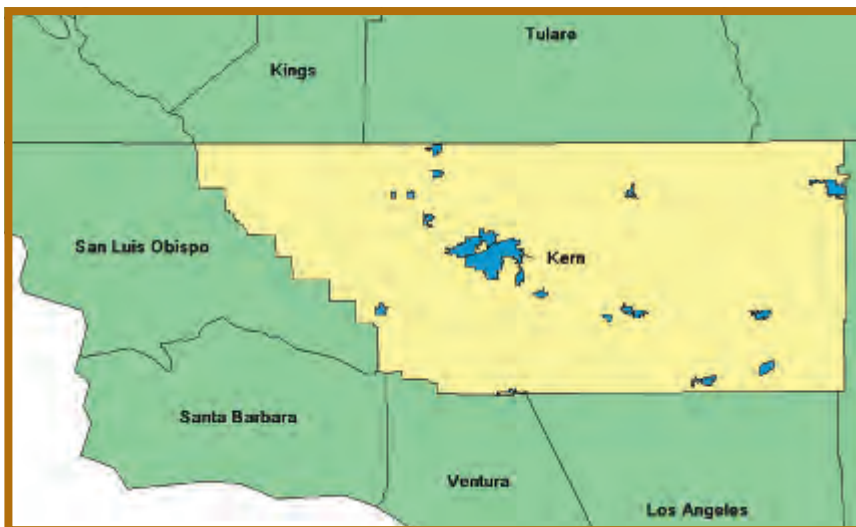

Source: Utah Heavy Oil Program

The southern California area examined, shown in Figure 6-8, is heavily populated; Los Angeles County alone contains 88 incorporated cities. The San Gabriel Mountains separate the desert valleys from the populated coastal areas of Los Angeles County. Orange County, south of Los Angeles County, is the fifth most populous county in the country and contains 34 incorporated cities. Geographically, the county can be divided into the coastal plain in the northern part of the county and the Santa Ana Mountains in the south. Ventura County lies northwest Los Angeles County on the Pacific Coast and is most heavily populated in the southern portion of the county. These three counties had a combined estimated population of 13,701,187 in 2006. Of the 6,695 square miles (17,340 square kilometers) in the three counties, 31% of the land area or 2,072 square miles (5,366 square kilometers) is considered urban, but this 31% contains 99.3% of the population.

The oil fields in southern California generally run northwest to southeast, parallel to the Pacific Ocean coast. Several fields, notably the Huntington Beach, Torrance, and Wilmington Fields, are located both on the coastal plain and offshore. Other fields are farther inland, east of the coastal range. The unique feature of the southern California oil fields is that they coincide with some of the most densely populated areas in the country. By contrast, most other oil and gas production in the country occurs in rural areas.

The Bureau of the Census defines urban areas as census blocks that have a population density of at least 1,000 persons per square mile and surrounding census blocks with a population density of 500 persons per square mile. Adjacent census blocks with a lower population density are also included if they meet criteria established by the Bureau of the Census.

The Office of Management and Budget defines Metropolitan Areas as counties with populations of at least 50,000 and adjacent counties that show a strong economic linkage to the core county through commuting.

Figure 6-8. Southern California area. Blue shading indicates urban areas.



Source: Utah Heavy Oil Program

In contrast to the two California areas, the North Slope Borough of Alaska is a large, sparsely populated area. The Bureau of the Census estimated the borough's 2006 population at 6,790. The only urban area in the North Slope Borough is Barrow, where 11.25 square miles (29.14 square kilometers) are of sufficient population density to be considered urban. This 0.1% of the total area (88,817 square miles or 23,000 square kilometers) contains 59% of the borough's population.

The socioeconomic characteristics of the three heavy oil areas vary as seen in Table 6-8 [43,45-48]. In 2005, the North Slope Borough of Alaska had the highest average wage of \$69,494 due to the heavy concentration of employment in the petroleum industry. In contrast, the average annual wage was \$46,369 in Southern California and \$34,165 in Kern County. Per capita personal income in the three areas ranged from a low of \$24,999 in Kern County to a high of \$42,209 in the North Slope Borough.

The North Slope Borough has the highest unemployment rate of the three areas examined due to concentration of employment in one industry and few other job opportunities.

Table 6-8. Socioeconomic profiles of examined heavy oil areas.

	Kern County, California	North Slope Borough, Alaska	Southern California
Population (2006)	756,981	6,790	13,730,187
Population (2000)	661,645	7,373	13,118,824
Percent Urban	88.2	58.5	99.3
Percent Rural	11.8	41.5	0.7
Area, square miles (2000)	8,141	88,817	6,695
Percent Urban	2.4	Less than 0.1	31.0
Percent Rural	97.6	Greater than 99.9	69.0
Total Wages Paid, (2005)	\$9,090,278,000	\$628,270,000	\$273,542,156,000
Average Annual Wage (2005)	\$34,165	\$69,494	\$46,486
Total Personal Income (2005)	\$18,924,066	\$286,597,000	\$507,402,331,000
Per Capita Personal Income (2005)	\$24,999	\$42,209	\$36,955
Labor Force (2005)	328,850	3,645	6,844,671
Employment (2005)	301,611	3,295	6,507,818
Unemployment Rate, percent (2005)	8.3	9.6	4.9

The wage data is by place of employment while the income data is by place of residence, so any wages paid to oil workers on the Alaska North Slope who maintain full-time residences elsewhere are not included in the personal income data.

Source: Bureau of Labor Statistics, *Quarterly Census of Employment and Wages*, November 2006; Bureau of Labor Statistics, *Local Area Unemployment Statistics*, November 2006; Bureau of the Census, *Population Estimates*, May 2007; Bureau of the Census, *American FactFinder 2000 Decennial Census Data*, November 2006; Bureau of Economic Analysis, *Local Area Personal Income*, May 2007

The data in Table 6-9 shows that the petroleum industry pays higher than average wages in the three areas examined [43]. Kern County employment in the petroleum industry was 7,479 persons in 2005. Total oil industry employment in the other two heavy oil areas is difficult to determine due to data disclosure issues. The average annual wage in 2005 for persons working in the Oil and Gas Extraction industry (NAICS 211) was \$150,483 in southern California and \$90,200 in Kern County, over three times the average annual wage for these areas.

Table 6-9. Oil industry employment and wages in the heavy oil areas, 2005.

	Kern County, California	North Slope Borough, Alaska	Southern California
Total Employment			
NAICS 211 - Oil and Gas Extraction	2,823	ND	2,371
NAICS 213111 - Drilling Oil and Gas Wells	1,170	ND	ND
NAICS 213113 - Support Activities for Oil and Gas	3,486	3,228	1,302
Total Wages			
NAICS 211 - Oil and Gas Extraction	\$254,605,000	ND	\$356,795,000
NAICS 213111 - Drilling Oil and Gas Wells	\$71,876,000	ND	ND
NAICS 213113 - Support Activities for Oil and Gas	\$191,768,000	\$241,952,000	\$ 84,544,000
Average Annual Wage			
NAICS 211 - Oil and Gas Extraction	\$90,200	ND	\$150,483
NAICS 213111 - Drilling Oil and Gas Wells	\$61,421	ND	ND
NAICS 213113 - Support Activities for Oil and Gas	\$55,004	\$74,962	\$64,934

Source: Bureau of Labor Statistics, Quarterly Census of Employment and Wages, November 2006

Table 6-10. Employment by industry in Kern County, California, 2005.

	Employment	Distribution, percent	Location Quotient
Natural Resources and Mining	53,487	20.1	15.3
Agriculture, Forestry, Fishing and Hunting	45,030	16.9	19.1
Mining	8,457	3.2	7.5
Construction	18,609	7.0	1.3
Manufacturing	12,278	4.6	0.4
Trade, Transportation and Utilities	43,020	16.2	0.8
Information	2,516	0.9	0.4
Financial Activities	8,697	3.3	0.5
Professional and Business Services	23,375	8.8	0.7
Education and Health Services	21,640	8.1	0.6
Leisure and Hospitality	20,004	7.5	0.8
Other	8,768	3.3	1.0
Government	54,189	20.4	1.3
Total	266,068	100.0	1.0

Source: Bureau of Labor Statistics, Quarterly Census of Employment and Wages, November 2006

Examining the distribution of employment by industry for the three heavy oil areas reveals some interesting patterns. Employment in Kern County, California, is highly concentrated in the Natural Resources and Mining industry compared to the country

Under the North American Industry Classification System (NAICS) Codes, the Mining Industry includes Oil and Gas Extraction in addition to solid mineral mining and support activities for mining. Because of data disclosure issues, county-level data for individual industries is often suppressed for rural areas to avoid revealing individual company data.

ND: Not Disclosable to avoid disclosing individual company data.

Note: Southern California is defined as Los Angeles, Orange, and Ventura Counties.

Location Quotients are calculated by dividing the percentage of employment due to a given industry for the area in question by the percentage of employment due to that industry in a reference area, in this case the country as a whole. A location quotient of two indicates the residents of the area in question are twice as dependent on the subject industry as the country as a whole.

The employment by industry data is gathered on a place of employment basis rather than on a place of residence basis, so total employment does not equal that presented in the socioeconomic profiles for the various regions.

as a whole as seen in Table 6-10 [43]. Mining accounts for 3.2% of total employment, which is 7.5 times the concentration of nationwide employment in this industry. Employment in the industrial sectors directly related to the petroleum industry was 7,479 in 2005, or 88% of total mining employment in Kern County.

The North Slope Borough of Alaska is extremely dependent on the Oil and Gas industry for employment as seen in Table 6-11 [43]. Employment in the Mining industry, which in this area is completely comprised of the oil and gas industry, was 5,190 in 2005, or over half of all employment in the borough. The location quotient for mining employment is 134.8, indicating that the borough is over 130 times as dependent on the petroleum industry for employment as the nationwide average.

Table 6-11. Employment by industry of North Slope Borough, Alaska, 2005.

	Employment	Distribution, percent	Location Quotient
Natural Resources and Mining	5,190	57.4	43.8
Agriculture, Forestry, Fishing and Hunting	0	0.0	0.0
Mining	5,190	57.4	134.8
Construction	ND	ND	ND
Manufacturing	ND	ND	ND
Trade, Transportation and Utilities	384	4.2	0.2
Information	50	0.6	0.2
Financial Activities	174	1.9	0.3
Professional and Business Services	757	8.4	0.7
Education and Health Services	136	1.5	0.1
Leisure and Hospitality	469	5.2	0.5
Other	195	2.2	0.7
Government	1,553	17.2	1.1
Total	9,041	100.0	1.0

Source: Bureau of Labor Statistics, *Quarterly Census of Employment and Wages*, November 2006

In 2005, total employment in the borough was 9,041 jobs (Table 6-11), but the total number of employed borough residents was only 3,295 (Table 6-8). Thus, an estimated 5,746 persons are employed in the North Slope Borough and maintain full-time residence elsewhere. This rotating workforce of 5,746 is equal to 88% of the borough's permanent population. Although Prudhoe Bay is the center of oil production in the North Slope Borough, the 2000 Decennial Census revealed a permanent population of only five persons.

The southern California area examined, although an important component of the country's oil economy with almost 2.1% of domestic production in 2005, has a much more diversified economy than either Kern County, California or North Slope Borough, Alaska. Of a total employment of nearly six million during 2005, only 5,132 jobs (0.1% of total employment) were in the Mining industry as seen in Table 6-12 [43]; an estimated 80% of the Mining jobs were in the Oil and Gas industry. All of the location quotients for southern California are between 0.5 and 1.8, indicating that the area's economy is similar to the national economy. This large, diversified economy is a good indicator that increased oil production will not result in large social and economic impacts on the area's economy.

Table 6-12. Employment by industry of the three southern California counties, 2005.

	Employment	Distribution, percent	Location Quotient
Natural Resources and Mining	40,024	0.7	0.5
Agriculture, Forestry, Fishing and Hunting	34,893	0.6	0.7
Mining	5,132	0.1	0.2
Construction	268,343	4.6	0.8
Manufacturing	687,646	11.7	1.1
Trade, Transportation and Utilities	1,116,431	19.0	1.0
Information	245,167	4.2	1.8
Financial Activities	407,015	6.9	1.1
Professional and Business Services	882,731	15.0	1.2
Education and Health Services	613,839	10.4	0.8
Leisure and Hospitality	571,888	9.7	1.0
Other	291,909	5.0	1.5
Government	756,505	12.9	0.8
Total	5,884,440	100.0	1.0

Source: Bureau of Labor Statistics, *Quarterly Census of Employment and Wages*, November 2006

The three areas examined for heavy oil production are currently significant producers of crude oil and natural gas as seen in Table 6-13 [12-17,49]. Their collective production of 524 million barrels of crude oil during 2005 was just under 28% of total domestic production. Consistent with most other areas of the country, crude oil production in all three areas has been declining in recent years. Increased heavy oil production will mainly counteract this decline in lighter crude oil production and will not result in a large increase in employment in the petroleum industry in these areas. On the natural gas side, the North Slope Borough of Alaska produces over 3 trillion cubic feet (85 million cubic meters) of natural gas annually, but there is no existing pipeline to transport the gas to market. Other than a small amount that is used locally, the gas is re-injected in the geological formations to maintain pressure and production of crude oil. As with heavy oil production, natural gas production has been declining recently in all three areas, so any increases in heavy oil production will counteract this decline.

Table 6-13. Recent oil and gas production in heavy oil areas.

Year	Kern County, California	North Slope Borough, Alaska	Total Southern California	Component Counties of Southern California		
				Los Angeles County, California	Orange County, California	Ventura County, California
Crude Oil (thousand barrels)						
2005	176,637	308,159	39,083	26,996	5,082	7,004
2004	185,160	324,218	40,434	27,151	5,358	7,925
2003	191,561	345,527	41,262	27,233	5,758	8,271
2002	198,774	348,098	42,143	27,609	6,026	8,509
2001	200,813	343,431	42,791	28,105	6,063	8,624
Natural Gas (million cubic feet)						
2005	179,641	3,451,417	22,528	13,379	2,642	6,507
2004	184,708	3,454,559	23,662	13,008	3,191	7,462
2003	193,016	3,389,711	22,739	12,186	2,927	7,626
2002	209,395	3,290,999	23,213	11,961	2,862	8,390
2001	221,732	3,215,301	24,611	12,729	2,839	9,043

Note: May not total exactly due to rounding.

Source: Alaska Department of Natural Resources, *Alaska Oil and Gas Report, May 2006*; California Department of Conservation, *Annual Reports of the State Oil and Gas Supervisor, Years 2001-2005*

The population of each of the three heavy oil areas is projected to increase over the next several decades, although the amount and rate of change varies greatly. Kern County, California is projected to have a population of over 1.5 million in 2050, more than double the 2005 estimate. By contrast, the 2005 projected population for the three southern California counties is 16.2 million, up 18 percent from the 2005 estimate.

The North Slope Borough is projected to have a 2018 population of 12,211, an increase of 76 percent over the 2005 estimate. These population projections do not account for any population increase due to increased heavy oil production. However, increased heavy oil production should not significantly affect the population or economy of these areas. Oil production in each area has been declining since the 1980s and additional production of heavy oil will mostly counteract the decline in production of lighter crude oil. Additionally, the southern California area is densely populated with a very diversified economy.

The population of each of the three heavy oil areas is projected to increase over the next several decades, although the amount and rate of change varies greatly. Kern County is projected to have a population of over 1.5 million in 2050, more than double the 2005 estimate [50]. By contrast, the 2050 projected population for the three southern California counties is 16.2 million, up 18% from the 2005 estimate [50]. The North Slope Borough is projected to have a 2018 population of 12,211, up 76% from the 2005 estimate [51]. These population projections do not account for any population increase due to increased heavy oil production. Nevertheless, as noted above, increased heavy oil production should not significantly affect the population or economy of these areas.

6.3.2 Oil Sands

The most likely oil sands production in the United States is focused on the seven-county area in eastern and central Utah shown in Figure 6-9. These counties contain the Asphalt Ridge, P.R. Spring, Sunnyside, Tar Sands Triangle and Circle Cliffs deposits. The areas in Figure 6-9 with blue shading represent urban areas.

Figure 6-9. Utah counties directly impacted by future oil sands development. Blue shading indicates urban areas.

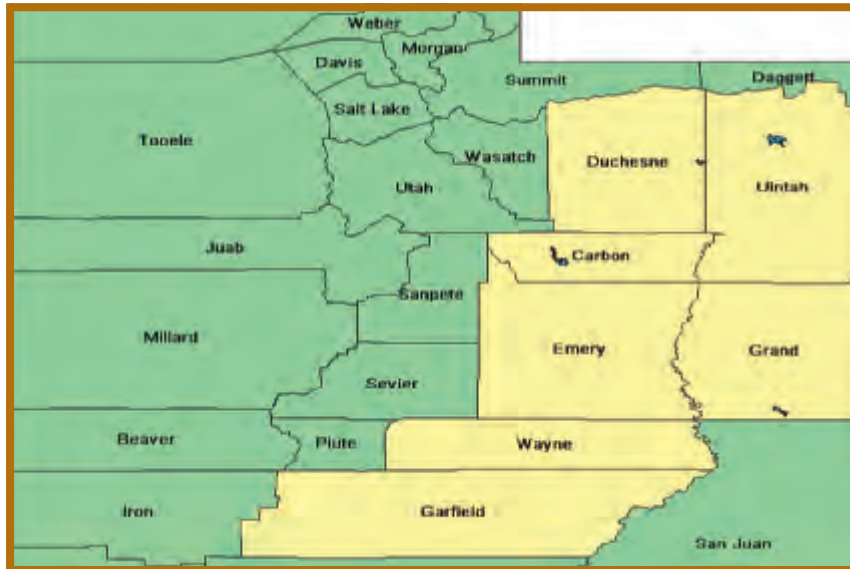

Source: Utah Heavy Oil Program

Although these counties are contiguous, they are separated by mountain ranges, and the local economics vary widely. On the north, the area is bounded by the Uinta Mountains, with most of the populated area of Duchesne and Uintah Counties lying in the Uinta Basin. The conventional oil and gas industry is a major contributor to the economy of these two counties. Of 8,232 active oil and gas wells in Utah, 5,723 are located in Duchesne and Uintah Counties. The Uinta Basin is bounded on the south by the Book Cliffs, which separate Duchesne and Uintah Counties from the area to the south. Coal mining and electric power generation are the economic drivers for Carbon and Emery Counties. Twelve of the 13 coal mines in Utah are located in Carbon and Emery Counties, and three coal-fired power plants in the two counties have a total capacity of 2,389 MW. Although there is some oil and gas extraction in both Grand and Garfield Counties, these two counties along with Wayne County are economically dependent on tourism. Several national parks and monuments are located in these three counties, including Arches National Park, Bryce Canyon National Park, Capital Reef National Park, Grand Staircase Escalante National Monument, Canyonlands National Park, and Glen Canyon National Recreation Area.

A megawatt (MW) is one million watts.

The combined population of these seven counties was estimated at 88,311 in 2006, as listed in Table 6-10 [43,45-48]. The population is projected to be 122,627 in 2050, a 39% increase. The four areas in these counties of sufficient population density to be considered urban are Roosevelt in Duchesne County, Vernal in Uintah County, Price in Carbon County and Moab in Grand County. These four urban areas account for only 0.1% of the land area but 40.1% of the population. The average population

density of the seven-county area was 1.4 persons per square mile (0.54 persons per square kilometer) in 2000, compared to 27.2 persons per square mile (10.5 persons per square kilometer) for the state of Utah.

Table 6-14. Socioeconomics of the oil sands area.

	Oil Sands Area
Population (2006)	88,311
Population (2000)	86,633
Percent Urban	40.1
Percent Rural	59.9
Area, square miles (2000)	24,961
Percent Urban	0.1
Percent Rural	99.9
Total Wages Paid (2005)	\$1,153,729,000
Average Annual Wage (2005)	\$30,787
Total Personal Income (2005)	\$2,162,376,000
Per Capita Personal Income (2005)	\$24,486
Labor Force (2005)	48,812
Employment (2005)	46,469
Unemployment Rate, percent (2005)	4.8

Source: Bureau of Labor Statistics, *Quarterly Census of Employment and Wages, November 2006*; Bureau of Labor Statistics, *Local Area Unemployment Statistics, November 2006*; Bureau of the Census, *Population Estimates, May 2007*; Bureau of the Census, *American FactFinder 2000 Decennial Census Data, November 2006*; Bureau of Economic Analysis, *Local Area Personal Income, May 2007*

Table 6-15. Employment by industry in the oil sands area, 2005.

	Employment	Distribution, percent	Location Quotient
Natural Resources and Mining	5,085	13.6	10.4
Agriculture, Forestry, Fishing and Hunting	ND	ND	ND
Mining	ND	ND	ND
Construction	2,099	5.6	1.0
Manufacturing	826	2.2	0.2
Trade, Transportation and Utilities	8,104	21.6	1.1
Information	ND	ND	ND
Financial Activities	ND	ND	ND
Professional and Business Services	ND	ND	ND
Education and Health Services	3,102	8.3	0.7
Leisure and Hospitality	4,770	12.7	1.3
Other	1,026	2.7	0.8
Government	8,642	23.1	1.4
Total	37,475	100.0	1.0

Source: Bureau of Labor Statistics, *Quarterly Census of Employment and Wages, November 2006*

The oil sands area has a high concentration of employment in the Natural Resources and Mining industry, with 13.6% of total employment as seen in Table 6-15 [43].

While oil and gas extraction dominate in the Uinta Basin counties of Duchesne and Uintah, Carbon and Emery counties have significant coal mining employment [52].

Of the seven counties in the oil sands area, all but Wayne County are current producers of either crude oil or natural gas as noted in Table 6-16 [53]. Production of both crude oil and natural gas have increased in recent years as high prices have stimulated exploration and drilling. Duchesne and Uintah Counties dominate in oil production, accounting for 96% of the area's production in 2005. The minor amounts of crude oil produced from Carbon and Emery Counties are incidental to coalbed methane recovery. Oil production in Garfield County occurs at minor but consistent levels, while natural gas dominates in Grand County. There is no hydrocarbon production in Wayne County.

Table 6-16. Recent oil and gas production in the oil sands area.

Year	Total Oil Sands Area	Component Counties of the Oil Sands Area						
		Carbon County, Utah	Duchesne County, Utah	Emery County, Utah	Garfield County, Utah	Grand County, Utah	Uintah County, Utah	Wayne County, Utah
Crude Oil (thousand barrels)								
2005	11,450	9	6,670	3	198	198	4,371	0
2004	10,002	5	5,838	5	201	234	3,720	0
2003	7,721	2	4,341	6	203	99	3,069	0
2002	7,642	0	4,291	2	210	121	3,016	0
2001	8,506	0	4,980	5	206	120	3,195	0
Natural Gas (million cubic feet)								
2005	281,940	74,823	20,090	16,607	9	6,581	163,831	0
2004	251,010	79,239	14,641	17,443	8	7,225	132,455	0
2003	231,219	85,180	11,955	17,213	6	5,624	111,241	0
2002	227,009	90,701	12,476	13,901	6	5,538	104,386	0
2001	207,704	86,533	13,934	7,719	9	5,601	93,909	0

Source: Utah Department of Natural Resources, Oil and Gas Program Production Reports, October 2006

The amount of in-migration to a Utah oil sands industry will not compare to the scope and scale of that associated with the Alberta experience for two reasons. First, the nature of the Utah oil sands deposits precludes the type of large-scale development that has occurred in Canada. The Canadian oil sands are primarily large, unconsolidated deposits that occur in level terrain. By contrast, the deposits in Utah are smaller and often consolidated with high-grade deposits interspersed with lower-grade oil sands or shale. Additionally, many of the Utah deposits are in steep, mountainous terrain. Therefore, development of an oil sands industry in Utah will result in smaller operations that may be less efficient for lack of economy of scale. Second, many of the oil sands deposits in Utah are co-located with conventional oil and gas operations or with coal mines. The Asphalt Ridge deposit is near Vernal, Utah, the commercial center of the Uinta Basin and the center for oil and gas operations in the area. The Sunnyside deposit is near several operating coal mines. The current rise in employment in the area due to rising oil, gas and coal prices suggests that development of Utah's oil sand

resources will not cause significant social and economic impacts on the area above those currently occurring. In terms of local impact, development of an oil sands mining and extraction operation would be similar to opening an additional coal mine. Similarly, installing an in situ operation aimed at recovering bitumen from oil sands would have impacts similar to drilling an equal number of conventional oil and gas wells.

6.3.3 Oil Shale

Development of an oil shale industry in the United States has the highest likelihood of significant social and economic impacts on the surrounding region. A five-county area in northeastern Utah and northwestern Colorado, shown in Figure 6-10, is the most likely site of future oil shale development in the United States. The blue areas in Figure 6-10 represent urban areas. Although there are also significant oil shale deposits in Wyoming, most past and current interest has focused on these five counties.

Figure 6-10. Counties directly impacted by future oil shale development. Blue shading indicates urban areas.

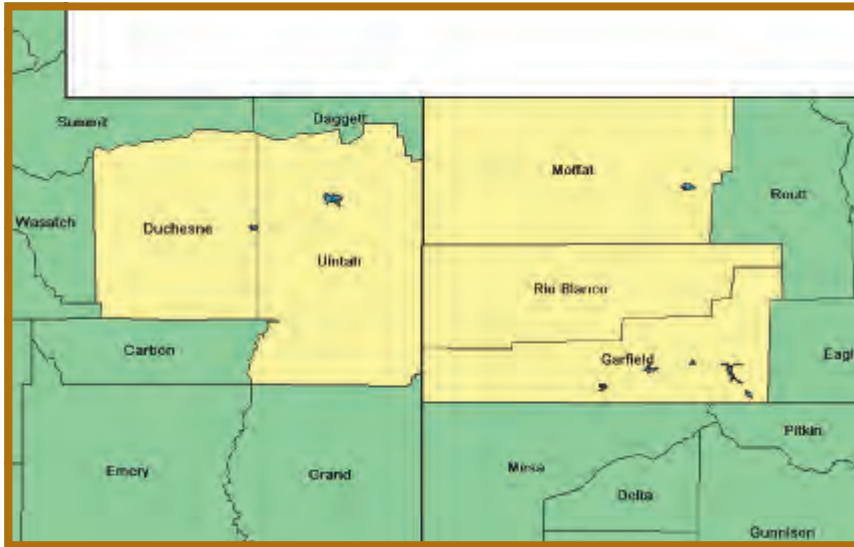

Source: Utah Heavy Oil Program

This area overlaps the oil sands area in both Duchesne and Uintah Counties, Utah. The Uinta Basin occupies most of Duchesne and Uintah Counties, Utah, which are bordered on the north by the Uinta Mountains and on the south by the Book Cliffs. Moffat and Rio Blanco Counties, Colorado, are mostly comprised of high deserts and hills and are drained by the Yampa and White Rivers. The Book Cliffs traverse Garfield County, Colorado.

The total population of the five-county area was estimated at 111,626 in 2006 as noted in Table 6-17 [43,45-48]. Although only 0.2% of the 18,625 square miles (48,328 square kilometers) in the area is considered urban, the urban areas, contain 54.4% of the population. The average annual wage in the area was \$34,292 during 2005 while the per capita personal income was \$28,618.

Table 6-17. Socioeconomics of the oil shale area.

	Oil Shale Area
Population (2006)	111,626
Population (2000)	102,556
Percent Urban	54.4
Percent Rural	45.6
Area, square miles (2000)	18,625
Percent Urban	0.2
Percent Rural	99.8
Total Wages Paid, (2005)	\$1,666,956,000
Average Annual Wage (2005)	\$34,292
Total Personal Income (2005)	\$3,194,470,000
Per Capita Personal Income (2005)	\$28,618
Labor Force (2005)	64,591
Employment (2005)	62,034
Unemployment Rate, percent (2005)	4.0

Source: Bureau of Labor Statistics, *Quarterly Census of Employment and Wages*, November 2006; Bureau of Labor Statistics, *Local Area Unemployment Statistics*, November 2006; Bureau of the Census, *Population Estimates*, May 2007; Bureau of the Census, *American FactFinder 2000 Decennial Census Data*, November 2006; Bureau of Economic Analysis, *Local Area Personal Income*, May 2007

The five-county oil shale area is 29.1 times as dependent on mining for employment as the country as a whole as seen in Table 6-18 [43]. Other than construction, which is almost twice as important to the area's economy as the national average, most industries are close to the national average.

Table 6-18. Employment by industry in the oil shale area, 2005.

	Employment	Distribution, percent	Location Quotient
Natural Resources and Mining	6,385	13.1	10.0
Agriculture, Forestry, Fishing and Hunting	368	0.8	0.9
Mining	6,017	12.4	29.1
Construction	5,187	10.7	1.9
Manufacturing	889	1.8	0.2
Trade, Transportation and Utilities	9,987	20.5	1.1
Information	627	1.3	0.6
Financial Activities	1,868	3.8	0.6
Professional and Business Services	3,032	6.2	0.5
Education and Health Services	2,010	4.1	0.3
Leisure and Hospitality	5,097	10.5	1.1
Other	1,356	2.8	0.8
Government	9,472	19.5	1.2
Total	48,611	100.0	1.0

Source: Bureau of Labor Statistics, *Quarterly Census of Employment and Wages*, November 2006

Production of both crude oil and natural gas has noticeably increased in the past several years this five-county area as listed in Table 6-19 [53,54]. Rio Blanco County, Colorado and Duchesne and Uintah Counties, Utah accounted for 93% of the region's oil production in 2005. When looking at natural gas, Garfield County, Colorado and Uintah County, Utah dominate. These two counties were collectively responsible for 85% of the five-county gas production in 2005.

Table 6-19. Recent oil and gas production in the oil shale area.

Year	Total Oil Shale Area	Component Counties of the Oil Shale Area				
		Garfield County, Colorado	Moffat County, Colorado	Rio Blanco County, Colorado	Duchesne County, Utah	Uintah County, Utah
Crude Oil (thousand barrels)						
2005	17,890	915	258	5,676	6,670	4,371
2004	16,113	764	279	5,511	5,838	3,720
2003	13,848	527	307	5,604	4,341	3,069
2002	13,859	321	345	5,885	4,291	3,016
2001	14,987	230	345	6,237	4,980	3,195
Natural Gas (million cubic feet)						
2005	509,388	269,725	19,148	36,596	20,090	163,831
2004	409,295	209,370	19,399	33,431	14,641	132,455
2003	325,223	149,449	18,451	34,127	11,955	111,241
2002	288,318	116,384	19,177	35,895	12,476	104,386
2001	244,965	88,307	17,486	31,329	13,934	93,909

Note: May not total exactly due to rounding.

Source: Utah Department of Natural Resources, Oil and Gas Program Production Reports, October 2006; Colorado Department of Natural Resources, Colorado Oil and Gas Information System Database, October 2006

The oil shale resources in Colorado, Utah and Wyoming are similar in size to the Canadian oil sands. Therefore, examining economic impacts associated with Canadian oil sands production offers insight when considering the future of oil shale development in the western United States. The Athabasca region in northern Alberta has experienced rapid growth along with the associated socioeconomic stresses as a result of the oil sands industry. The population of the Wood Buffalo Regional Municipality, which contains Fort McMurray, Alberta, increased from 35,213 in 1996 to 51,496 in 2006. The number of private dwelling units increased from 11,895 in 1996 to 20,505 in 2006 [55,56]. There is an additional transient population of approximately 10,000 persons that work in the oil sands industry but live elsewhere [23]. This population growth has strained the housing inventory, with the average single-family dwelling in the Wood Buffalo region costing \$562,200 in May, 2007 compared to \$426,028 in Edmonton, Alberta [57].

Wood Buffalo is a regional municipality in the Athabasca oil sands region in northern Alberta.

Converted from Canadian dollars at the rate of US\$1=C\$1.14253.

The oil shale deposits in Colorado and Utah can support a large industry should technical and economic difficulties be resolved. Various studies and planning documents have forecast an industry producing up to several million BOPD. In America's

Oil Shale: A Roadmap for Federal Decision Making, the DOE stated the vision of a domestic oil shale industry producing 2 million BOPD by 2020 and 3 million BOPD by 2030 [34]. Similarly, in its report Oil Shale Development in the United States: Prospects and Policy Issues, the Rand Corporation analyzed an industry producing 3 million BOPD [29]. To put these production levels in perspective, the United States is currently producing about 5 million barrels of conventional crude oil per day and importing about 10 million BOPD. At a more local level, Utah is producing about 45,000 BOPD, Colorado 60,000 BOPD, and Wyoming 140,000 BOPD. Obviously, the development of an oil shale industry producing millions of barrels of oil per day would cause significant changes in the area's economy.

Using productivity levels for the conventional oil and gas industry as a proxy, an in situ operation producing 100,000 BOPD would require 12,500 workers. Given the uncertainty in the calculation, up to 15,000 persons may be employed in a future oil shale industry that is smaller than some envision. There would be additional employment in businesses supporting the oil shale industry. Using two as a rough employment multiplier, an in situ oil shale industry would result in an additional 25,000 to 30,000 employees in this five-county area. In 2005, this five-county area had 1.73 residents for every member of the labor force residing in the area, suggesting a total population increase for a 100,000 BOPD oil shale industry of 43,250 to 51,900, an increase of 39%-47% over the 2005 population. Current population projections predict that the area will have 213,106 residents in 2030, more than double the estimated population in 2005. These projections are based primarily on current birth rates for the area and do not take into account any population increase due to oil shale production.

A rapid population increase of this magnitude in a rural area such as northeastern Utah and northwestern Colorado will strain the local infrastructure. This infrastructure includes housing, water and wastewater facilities, schools, and roads. Rural counties often have limited tax bases and are unable to cope with rapid growth. Essentially, the increase in tax revenues required to expand infrastructure lags behind the need for new infrastructure. To adequately expand community infrastructure at a rate sufficient to service an oil shale industry, alternative funding mechanisms may be necessary. Possibilities other than local tax increases include funding from the federal government under the many programs for rural development and contributions by industry. These issues have arisen in northern Alberta due to rapid oil sands development. There, the Athabasca Regional Issues Working Group has identified four factors that need to be addressed for continued expansion of the oil sands industry: (1) municipal projects such as water, wastewater, roads and recreational facilities; (2) educational facilities; (3) highways and transportation; and (4) health care and affordable housing [23]. A close working relationship among the oil shale industry, local and regional planners, and regulators will aid in alleviating similar issues in Colorado and Utah.

6.4 New Technology Impacts

North American production of heavy oil, oil sands and oil shale may have significant economic impacts at several levels, from the immediate impact on local economies in producing areas (e.g. rapid in-migration for construction of production facilities) to the larger impacts that the development of these resources may have on the worldwide petroleum industry.

The employment multiplier of two was arrived at by examining the employment direct-effect multiplier from the RIMS II Input-Output model (developed by the Bureau of Economic Analysis, University of Utah) for the area of Daggett, Duchesne, and Uintah Counties, Utah. The Employment Direct-Effect multiplier for this area is 2.38 for Oil and Gas Extraction, 2.09 for Mining Except Oil & Gas, 1.89 for Support Activities for Mining, and 1.62 for Construction. These four multipliers average to 1.99. This area does not exactly correspond to the five-county area examined for oil shale development but has a similar economy.

Advances in economic modeling in the past several decades show the potential to greatly increase the understanding of social and economic impacts resulting from the development of heavy oil, oil sands and oil shale. In analyzing economic and fiscal impacts, static input-output economic models can be used to predict changes in total employment and wages in an area measured as changes to the local economy. Application of these models to the quantification of social and economic impacts resulting from unconventional fuel development will aid in anticipating and addressing social impacts.

Examples of this type of model include the RIMS II model developed by the Bureau of Economic Analysis and the IMPLAN model originally developed by the U.S. Forest Service and refined by Minnesota IMPLAN Group, Inc.

Dynamic time-series models develop a time-series forecast of a regional economy under both baseline conditions and with changes in the local economy such as natural resources development. Application of dynamic models adds the extra dimension of predicting structural changes in an economy over time as the unconventional fuel industry develops and businesses move into the area to supply the production companies.

An example of a dynamic time-series model is REMI Policy Insight developed by Regional Economic Models, Inc.

Additional research and analysis of possible economic and social issues arising from development of oil sands and oil shale resources in Colorado and Utah will aid in mitigating detrimental impacts. Factors to examine include economic impacts such as changes in population, employment and wages, and fiscal impacts such as property tax collections and sales taxes. Forecasts of future changes in employment and wages should include both direct employment at resource companies and indirect and induced employment at suppliers and other local businesses. The timing of future tax revenues should be examined since the demand for social services that accompanies population changes often precedes associated tax revenues. The oil sands and oil shale resources are almost exclusively located in rural areas, where social and economic impacts will often coincide with environmental changes. Future research in social and economic impacts should be coordinated with environmental researchers to properly assess interactions among social, economic and environmental impacts.

The development of oil shale resources in the western United States has the potential to greatly change the world petroleum industry. Research on the capacity and time-frame for future production would be invaluable for purposes of strategic planning and policy development. Additionally, peak oil theory should be revisited in light of the effect that oil shale production would have on the worldwide petroleum supply.

6.5 Refinery Capacity Data by State

Table 6-20. Petroleum refineries in states most likely to produce heavy oil, oil sands and oil shale.

		Atmospheric Crude Oil Distillation		Vacuum Distillation
		Barrels per Calendar Day	Barrels per Stream Day	
Alaska		373,500	404,700	26,900
BP Exploration Alaska Inc	Prudhoe Bay	12,500	14,200	0
ConocoPhillips Alaska Inc	Kuparuk	14,000	16,000	0
Flint Hills Resources Alaska LLC	North Pole	210,000	226,500	5,500
Petro Star Inc	North Pole	17,000	18,000	0
Petro Star Inc	Valdez	48,000	50,000	0
Tesoro Petroleum Corp	Kenai	72,000	80,000	21,400
California		2,026,588	2,132,500	1,240,406
Big West Oil of California	Bakersfield	66,000	68,000	40,000
BP West Coast Products LLC	Los Angeles	260,000	263,000	130,000
Chevron USA Inc	El Segundo	260,000	274,000	143,000
Chevron USA Inc	Richmond	242,901	257,200	123,456
ConocoPhillips Company	Arroyo Grande	44,200	46,500	33,600
ConocoPhillips Company	Rodeo	76,000	80,000	45,000
ConocoPhillips Company	Wilmington	139,000	147,000	82,250
Edgington Oil Co Inc	Long Beach	26,000	40,000	24,000
Exxon Mobile Refining & Supply Co	Torrance	149,500	155,800	102,300
Greka Energy	Santa Maria	9,500	10,000	10,000
Kern Oil & Refining Co	Bakersfield	26,000	27,000	0
Lunday Thagard Co	South Gate	8,500	10,000	7,000
Paramount Petroleum Corp	Paramount	50,000	53,000	30,000
San Joaquin Refining Co Inc	Bakersfield	15,000	25,000	14,300
Shell Oil Products US	Martinez	155,600	158,000	101,000
Shell Oil Products US	Wilmington	95,800	103,500	62,000
Tenby Inc	Oxnard	2,800	4,000	0
Tesoro Refining & Marketing Co	Martinez	166,000	170,000	153,000
Ultramar Inc	Wilmington	80,887	81,000	45,000
Valero Refining California	Benicia	144,000	153,000	89,500
Valero Refining California	Wilmington	6,200	6,500	5,000
Colorado		94,000	104,000	33,500
Suncor Energy (USA) Inc	Commerce City	62,000	68,000	25,000
Suncor Energy (USA) Inc	Denver	32,000	36,000	8,500
Utah		167,350	176,000	43,000
Big West Oil Co	North Salt Lake	29,400	30,000	5,000
Chevron USA Inc	Salt Lake City	45,000	49,000	27,500
Holly Corp Refining & Marketing	Woods Cross	24,700	26,000	5,500
Silver Eagle Refining	Woods Cross	10,250	11,000	5,000
Tesoro West Coast	Salt Lake City	58,000	60,000	0

Source: Energy Information Administration, Refinery Capacity, 2006

Table 6-20 (continued). Petroleum refineries in states most likely to produce heavy oil, oil sands and oil shale.

		Thermal Cracking			
		Delayed Coking	Fluid Coking	Vis-break-ing	Other/ Gas Oil
Alaska		0	0	0	0
BP Exploration Alaska Inc	Prudhoe Bay	0	0	0	0
ConocoPhillips Alaska Inc	Kuparuk	0	0	0	0
Flint Hills Resources Alaska LLC	North Pole	0	0	0	0
Petro Star Inc	North Pole	0	0	0	0
Petro Star Inc	Valdez	0	0	0	0
Tesoro Petroleum Corp	Kenai	0	0	0	0
California		406,700	100,000	5,000	0
Big West Oil of California	Bakersfield	22,000	0	0	0
BP West Coast Products LLC	Los Angeles	65,000	0	0	0
Chevron USA Inc	El Segundo	66,000	0	0	0
Chevron USA Inc	Richmond	0	0	0	0
ConocoPhillips Company	Arroyo Grande	23,400	0	0	0
ConocoPhillips Company	Rodeo	27,000	0	0	0
ConocoPhillips Company	Wilmington	52,200	0	0	0
Edgington Oil Co Inc	Long Beach	0	0	0	0
Exxon Mobile Refining & Supply Co	Torrance	54,600	0	0	0
Greka Energy	Santa Maria	0	0	0	0
Kern Oil & Refining Co	Bakersfield	0	0	0	0
Lunday Thagard Co	South Gate	0	0	0	0
Paramount Petroleum Corp	Paramount	0	0	0	0
San Joaquin Refining Co Inc	Bakersfield	0	0	5,000	0
Shell Oil Products US	Martinez	27,500	22,500	0	0
Shell Oil Products US	Wilmington	40,000	0	0	0
Tenby Inc	Oxnard	0	0	0	0
Tesoro Refining & Marketing Co	Martinez	0	48,000	0	0
Ultramar Inc	Wilmington	29,000	0	0	0
Valero Refining California	Benicia	0	29,500	0	0
Valero Refining California	Wilmington	0	0	0	0
Colorado		0	0	0	0
Suncor Energy (USA) Inc	Commerce City	0	0	0	0
Suncor Energy (USA) Inc	Denver	0	0	0	0
Utah		8,500	0	0	0
Big West Oil Co	North Salt Lake	0	0	0	0
Chevron USA Inc	Salt Lake City	8,500	0	0	0
Holly Corp Refining & Marketing	Woods Cross	0	0	0	0
Silver Eagle Refining	Woods Cross	0	0	0	0
Tesoro West Coast	Salt Lake City	0	0	0	0

Source: Energy Information Administration, Refinery Capacity, 2006

Table 6-20 (continued). Petroleum refineries in states most likely to produce heavy oil, oil sands and oil shale.

		Catalytic Cracking	
		Fresh	Recycled
Alaska		0	0
BP Exploration Alaska Inc	Prudhoe Bay	0	0
ConocoPhillips Alaska Inc	Kuparuk	0	0
Flint Hills Resources Alaska LLC	North Pole	0	0
Petro Star Inc	North Pole	0	0
Petro Star Inc	Valdez	0	0
Tesoro Petroleum Corp	Kenai	0	0
California		723,080	1,000
Big West Oil of California	Bakersfield	0	0
BP West Coast Products LLC	Los Angeles	12,500	0
Chevron USA Inc	El Segundo	74,000	0
Chevron USA Inc	Richmond	90,000	0
ConocoPhillips Company	Arroyo Grande	0	0
ConocoPhillips Company	Rodeo	0	0
ConocoPhillips Company	Wilmington	50,280	0
Edgington Oil Co Inc	Long Beach	0	0
Exxon Mobile Refining & Supply Co	Torrance	100,000	0
Greka Energy	Santa Maria	0	0
Kern Oil & Refining Co	Bakersfield	0	0
Lunday Thagard Co	South Gate	0	0
Paramount Petroleum Corp	Paramount	0	0
San Joaquin Refining Co Inc	Bakersfield	0	0
Shell Oil Products US	Martinez	73,000	0
Shell Oil Products US	Wilmington	36,000	0
Tenby Inc	Oxnard	0	0
Tesoro Refining & Marketing Co	Martinez	70,000	1,000
Ultramar Inc	Wilmington	52,000	0
Valero Refining California	Benicia	75,300	0
Valero Refining California	Wilmington	0	0
Colorado		29,500	500
Suncor Energy (USA) Inc	Commerce City	20,000	0
Suncor Energy (USA) Inc	Denver	9,500	500
Utah		56,900	2,200
Big West Oil Co	North Salt Lake	11,000	0
Chevron USA Inc	Salt Lake City	14,000	0
Holly Corp Refining & Marketing	Woods Cross	8,900	0
Silver Eagle Refining	Woods Cross	0	0
Tesoro West Coast	Salt Lake City	23,000	2,200

Source: Energy Information Administration, Refinery Capacity, 2006

Table 6-20 (continued). Petroleum refineries in states most likely to produce heavy oil, oil sands and oil shale.

		Catalytic Hydrocracking		
		Distillate	Gas Oil	Residual
Alaska		0	12,500	0
BP Exploration Alaska Inc	Prudhoe Bay	0	0	0
ConocoPhillips Alaska Inc	Kuparuk	0	0	0
Flint Hills Resources Alaska LLC	North Pole	0	0	0
Petro Star Inc	North Pole	0	0	0
Petro Star Inc	Valdez	0	0	0
Tesoro Petroleum Corp	Kenai	0	12,500	0
California		228,200	223,400	65,000
Big West Oil of California	Bakersfield	24,000	0	0
BP West Coast Products LLC	Los Angeles	45,000	0	0
Chevron USA Inc	El Segundo	0	51,000	0
Chevron USA Inc	Richmond	0	96,400	65,000
ConocoPhillips Company	Arroyo Grande	0	0	0
ConocoPhillips Company	Rodeo	0	41,000	0
ConocoPhillips Company	Wilmington	26,600	0	0
Edgington Oil Co Inc	Long Beach	0	0	0
Exxon Mobile Refining & Supply Co	Torrance	21,900	0	0
Greka Energy	Santa Maria	0	0	0
Kern Oil & Refining Co	Bakersfield	0	0	0
Lunday Thagard Co	South Gate	0	0	0
Paramount Petroleum Corp	Paramount	0	0	0
San Joaquin Refining Co Inc	Bakersfield	0	0	0
Shell Oil Products US	Martinez	42,000	0	0
Shell Oil Products US	Wilmington	32,000	0	0
Tenby Inc	Oxnard	0	0	0
Tesoro Refining & Marketing Co	Martinez	0	35,000	0
Ultramar Inc	Wilmington	0	0	0
Valero Refining California	Benicia	36,700	0	0
Valero Refining California	Wilmington	0	0	0
Colorado		0	0	0
Suncor Energy (USA) Inc	Commerce City	0	0	0
Suncor Energy (USA) Inc	Denver	0	0	0
Utah		0	0	0
Big West Oil Co	North Salt Lake	0	0	0
Chevron USA Inc	Salt Lake City	0	0	0
Holly Corp Refining & Marketing	Woods Cross	0	0	0
Silver Eagle Refining	Woods Cross	0	0	0
Tesoro West Coast	Salt Lake City	0	0	0

Source: Energy Information Administration, Refinery Capacity, 2006

Table 6-20 (continued). Petroleum refineries in states most likely to produce heavy oil, oil sands and oil shale.

		Catalytic Reforming		Fuels Solvent Deas-phalting
		Low Pressure	High Pressure	
Alaska		13,000	0	0
BP Exploration Alaska Inc	Prudhoe Bay	0	0	0
ConocoPhillips Alaska Inc	Kuparuk	0	0	0
Flint Hills Resources Alaska LLC	North Pole	0	0	0
Petro Star Inc	North Pole	0	0	0
Petro Star Inc	Valdez	0	0	0
Tesoro Petroleum Corp	Kenai	13,000	0	0
California		216,600	233,750	66,000
Big West Oil of California	Bakersfield	16,300	0	0
BP West Coast Products LLC	Los Angeles	10,000	42,000	0
Chevron USA Inc	El Segundo	49,000	0	0
Chevron USA Inc	Richmond	71,300	0	66,000
ConocoPhillips Company	Arroyo Grande	0	0	0
ConocoPhillips Company	Rodeo	0	32,000	0
ConocoPhillips Company	Wilmington	0	36,750	0
Edgington Oil Co Inc	Long Beach	0	0	0
Exxon Mobile Refining & Supply Co	Torrance	0	20,000	0
Greka Energy	Santa Maria	0	0	0
Kern Oil & Refining Co	Bakersfield	0	3,300	0
Lunday Thagard Co	South Gate	0	0	0
Paramount Petroleum Corp	Paramount	0	8,500	0
San Joaquin Refining Co Inc	Bakersfield	0	0	0
Shell Oil Products US	Martinez	31,000	0	0
Shell Oil Products US	Wilmington	0	34,000	0
Tenby Inc	Oxnard	0	0	0
Tesoro Refining & Marketing Co	Martinez	22,000	20,000	0
Ultramar Inc	Wilmington	17,000	0	0
Valero Refining California	Benicia	0	37,200	0
Valero Refining California	Wilmington	0	0	0
Colorado		20,500	0	0
Suncor Energy (USA) Inc	Commerce City	10,500	0	0
Suncor Energy (USA) Inc	Denver	10,000	0	0
Utah		0	37,800	5,040
Big West Oil Co	North Salt Lake	0	7,300	0
Chevron USA Inc	Salt Lake City	0	8,000	0
Holly Corp Refining & Marketing	Woods Cross	0	7,700	5,040
Silver Eagle Refining	Woods Cross	0	2,200	0
Tesoro West Coast	Salt Lake City	0	126,000	0

Source: Energy Information Administration, Refinery Capacity, 2006

6.6 References

- [1] Energy Information Administration. *Annual Energy Outlook 2007*; DOE/EIA-0383(2007); U.S. Department of Energy: Washington, D.C., February 2007. Also available at <http://www.eia.doe.gov/oiaf/aco/index.html>.
- [2] Energy Information Administration. *International Energy Outlook 2007*; DOE/EIA-0484(2006); U.S. Department of Energy: Washington, D.C., May 2007. Also available at <http://www.eia.doe.gov/oiaf/ieo/index.html>.
- [3] Mirtis, G. Special Report EOR/Heavy Oil Survey. *Oil & Gas Journal* April 17, 2006, pp 37-57.
- [4] Sarathi, P.S.; Olsen, D.K. *Practical Aspects of Steam Injection Processes: A Handbook for Independent Operators*; NIPER-580(DE92001070); National Institute for Petroleum and Energy Research: Bartlesville, OK, October 1992.
- [5] Pemex. *Pemex Statistical Yearbook 2006*; Pemex, 2007. Also available at <http://pemex.com/index.cfm?action=content§ionID=11&catID=149&subcatID=2576>.
- [6] Energy Information Administration. Mexico Country Analysis Brief Oil. <http://www.eia.doe.gov/emeu/cabs/Mexico/Oil.html> (accessed May 9, 2007).
- [7] Canadian Association of Petroleum Producers. *Statistical Handbook for Canada's Upstream Petroleum Industry*; 2006-9999; Canadian Association of Petroleum Producers, Sept. 2007. Also available at http://capp.ca/default.asp?V_DOC_ID=1071.
- [8] Energy Information Administration. Domestic Crude Oil First Purchase Prices by Crude Stream. http://tonto.eia.doe.gov/dnav/pet/pet_pri_top.asp (accessed May 9, 2007).
- [9] Berry Petroleum. 2005 Form 10-K. <http://www.bry.com/index.php?page=investor> (accessed January 20, 2007).
- [10] Carrizo Oil & Gas, Inc. 2006 Form 10-K. <http://www.sec.gov/edgar/searchedgar/companysearch.html> (accessed May 17, 2007).
- [11] Berry Petroleum. 2006 Form 10-K. <http://www.bry.com/index.php?page=investor> (accessed May 17, 2007).
- [12] California Division of Oil, Gas and Geothermal Resources. *2000 Annual Report of the State Oil & Gas Supervisor*; California Department of Conservation: Sacramento, California, 2001. Also available at http://www.consrv.ca.gov/dog/pubs_stats/annual_reports/annual_reports.htm.
- [13] California Division of Oil, Gas and Geothermal Resources. *2001 Annual Report of the State Oil & Gas Supervisor*; California Department of Conservation: Sacramento, California, 2002. Also available at http://www.consrv.ca.gov/dog/pubs_stats/annual_reports/annual_reports.htm.
- [14] California Division of Oil, Gas and Geothermal Resources. *2002 Annual Report of the State Oil & Gas Supervisor*; California Department of Conservation: Sacramento, California, 2003. Also available at http://www.consrv.ca.gov/dog/pubs_stats/annual_reports/annual_reports.htm.
- [15] California Division of Oil, Gas and Geothermal Resources. *2003 Annual Report of the State Oil & Gas Supervisor*; California Department of Conservation: Sacramento, California, 2004. Also available at http://www.consrv.ca.gov/dog/pubs_stats/annual_reports/annual_reports.htm.
- [16] California Division of Oil, Gas and Geothermal Resources. *2004 Annual Report of the State Oil & Gas Supervisor*; California Department of Conservation: Sacramento, California, 2005. Also available at http://www.consrv.ca.gov/dog/pubs_stats/annual_reports/annual_reports.htm.
- [17] California Division of Oil, Gas and Geothermal Resources. *2005 Annual Report of the State Oil & Gas Supervisor*; California Department of Conservation: Sacramento, California, 2006. Also available at http://www.consrv.ca.gov/dog/pubs_stats/annual_reports/annual_reports.htm.
- [18] Plains Exploration and Production Company. 2006 Form 10-K. <http://www.sec.gov/edgar/searchedgar/companysearch.html>.
- [19] Energy Information Administration. *Annual Energy Review 2006*; DOE/EIA-0384(2006); U.S. Department of Energy: Washington, D.C., June 2007. Also

- available at <http://www.eia.doe.gov/emeu/aer/contents.html>.
- [20] Energy Information Administration. Natural Gas Prices. http://tonto.eia.doe.gov/dnav/ng/ng_pri_sum_dcu_nus_m.htm (accessed December 4, 2006).
- [21] Guntis, M. California Steam EOR Produces Less: Other EOR Continues. *Oil & Gas Journal*, **2002**, 100(15). pp 48-74.
- [22] Energy Information Administration. California Natural Gas Industrial Prices. <http://tonto.eia.doe.gov/dnav/ng/hist/n3050ca3m.htm> (accessed May 17, 2007).
- [23] Athabasca Regional Issues Working Group; Regional Municipality of Wood Buffalo; Fort McMurray Public Schools; Fort McMurray Catholic Board of Education; Northland School Division; Keyano College; Northern Lights Health Region. *Wood Buffalo Business Case 2005: A Business Case for Government Investment in the Wood Buffalo Region's Infrastructure*; Athabasca Regional Issues Working Group, March 2005. Also available at <http://www.oilsands.cc/pdfs/Wood%20Buffalo%20Business%20Case%202005.pdf>.
- [24] National Energy Board – Canada. *Canada's Oil Sands: Opportunities and Challenges to 2015*; National Energy Board – Canada, Oct. 2000. Also available at <http://www.neb-one.gc.ca/clf-nsi/rnrgynfntn/nrgyrprt/lsnd/lsndsspplymrkt20152000-eng.pdf>.
- [25] National Energy Board – Canada. *Canada's Oil Sands: Opportunities and Challenges to 2015*; National Energy Board – Canada, May 2004. Also available at <http://www.neb-one.gc.ca/clf-nsi/rnrgynfntn/nrgyrprt/lsnd/pprntnsndchllngs20152004/pprntnsndchllngs20152004-eng.pdf>.
- [26] National Energy Board – Canada. *Canada's Oil Sands: Opportunities and Challenges to 2015: An Update*; National Energy Board – Canada, June 2006. Also available at <http://www.neb-one.gc.ca/clf-nsi/rnrgynfntn/nrgyrprt/lsnd/pprntnsndchllngs20152006/pprntnsndchllngs20152006-eng.pdf>.
- [27] Canadian Association of Petroleum Producers. *Bitumen Pricing Methodology for SEC Reserves Disclosure*; Canadian Association of Petroleum Producers, Sept. 2005. Also available at <http://capp.ca/raw.asp?x=1&dt=NTV&c=PDF&dn=91581>.
- [28] Bauman, J. Vernal Company Set to Exploit Oil Shale. *Deseret Morning News*. March 14, 2005.
- [29] Bartis, J.T.; LaTourette, T.; Dixon, L.; Peterson, D.J.; Cecchine, G. Oil Shale Development in the United States; MG-414-NETL; RAND Corporation: Santa Monica, CA, 2005.
- [30] Isaacson, Alan E. Western Oil Shale: Past, Present and Future. *Utah Economic and Business Review* 2006, 66, pp 1-11.
- [31] Russell, P.L. Oil Shales of the World, Their Origin, Occurrence and Exploitation. Pergamon Press: New York, 1990.
- [32] Johnson, H.R.; Crawford, P.M.; Bunger, J.W. *Strategic Significance of America's Oil Shale Resource: Volume II, Oil Shale Resources, Technology and Economics*, AOC Petroleum Support Services, LLC: Washington, D.C., March 2004.
- [33] Bezdek, R.H.; Wendling, R.M.; Hirsch, R.L. *Economics Impacts of U.S. Liquid Fuel Mitigation Options*; DOE/NETL-2006/1237; National Energy Technology Laboratory, July 2006.
- [34] Bunger, J.W.; Crawford, P.M.; Johnson, H.R. *America's Oil Shale: A Roadmap for Federal Decision Making*; Office of Naval Petroleum and Oil Shale Reserves: Washington, D.C., December 2004.
- [35] Energy Information Administration. *Petroleum Marketing Monthly* 2007; DOE/EIA-0380(2007/09); Department of Energy: Washington, D.C., September 2007; p 153. Also available at http://www.eia.doe.gov/oil_gas/petroleum/data_publications/petroleum_marketing_monthly/pmm.html.
- [36] Energy Information Administration. *Refinery Capacity* 2007; Department of Energy: Washington, D.C., June 2007. Also available at http://www.eia.doe.gov/oil_gas/petroleum/data_publications/refinery_capacity_data/refcapacity.html.
- [37] Energy Information Administration. Refinery Capacity and Utilization. http://tonto.eia.doe.gov/dnav/pet/pet_pnp_top.asp (accessed December 13, 2006).
- [38] Energy Information Administration. Movements Between PAD Districts. http://tonto.eia.doe.gov/dnav/pet/pet_move_top.asp (accessed December 13, 2006).

- [39] IOGCC Governor's Task Force. *Rocky Mountain Region Crude Oil Market Dynamics*, Interstate Oil and Gas Compact Commission, January 2007. Also available at <http://www.iogcc.state.ok.us/PDFS/RM-Crude-Oil-Market-Dynamics.pdf>.
- [40] Plains All American Pipeline L.P. 2006 Form 10-K. <http://www.sec.gov/edgar/searchedgar/companysearch.html> (accessed May 10, 2007).
- [41] Smith, C.E. Special Report: Pipeline Economics. *Oil & Gas Journal*, Sept. 11, 2006, pp 46-63.
- [42] Federal Energy Regulatory Commission. *Chevron Pipe Line Company Salt Lake, Crude Pipeline System, Local Pipeline Tariff Governing the Transportation of CRUDE PETROLEUM From Points in Colorado and Utah to Points in Utah*, F.E.R.C. No. 977; Chevron Pipe Line Company: Bellaire, TX, May 31, 2006. Also available at <http://www.chevron-pipeline.com/pdf/FERC977.pdf>. See also http://www.chevron-pipeline.com/crude_all.asp.
- [43] Bureau of Labor Statistics. Quarterly Census of Employment and Wages. <http://stats.bls.gov/cew/home.htm> (accessed November 10, 2006).
- [44] Stryker, A. R.; Wadkins, R.; Olsen, D. K.; Sarkar, A. K.; Ramzel, E.B.; Johnson, W. I.; Pautz, J. *Feasibility Study of Heavy Oil Recovery in the United States*, NIPER/BDM-0225; BDM-Oklahoma, Inc.: Bartlesville, OK, March 1996.
- [45] Bureau of Labor Statistics. Local Area Unemployment Statistics. <http://stats.bls.gov/lau/home.htm> (accessed November 10, 2006).
- [46] Bureau of the Census. Population Estimates. <http://www.census.gov/popest/estimates.php> (accessed May 2, 2007).
- [47] Bureau of the Census. Decennial Census Data. <http://factfinder.census.gov> (accessed November 10, 2006).
- [48] Bureau of Economic Analysis. Local Area Personal Income. <http://www.bea.gov/regional/reis/> (accessed May 2, 2007).
- [49] Alaska Department of Natural Resources, Division of Oil and Gas. *Alaska Oil and Gas Report: Division of Oil and Gas 2006 Annual Report*, Alaska Department of Natural Resources: Anchorage, AK, May 2006. Also available at <http://www.dog.dnr.state.ak.us/oil/products/publications/annual/report.htm>.
- [50] California Department of Finance. Demographic Research Unit. <http://www.dof.ca.gov/Research/Research.asp> (accessed November 15, 2006).
- [51] Alaska Department of Labor and Workforce Development. Alaska Population Projections. <http://almis.labor.state.ak.us/?PAGEID=67&SUBID=115> (accessed November 15, 2006).
- [52] Vanden Berg, M.D. *Annual Review and Forecast of Utah Coal Production and Distribution – 2005*; Open File 481; Utah Geological Survey: Salt Lake City, UT, August 2006. Also available at <http://www.geology.utah.gov/online/ofr/ofr-481.pdf>.
- [53] Utah Department of Natural Resources, Division of Oil, Gas and Mining. Oil and Gas Program Production Reports. http://www.ogm.utah.gov/oilgas/PUBLICATIONS/Reports/report_list.htm (accessed October 24, 2006).
- [54] Colorado Department of Natural Resources, Oil and Gas Conservation Commission. Colorado Oil and Gas Information System Database. <http://www.oil-gas.state.co.us/> (accessed October 24, 2006).
- [55] Statistics Canada. 2001 Community Profiles, Profile for Wood Buffalo Regional Municipality, Alberta. <http://www.12statcan.ca/english/profil01/CP01/Index.cfm?Lang=E> (accessed May 8, 2007).
- [56] Statistics Canada. 2006 Community Profiles, Profile for Wood Buffalo Regional Municipality, Alberta. <http://www.12statcan.ca/english/census06/data/profiles/community/Index.cfm?Lang=E> (accessed May 8, 2007).
- [57] Alberta Employment, Immigration and Industry. *Oil Sands Industry Update*, Government of Alberta, June 2007. Also available at http://www.alberta-canada.com/energyCommodities/files/pdf/oilSandsUpdate_June_2007.pdf.

7

**Environmental, Legal and Policy Issues
Related to Unconventional Fuel**

7 Environmental, Legal and Policy Issues Related to Unconventional Fuel Resource Development on the Public Lands

A wide range of potential environmental resource impacts and land use issues are relevant to the future development of oil shale, oil sands and heavy oil on the public lands. The precise nature and scope of these impacts will vary significantly depending upon where the resources selected for development are located, which technologies are selected to develop these resources, and what environmental impacts and mitigation measures are associated with the relevant technologies.

Heavy oil, primarily produced using steam injection technologies, has an eighty-year production history in the United States. Thus, the environmental and land use impacts associated with heavy oil development are the most predictable of all the unconventional fuel resources.

The picture for oil sands development is less clear. If surface extraction and processing were the production method of choice, development would involve substantial land disturbance to mine the sands, as well as the environmental impacts from on site processing of the sands to extract the bitumen. In Alberta, Canada, surface extraction and processing of oil sands entail enormous land removal activities; about two tons of oil sands must be mined, moved and processed to produce one barrel of synthetic crude oil (SCO) [1]. In addition, 2 - 4.5 barrels of fresh water are required to produce one barrel of SCO [2]. If an in situ technology such as Steam-Assisted Gravity Drainage (SAGD) were the production method of choice (see Section 4.2.3), surface disturbance and water consumption would be reduced. For example, a surface mining site in Alberta leasing 22 square miles (5,701 square kilometers) produces 120,000 BOPD while an in situ site leasing 0.32 square miles (0.83 square kilometers) produces 140,000 BOPD [3]. Because 90-95% of the water used as steam in SAGD is recycled, one barrel of bitumen produced in a SAGD operation requires about 0.2 barrels of fresh groundwater [2].

BOPD refers to barrels of oil produced per day.

The Canadian oil sands model, however, is not entirely analogous to potential oil sands development in the western United States. As noted previously, there are differences in geology and oils sands characteristics between the two regions. Because of these differences, any U.S. oil sands development is likely to be on a much smaller scale than oil sands development in Canada. Additionally, the region of Alberta that has been developed does not enjoy the same legal protections and national status as do the western United States public lands where the oil sands resources are located. To date, there has been no commercial-scale oil sands production in the United States, although some new technologies for extracting oil from the sands have been tested on a small scale (see Section 4.2).

The production processes for extracting oil from oil shale fall into the same two categories as oil sands: (1) mining and surface retorting and (2) in situ technology where the shale is heated in the ground until the oil is released from the shale and can be recovered by pumping. Mining and surface retorting of oil shale will entail substantial surface land disturbance and water consumption (see Section 4.3.2). Estimates of water consumption range from 2.1 - 5.2 barrels of water per barrel of shale oil [4]. In

situ recovery would also result in substantial surface disturbance and water consumption although water consumption is expected to be lower with in situ technologies than with conventional mining and surface retorting. Shell Oil's In situ Conversion Process (ICP), currently being tested at Shell's Mahogany Research Project in Colorado, requires 100% surface disturbance in the test area and, as with other in situ technologies, definitive water consumption estimates are not yet available [4,5]. Although the surface disturbance of in situ extraction is potentially easier to reclaim post-extraction than the surface disturbance that accompanies mining activities, in situ technology has not been implemented on a commercial scale and the range of potential environmental impacts is not yet known. For example, it is unclear what environmental conditions, including the potential for groundwater contamination, will prevail in the shale once the oil has been removed from the ground. Additionally, in situ technology will require substantial amounts of energy (to heat the source rock) and water (to generate power and drill wells), thus raising policy questions as to the "energy in-energy out" calculus of oil shale, the potential greenhouse gas implications of heat generation for in situ recovery, and the feasibility of allocating potentially large quantities of water to oil shale development in the arid West.

Figure 7-1. The White River oil shale mine located south of Bonanza, Uintah County, Utah, is the site of the Utah Lease issued under the Bureau of Land Management's Research Development and Demonstration Leasing program.



Source: Michael Vanden Berg, Utah Geological Survey

Unconventional fuel resource development will involve a wide range of technological options, many of which have only been tested on a small scale, and a similarly wide range of potential environmental and land use impacts. Given these considerable legal variables and environmental uncertainties, this section of the report focuses on the principal laws that inform and frame the legal, environmental and policy backdrop for unconventional fuel resource development. Because these resources are found predominantly on federal public lands, the focus is on the principal federal laws that are relevant to any heavy oil, oil sands, and oil shale development on the public lands. The discussion will also note (where applicable) the state authorities that will govern specific aspects of unconventional fuel resource development efforts.

At present, oil shale and oil sands development are proceeding under specific timelines and mandates set by the Energy Policy Act of 2005 (EPAAct). Heavy oil, which EPAAct references as a strategic unconventional fuel, has been in production for several decades, primarily in California (see Section 4.1). Heavy oil leases are governed by the Bureau of Land Management (BLM) oil and gas regulations already on the books [6]. Recent regulatory changes for heavy oil have been limited to royalty adjustments [7]. Although the EPAAct encourages further development of all strategic unconventional fuels, heavy oil development beyond current production arenas and levels is not under active agency review. Accordingly, this section begins by describing and analyzing the basic legal and policy framework for oil sands and oil shale development as set forth in the Mineral Leasing Act (MLA) and the Combined Hydrocarbon Leasing Act (CHLA), as amended by the EPAAct, keeping in mind that significant pieces of this legal framework are still being developed by the Bureau of Land Management (BLM) in accordance with the deadlines articulated in the EPAAct. Next, this section discusses the environmental analysis requirements and legal standards applicable to oil sands and oil shale development under the National Environmental Policy Act (NEPA) and the Federal Land Policy and Management Act (FLPMA). Finally, this section examines the principal potential impacts that the development of these resources may have on local and regional air, flora and fauna, land and water resources, as well as the laws applicable to these resource values. Significant changes have occurred in the law and in environmental science since the last unconventional fuel resource development frenzy in the late 1970s. Thus, older NEPA documents and other older reports are of limited utility in understanding current legal and environmental issues facing future heavy oil, oil sands and oil shale development.

7.1 General Legal and Policy Framework for Unconventional Fuel Resource Development

7.1.1 Mineral Leasing Act of 1920, as Amended by the Combined Hydrocarbon Leasing Act of 1981 and the Energy Policy Act of 2005.

Prior to the passage of the MLA in 1920 [8], the General Mining Law of 1872 (GML) [9] governed mineral development on the public lands. The GML allowed the prospecting and patenting of “valuable mineral deposits” located on the public lands. Under the GML, a person who discovered a valuable mineral deposit on federal land could acquire fee simple title to the mineral lands at minimal cost and without significant competition from other prospectors, provided that the discoverer complied with minimum federal development requirements and applicable state statutes governing recording and holding mining claims [10]. In 1920, oil shale was specifically brought within the jurisdiction of the MLA and thus converted from a prospectable (hardrock) mineral to a leasable mineral [11].

Fee simple title confers absolute ownership rights.

The BLM has taken steps to extinguish any outstanding unpatented claims under the GML that still could be patented and become fee simple titles.

Under the MLA, the Secretary of the Interior (SOI) is authorized to issue leases for various mineral deposits on the public lands, including oil shale, and such surface land rights as may be necessary to extract the mineral for which the lease has been issued [12]. Under both the MLA and the EPAct, the SOI has discretionary authority as to whether or not to issue mineral leases [12,13]. Historically, the MLA limited oil shale leases to 5,120 acres (20.7 square kilometers) and prohibited both individuals and corporations from holding more than a single lease [14]. These acreage and ownership limitations were modified by the EPAct to allow oil shale leases of 5,760 acres (23.3 square kilometers) and individual or corporate leasing of up to 50,000 acres (202.3 square kilometers) per state [15].

Prior to 1960, there was no legal mechanism for gaining access to oil sands on the public lands. In 1960, Congress amended the MLA to authorize oil sands leases on the public lands [16]. The new oil sand leases, however, created conflicts with conventional oil leases and in 1965, a moratorium was placed on the issuing of separate oil sands leases on the public lands [17]. In 1981, Congress passed the CHLA [18], which redefined “oil” to include oil sands and authorized special leases with specified diligent development requirements in designated Special Tar Sand Areas in Utah (STSAs) [19] as seen in Figure 7-2 [20]. These STSAs are labeled “Designated Tar Sand Areas” and are colored red. At that time, a programmatic environmental impact statement was prepared, and regulations were drafted to implement a leasing program for the designated oil sands areas [21].

Lessees are required to actively and diligently pursue development and extraction of the mineral for which they hold a lease.

Seven STSAs were designated by the United States Geological Survey in accordance with the Congressional directives of the CHLA -- the Pariaette, Sunnyside, Argyle Canyon-Willow Creek, Asphalt Ridge-Whiterocks, Hill Creek, P.R. Spring, and Raven Ridge-Rim Rock STSAs.

Figure 7-2. Oil shale and oil sands deposits in Utah, including STSA and sensitive lands designations.

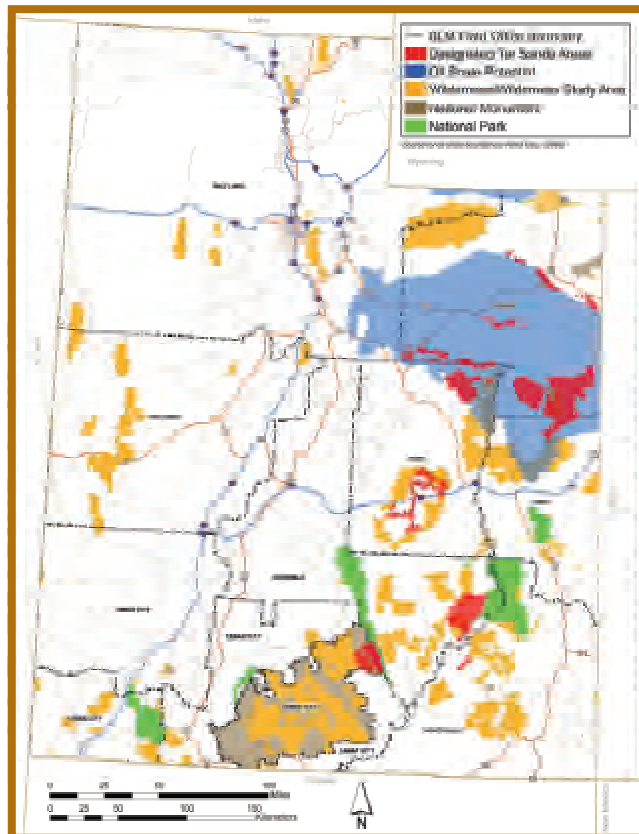

Source: U.S. Department of Interior, Bureau of Land Management, *Utah Oil Shale and Tar Sands Deposits*, 2006

Under this legal framework, the BLM was authorized to issue new combined hydrocarbon leases and to modify existing leases to include oil sands. In 1995, the BLM held a sale of combined hydrocarbon leases, issuing leases on eight parcels covering 13,852 acres (56.1 square kilometers) of STSAs in the Sunnyside and P.R. Spring deposits. However, no significant oil sands development took place under any of the leases [17]. In 2005, the EPAct again separated out the oils sands resource, authorized the BLM to waive diligence requirements for oil sands prospecting leases, and directed the BLM to develop an oil sands leasing program following completion of a new Programmatic Environmental Impact Statement (PEIS), which is now underway [22,23]. As with oil shale, the EPAct increases individual lease acreage available for both combined hydrocarbon leases and for separate oil sands leases to 5,760 acres (23.3 square kilometers) within the STSAs [24].

The BLM remains authorized under the CHLA to issue combined hydrocarbon leases either on its own initiative or in response to industry requests (subject to NEPA and FLPMA). As of September 2006, the BLM had no plans to issue further combined hydrocarbon leases and had received no such applications [17]. More recently, however, the Department of the Interior (DOI) instructed the BLM to reinstate expired oil and gas leases situated in southern Utah, prompting a lawsuit (now pending) filed by a coalition of environmental groups challenging the legality of such reinstatements [25].

7.1.2 Energy Policy Act of 2005

The EPAct seeks to promote accelerated development of “oil shale, tar sands and other unconventional fuels” by declaring it to be federal policy that these resources are “strategically important domestic resources that should be developed to reduce the growing dependence of the United States on politically and environmentally unstable sources of foreign oil imports” [26]. The act also states that “research and commercial development [of these resources] should be conducted in an environmentally sound manner, using practices that minimize impacts . . .with an emphasis on sustainability, to benefit the United States while taking into account affected States and communities” [26]. In debating the language of EPAct and proposed amendments to the act, Congress rejected, on policy grounds, efforts to: (1) categorically exclude development of unconventional resources from environmental analysis obligations under NEPA and the corollary regulations; (2) preclude lease-specific NEPA analysis beyond the PEIS for leases occurring within the decade immediately following completion of the PEIS; and (3) mandate oil shale and oil sands leases on 35% of the geologically promising available public lands within twelve months of finalizing a regulatory framework for oil shale, rather than leaving leasing decisions to the discretion of the SOI following consultation with affected parties [27]. Recent congressional debate has centered on whether to defer commercial leasing and development of oil sands and oil shale under EP Act until more is known about the emerging extractive technologies for these resources [28].

To promote a strategic unconventional fuels program, the EPAct sets forth specific steps for commercial oil shale and oil sands development. Key among these are the completion of a PEIS for an oil shale and oil sands leasing program on public lands located within Colorado, Utah and Wyoming, the implementation of a Research, Development and Demonstration (RD&D) leasing program for oil shale on public lands, and the drafting of federal regulations necessary to govern a commercial federal oil shale leasing program. Pending the recommendations of the Final PEIS as well

The EPAct directed the BLM to prepare a Programmatic Environmental Impact Statement (PEIS) for “a commercial leasing program for oil shale and oil sands on public land” [23].

The leases under consideration for reinstatement are situated within the Grand Staircase-Escalante National Monument, Glen Canyon National Recreation Area and two Wilderness Study Areas.

The RD&D leasing program is a small-scale oil shale leasing program mandated by the EPAct and administered by the BLM. It provides an opportunity to test current oil shale extraction and processing technologies and to evaluate the viability of large-scale oil shale development.

as the outcome of the technologies being tested in the RD&D leases, the BLM is expected to decide whether and where oil shale leases may be issued on public lands. Similarly, upon completion of the PEIS, the BLM is expected to announce whether it will offer competitive commercial oil sands leases [17]. Under the EAct, oil shale and oil sands leasing on public lands is not mandatory, but may proceed at the discretion of the SOI [13].

7.1.2.1 Programmatic Environmental Impact Statement for Oil Shale and Oil Sands Leasing in Colorado, Wyoming and Utah

The BLM, with assistance from Argonne National Laboratory, is currently preparing a PEIS for “a commercial leasing program for oil shale and oil sands on public land” [23]. The PEIS focuses on the oil shale resources in the Piceance and Washakie Basins in Colorado, the Uinta Basin in Utah, and the Green River and Washakie Basins in Wyoming, and on certain oil sands resources in the Colorado Plateau in Utah. According to the PEIS scoping statement, it will identify “appropriate programmatic policies and best management practices to be included in BLM land use plans [and]... will address land use plan amendments in the affected resource areas to consider designating lands as available for oil shale and tar sands leasing and subsequent development activities” [29]. It will also assess the “environmental, social, and economic impacts of leasing oil shale and tar sands resources, including foreseeable commercial development activities on BLM-administered lands located in Colorado, Utah, and Wyoming” as well as “relevant mitigation measures to address these impacts.” [29]. As of the writing of this report, the initial draft of the PEIS has not been released.

7.1.2.2 Research, Development and Demonstration Leases for Oil Shale Technologies

In tandem with the PEIS, the EAct directs the BLM to issue RD&D leases on the public lands [30]. On June 9, 2005, the BLM invited interested parties to submit proposals for 160-acre (0.65 square kilometers) RD&D leases on public lands located in the states of Colorado, Utah, and Wyoming. These RD&D parcels are subject to a ten-year lease term, with a five-year extension option. Royalties are waived for RD&D leases, as are rental fees for the first five years of the lease term. All RD&D lease applicants who can prove the economic feasibility of their oil shale extraction technology are eligible for a preferential right to convert 4960 acres (20.1 square kilometers) contiguous to their initial lease site to a commercial oil shale lease, subject to future BLM review [31]. RD&D leases are limited to the oil shale resource and are not directly relevant to the development of oil sands or heavy oil under the EAct.

The BLM received nineteen RD&D lease nominations, which were ultimately winnowed down to six. In accordance with NEPA, the BLM prepared Environmental Assessments (EAs) for each of the RD&D leases, each resulting in a Finding of No Significant Impact (FONSI). Five of the approved RD&D lease sites are located in Colorado, with the leases held by Chevron Oil Shale Company, EGL Resources, Inc., and Shell Frontier Oil & Gas (which holds three individual lease sites) [33]. On June 14, 2007, Shell announced that it was withdrawing its state mining permit application on one of its RD&D lease sites, and that it would conduct more research at Shell's privately owned Mahogany property (located in Rio Blanco County, Colorado) prior to testing its ICP technology at the RD&D lease site [34]. The remaining lease site is located in Utah and is held by Oil Shale Exploration, LLC [35]. The Colorado proposals all rely on in situ retorting, while the Utah proposal involves a surface retort method.

The goal of the RD&D program is to “advanc[e] knowledge of oil shale recovery technology, evidence of economic viability, and adequate means of managing the environmental impact of oil shale development” [32].

The lease nominations were reviewed by a panel composed of representatives from BLM, the Department of Energy, the Department of Defense, and the States of Colorado, Utah, and Wyoming.

The only environmental conditions imposed on oil shale development by the BLM thus far are found in these RD&D leases, which require that RD&D lessees submit a plan of operations for approval prior to exploration activities on the RD&D parcels that includes “a description of best management practices for interim environmental mitigation and reclamation” [31]. RD&D lessees are required to provide a bond payable to the SOI “sufficient to cover all costs associated with reclamation and abandonment activities,” the amount of which may be increased if deemed necessary by an authorized officer of the BLM [31]. Additionally, RD&D lease operations are subject to the following environmental and natural resources protections:

- (a) The Lessee shall conduct all operations under this lease in compliance with all applicable Federal, State and local statutes, regulations and standards, including those pertaining to water quality, air quality, noise control, threatened and endangered species, historic preservation, and land reclamation, and orders of the authorized officer . . . The Lessee shall employ best management practices to minimize impacts to other resource values.
- b) The Lessee shall avoid, or where avoidance is impracticable, minimize, and where practicable correct, hazards to the public health and safety related to its operations on the Leased Lands.
- (c) The Lessee shall carry on all operations in accordance with approved methods and practices as provided in the operating regulations designated as applicable . . . Activities will be conducted in a manner that minimizes adverse impacts to the land, air, water, cultural, biological, visual, and other resources, including mineral deposits not leased herein, and other land uses and users.
- (d) The Lessee shall comply with all applicable State and Federal laws. [31]

The language and content of future commercial oil shale and oil sands leases is currently at a pre-decisional stage, leaving it unknown what environmental conditions will be included in these leases. Given the environmental stewardship and sustainability language of the EAct, the BLM may decide to impose more rigorous environmental stipulations on a large-scale commercial oil shale or oil sands leasing program, or it may employ additional stipulations on a lease-by-lease basis.

7.1.2.3 Regulatory Framework for Oil Sands and Oil Shale

As required by the EAct, the BLM issued revised oil sands regulations in May 2006 [36]. The revised regulations reflect the modified lease size and the availability of separate oil sands leases; clarify how the regulations apply to combined hydrocarbon leases, oil and gas leases and oil sands leases; authorize the issuance of competitive oil sands leases and competitive and non-competitive oil and gas leases within STSAs; and specify a minimum bid of \$2.00 per acre for oil sands leases [37].

The EAct also directs the BLM to develop the necessary regulatory framework for a commercial oil shale leasing program, requiring the BLM to publish implementing regulations no later than 180 days after release of the Final PEIS [13]. The EAct specifically instructs the BLM to address due diligence standards for oil shale development as well as the economic issue of fair return from royalty and rent payments [38]. Further, the EAct directs that oil shale development must proceed in an environmentally and socioeconomically responsible and sustainable manner [26]. The BLM plans to use as its starting point the 1983 draft oil shale regulations that were released for public comment but never finalized [39]. As much has changed since 1983, all of

The BLM only offers noncompetitive leases when a parcel has been offered for competitive bidding and has failed to receive a bid.

these legal, environmental, economic and technological changes will need to be incorporated into the BLM's forthcoming regulations.

The BLM published an Advance Notice of Proposed Rulemaking in the Federal Register on August 25, 2006, seeking public comments on several issues connected to commercial oil shale leasing [40]. In particular, the BLM requested input on a royalty structure for oil shale, fair market value for conversion of preference-right acreage, fair market value for commercial leasing, diligence standards for commercial oil shale development, and the appropriateness of small tract leasing [40].

Several important policy questions remain open pending finalization of the BLM's oil shale regulations: (1) whether a broad (similar to oil and gas), more specific (similar to coal), or a novel combination regulatory model best suits commercial oil shale leasing and development; (2) whether the regulatory framework for shale should vary depending upon the method of recovery; (3) what standard should be applied to measure the commercial viability of oil shale; (4) what diligence milestones should be set to measure the progress of oil shale development in accordance with section 369(f) of EPAAct; (5) what financial subsidy and royalty structure is appropriate to ensure a fair return as referenced by section 369(o) of EPAAct; (6) how competing rights should be resolved for oil shale and mineral deposits that are co-located on potential lease sites; (7) how existing grazing rights on potential oil shale lease sites should be resolved under the Taylor Grazing Act and the new BLM grazing regulations; (8) what environmental standards should be imposed on commercial oil shale development; and (9) what bonding or other provisions are necessary to insure the availability of reclamation funds at the close of individual oil shale projects.

7.1.3 Summary

The initial legal groundwork for oil shale and oil sands leasing has been set in motion by the EPAAct, but no equivalent environmental impact analysis has yet occurred. Even though oil shale and oil sands are proceeding briskly towards potential leasing and development, several legal, environmental and factual hurdles still stand between the current enthusiasm for development of these resources and actual commercial leasing. These include the completion of a federal regulatory framework for oil shale, analysis of the environmental impacts of the in situ and surface retort oil shale extraction technologies currently being tested in the RD&D leases, and analysis of the environmental and socioeconomic impacts of site-specific commercial development of oil shale or oil sands.

An RD&D leaseholder will have the option to convert an RD&D lease to a commercial oil shale lease and to acquire the adjacent 4,960 acres (20.1 square kilometers) as part of that commercial lease. However, the exact lease rates and terms for such a conversion have not yet been released by the BLM.

Figure 7-3. Utah oil sands with seeping bitumen.

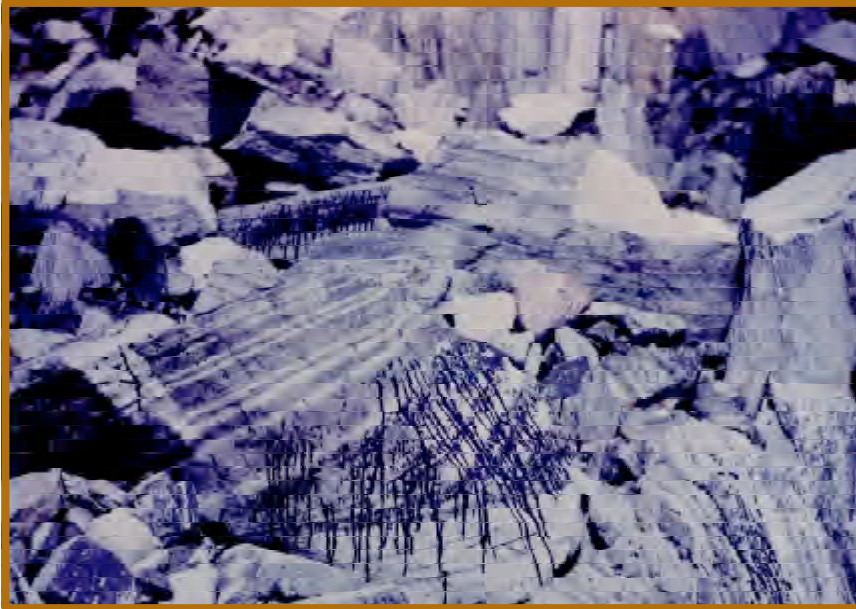

Source: Wally Gwynn, Utah Geological Survey

Figure 7-4. Oil shale from the Green River Formation.



Source: Michael Vanden Berg, Utah Geological Survey

7.2 Existing Environmental Analysis and Land Use Planning Obligations under the National Environmental Policy Act and the Federal Land Policy and Management Act for Commercial Leasing and Development of Unconventional Fuel Resources

The EPAct leaves intact the existing environmental analysis obligations and land use planning standards articulated in NEPA and FLPMA. While the PEIS is designed to satisfy threshold NEPA obligations, additional NEPA analysis will be required for each further stage of unconventional fuel resource development. Similarly, although the PEIS will form the basis for amending land use plans under FLPMA, it will not preclude the need for full FLPMA compliance.

7.2.1 National Environmental Policy Act

NEPA [41] stands as “the basic national charter for protection of the environment” [42], requiring that the environmental impacts of any proposed major federal action that could “significantly affect the human environment” are fully examined prior to implementation of the proposed action [43]. The principal goal underlying NEPA analysis is to “help public officials make decisions that are based on an understanding of environmental consequences, and take actions that protect, restore and enhance the environment” [42]. Additionally, NEPA seeks to involve the public to insure that interested and affected citizens have a voice in the assessment of environmental costs and alternatives implicated by proposed federal actions [44]. While NEPA demands that federal agencies thoroughly assess and weigh the environmental impacts of their proposed actions, NEPA does not compel agencies to avoid environmental impacts [44]. If it is unclear whether or not a proposed major federal action will significantly impact the human environment, NEPA allows for a less comprehensive environmental analysis in the form of an EA, which can result in either a FONSI or preparation of an Environmental Impact Statement (EIS). The BLM deemed EAs the appropriate level of analysis for the oil shale RD&D leases, all of which resulted in FONSIs.

NEPA covers most federal leasing, project, infrastructure, and reclamation decisions.

If a proposed major federal action is likely to have a “significant impact” on the human environment, NEPA regulations mandate completion of an EIS [43]. Under the EPAct, the BLM was congressionally directed to prepare a PEIS to satisfy NEPA requirements and to facilitate commercial oil shale and oil sands leasing by providing a basis for amending existing BLM Resource Management Plans (RMPs) that made little or no provision for such mineral development activity.

RMPs are area-specific, formal management plans written by the BLM to manage and to develop the various resources found on BLM-controlled public lands.

The PEIS will assess the environmental impacts of a commercial oil shale and oil sands leasing and development program in Colorado, Utah and Wyoming. The PEIS will serve several purposes: (1) identify areas of BLM-managed land that will be opened to oil shale and oil sands leasing; (2) establish the constraints under which commercial leasing should proceed; and (3) identify areas of BLM-managed lands that should be closed to oil shale and oil sands leasing [29]. Following the issuance of the Final PEIS, NEPA compliance requirements will continue to attach to the BLM’s individual commercial oil shale and oil sands leasing decisions and to subsequent project development decisions.

Under NEPA and the relevant Council on Environmental Quality (CEQ) regulations, an EIS must address the “direct” anticipated environmental impacts of the action in question, the “indirect” but reasonably foreseeable environmental impacts of the

action in question, and the “cumulative impact” of the proposed action [45,46]. As the overarching goal of NEPA is to impose a proactive layer of environmental analysis on federal decision-making, an EIS must also identify and analyze reasonable alternatives to the proposed action [47]. Reasonable alternatives must be technically and economically feasible, must vary from the proposed action alternative to enable the decision maker to evaluate the full range of environmental options and impacts, and must include the “no action” alternative [48].

As a general rule, the broader the scope of an EIS, the broader the alternatives analysis must be [49].

For NEPA analysis purposes, the direct impacts of a proposed action are defined as “[d]irect effects, which are caused by the action and occur at the same time and place” [45]. Indirect impacts are those “[i]ndirect effects, which are caused by the action and are later in time or farther removed in distance, but are still reasonably foreseeable... [and] may include growth inducing effects and other effects related to induced changes in the pattern of land use, population density or growth rate, and related effects on air and water and other natural systems, including ecosystems” [45].

“Effects” can be ecological, aesthetic, historic, cultural, economic, social or health-related in nature [45].

Cumulative effects are defined as “the impact on the environment which results from the incremental impact of the action when added to other past, present, and reasonably foreseeable future actions regardless of what agency (Federal or non-Federal) or person undertakes such other actions. Cumulative impacts can result from individually minor but collectively significant actions taking place over a period of time” [46]. Recent CEQ guidance clarifies that NEPA documents need not analyze the universe of past, present, and reasonably foreseeable future actions, but only those past, present, and reasonably foreseeable future actions that are “truly meaningful” and that implicate “effects of significance to the proposal for agency action and its alternatives” [48]. To prevent NEPA compliance from becoming unwieldy, cumulative effects analysis can be done in a single EIS, provided that all “connected actions” are addressed [49]. In the case of oil sands and oil shale development, these “connected actions” will likely include amendment of the existing RMPs and leasing and project development decisions, including related access and infrastructure issues.

“Connected actions” are those that “(i) Automatically trigger other actions which may require environmental impact statements; (ii) Cannot or will not proceed unless other actions are taken previously or simultaneously; [or] (iii) Are interdependent parts of a larger action and depend on the larger action for their justification” [49].

One “effect” that must be examined under NEPA is the socioeconomic impact of a proposed action [50]. Socioeconomic concerns related to oil sands and oil shale development raised in the PEIS scoping process include: the specter of another “boom and bust” cycle the likelihood for conflict between short-term employment opportunities in the potential oil sands or oil shale industries and long-term employment opportunities in the existing recreation and tourism industries; the economic realities for local and regional economies to sustain commercial oil sands or oil shale development; the effects of industrial growth on housing, law enforcement, community values, traffic, and property values; the consequences of infrastructure development such as roads, pipelines, rights-of-way, and easements; and the need for financial planning to benefit and protect local communities impacted by large-scale oil shale or oil sands activities on nearby public lands [51]. The PEIS and subsequent leasing-related NEPA analysis should enable the BLM to identify the scale of oil shale and oil sands development and its potential impact at the community level.

Cumulative analysis issues raised in the PEIS scoping process include: other existing and reasonably foreseeable energy development projects involving coal, coalbed methane, oil and gas, wind, and solar energy; regional water use needs and rights; regional water quality concerns; regional air quality concerns; the potential impact of

increased greenhouse gas emissions; regional wildlife habitat degradation and fragmentation; and additional large-scale impacts of new infrastructure, housing subdivisions, increased human populations, and new energy corridors associated with commercial oil shale leasing on the public lands [51].

NEPA also requires federal agencies to identify potential mitigation opportunities that could lessen the environmental impact of a proposed action. Mitigation encompasses (1) avoiding the environmental impacts partially or altogether by eliminating all or part of the proposed action, (2) minimizing the environmental impacts by reducing the scope and implementation of the proposed action, (3) mitigating the impacts through rehabilitation and restoration, (4) diminishing or eliminating the impacts over time by integrating preservation and maintenance measures throughout the term of the proposed action; and (5) compensating for the impacts through replacement or substitute resources or environments [52].

Agencies may tier or segment the scope and timing of their NEPA analysis if segmenting facilitates substantive analysis of the environmental consequences of proposed agency actions [53]. Generally, contemplated agency actions that may relate to a proposed agency action do not need to be included in the NEPA analysis of the proposed action [54]. However, under NEPA, the “synergistic impact of the project should be taken into account at some stage and certainly before the [project] is completed” [55]. Given the various stages of commercial oil shale and oil sands development, NEPA compliance decisions as to the nature and scope of environmental analysis must occur at the planning, leasing, and project approval stages. Failure to do so will likely lay the groundwork for legal challenges to any proposed agency action.

In tiering, one NEPA document is related to another to avoid duplicative efforts.

Absent any oil shale or oil sands case law, the oil and gas leasing NEPA court decisions provide guidance for meeting these NEPA obligations. The courts have generally held that site-specific NEPA analysis must be completed before the BLM can issue an oil or gas lease, unless the BLM stipulates that it retains authority and control over whether and what future lease activities can take place [56]. Where the government seeks to issue a lease that authorizes exploration and development, however, NEPA analysis is required at the leasing stage because the lease represents an “irretrievable commitment of resources” by the government [56,57]. Some, but not all, courts have held that NEPA requires analysis of the no-action or no-leasing alternative before leases can issue, even when those leases stipulate that the BLM retains authority and control over development of the lease [58]. Notably, the 10th Circuit has held that an EIS is not always required prior to issuing oil and gas leases under circumstances where: the BLM retained some authority over the leases in question; EA analysis found that an EIS was not required; and the scope of future drilling activities was “nebulous” [59]. New NEPA analysis is required to update existing RMPs before the BLM can issue leases for minerals not considered for development when the RMP was originally drafted, or when new wilderness-eligibility information is available about the lands at issue [60].

The 10th Circuit is the federal appeals court with territorial jurisdiction over the tri-state area in which oil sands and oil shale development is currently contemplated.

In short, to meet its NEPA analysis obligations, the BLM must balance: (1) the accelerated time frame prescriptions of the EPCA; (2) the technological uncertainties of oil sands and oil shale development; (3) the likely demand for large-scale development in the foreseeable future should the RD&D lease activities demonstrate feasible oil shale extraction technologies; (4) the likelihood that mitigation requirements and related development constraints recommended throughout the PEIS process will create

incentives for cleaner, more sustainable oil sands and oil shale development; (5) the environmental, economic and overall project efficiency benefits of early comprehensive and cumulative analysis of the environmental impacts of large-scale oil shale or oil sands development in the western United States; and (6) the EPLA's directives that oil shale and oil sands be developed in an environmentally conscientious manner. Careful and thorough environmental analysis is more likely to facilitate public involvement, allay fears that current development will repeat past mistakes, limit future development delays due to NEPA, FLPMA or litigation related to the Endangered Species Act (ESA), maximize environmental and socioeconomic stewardship, and ensure that adequate reclamation funds are properly estimated and bonded.

7.2.2 Federal Land Policy and Management Act

The Federal Land Policy and Management Act (FLPMA) establishes the legal framework for management of the BLM public lands [61]. The BLM cannot open any new areas of its public lands for unconventional fuel resource leasing and development unless it has first ascertained that such leasing and development will not compromise its FLPMA land management standards and obligations.

Under FLPMA, the BLM is charged with balancing competing uses of the public lands under the twin “multiple use” and “sustained yield” management standards. The FLPMA “multiple use” mandate requires:

management of the public lands and their various resource values so that they are utilized in the combination that will best meet the present and future needs of the American people; making judicious use of the land . . . to provide sufficient latitude for periodic adjustments in use to conform to changing needs and conditions; the use of some land for less than all of the resources; a combination of balanced and diverse resource uses that takes into account the long-term needs of future generations for renewable and nonrenewable resources . . . and harmonious and coordinated management of the various resources without permanent impairment of the productivity of the land and the quality of the environment with consideration being given to the relative values of the resources and not necessarily to the combination of uses that will give the greatest economic return or the greatest unit output [62].

The FLPMA “sustained yield” mandate requires that the BLM manage their public lands such that there is, in perpetuity, a high-level production or output of the various resources of the public lands, such as timber, minerals and energy [63]. The resource values that the BLM must manage in a manner that satisfies both its multiple use and sustained yield standards include: energy development; mineral extraction; timber; forage; rangeland grazing; recreational opportunities, including fishing, boating, hunting, hiking, biking, snowmobiling, and off-road vehicle use; preservation of historic, paleontological and cultural resources; wildlife and fish conservation, including necessary habitat and vegetation; preservation of wild horse and burro populations; watershed health; and scenic viewsheds [64].

In addition to satisfying FLPMA's “sustained yield” and “multiple use” management mandates, the BLM has further statutory management responsibilities for specially designated areas on the public lands; specifically, wilderness, Wilderness Study Areas (WSAs), Areas of Critical Environmental Concern (ACECs), and Wild and Scenic

Rivers (WSRs). Oil shale and oil sands deposits are in proximity to, and in some instances co-located on, BLM lands with these special designations, creating potentially difficult resource conflicts. The proximity, and in some instances co-location, of sensitive lands including wilderness, WSAs, national parks, and national monuments to oil sands and oil shale resource areas in Utah is illustrated in Figure 7-2.

Wilderness areas, designated by Congress under the Wilderness Act of 1964 [65],

are areas of undeveloped Federal land retaining its primeval character and influence, without permanent improvements or human habitation, which is protected and managed so as to preserve its natural conditions and which (1) generally appears to have been affected primarily by the forces of nature, with the imprint of man's work substantially unnoticeable; (2) has outstanding opportunities for solitude or a primitive and unconfined type of recreation; (3) has at least five thousand acres of land or is of sufficient size as to make practicable its preservation and use in an unimpaired condition; and (4) may also contain ecological, geological, or other features of scientific, educational, scenic, or historical value [66].

The BLM manages wilderness areas primarily to protect their wilderness qualities [67]. Absent a right under a mineral lease that pre-dated the wilderness designation, mineral development cannot proceed in wilderness areas [68].

WSAs are areas on the public lands of 5,000 acres or more that retain their pristine wilderness qualities and that the BLM has recommended for wilderness designation [69]. Under FLPMA, the BLM must manage WSA lands "in a manner so as not to impair the suitability of such areas for preservation as wilderness" [70]. Absent an existing mineral lease, WSAs are excluded from commercial development activities and must be protected from adverse impacts resulting from proximate development activities. The WSAs identified as relevant to the PEIS are located in Utah: Circle Cliffs East and West flanks, Desbrough Canyon, Wolf Point, Bitter Creek, Lower Bitter Creek, P.R. Spring, San Rafael Swell, Sunnyside, Tar Sands Triangle, and White Canyon [51].

ACECs are managed under FLPMA as "areas where special management attention is needed to protect, and prevent irreparable damage to, important historic, cultural, or scenic values; fish or wildlife resources; or other natural systems or processes" [71]. FLPMA directs the BLM to "protect and prevent irreparable damage" to ACEC resources or values in formulating and revising BLM land management strategies [72]. In Utah, ACECs identified as relevant to the PEIS are Main Canyon, Bitter Creek/P.R. Spring, White River, Coyote Basin-Kennedy Wash, Coyote Basin-Snake John, Book Cliffs, Desolation Canyon, Dirty Devil Canyon, Glen Canyon National Recreation Area, Grand Staircase-Escalante National Monument, Nine Mile Canyon, Tavaputs Plateau, and the Pariette Wetlands. In Wyoming, the relevant ACECs are the Red Desert and Washakie Basin, while in Colorado they are the Roan Plateau and Mt. Zirkel Wilderness [51].

WSRs are governed by the National Wild and Scenic Rivers Act of 1968 [73]. They are river segments that have been designated by Congress or by the SOI as meriting special protection and management as part of the Wild and Scenic Rivers System. Eligible WSRs "possess outstandingly remarkable scenic, recreational, geologic, fish and wild-

life, historic, cultural, or other similar values” and, once designated, must be preserved in free-flowing condition [74]. Designated river segments are classified as wild, scenic or recreational and are administered accordingly [75]. Mining activity is not allowed within one-quarter mile of the banks of a “wild” WSR, and, where allowed in the vicinity of a WSR, mining activities must incorporate “safeguards against pollution of the river involved and unnecessary impairment of the scenery within the [WSR] component in question” [76]. Specific rivers identified as relevant to the PEIS are the Colorado River, the Green River, the White River and their tributaries [51].

The SOI designates WSRs upon application by one or more state governors.

The BLM implements its several statutory responsibilities through individual, location-specific RMPs. In developing and revising RMPs, FLPMA directs the BLM to:

- (1) use and observe the principles of multiple use and sustained yield set forth in this and other applicable laws;
- (2) use a systematic interdisciplinary approach to achieve integrated consideration of physical, biological, economic, and other sciences;
- (3) give priority to the designation and protection of areas of critical environmental concern;
- (4) rely, to the extent it is available, on the inventory of the public lands, their resources, and other values;
- (5) consider present and potential uses of the public lands;
- (6) consider the relative scarcity of the values involved and the availability of alternative means (including recycling) and sites for realization of those values;
- (7) weigh long-term benefits to the public against short-term benefits;
- (8) provide for compliance with applicable pollution control laws, including State and Federal air, water, noise, or other pollution standards or implementation plans . . . [77].

The BLM is further required to coordinate and consult with tribal governments, Native American communities, and tribal individuals whose interests might be directly and substantially affected by the RMP [78].

The development and amendment of RMPs generally requires compliance with NEPA through preparation of appropriate environmental analysis documents. The PEIS currently underway will serve as the basis for amending the relevant RMPs to open selected lands to commercial oil shale and oil sands leasing. The PEIS will enable the BLM to assess relevant resource values, special designations, and potential environmental impacts before determining whether to open specific locations to leasing and possible development [51]. Based on the PEIS, the BLM will determine which public lands should be opened to oil shale and oil sands development and under what conditions, which areas should be closed to such development, and whether such closures should be discretionary or non-discretionary. Any proposed RMP amendments based on the PEIS must be submitted for preliminary public comment, cooperating agency review, and state governors’ consistency review. At the conclusion of these processes, these amendments could be challenged in agency administrative appeal procedures and in federal court.

A discretionary closure is potentially available for future development; a non-discretionary closure precludes current and future development.

Consistent with the EPA Act, the Final PEIS will provide the BLM with the authority to amend ten RMPs to permit commercial oil shale or oil sands leasing on specific BLM-managed public lands. In Colorado, these RMPs are the Glenwood Springs

The Cooperating Agencies for the PEIS include the National Park Service; Bureau of Reclamation; U.S. Forest Service; U.S. Army Corps of Engineers; U.S. Fish and Wildlife Service; the States of Colorado, Utah and Wyoming; Garfield, Mesa and Rio Blanco Counties (Colorado); Duchesne and Uintah Counties (Utah); the City of Rifle, Colorado; and the Town of Rangely, Colorado.

RMP (1988, as amended by the Roan Plateau Plan Amendment 2006), the Grand Junction RMP (1987), and the White River RMP (1997, as amended by the Roan Plateau Plan Amendment). In Utah, the affected RMPs are the San Juan Resource Area RMP (1991), the Price Field Office RMP (2006), the Henry Mountain Valley Management Framework Plan (as amended 1997) and the Vernal Field Office RMP (2006). In Wyoming, the affected RMPs are the Kemmerer RMP (1986), the Rawlins RMP (2006), and the Green River RMP (1997, as amended by the Jack Morrow Hills Coordinated Activity Plan 2006). Several of these RMPs encompass sensitive BLM lands that are designated wilderness, WSAs, ACECs, and WSRs, thus raising difficult multiple use and resource priority questions.

7.2.3 Summary

Several important environmental questions should be addressed and answered by the BLM in the PEIS as part of the RMP amendment process, including: (1) what management practices will be established to address the increased air pollution and greenhouse gas emissions anticipated from commercial oil shale and oil sands activities; (2) how will water availability, quantity and use issues within each affected RMP area be resolved; (3) what management practices will be used to monitor and preserve surface and ground water quality during commercial oil shale and oil sands activities; (4) what mitigation standards will be applied for wildlife and habitat within commercial oil shale and oil sands lease areas; (5) how will resource priorities on sensitive lands be resolved and how will the resource values of wilderness, WSAs, ACECs, and WSRs be protected; (6) how will the BLM manage for infrastructure attendant to oil shale and oil sands development, including increased traffic, population growth, and community development within each affected RMP area; (7) what monitoring requirements will be imposed during the various stages of commercial oil shale and oil sands development, and who will be responsible for such monitoring; (8) how will the BLM assess the continuing and cumulative impacts of commercial oil shale development in the long term, including potential layered impacts resulting from expansion of oil shale operations and development of co-located or proximate minerals; (9) what coordination is planned between the BLM, the states, and Native American tribes in order to facilitate and regulate commercial oil shale and oil sands development; and (10) what standards and practices will be employed in reclamation activities connected to commercial oil shale and oil sands development on the public land.

Figure 7-5. Green River Formation oil shale outcropping.



Source: Michael Vanden Berg, Utah Geological Survey

7.3 Legal and Policy Framework for Air Quality Issues and Impacts Related to Unconventional Fuel Resource Development

Several air quality concerns accompany the potential development of unconventional fuel resources, chief among them emission of air pollutants, haze and visibility impairment, and greenhouse gas emissions. Regulation of air pollution and haze occurs under the Clean Air Act (CAA) [79]. Greenhouse gas emissions are not yet regulated under the CAA; however, such regulations are currently under review and are expected to be relevant to any future unconventional fuel resource leasing and development on the public lands [80]. Only those provisions of the CAA that are generally relevant to development of unconventional fuel resources on the public lands are discussed in this section. Given that the BLM has yet to identify specific oil shale or oil sands leasing areas, that it is unknown what technology would be utilized to develop those leases, and that it is unknown what specific environmental impacts and mitigation measures would be associated with the relevant technology, detailed legal analysis under the CAA would be premature.

7.3.1 Clean Air Act

The CAA sets forth the national policy and related legal standards on attainment and preservation of air quality. Under the CAA, the Environmental Protection Agency (EPA) is required to set enforceable federal regulatory standards for defined “criteria pollutants,” hazardous air pollutants, “mobile source” or vehicle emissions, newly constructed sources of pollution (e.g. factories and power plants), and acid rain. CAA compliance is achieved at the state level through state implementation plans (SIPs) and attendant state operating permit programs [81]. In the 1990 amendments to the CAA, Native American tribes were given authority to develop and administer their own air quality implementation plans, subject to EPA approval. States and tribes are free to regulate air quality above but not below the CAA standards [81].

SIPs specify how the individual states will achieve federal air quality standards.

The CAA requires the EPA to regulate “criteria pollutants” that adversely affect human health and to promulgate national ambient air quality standards (NAAQSs) for each such pollutant [82]. Areas with ambient air concentrations of criteria pollutants that fail to meet EPA standards are deemed nonattainment areas [83]. Areas that meet or exceed EPA standards are deemed prevention of significant deterioration (PSD) areas [84]. The central mandate underlying the SIP program is that each state must develop a satisfactory plan to bring nonattainment areas into attainment while preserving the air quality of PSD areas.

At present, the EPA has identified six criteria pollutants: sulfur dioxide, particulate matter, nitrogen oxide, carbon monoxide, ozone and lead.

Differentiated technology-based standards, some of which consider technology-related costs in standard setting and some of which are cost-blind, are applied to various pollutant sources for NAAQSs within nonattainment and PSD areas. These standards are enforced through state-administered permitting systems, which require all major stationary sources (as defined in the CAA and its implementing regulations) and some additional sources to obtain operating permits from the applicable states, subject to possible suspension by the EPA for non-compliance [85]. For example, an existing stationary source in a nonattainment area must employ Reasonably Available Control Technology (RACT) measures to control its emissions and secure the requisite operating permit [86]. A new or modified major stationary source in a nonattainment area must employ Lowest Achievable Emissions Reduction (LAER) technology, a far more stringent requirement [87]. A new major source located within a PSD area is required to employ Best Available Control Technology (BACT), which is more stringent than RACT but less so than LAER.

The EPA is also required to set National Emission Standards for Hazardous Air Pollutants (NESHAPs) based on Maximum Available Control Technology (MACT) for 188 individual hazardous air pollutants [88]. These are minimum standards that do not preclude the EPA from more strictly regulating individual categories of pollutant sources. As with the NAAQSs, major sources of hazardous air pollutants must obtain operating permits from the applicable state agency [89].

The EPA extends special protection to national parks, wilderness areas and other areas of “special natural, scenic, recreational, or historic value” that are designated “Class I” areas under EPA’s PSD regulations [90]. PSD permit analysis generally requires “(1) an assessment of existing air quality, which may include outdoor monitoring data and . . . air quality dispersion modeling, and (2) predictions, using air pollution dispersion modeling, of ambient pollution concentrations that would result from the applicant’s proposed project and future growth associated with the project” [91]. In Class I areas,

permitting requests must be evaluated by the appropriate federal land manager who may recommend denying the permit if the proposed project may have an adverse effect on air quality in the area, even if that effect falls short of violating the actual air quality standards [92]. The EPA has augmented its Class I protections with a National Visibility Goal for the year 2064 for “the prevention of any future, and the remedying of any existing, impairment of visibility in mandatory Class I Federal areas which impairment results from man-made air pollution” [93].

Federal land managers in the tri-state intermountain region include the BLM, the National Park Service (NPS) and the U.S. Forest Service (USFS).

In general, potential oil shale and oil sands leasing and development under the EPOA is currently contemplated on predominantly rural or remote public lands that enjoy high air quality. The BLM’s PEIS scoping analysis shows that potential oil shale areas are in close proximity, and in some instances overlap, wilderness areas, WSAs, and national forests [51]. Certain oil shale deposits in Utah and Wyoming are also in proximity to national parks, while in Colorado there is greater distance between potential oil shale leasing areas and national parklands. The Utah oil sands deposits targeted by the EPOA are proximate to Canyonlands, Arches, Capitol Reef and Dinosaur Monument National Parks, as well as national monuments and WSAs [51].

Air quality standards and permitting obligations will apply at every stage of unconventional fuel resource development. During initial infrastructure development activities, including transportation over unpaved roads, CAA compliance obligations will arise due to fugitive dust and particulate matter pollution. Once actual operations commence, any NAAQS or NESHAPS emissions resulting from resource extraction and production technologies will be subject to regulation, permitting, and monitoring obligations under the CAA.

By way of illustration, air emission sources for the OSEC Utah RD&D lease, which uses surface retorting technology, are expected to include “diesel generators, propane burners, vehicle emissions, fugitive emissions from the recovered product gas streams from the ATP processor, particulates from shale crushing, materials handling and mining activities, on-site equipment, flaring of product gas under emergency conditions...and the small quantities of methane gas seepage from the mine” [94]. Air quality impacts for the Shell Colorado RD&D lease, which uses an in situ method, are expected to result from “vehicle traffic fugitive dust, drilling rigs, facility construction, and vehicle engine exhaust and production (including water and product pumping, processing, and engine exhausts)” [95].

In responding to air quality comments on the RD&D EAs, the BLM noted criticism of the adequacy of the air quality and visibility impacts analyses of RD&D lease activities and identified steps the BLM would take to more stringently analyze and safeguard air quality. For example, the BLM is preparing a less conservative modeling analysis in order to more completely assess potential cumulative visibility impacts on the nearby Flat Tops Wilderness Area and is conducting a regional air quality impact assessment prior to amending the relevant RMP [96]. Additionally, the BLM has emphasized its commitment to imposing strict emissions requirements and to requiring pre-approved air quality monitoring programs as a means of mitigating air pollution resulting from RD&D lease activities on the public lands [96]. Finally, if the RD&D leases yield promising technology that enables large-scale oil shale development to proceed, the BLM will prepare a “more detailed air quality impact assessment. . . using updated air pollutant emissions inventories, meteorological conditions, and dispersion modeling techniques” [96].

Legal questions, compliance and permitting under the CAA are connected to practical time and cost concerns for unconventional fuel resource lessees on the public lands. In Utah, for example, at least one year of pre-construction air quality monitoring will likely be required before the physical groundwork needed for commercial oil shale operations can commence [97]. Similar air quality monitoring would be required throughout oil shale or oil sands development operations, both at specific project sites and downwind of these sites [97]. Serious questions also remain as to what environmental standards the BLM will require for commercial oil shale or oil sands development on the public lands, what (if any) pollution monitoring conditions the BLM will impose on oil shale and oil sands development, and what the eventual pollution control technology costs will be for commercial oil shale and oil sands development.

Due to the proximity of potential oil shale development areas to Class I airshed areas, regional haze and visibility concerns must also be addressed at the leasing and development stages. Both the potentially substantial emissions associated with the energy sources required for extraction and processing of oil sands and oil shale and the cumulative (or layered) regional air quality impacts associated with existing oil and gas operations and with commercial oil shale or oil sands extraction activities will need to be evaluated.

7.3.2 Comprehensive Environmental Response, Compensation and Liability Act

Any threatened or actual releases of hazardous wastes into the environment, including ambient air, at an unconventional fuel development site are potentially subject to the Comprehensive Environmental Response, Compensation, and Liability Act (CERCLA) [98]. CERCLA is the primary federal law governing hazardous waste sites. It sets forth a comprehensive federal framework for the cleanup of hazardous waste sites and imposes liability for cleanup costs on the parties responsible for actual or threatened releases of hazardous substances into the environment.

For purposes of CERCLA, “environment” is defined as “any other surface water, ground water, drinking water supply, land surface or subsurface strata, or ambient air within the United States or under the jurisdiction of the United States” [99].

7.3.3 Greenhouse Gas Emissions

At present, the EPA does not regulate greenhouse gas emissions. However, the Supreme Court of the United States has recently held that greenhouse gas emissions are pollutants under the CAA [100]. In accordance with the Supreme Court decision, President Bush issued an Executive Order directing the Department of Transportation, the Department of Energy, and the EPA to develop regulations to “protect the environment with respect to greenhouse gas emissions from motor vehicles, nonroad vehicles, and nonroad engines, in a manner consistent with sound science, analysis of benefits and costs, public safety, and economic growth” [80]. Although the precise scope and nature of federal greenhouse gas emissions regulations are currently under review, final regulations are likely to be several years away. In addition to potential federal regulations, many states are also seeking to implement greenhouse gas regulations. At present, none of the three states in which unconventional fuel resource development is contemplated currently regulate greenhouse gas emissions.

As the United States is not a party to the Kyoto Protocol, it is not bound by treaty to achieve specific reductions in greenhouse gas emissions. Congress, however, requires that federal agencies, including the BLM, “respond” to climate change issues by utilizing the scientific assessments completed under the 1990 Global Change Research Act (GCRA) [101] when undertaking statutory responsibilities. For the BLM, these

responsibilities include preparation of the oil shale PEIS and implementation of an oil shale or oil sands leasing program on the public lands. The most recent GCRA scientific assessment was provided to Congress in 2000, and the BLM should be incorporating this assessment into its unconventional fuel resource development planning and NEPA analysis. The BLM's responses to comments on the RD&D EAs suggest that while the greenhouse gas emissions resulting from the RD&D program are anticipated to be negligible, the BLM is planning to gather "baseline data" on greenhouse gas emissions associated with in situ oil shale recovery as well as potential mitigation measures [96].

Given the gathering domestic consensus over the need to address climate change at the federal level and the pending formulation of greenhouse gas emissions regulations, it would be irresponsible for the BLM or any of the corporate entities pursuing oil shale and oil sands projects to ignore the greenhouse gas implications of commercial unconventional fuel development. For example, greenhouse gas emissions for oil shale development programs are anticipated to be substantially greater than equivalent oil and gas extraction programs. Hence, the selection of oil shale as a potential mainstay of U.S. energy security raises an array of climate change and energy policy questions. There are some carbon capture and storage technologies that may be relevant to greenhouse gas emissions management in the context of unconventional fuel development. However, these technologies have yet to be subjected to large scale testing [102]. Thus, despite the absence of a specific existing regulatory framework for greenhouse gas emissions, the relationship between climate change and increased greenhouse gas emissions linked to the commercial development of unconventional fuels will undoubtedly affect leasing and project decisions over time.

7.4 Legal and Policy Framework for Flora and Fauna Issues and Impacts Related to Unconventional Fuel Resource Development

Several federally protected animal and plant species reside in the areas of Colorado, Utah and Wyoming that are currently being evaluated as potential oil shale lease areas by the BLM. Still other plant and animal species enjoy state law protection. Particular concerns being addressed in the PEIS are whether and how oil shale and oil sands leasing activities could impact these protected plant and animal species, diminish the quality and quantity of both transitional and winter habitat for local animal species, and simultaneously increase accessibility by hunters, poachers and others to local wildlife [51]. This section will discuss the general legal framework for species protection that would apply to unconventional fuel resource development on the public lands. However, as noted previously, given the many unknowns relative to oil sands and oil shale leases and production technology, detailed legal analysis under the various federal and state laws protecting flora and fauna is premature.

7.4.1 Endangered Species Act

The Endangered Species Act of 1973 (ESA) [103] articulates a strong federal policy to conserve and protect at-risk plant and animal species from extinction. The Fish and Wildlife Service (FWS) and the National Marine Fisheries Service (NMFS) jointly administer the ESA, although only the FWS appears to have jurisdiction over species that might be impacted by oil shale and oil sands development in the tri-state intermountain region. Listed species indexed by taxonomic group, state, region, special status, critical habitat, and recovery plans can be found in the FWS Threatened and Endangered Species System (TESS) [104].

Under the ESA, at-risk species are identified, listed, and classified by the FWS or the NMFS as threatened, endangered or candidate. Species are listed strictly on the basis of their “biological status” and the extent of potential threats to the species’ existence. Five factors inform listing decisions under the ESA: habitat degradation; overuse of the species; disease or predation impacts; the inadequacy of existing regulatory protections for the species; and other natural or human threats to the species survival [105]. At present there are approximately 1,300 listed species receiving protection under the ESA [104]. The ESA also authorizes the designation of critical habitat for listed species in order to ultimately recover and de-list at-risk species [106].

A candidate species is a species likely to be listed in the future as endangered or threatened barring a change of condition.

The ESA protects listed animal species by making it unlawful for anyone to “take” a listed animal unless expressly authorized to do so by federal permit. The “take” protections do not extend to listed plant species, although the ESA does make it unlawful to collect or purposely harm listed plants on federal lands [106]. To escape these strict statutory “no take” provisions, private parties can seek an incidental take permit from the FWS or the NMFS. An incidental take permit will conditionally allow a proposed project to proceed contingent on compliance with specified conservation and mitigation conditions [108].

To “take” a listed animal species includes pursuing, shooting, wounding, killing, trapping, capturing, or collecting or attempting any of the foregoing on federal, state or private lands, as well as altering habitat such that the feeding, breeding and/or sheltering habits of a listed species are impaired [107].

In addition, Section 7 of the ESA imposes a specific conservation duty on federal agencies to further the act’s policy goals and requires all federal agencies to determine in advance whether a planned agency action is likely to affect a listed species or any habitat that has been designated as critical to the species’ survival. When planning such an action, the agency must consult with either the FWS or the NMFS to ensure that the proposed action will not jeopardize a listed species or adversely affect its critical habitat [109].

A Section 7 consultation begins with the FWS or the NMFS issuing a Biological Assessment as to whether the proposed action is likely to impact any listed species or its habitat in the area of the proposed action [110]. If there is likely to be an impact, the FWS or the NMFS then prepares a Biological Opinion analyzing the impacts of the proposed action and providing “reasonable and prudent alternatives” that the consulting agency may employ to alleviate or adequately reduce the threat [110]. “Reasonable and prudent alternatives” are defined as alternative actions that: (1) can be implemented in a manner consistent with the intended purpose of the action; (2) can be implemented consistent with the scope of the action agency’s legal authority and jurisdiction; (3) are economically and technologically feasible; and (4) would, the FWS believes, avoid the likelihood of jeopardizing the continued existence of the listed species or the destruction or adverse modification of critical habitat [110]. Where “reasonable and prudent alternatives” can be agreed upon and incorporated into the proposed agency action, the FWS or the NMFS can allow the action to proceed by issuing an incidental take statement.

Although the ESA is a substantive statute that can compel agencies to mitigate or even forgo actions that adversely impact listed species or designated critical habitat [111], certain agency actions can be exempted from the ESA by the seven-member Endangered Species Committee [112]. Exemptions can be sought by the consulting agency, but only after a good faith consultation and only when the Committee finds that there are no reasonable and prudent alternatives, the proposed action is in the public interest and is of regional or national significance, and the benefits of pursuing

the action clearly outweigh the benefits of conserving the species at issue or its habitat. Exemptions are rarely granted.

The ESA requires that the FWS or the NMFS be consulted at the leasing stage to determine the potential impacts of each proposed lease on listed and candidate species in the lease area, beginning with operational siting decisions and continuing with transportation, infrastructure and operational impacts. This consultation must consider not only the impact of leasing, but also the likely impacts of potential commercial development scenarios [109,110]. As a result, analysis of affected species and habitat, including baseline population assessments, must be conducted. Section 7 consultations for oil shale or oil sands leases will likely lead to obligatory mitigation measures in the form of agreed upon “reasonable and prudent alternatives” as well as monitoring requirements. As individual projects proceed to the development stage, monitoring obligations will become increasingly important to ensure that the mitigation measures are working as intended. In short, the FWS will be an active participant throughout any commercial oil sands or oil shale development process.

7.4.2 Migratory Bird Treaty Act; Bald Eagle Protection Act

Further legal protections exist for certain species beyond the protections provided by the ESA. Of greatest relevance to the tri-state region where unconventional fuel resource development is currently contemplated are the Migratory Bird Treaty Act of 1918 (MBTA) [113] and the Bald Eagle Protection Act of 1940 (BEPA), as amended [114]. The MBTA offers federal protection for all migratory birds, including “waterfowl identified as high or moderately high continental priority in the North American Waterfowl Management Plan” and “game birds below desired population sizes” [113]. BEPA extends federal legal protection to bald and golden eagles [114]. As with the ESA, the FWS administers the MBTA and the BEPA and will require mitigation of activities that may adversely affect species protected under either act.

7.5 Legal and Policy Framework for Land Management Issues and Impacts Related to Unconventional Fuel Resource Development

In addition to the land management issues discussed in the context of NEPA and FLPMA, four other land-related issues are relevant to commercial oil sands and oil shale development. First is the issue of physical land displacement in oil sands and oil shale mining and surface retorting operations. These resources are located in remote areas and, as noted earlier, are proximate to wilderness areas, WSAs, ACECs and WSRs. Substantial land disturbance in these locations raises not only FLPMA and ESA compliance issues, but also broader policy questions as to the balance between preserving existing landscapes and developing energy resources on the public lands.

Second is the related issue of surface impacts resulting from installing the physical infrastructure for and providing the energy to either mining and surface retorting or in situ operations. Other surface impacts include the necessary network of roads and pipelines to transport the bitumen or shale oil to refineries and markets. The BLM has not yet released its evaluation of the anticipated environmental consequences of the industrial infrastructure required to support commercial oil sands and oil shale industries. The environmental impacts of land displacement and the infrastructure requirements of any commercial oil sands or oil shale leasing operation would be subject to NEPA and FLPMA analysis, as well as CAA, ESA, and Clean Water Act (CWA) compliance.

The third issue is the generation, management and disposal of any hazardous and nonhazardous solid wastes resulting from the various stages of unconventional fuel development. Such wastes are subject to regulation under the Resource Conservation and Recovery Act (RCRA) [115]. Any threatened or actual releases of hazardous wastes on or into land surfaces or subsurfaces at an unconventional fuel development site are potentially subject to CERCLA [98,99].

The fourth issue is land ownership. While oil shale and oil sands resources are predominantly located on federal land, these federal lands are interspersed with state, tribal and private lands. Construction of industrial infrastructure and management of the environmental impacts of unconventional fuel development may require obtaining rights of way and access to nearby state, tribal or private lands. The role non-federal lands might play in the development of these resources should become apparent once the BLM completes its final PEIS analysis and identifies potential commercial leasing sites and transport options.

7.6 Legal and Policy Framework for Water Issues and Impacts Related to Unconventional Fuel Resource Development

Water quality, quantity, allocation and availability are all relevant to any oil sands and oil shale development contemplated under the EPAct. The Clean Water Act (CWA), the Safe Water Drinking Act (SWDA), the Colorado River salinity compacts, and state water quality laws will govern water pollution issues resulting from unconventional fuel resource development. As noted above, any threatened or actual releases of hazardous wastes into surface water, ground water or the drinking water supply are potentially governed by RCRA [115,116] and CERCLA [98,99]. The CWA also governs wetlands protection as well as any dredge and fill activities. The Law of the River, the ESA (and equivalent state protections), and the physical limitations of the Colorado River will determine if and how much water in the system is available for oil sands or oil shale development. Finally, the potential allocation of water for oil shale and oil sands development in the arid West will present significant policy questions, particularly if the technologies selected to develop these resources are highly water-consumptive.

At present, the consumptive water demands for either commercial oil sands or oil shale operations have not been definitively established. In Alberta, surface mining and processing requires 2 - 4.5 barrels of water to produce one barrel of SCO [2]. Conventional mining and surface retort shale production methods are estimated to need between 2.1 - 5.2 barrels of water to produce one barrel of oil [4]. In situ production methods for oil shale, which have not yet been tested on a commercial scale, are estimated to require fewer barrels of water to produce one barrel of shale oil than conventional mining and processing; however definitive water consumption needs for in situ technologies have not yet been established [4,5]. Past RMP analysis conducted by the BLM concluded that water consumption for oil shale development could lead to as much as an 8.2% reduction in the annual flow of the White River [117].

Given the many unknowns relevant to oil sands and oil shale leases and production technology, detailed analysis under these legal authorities would be premature. Instead, the discussion will outline the general legal framework that will govern and inform water resource issues in the context of unconventional fuel resource development under the EPAct.

The Law of the River refers to the laws that govern the management, use, and interbasin allocation of Colorado River water.

The White River is located in northeastern Utah.

7.6.1 Clean Water Act

The CWA [118] was enacted “to restore and maintain the chemical, physical, and biological integrity of the Nation’s waters” [119]. To that end, the CWA seeks to control and eliminate discharges of pollutants into the waters of the United States, to restore those waters to “fishable and swimmable” conditions such that they can support “the protection and propagation of fish, shellfish, and wildlife and recreation in and on the water,” and to fund and develop waste treatment facilities and pollution control programs [119]. The objectives of the CWA are met through a combination of federal, state and local programs aimed at regulating point and nonpoint pollution sources and evaluating water quality. The CWA regulates surface water quality only; it does not regulate groundwater quality, nor does it address issues of water quantity or depletion.

The CWA looks to the states to develop water quality standards (WQs) that meet the goals of the CWA, subject to approval by the EPA [120]. States then monitor their waterbodies and evaluate whether the applicable WQs are met. For those waterbodies that meet the WQs, states are required to develop anti-degradation programs that will maintain and preserve existing water quality. Where the water quality falls below the WQs, states must develop a program designed to bring it in line with applicable WQs. States usually develop a Total Maximum Daily Load (TMDL) program, which determines what pollutant loads must be achieved to meet WQs and how best to allocate the loads among the pollutant sources [120]. A TMDL strategy typically employs a variety of permitting and monitoring programs to restrict pollutant discharges and to evaluate water quality. All states must biennially inventory and monitor the quality of their waters relative to the goals of the CWA [121].

In addition to pollution control measures, the CWA also governs dredging and filling of wetlands [122]. The CWA requires avoidance and mitigation of wetlands impacts and compensatory mitigation of any unavoidable wetland impacts [122].

7.6.2 Safe Water Drinking Water

The objective of the Safe Water Drinking Act of 1974, as amended (SWDA) [123], is to safeguard the water quality of community water systems by regulating the water characteristics and the maximum acceptable levels of various chemicals in the water systems [124]. Once the EPA has issued water quality standards under the SWDA, it is the responsibility of the states to enforce them and to monitor the water quality. The SWDA governs not only surface and groundwater connected to a community water system, but also the watersheds that directly impact the water supply [125]. Under the SWDA, states have the authority to designate and stringently regulate sole-source aquifers and other watersheds deemed critical to the drinking water supply [126]. The SWDA also regulates underground injection activities by permit [126].

7.6.3 Colorado River Basin Salinity Control Act

Under the Colorado River Basin Salinity Control Act of 1974, as amended (CRBSCA) [127], the Colorado River is subject to water quality standards for salinity in accordance with the CWA and the United States’ water quality obligations to the Republic of Mexico. The CRBSCA is administered by the SOI, acting through the Bureau of Reclamation. The EPA plays a regulatory role in application of the CRBSCA because it must approve or disapprove the water quality standards for salinity adopted by the seven Colorado River Basin states (see Figure 7-6). Salinity will be an issue both

As defined in the CWA, “waters of the United States” encompasses only surface waters, rivers, lakes, estuaries, coastal waters, and wetlands.

Point source pollution refers to pollutants conveyed through discrete points (such as pipes or ditches) and discharged into the waters of the United States. Nonpoint pollution results from rainfall or snowmelt traveling over and through the ground, absorbing both manmade and natural pollutants, and eventually transporting these pollutants to various waterbodies.

WQs define waters in terms of designated water uses, water quality criteria, and antidegradation provisions

The Army Corps of Engineers administers permits related to dredging and filling of wetlands. The Corps defines wetlands as areas that are periodically or permanently inundated by surface or ground water and support vegetation adapted for life in saturated soil. Wetlands include swamps, marshes, bogs and similar areas.

A community water system has fifteen or more connections and serves twenty-five or more people.

An overview of the Colorado River Basin Salinity Control Program, including the United States’ specific water delivery obligations to Mexico, can be found at [128].

during extraction operations and in connection with the disposal of spent shale [51]. Analysis completed by the Office of Technology Assessment in 1980 estimated that a one million BOPD oil shale industry could increase salinity levels in the Lower Basin between 0.2% - 2.4% [129]. Salinity levels have been identified as an issue of concern in the PEIS scoping process [51], and any unconventional fuel resource development in the Colorado Basin will need to incorporate salinity control measures adequate to comply with the CRBSCA.

As the BLM has yet to identify specific oil sands or oil shale leasing areas, it cannot be anticipated with any specificity which surface waters, watersheds or wetlands would likely be impacted by commercial oil shale or oil sands development activities. Thus far, water quality issues related to unconventional fuel resource development have been analyzed primarily in the context of the RD&D leases. The RD&D EA analysis suggests that surface and ground water quality could be impacted by: (1) discharges of processed or other waters with high salinity or other pollutants as a result of leaks, spills, or heavy rainfall; (2) leakage or overflow of process wastes from storage ponds used to store or treat liquids; (3) dewatering activities; (4) water reclamation activities involving re-injection of water that was previously extracted; and (5) failure to properly plug wellbores at the conclusion of an in situ shale production process [130]. Scoping comments for the PEIS raised concerns that highly saline runoff could be toxic to the flora and fauna of proximate streams and rivers, that the elevated temperature and composition of discharged wastewater could harm riparian ecosystems, and that leachate from the process wastes could cause contamination of groundwater and surface waters [51].

At a minimum, water quality protection measures that will apply to RD&D lease activities, and presumably to any future large-scale commercial unconventional fuel resource extraction, include a variety of CWA permits; development of a BLM-approved spill prevention plan; development of a Stormwater Management Plan to control runoff and sediment transport; development of a BLM-approved surface water monitoring plan to demonstrate whether specified environmental protection measures are being met; construction of a surface water drainage and management system; development of a BLM-approved groundwater monitoring and response program to be in effect during and after lease operations; and implementation of erosion and sediment control measures [130].

7.6.4 Law of the River

The water in the Colorado Basin is allocated among the Upper and Lower Basin States (see Figure 7-6) [131] and the Republic of Mexico pursuant to the Colorado River Compact of 1922, the Boulder Canyon Project Act of 1928, the Upper Colorado River Basin Compact of 1948, the 1964 Decree and the 1979 Supplemental Decree issued by the Supreme Court in *Arizona v. California*, and the Mexican Water Treaty of 1944. Mexico is guaranteed by treaty 1.5 million acre-feet of Colorado River water annually (58.7 cubic meters per second (m^3/s)), which may increase or decrease subject to conditions specified in the treaty. Due to shifting and increased population demands, as well as recent dry weather conditions and dropping reservoir levels, the historical Upper and Lower Basin State allocations, totaling 15 million acre feet per year (587 m^3/s), have been the subject of much debate and study. When the allocations were negotiated, it was anticipated that the Colorado River had an average flow of 16.4 million acre feet per year (641 m^3/s) [132]. More current data suggests, however, that

Required CWA permits might include Discharge Permits from the appropriate state water quality agency, Storm Water Permits, Industrial Wastewater/Produced Water Permits, and Section 404 Permits.

A surface water drainage system directs storm water flows into a storm water pond before the water is discharged through the existing surface drainage system of ditches, storm sewers, culverts, curbs, and paving.

The 1928 Boulder Canyon Project established the following annual State allotments: Upper Basin: Colorado, 51.75% / 3.88 million acre feet per year (152 m^3/s); Utah, 23.00% / 1.73 million acre feet per year (68 m^3/s); Wyoming, 14.00% / 1.05 million acre feet per year (41 m^3/s); New Mexico, 11.25% / 0.84 million acre feet per year (33 m^3/s); and Arizona, 0.70% / .05 million acre feet per year (2.0 m^3/s) and Lower Basin: California, 58.70% / 4.40 million acre feet per year (172 m^3/s); Arizona, 37.30% / 2.80 million acre feet per year (109 m^3/s); and Nevada, 4.00% / 0.30 million acre feet per year (12 m^3/s) [132].

a realistic average water flow estimate is 13.5 million acre feet per year (528 m³/s). The Compact signatories and the federal government have recently focused on what management and conservation strategies are necessary to ensure that the Colorado River can continue to meet the anticipated water needs of the Basin States.

Figure 7-6. The Colorado River Basin.

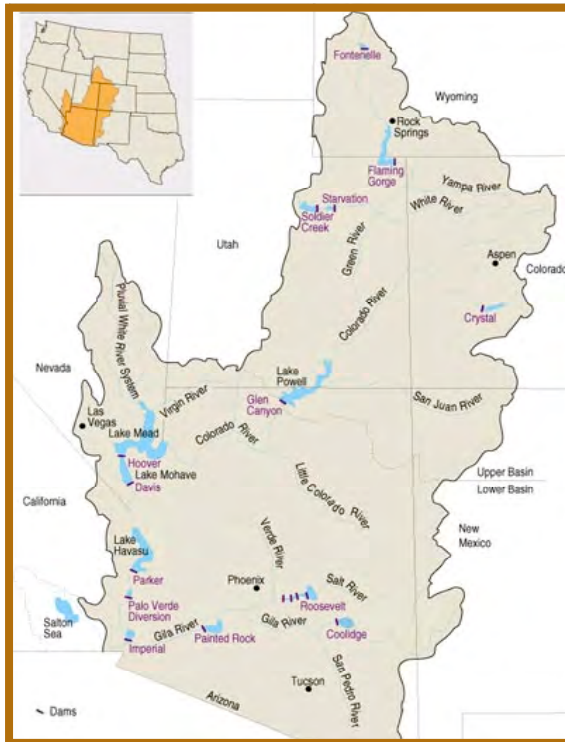

The Colorado River Compact designated Lee's Ferry, located approximately 30 river miles (48.2 kilometers) south of the Utah-Arizona boundary, as the dividing line between the Upper Basin and Lower Basin States.

Source: U.S. Department of Interior, Colorado River Programs and Projects

Moreover, within Colorado, Utah and Wyoming, most of the surface waters have been allocated under prevailing state law water regimes. This is the context in which the water demands of an emerging oil sands or oil shale industry must be considered. Should commercial development proceed, possible water sources in the Colorado River Basin are water rights purchased from existing owners subject to applicable state water laws or allocation by Colorado or Utah of any unused Colorado River allotments specifically for the development of an oil sands or oil shale industry.

7.6.5 Endangered Species Act

The ESA will be relevant to issues of water quantity and removal from the Colorado River system as any depletion will likely impact critical habitat for federally-protected aquatic species. Decade-old analysis completed by the BLM determined that developing a large-scale oil shale industry in the Piceance Basin would require significant water resources, which “would result in the permanent loss or severe degradation of nearly 50% of BLM stream fisheries” [117]. It is not possible to evaluate the extent to which ESA protections, and thus consultation with the FWS, will be relevant to future issues of water quantity and depletion until actual water demands for commercial oil sands or oil shale operations are quantified, and water sources to meet those demands are identified.

Federally protected aquatic species include humpback chub, bonytail chub, Colorado pike-minnow and razorback sucker.

7.7 Reclamation

The scope of reclamation obligations that will arise from unconventional fuel resource development will depend in substantial measure on the extraction and processing technologies that are employed in developing these resources. As discussed previously, unconventional fuel resource development has the potential to significantly disturb and damage air, land, wildlife, and water resources. How much of that potential disturbance can be mitigated or avoided entirely through technological advancement is not yet known. Moreover, the tri-state area in which oil sands and oil shale development is currently contemplated under the EPO Act is a physically challenging environment in which to attempt reclamation due to the nature of the topsoil, the climate, and the limited water supply [133]. The BLM will require unconventional fuel resource lessees to develop and file reclamation plans that comply with BLM Surface Management regulations and state reclamation laws, and will require unconventional fuel resource lessees to post bonds in amounts adequate to cover the costs of their proposed reclamation plans [134].

7.8 References

- [1] Government of Alberta, What is Oil Sands, 2007. <http://www.energy.gov.ab.ca/100.asp> (accessed August 15, 2007).
- [2] National Energy Board – Canada. *Canada's Oil Sands: Opportunities and Challenges to 2015: An Update*; National Energy Board – Canada, June 2006. Also available at <http://www.neb-one.gc.ca/clf-nsi/rnrgynfmrtn/nrgyrprt/lsnd/pprntnsndchllngs20152006/pprntnsndchllngs20152006-eng.pdf> (accessed August 15, 2007).
- [3] Government of Alberta, Oil Sands, 2006. <http://www.gov.ab.ca/env/land/quality/html/use/oilsands.html> (accessed August 15, 2007).
- [4] Bartis, J. T.; LaTourette, T.; Dixon, L.; Peterson, D. J.; Cecchine, G. *Oil Shale Development in the United States*; MG-414-NETL; RAND Corporation: Santa Monica, California, 2005.
- [5] Shell Oil Company, Mahogany Research Project: Doing Oil Shale the Right Way, February 2007. http://www.shell.com/static/us-en/downloads/shell_for_businesses/exploration_production/icp_fact_sheet_final.pdf (accessed August 15, 2007).
- [6] Oil and Gas Leasing, 43 C.F.R. §§ 3100 – 3109.3 (2006).
- [7] See 43 C.F.R. § 3103.4-3; Oil and Gas Leasing; Fees, Rentals and Royalty, 70 Fed. Reg. 21810 (April 27, 2005).
- [8] Mineral Leasing Act of 1920, 30 U.S.C. § 181 *et seq.*
- [9] General Mining Law of 1872, 30 U.S.C. § 22 *et seq.*
- [10] 30 U.S.C. § 28; see *Cliffs Sympuel Corp. v. Norton*, 291 F.3d 1250 (10th Cir. 2002).
- [11] 30 U.S.C. § 181.
- [12] 30 U.S.C. § 241(a); *Udall v. Tallman*, 380 U.S. 1 (1965).
- [13] Energy Policy Act of 2005 § 369(e) (codified at 42 U.S.C. § 15927(e)).
- [14] 30 U.S.C. § 241(a).
- [15] Energy Policy Act § 369(j)(2).
- [16] Pub. L. 86-705 (1960); see 30 U.S.C. § 181.
- [17] Comments of James Kohler, Bureau of Land Management, Heavy Oil Resources of Utah: The Historic Perspective, Western U.S. Oil Sands Conference, September 21, 2006, Salt Lake City, Utah.
- [18] Combined Hydrocarbon Leasing Act, 30 U.S.C. § 226.
- [19] See Geological Survey: Designations of Tar Sand Areas, 45 Fed. Reg. 76800 (Nov. 20, 1980); Geological Survey: Designations of Tar Sand Areas, 46 Fed. Reg. 6077 (January 21, 1981).
- [20] Oil Shale and Tar Sands Leasing Programmatic EIS Information Center, Utah Oil Shale and Tar Sands Deposits. http://ostseis.anl.gov/documents/maps/OSTS002_UtahTarSands.pdf (accessed August 15, 2006).

- [21] *See* Combined Hydrocarbon Leasing; Conversion of Existing Oil and Gas Leases and Valid Claims Based on Mineral Locations, 47 Fed. Reg. 22474 (May 24, 1982); Combined Hydrocarbon Leasing; Procedure for the Leasing of Combined Hydrocarbon Resources, 48 Fed. Reg. 7420 (Feb. 18, 1983); 43 C.F.R. § 3140 (2006).
- [22] Energy Policy Act of 2005 § 350 (codified at 42 U.S.C. § 15908).
- [23] Energy Policy Act § 369(d).
- [24] Energy Policy Act § 369(j)(1).
- [25] Southern Utah Wilderness Alliance, BLM May Allow Disastrous “Tar Sands” Development on Expired Oil & Gas Leases in Grand Staircase-Escalante National Monument: Conservation groups file lawsuit, calling BLM’s decision illegal, March 14, 2007. http://www.suwa.org/site/News2?JServSessionIdr007=37dyo6tsg3.app14b&page=NewsArticle&cid=5993&security=1&news_iv_ctrl=1061 (accessed August 15, 2007).
- [26] Energy Policy Act § 369(b).
- [27] *See* H.R. 6, 109th Cong. § 1018 (1995); S. 1932, 109th Cong. § 6031 (1995). For a more detailed analysis of the legislative history of the EPLA, *see* Comments of Robert W. Randall, Western Resource Advocates, The changing legal landscape for leasing of Federal oil shale resources, Proceedings of the 26th Annual Oil Shale Symposium, October 16-18, 2006, Golden, CO.
- [28] Suzanne Struglinksi. House amends oil-shale bill. *Deseret Morning News*. June 8, 2007.
- [29] Oil Shale and Tar Sands Programmatic EIS Information Center, What’s in the Oil Shale and Tar Sands Leasing Programmatic EIS. <http://ostseis.anl.gov/index.cfm> (accessed August 15, 2007).
- [30] Energy Policy Act § 369(c).
- [31] Potential for Oil Shale Development; Call for Nominations-Oil Shale Research, Development and Demonstration (R, D & D) Program, 70 Fed. Reg. 33753 (June 9, 2005).
- [32] News Release, Bureau of Land Management, *BLM Announces Results of Review of Oil Shale Research Nominations* (Jan. 17, 2006). Also available at http://www.blm.gov/nhp/news/releases/pages/2006/pr060117_oilshale.htm.
- [33] News Release, Bureau of Land Management, *Interior Department Issues Oil Shale Research, Development and Demonstration Leases for Public Lands in Colorado* (Dec. 15, 2006). Also available at http://www.blm.gov/nhp/news/releases/pages/2006/pr061215_oilshale.htm.
- [34] Nancy Lofholm. Shell shelves oil-shale application to refine its research. *Denver Post*. June 16, 2007.
- [35] News Release, Bureau of Land Management, *Interior Department Issues Oil Shale Research, Development and Demonstration Lease for Public Lands in Utah* (June 28, 2007). Also available at http://www.blm.gov/ut/st/en/info/newsroom/2007/06/interior_department.html.
- [36] Leasing in Special Tar Sand Areas, 70 Fed. Reg. 58610 (Oct. 7, 2005); (same), 71 Fed. Reg. 28778 (May 18, 2006).
- [37] 43 C.F.R. §§ 3140-3142 (2006).
- [38] Energy Policy Act of 2005 § 369(o) (codified at 42 U.S.C. § 15927(o)).
- [39] Comments of James Kohler, Bureau of Land Management, SPE-UGA Oil Shale Conference, May 19, 2006, Salt Lake City, Utah. *See also* 48 Fed. Reg. 6510 (Feb. 11, 1983).
- [40] Commercial Oil Shale Leasing Program, 71 Fed. Reg. 50378 (Aug. 25, 2006).
- [41] National Environmental Policy Act of 1969, 42 U.S.C. §§ 4321-4370d.
- [42] 40 C.F.R. § 1500.1(a).
- [43] 42 U.S.C. § 4332(2)(C); 40 C.F.R. § 1508.27.
- [44] *Robertson v. Methow Valley Citizens Council*, 490 U.S. 332, 349-351 (1989).
- [45] 40 C.F.R. § 1508.8.

- [46] 40 C.F.R. § 1508.7; *see also* *Neighbors of Cuddy Mountain v. U.S. Forest Service*, 137 F.3d 1372 (9th Cir. 1998).
- [47] 40 C.F.R. § 1502.14; *see also* *Simmons v. U.S. Army Corps of Engineers*, 120 F.3d 664 (7th Cir. 1997); *Colorado Envtl. Coalition v. Dombek*, 185 F.3d 1162 (10th Cir. 1999).
- [48] Memorandum, Council on Environmental Quality, *Guidance on the Consideration of Past Actions in Cumulative Effects Analysis* (June 24, 2005); *see also* *Selkirk Conservation Alliance v. Forsgren*, 336 F.3d 944 (9th Cir. 2003).
- [49] 40 C.F.R. § 1508.25.
- [50] 40 C.F.R. § 1508.14.
- [51] Oil Shale and Tar Sands Programmatic EIS Information Center, Summary of Public Scoping Comments for the Oil Shale and Tar Sands Resources Leasing Programmatic Environmental Impact Statement, March 2006. http://ostseis.anl.gov/documents/docs/OSTS_PEIS_Scoping_Summary_Report060310.pdf (accessed August 15, 2007).
- [52] 40 C.F.R. § 1508.20.
- [53] 40 C.F.R. §§ 1508.25, 1508.28.
- [54] *See Kleppe v. Sierra Club*, 427 U.S. 390 (1976).
- [55] *Oregon Natural Resources Council v. Marsh*, 832 F.2d 1489 (9th Cir. 1987); *see also* *Thomas v. Peterson*, 753 F.2d 754 (9th Cir. 1985).
- [56] *See Conner v. Burford*, 848 F.2d 1441 (9th Cir. 1988).
- [57] *See Sierra Club v. Peterson*, 717 F.2d 1409 (D.C. Cir. 1983).
- [58] *See Bob Marshall Alliance v. Hodel*, 852 F.2d 1223 (9th Cir. 1988), *cert. denied sub nom. Kohlman v. Bob Marshall Alliance*, 489 U.S. 1066 (1989); *Southern Utah Wilderness Alliance v. Norton*, 457 F.Supp.2d 1253 (D. Utah 2006); *but see* *Park County Resource Council v. United States Dep. of Agriculture*, 817 F.2d 609 (10th Cir. 1987).
- [59] *See Park County Resource Council v. United States Dep. of Agriculture*, 817 F.2d 609 (10th Cir. 1987).
- [60] *See Pennaco Energy, Inc. v. U.S. Dept. of the Interior*, 377 F.3d 1147 (10th Cir. 2004); *Southern Utah Wilderness Alliance v. Norton*, 457 F.Supp.2d 1253 (D. Utah 2006).
- [61] Federal Land Management and Policy Act of 1976, 43 U.S.C. §§ 1701-1785.
- [62] Federal Land Management and Policy Act § 103(c).
- [63] Federal Land Policy and Management Act § 103(h).
- [64] An overview of the public lands and resource values managed by the BLM under FLPMA can be found at <http://www.blm.gov/nhp/facts/index.htm> (accessed August 15, 2007).
- [65] Wilderness Act of 1964, 16 U.S.C. §§ 1131-1136.
- [66] Wilderness Act § 2(c).
- [67] Wilderness Act § 4(b); Wilderness Management, 65 Fed. Reg. 78357 (Dec. 14, 2000).
- [68] Wilderness Act § 4(c).
- [69] Federal Land Management and Policy Act § 603(a).
- [70] Federal Land Management and Policy Act § 603(c).
- [71] Federal Land Policy and Management Act § 201. Brief answers to some common inquiries about the ACEC program are available at http://www.ut.blm.gov/ACEC/acec_FAQ.htm.B (accessed August 15, 2007).
- [72] 43 C.F.R. 1610.7-2 (2006).
- [73] National Wild and Scenic Rivers Act of 1968, 16 U.S.C. §§ 1271-1287.
- [74] 16 U.S.C. § 1272(b).
- [75] 16 U.S.C. § 1272(b)(1-3); 43 C.F.R. § 8351.0-6.
- [76] 16 U.S.C. § 1280.
- [77] Federal Land Management and Policy Act § 202.
- [78] Executive Order 13175, dated Nov. 6, 2000, *Consultation and Coordination With Indian Tribal Governments*, 64 Fed. Reg. 67249 (Nov. 9, 2000).
- [79] Air Pollution Control Act (Clean Air Act), 42 U.S.C. §§ 7401-7671(q).

- [80] Executive Order 13242, dated May 14, 2007, *Cooperation Among Agencies in Protecting the Environment with Respect to Greenhouse Gas Emissions From Motor Vehicles, Nonroad Vehicles, and Nonroad Engines*, 72 Fed.Reg. 27717 (May 16, 2007).
- [81] Clean Air Act § 110.
- [82] Clean Air Act § 108.
- [83] Clean Air Act §§ 171-178.
- [84] Clean Air Act §§ 160-169A.
- [85] Clean Air Act §§ 501-507.
- [86] Clean Air Act § 172(c)(1).
- [87] Clean Air Act §§ 171(3), 173(a)(2).
- [88] Clean Air Act § 112.
- [89] Clean Air Act § 112(d)(2)-(3); Operating permit Program, 57 Fed. Reg. 32250 (July 21, 1992).
- [90] Clean Air Act § 165(d).
- [91] Clean Air Act § 165. If modeling underestimates emissions, the allowable emissions increment will be consumed earlier and fewer hydrocarbons could be produced.
- [92] Clean Air Act § 165(d)(2)(C)(i)-(iii).
- [93] Regional Haze Regulations, 64 Fed. Reg. 35714 (July 1, 1999).
- [94] Bureau of Land Management, *Oil Shale Research, Development and Demonstration Project, White River Mine, Uintah County, Utah*, UT-080-06-280 (April 2007), pp 92-107.
- [95] Bureau of Land Management, *Shell Frontier Oil & Gas Oil Shale Research, Development & Demonstration Tracts: Environmental Assessment*, CO-110-2006-117EA (Nov. 2006), pp 149-151.
- [96] See Bureau of Land Management, *EGL Resources, Inc. Oil Shale Research, Development and Demonstration, Public Review and Comment on the Environmental Assessment* (2006), p 5, 10-25; Bureau of Land Management, CO-110-2006-118-EA *Environmental Assessment: EGL Resources, Inc. Oil Shale Research, Development & Demonstration Tract*, CO-110-2006-117EA (Nov. 2006), pp 121-123.
- [97] Comments of Rick Sprotts, Utah Division of Air Quality, SPE-UGA Oil Shale Conference, May 19, 2006, Salt Lake City, Utah.
- [98] 42 U.S.C. §§ 9601-9675. An overview of CERCLA is available at <http://www.epa.gov/superfund/policy/cercla.htm> (accessed August 15, 2007) .
- [99] Comprehensive Environmental Response, Compensation, and Liability Act § 9601(8).
- [100] *Massachusetts v. EPA*, 127 S.Ct. 1438 (April 2, 2007).
- [101] Global Change Research Act of 1990, 15 U.S.C. §§ 2921-2961.
- [102] Comments of Julio Friedman, Lawrence Livermore National Laboratory, Risks of the Oil Transition, Proceedings of the 26th Annual Oil Shale Symposium, October 16-18, 2006, Golden, CO.
- [103] Endangered Species Act of 1973, 16 U.S.C. §§ 1531-1543.
- [104] U.S. Fish & Wildlife Service, USFWS Threatened and Endangered Species System (TESS). http://ecos.fws.gov/tess_public/StartTESS.do (accessed August 15, 2007).
- [105] Endangered Species Act § 4.
- [106] Endangered Species Act § 3.
- [107] 50 C.F.R. § 17.3 (2006).
- [108] Endangered Species Act § 10.
- [109] Endangered Species Act § 7.
- [110] U.S. Fish & Wildlife Service and National Marine Fisheries Service, *Endangered Species Act Consultation Handbook: Procedures for Conducting Section 7 Consultation and Conference Activities* (March 1998). Also available at <http://www.fws.gov/angered/consultations/s7hndbk/s7hndbk.htm>.
- [111] See *Tennessee Valley Authority v. Hill*, 437 U.S. 153 (1978).
- [112] See 50 C.F.R. § 451.02.

- [113] Migratory Bird Treaty Act of 1918, 16 U.S.C. §§ 701-719c; *see also* 50 C.F.R. § 10.13.
- [114] Bald Eagle Protection Act of 1940, 16 U.S.C. §§ 668-668d.
- [115] Resource Conservation and Recovery Act of 1976, 42 U.S.C. §§ 6901-6992k. An overview of RCRA is available at www.epa.gov/rcraonline/ (accessed August 15, 2007).
- [116] One federal circuit court has suggested as a matter of first impression that solid waste discharges into a water body are potentially subject to regulation under both the CWA and RCRA. *See Pakootas v. Teck Cominco Metals, Ltd.*, 452 F.3d 1066 (9th Cir. 2006).
- [117] Bureau of Land Management, *White River Resource Management Plan*, Department of Interior, 1996.
- [118] Federal Water Pollution Control Act (Clean Water Act), 33 U.S.C. §§ 1251-1387.
- [119] Clean Water Act § 101(a). An overview of the CWA is available at <http://www.epa.gov/watertrain/cwa/index.htm> (accessed August 15, 2007).
- [120] Clean Water Act § 303.
- [121] Clean Water Act § 305(b).
- [122] Clean Water Act § 404.
- [123] 42 U.S.C. §§ 300f–300j-26.
- [124] Safe Water Drinking Act, 42 U.S.C. § 300f(4).
- [125] Safe Water Drinking Act § 300g.
- [126] Safe Water Drinking Act § 300h.
- [127] Colorado River Basin Salinity Control Act, P.L. 93-320, June 24, 1974, 88 Stat. 266.
- [128] U.S. Department of Interior, Bureau of Reclamation, Colorado River Basin Salinity Control Program Overview, available at <http://www.usbr.gov/dataweb/html/crwq.html> (accessed August 15, 2007).
- [129] Congress of the United States, Office of Technology Assessment. An Assessment of Oil Shale Technologies; Office of Technology Assessment: Washington, D.C., June 1980.
- [130] *See* Bureau of Land Management, *Environmental Assessment: Chevron Oil Shale Research, Development & Demonstration*; CO-110-2006-120-EA (Aug. 2006), p 126; Bureau of Land Management, *EGL Resources, Inc. Oil Shale Research, Development and Demonstration, Public Review and Comment on the Environmental Assessment* (2006), p 5, 26-36; Bureau of Land Management, *Environmental Assessment: EGL Resources, Inc. Oil Shale Research, Development & Demonstration Tract*; CO-110-2006-118-EA (Nov. 2006), pp 124-125.
- [131] U.S. Department of Interior, Colorado River Programs and Projects, Oct. 2006. <http://www.doi.gov/issues/colorado.html> (accessed August 15, 2007).
- [132] Pontius, D. *Colorado River Basin Study: Final Report*; Western Water Policy Review Advisory Commission, 1997; pp 10-15.
- [133] *See* McKell, C.M.; Van Epps, G. A Field Test of Processed Oil Shale Reclamation Strategies Designed for Minimal Use of Limited Resources. *Environmental Geochemistry and Health* 1984, 6(2), pp 66-71.
- [134] *See* 43 C.F.R. §§ 3809.11; 3809.31; 3809.400-434; 3809.500; 380.551-573 (2006).



Utah Heavy Oil Program
Institute for Clean and Secure Energy
The University of Utah
155 South 1452 East, Room 380
Salt Lake City, UT 84112