

# Circulation Research

JOURNAL OF THE AMERICAN HEART ASSOCIATION

American Heart  
Association®



*Learn and Live*<sup>SM</sup>

## **The Frequency-Dependent Nature of Blood Pressure Regulation by the Carotid Sinus Studied with an Electric Analog** HOMER R. WARNER

*Circulation Research* 1958, 6:35-40

doi: 10.1161/01.RES.6.1.35

Circulation Research is published by the American Heart Association, 7272 Greenville Avenue, Dallas, TX 75214

Copyright © 1958 American Heart Association. All rights reserved. Print ISSN: 0009-7330. Online ISSN: 1524-4571

The online version of this article, along with updated information and services, is located on the World Wide Web at:

<http://circres.ahajournals.org/content/6/1/35>

Subscriptions: Information about subscribing to *Circulation Research* is online at <http://circres.ahajournals.org/subscriptions/>

Permissions: Permissions & Rights Desk, Lippincott Williams & Wilkins, a division of Wolters Kluwer Health, 351 West Camden Street, Baltimore, MD 21202-2436. Phone: 410-528-4050. Fax: 410-528-8550. E-mail: [journalpermissions@lww.com](mailto:journalpermissions@lww.com)

Reprints: Information about reprints can be found online at <http://www.lww.com/reprints>

# The Frequency-Dependent Nature of Blood Pressure Regulation by the Carotid Sinus Studied with an Electric Analog

By HOMER R. WARNER, M.D., PH.D.

Amplification of carotid sinus activity of a dog is brought about through the use of an electric analog of the carotid sinus applied in parallel with this element of the dog's own pressure regulating system. Sinusoidal excursions in arterial pressure in response to corresponding variations, between fixed limits, in rate of stimulus of one vagus nerve were larger with carotid sinus amplification than without it. Evidence presented supports the concept that because of the delay in the response of arteriolar smooth muscle, effective buffering of sudden variations in arterial pressure cannot be accomplished by variations in resistance, but can be through variations in flow.

THE carotid sinus constitutes but one part of a dog's blood pressure control system. To date, studies which have aimed at defining the role played by the carotid sinus as an integral part of this regulating system have been limited to observations on the effects of removal of one or both carotid sinuses or the effects of surgical or pharmacologic interruption of nervous pathways in other parts of the blood pressure regulating system. As yet data regarding the effect on the integrated regulation of arterial pressure of varying quantitatively the characteristics of the carotid sinus function are not available. In the present study an electric analog of the carotid sinus, whose parameters could be readily varied, has been employed in an attempt to obtain such data. The use of this device has made possible amplification of the effects of carotid sinus activity, thus emphasizing both the advantages and the limitations of this organ as an element of the blood-pressure regulating system.

## MATERIALS

It has been established<sup>1,2</sup> that the frequency of

---

From the Department of Physiology, Latter-Day Saints Hospital and University of Utah, Salt Lake City, Utah.

Supported by grant H2073, U. S. Public Health Service.

Received for publication August 12, 1957.

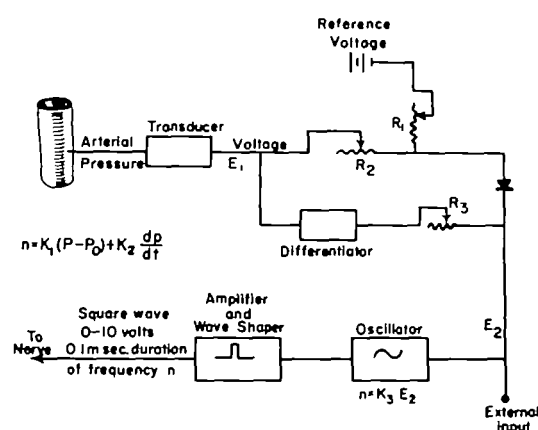

FIG. 1. Diagram of an electronic analog of the carotid sinus and the equation which describes its function.

action potentials recorded from a carotid sinus nerve is a function of carotid artery pressure and its time derivative. Also, it has been shown<sup>3</sup> that electric stimulation of a carotid sinus nerve produces a fall in pressure that is a direct function of the frequency of the stimulus. On the basis of these facts an electric circuit<sup>4</sup> has been devised to simulate the regulatory function of the carotid sinus.

A diagram of this carotid sinus analog and the equation which describes its performance are shown in figure 1. In the equation,  $n$  is the frequency of action potentials at a point on the carotid sinus nerve,  $p$  is the pressure in the carotid artery,  $p_0$  is the minimum static pressure capable of eliciting

---

\*Made by Engineering Specialty Co., Salt Lake City, Utah.

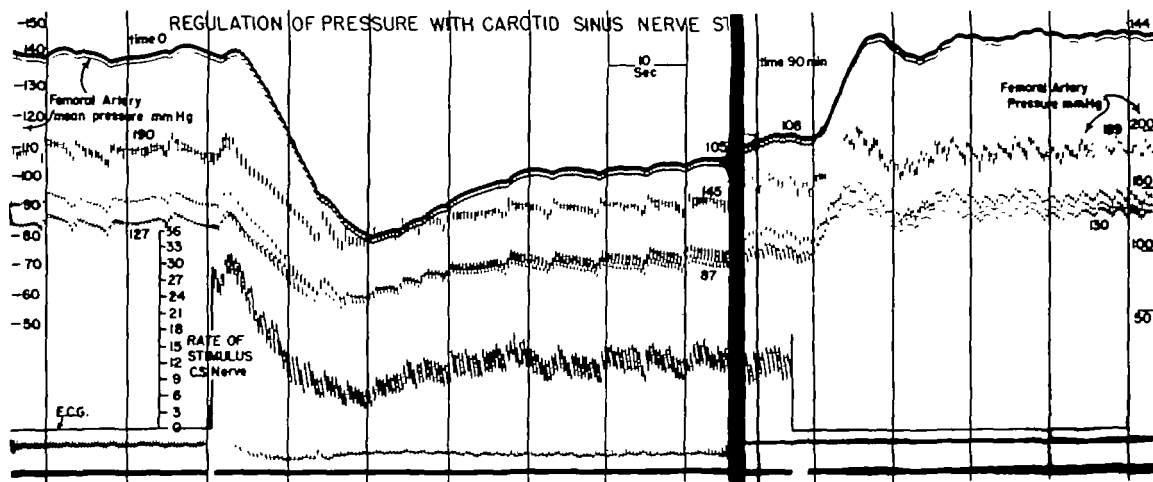

FIG. 2. *Left section.* Direct recording of mean and pulsatile pressure in femoral artery of a dog showing the result of applying the output from the carotid sinus analog to the intact right carotid sinus nerve. Recorded rate of stimulus varies directly with pressure. *Right section.* Effect of discontinuing stimulation 90 min. later.

action potentials, and  $dp/dt$  is the rate of change of pressure in the artery. The coefficients  $k_1$  and  $k_2$  are considered constants for the purpose of this study.

The voltage labeled  $E_2$  in the diagram is derived from three sources: (1) the output voltage ( $k_1p$ ) from a pressure transducer connected to a needle in a carotid artery of a dog, (2) a negative reference voltage ( $k_1P_0$ ), and (3) a voltage ( $k_2dp/dt$ ) proportional to the derivative of the strain gage output.  $E_2$  modulates the frequency of an oscillator whose output goes to a wave shaper where each cycle is converted to a square wave of 8 V. amplitude and 0.1 msec. duration. These pulses constitute the stimulus that is applied by means of a bipolar electrode to a carotid sinus nerve of the dog.

From inspection of the diagram it may be noted that a servo loop has been established through the dog which should act to resist variations in arterial pressure from a level determined, in part, by the setting of  $R_1$ . A rise in arterial pressure will result in an increase in the frequency of stimulation of the carotid sinus nerve. The magnitude of the increase in stimulus frequency for a given rise in pressure will be determined by the setting of  $R_2$ . This increased rate of stimulus will tend to return the pressure to the initial level. The influence of  $R_3$  on the performance of the system will be discussed later in the paper. Also, it will be shown that the other element in the feedback loop, which is a property of the dog, the relationship between the change in the rate of stimulus and the resulting change in arterial pressure, requires a phase as well as an amplitude factor for its description.

#### PROCEDURE

Mongrel dogs were anesthetized with intravenous Nembutal (30 mg./Kg.). Mean and pulsatile arterial pressures were recorded from the right and left femoral arteries respectively using Stat-ham P23 D pressure transducers, a photokymographic recorder, and optimally damped galvanometers. A similar transducer connected to a needle in a carotid artery supplied the signal voltage for the carotid sinus analog.

Through a skin incision high on one side of the neck, the region of the carotid sinus was carefully exposed by blunt dissection. A small plastic spring-loaded "clothes-pin-like" structure supporting a bipolar electrode in the form of two pointed steel contacts was secured to the carotid sinus nerve about 5 mm. from its origin in the carotid sinus. Repeated attempts at electrode placement were sometimes necessary in order to achieve a satisfactory fall in blood pressure in response to stimulation. The carotid sinus region on the opposite side of the neck was not disturbed. Both vagus nerves were exposed low in the neck in such a way that similar stimulating electrodes could be placed on them at the appropriate time in the experiment. The vagi were not severed. Whenever two nerves were being stimulated at the same time it was found necessary to employ an isolation transformer to prevent cross-stimulation between the nerves.

#### RESULTS

In figure 2 are shown events that take place when the stimulus from the carotid sinus ana-

log is suddenly applied to a carotid sinus nerve. Since the reference voltage ( $P_0$ ) was set to a level corresponding to a pressure below that existing in the artery just prior to application of the stimulus, closing the circuit led to a fall in pressure. With the fall in pressure there was a decrease in the rate of stimulus. As the rate of stimulus reached a minimum the pressure began to rise until a steady state was established. Forty seconds after the onset of stimulation a pressure level was obtained which was held within narrow limits for the next 90 min. These records are omitted in the figure. On discontinuing the stimulation (right section of fig. 2) the pressure oscillated once and then returned to essentially the control level.

This recording illustrates two important properties of the carotid sinus mechanism: (1) The carotid sinus nerve does not "fatigue" with continued stimulation and (2) there is a delay of 10 to 15 sec. between the time of onset of stimulation of the carotid sinus nerve and the time of maximum depressor response to this stimulation. It appears from experiments such as this that the carotid sinus mechanism is capable of playing a role in the long-term regulation of arterial pressure.

We next wished to evaluate its possible role in compensating for transient changes in arterial pressure.

In the experiment from which the recording shown at the top of figure 3 was made, the intact right vagus nerve was stimulated for 30 sec. at a constant rate. When the stimulation was discontinued at the time so marked on the record, the arterial pressure underwent a slow oscillation. If the carotid sinus mechanism were operating to damp out this oscillation in pressure, the amplification of carotid sinus function brought about by applying the electric analog to the dog should be expected to further diminish the amplitude of the oscillation. The recording shown at the bottom of figure 3 shows little if any change in amplitude of the pressure oscillation following cessation of vagal stimulation when this maneuver is repeated with the carotid sinus analog

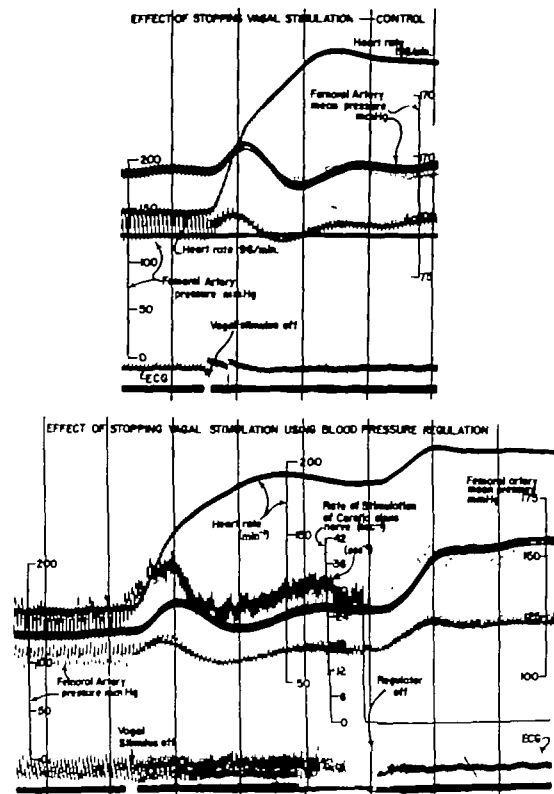

FIG. 3. *Upper.* Control effect of stopping stimulation of right vagus nerve on femoral pressure and heart rate. *Lower.* Same with carotid sinus effect amplified by electric analog. Oscillation in pressure following cessation of vagal stimulation, essentially uninfluenced by the analog regulator. Note rise in pressure when analog regulator was turned off.

in the system. Observations of this sort and similar results obtained following other maneuvers designed to elicit transient disturbances in arterial pressure suggested that the carotid sinus mechanism might be inadequate to regulate against rapid pressure disturbances in the animal because of the long delay in the depressor response to carotid sinus nerve stimulation.

A study of the time-dependency of blood pressure regulation was next undertaken. This was accomplished by varying arterial pressure sinusoidally at different frequencies and following the extent to which the dog's pressure regulating system could control the pressure fluctuations. From a low frequency function generator, sinusoidal variations in voltage between fixed limits but at various

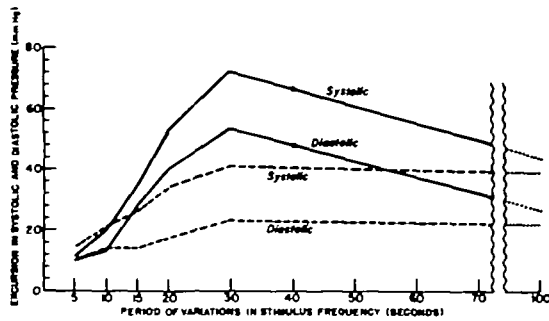

FIG. 4. Plot showing excursions in arterial pressure resulting from sinusoidal variation in the rate of stimulus of the left vagus nerve between fixed limits. *Solid lines*, with regulator; *dashed lines*, without regulator.

frequencies were fed into a circuit similar to the one shown in figure 1 at the point marked "external input." The stimulus frequency from this circuit, which varied in proportion to this input voltage, was then applied to one vagus nerve. This provided a reproducible drive for varying arterial pressure.

The pressure response to a right vagal stimulus whose rate of stimulation varied from 0 to 5/sec. over each cycle was recorded. These cycles of varying stimulus frequency were made to occur at periods of 5, 10, 15, 20, 30, and 100 sec. The maximum excursion in pressure occurred when the cycle length of the pressure variations was 30 sec. The procedure was repeated with the carotid sinus analog in the system. The excursions in pres-

sure were actually larger with this amplification of carotid sinus function than without it. This is emphasized in figure 4 which shows a comparison of the excursions in pressure with and without the electronic "regulator" in the system.

Failure of the carotid sinus mechanism to effectively diminish the amplitude of oscillations in pressure occurring at certain frequencies is the result of the delay between onset of stimulation of carotid sinus nerve and the resulting depressor response. This delay is due to the sluggish response of the smooth muscle of arterioles to nervous stimulation.<sup>4, 5</sup> It was decided to test the performance of the feedback circuit when it was made to act on a part of the system which exerts its primary effect on the heart rather than on resistance to flow. This was done by applying the stimulus from the carotid sinus analog to a vagus nerve instead of a carotid sinus nerve.

During the center portion of the record in figure 5 both vagi were stimulated. The rate of stimulation of the left vagus varied sinusoidally with a period of 20 sec. The stimulus applied to the right vagus was the output from the carotid sinus analog. Note that in the center portion of this record when the right vagus is being stimulated the excursions in pressure are much smaller than at either end when the analog was not in the system. Effective damping was achieved at all frequencies tested when the regulation of pres-

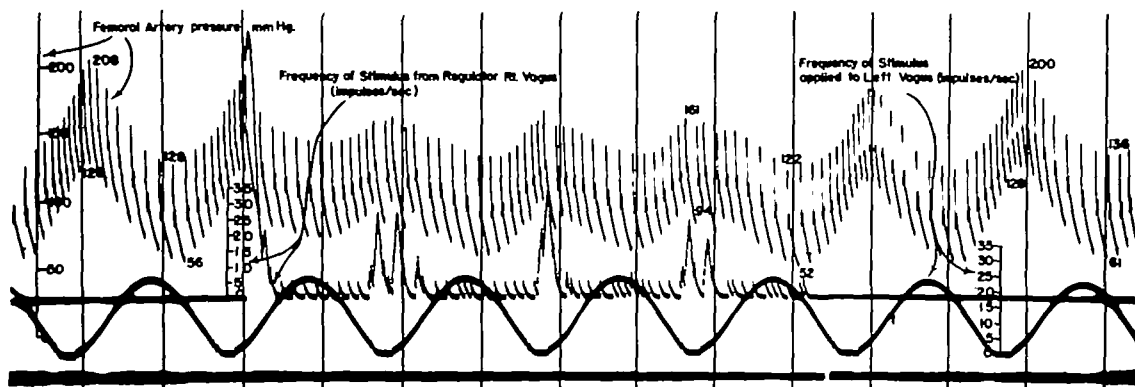

FIG. 5. Record of femoral artery pressure showing effective buffering of pressure variations when output from carotid sinus analog stimulated right vagus nerve in center portion of record.

sure was accomplished through vagal stimulation.

In figure 6 the ratios of the excursions in pressure with the analog to those without it are plotted against the period of the sinusoidal variations in pressure. A ratio of 1:0 would indicate no effect due to the analog. Further explanation of this plot is given in the discussion.

The extent to which the analog is sensitive to the time-derivative of pressure was varied by adjusting  $R3$ . Varying  $R3$  over wide limits had no detectable effect on the performance of the analog as a buffer against variations in pressure described above.

#### DISCUSSION

Guyton and Harris<sup>6</sup> attempted to evaluate the frequency-dependent nature of blood pressure regulation in the dog using periodic variations in blood volume as a means of changing pressure. These authors found that when the period of the variations in volume was 25 sec., the resulting fluctuations in arterial pressure were larger with the carotid sinus mechanism functioning than after carotid sinus denervation. They came to the conclusion that the failure of the carotid sinus mechanism to diminish fluctuations in pressure of certain frequencies is a result of the time-lag in the depressor response to carotid sinus nerve stimulation.

Theoretically, such a delay in a servo system will convert negative feedback to positive when the period of the variations in input is twice the response time of the system. Further, if the over-all gain around the loop is greater than one, the system will be unstable and the oscillations will become progressively larger. Our failure to observe this instability even with gain in the analog far in excess of that in the carotid sinus itself is attributed to the alinear depressor response of the animal to increasing frequency of carotid sinus nerve stimulation.

Since mean arterial pressure is determined by just two variables, flow and resistance, any mechanism which regulates pressure must do so through its effect on one or both of these.

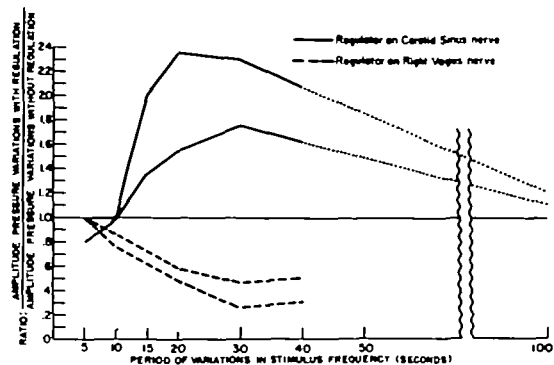

FIG. 6. Plots showing influence of regulator on induced pressure excursions. *Solid lines*, regulator on carotid sinus nerve; *dashed lines*, regulator on right vagus nerve.

A mechanism which regulates pressure primarily through control of resistance involves contraction of smooth muscle, chiefly in arterioles, and thus would be expected to manifest to a varying degree the undesirable frequency-dependent characteristics as a regulator that have been demonstrated here for the carotid sinus mechanism. This prediction is made on the basis that the delay in the depressor response to carotid sinus nerve stimulation most certainly is the result of the slow response of the arteriolar smooth muscle since there is no significant delay in the response of sympathetic efferents to carotid sinus nerve stimulation.<sup>7</sup>

In contrast to this, it has been demonstrated here (fig. 6) that because variations in flow may be brought about rapidly in response to variations in frequency of stimulation of a vagus nerve,<sup>8</sup> a feedback mechanism with this as its efferent pathway is capable of acting as an effective buffer against sudden changes in pressure. It is postulated that in any pressure-regulating system the effector organ is the link which determines the phase of the feedback of that system at a given frequency. (Positive feedback is shown above the line of unity in figure 6 and negative below.) The other elements in the system merely contribute to the gain of the system.

When a feedback signal proportional to the time-rate of change of the variable being regulated is present in a servo system, it usually

serves to stabilize the system by "anticipating" changes. It should not be surprising that the  $dp/dt$  element in the carotid sinus mechanism apparently fails to play such a role since  $dp/dt$  goes from large positive to large negative values with each heart cycle, completely masking the rate of any variations in mean pressure occurring at frequencies to which the effector organ could respond. However, recent studies<sup>9</sup> do suggest that this element of the carotid sinus mechanism is important in determining the steady-state level of mean pressure.

#### SUMMARY

An electronic analog of the carotid sinus was used as a means of amplifying the effects of carotid sinus activity. Because of the delay in the response of arteriolar smooth muscle to carotid sinus nerve stimulation, amplification of carotid sinus activity aggravates rather than diminishes arterial pressure variations at certain frequencies. Evidence is presented in support of the concept that the phase of any feedback loop in the integrated system which regulates arterial pressure is determined by the time-lag in the response of its effector organ.

#### SUMMARIO IN INTERLINGUA

Un analogo electronic del sinus carotic es-seva usate pro amplificar le effectos del activitate del sinus carotic. A causa del retardo in le responsa de lisie musculos arteriolar al stimulation nervose del sinus carotic, le amplification del activitate del sinus carotic resulta in un exacerbation plus tosto que in un diminution del variationes in le pression

arterial a certe frequentias. Es presentate datos in supporto del conception que le phase de omne ansa de feedback in le systema integrate que determina le pression arterial depende del retardo in le responsa de su organo effectori.

#### REFERENCES

1. BRONK, D. W. AND STELLA, G.: Afferent impulses in the carotid sinus nerve. *J. Cell. & Comp. Physiol.* **1**: 113, 1932.
2. LANDGREN, S.: On the excitation mechanism of the carotid baroreceptors. *Acta physiol. scandinav.* **26**: 1, 1952.
3. DOUGLAS, W. W. AND RITCHIE, J. M.: Cardiovascular reflexes produced by excitation of non-medullated afferents in the vagus, carotid sinus and aortic nerves. *J. Physiol.* **134**: 167, 1957.
4. FURCHGOTT, R. F.: The pharmacology of vascular smooth muscle. *Pharm. Rev.* **7**: 183, 1955.
5. LEONARD, E.: Alteration of contractile response of artery strips by a potassium-free solution, cardiac glycosides and changes in stimulation frequency. *Am. J. Physiol.* **189**: 185, 1957.
6. GUYTON, A. C., BATSON, H. M., SMITH, C. M., AND ARMSTRONG, G. G.: Method for studying competence of the body's blood pressure regulatory mechanisms and effect of pressoreceptor denervation. *Am. J. Physiol.* **164**: 360, 1951.
7. BRONK, D. W., FERGUSON, I. D., AND SOLANDT, D. Y.: Inhibition of cardiac accelerator impulses by the carotid sinus. *Proc. Soc. Exper. Biol. & Med.* **31**: 579, 1933.
8. WANG, S. C. AND BORISON, H. L.: An analysis of the carotid sinus cardiovascular reflex mechanism. *Am. J. Physiol.* **150**: 712, 1947.
9. EAD, H. W., GREEN, J. H., AND NEIL, E.: A comparison of the effects of pulsatile and non-pulsatile blood flow through the carotid sinus on the reflexogenic activity of the sinus baroreceptors in the cat. *J. Physiol.* **118**: 509, 1952.