

LONG-TERM CLINICAL IMPLICATIONS OF GASTRIC BYPASS SURGERY
SPECIFIC TO CARDIORESPIRATORY FITNESS, PREGNANCY-RELATED
BIRTH WEIGHT AND AGE-RELATED MORTALITY

by

Ted D. Adams

A dissertation submitted to the faculty of
The University of Utah
in partial fulfillment of the requirements for the degree of

Doctor of Philosophy

in

Public Health

Department of Family and Preventive Medicine

The University of Utah

August 2014

Copyright © Ted D. Adams 2014

All Rights Reserved

The University of Utah Graduate School

STATEMENT OF DISSERTATION APPROVAL

The dissertation of _____ **Ted D. Adams** _____

has been approved by the following supervisory committee members:

_____ **Mia Hashibe** _____, Chair **6/12/2014**
Date Approved

_____ **Jessica L.J. Greenwood** _____, Member **6/12/2014**
Date Approved

_____ **Jaewhan Kim** _____, Member **6/12/2014**
Date Approved

_____ **David Taylor** _____, Member **6/13/2014**
Date Approved

_____ **Steven C. Hunt** _____, Member **6/11/2014**
Date Approved

and by _____ **Steven Alder** _____, Chair/Dean of

the Department/College/School of _____ **Public Health** _____

and by David B. Kieda, Dean of The Graduate School.

ABSTRACT

Severe obesity (BMI ≥ 35) is increasing at a 2 to 3 times greater rate than Class I obesity (BMI 30-34). Successful intervention for the severely obese is primarily limited to bariatric surgery, with over 200,000 procedures performed yearly in the U.S. Despite an increasing use of bariatric surgery, long-term outcome studies following this intervention are very limited, and identification of clinical predictors of bariatric surgery durability is lacking. To address these important knowledge gaps, the proposed study will draw upon data obtained from long-term prospective gastric bypass study ($n=1156$) and from a gastric bypass patient registry ($n=13,500$; 1979-2012). These studies will explore 3 specific clinical questions in patients who have had the most popular bariatric surgical procedure, the Roux-en-Y gastric bypass (RYGB).

- Does cardiorespiratory fitness (CRF) predict 2- and 6-year weight loss following RYGB?
- Does RYGB influence the birth weight of babies born to women post-RYGB surgery?
- Does the age at which RYGB surgery is performed influence longer term mortality outcomes?

The following aims will be pursued. Aim 1 will test the association baseline and 2-year CRF with weight loss at 2- and 6-years, respectively. In addition, how well change in CRF from 2- to 6-years predicts weight regain 2- to 6-years will be tested. For

analyses, data collected as part of a 6-year prospective study ($n=1156$) exploring long-term morbidity following RYGB surgery will be used. Aim 2 will test the association between RYGB surgery and the birth weight of babies born to mothers before and following their RYGB surgery. Data from a large RYGB registry ($n=13,500$) and from matched nonbariatric surgery control mothers and their babies will be used to identify birth weights using birth certificates from the Utah Population Database. Aim 3 will test the association between the age of patients when undergoing RYGB surgery and subsequent long-term mortality. Mortality data obtained from the National Death Index bureau on post-RYGB surgical patients ($n=7925$) and matched, nonoperated, severely obese Utah drivers license applicants ($n=7925$), will be used for data analyses. Results for these investigations promise to contribute to the clinical understanding of the long-term health effects following RYGB surgery.

This dissertation is dedicated to Dr. Steven C. Hunt, a great mentor and friend, and to Mr. and Mrs. Jon and Karen Huntsman for their generous support of the Intermountain Research and Medical Foundation, Lori Piscopo, Director, who approved the Huntsman Fellowship that made this doctoral work possible.

TABLE OF CONTENTS

ABSTRACT.....	iii
LIST OF TABLES.....	viii
LIST OF FIGURES.....	x
ACKNOWLEDGEMENTS.....	xi
CHAPTERS	
1. INTRODUCTION	1
Background.....	1
References.....	7
2. THE ASSOCIATION BETWEEN CARDIORESPIRATORY FITNESS AND LONGER TERM WEIGHT LOSS AND WEIGHT REGAIN FOLLOWING GASTRIC BYPASS SURGERY	12
Background.....	12
Methods.....	13
Results.....	18
Discussion.....	22
References.....	29
3. ASSOCIATION OF GASTRIC BYPASS ON GESTATIONAL AGE AND WEIGHT OF CHILDREN BORN BEFORE AND FOLLOWING GASTRIC BYPASS SURGERY	33
Background.....	33
Methods.....	34
Results.....	42
Discussion.....	49
References.....	55

4. HISTORY ASSOCIATION OF PATIENT’S AGE AT GASTRIC BYPASS SURGERY WITH LONG-TERM ALL-CAUSE AND CAUSE-SPECIFIC MORTALITY	60
Background	60
Methods.....	62
Results.....	64
Discussion	71
References.....	76
5. CONCLUSION.....	79
Conclusions.....	79
References.....	83

LIST OF TABLES

Table	Page
2.1 Baseline, 2- and 6-Year Characteristics of Roux-en-Y Gastric Bypass Patients.....	19
2.2 Beta Coefficient, Standard Error, and P Value for Change in Weight from Baseline to 2 Years in Relation to Total Treadmill Time Measured at Baseline, and for Change in Weight from 2 to 6 Years in Relation to Total Treadmill Time Measured at Year 2.....	20
2.3 Beta Coefficient, Standard Error, and P Value for Change in Weight from 2 to 6 Years in Relation to Change in Total Treadmill Time (With and Without Relative Representation by Fat Free Mass).....	21
3.1 Maternal and Pregnancy-Related Characteristics for Groups 1-3.....	43
3.2 Group 1: Birth Weight and Gestational Age of Roux-en-Y Gastric Bypass Mother's Neonate Born Closest to Before Surgery and First Neonate Born After Surgery Compared to Matched Nonsurgery Mother's Pregnancies Matched to the RYGB Mother's Pregnancy Closest to Before Surgery and to First Pregnancy Following Surgery.....	45
3.3 Group 2: Birth Weight and Gestational Age of Roux-en-Y Gastric Bypass Mother's Neonate Born Closest to Following Surgery Compared to Matched Nonsurgery Mother's Neonate Matched to the Gastric Bypass Mother's Neonate Born Closest to Following Surgery.....	46
3.4 Group 3: Birth Weight and Gestational Age of All Neonates Born Before Surgery and All Neonates Born Following Surgery to All Roux-en-Y Gastric Bypass Mothers (no matching to nonoperated mothers or neonates).....	47
4.1 Descriptive Characteristics of Post Roux-en-Y Gastric Bypass Surgery Patients and Nonoperated Matched Subjects.....	65
4.2 Distribution of Deaths and Death Rates per 10,000 Person-Years, According to Study Group and Stratified by Age Categories.....	66

4.3	Adjusted Hazard Ratios* for Death in the Gastric Bypass Surgery Groups as Compared with the Nonsurgery Group by Age-stratification.....	68
-----	---	----

LIST OF FIGURES

Figure	Page
1.1. Description of Roux-en-Y gastric bypass surgical procedure.....	4
2.1 Scatter Plot of Change in Weight from 2 to 6 Years in Patients Following Roux-en-Y Gastric Bypass Surgery Associated with Change in Total Treadmill Time from Year 2 to Year 6.....	23
2.2 Scatter Plot of Change in Weight from 2 to 6 Years in Patients Following Roux-en-Y Gastric Bypass Surgery Associated with Change in Total Treadmill Time Divided by Fat Free Mass from Year 2 to Year 6.....	23
3.1 Roux-en-Y Gastric Bypass and Matched Nonsurgical Mothers and Neonates.....	35
3.2 Matching Schemes Used for Groups.....	37
4.1 Hazard Ratios (HRs) for All-Cause Mortality by Age.....	69
4.2 Hazard Ratios (HRs) for Cardiovascular Disease Mortality by Age.....	69
4.3 Hazard Ratios (HRs) for Cancer Mortality by Age.....	70
4.4 Hazard Ratios (HRs) for External Cause Mortality by Age.....	70

ACKNOWLEDGEMENTS

The author wishes to acknowledge Dr. Mia Hashibe, chair of the dissertation committee, for her kind assistance and encouragement, and to express thanks to the committee members, Drs. Greenwood, Kim, Taylor, and Hunt, for their time and devotion. Expressed appreciation is given to the faculty and administrative staff of the Division of Public Health, including Drs. Steve Alder and Jim VanDerslice, whose leadership and support were invaluable. Acknowledgement and thanks are also given to the board and staff members of the Intermountain Research and Medical Foundation, Lori Piscopo, Director, whose approval of the Huntsman Fellowship made possible this doctoral work. Thanks are expressed to Mr. and Mrs. Jon and Karen Huntsman for their generous support of the Intermountain LiVe Well Center, Salt Lake City. Also, appreciation is extended to the staff (including Dr. Frank Yanowitz, a long-time colleague) of the LiVe Well Center, Salt Lake City, who supported the author in this doctoral effort. Dr. Scott F. Hansen is the Medical Director and Melisa Wright is the Department Director of the LiVe Well Center. Finally, the author also expresses his love and appreciation to his wife, Suzanne Swan Adams, for her untiring support.

Research support for the studies reported in this dissertation was provided by a grant (DK-55006) from the National Institute of Diabetes and Digestive and Kidney Disease and a grant (M01-RR00064) from the National Center for Research Resources. In addition, the author was the recipient of the Huntsman Fellowship, Intermountain

Research and Medical Foundation, and the Intermountain LiVe Well Center, Salt Lake City.

CHAPTER 1

INTRODUCTION

Background

Escalating Dilemma

1-in-3 U.S. adults are estimated to be obese (BMI ≥ 30 kg/m²). [1] Although concerning, a more alarming statistic is the fact that severe obesity (BMI ≥ 35 kg/m²) is increasing at a 2- to-3 times greater rate than Class I obesity (BMI 30-34 kg/m²), [2-5] and that the more traditional approaches to weight loss (lifestyle counseling, weight management, and pharmacological therapy) are generally insufficient for treating severe obesity. [6-8] Even intense medical therapy used in recent randomized control trials has demonstrated only 5% weight loss in severely obese participants at 1 to 2 years follow-up. [9-11] Health-related consequences of severe obesity include an increased rate of death [12-14] and increased risk for multiple comorbidities [15] such as type 2 diabetes mellitus (T2DM), hypertension, hyperlipidemia, increased inflammatory state, sleep apnea, fatty liver disease, and cardiac dysfunction. [16-23] Severe obesity has also been linked with impaired quality of life [24] and increased health care costs. [25]

Addressing the Dilemma

To date, the only available medical intervention that has demonstrated substantial short- and long-term effects on weight loss in the severely obese population is bariatric surgery. [26, 27] Both prospectively controlled cohort studies[6, 28] and randomized control trials[9, 10] have reported percentages of initial weight loss among severely obese patients undergoing gastric bypass or sleeve gastrectomy procedures to be 25-35% at 1- to 2 years follow-up and 25-28% at 6- to 10-years following surgery. In addition, limited long-term studies have demonstrated clinically relevant improvements in obesity-related conditions such as T2DM remission and improved blood pressure and lipids, with some degree of recurrence of these comorbidities over time.[6, 28] Cohort studies have also noted a decreased mortality in patients who have undergone bariatric surgery, especially from myocardial infarction, diabetes, and cancer-related deaths.[27, 29, 30]

Filling the Critical Gap

Although successful intervention for the severely obese is primarily limited to bariatric surgery, long-term outcome studies following bariatric surgery are very limited.[31] The National Institutes of Health (NHLBI and NIDDK) recently convened a workshop (Bethesda, Maryland, May 2013) to explore what is known and not known about long-term outcomes of bariatric surgery. Consensus of the international-based participants was that there exists important clinical knowledge gaps related to bariatric surgery due to the sparseness of long-term follow-up research studies. Examples of limited outcomes research include the assessment of microvascular and macrovascular events in patients with T2DM and criteria to better predict which bariatric patients are

more or less likely to successfully lose and maintain weight loss (i.e., identifying factors contributing to the long-term durability of bariatric surgery). To address additional important knowledge gaps, the proposed study will explore 3 specific clinical aspects related to the long-term effects of voluntary weight loss in patients who have undergone the Roux-en-Y gastric bypass (RYGB) surgical procedure.

Bariatric Surgery

Treating severe obesity. Although bariatric (weight loss) surgery has been used to treat severe obesity for almost 50 years, the increase in popularity has increased only in the past 20 years, with a seven-fold increase between 1996 and 2002 (from 3.5 to 24.0 per 100,000 population).[32] The dramatic rise in popularity of bariatric surgery is largely the result of increasing severe obesity, new surgical techniques such as laparoscopy, increased safety, favorable weight loss, and improved obesity-related comorbidities.[32-38] Recently updated guidelines for the treatment of overweight and obesity have been published. With respect to bariatric surgical treatment, adults must have a BMI ≥ 40 kg/m² or ≥ 35 kg/m² with obesity-related comorbid conditions. In addition, potential surgical candidates should be “motivated to lose weight” and demonstrated that they have not been able to successfully (or adequately) respond to traditional lifestyle/behavioral treatment with or without medication therapy.[39]

Bariatric surgical procedures. Current procedures include the Roux-en-Y gastric bypass (RYGB), adjustable gastric banding, biliopancreatic diversion with duodenal switch, and a vertical sleeve gastrectomy. Of these operations, the RYGB is considered to be the most popular bariatric surgical procedure globally[40] and in the U.S.,[41, 42]

with a nine-fold increase in the 1990s.[34, 38] This operation, now performed almost exclusively laparoscopically, reroutes the normal gastrointestinal tract (Figure 1.1a) as the stomach and the entire first segment of the small intestine, the duodenum, are bypassed (Figure 1.1b). A small proximal pouch of the stomach (15-20 mL) is formed to receive ingested foods. As a result of the anatomical alterations resulting from RYGB surgery, this procedure is generally recognized as a restrictive and partially malabsorptive operation. In addition to the weight loss effects produced by the restrictive and malabsorptive properties of the RYGB procedure, a considerable degree of research is ongoing to understand additional physiologic-related mechanisms that are likely to be associated with the surgery such as hormonal and neuronal alterations,[43] and less

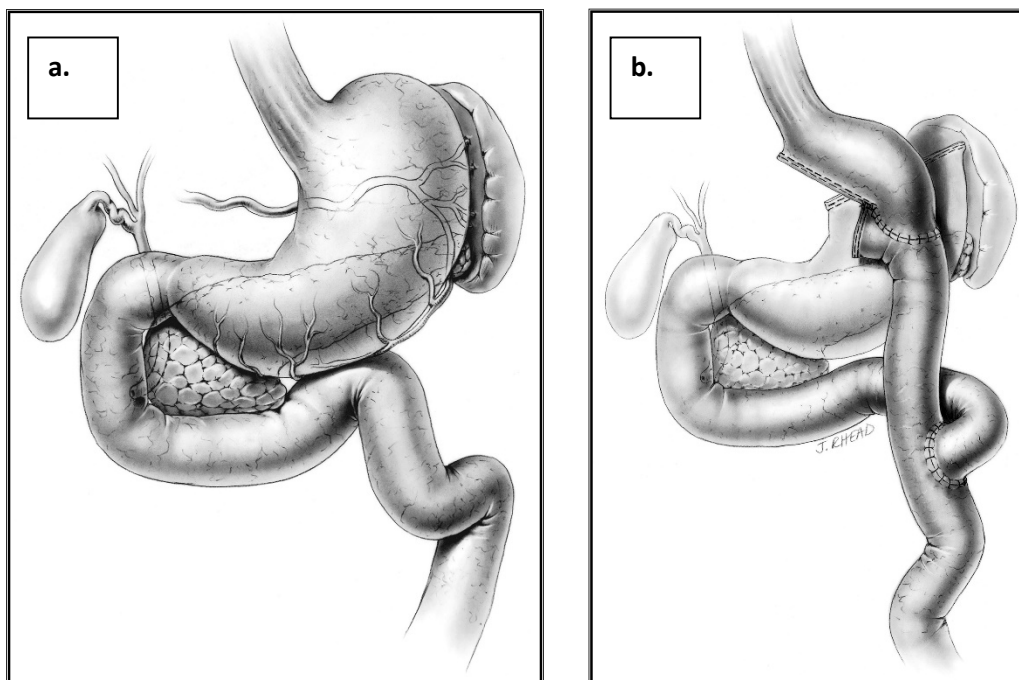

Figure 1.1 Description of Roux-en-Y gastric bypass surgical procedure. a. Depiction of normal gastrointestinal tract. b. Illustration of the anatomical arrangement following Roux-en-Y gastric bypass. Note the complete bypass of the stomach and the duodenum.

related to the effects of weight loss.

Clinical outcomes from bariatric surgery. Our Utah group has prospectively followed post-RYGB patients as well as 2 severely obese control groups (see “Study subjects and study design” section). This study represents the largest and longest followed cohort of RYGB patients. Figure 1.2 illustrates the change in BMI from baseline to follow-up at years 2 and 6, with projected 10-year follow-up BMI based upon data obtained at 2 and 6 years. The longest prospective study related to bariatric surgery is the Swedish Obesity Subjects (SOS) study. Initiated in 1987, this study enrolled 2010 bariatric surgical patients and matched severely obese patients ($n=2037$).[44] The bariatric surgical patients underwent 3 different procedures: the vertical banded gastroplasty (VBG) (68% of patients); the gastric banding (19%); and RYGB (13%). Unfortunately, the VBG is no longer used as a bariatric surgical procedure. The SOS study research team has reported on a number of clinical and cost outcomes related to bariatric surgery.[28, 44-46] At their 15-year follow-up, the reported percent mean weight loss was $13 \pm 14\%$ for the gastric banding group, $18 \pm 11\%$ for the VBG, and $27 \pm 12\%$ for the RYGB group. These results support the generally accepted finding that RYGB patients have greater initial and extended weight loss when compared to the gastric banding procedure.

Short-term (2 years postsurgery), RYGB surgery has resulted in substantial improvement in major comorbidities.[47-49] Perhaps the most dramatic clinical outcome following RYGB surgery has been the rapid remission of type 2 diabetes mellitus (T2DM). Where T2DM has generally been considered an irreversible chronic disease without hope of remission,[50] remarkably, 80% of type 2 diabetic patients who have RYGB surgery have complete remission (i.e., a return to normal glucose and hemoglobin

A1c values and no further use of diabetes medication).[51-54] Further, the remission of diabetes is rapid, within 2 days to 2 weeks after RYGB – long before significant weight loss.[52, 55] This compelling finding suggests that the rapidity of diabetes remission with malabsorptive surgeries such as RYGB occurs through mechanisms independent of whole-body obesity reduction.[50, 55, 56] As a result, attention has shifted from fat loss to other mechanisms such as insulinotropic gut hormones (particularly the incretin GLP-1) to explain this nearly miraculous diabetes remission in RYGB patients.[57-60] Our Utah group reported a diabetes remission rate at the 2-year exam for diabetics having RYGB surgery of 75% (95% CI, 63,87) and 62% (95% CI, 49-75) at the 6-year exam. The majority of bariatric surgery studies have reported on weight loss and related clinical outcomes over relatively short time periods, with longer term investigations (i.e., 6 years or longer) lacking.[61] As a result, significant opportunity exists to exam long-term clinical outcomes following bariatric surgery. This study will take full advantage of data from a RYGB registry (1979 to present; $n=13,500$) and of data from a 6-year prospective RYGB study (2001-2007; $n=1156$).

Conclusion

In conclusion, to address these important knowledge gaps, the proposed study will draw upon data obtained from a large, long-term prospective gastric bypass study ($n=1156$) and from a gastric bypass patient registry ($n=13,500$; 1979-2012). These studies will explore 3 specific clinical questions related to the long-term effects of voluntary weight loss in patients who have had the most popular U.S. bariatric surgical procedure, the Roux-en-Y gastric bypass (RYGB).

- Does cardiorespiratory fitness (CRF) predict 2- and 6-year weight loss following RYGB surgery?
- Does RYGB surgery influence the birth weight of babies born to women post-RYGB surgery?
- Does the age at which RYGB surgery is performed influence longer term mortality outcomes?

The 3 aims of this study will address the NIH-identified research gap and will increase the understanding of the predictability and durability of this surgical therapy as well the role of bariatric surgery on perinatal outcomes.

References

1. Ogden, C.L., et al., *Prevalence of overweight and obesity in the United States, 1999-2004*. JAMA, 2006. **295**(13): p. 1549-55.
2. Sturm, R. and A. Hattori, *Morbid obesity rates continue to rise rapidly in the United States*. Int J Obes (Lond), 2012.
3. Sturm, R., *Increases in morbid obesity in the USA: 2000-2005*. Public Health, 2007. **121**(7): p. 492-6.
4. Sturm, R., *Increases in clinically severe obesity in the United States, 1986-2000*. Arch Intern Med, 2003. **163**(18): p. 2146-8.
5. Freedman, D.S., et al., *Trends and correlates of class 3 obesity in the United States from 1990 through 2000*. JAMA, 2002. **288**(14): p. 1758-61.
6. Adams, T.D., et al., *Health benefits of gastric bypass surgery after 6 years*. JAMA, 2012. **308**(11): p. 1122-31.
7. Li, Z., et al., *Meta-analysis: pharmacologic treatment of obesity*. Ann Intern Med, 2005. **142**(7): p. 532-46.
8. Yanovski, S.Z. and J.A. Yanovski, *Long-term drug treatment for obesity: A systematic and clinical review*. JAMA, 2014. **311**(1): p. 74-86.

9. Schauer, P.R., et al., *Bariatric surgery versus intensive medical therapy in obese patients with diabetes*. N Engl J Med, 2012. **366**(17): p. 1567-76.
10. Mingrone, G., et al., *Bariatric surgery versus conventional medical therapy for type 2 diabetes*. N Engl J Med, 2012. **366**(17): p. 1577-85.
11. Look, A.R.G., et al., *Cardiovascular effects of intensive lifestyle intervention in type 2 diabetes*. NEJM, 2013. **369**(2): p. 145-54.
12. Adams, K.F., et al., *Overweight, obesity, and mortality in a large prospective cohort of persons 50 to 71 years old*. N Engl J Med, 2006. **355**(8): p. 763-78.
13. McTigue, K., et al., *Mortality and cardiac and vascular outcomes in extremely obese women*. JAMA, 2006. **296**(1): p. 79-86.
14. Flegal, K.M., et al., *Association of all-cause mortality with overweight and obesity using standard body mass index categories: a systematic review and meta-analysis*. JAMA, 2013. **309**(1): p. 71-82.
15. Must, A., et al., *The disease burden associated with overweight and obesity*. JAMA, 1999. **282**(16): p. 1523-9.
16. Leibson, C.L., et al., *Temporal trends in BMI among adults with diabetes*. Diabetes Care, 2001. **24**(9): p. 1584-9.
17. Stamler, R., et al., *Weight and blood pressure. Findings in hypertension screening of 1 million Americans*. JAMA, 1978. **240**(15): p. 1607-10.
18. Mathieu, P., et al., *Visceral obesity: the link among inflammation, hypertension, and cardiovascular disease*. Hypertension, 2009. **53**(4): p. 577-84.
19. Klein, S., T. Wadden, and H.J. Sugerman, *AGA technical review on obesity*. Gastroenterology, 2002. **123**(3): p. 882-932.
20. Kleiner, D.E., et al., *Design and validation of a histological scoring system for nonalcoholic fatty liver disease*. Hepatology, 2005. **41**(6): p. 1313-21.
21. Poirier, P., et al., *Bariatric Surgery and Cardiovascular Risk Factors: A Scientific Statement From the American Heart Association*. Circulation, 2011. **123**(15): p. 1683-1701.
22. Gregg, E.W., et al., *The relative contributions of different levels of overweight and obesity to increased prevalence of diabetes in the United States: 1976-2004*. Preventive Medicine, 2007. **45**(5): p. 348-52.
23. Kasper, E.K., R.H. Hruban, and K.L. Baughman, *Cariomyopathy of obesity: a*

- clinicopathologic evaluation of 43 obese patients with heart failure. Am J Cardiol*, 1992. **70**(9): p. 921-24.
24. Sarwer, D.B., M. Lavery, and J.C. Spitzer, *A review of the relationships between extreme obesity, quality of life, and sexual function. Obes Surg*, 2012. **22**(4): p. 668-76.
 25. Arterburn, D.E., M.L. Maciejewski, and J. Tsevat, *Impact of morbid obesity on medical expenditures in adults. Int J Obes (Lond)*, 2005. **29**(3): p. 334-9.
 26. Flum, D.R., et al., *Perioperative safety in the longitudinal assessment of bariatric surgery. N Engl J Med*, 2009. **361**(5): p. 445-54.
 27. Sjostrom, L., et al., *Effects of bariatric surgery on mortality in Swedish obese subjects. N Engl J Med*, 2007. **357**(8): p. 741-52.
 28. Sjostrom, L., et al., *Lifestyle, diabetes, and cardiovascular risk factors 10 years after bariatric surgery. N Engl J Med*, 2004. **351**(26): p. 2683-93.
 29. Adams, T.D., et al., *Long-term mortality after gastric bypass surgery. N Engl J Med*, 2007. **357**(8): p. 753-61.
 30. Christou, N.V., et al., *Surgery decreases long-term mortality, morbidity, and health care use in morbidly obese patients. Ann Surg*, 2004. **240**(3): p. 416-23.
 31. Kushner, R.F. and C.A. Noble, *Long-term outcome of bariatric surgery: an interim analysis. Mayo Clin Proc*, 2006. **81**(10 Suppl): p. S46-51.
 32. Davis, M.M., et al., *National trends in bariatric surgery, 1996-2002. Arch Surg*, 2006. **141**(1): p. 71-4; discussion 75.
 33. Buchwald, H. and D.M. Oien, *Metabolic/Bariatric surgery worldwide 2008. Obes Surg*, 2009. **19**(12): p. 1605-11.
 34. Trus, T.L., G.D. Pope, and S.R. Finlayson, *National trends in utilization and outcomes of bariatric surgery. Surg Endosc*, 2005. **19**(5): p. 616-20.
 35. Robinson, M.K., *Surgical treatment of obesity--weighing the facts. N Engl J Med*, 2009. **361**(5): p. 520-1.
 36. Steinbrook, R., *Surgery for severe obesity. N Engl J Med*, 2004. **350**(11): p. 1075-9.
 37. *The ASBS Consensus Conference on the State of Bariatric Surgery and Morbid Obesity: Health Implications for Patients, Health Professionals and Third-Party Payors. in ASBS Consensus Conference. 2004. Georgetown University,*

Washington, D.C.

38. Hensrud, D.D., *Extreme obesity: a new medical crisis in the United States*. Mayo Clin Proc, 2006. **81**(10): p. S5-10.
39. Jensen, M.D., et al., *AHA/ACC/TOS Guideline of rhte management of overweight and obesity in adults/*. J Am Coll Cardiol, 2013.
40. Buchwald, H. and D.M. Oien, *Metabolic/bariatric surgery worldwide 2011*. Obes Surg, 2013. doi: **10.1007/s11695-012-0864-0**.
41. Livingston, E.H., *Procedure incidence and in-hospital complication rates of bariatric surgery in the United States*. Am J Surg, 2004. **188**(2): p. 105-10.
42. Santry, H.P., D.L. Gillen, and D.S. Lauderdale, *Trends in bariatric surgical procedures*. JAMA, 2005. **294**(15): p. 1909-17.
43. Stefater, M.A., et al., *All bariatric surgeries are not created equal: insights form mechanistic comparisons*. Endocrine Reviews, 2012. **33**(4): p. 595-622.
44. Sjostrom, L., *Review of the key results from the Swedish Obesity Subjects (SOS) trial - a prospective controlled intervention study of bariatric surgery*. J Intern Med, 2013. **273**(3): p. 219-234.
45. Sjostrom, L., et al., *Bariatric surgery and long-term cardiovascular events*. JAMA, 2012. **307**(1): p. 56-65.
46. Sjostrom, L., et al., *Effects of bariatric surgery on cancer incidence in obese patients in Sweden (Swedish Obese Subjects Study): a prospective, controlled intervention trial*. Lancet Oncol, 2009. **10**(7): p. 653-62.
47. Gloy, V.L., et al., *Bariatric surgery versus nonsurgical treatment for obesity: a systematic review and meta-analysis of randomised controlled trials*. BMJ, 2013. **347**: p. f5934.
48. Buchwald, H., et al., *Bariatric surgery: A systematic review and meta-analysis*. JAMA, 2004. **292**(14): p. 1724-1737.
49. Adams, T.D., et al., *Health outcomes of gastric bypass patients compared to nonsurgical, nonintervened severely obese*. Obesity (Silver Spring), 2010. **18**(1): p. 121-30.
50. Cummings, D.E. and D.R. Flum, *Gastrointestinal surgery as a treatment for diabetes*. JAMA, 2008. **299**(3): p. 341-3.
51. Schauer, P.R., et al., *Effect of laparoscopic Roux-en Y gastric bypass on type 2*

- diabetes mellitus*. Ann Surg, 2003. **238**(4): p. 467-84; discussion 84-5.
52. Thaler, J.P. and D.E. Cummings, *Minireview: Hormonal and metabolic mechanisms of diabetes remission after gastrointestinal surgery*. Endocrinology, 2009. **150**(6): p. 2518-25.
 53. Torquati, A., et al., *Is Roux-en-Y gastric bypass surgery the most effective treatment for type 2 diabetes mellitus in morbidly obese patients?* J Gastrointest Surg, 2005. **9**(8): p. 1112-6; discussion 1117-8.
 54. Wittgrove, A.C. and G.W. Clark, *Laparoscopic gastric bypass, Roux-en-Y- 500 patients: technique and results, with 3-60 month follow-up*. Obes Surg, 2000. **10**(3): p. 233-9.
 55. Hickey, M.S., et al., *A new paradigm for type 2 diabetes mellitus: could it be a disease of the foregut?* Ann Surg, 1998. **227**(5): p. 637-43.
 56. Vetter, M.L., et al., *Narrative review: effect of bariatric surgery on type 2 diabetes mellitus*. Ann Intern Med, 2009. **150**(2): p. 94-103.
 57. Bose, M., et al., *Weight loss and incretin responsiveness improve glucose control independently after gastric bypass surgery*. J Diabetes, 2010. **2**(1): p. 47-55.
 58. Kashyap, S.R., et al., *Acute effects of gastric bypass versus gastric restrictive surgery on beta-cell function and insulinotropic hormones in severely obese patients with type 2 diabetes*. Int J Obes (Lond), 2010. **34**(3): p. 462-71.
 59. Laferrere, B., et al., *Effect of weight loss by gastric bypass surgery versus hypocaloric diet on glucose and incretin levels in patients with type 2 diabetes*. J Clin Endocrinol Metab, 2008. **93**(7): p. 2479-85.
 60. Laferrere, B., et al., *Incretin levels and effect are markedly enhanced 1 month after Roux-en-Y gastric bypass surgery in obese patients with type 2 diabetes*. Diabetes Care, 2007. **30**(7): p. 1709-16.
 61. Lefevre, M. and N. Aronson, *Special report: the relationship between weight loss and changes in morbidity following bariatric surgery for morbid obesity*. TEC Assessment Program, Blue Cross and Blue Shield Association, 2003. **18**(9): p. 1-25.

CHAPTER 2

THE ASSOCIATION BETWEEN CARDIORESPIRATORY FITNESS AND LONGER TERM WEIGHT LOSS AND WEIGHT REGAIN FOLLOWING GASTRIC BYPASS SURGERY

Background

Pursuant to the increased interest in bariatric surgery by public and medical communities,[1-3] research efforts to identify clinical factors that might predict short- and long-term durability following surgery (i.e., weight loss maintenance) have been pursued.[4-7] Nonsurgical, conventional-focused weight loss interventions have demonstrated participation in physical activity predicts short-term weight loss success [8, 9] and especially long-term weight loss maintenance.[10] To date, studies relating participation in physical activity before bariatric surgery and/or following bariatric surgery in relation to postsurgical weight loss outcomes have primarily consisted of observational studies using self-reported physical activity recall questionnaire data and a few studies using accelerometers with questionnaires.[11-15] Further, these studies have generally assessed physical activity engagement for less than 1 year. The reported general consensus from these studies is that physical activity increases following bariatric surgery and that involvement in physical activity is associated with weight loss. However, there appears to be no reported data relating to long-term changes (i.e., greater than 2 years) in

measured cardiorespiratory fitness, a marker for participation in physical activity, following bariatric surgery.

The purpose of this study was to examine the association between long-term changes in measured cardiorespiratory fitness and weight loss among patients who participated in Roux-en-Y gastric bypass surgery, for the purpose of understanding whether or not changes in cardiorespiratory fitness predict weight loss at 2 years and/or subsequent weight gain at 6 years follow-up. These data were obtained as part of an ongoing Utah-based prospective study of gastric bypass patients.

Methods

Study Subjects

Subjects for this study were drawn from a prospective controlled study focused on the outcomes of Roux-en-Y gastric bypass (RYGB) surgery, whose previous methods and results related to baseline, 2 and 6 years follow-up have been previously published.[16, 17] The RYGB surgical patients ($n=418$), operated on by a partnership of 3 surgeons (Rocky Mountain Associated Physicians, Inc.), were the focus of this study. Prior to surgery, these patients had a reported body mass index (BMI) of greater or equal to 40 kg/m^2 or greater than or equal to 35 kg/m^2 and 2 comorbidities, which primarily included cardiovascular, sleep apnea, uncontrolled type 2 diabetes, or weight-induced physical problems that were interfering with daily functioning. Exclusion criteria for all study participants included: previous gastric surgery for weight loss; gastric or duodenal ulcers in the previous 6 months; active cancer within the past 5 years (except for nonmelanoma skin cancer); myocardial infarction in the previous 6 months; and history of alcohol or narcotic abuse. Prior to RYGB surgery, each patient underwent an overnight

baseline examination at the University of Utah Center for Clinical and Translational Science (CCTS) or a daytime only examination at our center's outpatient clinic as previously described.[17] Of the total 418 RYGB surgical patients, a total of 306 (73%) were examined at the CCTS for the overnight study. All participants were invited to return for follow-up examinations at 2 and 6 years at the CCTS or outpatient clinic. Because clinical tests relevant to this study were only performed at the CCTS, only data obtained from RYGB participants examined at this facility were analyzed for this report.

Study Examinations

This study protocol was approved by the University of Utah Institutional Review Board, and prior to participation, signed consent was obtained from all participants. All participants were asked to complete a variety of clinical and lifestyle questionnaires and undergo anthropometric, biochemistry, and cardiopulmonary testing.[17] Tests specific to this study included measurement of height, weight, percent body fat, resting metabolic rate, and cardiorespiratory fitness (exercise treadmill test). Height was measured using a Harpenden anthropometer (Holtain, Ltd., Crymych, United Kingdom) to the nearest centimeter. Weight was measured with a Scaletonix scale (model 5100) (Scaletonix Corporation, Wheaton, IL). The scale has an 800-lb capacity and weighing accuracy of 0.1 kg. Body mass index (BMI) was calculated as body weight divided by height squared (kg/m^2). The resting metabolic rate (RMR) was measured in the CCTS prior to the subject getting out of bed the morning following an overnight stay and a 12-hour fast. The RMR was measured using open-circuit indirect calorimetry, using a portable metabolic cart (TrueMax 2400; Parvo Medics, Salt Lake City, UT) with a plastic

ventilated hood. Prior to data collection, the metabolic system was calibrated and patients were made familiar with the ventilation hood. Participants were asked to remain motionless and encouraged not to sleep during the procedure. Once steady state was obtained, the test was continued for at least 10 min. Percent body fat was determined from the measurement of resistance and reactance to electrical current using bioelectrical impedance equipment (RJL Systems Analyzer; Quantum II, Clinton, MI). Because all patients had spent the night in the CCTS and had not eaten food (regular hydration was allowed), consumed alcohol, or exercised, all required pretesting criteria for impedance analysis were met. All participants were asked to lie in a supine position for at least 5 min before the examination.

The graded exercise treadmill test was conducted in the afternoon when patients arrived at the CCTS. Prior to the exercise test, a Mason-Likar ECG-lead placement[18] was applied to patients to monitor resting and exercise 12-lead electrocardiogram (ECG). Prior to the exercise test, supine and standing blood pressures and heart rates were recorded. The stress testing system was comprised of a Marquette Max One System and a Marquette 2000 motor-driven treadmill (Marquette Corporation, Milwaukee, WI). The electrocardiogram was monitored continuously during exercise by a trained exercise technician and a physician was in close proximity during testing. A modified Bruce treadmill protocol was used for all tests. The treadmill speed and grade were as follows: 2 min at stage 1: 1.0 mph, 0% grade; stage 2: 1.7 mph, 0% grade (3 min); stage 3: 1.7 mph, 5% grade (3 min); stage 4: 1.7 mph, 10% grade (3 min); stage 5: 2.5 mph, 12% grade (3 min); stage 6: 3.4 mph, 14% grade (3 min); and stage 7: 4.2 mph, 16% grade (3 min). The estimated workload of each exercise stage based on the treadmill speed and grade[19]

was 1.8, 2.3, 3.5, 4.6, 7.1, 10.2, and 13.5 METs, respectively, where 1 MET = 3.5 ml O₂ uptake per kg body mass per min. Participants were encouraged to exercise using the handrails only for balance (not to support their body weight during the test) to 80% of their age-predicted maximum heart rate (220—age) at which point the test was discontinued. Other indications for stopping the test included abnormal ECG, heart rate or blood pressure responses, participant malaise, equipment failure, or at the discretion of the supervising physician.[19] The subject's perceived exertion (6–20 Borg point scale) was recorded at the end of each stage. Blood pressure and heart rate were recorded during the last 30 seconds of each stage of exercise and at immediate, 3 and 6 min recovery. Total exercise time in min was also recorded. Exercise testing was conducted by an exercise test technologist with a cardiologist in close proximity and was completed in accordance with published clinical guidelines.[19] While study investigators opted for submaximal testing (using a modified Bruce protocol) to avoid potential harm or discomfort that may be incurred during maximal exercise testing in patients whose functional capacity is limited by deconditioning or existing disease,[17] the baseline testing results demonstrated that from a clinical point-of-view, the patients tolerated well the submaximal test. As a result, for the 2- and 6-year cardiorespiratory tests, participants were asked to exercise to their full capacity, or maximal effort. Finally, the income categories were ascertained using a 1 to 6 scale: 1, less than \$9,999; 2, \$10,000 to \$29,000; 3, \$30,000 to \$49,000; 4, \$50,000 to \$69,000; 5, \$70,000 to \$99,000; and 6, greater than or equal to \$100,000.

Statistical Analysis

Using patient data obtained before and following Roux-en-Y gastric bypass surgery, multiple linear regression was used for statistical analyses. The 3 specific aims of this study focused on whether cardiorespiratory fitness (CRF), represented by total treadmill time, measured at baseline and 2 years predicted change in body weight at 2 and 6 years, respectively (Aims 1 and 2), and whether or not change in body weight from 2 to 6 years (i.e., 6-year weight minus 2-year weight) was associated with 2- to 6-year change in CRF (i.e., 6-year CRF minus 2-year CRF) (Aim 3). Testing Aims 1 and 2 included regressing change in body weight from baseline to 2 years (dependent variable) with CRF measured at baseline (independent variable), as well as associating weight change from 2 to 6 years with CRF measured at 2 years. These analyses were adjusted for baseline weight (Aim 1 regression analysis) and for year 2 weight (Aim 2 regression analysis). Change in body weight from 2 to 6 years was then regressed with change in CRF from 2 to 6 years (Aim 3). For Aim 3 regression analysis, the covariates of weight at 2 years, resting energy expenditure (REE) measured at 2 years, treadmill time at 2 years, and the change of REE from 2 to 6 years (i.e., 6-year REE minus 2-year REE) were added to the model. Finally, in an attempt to represent CRF relative to total muscle mass, this regression analysis scheme was repeated as previously described replacing the Aim 3 variable of change in total treadmill time from 2 to 6 years with the variable with 6-year total treadmill time divided by fat-free mass measured at year 6 minus the 2-year total treadmill time divided by fat-free mass obtained at year 2. Comparison of mean differences for 2 and 6 years for specific variables (age, weight, income, total treadmill time, fat free mass, and resting energy expenditure) was analyzed using standard 2 mean

Student *t*-test. Significance level was set at $p < 0.05$ and the study data were analyzed using Stata, Version 13.1.

Results

A descriptive representation of the subjects and variables used for this study are presented in Table 2.1. Of the 306 Roux-en-Y gastric bypass (RYGB) patients who participated in the overnight examination at the CCTS, 295 (96%) underwent a baseline exercise treadmill test, with 273 of these participants having resting metabolic rate measured. These 295 RYGB were on average 42.5 years of age (± 10.7 years), 133.9 kilograms (± 25.9 kilograms), and 85% were female. As expected, weight at the 2-year examination decreased to a mean of 87.8 kilograms (± 21.8 kilograms), representing a 34.4% reduction in initial body weight. Body weight measured at the 6-year examination increased by 5.2% (7.0 kilograms, $p=0.003$) compared to the 2-year body weight (mean 6-year examination equal to 94.8 ± 23.0 kilograms). The total treadmill time at baseline was equal to 576.0 ± 197.5 seconds and represented 80% of the patient's predicted maximal heart rate. As detailed in the methods section, for the 2- and 6-year examinations, participants were encouraged to exercise to their maximal effort. The change in maximal total treadmill time from 2 to 6 years was 37.4 seconds, or a 4.4% decrease ($p=0.029$). The resting energy expenditure (REE) from baseline to the 2-year examination decreased by 430.9 kcal/day (19.8% decrease) but from 2 to 6 years, the change in REE was not significantly different ($p=0.957$). While the reduction in fat free mass (FFM) from baseline to 2 years was 14.3 kilograms (23% reduction; $p<0.0001$), the slight change in fat free mass from 2 to 6 years (1.8 kilogram increase) was not

Table 2.1. Baseline, 2- and 6-Year Characteristics of Roux-en-Y Gastric Bypass Patients.

Study Variables	Baseline		2 years		6-Years	
	No. of Patients	Mean (SD)	No. of Patients	Mean (SD)	No. of Patients	Mean (SD)
Female sex, %	295	85	217	82	156	83
Age, y	295	42.5 (10.7)	217	46.7 (10.1)	156	51.1 (10.2)†
Income category (scale 1-6)	285	3.60 (1.27)	215	3.80 (1.34)	155	3.81 (1.23)
Weight, kg	295	133.9 (25.9)	217	87.8 (21.8)	156	94.8 (23.0)***
Fat free mass, kg	293	62.3 (12.7)	216	48.0 (14.1)	152	49.8 (13.9)
Total treadmill time, seconds	295	576.0 (197.5)*	217	851.4 (158.0)**	156	814.0 (169.3)** ††
Resting energy expenditure, Kcal/day	273	2181.3 (403.3)	208	1750.4 (325.6)	144	1748.5 (327.7)

*Baseline total treadmill time related to submaximal cardiorespiratory test (i.e., 80% of predicted maximal heart rate).

**Total treadmill time related to maximal cardiorespiratory test.

† $p < 0.0001$ for 2 year results compared to 6 year results.

*** $p < 0.01$ for 2 year results compared to 6 year results.

†† $p < 0.05$ for 2 year results compared to 6 year results.

significantly different ($p=0.23$). With reference to 2- and 6-year CRF measurement, at 2 years, 221 RYGB surgical patients returned to the CCTS for overnight testing (72% follow-up compared to baseline) and 217 (98%) underwent an exercise treadmill test. At year 6, 161 RYGB patients returned to the CCTS (73% follow-up compared to year 2; 53% follow-up compared to baseline), and 156 (97%) participated in an exercise treadmill test.

Results related to Aims 1 and 2, whether or not cardiorespiratory fitness (i.e., total treadmill time) measured at baseline and at year 2 predicted weight change from baseline to year 2 and from year 2 to year 6, respectively are detailed in Table 2.2. Once change in weight from baseline to year 2 in association with baseline treadmill time was adjusted for baseline weight, baseline total treadmill time no longer predicted weight change measured at year 2 ($p=0.945$). Similarly, year 2 total treadmill time in association with weight change from 2 to 6 years, when adjusted for year 2 weight, was not significant ($p=0.385$). Analyses for Aim 3, whether or not change in CRF (total treadmill time) from 2 to 6 years predicted 2- to 6-year weight change, are detailed in Table 2.3. The progressive inclusion of additional covariates in statistical models 1 through 3 of Table

Table 2.2. Beta Coefficient, Standard Error, and P Value for Change in Weight from Baseline to 2 years in Relation to Total Treadmill Time Measured at Baseline, and for Change in Weight from 2 to 6 Years in Relation to Total Treadmill Time Measured at Year 2. Adjustments Included Within Models 1 and 2.

Statistical Models	Covariates	Change in Weight 2 from Baseline to 2 years (Dependent Variable) in Reference Total Treadmill Time Measured at Baseline (Independent Variable)			Covariates	Change in Weight from 2 to 6 Years (Dependent Variable) in Reference Total Treadmill Time Measured at 2 years (Independent Variable)		
		Beta Co-efficient	Standard Error	P Value		Beta Co-efficient	Standard Error	P Value
#1	Total Treadmill Time Measured at Baseline, min	0.0097	0.0046	0.038	Total Treadmill Measured at 2 years, min/kg	0.0036	.00052	0.509
#2	Total Treadmill Time Measured at Baseline, min	-0.0003	0.0041	0.945	Total Treadmill Measured at 2 years, min/kg	0.0050	0.0058	0.385
	Baseline Weight, kg	-0.3240	0.0317	<0.0001	2 Year Weight, kg	0.03221	0.0414	0.437

Table 2.3. Beta Coefficient, Standard Error, and P Value for Change in Weight From 2 to 6 Years in Relation to Change in Total Treadmill Time (With and Without Relative Representation by Fat Free Mass). Progressive Adjustments Included Within Models 1 to 3.

Statistical Models	Covariates	Change in Weight 2 to 6 Years (Dependent Variable) in Reference to Total Treadmill Time (Independent Variable)			Covariates	Change in Weight 2 to 6 Years (Dependent Variable) in Reference to Total Treadmill Time/Fat Free Mass (Independent Variable)		
		Beta Co-efficient	Standard Error	P Value		Beta Co-efficient	Standard Error	P Value
#1	Change in Total Treadmill Time from 2 to 6 Years, min	-0.022	0.007	0.001	Change in Total Treadmill Time/Fat Free Mass from 2 to 6 Years, min/kg	-1.579	0.223	<0.0001
#2	Change in Total Treadmill Time from 2 to 6 Years, min	-0.022	0.007	0.002	Change in Total Treadmill Time/Fat Free Mass from 2 to 6 Years, min/kg	-1.524	0.225	<0.0001
	Female	1.005	2.249	0.45	Female	-0.511	1.198	0.797
	Age	-0.162	0.084	0.055	Age	-0.111	0.759	0.144
	Income	-0.605	0.697	0.387	Income	-0.424	0.626	0.499
#3	Total Treadmill Time, min	-0.002	0.008	0.002	Total Treadmill Time/Fat Free Mass, min/kg	-1.468	0.226	<0.0001
	Female	0.118	2.920	0.04	Female	-0.833	2.515	0.741
	Age	-0.146	0.091	-1.60	Age	-0.110	0.783	0.163
	Income	-0.471	0.674	0.486	Income	0.009	0.585	0.988
	2 Year Weight, kg	-0.092	0.735	0.214	2 Year Weight, kg	-0.124	0.062	0.048
	2 Year REE*, Kcal	0.006	0.005	0.198	2 Year REE*, Kcal	0.011	0.004	0.017
	2 Year Total Treadmill Time, min	-0.013	0.008	0.084	2 Year Total Treadmill Time, min	-0.020	0.006	0.002
	Change in REE from 2 to 6 Years, Kcal	0.021	0.004	<0.0001	Change in REE from 2 to 6 Years, Kcal	0.021	0.004	<0.0001

*REE = Resting energy expenditure.

2.3, respectively, demonstrated that change in total treadmill time from 2 to 6 years, relative and not relative to fat free mass, significantly predicted the change in weight change from year 2 to year 6 (p values ranging from 0.001 to 0.002 for total treadmill time and <0.0001 for treadmill time relative to fat free mass). In addition, treadmill time measured at year 2 and change in resting energy expenditure from 2 to 6 years were also significant for predicting change in 2- to 6-year weight. Figures 2.1 and 2.2 are graphical representations of the unadjusted association between 2- to 6-year weight change and change in CRF 2 to 6 years (Figure 2.1) and unadjusted association between 2- to 6-year weight change and change in total treadmill time/fat free mass 2 to 6 years (Figure 2.2). The respective R^2 values for Tables 2.1 and 2.2 were 0.08 and 0.38, respectively.

Discussion

To our knowledge, this study represents the first long-term study (i.e., 2 years or greater) tracking change in weight and cardiorespiratory fitness following Roux-en-Y gastric bypass surgery. These results demonstrated that although submaximal and maximal cardiorespiratory fitness as measured by total treadmill time at baseline and at 2 years, respectively, did not predict weight change from baseline to 2 years or weight change from 2 to 6 years when adjusted for baseline and 2-year weight, respectively, change in cardiorespiratory fitness from 2 to 6 years was significantly associated with 2- to 6-year weight change. Further, when total treadmill time was divided by change in fat free mass from 2 to 6 years, change in weight from 2 to 6 years was even more significantly associated with change in cardiorespiratory fitness.

Typically, the “gold standard” for measuring cardiorespiratory fitness (CRF) is



Figure 2.1: Scatter Plot of Change in Weight from 2 to 6 Years in Patients Following Roux-en-Y Gastric Bypass Surgery Associated with Change in Total Treadmill Time from Year 2 to Year 6.

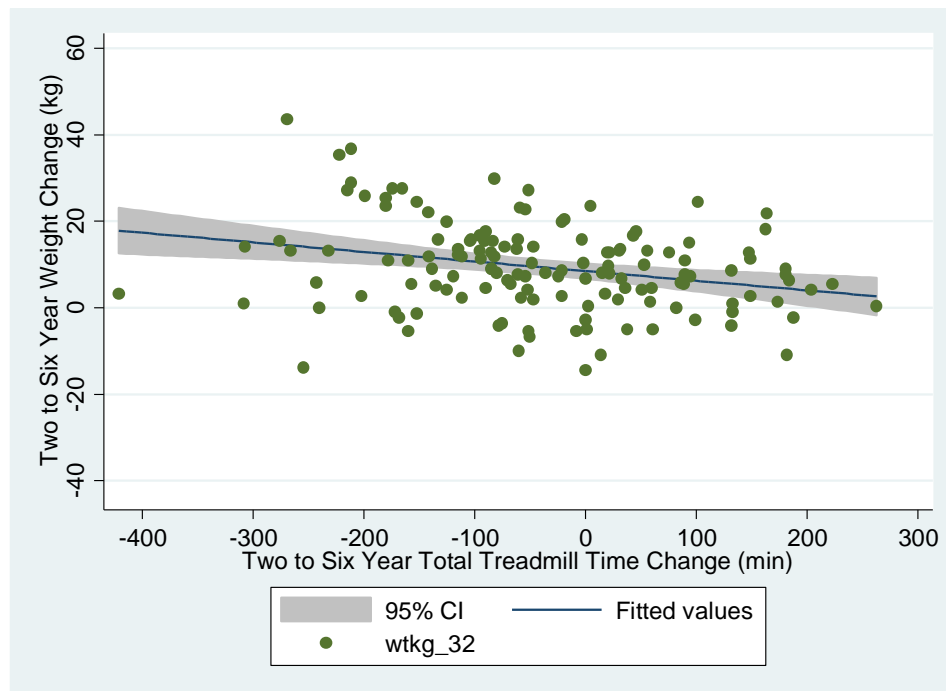

Figure 2.2 Scatter Plot of Change in Weight from 2 to 6 Years in Patients Following Roux-en-Y Gastric Bypass Surgery Associated with Change in Total Treadmill Time Divided by Fat Free Mass from Year 2 to Year 6.

based on the measurement of respiratory gas exchange using indirect calorimetry analysis during maximal exertion. [20, 21] This study opted to assess CRF with a submaximal treadmill exercise test (using a modified Bruce protocol) as part of the baseline examination and then employ maximal exercise testing (same modified Bruce protocol) for years 2 and 6 examinations. This type of submaximal and maximal exercise testing protocols have been highly correlated with laboratory measures of maximal cardiorespiratory fitness (CRF) that use respiratory gas analysis.[20, 22] In an attempt to understand CRF in relation to the lifestyle-related aspects of physical movement, previously published reviews have carefully delineated the difference between physical fitness and cardiorespiratory fitness.[23-26] In a more general sense, the term “physical fitness” has reference to a “variety of characteristics” that are found within the broader categories of cardiorespiratory fitness; body composition, strength, and flexibility.[26] From this description, fitness has been further identified as one’s capability of engaging in moderate to vigorous physical activity during the course of one’s life.[26, 27] Within this context, one would naturally conclude that the opportunity to increase physical fitness (or cardiorespiratory fitness) and its associated health benefits would require a person to engage in repeated bouts of physical activity.[23, 28]

However, for patients who undergo RYGB surgery, postsurgery changes in CRF (i.e., increased total treadmill time) may likely be due to factors in addition to their increased participation in physical activity. The improved total treadmill time following RYGB surgery may also be linked to the very significant and sustained weight loss (i.e., greater than or equal to 50 kilograms), improved musculoskeletal function, and enhanced energy efficiency at any given submaximal work load performed during the exercise

treadmill test. In fact, in this Utah study, although baseline fitness predicted change in weight loss from baseline to year 2, this prediction was no longer significant once adjustment was made for baseline weight. The very large percentage of weight loss (35% of initial weight from baseline to 2 years) simply overwhelmed all other possible weight loss prediction-related factors.

Investigators of the long-term Swedish Obesity Subjects (SOS) study have reported that obese women who have had bariatric surgery report a lower 2- and 6-year incidence of knee and ankle joint pain (OR, 0.51 to 0.71).[29] In addition, although the SOS follow-up approach for participation in physical activity was limited to self-reported questionnaire, over a 2- to 10-year follow-up period, the postbariatric surgical patients did report an increase in their participation in physical activity.[30, 31] Based upon these findings, the authors surmise that just as physical inactivity “contributes” to the development of obesity,[32] the obesity state may further promote physical inactivity,[33] creating a downward spiraling cycle. Further, bariatric surgery may well break this cycle,[33] resulting in the postoperative patient’s ability to move with less challenge (i.e., pain and discomfort) and to engage in being physically active (leisure or otherwise) with greater energy efficiency. This logic may suggest that RYGB patients participating in this Utah study were able to significantly extend their total treadmill time because of improved energy efficiency (i.e., reduced total fat mass) at specific submaximal workloads.

The findings from this Utah study, that changes in total treadmill time from year 2 to 6 predicted change in weight during the same follow-up period, may support the notion that level and consistency of participation in physical activity, resulting in improved CRF

as measured by greater treadmill time, are the reasons for postoperative RYGB patients to maintain and/or regain less weight over time (i.e., from 2 to 6 years). Post-RYGB surgery patients typically reach their nadir of weight loss around 2 years and then generally regain approximately 5 to 7% of the total weight loss during the next few years.

Therefore, the finding that greater CRF over the 2- to 6-year period predicted less weight regain is an important clinical finding and provides support for postoperative patients and their caregivers to strongly encourage regular participation in physical activity.

While this study did not provide self-reported measures of participation by patients in physical activity, there are a number of observational studies using self-reported physical activity recall questionnaire data and a few studies using accelerometers with questionnaires to assess degree of physical activity participation following bariatric surgery,[11-15] although these studies have generally assessed physical activity engagement for less than 1 year. The reported general consensus from these studies is that physical activity increases following bariatric surgery and that involvement in physical activity is associated with weight loss. As indicated, the unique aspect of the Utah study was long-term measurement of CRF using an exercise treadmill test. To date, there are very little data assessing direct measurement of CRF change before and following bariatric surgery. In a study of 109 patients with severe obesity (mean BMI 48.7 ± 7.2 ; range, 36.0 to 90.0 kg/m²), medical charts were abstracted to obtain CRF measured prior to their undergoing RYGB surgery. Following surgery, the lowest tertile of CRF (< 15.8 ml/kg/min) was significantly associated with greater short-term postsurgical complications ($p=0.02$) compared to patients whose presurgical CRF was > 15.8 ml/kg/min. From Brazil, de Sousa et al. measured CRF (exercise treadmill

test) on 65 consecutive severely obese patients before, 6 and 12 months following RYGB surgery. The time on treadmill for the 3 measurement periods was 5.4 ± 1.4 , 6.4 ± 1.6 , and 8.8 ± 1.0 min, respectively. These values represented a significant increase from pre-op to 6- and 12-months post-op ($p=0.001$).[34] A similar study measured CRF before and 1 year following bariatric surgery (type of surgery was not indicated) in 31 severely obese patients. The time on treadmill was significantly increased at 1-year post-op compared to pre-op (13.8 ± 3.8 to 21.0 ± 4.2 min; $p<0.001$). The authors also noted that patients performed each specific workload at a “lower oxygen consumption” and heart rate post-operatively compared to that obtained before surgery, suggesting that following bariatric surgery, patients were able to perform physical-related work at a lower energy expenditure.[35] These data support the findings of our Utah study and the notion that obese persons may expend greater energy performing the same amount of work as a more normal weight individual.[36] That is, perhaps the severely obese person simply requires (or expends) greater energy (cardiovascular and otherwise) to move their large body mass.[35]

Also unique to this study was the measurement and subsequent adjustment of resting energy expenditure (REE) and fat free mass. When REE measured at year 2 and change in REE from 2 to 6 years were included as covariate adjustments for change in weight and change in treadmill time (2 to 6 years), REE was shown to be highly related to 2- to 6-year weight change. Although a significant reduction in REE was from baseline to year 2 was shown in this study (a result of reduced total mass and fat free mass), the high degree of association between change in REE and favorable weight loss change (i.e., less weight regain) may suggest REE in relation to the postsurgical patient’s muscle mass

may be a favorable predictor of weight loss maintenance. Finally, because energy is primarily consumed within muscle mass, total treadmill time relative to fat free mass was used in this study to better assess the energy efficiency of the RYGB patients both before and following their surgery. Indeed, the change in total treadmill time relative to fat free mass increased the significance of the association with 2- to 6-year weight change.

Limitations of this study include the use of a submaximal exercise treadmill test (i.e., 80% of predicted maximal heart rate) at baseline but a maximal-based treadmill test at years 2 and 6. The reason for the decision to vary the study protocol and shift to a maximal exercise test was because maximal exercise tests are deemed to more accurately predict maximal CRF. However, the change in protocol between baseline and year 2 disallowed for any comparison in change in CRF (i.e., difference in total treadmill time) during this time period. However, the opportunity to assess change in treadmill time during the critical period when most RYGB surgery patients regain weight was possible (i.e., both years 2 and 6 were maximal CRF tests). The low participation rates at year 6 were also a limitation of this study. A number of study patients chose to come to our outpatient clinic for the 6-year examination rather than spend the night at the CCTS, and a treadmill test was not available at our outpatient clinic. However, a high percentage of patients who did choose to return to the CCTS for 2- and 6-year examinations also agreed to undergo a maximal exercise test (95% plus). We recognize that there is a high probability that those patients who did not return for participation at year 2 and year 6 may be study participants who were not as successful with weight loss or weight loss maintenance and may have also represented those who were less physically active. However, this does not necessarily bias the finding that the more favorable change in

CRF from year 2 to 6 predicted the more favorable weight loss change outcome.

Strengths of this study include a very large number of RYGB surgical patients studied before and at 2 and 6 years following their surgery. As previously indicated, this study represents the only long-term follow-up of RYGB patients where CRF has been measured, rather than assumed due to favorable self-reported physical activity questionnaires following surgery or accelerometer data.

In conclusion, previous studies related to physical activity and associated cardiorespiratory fitness among the bariatric surgery population have been limited to assessment short-term postsurgical follow-up. The findings of this study are the first to demonstrate that favorable changes in CRF following RYGB surgery can have a positive influence upon reducing the risk of long-term weight regain following surgery. These findings also support clinical guidelines that recommend patients undergoing bariatric surgery should be well-informed of the importance to build in a lifetime of participation in physical activity following surgery.

References

1. Trus, T.L., G.D. Pope, and S.R. Finlayson, *National trends in utilization and outcomes of bariatric surgery*. Surg Endosc, 2005. **19**(5): p. 616-20.
2. Davis, M.M., et al., *National trends in bariatric surgery, 1996-2002*. Arch Surg, 2006. **141**(1): p. 71-4; discussion 75.
3. Buchwald, H. and D.M. Oien, *Metabolic/bariatric surgery worldwide 2011*. Obes Surg, 2013. doi: **10.1007/s11695-012-0864-0**.
4. van Hout, G.C., S.K. Verschure, and G.L. van Heck, *Psychological predictors of success following bariatric surgery*. Obes Surg, 2005. **15**(4): p. 552-60.
5. Anderson, J.R., et al., *Predictors of weight loss are different in men and women after sleeve gastrectomy*. Obes Surg, 2014. **24**(4): p. 594-8.

6. Arterburn, D., et al., *Predictors of long-term mortality after bariatric surgery performed in Veteran Affairs medical centers*. Arch Surg, 2009. **144**(10): p. 914-920.
7. Livhits, M., et al., *Preoperative predictors of weight loss following bariatric surgery: systematic review*. Obes Surg, 2012. **22**(1): p. 70-89.
8. Goodpaster, B.H., et al., *Effects of diet and physical activity interventions on weight loss and cardiometabolic risk factors in severely obese adults: a randomized trial*. JAMA, 2010. **304**(16): p. 1795-802.
9. Donnelly, J.E., et al., *American College of Sports Medicine: Appropriate physical activity intervention for weight loss and prevention of weight regain for adults*. Med Sci Sports Exerc, 2009. **41**(2): p. 459-71.
10. *National Institutes of Health (NHLBI): Clinical guidelines on the identification, evaluation, and treatment of overweight and obesity in adults: the evidence report*. Obes Res, 1998. **6**(2): p. 51S-209S.
11. Bond, D.S., et al., *Pre- to postoperative physical activity changes in bariatric surgery patients: self report vs. objective measures*. Obesity, 2010. **18**(12): p. 2395-7.
12. Bond, D.S., et al., *Objective quantification of physical activity in bariatric surgery candidates and normal-weight controls*. Surg Obes Relat Dis, 2010. **6**(1): p. 72-80.
13. Livhits, M., et al., *Exercise following bariatric surgery: systematic review*. Obes Surg, 2010. **20**: p. 657-65.
14. Jacobi, D., et al., *Physical activity and weight loss following bariatric surgery*. Obes Rev, 2011. **12**(5): p. 366-77.
15. King, W.C., et al., *Physical activity levels of patients undergoing bariatric surgery in the Longitudinal Assessment of Bariatric Surgery (LABS) Study*. Surg Obes Relat Dis, 2008. **4**(6): p. 721-38.
16. Adams, T.D., et al., *Health benefits of gastric bypass surgery after 6 years*. JAMA, 2012. **308**(11): p. 1122-31.
17. Adams, T.D., et al., *Design and rationale of the Utah obesity study. A study to assess morbidity following gastric bypass surgery*. Contemp Clin Trials, 2005. **26**(5): p. 534-51.
18. Mason, R.E. and I. Likar, *A new system of multiple-lead exercise electrocardiography*. Am Heart J, 1966. **71**(2): p. 196-205.

19. Mahler, D., et al., *ACSM Guidelines for Exercise Testing and Prescription*. Fifth Edition ed. 1995, Providence: Williams and Wilkins.
20. Medicine, A.C.o.S., *Guidelines for Exercise Testing and Prescription, Seventh Edition*. 2006, Philadelphia: Lippincott Williams and Wilkins.
21. Kolotkin, R.L., et al., *Cardiorespiratory fitness and health-related quality of life in bariatric surgery patients*. *Obes Surg*, 2011. **21**(4): p. 457-64.
22. LaMonte, M.J., *Fitness or fatness: Which has a higher relationship with selected coronary artery disease risk factors in Utah adult men and women?*, in *Department of Exercise and Sports Science*. 1997, University of Utah: Salt Lake City, UT. p. 300.
23. LaMonte, M.J., *Fitness or fatness: Which has a higher relationship with selected coronary artery disease risk factors in Utah adult women and men?*, in *Exercise and Sports Science*. 1997, University of Utah: Salt Lake City.
24. Caspersen, C.J., *Physical activity epidemiology: concepts, methods, and applications to exercise science.*, in *Exercise and sports science reviews*, K.B. Pandolf and J.O. Holloszy, Editors. 1989, Williams and Wilkins: Baltimore, MD. p. 423-69.
25. Casperson, C.J., K.E. Powell, and G.M. Christenson, *Physical activity, exercise, and physical fitness: definitions and distinctions for health-related research*. 100, 1985. **2**(126-31).
26. Pollock, M.L., et al., *ACSM position stand: The recommended quantity and quality of exercise for development and maintaining cardiorespiratory and muscular fitness, and flexibility in healthy adults*. *Med Sci Sports Exerc*, 1998. **30**(6): p. 975-91.
27. Willmore, J.H., *Design issues and alternatives in assessing physical fitness among apparently healthy adults in a health examination survey of the general population*. In: *Assessing Physical Fitness and Activity in General Population Studies.*, T.F. Drury, Editor. 1988, U.S. Public Health Service, National Center for Health Statistics: Washington, D.C. p. 107-40.
28. Paffenbarger, R.S. and S.n. Blair, *Exercise in the primary prevention of coronary heart disease.*, in *Heart Disease and Rehabilitation, 3rd Edition*, M.L. Pollock and D.H. Schmidt, Editors. 1995, Human Kinetics: Champaign, IL. p. 169-176.
29. Peltonen, M., A.K. Lindroos, and J. Torgerson, *Musculoskeletal pain in the obese: a comparison with a general population and long-term changes after conventional and surgical obesity treatment*. *Pain*, 2003. **104**: p. 549-57.

30. Karason, D., et al., *Relief of cardiorespiratory symptoms and increased physical activity after surgically induced weight loss. Results from the SOS study.* Arch Intern Med, 2000. **160**: p. 1797-802.
31. Sjostrom, L., et al., *Lifestyle, diabetes, and cardiovascular risk factors 10 years after bariatric surgery.* N Engl J Med, 2004. **351**(26): p. 2683-93.
32. Temelkova-Kurktschiev, T. and T. Stefanov, *Lifestyle and genetics in obesity and type 2 diabetes.* Exp Clin Endocrinol Diabetes, 2012. **120**: p. 1-6.
33. Ryden, A. and J.S. Torgerson, *The Swedish Obesity Subjects Study - what has been accomplished to date?* Surg Obes Relat Dis, 2006. **2**: p. 549-60.
34. de Souza, S.A., J. Faintuch, and A.F. Sant'anna, *Effect of weight loss on aerobic capacity in patients with severe obesity before and after bariatric surgery.* Obes Surg, 2010. **20**(7): p. 871-5.
35. Seres, L., et al., *Increased exercise capacity after surgically induced weight loss in morbid obesity.* Obesity, 2006. **14**(2): p. 273-9.
36. Mattsson, E., U. Evers Larsson, and S. Rossner, *Is walking for exercise too exhausting for obese women?* Int J Obes, 1997. **21**(380-6).

CHAPTER 3

ASSOCIATION OF GASTRIC BYPASS ON GESTATIONAL AGE AND WEIGHT OF CHILDREN BORN BEFORE AND FOLLOWING GASTRIC BYPASS SURGERY

Background

Long-term, clinically relevant sequelae of obesity include an increased risk for female infertility, maternal and perinatal pregnancy complications such as miscarriage, Cesarean section, gestational diabetes, hypertension, and fetal macrosomia.[1-6] Increased pregnancy-related health risks are especially apparent among severely obese women. [5, 6] Women who have participated in bariatric surgery represent an ideal population to appraise whether or not prepregnancy voluntary weight loss in severely obese women improves fertility and significantly reduces maternal and infant pregnancy complications. Studies have demonstrated that bariatric surgery results in significant and sustained weight loss[7, 8]; however, during the period of major weight loss (within the first 12 to 18 months following surgery) and perhaps thereafter, food intake restriction and/or malabsorption may inhibit maternal nutrient intake and compromise fetal growth.[4, 9, 10] Therefore, greater understanding of the benefits and risks associated with pregnancy following bariatric surgery has important clinical importance. Acquiring new insight related to bariatric surgery-related pregnancy is especially relevant in light of

the increasing number of pregnant women who have undergone bariatric surgery. This increase is due to 3 factors: bariatric surgery is increasing in popularity;[11-13] approximately 80% of all bariatric surgical procedures are performed on women;[14, 15] and a significant percentage of bariatric surgeries are undertaken during the female's reproductive years.[4]

This study builds upon previously reported investigations that have related pregnancy and bariatric surgery, but have employed wide variation in methodological approaches.[16-24] Using a large population of post-gastric-bypass women and a unique population-based, nonsurgical patient matching design, the aim of this study was to further test the association between gestational age and birth weight pregnancy outcomes occurring both before and following Roux-en-Y gastric bypass surgery.

Methods

Study Subjects

Two primary study populations were included in the study, surgical patients and nonsurgical subjects (see Figure 3.1). The surgical population consisted of a consecutive series of 5,819 female residents of Utah who had previously undergone Roux-en-Y gastric bypass surgery (RYGB) between 1979 and 2011 (performed by 6 bariatric surgeons representing a single Utah surgical practice, Rocky Mountain Associated Physicians, Inc.) and their live births ($n=13,112$). These surgical patients were linked with the Utah Population Database (UPDB), which holds Utah records for 15 million individuals connected from various sources, including genealogy records, inpatient hospital and ambulatory surgery records, driver's license records, and birth and death

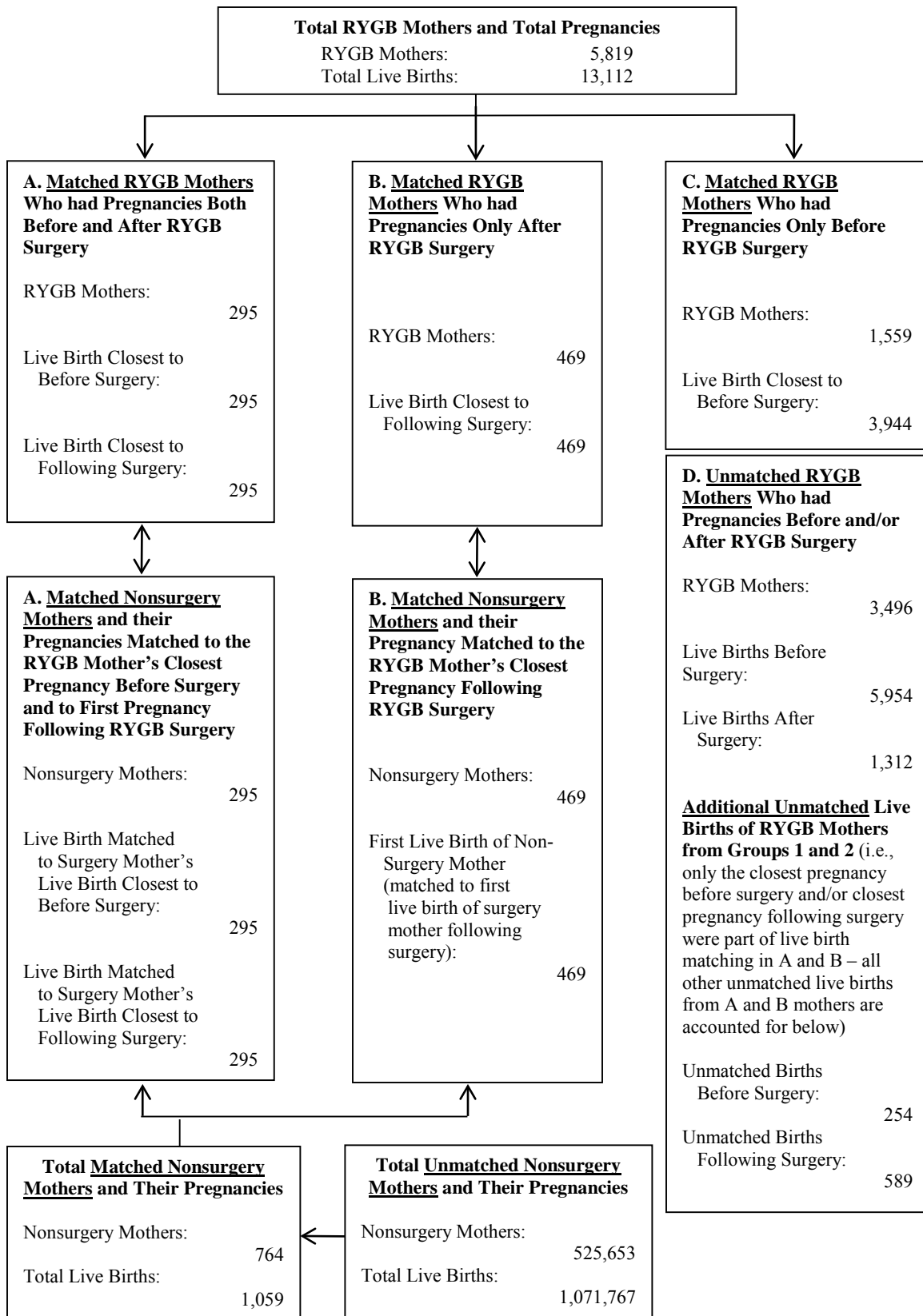

Figure 3.1. Roux-en-Y Gastric Bypass and Matched Nonsurgical Mothers and Neonates.

certificates.[25] Once linked, pregnancy patterns of all RYGB women were ascertained for the purpose of matching and statistical analyses. The nonsurgical population included Utah females ($n=525,653$) who had not undergone bariatric surgery and their live births ($n=1,071,767$), whose data were part of the UPDB (Figure 3.1). This population was used for matching purposes. Allocation of the surgical and nonsurgical subjects is detailed in Figure 3.1: matching (A and B); and nonmatched (C and D).

Study Groups

Three groups were considered for the purpose of analyses. Figure 3.2 illustrates the methods-related schemes employed for each of the groups. Groups 1 and 2 included matching of surgical and nonsurgical subjects, while Group 3 consisted only of RYGB patients. For study Group 1, the matching focused on RYGB mothers whose pregnancies had occurred both before and after RYGB surgery (see Figure 3.2; Group 1). Using the UPDB birth certificate records, nonsurgery women and their respective pregnancy data were matched 1-to-1 to these RYGP mothers and pregnancies. The following matching criteria were used: mother's birth year or birth age; mother's race (white/nonwhite); birth year for the neonate born closest to pre-RYGB surgery and birth year for the neonate born closest to post-RYGB surgery; birth order for the 2 pregnancies closest to pre- and post-RYGB surgery; total parity; birth multiplicity (i.e., singletons and twins); and prepregnancy BMI (kg/m^2) self-reported on the birth certificate of the RYGB mother for her pregnancy closest and prior to her RYGB surgery. The specific intent of analysis for Group 1 was to compare the neonate born to the RYGB mother closest to and before her surgery with the matched neonate of the nonsurgery mother and to then compare the

Group 1: Children born before and after Roux-en-Y gastric bypass surgery (RYGB)

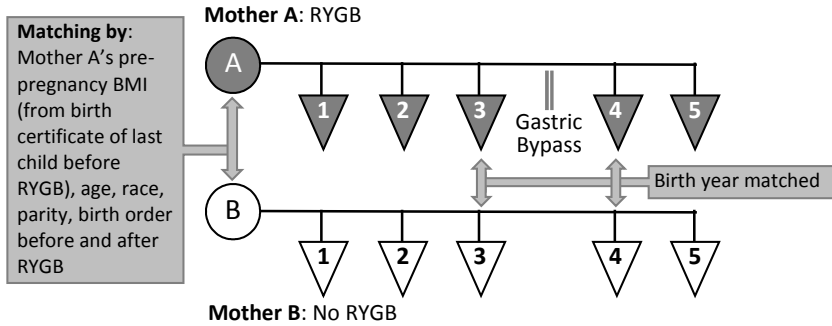

Group 2: Children born after RYGB surgery only combined with children born after surgery in Group 1 above (see dotted line).

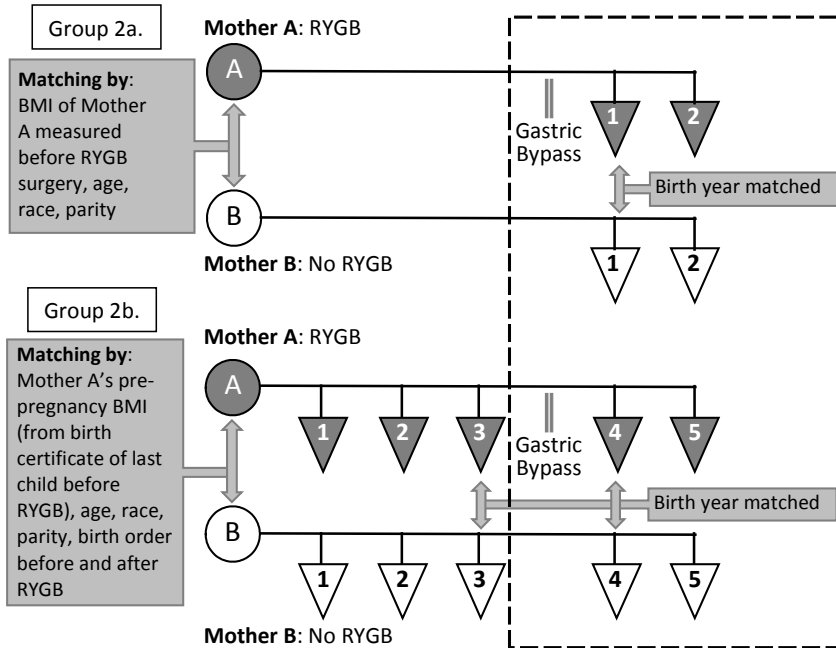

Group 3: All children born before and after Roux-en-Y gastric bypass surgery to RYGB mothers. No matched controls included.

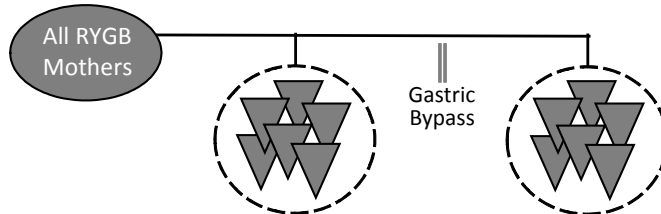

Figure 3.2. Matching Schemes.

neonate born to the RYGB mother closest to and following her surgery with the matched neonate of the nonsurgical mother (see Figure 3.2; Group 1).

Study Group 2 included a combination of 2 matched subgroups (see Figure 3.2, Group 2). The first subgroup (see Figure 3.2, Group 2a) included 1-to-1 matching of data of the RYGB mothers whose pregnancies had occurred only after her RYGB surgery. Data of the mother and her live birth associated with the first pregnancy that occurred after her RYGB surgery were matched with the data of the nonsurgery mother and her neonate. The matching criteria used for Group 2a included the mother's birth year or birth age; mother's race (white/nonwhite); birth year of the neonate of the closest pregnancy following RYGB surgery; birth order (in this case, the closest child born to the RYGB and the nonsurgical mothers (i.e., closest pregnancy that occurred after RYGB surgery); total parity; birth multiplicity (singleton and twins); and prepregnancy BMI (kg/m^2) of the RYGB mother measured just prior to her RYGB surgery. As depicted in Figure 3.2 by the dashed line, Group 2b (the post-RYGB surgery component of Group 1) was also included as part of Group 2 analysis (i.e., RYGB mother's neonates from Group 1 who represented the first pregnancy following surgery and their matched nonsurgical mother's neonates). The objective for Group 2 was to facilitate analysis of mothers and their live births that occurred following their RYGB surgery compared to matched nonsurgery mothers and their neonates. Categories used for matching prepregnancy BMI were: 18.5 to 24.9; 25.0 to 29.9; 30.0 to 34.9; 35.0 to 39.9; 40 to 49.9; and ≥ 50 . Group 3 did not involve maternal or neonate nonsurgical matching (see Figure 3.2, Group 3). Rather, this scheme simply included all live births of all RYGB women that had occurred prior to their surgery compared to all live births of all RYGB women following their

RYGB surgery, without specific reference to birth order for mothers with multiple births (i.e., the only live birth distinction was whether the neonate was born before or following RYGB surgery).

Data Extraction

Prepregnancy BMI was not reported on birth certificates in Utah prior to 1989 and as a result, nonsurgical women could only be selected from births occurring after 1989. Because Utah birth certificates do not give information on the total number of pregnancies, for the purpose of this study, parity was defined as total live births. Using this definition, a combination of 2 approaches were used to assess parity: 1) the maximum number of previous live births listed on a given mother's set of birth certificates; and 2) the total number of live born children available in UPDB. These 2 methodologies were used because the number of previous live births is not always accurately recorded and there may have been children born outside of Utah who would not be counted using the second approach. When the RYGB mother/pregnancy was part of a multiple birth set, all children in the set of multiple births were used, but they were required to match to a corresponding nonsurgery multiple birth. No RYGB women were selected as nonsurgery matched patients. Subsequent to the initial matching of RYGB- and nonsurgical-related subjects, where the majority of matches occurred, the matching criteria were somewhat relaxed. These conditions included combining the 2 BMI groups of 40 to 49.9 and ≥ 50 , grouping parity and birth order if ≥ 5 , and extending the child's birth year and/or the mother's birth year from ± 1 year to as much as ± 3 years. When the matching was relaxed on the birth year of the child, the mother's age instead of her birth

year was used so the birth intervals and mother's age at time of birth would be consistent for the subgroup where pregnancies occurred both before and after RYGB surgery. The percentage of exact matches for all subgroups combined was 78%.

Following the matching of patients and their pregnancies with nonsurgery mothers and their pregnancies, pregnancy-related information was extracted from the respective birth certificates. Birth weight, gestational age at birth, and Apgar scores at 1 and 5 min were obtained for all pregnancies. Additional maternal information extracted from the birth certificate included: age at delivery, race (white or nonwhite), Hispanic (yes or no), self-reported weight gain during pregnancy, smoker (yes or no), and self-reported maternal height and weight prior to becoming pregnant were extracted from the birth certificates. The actual surgical date of gastric bypass patients was used to calculate the time between the closest delivery prior to RYGB surgery and surgery as well as the time from RYGB surgery to the closest delivery occurring after surgery. The extraction of maternal- and neonatal-related complications were also extracted from each birth certificate and results from these data will be analyzed and reported in a subsequent report.

Two sets of criteria were used to clinically evaluate the birth weight of newborns.[26, 27] One birth weight guideline focused solely on the absolute weight of the baby, without reference to the gestational age when birth occurred. These criteria identified macrosomia, also referred to as high birth weight (HBW), as greater than 4000 grams (8 pounds 13 ounces) with 2 low-related birth weight ranges; very low birth weight (VLBW) less than 1500 grams (3 pounds 5 ounces), and low birth weight (LBW) less than 2500 grams (5 pounds 8 ounces). Normal birth weight for infants was, therefore,

defined as a birth weight between 2500 and 4000 grams (5 pounds 8 ounces to 8 pounds 13 ounces). The second criteria for birth weight status related the infants birth weight to gestational age (weeks) at birth. These criteria were sex dependent and included 3 categories: large for gestational age (LGA), which was a birth weight greater than the 90th percentile of birth weight for a given gestational age; appropriate for gestational age (AGA) indicated by a birth weight between the 10th and 90th percentile in relation to gestational age; and small for gestational age (SGA), less than the 10th percentile of birth weight in relation to gestational age. For additional clinical analysis, gestational age at birth (measured in weeks) criteria included < 37 weeks as preterm, 37 to 41 weeks as normal term, and > 41 weeks as extended term.

Statistical Analysis

A *t*-test was used to assess how well the RYGB subgroups were matched with the nonsurgical groups (i.e., age of mothers, birth year of babies, and self-reported BMI) and presented as means \pm standard deviations. A X^2 test was used to compare frequency differences between the RYGB and nonsurgical maternal race (white/nonwhite), Hispanic (yes/no), and smoking. For analyses of Groups 1 and 2 (matched surgical and nonsurgical subjects), conditional logistic regression, adjusted for sex of the neonate, was used to determine the odds ratios and 95% confidence intervals between the 2 study groups with reference to birth weight (with and without reference to gestational age at birth) and to gestational age at birth. For Group 3, (no subject matching) logistic regression, adjusted for sex of neonate, mother's age at delivery, number of previously born children (i.e., birth order), mother's race (white or nonwhite), and repeated measures for multiple

pregnancies was used to test for birth weight and gestational age at birth. For Group 3 logistic regression analysis of the birth weight category less than 1500 grams, there was repeated measures adjustment for multiple pregnancies due to the small sample size. Significance level was set at $P < 0.05$ and the study data were analyzed using SAS.

Results

Figure 3.1 details the number of matched mothers and live births for Groups 1 and 2, with Group 1 including 295 matched surgical and nonsurgical mothers and 295 before- and 295 after-RYGB surgery matched live births. Group 2 (Groups 2a and 2b combined) contained 764 total matched mothers and 754 matched neonates who were all born the first pregnancy following RYGB surgery. Group 3 (unmatched subjects) included 5819 mothers who had live births both before RYGB surgery ($n=4931$ births) and/or live births following surgery ($n=2,666$ births). Table 3.1 includes maternal and pregnancy-related descriptive characteristics for each of the 3 groups. For Groups 1 and 2, the mean maternal age at delivery (pre- and post-RYGB surgery) were not significantly different between the surgical and nonsurgical mothers ($p=0.53$ for both pre- and postsurgery). For Group 1, differences in prepregnancy BMI (self-reported birth certificate) for matched surgical and nonsurgical mothers prior to RYGB surgery were 36.1 ± 6.5 and 35.1 ± 6.2 kg/m^2 , respectively ($p < 0.0001$) and as expected, post-RYGB surgery prepregnancy BMI difference between surgical (27.6 ± 5.5 kg/m^2) and nonsurgical women (36.7 ± 7.7 kg/m^2) for Group 2 was significantly different ($p < 0.0001$). In Group 3, the prepregnancy BMI of all RYGB surgery mothers prior compared to following surgery was also, as expected, significantly different (34.7 ± 7.4 vs. 29.5 ± 6.2 kg/m^2 ; $p < 0.0001$). Maternal

Table 3.1. Maternal and Pregnancy-Related Characteristics for Groups 1-3.

Variables	Group 1: Pregnancies of RYGB Patients and Matched Nonsurgical Patients Occurring Both Before and Following RYGB Surgery After RYGB Surgery				Group 2: Pregnancies of RYGB Patients and Matched Nonsurgical Patients Occurring Only Following RYGB Surgery				Group 3: All Pregnancies of All RYGB Patients Occurring Both Before and Following RYGB Surgery			
	RYGB Patients	Nonsurgery Patients	P Value		RYGB Patients	Nonsurgery Patients	P Value		RYGB Patients Before Surgery	RYGB Patients After Surgery	P Value	
Maternal Age at Delivery, years	Mothers (n=295) Neonates (n=295)	Mothers (n=295) Neonates (n=295)	0.53		Mothers (n=764) Neonates (n=764)	Mothers (n=764) Neonates (n=764)	0.19		Mothers (n=4931) Neonates (n=10,477)	Mothers (n=1574) Neonates (n=2,666)	<0.0001	
Maternal BMI, prepregnancy, kg/m ²	25.5 ± 4.2	25.6 ± 4.2	0.53		27.6 ± 5.2	27.5 ± 5.2	0.19		26.4 ± 5.2	30.4 ± 5.3	<0.0001	
Maternal Race, White, n (%)	36.1 ± 6.5 (BC*)	35.1 ± 6.2 (BC*)	<0.0001		28.6 ± 5.7 (RYGB†)	40.0 ± 6.8 (BC*)	<0.0001		34.7 ± 7.4 (BC*)	29.5 ± 6.2 (BC)*	<0.0001	
Maternal, Hispanic, yes; n (%)	278 (94)	278 (94)	NA		730 (96)	730 (96)	NA		n=3465**	n=2209**	0.004	
Years Between Delivery and Surgery	2.8 ± 2.3	2.7 ± 2.4	0.12		730 (96)	59 (8)	NA		9,940 (96.6)	2469 (95.4)	0.004	
Total Parity, n	3.3 ± 1.2	3.3 ± 1.2	NA		59 (8)	59 (8)	NA		560 (5.4)	149 (5.8)	0.53	
Sets of Multiple Births, n (%)	1 (<1) 1 twin set	1 (<1) 1 twin set	NA		4.2 ± 3.2	4.2 ± 3.2	0.10		11.1 ± 7.3	4.8 ± 3.7	NA	
Birth Order of Pregnancy Just Prior to Surgery, n	1.94 ± 1.06	1.96 ± 1.14	0.94**		2.5 ± 1.3	2.5 ± 1.3	NA		3.8 ± 1.7	3.2 ± 1.6	<0.0001	
Apgar 1 min	7.6 ± 1.3	7.6 ± 1.4	0.62		6 (<1) 6 twin sets	6 (<1) 6 twin sets	NA		146**†† (2.8)	71**††† (5.5)	<0.0001	
Apgar 5 min	8.8 ± 0.8	8.8 ± 0.6	0.60		1	1	0.94*		2.64 ± 1.62	2.56 ± 1.51	NA	
Maternal Weight Gain, pounds	28.8 ± 16.9	22.9 ± 15.4	<0.0001		2.99 ± 1.07	3.02 ± 1.16	0.94*		7.55 ± 1.41	7.63 ± 1.35	0.009	
Smoke, yes; n (%)	18 (6.1)	27 (9.2)	0.59		20 (6.8)	33 (11.2)	0.86		8.76 ± 0.87	8.78 ± 0.82	0.18	
					27.4 ± 15.3	22.0 ± 15.7	<0.0001		27.7 ± 17.9	27.5 ± 15.4	0.64	
					62 (8.1)	70 (9.2)	0.88		n=3738	n=2202	<0.0001	
					62 (8.1)	33 (11.2)	0.86		313 (3.0)	194 (7.5)	<0.0001	

*BC = Prepregnancy birth certificate BMI (i.e., maternal prepregnancy BMI was obtained from self-reported birth certificate); †RYGB = Roux-en-Y gastric bypass measured BMI (i.e., BMI was obtained from presurgical measured BMI); **Birth certificates included maternal prepregnancy BMI only after 1989. As a result, the total N for mothers with birth certificate recorded BMI is slightly less than the total N for mothers identified in the table heading; ††142 twin sets; †††68 twin sets; ††††68 twin sets; †††††68 twin sets

race was predominantly white among all 3 groups (range, 94-96.6%), with 5.8 to 11% maternal Spanish reported among the groups. Little variation was seen between groups for total parity (range of 2.5 to 3.8) and nonsingleton births ranged from 2 to 5.5% across groups. The only significant difference in Apgar score was seen in Group 3 where the 1 min Apgar score was significantly greater for pre- vs. post-RYGB pregnancies (7.55 ± 1.41 vs. 7.63 ± 1.35 ; $p=0.009$). There were no significant differences, however, for the 5-min Apgar scores for Group 3. For Group 1 (pre- and postsurgery) and Group 2, the RYGB surgical mothers had significantly greater reported pregnancy weight gain when compared to the matched, nonsurgical mothers, all with a p value of <0.0001 . There were no reported differences in percentage of smokers between surgical and nonsurgical mothers for Groups 1 and 2, but for Group 3, the percentage of smokers for pre- versus post-RYGB surgery mothers was 3.0 vs. 7.5%, $p<0.0001$. post-RYGB surgery mothers was 3.0 vs. 7.5%, $p<0.0001$.

Birth weight and gestational age data for Groups 1-3 are detailed in Tables 3.2-3.4. When comparing the matched surgical and nonsurgical neonates born closest to and before RYGB surgery (Group 1; Table 3.2), there were no differences in odds ratios (OR) for birth weight or gestational weeks categories when compared to the referent groups. However, pregnancies related to Group 1 that were the first births following RYGB-surgery showed surgical neonates were significantly less likely to be born greater than 4000 grams (OR, 0.28; 95% CI, 0.11 to 0.61; $p=0.0025$) and a lower risk to be born large for gestational age (LGA) (OR, 0.16; 95% CI, 0.07 to 0.33; $p<0.0001$) compared to nonsurgical born neonates. Although not significant, there was a trend for surgical neonates born following RYGB surgery (Group 1) to have a greater risk for being born

Table 3.2. Group 1: Birth Weight and Gestational Age of Roux-en-Y Gastric Bypass Mother's Neonate Born Closest to Before Surgery and First Neonate Born After Surgery Compared to Matched Nonsurgery Mother's Pregnancies Matched to the RYGB Mother's Pregnancy Closest to Before Surgery and to First Pregnancy Following Surgery.

Neonatal Outcomes	Pregnancies Before RYGB			Pregnancies After RYGB			P value
	RYGB n=295	Nonoperated n=295	Adj. OR* (95% CI)	RYGB n=295	Nonoperated n=295	Adj. OR (95% CI)	
Gestational Age, weeks	38.82 ± 2.16	39.16 ± 1.86		38.07 ± 2.23	38.27 ± 2.36		0.25†
> 42 weeks, n	20	23	0.96 (0.51-1.77)	8	16	0.58 (0.22-1.45)	0.25
37-41 weeks, n	250	259	1	246	241	1	--
< 37 weeks, n	25	13	1.84 (0.92-3.84)	41	38	0.96 (0.53-1.76)	0.90
Birth weight, grams	3392 ± 572	3452 ± 486	0.18†	3102 ± 548	3380 ± 623		<0.0001†
> 4000 grams, n	29	36	0.73 (0.42-1.26)	10	34	0.28 (0.11-0.61)	0.0025
2500-4000 grams, n	252	251	1	255	244	1	--
< 2500-1500 grams, n	7	7	1.21 (0.36-4.21)	25	11	1.67 (0.70-4.24)	0.26
< 1500 grams, n	7	1	7.07 (1.26-132.4)	5	6	1.34 (0.21-10.43)	0.75
LGA (90 th %)**, n	35	32	1.34 (0.76-2.39)	10	48	0.16 (0.07-0.33)	<0.0001
AGA (11-89%)††, n	244	246	1	259	235	1	--
SGA (10 th %)***, n	16	17	0.81 (0.37-1.72)	26	12	2.20 (1.02-5.16)	0.054

*= Conditional logistic regression, adjusted for sex of neonate

†= Paired *t*-test.

**= LGA, Large for Gestational Age

††= NGA, Appropriate for Gestational Age

***= SGA, Small for Gestational Age

Table 3.3. Group 2: Birth Weight and Gestational Age of Roux-en-Y Gastric Bypass Mother's Neonate Born Closest to Following Surgery Compared to Matched Nonsurgery Mother's Neonate Matched to the Gastric Bypass Mother's Neonate Born Closest to Following Surgery.

Neonatal Outcomes	Pregnancies Only After RYGB			P value
	RYGB n=764*	Nonoperated n=764*	Adj. OR† (95% CI)	
Gestational Age, weeks	38.38 ± 2.34	38.31 ± 2.92		0.057**
> 42 weeks, n	15	27	0.53 (0.30-0.91)	0.024
37-41 weeks, n	650	626	1	--
< 37 weeks, n	96	108	0.81 (0.59-1.13)	0.22
Birth weight, grams	3092 ± 568	3292 ± 696		<0.0001**
> 4000 grams, n	30	83	0.33 (0.21-0.52)	<0.0001
2500-4000 grams, n	652	611	1	--
< 2500-1500 grams, n	68	44	1.43 (0.93-2.22)	0.11
< 1500 grams, n	14	26	0.56 (0.25-1.18)	0.14
LGA (90 th %), n††	33	99	0.33 (0.21-0.51)	<0.0001
AGA (11-89%), n***	636	619	1	--
SGA (10 th %), n†††	92	43	2.16 (1.43-3.32)	0.0003

*=Gestational age data were missing for 3 neonates born to RYGB mothers and 3 neonates born to nonsurgical mothers, As a result, the total N for gestational age data was 761.

†= Conditional logistic regression, adjusted for sex of neonate

**= Paired t-test.

††= LGA, Large for Gestational Age

***= AGA, Appropriate for Gestational Age

†††= SGA, Small for Gestational Age

Table 3.4. Group 3: Birth Weight and Gestational Age of All Neonates Born Before Surgery and All Neonates Born Following Surgery to All Roux-en-Y Gastric Bypass Mothers (no matching to nonoperated mothers or neonates).

Neonatal Outcomes	All Pregnancies Before RYGB and All Pregnancies After RYGB			P value
	RYGB Before n=10,477 (%)	RYGB After n=2,666 (%)	Adj. OR* (95% CI)	
Gestational Age, weeks	39.15 ± 2.22	38.26 ± 2.44		<0.0001†
> 42 weeks, n	1875 (18.0)	127 (4.8)	0.23 (0.19-0.28)	<0.0001
37-41 weeks, n	8021 (76.8)	2232 (83.7)	1	--
< 37 weeks, n	551 (5.3)	307 (11.5)	1.93 (1.62-2.31)	<0.0001
Birth weight, grams	3482 ± 598	3067 ± 592		<0.0001†
> 4000 grams, n	1676 (16.0)	95 (3.6)	0.19 (0.15-0.24)	<0.0001
2500-4000 grams, n	8309(79.5)	2201 (82.6)	1	--
< 2500-1500 grams, n	366 (3.5)	315 (11.8)	3.00 (2.45-3.66)	<0.0001
< 1500 grams, ** n	96 (0.9)	55 (2.1)	1.68 (1.15-2.44)	0.007
LGA (90th %), †† n	1892 (17.9)	268 (1.7)	0.22 (0.18-0.27)	<0.0001
AGA (11-89%), *** n	8121 (76.8)	2232 (83.7)	1	--
SGA (10th %), n†††	551 (5.3)	307 (11.5)	2.25 (1.89-2.69)	<0.0001

*= Logistic regression with repeated measures, adjusted for sex of neonate, mother's age at delivery, number of previously born children (i.e., birth order), mother's race (white or nonwhite), and repeated measures for multiple pregnancies.

†= Paired *t*-test.

**=No repeated measures adjustment for multiple pregnancies due to small sample size.

††= LGA, Large for Gestational Age

***= AGA, Normal for Gestational Age

†††= SGA, Small for Gestational Age

small-for-gestational-age (SGA) (OR, 2.20; 95% CI, 1.02-5.16; $p=0.054$).

RYGB Group 2, which focused only on the neonates born to RYGB mothers and nonsurgical matched mothers of the first pregnancy following RYGB surgery (Table 3.3), showed pregnancies of the surgical mothers were significantly less likely to extend beyond 42 weeks gestation compared to nonsurgical pregnancies (OR, 0.53; 95% CI, 0.30 to 0.91; $p=0.024$). In addition to a significantly smaller mean birth weight for neonates of surgical mothers compared to nonsurgical born neonates (3092 ± 568 vs. 3292 ± 696 grams; $p<0.0001$), neonates born to surgical mothers also had a significantly lower risk for a birth weight greater than 4000 grams or being born LGA ($p<0.0001$). However, the risk for having a SGA birth was significantly greater for the neonates born to RYGB surgical mothers compared to nonsurgical born neonates (OR, 2.16; 95% CI, 1.43 to 3.32; $p=0.0003$). Group 3 results (Table 3.4), contrasting all neonates born before surgery to all neonates born following RYGB surgery, were quite polarized with regards to the birth weight and gestational age categories. While neonates born to postsurgical mothers were at a significantly lower risk for deliveries greater than 42 weeks (OR, 0.23; 95% CI, 0.19 to 0.28; $p<0.0001$) compared to presurgical neonates, the postsurgery neonate deliveries were at a significantly greater risk to occur less than 37 weeks (OR, 1.93; 95% CI, 1.62 to 2.31; $p<0.0001$) compared to presurgical deliveries. This same pattern was evidenced in the results for LGA and SGA, where the postsurgical born neonates were significantly lower in risk for LGA (OR, 0.22; 95% CI, 0.18 to 0.27; $p<0.0001$), while at the same time there was a significantly greater risk for SGA (OR, 2.25; 95% CI, 1.89 to 2.69; $p<0.0001$) compared to presurgery born neonates.

Discussion

In view of the increased number of bariatric surgical procedures now undertaken in the U.S., with near 80% of all surgeries performed on females, there is an important clinical need to understand and appreciate potential benefits and risks of pregnancy in women following participation in bariatric surgery. This study of a large number of women who had undergone Roux-en-Y gastric bypass (RYGB) surgery and had experienced live birth pregnancies before and/or after RYGB surgery showed that following surgery, the risk of giving birth to a large-for-gestational-age neonate is significantly lower when compared to neonates born to matched, nonoperated mothers. However, study results also indicated that post-RYGB women were at a greater risk to deliver a small-for-gestational-age neonate.

Obesity has been associated with an increased risk for female-related fertility problems, especially related to ovulatory function.[1, 2] Obesity has also been associated with pregnancy complications, including an increased risk for miscarriage, C-section, gestational diabetes, and hypertension.[3, 4] In addition to complications related to the obese pregnant mother, prepregnancy maternal BMI has had a positive association with neonatal complications, including fetal macrosomia, high birth weight (HBW), and large-for-gestational-age (LGA) born neonates.[3, 4, 28-30]. In a recently published systematic review and meta-analysis of 45 studies comparing prepregnancy normal-weight mothers to prepregnancy obese mothers, there was a reported increased risk for LGA (OR, 2.08; 95% CI, 1.95-2.33), with similar odd ratios for macrosomia and HBW.[30] The incidence of LGA for live births in the U.S. in 2008 was 6.6.[31] The incidence of LGA reported among the Utah RYGB patients prior to their having had surgery was 11.9% (35/295;

LGA neonates/total neonates), or almost twice the U.S. incidence. This rate (11.9%) is somewhat less than the 16.4% LGA births reported Getahun et al., in a longitudinal study of over 12,000 live births born to obese women.[29]

In addition to maternal complications related to LGA, infants born with the diagnosis of LGA are a greater risk for a wide-variety of comorbidities.[32] Further, LGA-born neonates have an increased metabolic risk profile in childhood,[30, 33, 34] during adolescents,[35, 36] and into adulthood.[37] Thompson et al., tracking the National Health and Growth Study (NGHS) population to adulthood, reported children with reported onset obesity prior to age 12 years were 11 to 30 times more likely to present with obesity as adults. In addition to increased obesity risk, the overweight/obese NGHS children had a greater incidence of hypertension, hyperlipidemia, and metabolic syndrome as adults.[38]

Despite the significant positive association between maternal prepregnancy obesity and neonatal LGA, HBW, and macrosomia, studies have reported that even a minimal reduction in a woman's BMI may result in improved health status as well as lower risk for pregnancy-related complications,[17, 39] and that reduction in prepregnancy BMI can reduce the risk for LGA.[29, 40] A longitudinal retrospective study by Getahun et al., (2007) examined the first 2 consecutive singleton live births ($n=146,227$) to determine the association between prepregnancy BMI and LGA for their mother's first pregnancy and in contrast, the association between prepregnancy BMI and LGA for the same mother's second pregnancy. Results from this study indicated that when a mother's first prepregnancy BMI was in the obese range and subsequently reduced to the overweight or normal prepregnancy BMI for the second pregnancy, the

overall risk of her having a LGA birth was reduced.[29]

If minimal weight reduction has been shown to improve pregnancy-related outcomes, then it should follow that weight loss from bariatric surgery would also result in reduced pregnancy complications for the mother and the newborn. In this Utah study, a significantly lower risk ($p < 0.0001$) for high birth weight neonates (i.e., greater than 4000 grams) and for LGA neonates was evidenced when pregnancies of women who had undergone RYGB surgery were compared to matched pregnancies of nonoperated women (Groups 1 and 2), and when outcomes for live birth weights were compared between pregnancies that occurred before RYGB surgery and pregnancies after surgery (Group 3). These data represent a 67 to 84% reduction in risk for LGA births among the post-RYGB mothers when compared to nonoperated matched mothers or neonates born to RYGB surgery mothers prior to their surgery. A study by Kjaer et al. compared singleton deliveries following bariatric surgery ($n=355$ women with at least one live birth following surgery; 83.5% RYGB surgical procedures) to nonbariatric surgical women, matched for prepregnancy BMI, maternal age, and date of delivery.[16] They reported a lower risk for LGA births among the postbariatric surgical women compared to the nonoperated group (OR, 0.31; 95% CI, 0.15 to 0.65), or a 69% reduction in LGA risk. Although maternal and neonatal complications related LGA-related pregnancies are not reported as part of the Utah study, these data were collected as part of the birth certificate and plans are to analyze these outcomes in relation to LGA in the near future.

In contrast to the significantly lower risk for high birth weight and LGA among neonates born to post-RYGB surgery mothers compared to matched nonsurgical mothers, the Utah study also demonstrated a significantly greater risk for small-for-gestational-age

(SGA) births for post-RYGB surgery pregnancies. These findings of a greater risk for SGA following surgery were highly significant for Groups 2 and 3 and borderline significant for Group 1 ($p=0.054$). With the exception of a study by Kjaer et al.[16] and our Utah study, previous bariatric surgery pregnancy-related studies have only reported and increased risk for SGA birth when the bariatric surgery pregnancy outcomes have been compared to non-BMI matched populations.[4] The odds ratios for SGA of 2.20, 2.16, and 2.25 between postsurgical neonates and BMI-matched nonsurgical neonates for Groups 1, 2, and 3, respectively, of the Utah study are very similar to the odds ratio of 2.3 reported by Kjaer et al. who compared the first pregnancy following bariatric surgery of 339 women BMI-matched to nonsurgery mothers.[16] Small-for-gestational-age birth has been shown to be associated with a greater future risk for both diabetes and the metabolic syndrome for these babies.[41, 42] Although some SGA neonates may simply be smaller than normal as a result of their parents being small, cause for most SGA births appear to be associated with intrauterine growth restriction (IUGR), a condition that results from the fetus failing to receive adequate nutrients and oxygen for appropriate growth processes.[43] Roux-en-Y gastric bypass results in an anatomical bypassing of all but a small pouch of the stomach and the entire duodenum. As a result of the malabsorptive aspect of this surgery, there is the potential risk for nutritional deficiencies of the mother and the fetus. Subanalysis of the RYGB surgery mother's weight gain patterns for pregnancies occurring after their surgery suggested that although pregnancy weight gain was significantly greater for mothers who delivered LGA neonates compared to weight gain of mothers delivering AGA babies, there were no significant differences between pregnancy weight gain of mothers who had SGA neonates compared to

pregnancy weight gain of mothers delivering AGA babies. This may suggest that of the possible risks for a post-RYGB surgery mother having an SGA neonate, too little weight gain during pregnancy may not to be one of them. Long-term outcomes of SGA-born neonates have not been described. However, a study by Smith et al. that followed 111 siblings (age 2.5 to 26 years) who were born before and following maternal bariatric surgery (biliopancreatic diversion; a malabsorptive procedure) reported the children born following the surgery had a more favorable metabolic risk when compared to the children born before surgery.[44] Further, Guénard et al. analyzed the impact of maternal weight loss resulting from bariatric surgery by analyzing differential methylation in glucoregulatory genes (i.e., potential pathways involved with improved cardiometabolic processes) and markers for insulin resistance between offspring born before and after their mothers participated in bariatric surgery ($n=25$ before and 25 after surgery; ages 2 to 25 years).[45] The after-surgery sib had lower HOMA-IR, insulin, and blood pressure compared to before-surgery sibs, with over representation in glucoregulatory, inflammatory, and vascular disease pathways.[45] These results suggested potential epigenetics factors may influence the postbariatric surgical pregnancy outcome. Finally, a recent meta-analysis of 45 studies contrasted prepregnancy underweight, normal-weight, and overweight/obesity of women with SGA and LGA.[30] Overweight/obese prepregnancy increased the risk of LGA and high-body weight (HBW), whereas prepregnancy underweight was reported to increase the risk for SGA as well as low-body weight (LBW). However, the likelihood of post-RYGB surgery women reaching a BMI considered to be underweight is minimal.

The primary limitation of this study relates to the inherent self-reported biases of

ascertaining data through birth certificates. For example, the maternal prepregnancy BMI obtained from birth certificates (self-reported) of the neonate born closest to and before RYGB surgery may be less than the measured presurgery, prepregnancy BMI. It was this self-reported prepregnancy BMI that was used to match to the nonsurgical mother and her neonate, a match that could have resulted in a nonsurgical mother whose prepregnancy BMI was less than the RYGB prepregnancy BMI. However, if the nonsurgery mother's prepregnancy BMI were lower than that of the surgical mother, the statistical comparison for LGA should be conservative (i.e., with a lower nonsurgical mother's BMI, one would expect a lower rate of LGA births). Further, analyzing SGA in the context of a lower nonsurgical mother's BMI should also be conservative because one would hypothesize the nonsurgical mother to have a greater risk for SGA (lower mean prepregnancy BMI) in comparison to a greater prepregnancy BMI. Other limitations include the possibility of overmatching of the surgical mothers and neonates to the nonsurgical mothers and neonates.[46] This study design represented matching on more variables than any other bariatric surgery pregnancy study has employed. Therefore, the opportunity to adjust for various pregnancy-related factors was not possible. An additional limitation was that all clinical variables of the patients and subjects are self-reported and limited to birth certificate extraction (i.e., recorded by the delivering physician, nurse, or allied health professional).

To our knowledge, this study represents the first study to compare pregnancy outcomes both closest to and before surgery and first after surgery pregnancy among RYGB surgery patients and neonates with prepregnancy, BMI-matched, nonoperated subjects and their neonates. In addition, this study includes one of the largest cohorts of

post-RYGB surgery women and their offspring, with a high statistical power to detect differences in pregnancy outcomes before and following surgery (Group 3). Finally, the use of the Utah Population Database to provide matching between RYGB patients and respective birth certificates as well as to match to population-based, nonsurgical subjects and their pregnancies (i.e., 525,653 mothers and 1,071,767 live births) is deemed a strength of this investigation.

In conclusion, this uniquely designed study which explored pregnancy outcomes of RYGB surgical patients before and/or after surgery clearly demonstrated that following RYGB surgery, women are at a significantly reduced risk for having an LGA live birth. The short- and long-term clinical benefits of this reduced LGA risk are likely to be substantial. These results also indicate that post-RYGB surgery mothers are at a significantly greater risk to deliver an SGA neonate. The increased risk for SGA delivery raises considerable clinical concern related to potential nutritional deficiencies for both the mother and the developing fetus, a potential direct result of the restrictive and malabsorptive nature of this bariatric surgery. Greater exploration related to mechanisms that may account for the increased SGA risk following RYGB surgery as well as clinical surveillance of these SGA-born neonates during childhood, adolescence, and adulthood to determine long-term SGA outcomes are warranted.

References

1. Grodstein, F., M.B. Goldman, and D.W. Cramer, *Body mass index and ovulatory infertility*. *Epidemiology*, 1994. **5**(2): p. 247-50.
2. Lashen, H., K. Fear, and D.W. Sturdee, *Obesity is associated with increased risk of first trimester and recurrent miscarriage: matched case-control study*. *Hum Reprod*, 2004. **19**(7): p. 720-6.

3. Oveson, P., S. Rasmussen, and U. Kesmodel, *Effect of prepregnancy maternal overweight and obesity on pregnancy outcome*. *Obstet Gynecol*, 2011. **118**(2 Pt 1): p. 305-12.
4. Kjaer, M.M. and L. Nilas, *Pregnancy after bariatric surgery - a review of benefits and risks*. *Acta Obstet Gynecol Scand*, 2012. **92**: p. 264-71.
5. Weiss, J.L., et al., *Obesity, obstetric complications and cesarean delivery rate - a population-based screening study*. *Am J Obst Gynec*, 2004. **190**: p. 1091-7.
6. Kumari, A.S., *Pregnancy outcome in women with morbid obesity*. *Int J Gyn Ob*, 2001. **73**: p. 101-7.
7. Adams, T.D., et al., *Health benefits of gastric bypass surgery after 6 years*. *JAMA*, 2012. **308**(11): p. 1122-31.
8. Sjostrom, L., et al., *Lifestyle, diabetes, and cardiovascular risk factors 10 years after bariatric surgery*. *N Engl J Med*, 2004. **351**(26): p. 2683-93.
9. Mechanick, J.I., et al., *Clinical practice guidelines for the perioperative nutritional, metabolic, and nonsurgical support of the bariatric surgery patient - 2013 update: cosponsored by American Association of Clinical Endocrinologists, The Obesity Society, and American Society for Metabolic & Bariatric Surgery*. *Obesity*, 2013. **21**: p. S1-S27.
10. Miras, A.D. and C.W. le Roux, *Mechanisms underlying weight loss after bariatric surgery*. *Nat Rev Gastroenterol Hepatol*, 2013. **10**(10): p. 575-84.
11. Trus, T.L., G.D. Pope, and S.R. Finlayson, *National trends in utilization and outcomes of bariatric surgery*. *Surg Endosc*, 2005. **19**(5): p. 616-20.
12. Davis, M.M., et al., *National trends in bariatric surgery, 1996-2002*. *Arch Surg*, 2006. **141**(1): p. 71-4; discussion 75.
13. Buchwald, H. and D.M. Oien, *Metabolic/Bariatric surgery worldwide 2008*. *Obes Surg*, 2009. **19**(12): p. 1605-11.
14. Birkmeyer, N.J. and N. Gu, *Race, socioeconomic status, and the use of bariatric surgery in Michigan*. *Obes Surg*, 2012. **22**: p. 259-65.
15. Farinholt, G.N., et al., *A call to arms: obese men with more severe comorbid disease and underutilization of bariatric operations*. *Surg Endosc*, 2013. **27**: p. 4556-63.
16. Kjaer, M.M., et al., *The risk of adverse pregnancy outcome after bariatric surgery: A nationwide register-based matched cohort study*. *Am J Obst Gynec*, 2013. **208**: p. 464.e1-5.

17. Aricha-Tamir, B., et al., *Downsizing pregnancy complications: A study of paired pregnancy outcomes before and after bariatric surgery*. Surg Obes Relat Dis, 2012. **8**: p. 434-9.
18. Weintraub, A.Y., et al., *Effect of bariatric surgery on pregnancy outcomes*. Int J Gyn Ob, 2008. **103**: p. 246-51.
19. Marceau, P., et al., *Outcome of pregnancies after biliopancreatic diversion*. Obes Surg, 2004. **14**(3): p. 318-24.
20. Lesco, J. and A. Peaceman, *Pregnancy outcomes in women after bariatric surgery compared with obese and morbidly obese controls*. Obstet Gynecol, 2012. **119**: p. 547-54.
21. Santulli, P., et al., *Obstetrical and neonatal outcomes of pregnancies following gastric bypass surgery: A retrospective cohort study in a French referral centre*. Obes Surg, 2010. **20**: p. 1501-08.
22. Sheiner, E., et al., *Pregnancy after bariatric surgery is not associated with adverse perinatal outcome*. Am J Obst Gynec, 2004. **190**(1335-40).
23. Burke, A.E., et al., *Reduced incidence of gestational diabetes with bariatric surgery*. J Am Coll Surg, 2010. **211**: p. 169-75.
24. Bennett, W.L., et al., *Impact of bariatric surgery on hypertensive disorders in pregnancy: retrospective analysis of insurance claims data*. Br Med J, 2010. **340**: p. c1662.
25. Wylie, J.E. and G.P. Mineau, *Biomedical databases: protecting privacy and promoting research*. TRENDS in Biotech, 2003. **21**(3): p. 113-116.
26. Yerushalmy, J., *The classification of newborn infants by birth weight and gestational age*. J of Pediatrics, 1967. **71**(2): p. 164-73.
27. Battaglia, F.C. and L.O. Lubchenco, *A practical classification of newborn infants by weight and gestational age*. J of Pediatrics, 1967. **71**(2).
28. Siega-Riz, A.M., et al., *A systematic review of outcomes of maternal weight gain according to the Institute of Medicine recommendations: birthweight, fetal growth, and postpartum weight retention*. Am J Obstet Gynecol, 2009. **201**(4): p. 339.e1-14.
29. Getahun, D., et al., *Changes in prepregnancy body mass index between the first and second pregnancies and risk for large-for-gestational-age birth*. Am J Obst Gynec, 2007. **196**: p. 530e1-8.

30. Yu, Z., et al., *Prepregnancy body mass index in relation to infant birth weight and offspring overweight/obesity: A systematic review and meta-analysis*. PloS One, 2013. **8**(4): p. e61627.1-11.
31. Martin, J.A., et al., *Births: final data for 2006*. Nat Vital Stat Rep, 2010. **59**: p. 1 (http://www.cdc.gov/nchs/data/nvsr59/nvsr59_01.pdf) Accessed on April 22, 2014).
32. Boulet, S.L., et al., *Macrosomic births in the United States: determinants, outcomes, and proposed grades of risk*. Am J Obst Gynec, 2003. **188**: p. 1372-8.
33. Gaillard, R., et al., *Childhood cardiometabolic outcomes of maternal obesity during pregnancy: the Generation R Study*. Hypertension, 2014. **63**: p. 683-91.
34. Zhang, S., et al., *Maternal obesity and the early origins of childhood obesity: weighing up the benefits and costs of maternal weight loss in the periconceptional period for the offspring*. Exp Diab Res, 2011. **2011**: p. ID 585749.
35. Sorenson, H.T., et al., *Relation between weight and height at birth and body mass index in young adulthood*. BMJ, 1997. **315**: p. 1137.
36. Seidman, D.S., et al., *A longitudinal study of birth weight and being overweight in late adolescence*. Am J Dis Child, 1991. **145**: p. 782-85.
37. Drake, A. and R.M. Reynolds, *Impact of maternal obesity on offspring obesity and cardiometabolic disease risk*. Reproduction, 2010. **140**: p. 387-98.
38. Thompson, R.R., et al., *Childhood overweight and cardiovascular disease risk factors: the National Heart, Lung, and Blood Institute Growth and Health Study*. J Pediatr, 2007. **150**(1): p. 18-25.
39. Jacobson, H.N., et al., *Effect of weight reduction in obese pregnant women on pregnancy, labor, and delivery, and on the condition of the infant at birth*. Am J Obst Gynec, 1962. **83**: p. 1609-16.
40. Thangaratinam, S., et al., *Interventions to reduce or prevent obesity in pregnant women: A systematic review*. Nat Inst Tech, 2012. **16**(31).
41. Maes, T., *Fetal origins of insulin resistance and the metabolic syndrome: A key role for adipose tissue?* Diab Metab, 2010. **36**: p. 11-20.
42. McCowan, L. and R.P. Horgan, *Risk factors for small gestational age infants*. Best Pract Res Clin Obstet Gynaecol, 2009. **23**(6): p. 779-93.
43. Rochester, U.o. *Small for gestational age*. URM Health Encyclopedia, 2014.

<http://www.urmc.rochester.edu/Encyclopedia/Content.aspx?ContentTypeID=90&ContentID=P02411> (accessed April 22, 2014).

44. Smith, J., et al., *Effects of maternal surgical weight loss in mothers on intergenerational transmission of obesity*. J Clin Endocrinol Metab, 2009. **94**(11): p. 4275-83.
45. Guenard, F., et al., *Differential methylation in glucoregulatory genes of offspring born before vs. after maternal gastrointestinal bypass surgery*. PNAS, 2013. **110**(28): p. 11439-44.
46. Wacholder, S., et al., *Selection of controls in case-control studies*. Am J Epidemiol, 1992. **135**: p. 1042-50.

CHAPTER 4

ASSOCIATION OF PATIENT'S AGE AT GASTRIC BYPASS SURGERY WITH LONG-TERM ALL-CAUSE AND CAUSE-SPECIFIC MORTALITY

Background

The opportunity to explore the equivocal association between voluntary weight loss and long-term mortality [1, 2] has been made possible by studying patients who have undergone bariatric surgery, a treatment that results in significant and sustained weight loss.[3, 4] Since the initial retrospective mortality study by MacDonald et al., comparing diabetic patients who underwent gastric bypass surgery and diabetic patients who were seeking but did not have surgery,[5] a number of controlled retrospective bariatric surgery mortality studies,[6-12] a few retrospective studies without control groups,[13, 14] and one prospective matched control study[15] have been reported. In addition, at least 2 bariatric surgery meta-analysis studies related to long-term mortality have been published.[16, 17] From these data, the general consensus has been that long-term all-cause mortality and most often, cardiovascular- and cancer-specific mortality is favorably impacted for patients who have previously undergone bariatric surgery. One reported exception was a study by Maciejewski et al.[12] whose study included strict propensity score matching and reported no significant difference in mortality outcomes between

surgical and control groups who were followed for an average of 6.7 years. Unique to this study was the inclusion of bariatric surgical and nonoperated patients of Veterans Affairs medical centers who represented an older mean age (mean 49.5 years) and a much greater proportion of males (77.9% males) compared to other bariatric surgery studies.[12]

Further, at least 2 retrospective mortality studies have reported increased rates of deaths related to suicides, poisonings of undetermined intent and non-drug-related accidents among postbariatric surgical patients compared with nonoperated subjects.[6, 18]

From these long-term mortality data, at least 2 important clinical-related questions arise. Does the reported mortality benefit for all-cause and cause-specific deaths extend to all bariatric surgical patients regardless of what age they undergo surgery? Second, does the age at which bariatric surgery is performed have an association with future risk of death from external causes of death, such as suicide, poisonings and accidents?

Drawing upon a previously published long-term mortality study of Utah-based Roux-en-Y gastric bypass patients,[6] the primary aim of this investigation was to test the association between age-specific all-cause and cause-specific mortality among postgastric bypass patients matched to severely obese nonoperated subjects. Results from this study may provide clinicians with additional information to share with patients who are considering bariatric surgery or who have undergone surgery and may be deemed at greater risk for deaths from suicide, poisoning, or accidents.

Methods

Study Groups

This investigation was approved by the Institutional Review Board of the University of Utah. Requirements established by federal and state governments to maintain strict confidentiality were followed during the course of the study. Selection of subjects for this age-stratified retrospective study has been previously described.[6] In brief, from a consecutive series of 9949 post-Roux-en-Y gastric bypass patients and 9628 severely obese ($\text{BMI} \geq 33 \text{ kg/m}^2$) Utah drivers license and identification (ID) applicants, one-to-one matching was performed for 7925 patients and nonoperated subjects. Matching criteria included sex, BMI, age (with 5-year categories), and year of surgery matched with the year of application for a driver's license or ID card. The BMI matching was conducted using 3 BMI categories: 33 to 44, 45 to 54, and 55 (kg/m^2) or more, with the surgical patients presurgical BMI used to match with the nonoperated subjects' adjusted, self-reported BMI (methods used to produce sex-specific, correction regression equations have been previously described[6]). Data obtained on all matched, nonoperated subjects were cross-referenced with all gastric bypass patients and with the Utah Health Department's hospital registry to eliminate any of these subjects who had previously undergone bariatric surgery from 1992 to 2002. Gastric bypass patients and severely obese, nonoperated groups were stratified in 4 age-group intervals: less than 35 years; 35 to 44 years; 45 to 54 years; and greater than 55 years. All subject data were linked to the Utah Cancer Registry (part of the National Cancer Institute's Surveillance, Epidemiology, and End Results program) to eliminate cases of prevalent cancer and were also sent to the National Death Index (NDI) bureau to identify death status and causes of

death as categorized by ICD-9 and ICD-10 classifications. The NDI used name, sex, date of birth, and Social Security number (when reported) and probability-based algorithms[19] to match the gastric bypass and nonoperated groups with their national death database. Finally, a series of sensitivity-based measures, previously described,[6] were carried out to assess impact of potential study bias.

Statistical Analysis

Using Cox proportional-hazards regression analysis, the risk of death between the Roux-en-Y gastric bypass and the matched nonoperated subjects group for each of the 4 specific age categories was performed. Each age group was analyzed separately and within these separate analyses, sex was stratified. For each age category, the survival time was computed as the difference between the date of death for decedents, or January 1, 2003 for survivors, and baseline date, defined as the date of bariatric surgery for the patient group and the date of drivers license or ID card application for the nonoperated group. Similar to the previous study, sex, baseline age, year of bariatric surgery or the year of license or ID application, and a cubic polynomial of BMI at baseline were used in the statistical model for each age category. The absolute death rates (unadjusted) are represented as deaths per 10,000 person-years of follow-up. The p-values and the 95% confidence intervals are all 2-sided and criteria used for statistical significance was a p-value less than 0.05. Statistical analyses were conducted using SAS software, version 9.1.

Results

Table 4.1 highlights the descriptive data for all Roux-en-Y gastric bypass patients and all matched nonoperated subjects as well as the data for age-specific categories, including number of subjects per age category, sex, BMI, and follow-up in years and person-years. While there were no significant differences between the 2 groups for mean follow-up time for all ages combined and for age-specific categories, mean BMI was consistently greater ($p < 0.0001$) for the nonoperated groups (all and age-specific) compared to the surgical group. Over the total follow-up period of 18 years (mean of 7.1 years), there were 213 and 321 total deaths reported for the postsurgical and nonoperated groups, respectively (Table 4.2). Total deaths (i.e., all-cause mortality) were consistently greater among the nonoperated controls within the age-specific groups, with the exception of the less than 35 years old subgroup, where the surgical group reported 69 all-cause mortality deaths compared to 50 total deaths for the nonoperated subjects. The primary reason for the higher number of deaths among the operated versus nonoperated groups in the less than 35 years of age category was due to externally caused deaths, where the surgical deaths were 63 and the nonoperated subject deaths were 36. Deaths caused by all diseases (defined as all deaths except externally-caused deaths), cardiovascular disease, and cancer were reduced among the surgical patients compared to the corresponding nonsurgical subgroups within the combined age group and each separate age category (Table 4.2).

As previously published,[6] the rate of death related to all-cause mortality for all ages combined was 40% lower among the gastric bypass group when compared to the nonoperated control group (hazard ratio (HR), 0.60; 95% confidence interval (CI), 0.45 to

Table 4.1. Descriptive Characteristics of Post Roux-en-Y Gastric Bypass Surgery Patients and Nonoperated Matched Subjects.

Characteristic	Group	All	Age Categories, years			
			<35	35-44	45-54	>55
Number of Subjects	Surgery	7925	2730	2762	1828	605
	Nonoperated	7925	2730	2762	1828	605
Female Sex (%)	Surgery	84	87	84	80	76
	Nonoperated	84	87	84	80	76
Mean Age (years)*	Surgery	39.5 ± 10.5	28.1 ± 5.0**	39.9 ± 2.8 [‡]	49.4 ± 2.8	59.1 ± 3.3
	Nonoperated	39.3 ± 10.6	27.8 ± 5.0	39.6 ± 2.9	49.3 ± 2.9	59.0 ± 3.4
BMI (kg/m²)[†]	Surgery	45.3 ± 7.4 [‡]	45.2 ± 7.4 [‡]	45.4 ± 7.5 [‡]	45.4 ± 7.4 [‡]	45.2 ± 7.0 [‡]
	Nonoperated	46.7 ± 6.3	46.7 ± 6.3	46.8 ± 6.2	46.6 ± 6.4	46.4 ± 6.3
Mean Follow-up (years)	Surgery	7.1 ± 5.4	7.6 ± 5.5	7.6 ± 5.4	6.4 ± 5.3	5.7 ± 5.1
	Nonoperated	7.1 ± 5.4	7.6 ± 5.6	7.5 ± 5.4	6.3 ± 5.2	5.5 ± 5.0
Person-years	Surgery	56,618	20,637	20,862	11,677	3,326
	Nonoperated	56,237	20,778	20,697	11,436	3,440

*Plus-minus values are means ±SD.

[†]BMI = Body Mass Index (weight in kilograms divided by the square of the height in meters) was calculated from the presurgically measured height and weight of the gastric bypass group and from the self-reported height and weight found on the drivers license and ID card applications corrected with the use of sex-specific regression equations in the nonoperated group.

** $p < 0.05$

[‡] $p < 0.001$ for the comparison with the nonoperated group.

Table 4.2. Distribution of Deaths and Death Rates per 10,000 Person-Years, According to Study Group and Stratified by Age Categories.

All deaths	Causes of Death	Group	All	Age Categories, years			
				<35	35-44	45-54	>55
	Deaths (N)	Surgery	213	69	58	51	35
	Deaths no./10,000 person-yr	Nonsurgery	321	50	96	111	64
		Surgery	37.6	33.4	27.8	43.7	105.2
		Nonsurgery	57.1	24.1	46.4	97.1	186.0
	Deaths (N)	Surgery	150	34	41	43	32
		Nonsurgery	285	38	81	105	61
	Deaths no./10,000 person-yr	Surgery	26.5	6.0	7.2	7.6	5.7
		Nonsurgery	50.3	6.7	39.1	50.7	29.5
	Deaths (N)	Surgery	55	11	14	16	14
		Nonsurgery	104	18	27	33	26
	Deaths no./10,000 person-yr	Surgery	9.7	1.9	2.5	2.8	2.5
		Nonsurgery	18.5	3.2	13.0	15.9	12.6
	Deaths (N)	Surgery	31	0	10	12	9
		Nonsurgery	75	8	20	32	15
	Deaths no./10,000 person-yr	Surgery	5.5	0	1.8	2.1	1.6
		Nonsurgery	13.3	1.4	9.7	15.5	7.2
	Deaths (N)	Surgery	63	35	17	8	3
		Nonsurgery	36	12	15	6	3
	Deaths no./10,000 person-yr	Surgery	11.1	6.2	3.0	1.4	0.5
		Nonsurgery	6.4	2.1	7.2	2.9	1.4

*Deaths that were caused by disease include all deaths minus those deaths caused by external causes such as accidents unrelated to drugs, poisonings of undetermined intent, suicides, and other externally-caused deaths.

†Coronary artery disease, heart failure, stroke, and other cardiovascular disease.

‡Accident unrelated to drugs, poisoning of undetermined intent, suicide, and other externally-caused deaths.

0.67); $p < 0.0001$) (Table 4.3). Further, for all ages combined, the deaths caused by accidents unrelated to drugs, poisonings of undetermined intent, suicide, and other nondisease causes were 1.58 times as great for the gastric bypass group compared to the nonoperated subject group (HR 1.58; 95% CI, 1.02 to 2.45; $p = 0.04$) (Table 4.3). The less than 35 years of age category showed a HR value of 1.22 (95% CI, 0.82 to 1.81; $p = 0.34$) for all-cause mortality when the surgical was compared to the nonsurgical groups, and this increased risk, while not significant, appeared to primarily be the result of a 2.53 times greater death for external causes (95% CI, 1.27 to 5.07; $p = 0.009$) in the surgical patients compared to the nonsurgical subjects less than age 35 years. Otherwise, with reference to all external caused deaths, there were no significant differences for the other 3 age categories greater than 35 years. With the exception of the less than 35 years age category, all other age categories showed a significantly lower percentage for all deaths caused by disease among the surgical patients versus the nonoperated subjects, (57%, 61%, and 54% for ages 35-44, 45-54, and greater than 55 years, respectively). Death from all cardiovascular disease and from all cancers were significantly lower for the post-gastric bypass group compared to the nonoperated subjects for ages 45-54 years ($p = 0.003$ and $p = 0.02$ for cardiovascular deaths and cancer deaths, respectively), with a similar trend for the ages 35-44 years and greater than 55 years age categories ($p = 0.08$ and $p = 0.12$, respectively, for cardiovascular deaths and $p = 0.16$ and $p = 0.19$, respectively, for cancer deaths). Figures 4.1 through 4.4 illustrate the hazard ratios and 95% confidence intervals for all-cause and cause-specific outcomes with reference to the specific age categories.

Table 4.3. Adjusted Hazard Ratios* for Death in the Gastric Bypass Surgery Groups as Compared with the Nonsurgery Group by Age-stratification.

End Point	Age Categories, years														
	All			<35			35-44			45-54			>55		
	Hazard Ratio (95% CI)	P Value		Hazard Ratio (95% CI)	P Value		Hazard Ratio (95% CI)	P Value		Hazard Ratio (95% CI)	P Value		Hazard Ratio (95% CI)	P Value	
All deaths	0.60 (0.45-0.67)	<0.0001		1.22 (0.82-1.81)	0.34		0.54 (0.38-0.77)	0.0007		0.43 (0.30-0.62)	<0.0001		0.50 (0.31-0.79)	0.003	
All deaths excluding externally caused**	0.48 (0.38-0.59)	<0.0001		0.89 (0.59-1.34)	0.58		0.43 (0.30-0.60)	<0.0001		0.39 (0.28-0.55)	<0.0001		0.46 (0.31-0.69)	0.0002	
Cardiovascular disease†	0.51 (0.36-0.73)	<0.0001		0.64 (0.29-1.41)	0.27		0.56 (0.29-1.08)	0.08		0.34 (0.16-0.69)	0.003		0.57 (0.28-1.15)	0.12	
Cancer	0.40 (0.25-0.65)	<0.0001		--	--		0.53 (0.22-1.28)	0.16		0.40 (0.19-0.85)	0.02		0.54 (0.21-1.35)	0.19	
All external causes‡	1.58 (1.02-2.45)	0.04		2.53 (1.27-5.07)	0.009		0.86 (0.40-1.87)	0.70		1.32 (0.44-3.97)	0.63		0.76 (0.25-6.86)	0.76	

All hazard ratios adjusted for sex, age, and a cubic polynomial of the baseline BMI.

**Deaths that were caused by disease include all deaths minus those deaths caused by external causes, including accidents unrelated to drugs, poisonings of undetermined intent, suicides, and other externally-caused deaths.

†Coronary artery disease, heart failure, stroke, and other cardiovascular disease.

‡Accident unrelated to drugs, poisoning of undetermined intent, suicide, and other externally-caused deaths.

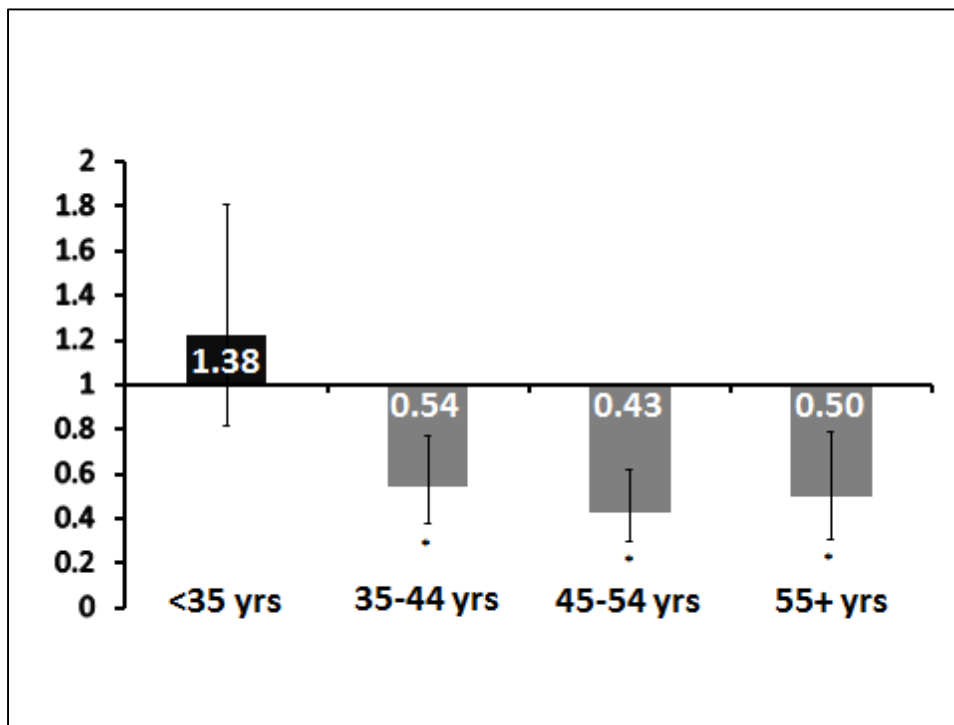

Figure 4.1. Hazard Ratios (HRs) for All-Cause Mortality by Age.

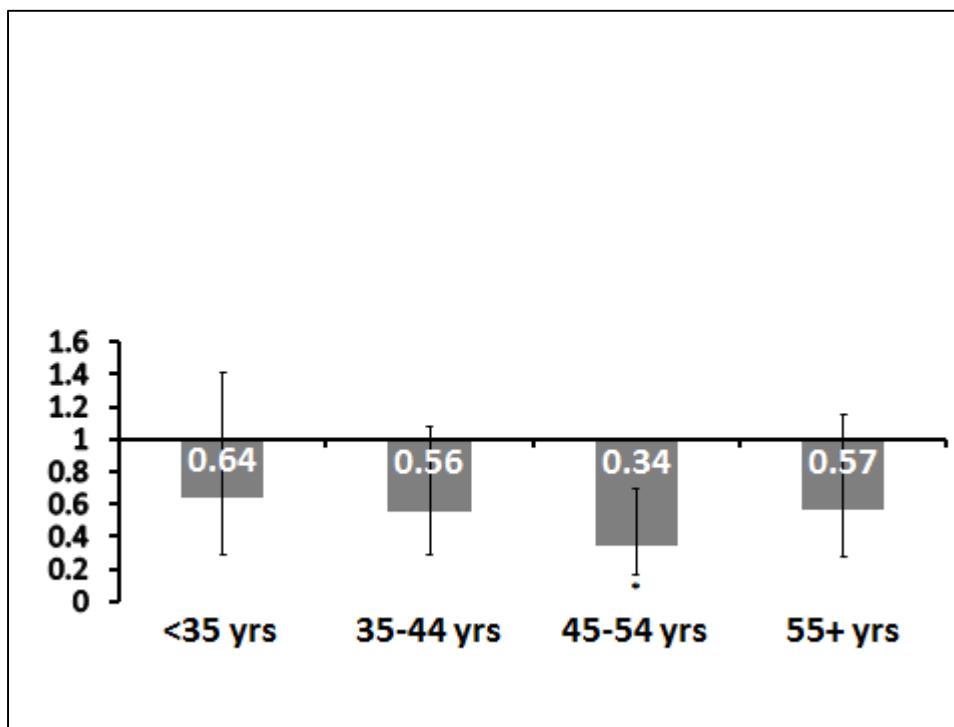

Figure 4.2. Hazard Ratios (HRs) for Cardiovascular Mortality by Age.

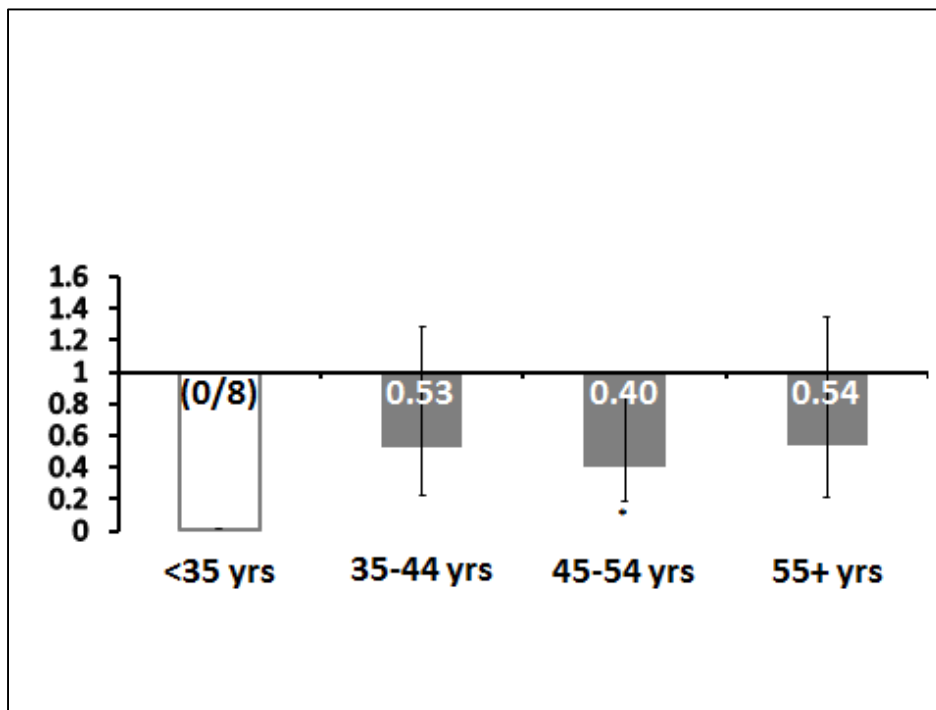

Figure 4.3. Hazard Ratios (HRs) for Cancer Mortality by Age.

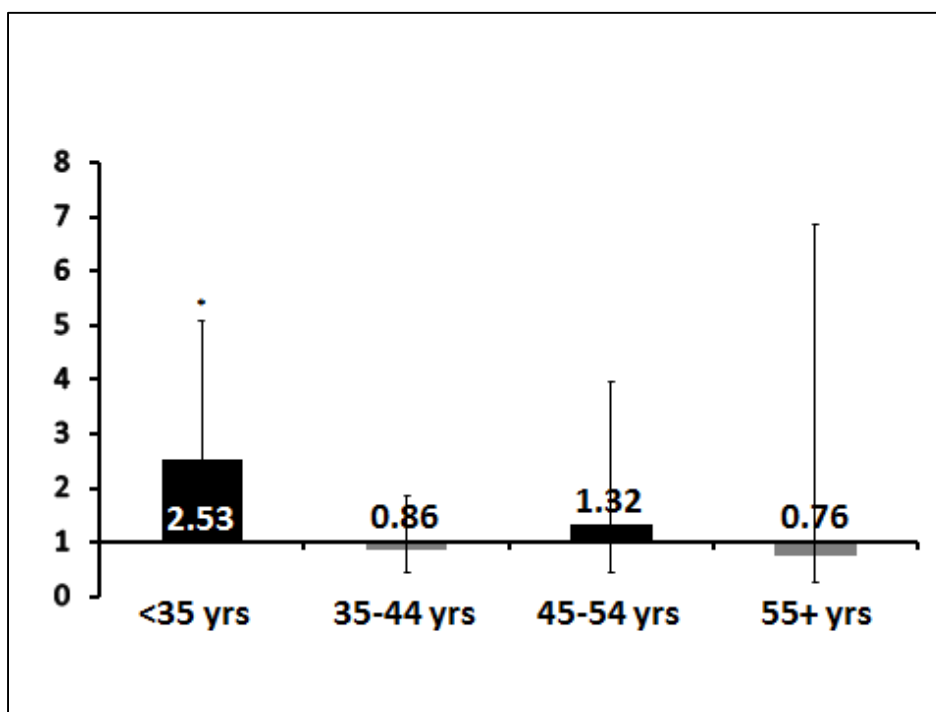

Figure 4.4. Hazard Ratios (HRs) for External Cause Mortality by Age.

Discussion

This study extends a previously published long-term mortality study of patients who have undergone Roux-en-Y gastric bypass surgery as compared to a severely obese population of nonoperated subjects by analyzing all-cause and cause-specific mortality of 4 specific age groups; less than 35 years, 35 to 44 years, 45-54 years, and greater than 55 years. All-cause mortality was significantly lower among all surgical age groups greater than 35 years compared to the nonoperated subjects. While all-cause death was not significantly different between groups for the < 35 years of age category (HR 1.22; 95% CI, 1.22 to 1.81; $p=0.34$), the HR for all external caused deaths for the youngest age category (<35 years) was 2.53 ($p=0.009$) for the surgical patients compared to the nonoperated group. These results would suggest that patients who participate in gastric bypass surgery at a younger age (i.e., less than 35 years) are at a greater risk for death from external causes such as accidents unrelated to drugs, poisonings of undetermined intent, and suicide. Further, study results indicate that gastric bypass surgery is associated with a lower mortality risk for cardiovascular disease- and cancer-related deaths irrespective of age at surgery.

The positive association between all-cause mortality and severe obesity has been well established,[20] with the recent systematic review and meta-analysis of Flegal et al. of more than 2.9 million subjects and 270,000 deaths reporting a hazard ratio of 1.29 (95% CI, 1.18 to 1.41) for all-cause mortality among grades 2 and 3 obesity (i.e., ≥ 35 kg/m²) compared to normal weight BMI (18.5 to less than 25 kg/m²).[21] However, whether or not voluntary weight loss in individuals who are overweight or obese results in reducing all-cause or cause-specific mortality has been less conclusive, with some

epidemiological research reporting a worsened mortality following weight loss.[22] Although somewhat limited, and with some differences in methodological approach, longer term mortality studies of patients who have undergone voluntary weight loss through bariatric surgery have almost without exception reported a reduction in all-cause mortality as well as reduced death rates from certain diseases such cardiovascular disease and cancer.[6-15] From these studies has evolved the clinical message that severely obese patients who are contemplating bariatric surgery can generally expect a longer life if they undergo such surgery. However, at least 2 important clinical questions (or considerations) have arisen with regards to the expected benefit of improved mortality following bariatric surgery.

The first question is whether or not a patient can expect extended life expectancy through reduction of deaths from such illness as cardiovascular diseases and cancer regardless of their age at the time of bariatric surgery, (i.e., do mortality benefits extend to bariatric patients regardless of age at surgery). Shorter term bariatric surgery mortality studies (i.e., greater than 30 days to 2 years following surgery) have suggested patients who undergo surgery at an older age have higher mortality rates.[23-25] In an analysis of 90-day and 1-year postbariatric surgery all-cause mortality of 16,155 Medicare beneficiaries, Flum et al. reported mortality rates were greater for patients 65 years or older when compared with younger patients (6.9% vs 2.3% at 90 days and 11.1% vs. 3.9% at 1 year, $p < 0.001$).[25] Perry et al. conducted a retrospective cohort mortality analysis following bariatric surgery up to 2 years on Medicare fee-for-service patients who had received bariatric surgery ($n=11,903$) compared to one-to-one matching of nonoperated severely obese patients. They reported that bariatric surgical patients had

increased survival rates compared to the nonoperated patients with up to 2 years of follow-up, but noted that the reported survival advantage began 6 months postoperatively for surgical patients under age 65 years and at 11 months for patients over age 65 years.[26] Whether or not a similar, less-favorable mortality outcome for older patients undergoing bariatric surgery persists longer term (i.e., greater than 2 years) when compared to nonoperated BMI matched subjects has only been reported in one study [12] prior to this Utah-based age-stratified report. This single retrospective cohort study of bariatric surgery programs in Veterans Affairs medical centers compared 850 veterans who had undergone bariatric surgery to propensity-matched nonoperated veterans ($n=1694$) using clinical information. The analysis comparing the 2 groups reported bariatric surgery not to be significantly associated with reduced mortality (HR 0.94; 95% CI, 0.64 to 1.39; mean follow-up, 6.7 years).[12] The mean age of the surgical cohort was 49.5 ± 8.3 years and predominantly males (74%) compared to our Utah study of 39.5 ± 10.5 years and only 16% males. In addition, our Utah study did not have access to clinical information other than sex and BMI for use in matching to the nonoperated subjects. Further, Maciejewski et al. reported the veterans to be “sicker patients” compared to other bariatric surgery studies and stated that “it is possible that bariatric surgery reduces mortality for younger patients and not for older male patients.”[12] Contrary to the results of Maciejewski et al., our Utah study reported significantly improved long-term mortality for each of the 3 age groups over age 35 years and in addition, deaths from cardiovascular disease and cancer were significantly lower for postsurgical patients compared to nonoperated subjects for ages 45-54 years, with a similar trend for 35 to 44 years and 55 years and greater.

A second question is whether or not there are specific clinical factors that might predict which bariatric surgical patients are at greater risk for death from non-disease-related deaths such as suicide, poisonings of undetermined intent, and non-drug-related accidents (referred to by the NDI as “external-related deaths”). Importantly, the Utah study has provided an insight to this question by demonstrating that the significant risk for these external causes of death were largely limited to patients who had undergone gastric bypass surgery at less than 35 years of age (i.e., HR 2.53; 95% CI, 1.27 to 5.07; $p=0.009$). In fact, this increase in deaths from external causes among patients whose surgery was performed before the age of 35 years may have accounted for the lack of significantly greater all-cause mortality among this age group. Omalu et al. computed death rates of all bariatric patients in Pennsylvania (1995 to 2004; $n=16,683$ patients; 440 deaths) from the state’s division of vital records.[18] Omitting the bariatric surgical patients, death rates were then derived from the entire Pennsylvania population without regards to BMI. They reported a significantly higher death rate for suicide and drug overdoses of undetermined intent among the surgical patients compared to the general nonoperated population, with most of these deaths having occurred more than one year following bariatric surgery.[18] There are possible contributing reasons for increased externally-caused deaths following some bariatric surgeries. Although limited, observational studies may suggest that some procedures such as gastric bypass may increase the long-term risk for substance use disorders[27-29] and suicide.[30] In an ongoing prospective cohort study being conducted by our Utah group, we have reported that health-related quality of life was significantly more impaired in patients seeking gastric bypass surgery than in non-treatment-seeking participants.[31] Further, at 6-year

follow-up of this study, although health-related quality of life was improved among the surgical group, they did not have an improved SF-36 mental health component.[4] The SF-36 is a widely used psychometric survey used to provide a general assessment of physical and mental health perception.[32] As Livingston has pointed out, there is a “great deal of overlap” between mental health disorders and obesity.[33] In addition to the potential increased risk for substance use disorders, there may exist postsurgical dissatisfaction related to presurgical expectations in comparison with postsurgical outcomes. Clearly, additional research related to the behavioral/psychological aspects before and following bariatric surgery, perhaps especially in the younger aged population, is warranted.

Limitations related to this study included the lack of clinical information prior to or following surgery or drivers license application, with the exception of BMI, age, and sex. As a result, whether or not the gastric bypass patients were of similar health status as the nonoperated subjects prior to surgery or whether or not greater medical attention was provided for postsurgical patients as a result of their surgical entry into the medical system were not known. Potential bias related to self-reported height and weight among the drivers license and ID card applicants may have been present, despite the sex-specific regression correction. Other potential biases related to NDI matching have been previously described.[6] Finally, there were a more limited number of subjects within the greater than 55 years of age group, which may have reduced the power for detecting cause-specific death differences between the surgical patients and nonoperated subjects in this higher age group. Strengths of this study included a rather unique matching design as well as a large number of former gastric bypass patients retrospectively followed for 18

years. The opportunity to divide mortality results into separate age categories was also unique to this study.

Despite limitations, this study implies gastric bypass surgery is protective against cardiovascular and cancer mortality for all age groups. With the exception of increased external causes of death in younger patients (i.e., suicide, poisonings of undetermined intent, and accidents not related to drugs), gastric bypass surgery also significantly reduces all-cause mortality rates, even for patients who undergo surgery at an older age. Further investigations are warranted to better understand and predict risk for externally-caused deaths among post-gastric-bypass patients, especially among surgical patients whose surgery is performed at an earlier age (i.e., less than 35 years).

References

1. Yang, D., et al., *Weight loss causes increased mortality: cons.* *Obes Rev*, 2003. **4**(1): p. 9-16.
2. Sorensen, T.I., *Weight loss causes increased mortality: pros.* *Obes Rev*, 2003. **4**(1): p. 3-7.
3. Sjostrom, L., et al., *Lifestyle, diabetes, and cardiovascular risk factors 10 years after bariatric surgery.* *N Engl J Med*, 2004. **351**(26): p. 2683-93.
4. Adams, T.D., et al., *Health benefits of gastric bypass surgery after 6 years.* *JAMA*, 2012. **308**(11): p. 1122-31.
5. MacDonald, K.G., Jr., et al., *The Gastric Bypass Operation Reduces the Progression and Mortality of Non-Insulin-Dependent Diabetes Mellitus.* *J Gastrointest Surg*, 1997. **1**(3): p. 213-220.
6. Adams, T.D., et al., *Long-term mortality after gastric bypass surgery.* *N Engl J Med*, 2007. **357**(8): p. 753-61.
7. Flum, D.R. and E.P. Dellinger, *Impact of gastric bypass operation on survival: a population-based analysis.* *J Am Coll Surg*, 2004. **199**(4): p. 543-51.
8. Christou, N.V., et al., *Surgery decreases long-term mortality, morbidity, and*

- health care use in morbidly obese patients. Ann Surg, 2004. 240(3): p. 416-23.*
9. Sowemimo, O.A., et al., *Natural history of morbid obesity without surgical intervention. Surg Obes Relat Dis, 2007. 3(1): p. 73-7.*
 10. Busetto, L., et al., *Comparative long-term mortality after laparoscopic adjustable gastric banding versus nonsurgical controls. Surg Obes Relat Dis, 2007. 3(5): p. 496-502; discussion 502.*
 11. Peeters, A., et al., *Substantial intentional weight loss and mortality in the severely obese. Ann Surg, 2007. 246(6): p. 1028-33.*
 12. Maciejewski, M.L., et al., *Survival among high-risk patients after bariatric surgery. JAMA, 2011. 305(23): p. 2419-26.*
 13. Marsk, R., et al., *Antiobesity surgery in Sweden from 1980 to 2005: A population-based study with a focus on mortality. Ann Surg, 2008. 248(5): p. 777-81.*
 14. Zhang, W., et al., *Factors influencing survival following surgical treatment of obesity. Obes Surg, 2005. 15(1): p. 43-50.*
 15. Sjostrom, L., et al., *Effects of bariatric surgery on mortality in Swedish obese subjects. N Engl J Med, 2007. 357(8): p. 741-52.*
 16. Pontiroli, A.E. and A. Morabito, *Long-term prevention of mortality in morbid obesity through bariatric surgery. A systematic review and meta-analysis of trials performed with gastric banding and gastric bypass. Ann Surg, 2011. 253(3): p. 484-87.*
 17. Kwok, C.S., et al., *Bariatric surgery and its impact on cardiovascular disease and mortality: A systematic review and meta-analysis. Int J Cardiol, 2014. 173(1): p. 20-28.*
 18. Omalu, B.I., et al., *Death rates and causes of death after bariatric surgery for Pennsylvania residents, 1995 to 2004. Arch Surg, 2007. 142(10): p. 923-8; discussion 929.*
 19. Horm, J., *Assignment of probabilistic scores to National Death Index record matches, in National Death Index Plus: Coded Causes of Death, R. Bildgrad, Editor. 1996, Division of Vital Statistics, National Center for Health Statistics, CDC: Hyattsville. p. A5-A12.*
 20. McTigue, K., et al., *Mortality and cardiac and vascular outcomes in extremely obese women. JAMA, 2006. 296(1): p. 79-86.*
 21. Flegal, K.M., et al., *Association of all-cause mortality with overweight and*

- obesity using standard body mass index categories: A systematic review and meta-analysis.* JAMA, 2013. **309**(1): p. 71-82.
22. Bray, G.A., *The missing link - lose weight, live longer.* N Engl J Med, 2007. **357**(8): p. 818-20.
 23. Arterburn, D., et al., *Predictors of long-term mortality after bariatric surgery performed in Veteran Affairs medical centers.* Arch Surg, 2009. **144**(10): p. 914-920.
 24. Buchwald, H., et al., *Trends in mortality in bariatric surgery: A systematic review and meta-analysis.* Surgery, 2007. **142**: p. 621-35.
 25. Flum, D.R., et al., *Early mortality among Medicare beneficiaries undergoing bariatric surgical procedures.* Jama, 2005. **294**(15): p. 1903-8.
 26. Perry, C.D., et al., *Survival and changes in comorbidities after bariatric surgery.* Ann Surg, 2008. **247**(1): p. 21-27.
 27. King, W.C., et al., *Prevalence of alcohol use disorders before and after bariatric surgery.* JAMA, 2012. **307**(23): p. 2516-25.
 28. Ostlund, M.P., et al., *Increased admission for alcohol dependence after gastric bypass surgery compared with restrictive bariatric surgery.* JAMA, 2013. **148**(4): p. 374-7.
 29. Svensson, P.A., et al., *Alcohol consumption and alcohol problems after bariatric surgery in the Swedish Obesity Subjects study.* Obesity, 2013. **21**(12): p. 2444-51.
 30. Peterhansel, C., et al., *Risk of completed suicide after bariatric surgery: A systematic review.* Int Assoc Study of Obes, 2013. **14**(5): p. 369-82.
 31. Kolotkin, R.L., R.D. Crosby, and G.R. Williams, *Health-related quality of life varies among obese subgroups.* Obes Res, 2002. **10**(8): p. 748-56.
 32. Ware, J.E.J., *SF-36 Health Survey: Manual and Interpretation Guide.* 1993, Boston: The Health Institute, New England Medical Center.
 33. Livingston, E.H., *Invited critique.* Arch Surg, 2007. **142**(10): p. 929.

CHAPTER 5

CONCLUSION

As indicated in the introductory comments of this dissertation, weight loss surgery has as its primary aim significant and sustained weight loss for the severely obese population. The estimated number of bariatric surgeries performed worldwide in 2011 was 340,768,[1] and in the U.S., the most commonly performed bariatric surgery is the Roux-en-Y gastric bypass (RYGB) (Figure 1.1b).[2, 3] As highlighted, this operation, now primarily performed laparoscopically, reroutes the normal gastrointestinal tract (see Figure 1.1a) as the stomach and the first segment of the small intestine, the duodenum, are bypassed (Figure 1.1b). A small proximal cardia pouch of the stomach (10-30 mL) is formed to receive ingested foods (Figure 1.1b).

A systematic review and meta-analysis of several randomized control trial studies (RCTs)[4] has reported on the short-term (one to 2 years) clinical outcomes of patients who have undergone RYGB surgery,[5-7] and other bariatric surgical procedures (adjustable gastric banding (AGB), vertical sleeve gastrectomy, and biliopancreatic diversion)[6-9]. Results demonstrated significantly greater weight loss (short-term), with a reported mean difference of -26 kg (95% CI, -31 to -21; $p < 0.001$) as well as a greater type 2 diabetes mellitus (T2DM) remission, with a reported relative risk (RR) of 22.1 (95% CI, 3.2 to 154.3; $p < 0.002$) for the complete case analysis when compared to

nonsurgical participants.[10] In addition, high-density cholesterol (HDL-C) and triglycerides were significantly improved among the surgical groups, and although medications for hypertension and other lipids were not shown to be significantly different between groups, some studies did report fewer use of medication for these conditions.[4, 10]

Two long-term prospective controlled intervention studies (non-RCTs) have been published, one a Utah study (6 years follow-up) including exclusively RYGB patients [11] and the other a Swedish Obesity Subjects (SOS) study (15 years follow-up) including RYGB (13%), AGB (19%) and vertical gastric banding (68%; procedure no longer performed)[12]. Remarkably, in the SOS surgical group, there was a 72% remission of T2DM at 2 years follow-up (OR 8.4, 95% CI 5.7 to 12.5; $p<0.001$) and at 10 years follow-up, the T2DM remission was 36% (OR 3.5, 95% CI 1.6 to 7.3; $p<0.001$).[10, 12] In the Utah study, weight loss in the RYGB group was 34.9% (95% CI, 33.9% to 35.8%) from baseline to year 2 and 27.7% (95% CI, 26.6% to 28.9%) from baseline to year 6. Weight gain for the control groups from baseline to year 6 was 0.2% (95% CI, -1.1% to 1.4%) and 0% (95% CI, -1.2% to 1.2%).[11] Diabetes remission at year 2 examination was 75% (95% CI, 63% to 87%), decreasing to 62% (95% CI, 49% to 75%) at year 6. Further, the RYGB group had a 5- to 9-fold reduction in the risk of developing new diabetes when compared to the control groups.[11] As dramatic as the remission rate for diabetes following RYGB is, an equally impressive finding is rapid remission of diabetes within 2 days to 2 weeks after RYGB – long before significant weight loss,[13, 14] suggesting factors independent of weight loss are responsible for the rapid remission of diabetes.

Similar to the SOS study, our Utah study showed all major CVD risk factors (lipids, blood pressure, glucose, insulin, HbA1c) were significantly improved in the surgical group when compared to the 2 control groups.[11] Reported remission rates of hypertension (6 years) were significantly improved in the surgical versus control group (42%, [95% CI, 32-52%] versus 18%, [95% CI 9-27%], OR, 2.9 [95% CI, 1.4-6.0] and 42% versus 9%, [95% CI 3-15%], OR, 5.0 [95% CI, 2.1-11.9]). Further, the remission of low HDL-C rates were improved in the RYGB compared with control groups (67% [95% CI, 57-77%] versus 34%, [95% CI, 23-45%], OR, 3.8 [95% CI, 2.0-7.2] and 67% versus 18%, [95% CI, 8-28%], OR, 6.2 [95% CI, 2.7-14.1]), and similar remission rates were reported for LDL-C and triglycerides.[11]

The SOS study and a long-term retrospective controlled Utah study have also reported improved mortality for patients who have had bariatric surgery when compared to severely obese, nonoperated matched controls. The Utah study compared all-cause and cause-specific mortality for 7,925 RYGB patients compared to 7,925 weight- and age-matched controls (1984-2002; average follow-up of 7.1 years) and reported a 40% reduction in all-cause mortality (HR 0.60; 95% CI, 0.45 to 0.67; $p < 0.001$).[15] Similarly, the SOS study reported a 29% lower all-cause mortality (HR 0.71; 95% CI, 0.54 to 0.92; $p < 0.01$) among the bariatric surgical group compared to matched controls after a 16-year total follow-up.[16]

Finally, an on-going multicenter observational cohort study (NIH-funded) at 10 US hospitals, referred to as the Longitudinal Assessment of Bariatric Surgery (LABS) Consortium, has recently published their 3-year follow-up results.[17] Of the 2,458 study patients, 1,738 (71%) underwent RYGB and at 3 years postsurgery, the median percent

weight loss was 31.5% (IQR, 24.6% to 38.4%; range, 59.2% loss to 0.9% gain) of baseline weight. The RYGB patients who had at least partial diabetes remission was 67.5%, whereas remission of hypertension and dyslipidemia were 38.2% and 61.9%, respectively.[17]

International experts attending the National Institutes of Health (NHLBI and NIDDK) recently convened to explore long-term outcomes following bariatric surgery (Bethesda, Maryland, May 2013) have identified a major knowledge gap in bariatric surgery is being able to identify factors (and patients) that might predict the long-term durability (success) of the surgery. Unfortunately, important metabolic measures related to metabolism (i.e., resting metabolic rate) and cardiorespiratory fitness have not been reported to date in relation to long-term weight changes following RYGB surgery. In addition, limited research relating to pregnancy outcomes in women who have participated in bariatric surgery has been reported and the association of age at RYGB surgery with long-term mortality has not been published. The aims of this study focused on addressing these potential predictive factors.

As anticipated, the findings of the 3 proposed aims of this study did reveal specific outcomes that are likely to have predictive clinical value. The results of Aim 1 demonstrated that favorable changes in CRF following RYGB surgery (i.e., from year 2 to year 6) can have a positive influence upon reducing the risk of long-term weight regain following surgery (i.e., from year 2 to year 6). These findings also support clinical guidelines that recommend patients undergoing bariatric surgery should be well-informed of the importance to build in a lifetime of participation in physical activity following surgery. Pursuing clinical outcomes of pregnancy among women who have and have not

undergone gastric bypass surgery, Aim 2 clearly demonstrated that following Roux-en-Y gastric bypass (RYGB) surgery, women are at a significantly reduced risk for having a large-for-gestational-age (LGA) live birth. The results also indicated that post-RYGB surgery mothers are at a significantly greater risk to deliver a small-for-gestational-age (SGA) neonate. The increased risk for SGA delivery raises considerable clinical concern related to potential nutritional deficiencies for both the mother and the developing fetus. Greater exploration related to mechanisms that may account for the increased SGA risk following RYGB surgery as well as clinical surveillance of these SGA-born neonates during childhood, adolescence, and adulthood to determine long-term SGA outcomes are warranted. Finally, results of Aim 3 provided strong implication that gastric bypass surgery is protective against cardiovascular and cancer mortality for age groups greater than 34 years. With the exception of increased external causes of death in patients less than 35 years (i.e., suicide, poisonings of undetermined intent, and accidents not related to drugs), gastric bypass surgery also significantly reduces all-cause mortality rates, even for patients who undergo surgery at an older age. Further investigations are warranted to better understand and predict risk for externally-caused deaths among postgastric bypass patients, especially among surgical patients whose surgery is performed at an earlier age (i.e., less than 35 years).

References

1. Buckwald, H. and D.M. Oien, *Metabolic/bariatric surgery worldwide*. *Obes Surg*, 2013. **23**(4): p. 427-436.
2. Livingston, E.H., *Procedure incidence and in-hospital complication rates of bariatric surgery in the United States*. *Am J Surg*, 2004. **188**(2): p. 105-10.
3. Santry, H.P., D.L. Gillen, and D.S. Lauderdale, *Trends in bariatric surgical*

- procedures*. JAMA, 2005. **294**(15): p. 1909-17.
4. Gloy, V.L., et al., *Bariatric surgery versus nonsurgical treatment for obesity: a systematic review and meta-analysis of randomised controlled trials*. BMJ, 2013. **347**: p. f5934.
 5. Ikramuddin, S., et al., *Roux-en-Y gastric bypass vs intensive medical management for the control of type 2 diabetes, hypertension, and hyperlipidemia: the Diabetes Surgery Study reandomized clinical trial*. JAMA, 2013. **309**(21): p. 2240-2249.
 6. Mingrone, G., et al., *Bariatric surgery versus conventional medical therapy for type 2 diabetes*. N Engl J Med, 2012. **366**(17): p. 1577-85.
 7. Schauer, P.R., et al., *Bariatric surgery versus intensive medical therapy in obese patients with diabetes*. N Engl J Med, 2012. **366**(17): p. 1567-76.
 8. Dixon, J.B., et al., *Adjustable gastric banding and conventional therapy for type 2 diabetes: a randomized controlled trial*. JAMA, 2008. **299**(3): p. 316-23.
 9. O'Brien, P.E., et al., *Treatment of mild to moderate obesity with laparoscopic adjustable gastric banding or an intensive medical program: a randomized trial*. Ann Intern Med, 2006. **144**(9): p. 625-33.
 10. Arterburn, D.E. and A. Courcoulas, *The efficacy and safety of bariatric surgery for obesity and metabolic conditions in adults: a state of the art review*. BMJ, 2013. Accepted for Publication.
 11. Adams, T.D., et al., *Health benefits of gastric bypass surgery after 6 years*. JAMA, 2012. **308**(11): p. 1122-31.
 12. Sjostrom, L., et al., *Lifestyle, diabetes, and cardiovascular risk factors 10 years after bariatric surgery*. N Engl J Med, 2004. **351**(26): p. 2683-93.
 13. Thaler, J.P. and D.E. Cummings, *Minireview: Hormonal and metabolic mechanisms of diabetes remission after gastrointestinal surgery*. Endocrinology, 2009. **150**(6): p. 2518-25.
 14. Hickey, M.S., et al., *A new paradigm for type 2 diabetes mellitus: could it be a disease of the foregut?* Ann Surg, 1998. **227**(5): p. 637-43.
 15. Adams, T.D., et al., *Long-term mortality after gastric bypass surgery*. N Engl J Med, 2007. **357**(8): p. 753-61.
 16. Sjostrom, L., et al., *Effects of bariatric surgery on mortality in Swedish obese subjects*. N Engl J Med, 2007. **357**(8): p. 741-52.
 17. Courcoulas, A.P., et al., *Weight change and health outcomes at 3 years after*

bariatric surgery among individuals with severe obesity. JAMA, 2013. **310**(22):
p. 2416-2425.