



CHALMERS
UNIVERSITY OF TECHNOLOGY

Autonomous corner modules as an enabler for new vehicle chassis solutions

Downloaded from: <https://research.chalmers.se>, 2020-01-17 16:25 UTC

Citation for the original published paper (version of record):

Jonasson, M., Zetterström, S., Stensson Trigell, A. (2006)

Autonomous corner modules as an enabler for new vehicle chassis solutions

FISITA Transaction, 2006(F2006V054T)

N.B. When citing this work, cite the original published paper.

AUTONOMOUS CORNER MODULES AS AN ENABLER FOR NEW VEHICLE CHASSIS SOLUTIONS

^{1,2}Jonasson, Mats*, ¹Zetterström, Sigvard, ²Stensson Trigell, Annika
¹Volvo Car Corporation, Sweden, ²KTH Vehicle Dynamics, Sweden

KEYWORDS – Chassis control, vehicle dynamics, steering, propulsion, active suspension.

ABSTRACT – Demands for new functions and refined attributes in vehicle dynamics are leading to more complex and more expensive chassis design. To overcome this, there has been increasing interest in a novel chassis design that could be reused in the development process for new vehicle platforms and mainly allow functions to be regulated by software. The Autonomous Corner Module (ACM) was invented at Volvo Car Corporation (VCC) in 1998. The invention is based upon actively controlled functions and distributed actuation. The main idea is that the ACM should enable individual control of the functions of each wheel; propulsion/braking, alignment/steering and vertical wheel load. This is done by using hub-motors and by replacing the lower control arm of a suspension with two linear actuators, allowing them to control steering and camber simultaneously. Along with active spring/damper and wheel motors, these modules are able to individually control each wheel's steering, camber, suspension and spin velocity. This provides the opportunity to replace mechanical drive, braking, steering and suspension with distributed wheel functions which, in turn, enable new vehicle architecture and design.

The aim of this paper is to present the vehicle dynamic potential of the ACM solution, by describing its possible uses and relating them to previous research findings. Associated work suggests chassis solutions where different fractions of the functions of the ACM capability have been used to achieve benefits in vehicle dynamics. For instance, ideas on how to use active camber control have been presented. Other studies have reported well-known advantages, such as, good transient yaw control from in-wheel motor propulsion and stable chassis behaviour from four-wheel steering, when affected by side wind. However, this technology also presents challenges. One example is how to control the relatively large unsprung mass that occurs due to the extra weight from the in-wheel motor. The negative influence from this source can be reduced by using active control of vertical forces. The implementation of ACM, or similar technologies, requires a well-structured hierarchy and control strategy. Associated work suggests methods for chassis control, where tyre forces can be individually distributed from a vehicle path description. The associated work predominately indicates that the ACM introduces new opportunities and shows itself to be a promising enabler for vehicle dynamic functions.

1 INTRODUCTION

In general, components in modern chassis design can rarely be reused in the development process of new vehicle platforms. This is due to the implementation of functions involving great amounts of hardware. Therefore, new vehicle dynamic functions can involve a great deal of redesign work, even for small modifications. As a result, there has been increasing interest in new chassis solutions where attributes are determined by software implementations. Furthermore, there has been an increasing interest in new functions that cannot be developed using the conventional chassis. Chassis design is also becoming more technically complex due to the fact that the conventional chassis has many constraints. As a result, there have been many studies about designing and controlling a chassis with a limited degree of freedom. However, little attention has been devoted to chassis with many degrees of freedom as concerns geometry and kinematics where tyre forces can be freely controlled.

Given this situation, there is considerable interest in a novel chassis design where functions are mainly software-implemented, and tyre forces are allowed to be freely distributed.

One chassis solution that is a vital contribution to these demands, was invented at Volvo Car Corporation (VCC) in 1998. Originally, this invention was an outcome of a study at VCC of a vehicle where steering linkage and drive shafts could not be connected mechanically due to the very elastic car body design. The design criteria and demands on limited packaging space were followed by a rough wheel unit concept, which was later refined in the Autonomous Corner Module (ACM) (1, 2). The name "autonomous" indicates that wheel forces and kinematics are individually controlled supporting a common task. Similar inventions including *all* features have not yet been produced, either as concept cars or in series production, even though some chassis components, such as, wheel motors have been used for more than 100 years. In general most components are widely used (not always in vehicle applications) but not fitted to enable intense actuation close to the wheels.

This paper presents the idea of the ACM and covers associated work and research done in this area of technology. More specifically, the aim is to describe the ACM as an enabler for new chassis functions. The paper can be outlined as follows: Section 2 briefly describes the design of the ACM. Sections 3 to 7 provide a description of camber control, propulsion, steering control, active vertical force use and alleviating the chassis constraints. Sections 8 and 9 discuss path control strategies and hierarchy respectively. Finally, the conclusions are presented in Section 9.

2 ACM DESIGN

The initial ACM invention is based upon the wheel hub being actively guided at three points on the car body, one upper point to control the wheel force vertically and two at the bottom to provide steering and camber (1, 2). The upper guiding controls the vertical load and takes care of the suspension and damping function apart from the static vehicle weight, for which an ordinary spring is required. The two lower guidings, replacements of the lower control arm and steering/track rod in a conventional wheel suspension, are connected to linear actuators and move transversely. To eliminate actuator side forces (i.e. forces acting in the same direction as the longitudinal tyre forces) and avoid impact from longitudinal vehicle forces, a complementary arm has been added between the actuators, as shown in a later design proposal (Figure 1). The concept of the transverse linear actuation has been examined in a Master thesis at VCC (3, Figure 2) which resulted in the drivable concept car (4), where two

hydraulic actuators were positioned at each rear wheel to enable camber and steering control at the rear axle.

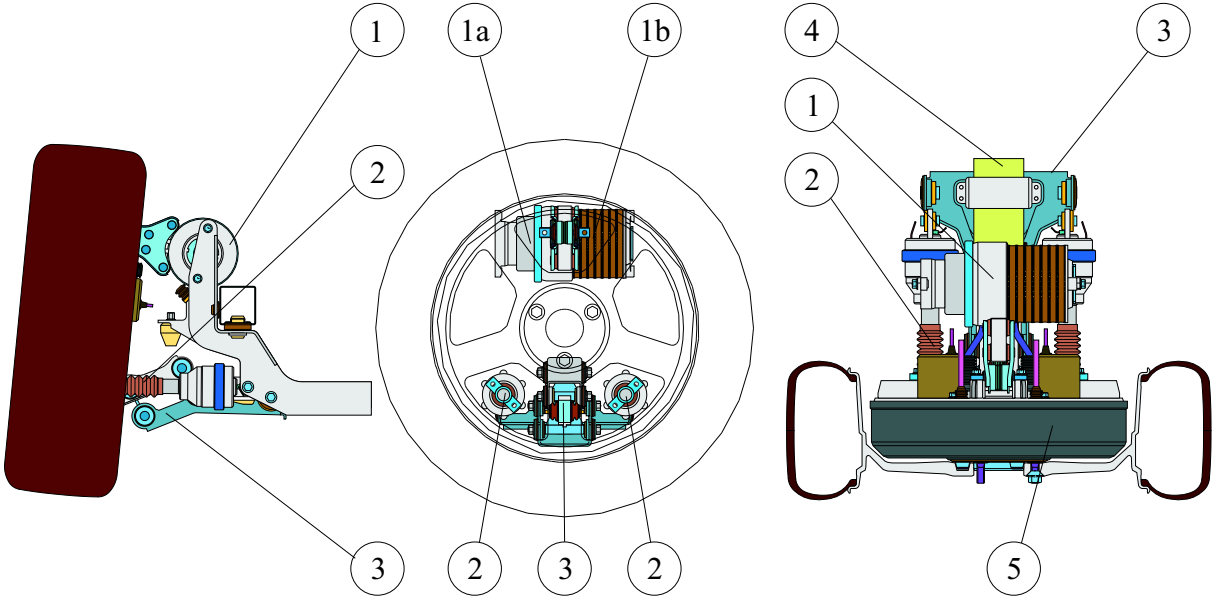

Figure 1. Design proposal for the ACM, showing front, side and top views.

- 1. Damper (1a) with adjustable spring (1b)
- 2. Steering actuators
- 3. Lower arm
- 4. Leaf spring
- 5. In-wheel motor

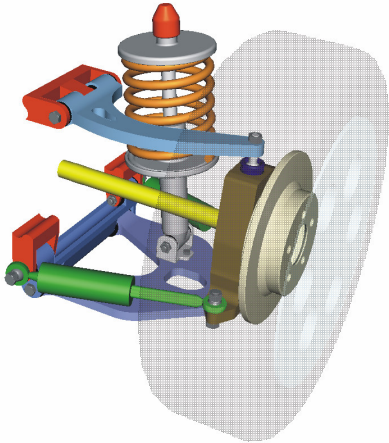

Figure 2. Wheel suspension using two actuators for steering and camber (3, 4).

3 CAMBER CONTROL

The ACM enables individually controlled camber angles by changing the length of the lower actuators in the same direction. The arguments for implementing camber control can mainly be summarised as follows:

- Tyre wear reduction (adjustability gives better tyre patch)
- Directional stability improvement
- Vehicle track width adjustment
- Maximum lateral force increased
- Tyre to road contact zone alignment, by rolling the tyre to an area where low rolling resistance, adhesion or other properties are better fulfilled
- Risk of aquaplaning reduced
- Understeer gradient adjustment
- Tyre slip reduced during turning manoeuvres

Some of the afore-mentioned arguments are in conflict with each other. Consider the following example; it is not always possible to minimise rolling resistance and at the same time maximise the ability to generate lateral force. However, the use of camber control implies the challenge to achieve a good balance between the items listed. Changing vertical displacement tends to change the camber angle in conventional wheel suspensions, leading to an increase in tyre wear. Nevertheless, for modern radial tyres, wear is only important when the camber angle exceeds 1° (5, 6). Furthermore, to prevent roll-critical incidents, the negative camber control could be used to increase track width. Larger track width also means reduced load transfer between outer and inner wheel when lateral acceleration is present. The centre of gravity can be lowered using negative camber depending on the wheel suspension and tyre geometry. If this effect is unwanted, then systems for active vertical force combined with camber control may be needed to adjust the car body height to a desired level.

The Mercedes F400 concept car, the Carving Car, (7) was developed to utilise benefits of camber control. The vehicle could vary the negative camber up to 20° , which is a much better performance than most other wheel suspension geometry available. The name of the vehicle, "Carving", is related to the way modern alpine skis are used. When cornering, the outer wheels are tilted "top inwards", i.e. negative camber, and another area with high adhesion tyre tread is used. This is useful during an evasive manoeuvre or when entering a curve at high speed while still maintaining vehicle stability. The cambered wheel increases the maximum possible lateral force from 6200 N at 0° camber to 7800 N at 20° camber. Consequently, the F400 Carving Car could perform up to 28% higher lateral acceleration than would be expected for car with a conventional wheel suspension. Figure 3 illustrates a vehicle utilising negative camber angles to reach high lateral acceleration. In addition, negative camber can be used to shorten braking distance where the vehicle uses the high adhesion area on all wheels. As a result, the F400 Carving car increases the maximum longitudinal force by 15% as compared to a conventional vehicle with standard tyres. Even if the tyre is not provided with two or more tread areas, camber could be used to increase lateral force. In particular, an additional lateral force can be obtained by combining tyre side slip and camber when the lateral tyre force is maximised and saturated using a high tyre side slip angle. Moreover, when there is a risk of aquaplaning a change in camber angle could be used to optimise the tyre contact patch. The study of the Carving car when using Carving tyres shows a substantially reduced risk of aquaplaning when the camber angle is changed to 5° .

4 PROPULSION

Vehicle chassis design has been characterised by a *central* generation of forces where the actuations take place far removed from where they are supposed to act. Internal combustion engines generate propulsion forces inside the vehicle rather than directly at the tyre. Another example is steering systems using power assist where force needs to be transferred via a

steering rack to the tyre. In opposition to this, *local* generation of forces close to the tyre is presumably opening up further developments for chassis systems where more functions can be covered. In turn, this may cause new problems. One of these is the *redistribution* of masses. Despite using a lightweight vehicle with a similar ACM technology the wheel becomes heavier because of the added weight of the in-wheel motor. However, if regenerative braking is applied the weight of the brakes, which is a large part of the total weight of the wheel, can be reduced. This is possible due to the lowered demands on the friction brake, since regenerative braking contributes to a high proportion of the total brake force needed.

The recently developed electric in-wheel motors for automotive use are available with a power-weight ratio of approximately 1 kW/kg (nominal). On the other hand, in-wheel motors may be hydraulic to ensure small and compact packaging size. However, hydraulic actuators do not offer an energy-efficient solution, unlike the electric one, which is well adapted for installation in vehicles where electricity is the main or secondary energy source. Thus, electric in-wheel motors are suitable for electric vehicles due to regenerative braking and the possibility of controlling power and energy flow.

The in-wheel motor benefits from quick torque response and ability to allocate wheel torque individually. This allocation can be used for controlling the yaw moment and is often referred to as Direct Yaw Control (8-10). The torque from the in-wheel motors is used to generate a yaw moment around the vehicle, to improve the transient response when cornering and when yaw moment is required to stabilise the vehicle. A reduction of time delay by 10-30% when entering a curve and by 40% for pure lateral movements has been reported (11).

5 STEERING CONTROL

Individual four-wheel steering is a known method of improving manoeuvrability at low speed and vehicle stability at high speed. At high speed, the response can be improved by steering the rear wheels in the same direction as the front wheels. During low speed, manoeuvres, such as parking, the rear wheels are normally steered in the opposite direction, reduce the turning radius. However, this paper does not describe steering at low speeds.

In contrast to the front-steered vehicle, the four-wheel-steered vehicle is able to generate lateral forces at the front axle *and the rear axle* even if the vehicle side slip vanishes. This is possible because of the ability to individually control wheel steering angles at the front and rear axles and consequently the tyre side slip angles. The control of lateral force generation at front and rear axles indicates two important advantages; robustness against lateral disturbance and improved response.

Four-wheel-steered vehicles can be used to further increase robustness against disturbance affecting the vehicle yaw movement. Side wind and trailers are common sources that excite the car body and thus reduce vehicle stability. The response to such disturbances for conventional front-steered vehicles is a yawing movement, where the driver needs to put in a great deal of effort to steer to compensate for tracking error. One method to overcome this situation is to adapt steering on the rear wheels combined with front-wheel steering. One possible solution is presented in (12) where the aim is to reduce the affect of side wind. The key factor was to use a differential pressure sensor to measure the disturbance from side wind. The front wheel angles are directly controlled by the driver via the steering wheel, while the rear wheel angles are directly controlled via the yaw speed and the moment arising from the side wind pressure. Later on, the algorithm was tested in a prototype vehicle where the

influence of side wind disturbance on yaw speed and steering work could be reduced considerably.

Four-wheel-steered vehicles can also be used for improved response. The time lag between steering action and force generation at the rear wheels can in practice be eliminated, which can be used to reach steady state more rapidly (13,14). The overall capabilities of collision avoidance may be improved. In particular, the vehicle can change lateral position without changing heading angle.

One common approach for controlling the wheel angles in the four-wheel-steered vehicle is based on measurements of the steering wheel angle and steering wheel angle velocity and sometimes the vehicle velocity. In (14) numerous algorithms are presented for controlling the wheel angles in order to improve the response. The simplest one calculates the rear wheel angles directly proportional to the steering wheel. Advanced rear four-wheel steering is used to increase the yaw speed rapidly firstly by steering the rear wheels in the opposite direction and later on by steering them in the same direction. The magnitude of the opposite phase is dependent on steering wheel speed. To further increase the yaw response, a front and advanced rear four-wheel steering can be used.

6 ACTIVE VERTICAL FORCE

In spite of the use of lightweight components in the ACM the in-wheel motor will add weight to the unsprung mass, which becomes larger than an ordinary wheel. High unsprung mass reduces the natural frequency of the wheel shifting the transfer of disturbances arising from road irregularities to lower frequencies. Consequently, the vertical acceleration of the rigid car body increases, which undermines the comfort of the vehicle.

Another effect of high unsprung mass is increased oscillations of the normal tyre force. To gain high performance, the aim is to keep high contact forces between road and tyre when good grip is needed and simultaneously maintain low vertical acceleration of the car body. However, during conditions when good grip is not necessary, the tyre contact forces may be low, thus reducing the rolling resistance of the vehicle.

To overcome the negative effects of unsprung mass, active control of the vertical load may be needed. The ACM is provided with a torsional spring and a rotational damper to be able to actively vary the vertical load and damping coefficient to suppress these negative effects. The torsional spring controls pitch and roll movements and is regulated to keep a specific level of car body above ground. Damping control could, for instance, be implemented by a magnetorheological (MR) fluid where the internal friction of the fluid could be controlled by a magnetic field when the fluid is passed through a valve. The MR alternative is preferable because of the relatively low power consumption and the ability to apply a wide range of damping force, even during a variety of velocities. A 43% reduction of the vertical acceleration using a fuzzy logic control algorithm for an MR semi-active damper is presented in (15). In (16) the energy dissipation in a magnetorheological damper is elaborated. The energy dissipated in a MR damper is low compared to the energy supplied. However, by utilising an electromagnetic actuator as a "damper" the suspension system could be designed to work in all four quadrants adding the advantage of energy regeneration (17). The actuator then works as a generator during the damping cycle and as a motor during actuation. Thus, fulfilling all requirements for active suspension.



Figure 3. An illustration of a cornering manoeuvre of a vehicle with an ACM chassis (the vehicle is turning left at high speed). Negative camber angles of outer wheels and individual steering of the wheels combined can be used to obtain high lateral acceleration. Note the vertical force intervention lowering the left side of the vehicle body and tilting it in toward the curve to achieve desired comfort (18).

7 ALLEVIATING THE CHASSIS CONSTRAINTS

Even the most modern type of conventional chassis control is highly limited by mechanical restrictions reducing the degrees of freedom of the wheels. Wheel movements and the ability of tyres to generate forces are not completely individually controlled in the conventional chassis. Consider the following example: Ordinary differentials on drive shafts cancel the utilisation of freely distributed propulsion torque. Another illustration is front wheel steering where individual steering angles of the wheels can not be individually controlled. However, there is a trend to replace ordinary chassis systems with other types where the number of constraints can be reduced. One example is the active E-differential which allows propulsion torque to be arbitrarily distributed between the left and right sides of the vehicle. There is a definite need for controlling the tyre forces more easily, which has been indicated during the development of vehicle dynamics, and striving for better vehicle performance.

Chassis systems with few constraints, such as the active E-differential, are mainly developed to act independently and assign advantages of a specific category. Therefore, a number of systems can be integrated into the vehicle to offer the total desired categories needed where each system releases constraints of tyre force distribution. Individual brake intervention, additional rear steering and super-imposed front steering are examples of typical independent chassis systems. These systems have been evaluated working independently and when combined with each other (19). The authors show that none of these systems can cover all desired categories; vehicle handling, road holding abilities, stability and longitudinal dynamics, but if they acted in combination with one another and also independently, then all categories would be better assigned. However, combining them can result in negative interference where one specific category deteriorates. To further improve the assignment to all categories and avoid negative interference, the authors conclude that it is better to use a combination of systems with a functional connection between them.

8 VEHICLE CONTROL USING ACM

This section briefly presents associated work about controlling the path of a vehicle where tyre forces can be individually allocated. Global forces and torque, which are calculated from path requirements, are allocated to each corner of the vehicle. Inverse models for actuators and tyres convert these corner forces to desired in-wheel motor torques and steering angles.

8.1 Tyre force intervention from vehicle path requirements

In (20-22) a novel approach is used to control a vehicle with individual steering, propulsion/braking and vertical load. The vehicle is considered to follow a specific plane path in the vehicle's fixed-coordinate system, completely determined by longitudinal speed v , vehicle slip angle β and curvature ρ . This representation is applicable for a wide range of vehicle speed and specially for low speed manoeuvres. The desired path $\{v, \beta, \rho\}$ is a result of driver intentions or more precisely, a result of driver control action. In order to move the vehicle along the desired path, computation of the desired global forces and torque $\{F_x, F_y, M_z\}$ acting on the centre of gravity is possible, when considering the vehicle as a rigid body with a specified mass and moment of inertia.

Given the global forces and torque, the local forces at each corner of the vehicle can be allocated. The tyre forces in the contact patch are composed of longitudinal and lateral forces which are finally determined by mapping the vehicle corner forces to the wheel coordinate system. This is determined by the actual wheel steering angle. However, allocation can be done in many ways, since infinite combinations of wheel unit forces result in identical car body forces. Accordingly, the allocation of wheel forces results in an under-determined set of equations. One approach to solving the equations is: Add cost functions and constraints.

Adding cost functions will increase the rank of the equations. An example of a cost function, as in (23), is the generation of the total vehicle yaw moment M_z where cost for longitudinal and lateral corner forces are determined respectively. Low cost for longitudinal corner forces results in high utilisation of in-wheel motor torque, rather than utilising steering when high vehicle yaw moment is requested.

Normal tyre forces can be allocated to each tyre fulfilling a set of requested global forces and torques $\{F_y, M_x, M_y\}$ in a similar manner as the allocation of longitudinal and lateral tyre forces. These are determined by the desired total vertical, roll and pitch movements.

Naturally, there are constraints on the level of forces each ACM can generate. These are determined by the tyre and the actuators controlling the ACM. Longitudinal and lateral tyre forces are affected and limited by the friction at the contact patch and the vertical tyre force in question. Thus, one very important aspect of allocation is to utilise the available friction at the contact patch between tyre and ground, or more generally, to allocate forces in order to secure that all tyres are within the force limits. Further development of *adhesion potential* can be found (24) where the ratio between actual tyre forces and maximum tyre forces is minimised for all tyres. Allocations of this type, and generally, when the adhesion at each wheel has to be exploited, require friction coefficient estimates. Examples of solutions to the under-determined equations are found in (21), where an optimisation algorithm of the least square type is used to allocate the wheel corner forces and in (22), where a pseudo-inverse method is adapted.

8.2 Inverse tyre and actuator models

The set of vehicle corner forces must be converted to a set of total wheel torques and tyre slip angles. In (23) an inverse tyre model is suggested which goes from tyre force to tyre side slip angle. The conversion is based on a description of the tyre force as the third degree of a polynomial where the coefficients are functions of Magic formula coefficients (25). Using a known inverse of the polynomial, the tyre side slip angle is presented as a function of lateral force. The steering angle can then be directly governed by adjusting for vehicle slip at the wheel in question. Another inverse model of a tyre is presented in (22), where the Magic formula is shortened and inverted for a particular range of side slip angles. The torques needed from the in-wheel motors are derived from the longitudinal tyre forces.

8.3 Path controller

The authors in (19-21) implement path control with the aim of minimising tracking error and securing vehicle stability when driving, by using the global forces and torque $\{F_x, F_y, M_z\}$ as control variables. The control commands that result, are the necessary wheel steering angles, in-wheel motor torque and actuation from friction brakes, if and when needed. The vehicle model is composed of a transfer function referred to as S in Figure 4, which derives global forces and torque from actual steering and torque. This is followed by a dynamic vehicle model which is an extended bicycle equation in order to derive the path (Figure 4). This dynamic vehicle model is not linear and one method of solving this is to accomplish feedback linearisation, as in (20-22), where the non-linearities are cancelled and the equations become decoupled in order to be able to use standard control methods.

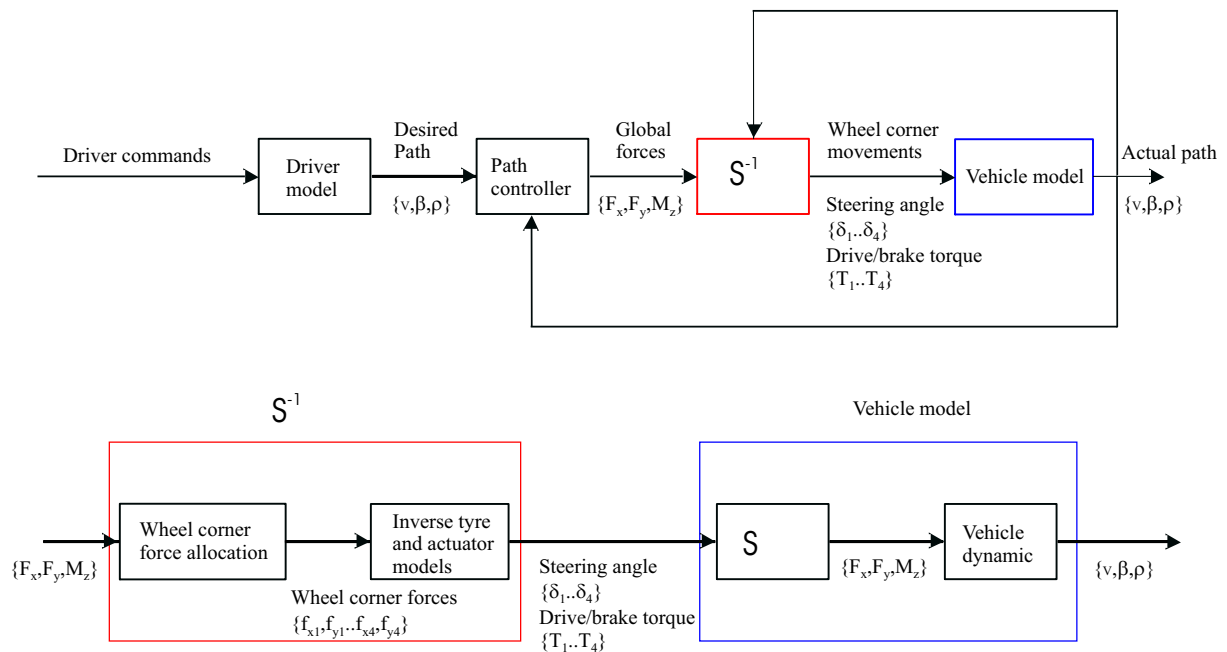

Figure 4. Models showing control of the vehicle following a desired path (20-22).

Naturally, the corner force limitation restricts the path. In order to control the path properly and to optimise corner force allocation, global force and torque limitations have to be known,

even during the most advanced manoeuvre. One method is firstly to state the tyre and actuator limitations, and then work backwards to global force limitations, torque limitations and vehicle path limitations by the use of inverse transformations.

Different control laws for the path are further investigated (20) where a PI controller has been used and in (22) where one presumes the driver controls the track, thus allowing for proportional feedback without integral action.

9 VEHICLE HIERARCHY

The ACM belongs to the class of a distributed real-time system where each ACM is working in real-time and interact with each other to support a common task. They work as individual nodes via a real-time communication network and need to be continuously regulated. One reason for this is the absence of dynamic equilibrium, caused by the replacement of mechanical to by-wire technology. Some functions may be handled internally for each ACM in real-time without interacting with the other ACMs, but the spontaneous method is to organise the ACMs under a common controller.

Keeping in mind the very long incremental development of the conventional chassis, dependability is and will be a difficult issue to deal with. Dependability is the ability of the ACM to deliver an expected behaviour that the user can trust. This behaviour is defined in a specification on which the user has agreed. A further example of associated concepts for distributed real-time systems where dependability is of great interest is brake-by-wire. The author in (25) presents methods for validating brake-by-wire systems in the early stages of the development process in order to prevent hazardous events, and concludes that computer simulations must take into account injection failures as well as the various hazard and risk analyses.

A three-level hierarchy is described (4), where level three is a longitudinal speed-dependent controller with the driver commands representing input and steering wheel angles representing output. This controller is followed by a stability and coordination system, placed in level two to control each ACM in level one. However, one major weakness using this hierarchy will be steering which is calculated before stability control. Wheel angle calculations must be performed as an interaction of driver commands and strategy of stability control.

A vehicle chassis with ACM could be offered with several configurations for energy buffers and energy transformers providing the ACM with enough power and energy for actuation. The vehicle could also be provided with various ACMs to meet different customer and market demands. The variety of configurations requires a hierarchy for controlling the vehicle. The hierarchy must be prepared for replacement of sub-systems and components and should enable the vehicle manufacture to set the brand-specific attributes.

In (27) a hierarchy is proposed to meet the needs mentioned. That hierarchy is composed of a Driver Interpreter, at the highest functional level, to process the driver commands to Energy Management (EM) and Vehicle Motion Control (VMC). The EM calculates the power needs for propulsion and auxiliary systems and, if the vehicle is provided with batteries, the EM controls the state of charge. A Strategic Control (SC) makes decisions and necessary priorities from the EM and VMC requests. Moreover, the SC directly informs each wheel unit about the

required force allocations. The wheel unit should also inform the SC about the maximum forces that could be generated in order to control the vehicle as described in Section 8.

10 CONCLUSION

This work has clearly demonstrated that a number of systems and methods for active chassis control can be used to improve vehicle dynamics, fulfilling one or a few desired properties. These systems, which are rather costly and technically complex, are being refined to do a specific task perfectly, but do not offer the flexibility to influence functions of a wider perspective. In turn, if more functions are needed then additional chassis systems need to be added.

The ACM benefits from many degrees of freedom as concerns kinematics where tyre forces can more easily be controlled and more closely distributed to the contact patch. This benefit makes it possible to extensively implement a great number of the functions covered in associated work. Thus, this work shows that the ACM introduces new opportunities and shows itself to be a promising enabler for vehicle dynamic functions. Of course, the ACM has a high unsprung mass and an undeveloped level of dependability. These are problems that need to be resolved if this technology is to be fully exploited. This work naturally proposes additional research on how the ACM should be designed including actuator composition and control algorithms to achieve the best driving dynamics.

ACKNOWLEDGEMENTS

This work was financed in part by the Swedish National Energy Agency.

REFERENCES

- (1) S. Zetterström, "Electromechanical steering, suspension, drive and brake modules", Proceedings of IEEE 56th Vehicular Technology Conference, vol. 56, no. 3, pp. 1856-1863, September 24-28, 2002.
- (2) S. Zetterström, "Vehicle wheel suspension arrangement", patent no. EP1144212, 1998.
- (3) K. Eklund, R Ortsater, J. Larsson, and H. Sundberg, "Konstruktion av autonomt hjulhorn", Master thesis no. LiTH IKP R 1302 (in Swedish), 2003.
- (4) J. A. A. Zachrisson, M. Rosth and R. Werndin, "Evolve – a vehicle based test platform for active rear axle camber and steering control", 2003 SAE World Congress, Detroit, SAE 2003-01-0581, March 3-6, 2003.
- (5) X. Eloy, "Analysis of the causes of irregular wear of tyres, investigation methods", Autotechnologies Conference and Exposition, Monte Carlo, Monaco, 1989.
- (6) "Tyre facts", Available: <http://www.bridgwatertyresandexhausts.com>.
- (7) "Carving car", Available: <http://car.kak.net/>.
- (8) S. I. Sakai, H. Sado, Y. Hori, "Dynamic driving/braking force distribution in electric vehicles with independently driven four wheels", Electrical Engineering in Japan, vol. 138, no. 1, 2002.
- (9) P. Wälterman, "Modelling and control of the longitudinal and lateral dynamics of a series hybrid", Proceedings of the 1996 IEEE International Conference on Control Applications, September 15-18, 1996.
- (10) S. I. Sakai, H. Sado and Y. Hori, "Motion control in an electric vehicle with four independently driven in-wheel motors", IEEE/AMSE Transaction on Mechatronics, vol. 4, no. 1, March, 1999.

- (11) B. Jacobson, "Potential of electric wheel motors as new chassis actuators for vehicle maneuvering", Proceedings of the Institution of Mechanical Engineers, vol. 216, no. D8, pp. 631-640, 2002.
- (12) S. Brodd and A. Söderström, "4WS advantages with respect to side wind stability", ImechE, C466/034, 1993.
- (13) S. Sano, Y. Furukawa, S Shiraishi, "Modification of vehicle handling performance by four-wheel steering system", 10th International Technical Conference on Experimental Safety Vehicles, Oxford, UK, July 1-5, 1985.
- (14) A. G. Nalecz and A. C. Bindemann, "Handling properties of four wheel steering vehicles", SAE paper 890080, pp. 63-68, 1989.
- (15) T. Naval, "Controller of magneto-rheological semi-active suspension for hybrid electric vehicle", Proceedings of the 21st Electric Vehicle Symposium, April, 2005.
- (16) F. D. Goncalves and M. Ahmadian, "Experimental investigation of the energy dissipated in a magnetorheological damper for semi-active vehicle suspension", ASME 2003 International Mechanical Engineering Congress and RD&D Expo, Washington, D.C., USA, November 15-21, AMSE 2003.
- (17) M. Montazeri-GH and M. Kashani Azad, "Energy regeneration of active suspension system in hybrid electric vehicle", International Symposium on Advanced Vehicle Control 2002, September 9-13, Hiroshima, Japan, 2002.
- (18) Illustration by Sven-Olof Persson, Designer at Volvo Car Corporation, April 2006.
- (19) S. Beiker and M. Mitschke, "Verbesserungsmöglichkeiten des fahrverhaltens von pkw durch zusammenwirkende regelsysteme", ATZ, 1/2001 (in German), 2001.
- (20) J. Fredriksson, J. Andreasson and L. Laine, "Wheel force distribution for improved handling in a hybrid electric vehicle using nonlinear control", Proceedings of the 43rd IEEE Conference on Decision and Control, vol. 4, pp. 4081-4086, 2004.
- (21) J. Andreasson and L. Laine, "Evaluation of a generic vehicle motion control architecture", FISITA 2004 World Automotive Congress, Spain, 2004.
- (22) R. Orend, "Modelling and control of a vehicle with single chassis actuators", IFAC Word Congress 2005, Prague, Czechoslovakia, 2005.
- (23) J. Andreasson and L. Laine, "Driving dynamics for hybrid electric vehicles considering handling and control architecture", Supplement to Vehicle System Dynamics, vol. 41, pp. 497-506, 2003.
- (24) C. Knobel, A. Pruckner and T. Bunte, "Optimized force allocation – a general approach to control and to investigate the motion of over-actuated vehicles", in accepted paper for 4th IFAC Symposium on Mechatronics, Germany, 2006.
- (25) H. B. Pacejca, "Tyre and vehicle dynamics", ISBN 0 7506 5141 5, Butterworth Heinmann, Oxford, United Kingdom, 2002.
- (26) J. Ehret, "Validation of safety-critical distributed real-time systems", Dissertation, Technischen Universität München, Germany, 2003.
- (27) L. Laine and J. Andreasson, "Generic control architecture applied to a hybrid electric sports utility vehicle", Proceedings of the 20th Electric Vehicle Symposium, EVS20, Long Beach, CA, November 15-19, 2003.