

7th International Building Physics Conference

IBPC2018

Proceedings

SYRACUSE, NY, USA

September 23 - 26, 2018

Healthy, Intelligent and Resilient
Buildings and Urban Environments

ibpc2018.org | [#ibpc2018](https://twitter.com/ibpc2018)



Generating design-sensitive occupant-related schedules for building performance simulations

Mohamed Ouf^{1,*}, William O'Brien¹ and Burak Gunay¹

¹Carleton University, Ottawa, ON, Canada

*Corresponding email: mohamedouf@cunet.carleton.ca

ABSTRACT

Despite the benefits of occupant behavior (OB) models in simulating the effect of design factors on OB, there are challenges associated with their use in the building simulation industry due to extensive time and computational requirements. To this end, we present a novel method to incorporate these models in building performance simulations (BPS) as design-sensitive schedules. Over 2,900 design alternatives of an office were generated by varying orientation, window to wall ratio (WWR), the optical characteristics of windows and blinds, as well as indoor surfaces' reflectance. By using daylight simulations and stochastic OB modeling, unique light use schedules were generated for each design alternative. A decision tree was then developed to be used by building designers to select light use schedules based on design parameters. These findings are relevant for building energy codes as they provide an approach to incorporate design-sensitive operational schedules for use as BPS inputs by practitioners. These design-sensitive schedules are expected to be superior to default ones currently specified in codes and standards, which ignore the effect of design factors on OB, and ultimately on energy consumption.

KEYWORDS

occupant behavior modeling; light use schedules; building performance simulation; decision trees; office buildings

INTRODUCTION

Occupant behavior (OB) is recognized as one of the sources of uncertainty in building performance simulations (BPS) (Delzende et al., 2017; Haldi and Robinson, 2010; Parys et al., 2011). It is often represented in BPS based on default assumptions rather than measured observations or predictive models (Virote and Neves-Silva, 2012), which could lead to a performance gap between estimated and measured energy consumption (Menezes et al., 2012). Default schedules, specified in building energy codes and standards, do not necessarily reflect the way buildings are occupied and used today, given new societal and technological trends (O'Brien et al., 2017). For example, default schedules assume 90 – 95% occupancy for office buildings during regular business hours. However, previous studies showed that peak occupancy rarely exceeds 50% in private offices (Duarte et al., 2015). The current schedule-based occupant modeling approach also assumes occupants are passive recipients of indoor environmental conditions and do not react to discomfort (Hong et al., 2015). However, the relationship between occupants and buildings is a two-way process, in which occupants' actions that influence energy consumption, are in turn influenced by building design and indoor environmental conditions (Gaetani et al., 2016; Haldi and Robinson, 2010; Yan et al., 2015). Therefore, default schedules that are currently prescribed in building energy codes and standards do not incentivize designers to explore the effect of design decisions on OB.

To partially address this issue, previous studies introduced stochastic models to represent OB more accurately in BPS based on monitoring of existing buildings (e.g. Haldi and Robinson,

2010; Page et al., 2008; Reinhart, 2004). These models can simulate occupants' presence or actions when triggered by environmental or situational conditions (Hong et al., 2016; Parys et al., 2011). Actions may include the use of lights, blinds, windows, thermostats or other building systems. Despite the advances in OB modeling research in the past decade, several issues remain unresolved such as these models' transferability and validation on a wider scale (Lindner et al., 2017). Similarly, the significant computation time required to run these models in BPS hinders their use in the building simulation industry, which is the main issue we address in this paper.

Quantifying the effect of OB on buildings' energy consumption requires integrating OB models in BPS tools. Several approaches can be used to achieve this, depending on the specific tool being used, its capabilities, and the available information about the model (Hong et al., 2017). Regardless of which approach to follow, one of the main challenges facing OB models' implementation in the building simulation industry is the extensive time and computational requirements for integrating them in BPS tools (Yan et al., 2015). As an alternative approach, we present a workflow to generate design-sensitive schedules that can be readily used as BPS inputs. Generating these design-sensitive schedules is based on parametric simulations of building design alternatives and using data-mining techniques to establish the relationship between design parameters and operational schedules. The process of generating these schedules which entails modeling OB needs to be performed only once, while its results can be used by building simulation practitioners to select design-sensitive schedules for their proposed designs.

The main goal of this paper is to provide a proof of concept application of the proposed workflow. However, undertaking this workflow on a larger scale to include other design factors, end-uses, and locations is a necessary step before results can be used by building simulation practitioners. Specific objectives of this study focused on generating light use schedules for 2,916 unique design alternatives of an office in Ottawa, ON. For each design alternative, parameters that influence workplane illuminance, and consequently the way occupants use lights were changed. These design parameters included, building orientation, WWR, windows and blinds' visible transmittance, wall, floor, and ceiling materials' reflectance. The second objective focused on developing a decision tree classification model to help in selecting light use schedules based on design parameters.

METHOD

The RADIANCE-based simulation program DAYSIM was used to calculate workplane illuminance in an office room during the whole year. The shoe-box office model, shown in Figure 1, had a floor area of 15 m² and height of 3 m², and was simulated in Ottawa, ON.

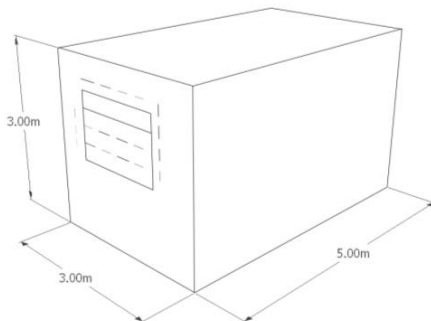

Figure 1 Three-dimensional diagram of the modeled shoe-box office

All possible combinations of the design parameters shown in Table 1 were modeled, resulting in 2,916 design alternatives. A window was modeled on one façade, whose dimensions were calculated to correspond to the proposed WWR for each design alternative. Since workplane illuminance, which triggers the use of lights is also influenced by blinds' position, five whole-year simulations were performed with the blind position in five equal increments: fully open, 1/4, 1/2, 3/4, and fully closed, resulting in a total of 14,580 simulations.

Table 1 Design parameters used to model different design alternatives of the shoe-box office model

Design parameters	Variations			
	South - 0°	West - 90°	North - 180°	East - 270°
Building Orientation	South - 0°	West - 90°	North - 180°	East - 270°
WWR	20%	40%	60%	
Glazing Visible Transmittance	0.5	0.6	0.7	
Blinds Visible Transmittance	0.05	0.1	0.15	
Ceiling Reflectance	0.6	0.7	0.8	
Floor Reflectance	0.2	0.3	0.4	
Wall Reflectance	0.4	0.5	0.6	

The next step entailed generating light use schedules for each design alternative based on modeling OB. An occupancy model developed by Page et al. (2008), a blind use model developed by Haldi and Robinson (2010), and a light use model developed by Reinhart (2004) were implemented in MATLAB for each design alternative. Details about these models' parameters and their implementation process can be found in Gunay et al. (2016), and Lindner et al. (2017). Results were used to calculate an average daily light use schedule for each design alternative, based on their annual light use profile.

A decision tree classification model, developed using the Classification and Regression Trees (CART) algorithm by Breiman et al. (1984), was then implemented in MATLAB to predict daily light use based on design parameters. This algorithm generates a flowchart tree structure to categorize data into various subsets and is applicable for predicting categorical responses. Therefore, the average daily light use schedules which represent the target response were first transformed into a categorical variable. For each design alternative, the duration of light use per day was calculated from its daily light use schedule generated earlier. The duration of light use was then categorized as High, Medium, or Low by splitting the dataset equally over these three categories. Results of this equal split indicated that light use durations below 5.7 hours/day were classified as low, durations between 5.7 and 6.7 hours/day were classified as medium, and durations above 6.7 hours/day were classified as high. Therefore, three categories of light use schedules were used to build the decision tree classification model, by assigning each of the 2,916 design alternatives to one of these categories.

To provide a practical application for the developed decision tree classification model, three distinct light use schedules were specified that correspond to the three categories of light use durations. These schedules can be used as inputs in BPS tools, and have the same shape profile as the average light use schedule calculated from the entire dataset for all design alternatives. They were generated by normalizing the average light use schedule for all design alternatives, and multiplying it by the average light use duration of each category (5.15, 6.2, 7.4 hours/day for low, medium and high categories, respectively).

Developing the decision tree was a two-step process, where the dataset was split into two subsets; a training subset randomly populated using 80% of the data, and a validation subset populated using the remaining 20%. Readers can refer to (Breiman et al., 1984) for more

details on the methodology of developing decision tree classification models. The training subset was then used to generate the model, while its accuracy was evaluated by making predictions against the validation subset. Accuracy was measured by comparing the predicted categorical response from the model to the original category of each data-point in the validation subset. Furthermore, the relationship between original values of light use duration in the validation subset (prior to categorization), and the average light use duration of its predicted category was assessed using the coefficient of determination R^2 .

RESULTS

Using the CART algorithm, a classification decision tree, shown in Figure 2, was developed. Post-pruning the decision tree with a confidence factor of 0.01 resulted in a total of seven decision tree nodes, of which eight were leaf nodes, representing low, medium, or high light use durations. The confusion matrix, shown in Table 2, evaluated the decision tree's classification accuracy. It indicated that 61% of the validation dataset, were correctly classified. However, only 1.9% of the dataset was incorrectly classified by more than one profile away from the correct one (e.g. High light use duration being classified as low). As shown in Table 2, the number of correctly classified records is given in the main diagonal, i.e. upper-left to lower-right diagonal; while others were incorrectly classified. Using the 584 records in the validation subset, and comparing their daily light use durations to the average light use duration of their predicted classes, R^2 was 0.66.

Despite the relatively low accuracy of this decision tree, one of its main advantages is the ease of use for practical applications by following the path from the root node to any of the leaf nodes. For example, if WWR is less than 0.3, building orientation is higher than 225° , and glazing visible transmittance is higher than 0.5, then medium light use duration and its corresponding schedule should be used in BPS. Changes to the parameters of the decision tree algorithm, the cross-validation method or the classification method used to split target variables can improve its accuracy. However, the main goal of this paper is demonstrating the workflow to generate design-sensitive schedules, and not improving the accuracy of the specific data-mining techniques used.

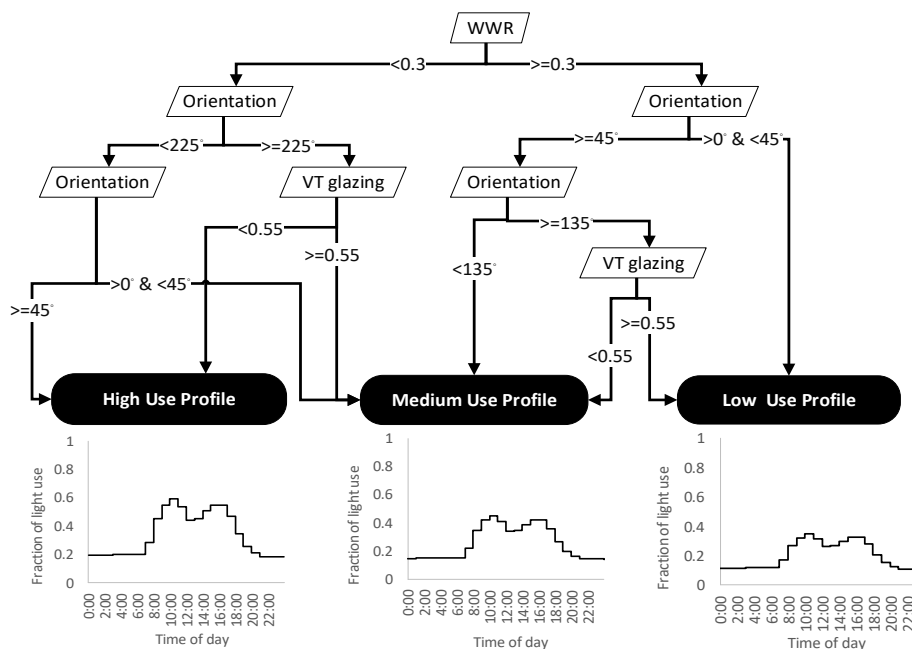

Figure 2 Decision tree diagram for selecting light use profiles

Table 2 Decision tree confusion matrix

Classified as →	Low light use profile	Medium light use profile	High light use profile
Low light use profile	137	49	4
Medium light use profile	78	116	50
High light use profile	7	39	103

DISCUSSION

Decision trees can help designers and building simulation practitioners select approximate light use schedules based on their design. Instead of using one default light use schedule that does not consider the effect of design parameters on OB, the proposed method provides three potential schedules that correspond to different building designs. Given the modeled office location in Ottawa, ON, future research should include other locations which can be treated as an additional parameter in the decision tree to select location-specific light use schedules.

It is important to note that the specific daily light use durations and schedules reported in this study were a function of the OB models used, and the design parameters investigated. However, more robust OB models and other parameters that influence OB such as clothing, and the decision to sit or stand at modern workstations should be investigated in future research. The presented workflow only focused on showing a methodology to eliminate the extensive time requirements for running OB models by providing design-sensitive schedules, but it did not address these models' transferability or validation in other buildings.

CONCLUSION

This paper demonstrated a novel method for generating design-sensitive schedules that can be used in BPS. For proof of concept, a decision tree was developed for selecting light use schedules based on design parameters. These design-sensitive schedules represent an improvement over the default schedules provided in current codes and standards, which do not match actual building operations. One approach to improve the accuracy of default schedules could be updating them based on data from a statistically representative sample of existing buildings, taking their design parameters into consideration. However, given the extensive logistical requirements for data collection at such large scale, the method presented in this paper relies on data-mining and parametric building simulations to account for the effect of building design on OB. This method only addresses the time and computational barriers to OB modeling, by providing ready-to-use design-sensitive schedules that can be used as BPS inputs. It does not address other issues related to OB modeling such as models' validation, which was outside the scope of this paper. Incorporating these schedules in building codes and standards would require extending the workflow on a larger scale for different locations and building archetypes.

ACKNOWLEDGEMENT

The generous financial support of Natural Resources Canada through the Clean Energy Innovation Program is acknowledged. The authors have greatly benefited from discussion with project partners RWDI, Autodesk, and National Research Council Canada, and would like to acknowledge their generous support for this research.

REFERENCES

- Breiman, L., Friedman, J., Stone, C.J., Olshen, R.A., 1984. Classification and Regression Trees. Chapman and Hall/CRC.
- Delzendeh, E., Wu, S., Lee, A., Zhou, Y., 2017. The impact of occupants' behaviours on

- building energy analysis: A research review. *Renew. Sustain. Energy Rev.* 80, 1061–1071. doi:10.1016/j.rser.2017.05.264
- Duarte, C., Budwig, R., Van Den Wymelenberg, K., 2015. Energy and demand implication of using recommended practice occupancy diversity factors compared to real occupancy data in whole building energy simulation. *J. Build. Perform. Simul.* 8, 408–423. doi:10.1080/19401493.2014.966275
- Gaetani, I., Hoes, P.J., Hensen, J.L.M., 2016. Occupant behavior in building energy simulation: Towards a fit-for-purpose modeling strategy. *Energy Build.* 121, 188–204. doi:10.1016/j.enbuild.2016.03.038
- Gunay, H.B., O'Brien, W., Beausoleil-Morrison, I., 2016. Implementation and comparison of existing occupant behaviour models in EnergyPlus. *J. Build. Perform. Simul.* 9, 567–588. doi:10.1080/19401493.2015.1102969
- Haldi, F., Robinson, D., 2010. Adaptive actions on shading devices in response to local visual stimuli. *J. Build. Perform. Simul.* 3, 135–153. doi:10.1080/19401490903580759
- Hong, T., Chen, Y., Belafi, Z., D'Oca, S., 2017. Occupant behavior models: Implementation and representation in building performance simulation programs. *Build. Simul.* doi:10.1007/s12273-017-0396-6
- Hong, T., D'Oca, S., Taylor-Lange, S.C., Turner, W.J.N., Chen, Y., Corgnati, S.P., 2015. An ontology to represent energy-related occupant behavior in buildings. Part I: Introduction to the DNAs framework. *Build. Environ.* 94, 196–205. doi:10.1016/j.buildenv.2015.08.006
- Hong, T., Taylor-Lange, S.C., D'Oca, S., Yan, D., Corgnati, S.P., 2016. Advances in research and applications of energy-related occupant behavior in buildings. *Energy Build.* 116, 694–702. doi:10.1016/j.enbuild.2015.11.052
- Lindner, A.J.M., Park, S., Mitterhofer, M., 2017. Determination of requirements on occupant behavior models for the use in building performance simulations. *Build. Simul.* 1–14. doi:10.1007/s12273-017-0394-8
- Menezes, A.C., Cripps, A., Bouchlaghem, D., Buswell, R., 2012. Predicted vs. actual energy performance of non-domestic buildings: Using post-occupancy evaluation data to reduce the performance gap. *Appl. Energy* 97, 355–364. doi:10.1016/j.apenergy.2011.11.075
- O'Brien, Gaetani, I., Gilani, S., Carlucci, S., Hoes, P.-J., Hensen, J.L.M., 2017. International survey on current occupant modelling approaches in building performance simulation? *J. Build. Perform. Simul.* doi:10.1080/19401493.2016.1243731
- Page, J., Robinson, D., Morel, N., Scartezzini, J., 2008. A generalised stochastic model for the simulation of occupant presence 40, 83–98. doi:10.1016/j.enbuild.2007.01.018
- Parys, W., Saelens, D., Hens, H., 2011. Coupling of dynamic building simulation with stochastic modelling of occupant behaviour in offices - a review-based integrated methodology. *J. Build. Perform. Simul.* 4, 339–358. doi:10.1080/19401493.2010.524711
- Reinhart, C.F., 2004. Lightswitch-2002: A model for manual and automated control of electric lighting and blinds. *Sol. Energy* 77, 15–28. doi:10.1016/j.solener.2004.04.003
- Virote, J., Neves-Silva, R., 2012. Stochastic models for building energy prediction based on occupant behavior assessment. *Energy Build.* 53, 183–193. doi:10.1016/j.enbuild.2012.06.001
- Wang, D., Federspiel, C.C., Rubinstein, F., 2005. Modeling occupancy in single person offices 37, 121–126. doi:10.1016/j.enbuild.2004.06.015
- Yan, D., O'Brien, W., Hong, T., Feng, X., Burak Gunay, H., Tahmasebi, F., Mahdavi, A., 2015. Occupant behavior modeling for building performance simulation: Current state and future challenges. *Energy Build.* 107, 264–278. doi:10.1016/j.enbuild.2015.08.032