

70<sup>th</sup> International Astronautical Congress (IAC), Washington D.C., United States, 21-25 October 2019.  
Copyright ©2019 by the International Astronautical Federation (IAF). All rights reserved.

IAC-19.B4.3.9x50773

## L.A.R.S. - Mobile ground station for CubeSat operations

Sebastian Fexer\*, Lars-Christian Hauer

*Institute of Space Systems, German Aerospace Center (DLR), Robert-Hooke-Str. 7, 28359 Bremen, Germany,*

E-Mail: [sebastian.fexer@dlr.de](mailto:sebastian.fexer@dlr.de); [lars-christian.hauer@dlr.de](mailto:lars-christian.hauer@dlr.de)

\* Corresponding Author

### Abstract

Many of the CubeSat and SmallSat operators in the academic field suffer from the fact that the ground station operations for Telemetry, Tracking and Control of their satellites is often quite challenging to maintain for the duration of a mission.

The DLR Institute of Space Systems in Bremen, Germany, presents a remote controllable mobile ground station for CubeSat/SmallSat operations which completely fits inside a 20 ft shipping container. It operates in the VHF/UHF amateur radio frequency bands (144-146 MHz and 430-440 MHz) and is prepared for S band (2400-2450 MHz) using fully redundant state-of-the-art software-defined-radio transceivers. With the ground station presented in this paper, automated satellite operations with different satellites can be achieved.

Tests with different SmallSats and CubeSats have demonstrated promising results of great performance with high sensitivity in reception, even at low elevations. Currently, the ground station is located for testing purposes at the Jade Weser Airport in Wilhelmshaven, Germany. In the near future it is planned to move the station to a northern location to achieve optimal contact opportunities to connect and remain in contact for longer durations in polar satellite orbits.

**Keywords:** (maximum 6 keywords) CubeSat; SmallSat; ground station

### Acronyms/Abbreviations

Automatic Dependent Surveillance - Broadcast (ADS-B)	Ultra High Frequency (UHF)
Automatic Identification System (AIS)	Uninterruptable Power Supply (UPS)
Direct Down Conversion (DDC)	Universal Time, Coordinated (UTC)
Inter frequency (IF)	Very High Frequency (VHF)
Low earth orbit (LEO)	Weak Signal Propagation Reporter (WSPR)
Low-frequency Arctic Radio Station (L.A.R.S.)	
Power amplifier (PA)	
Power Supply Unit (PSU)	
Radio Frequency (RF)	
Receiver (RX)	
Software defined radio (SDR)	
Telemetry, Tracking & Control (TT&C)	
Transceiver (TRX)	
Two-line element (TLE)	

## 1. Introduction and background

The mobile ground station L.A.R.S. (Low-frequency Arctic Radio Station) has been initially designed to assist in TT&C of the AISat Mission of the DLR Institute of Space Systems in Bremen [1]. The ground station is able to operate in the VHF and UHF amateur radio bands and is prepared for S Band.

Besides the rooftop mounted VHF/UHF ground station at the Institute of Space Systems, there was the wish for an additional automated ground station. Moreover, in the exchange with other CubeSat operators such as universities, it seemed often to be a challenge to maintain operations for the duration of a mission. Especially if an (academic) organisation or university is developing and launching its first CubeSat, knowledge and experience in radio equipment and ground station antennas has to be gained, e.g. by the help of a local radio amateur group. Also the availability of the necessary facilities to implement a ground station (with an exposed and quiet place for antennas, space for cable routing, with radio room) has to be first established. Further challenges can evolve due to staff related issues like student fluctuation or unusual working times.

Additionally, the site locations are mostly fixed and close to the satellite operators' premises (e.g. a university). This might not be always the optimum site for the used satellite orbit (e.g. close to the equator for ISS deployed CubeSats or near the polar regions for such orbits).

Below, a closer look is taken at the available passes of the Danish polar orbiting 1U CubeSat AAUSAT4 [2] at different locations.

Table 1 shows as an example ideal passes on September 16<sup>th</sup>, 2019 with the maximum elevation for a ground station located in Bremen, Germany. Only passes with an elevation of  $\alpha \geq 15$  deg. are shown.

In contrast, Table 2 depicts the available passes of this satellite at the same day in Thule, Greenland.

It can be seen that three times more passes are available which leads to significantly higher available downlink amount per day. Especially, if the remotely located ground station is used in addition to the fixed one.

Table 1. Available passes of AAUSAT4 on 16.09.19 at the Bremen ground station with the maximum elevation

UTC	$\alpha$ /deg.
11:33	48.2
13:07	19.1
22:23	77

Table 2. Available passes of AAUSAT4 on 16.09.19 in Thule, Greenland with the maximum elevation

UTC	$\alpha$ /deg.
0:13	50.7
1:47	89.1
3:22	38.8
4:58	17.5
16:13	22.4
17:49	49.4
19:23	78.4
20:58	47.2
22:32	40.3

## 2. Description of the L.A.R.S. system

In the subsequent paragraphs, the different parts of the system will be described in more detail. The focus will especially be placed on details regarding a robust concept, which can withstand harsh environment and operate with reduced available service, since maintenance personnel frequently visiting the facility will not be always available at a remote arctic location. E.g. a suitable antenna concept without moving parts had to be chosen to minimize maintenance effort.

### 2.1 The container – facility and utilities

A standard 20 ft long shipping container is used to house the ground station (as shown in Fig. 1). Its interior is split into two areas: a storage and working room, and the utilities room containing the servers and RF hardware (displayed in Fig. 2). The latter ones are each mounted inside a vibration-damped rack assembly.



Fig 1. Exterior view of the L.A.R.S. ground station



Fig 2. View from the working area into the utility room

The electric power system of the container guarantees a 230 V/50 Hz line voltage. All critical components are connected to a fully-redundant UPS system. A 10 kW transformer (115 V/230 V) at the electric main line can be joint up in circuit, if the container is placed in a country with a predominant line voltage of 115 V.

To ensure moderate room temperatures inside, a climate concept has been implemented to include insulation, two-zone-ventilation and a convection heating. The temperatures in the critical areas are continuously monitored, logged and the data can be accessed via web interface. Furthermore, the electric current drawn by the heater unit is logged to have the opportunity to detect anomalies.

The roof of the container is equipped with an antenna mounting and support rack to hold the four main antennas as well as secondary antennas like short-wave wires in place. It also offers space for future extensions. For container transport and relocation it can be detached and stowed inside the container.

## 2.2 Computer hardware and remote control

The ground station is equipped with a fully redundant server system for data storage, controlling the RF hardware and the coding/decoding of the satellite signals. Housekeeping such as temperature data- and heater status logging or CCTV camera control is realized with a Raspberry Pi based system.

The communication to the outside world is maintained by a permanent VPN tunnel to the institute's premises in Bremen, Germany.



Fig 3. Remote controlled user terminal with application software

To provide convenient access to all functions, a remote controlled user terminal has been designed. Utilizing three touch-sensitive screens, all functions and statuses can be accessed. The graphical user interface is inspired by industrial control panels and hence optimized for operation via touch screen. A more detailed insight into the software is given in section 1.5.

## 2.3 Antenna system for TT&C

A trade-off has shown that an “eggbeater” antenna [3] (displayed in Fig. 1, mounted on top of the masts) can be a good choice for satellites in LEO orbit in the given frequency bands of VHF and UHF. This type of antenna has a cardioid shaped radiation pattern (see Fig. 4). It features a low wind loading and furthermore has no moving parts (e.g. a rotator) which can be critical to use and maintain under arctic environment. Moreover, it offers circular polarization.

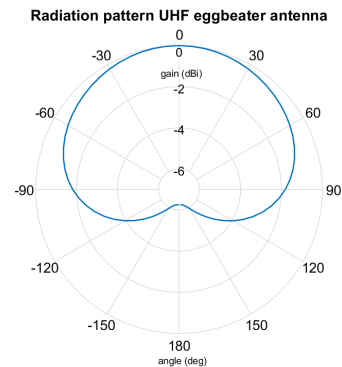

Fig 4. Cardioid shaped antenna radiation pattern of an eggbeater antenna (normalized)



Fig 5. UHF antenna attached to test boom during ice test. The ice layer has an approximately height of 13 cm (r.)

The eggbeater antenna consists of two loops, each one wavelength in circumference, shifted by 90 degree to each other. The required circular polarization is achieved by a phase difference (e.g. via phasing lines) between the feed of the two loops.

The added ground plane can be either made of metal wires or from a solid sheet and provides the desired unidirectional antenna pattern. The distance between the antenna and the ground plane is responsible for the shape of the radiation pattern and the maximum gain, which can be around approximately 4 to 6 dBi [4].

The eggbeater antennas used in this project have a peak gain of approximately 5.5 dBi.

For redundancy reasons, two antennas for each of the amateur frequency bands are used.

Extensive tests were conducted in low temperatures and the resulting side effects were studied, such as snow and ice affecting the antenna's performance. The antennas have been prepared with different layers of snow and ice of different height and extent and were subsequently measured using a network analyser. Fig. 5 shows an UHF antenna during a test with ice coverage of ~13 cm. The measurement results are illustrated in Fig. 6.

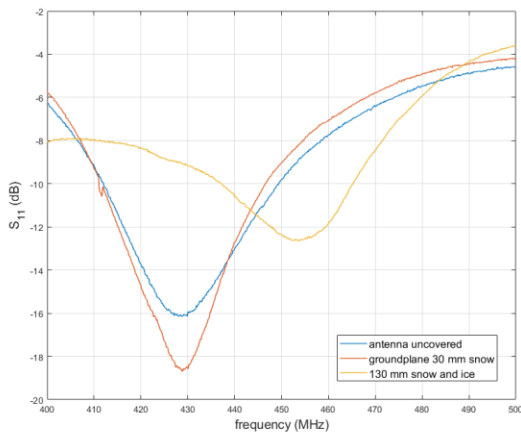

Fig 6. Measured input reflection coefficient  $S_{11}$  of UHF eggbeater antennas for different snow/ice conditions



Fig. 7. RF rack. From top to bottom: redundant transceivers, switching matrix, VHF/UHF/S Band frontends, PSU

The tests have shown that light to medium snow coverage has almost no influence on the performance of the input reflection coefficient/S-Parameter  $S_{11}$ . Under conditions with heavy icing, a right shift towards higher frequencies could be observed. A satisfying input reflection coefficient ( $S_{11} < -10$  dB) at the desired frequencies could not be achieved any longer. As a consequence, the antennas with a solid metal sheet ground plane have been replaced by a version with metal wires, which prevents excessive accumulation of snow and ice.

#### 2.4 The hardware of the RF system

The complete RF section of the container is installed in a dedicated 19 inch rack. In Fig. 7 the part responsible for the satellite section is shown.

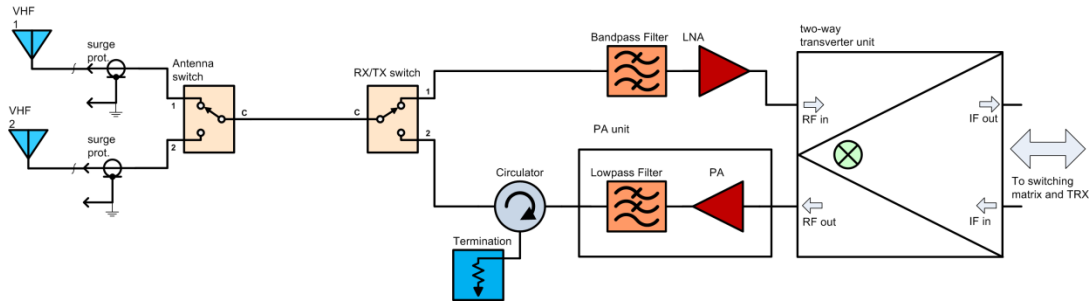

Fig 8. Simplified block structure of the VHF segment of the RF unit of the L.A.R.S. ground station

#### 2.4.1 RF frontend

The RF frontend is divided into three independent paths with almost identical block structure for each frequency band (VHF/UHF/S Band).

In Fig. 8, a (simplified) block structure of the VHF branch is shown. Each branch is connected to a switching matrix which is responsible for the correct distribution of the RX/TX IF signals to one of the two transceivers.

In the following, the signal path will be explained for the illustrated VHF branch as an example.

Looking at the receiving signal path as seen from the antenna side, a bank of surge protectors is installed to guard the following section from possible overvoltage. A switching unit allows to choose between the two redundant antennas, followed by a RF switch for RX/TX, a bandpass filter for preselection and a low-noise amplifier.

The subsequent two-way transverter block is responsible for the down conversion of the signal towards the IF, which is located in the short wave band. Finally, the switching matrix (not included in the figure) routes the signal to the RX input of one of the transceivers. These will be described further in section 2.4.2.

In transmitting mode, the IF signal, modulated by the transceiver and routed through the switching matrix, enters the VHF branch at the transverter input. There the signal is being upconverted and enters the power amplifier stage. To suppress harmonics, a low pass filter is integrated in the PA section. This is especially important, since the third harmonic falls into the UHF amateur band.

To avoid mismatching at the PA output which could for example occur in the case of an antenna failure and possibly lead to damage, an isolator is connected

downstream. Behind the RX/TX switch, the antenna selector, and the surge protectors, the antennas are connected.

The maximum PA output power of the VHF and UHF branch is 100 W each, S band offers 10 W.

#### 2.4.2 Transceiver system and IT interface

As the last stage in the RF chain, two redundant transceivers are connected to the switching matrix with their respective IF outputs. These commercial all-digital shortwave radios are based on the direct down conversion technology and inhibit some special modifications for their application in the ground station.

Instead of using hardware modems with limited flexibility and problematic interchangeability (due to remote operations), the approach of software modulation/demodulation was preferred.

The transmission of the baseband signals between the transceiver and the server system is realized via simple audio connection. In each server system, one high quality sound card is installed for this purpose.

This method emerged as a quasi-standard in the amateur radio community and a lot of free and open-source software is available for signal reception. For different protocols or uplink transmission for a mission, the appropriate software has to be provided by the satellite operator.

#### 2.5 Software and reception system

The whole system is managed by a proprietary software, consisting of a driver on the server side, and the user interface on the remote user terminal side. It acts as an interface between the user and the hardware, which is controlled by different bus systems. The transceivers are each controlled via USB, the RF hardware such as the switching matrices and amplifiers, as well as the diagnostic system via CAN bus.

The two redundant servers are acting as a “main” and “spare” device, both running the host drivers. In nominal operation, only the “main” server controls the ground station system. If the host drivers, which contain a watchdog functionality, detects some anomaly in form of unresponsivity of the “main” system, all functionality will be automatically handed over to the “spare” system.

In the user interface, six “quick access” buttons allow access to user-defined satellite scenarios. But all relevant parameters like frequency offset, bandwidth, modulation etc. can be also changed “on-the-fly”. The built-in Doppler correction provides the correct frequency for up- and downlink. The used method for the Doppler correction can be selected. For instance, via orbital parameters (TLE file) or maximum signal strength. With the use of a dedicated program, available passes can be visualized and scheduled.

### 2.5.1 Monitoring system

All critical voltages, currents, temperatures (e.g. for the PA) or the transmitter output- vs. reflected power are monitored and transmitted to the main system via CAN bus. From here, the data is distributed to the servers and finally provided to the operator.

## 2.6 Additional reception systems

In addition to the ground station’s main purpose of satellite operations, there was still space for other related RF systems, which are partially experimental. These are described briefly in the following paragraphs.

### 2.6.1 Automatic Identification System (AIS)

The AIS system is a worldwide system for maritime vessel tracking. Ships above a certain tonnage as well as all passenger ships are required to be equipped with an AIS transmitter. These transmitters broadcast the current position as well as additional information like speed, heading etc. on 162 MHz.

Since the DLR - Institute of Space Systems has a variety of activities in the AIS sector – including the AISat, which carried several receivers and antenna technology on board, AIS ground reference stations had to be available for comparison of the data. The L.A.R.S. ground station is equipped with a commercial AIS receiver, which data whose data is stored and makes it available in the network.

### 2.6.2 ADS-B aircraft monitoring

ADS-B is an aircraft surveillance system, where each aircraft broadcasts information like the current

position, start and destination or ground speed on 1090 MHz. ADS-B, also satellite based, has been a research topic at the Institute of Space Systems for a long time. Aboard the ESA satellite PROBA-V, an ADS-B receiver from DLR has been tested successfully [5].

Like for the AIS system, having access to ground reference data is desired to compare it with the recorded data from space.

A small redundant dual-receiver unit is used for this purpose. The received data can be directly streamed to the local network. For reception, a 1090 MHz ground plane antenna is mounted atop the container.

### 2.6.3 WSPR multiband receiver

The WSPR protocol, initiated by the US American radio amateur Joe Taylor (K1JT), is used to establish connections between radio stations and transmit the results to an internet database. A distinctive feature of the protocol is, that only a very low signal-to-noise ratio down to approximately -28 dB (on average) is required for proper reception.

WSPR is mainly used in low-power (QRP) transmissions, typically below 1 W, to draw conclusions about the atmospheric propagation of radio waves. Usually, WSPR is mostly being used on short wave frequencies, since their propagation behaviour is most prone to atmospheric conditions. The stations with the corresponding call signs and successful connections can be seen at a map of the project’s web site [6].

The L.A.R.S. container inhibits a multiband medium-/short wave WSPR receiver which can listen to eight bands from 160 m up to 10 m simultaneously. Received and decoded spots are uploaded to the project’s website. A similar decoder is installed on the German Antarctic research station Neumayer III (call sign DPOGVN). Currently, the receiver is also linked to the recently established WSPRlive database, which collects, analyses and illustrates the received data of all receivers participating in the network [7].

Antennas used for the WSPR receiver are two windom wire antennas in diversity configuration.

## 3. Results and discussion

Since the establishment of the L.A.R.S. ground station at the institute’s premises, a multitude of satellites were successfully received. Even satellites which do not have a (nearly) polar orbit, e.g. the Australian *UNSW-ECO* [8] which has been deployed from ISS, could be received with acceptable signal strength.

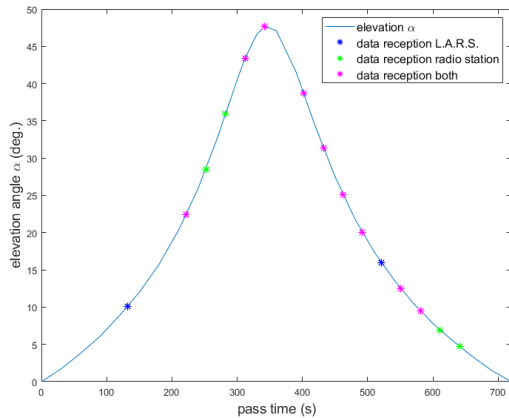

Fig 9. Comparison of received of AAUSAT4 data reception between ground stations, pass on 19.09.19 starting at 11:17 UTC

In Fig. 9, a pass of AAUSAT4 is shown, which has been received with the institute's fixed ground station as well as with the L.A.R.S. container. The fixed one uses a rotatable cross-yagi array antenna with a gain of 17 dBi and mast mounted pre-amplifier. As a decoding software, the freeware "Soundmodem 0.18b" in 2k4 baud mode has been used. Each properly decoded signal during the pass is marked with a dot in the graph, the color depicts the corresponding reception site. Despite the much weaker link budget of the L.A.R.S. container (due to the antenna design), still most of the messages could be decoded properly. Currently, some parameters in hard- and software are still analysed and optimized to achieve even better results and avoid mid-pass message losses.

In addition to the containers' main task as a satellite ground station, it has been continuously upgraded with additional RF equipment.

To achieve a better and more realistic testing environment, the ground station has been temporarily relocated from the Institute of Space Systems in Bremen to a remote location at the Jade Weser Airport near Wilhelmshaven, approximately 70 km northwest of Bremen. After the transfer of the ground station from the densely populated technology park of Bremen to the more rural area, a significant reduction of the noise floor could be achieved. Especially the reception of short wave signals for the WSPR receiver has been dramatically improved. Also the AIS and ADS-B receivers profit from the proximity to the sea, respective the airport. Due to its versatility, the ground station had been also assisted in tracking a high-altitude balloon during a mission, just by remotely reconfiguring the software.

As a next step, the relocation to a final site in the arctic regions is planned to serve polar orbiting satellites. Furthermore, upgrade options regarding a low-maintenance S Band antenna have to be evaluated.

## Acknowledgements

We thank all colleagues and partners being involved in the project, especially Alexander Smolko, Pascal Solmaz and Tom Thienel for the excellent technical assistance during the different phases of the project.

## References

- [1] B. Suhr et.al., AISat-1: Analysis Results, Deutscher Luft- und Raumfahrtkongress (DLRK) der DGLR, Rostock, Germany, 2015, 22 – 24 Sept.
- [2] AAUSAT4 Homepage of the University of Aalborg, Denmark, <http://www.space.aau.dk/aausat4>, (accessed 13.09.19).
- [3] Dick Janson, Antennas for Space Communication, in: H. Ward Silver, Steven R. Ford, Mark J. Wilson (Eds.), The ARRL Antenna Book for Radio Communications, ARRL, 22<sup>nd</sup> Edition, Newington, CT, USA, 2013, pp. 17-2/3; 17-8.
- [4] Alois Krischke, Rothammels Antennenbuch, 13<sup>th</sup> Edition, DARC Verlag, Baunatal, 2013.
- [5] T. Delovski, K. Werner et.al., ADS-B over Satellite The world's first ADS-B receiver in Space, Small Satellites Systems and Services Symposium, Mallorca, Spain, 2014, 26 – 30 May.
- [6] The Weak Signal Propagation Reporter Network, <http://wsprnet.org>, (accessed 16.09.19).
- [7] WSPRLive Website, <https://wsprlive.net>, (accessed 16.09.19).
- [8] J.W. Cheong et.al., Design and Development of the UNSW QB50 Cubesat - EC0, International Astronautical Congress, Guadalajara, Mexico, 2016, 26 – 30 Sept.