

70th International Astronautical Congress (IAC), Washington D.C., United States, 21-25 October 2019.
Copyright ©2019 by DLR. Published by the IAF, with permission and released to the IAF to publish in all forms.

IAC-19.D2.4.5x49370

Retro Propulsion Assisted Landing Technologies (RETALT): Current Status and Outlook of the EU Funded Project on Reusable Launch Vehicles

**Ansgar Marwege^{a*}, Ali Gülhan^{a*}, Josef Klevanski^a, Johannes Riehmer^a, Daniel Kirchheck^a, Sebastian Karl^a
Davide Bonetti^b, Jan Vos^c, Matthew Jevons^d, Anett Krammer^e, João Carvalho^f**

^a *DLR Institute of Aerodynamics and Flow Technology, Linder Höhe, 51147 Köln, Germany,
ansgar.marwege@dlr.de, ali.guelhan@dlr.de,*

^b *Flight Systems Business Unit DEIMOS Space S.L.U., Atmospheric Flight Competence Center, Ronda de Poniente,
19. Edificio Fiteni VI, portal 2, 28760 Tres Cantos (Madrid), Spain*

^c *CFS Engineering, EPFL Innovation Park, Batiment-A, 1015 Lausanne, Switzerland*

^d *MT Aerospace AG, Future Programs, Franz-Josef-Strauß-Straße 5, D-86153 Augsburg*

^e *Almatech Space & Naval Engineering, EPFL Innovation Park D, CH-1015 Lausanne*

^f *Amorim Cork Composite, Rua de Meladas 260, Mozelos VFR 4536 902, Portugal*

* Corresponding Author

Abstract

The development and operation of Reusable Launch Vehicles (RLV) are currently changing the global market of space transportation. A main game changer in this field are the technologies of retro propulsion assisted landing, which is a concept of decelerating the vehicle during its return to ground by firing its engines against the velocity vector.

To foster a cost-efficient and sustainable global and European launcher market there is not only an urgent need to build up the necessary know-how on state-of-the-art Vertical Take-off Vertical Landing (VTVL) Two Stage To Orbit (TSTO) concepts, but also to go beyond this approach. Historically, many concepts of Reusable Launch Vehicle (RLV) are based on Single Stage To Orbit (SSTO) designs. Therefore, in the EU Horizon 2020 project RETALT (RETro propulsion Assisted Landing Technologies), the VTVL approach is investigated in a twofold manner:

- A configuration similar to the SpaceX rocket “Falcon 9” serves as a reference for the state-of-the-art TSTO RLV.
- A configuration similar to the DC-X serves as a reference for a VTVL SSTO.

In this way, the concept of vertical landing with retro propulsion is investigated in a more general way and has the potential to be applied to more concepts of future RLV. In the RETALT project research for both reference configurations is performed in the areas of aerodynamics, aerothermodynamics and flight dynamics and GNC, as well as advanced structural parts, materials, health monitoring systems, TPS, mechanisms and advanced propulsion assisted landing systems.

This paper gives an overall overview of the project; the current status of the project will be presented and an outlook of future activities will be given. Furthermore, the configuration layout and landing concept of both configurations will be discussed in more detail. Advanced structures and mechanisms of RETALT configurations are discussed in a complementary paper (see ref. [1]).

Keywords: Retro-propulsion, Aerodynamics, Aerothermodynamics, Aerodynamic Database, Aerothermodynamic Database, Demonstrators

Acronyms/Abbreviations

RLV	Reusable Launch Vehicle
ELV	Expendable Launch Vehicle
SSTO	Single Stage to Orbit
TPS	Thermal Protection System
TSTO	Two Stage to Orbit
TVC	Thrust Vector Control
VTVL	Vertical Take-off Vertical Landing
RTLS	Return To Launch Site
DRL	Down Range Landing

AEDB	Aerodynamic Database
ATDB	Aerothermodynamic Database
GNC	Guidance Navigation and Control
MEIG	Main Engine Ignition
MECO	Main Engine Cut Off

1. Introduction

RETALT (RETro propulsion Assisted Landing Technologies) is a project which received a funding of 3 Mio. € from the EU Commission in the frame of the Horizon 2020 research and innovation programme

under grant agreement No 821890. The project started in March 2019 and will run for 3 years.

The partners of the project are: DLR (Germany), CFS Engineering (Switzerland), Elecnor Deimos (Spain), MT Aerospace (Germany), Almatech (Switzerland) and Amorim Cork Composites (Portugal).

For Europe's non-dependence, access to space has been recognized as an area of strategic importance. It is an indispensable element of the entire value chain of space. Access to space is a matter of security of supply, industry capability and technology readiness and a sine qua non condition of the modern space knowledge-based economies. [2]

The Space Strategy for Europe has confirmed that Europe shall maintain autonomous, reliable and cost-effective access to space. Cost reduction and improving flexibility of European launch systems are the main challenges in order to foster European industry competitiveness on the global market. [3]

One main game changer in the modern global market of launchers is their reusability. For a long time Reusable Launch Vehicles (RLV) were considered not to be more efficient than Expendable Launch Vehicles (ELV). New developments, mainly by the US-American companies SpaceX and Blue Origin, are changing this common opinion. For example, SpaceX is claiming considerable launch cost reductions by reusing flown first stages.

The key of the success of SpaceX is the concept of recovery of the first stage. The "Falcon 9" rocket is a Vertical Take-off Vertical Landing (VTVL) Two Stage To Orbit (TSTO) RLV. The deceleration of the first stage during return flight is performed with the main engines supported by aerodynamic control (grid fins and RCS). Firing an engine against the surrounding flow of the rocket is called retro propulsion. In Europe the research on this concept is just in its beginnings but is quickly picking up speed. In this context, the RETALT project focuses on retro propulsion assisted Vertical Take-off Vertical Landing, Two Stage to Orbit, Reusable Launch Vehicles.

To foster a cost-efficient and sustainable global and European launcher market, there is not only an urgent need for building up the necessary know-how on state-of-the-art VTVL TSTO concepts, but to go beyond this approach. Historically, many concepts of RLV are based on Single Stage To Orbit (SSTO) designs, e.g. the VentureStar, the DC-X and the Russian CORONA. In the RETALT project the VTVL approach is also investigated for SSTO RLV. In this way, the concept of vertical landing with retro propulsion is investigated in a more general way and has the potential to be applied to more concepts of future RLV.

This paper gives an overall overview of the project; the current status and main results of the project will be

presented and an outlook of future activities will be given.

2. Project Objectives

The objective of RETALT is to create a sound foundation of know-how for research and industry in the key technologies of retro propulsive landing. This aim can be divided into two main scientific and technological objectives:

- To investigate the launch system reusability technologies of VTVL TSTO RLV applying retro propulsion combined with aerodynamic control surfaces, which are currently dominating the global market. (short term future)
- To investigate the launch system reusability technologies of VTVL SSTO RLV applying retro propulsion for future space transportation systems. (technology test bed and long term future)

To meet these two scientific and technological objectives, two reference launch vehicle configurations are defined:

- **RETALT1:** A configuration similar to the SpaceX rocket "Falcon 9", which is the reference for the state-of-the-art TSTO RLV
- **RETALT2:** A configuration similar to the DC-X that serves as a reference for a VTVL SSTO.

A novel approach is applied which is reusing the interstage and the fairing as aerodynamic control surfaces. This has the potential to further reduce the costs of the launchers. From the main project objectives the following technical project objectives are derived:

- To improve the physical understanding of the complex turbulent unsteady aerodynamics and aerothermodynamics of RLV configurations with retro propulsion.
- To perform aerothermodynamic tests including retro hot plume in unique European facilities and CFD simulation of these experiments.
- To obtain reliable Aerodynamic Databases (AEDB) for Flying Qualities Analysis and Guidance Navigation and Control (GNC) of such configurations and for extrapolation to flight.
- To develop a Guidance Navigation and Control (GNC) Concept.
- To improve the understanding of the aerothermal performance of necessary structures, materials and mechanisms and the

creation of an Aerothermodynamic Database (ATDB)

- To develop new structural concepts and mechanisms for landing legs and control surfaces and manufacture large scale ground demonstrators and test them.
- To develop an appropriate Thermal Protection System (TPS) for the base areas of RLV configurations with retro propulsion by applying two different mounting techniques.

The overall measure of success is the development of convergent designs which combine all investigated technologies to feasible concepts of vertical landing launchers.

3. Work structure

The technical work in RETALT is grouped in the following technical work packages:

- Reference Configurations
- Aerodynamic and Aerothermal Loads
- Flight Dynamics and GNC
- Structures and TPS

The DLR is responsible for the coordination of the project, the design of the reference configurations and the assessment of the aerodynamics and the aerothermodynamic behaviour of the vehicles through wind tunnel tests and Computational Fluid Dynamics (CFD) simulations. Likewise, CFS Engineering is performing CFD simulations and is, furthermore, responsible for the dissemination and exploitation of the results of the project. The responsibilities of Elecnor Deimos are the Flight Dynamics and the development of a Guidance, Navigation and Control concept for the reference configurations. MT Aerospace is developing structural components like the landing legs and aerodynamic control surfaces and will manufacture large scale demonstrators of the structures. Almatech is designing mechanisms for the structural parts and is responsible for the conception of a Thrust Vector Control (TVC) system. Amorim Cork Composites is designing the Thermal Protection System (TPS) for critical structural parts, especially the base area of the launchers which will be tested in hot plume wind tunnel tests at the DLR.

The key technologies studied and the target TRL that will be reached within the project for these technologies are shown in Table 1.

Table 1: Technologies investigated in RETALT and target TRL

Technology	TRL
Aerodynamic and aerothermodynamic databases for launch vehicles with flow-flow and flow-structure interaction influenced by retro propulsion	5
GNC concepts for the relevant part of the descent and landing trajectory	3
Deployable control surfaces and landing structures under high aerodynamic and landing loads	5
Thermal protection of critical structural parts (e.g. the vehicle base), considering the new application requirements	5

4. Context in relation to other European Projects

In Europe various research projects investigating RLV with retro propulsion have started in the last years. Examples are the following projects: EAGLE, FROG, DTV, CALLISTO, RETPRO and ENTRAIN. Although these projects share a common goal of building up the necessary know-how in making vertical landing reusable launch vehicles state-of-the-art in Europe, their focus and nature differ. In this section the RETALT project will be set into relation to existing European projects towards retro-propulsion assisted landing.

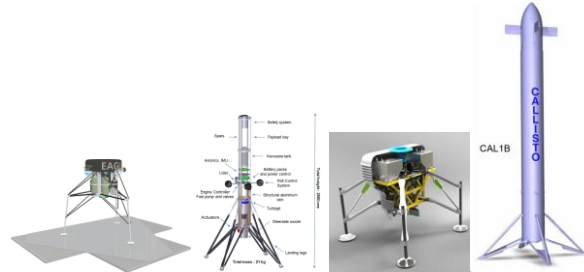

Fig. 1. European projects of retro propulsion from left to right: EAGLE [4], FROG [5], DTV [6], CALLISTO [7]

EAGLE (DLR), FROG (CNES) and the DTV (INCAS, ESA) are small scale demonstrators to investigate control laws for retro-propulsion. [4] [5] [6]

CALLISTO is a trilateral collaboration of CNES, DLR and JAXA with the goal of the development, building and demonstration of technologies for retro propulsion and reusability. It is a demonstrator with a diameter of 1.1 m and a length of approx. 13 m. [7]

RETPRO is a DLR project funded in the frame of ESA FLPP, focused on the validation of wind tunnel tests and CFD techniques for the application to retro-propulsion problems for commercially relevant trajectories of operational reusable launch vehicle. [8]

ENTRAIN is a DLR internal project focusing on the comparison of reusable VTVL and VTHL configurations on system level. [9]

Considering the aims of the different European projects provides an insight to the positioning of

RETALT in the current research. Small scale demonstrators (EAGLE, FROG, DTV) provide the possibility of an accelerated way of testing and development of systems for retro propulsion as new developments can be easily implemented in the demonstrators. Projects like RETPRO lay the foundation for specific technologies, and larger scale demonstrators (CALLISTO) provide the opportunity to prove the technologies and collect know-how for an application, which is closer to the full scale launcher. System studies like ENTRAIN analyse application scenarios and give an insight in the possibilities of the application of the technologies in future launchers.

RETALT complements these projects. It focuses on selected key technologies as summarized in the objectives of the project. As no full scale demonstrator will be built, the reference configurations can be designed in a way to optimally combine the technologies under investigation as there are no practical limits for the configurations e.g. flight altitude, Mach number and manufacturing issues. However, the ground testing in wind tunnel facilities and the structural and mechanical testing of demonstrators of landing legs and aerodynamic control surfaces in a scale (approx. one half) enable the validation of the developed designs and the achievement of high TRLs. Therefore RETALT is more focused on the development of specific technologies, in view of an in orbit validation (IOV) and in orbit demonstration (IOD) in the future.

In combination with CALLISTO, scaling effects of the demonstrator size to an operational launch vehicle can be analysed. The design of the RETALT reference configurations are technology driven. Instead of a top down methodology of defining a launcher for a specific payload, the reference launchers are designed for an optimized interaction of the technologies for retro propulsion assisted landing; leading to feasible designs with realistic payloads. Projects like ENTRAIN are therefore complementary to RETALT as they provide application scenarios and the know-how for critical assessments of the technologies developed in RETALT.

5. Reference Configurations

In this section the reference configurations are presented on the basis of which key technologies will be investigated in RETALT.

5.1. RETALT1

5.1.1. Configuration Layout

RETALT1 is a Two Stage to Orbit (TSTO) Vertical Take-off Vertical Landing (VTVL) RLV (see Fig. 4). It is similar to the Falcon 9 by SpaceX or New Glenn by

Blue Origin. However, it is based solely on European technologies. The mission requirements for RETALT1 are to transport a payload of 20 tons to a Low Earth Orbit (LEO) of approximately 340km. The current design can carry 14 t in the Geostationary Transfer Orbit (GTO).

To reduce costs and risks, and for a faster market readiness of the technologies to be developed, the selected reference configuration is based on available propulsion technologies. For this reason engines using liquid oxygen and hydrogen (LOX/LH₂), are selected, which are similar to the Vulcain 2 engine, with adjusted expansion ratios for optimum thrust of the two stages. The first and the second stage have the same type of rocket engines.

- **First Stage:** The first stage is powered by a total of nine engines with an assumed capability of throttling for the powered descent phase of 49%. Stabilization and control is approached by a novel concept, using deployable interstage segments as control surfaces to minimize additional parts and vehicle drag in the ascent phase, enhancing the efficiency during the ascent. Damper legs deploy shortly before touchdown to cushion the final impact. A Thermal Protection System (TPS) is foreseen at the base structure and Thrust Vector Control (TVC) is additionally used for attitude control of the vehicle.
- **Second Stage:** The second stage is powered by one engine. The concept covers the capabilities of either having an expendable or reusable second stage. However, the concept of a reusable second stage will not be investigated in detail in the project.

Fig. 2 shows the outline of the RETALT1 configuration. It is a tandem configuration with integral tanks with common bulkheads. The engine layout of the first stage is shown in Fig. 3. Fig. 4 depicts the flight configurations of launch, stage separation, first stage descent and first stage landing of RETALT1.

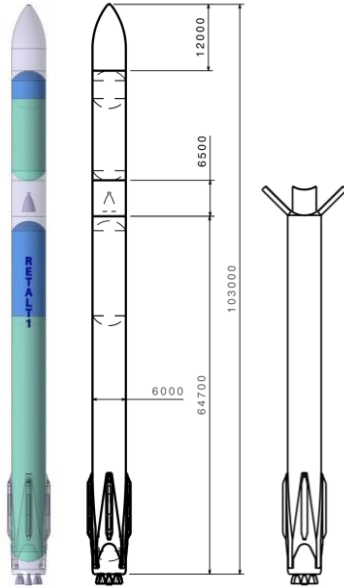

Fig. 2: Outline of RETALT1

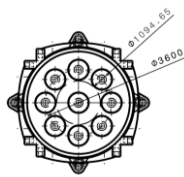

Fig. 3. Engine Layout RETALT1 first stage

Table 2. Characteristics of the RETALT1 configuration

Stage Characteristics	1st Stage	2nd Stage	Fairing	Total
Number of Engines	9	1	-	10
Reusability	+	+/-	-	+/-
Height [m]	71.2	19.8	12.0	103.0
Diameter [m]	6.00	6.00		6.00
Mass full (GLOW) [t]	680.8	204.2	2.5	899.0
Stage Rate	75.7%	24.3%		
Structure Coefficient	8.7%	8.3%		
Mass structure [t]	59.3	16.7		75.9
Propellant mass (incl. descent propellant) [t]	621.5	187.5		809.0
Descent propellant [t]	50.0	0		50.0
Propellant reserve and residuals mass [t]	7.5	2.5		10.0
Engines	RETALT1-LHLOX-E15-FS	RETALT1-LHLOX-E70-FS		
Engine Cycle	Gasgenerator	Gasgenerator		
Oxidator/Propellant	LOX/LH2	LOX/LH2		
Expansion Ratio	15	70		
Specific Impuls SL [s]	372.2	294.4		
Specific Impuls Vac [s]	401.6	431.9		
Thrust SL [kN]	9x1179 = 10614	1x930 = 930		
Thrust Vac [kN]	9x1273 = 11453	1x1364 = 1364		

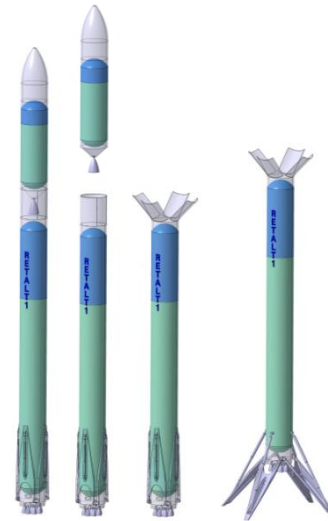

Fig. 4: RETALT1 (from left to right): launch, stage separation, first stage descent, first stage landing.

5.1.2. Configurations and Mission Events

As mentioned in the introduction of this chapter, RETALT1 is a Two Stage To Orbit (TSTO) heavy lift launcher. Therefore, the mission events of the ascent trajectory are the same as expected for expendable launchers:











After the Main Engine Ignition (MEIG-1) the launcher lifts off, accelerates and passes Q-Max. After the Main Engine Cut Off (MECO-1) the second stage is separated from the first (stage separation SEP). After the stage separation, the upper stage is accelerated further until reaching the target orbit and releasing the payload.

The first stage is recovered with the aid of retro propulsion as follows. The descent trajectory varies depending on the mission. For LEO missions, the first stage can perform a Return To Launch Site (RTL). For GTO missions Down Range Landing (DRL) on a seagoing platform can be performed.

For RTL; directly after stage separation, the first stage is turned approx. 180° around its pitch axis to fly "backwards". A toss-back burn is performed to compensate the horizontal component of the velocity and to bring the stage back near the launch site. For DRL this boost back burn is not necessary.

Hereafter, the aerodynamic control surfaces are deployed. After the vehicle reenters the denser atmosphere, a first braking maneuver is performed with three active engines (MEIG-3). After the Main Engine Cut Off (MECO-3) follows a ballistic phase. Finally, the first stage is decelerated further with the landing burn of the central engine (MEIG-4) until touchdown, while the landing legs are deployed, followed by the Main Engine Cut Off of the central engine (MECO-4).

Table 3. RETALT1 Configurations with mission events

EVENT	Aero Control Surfaces	LEGS	ACTIVE ENGINES	CONFIGURATION
Stage 1 Main Engine Ignition (MEIG-1)	Folded	Folded	9	
Lift-off	Folded	Folded	9	
Max-Q	Folded	Folded	9	
Stage 1 Main Engine Cut-off (MECO-1)	Folded	Folded	None	
Stage 2 Separation (SEP)	Folded	Folded	None	
Stage 1 Turn Around	Folded	Folded	None	
Stage 1 Main engine Boostback Burn (MEIG-2) (retrun to launch site)	Folded	Folded	3	
Stage 1 Main Engine Cut-off (MECO-2)	Folded	Folded	None	
Stage 1 Turn Around				
Stage 1 Deployment Aerodynamic Control Surfaces	Unfolded	Folded	None	
Stage 1 Main Engine Entry Burn (MEIG-3)	Unfolded	Folded	3	
Stage 1 Main Engine Cut-off (MECO-3)	Unfolded	Folded	None	
Stage 1 Main Engine Landing Burn (MEIG-4)	Unfolded	Folded	1	
Landing Legs Deployment	Unfolded	Unfolded	1	
Stage 1 Touchdown (MECO-4)	Unfolded	Unfolded	None	

5.1.3. Trajectories

For the trajectory computations preliminary aerodynamic data was obtained with Low Resolution Euler CFD computations using the DLR Flow Solver TAU, taking into account the ascent and descent configurations of RETALT1. The exhaust plume was modeled as a two gas mixture. The trajectories were computed with the DLR 3DoF trajectory simulation tool TOSCA.

The ascent trajectory is depicted in Fig. 5. It shows, that the design of the configuration and the trajectories is quite conservative with low axial accelerations and dynamic pressure.

The descent trajectories are shown in Fig. 6. The descent trajectories were computed for a Down Range Landing (DRL) of the stage after stage separation. The aerodynamic control surfaces were deflected by 45°.

Characteristics of the trajectories are:

- a first hypersonic/supersonic braking maneuver with three active engines, starting at approximately 70km with deployed aerodynamic control surfaces,
- a second subsonic braking maneuver within the landing phase close to the ground

Two trajectories were computed, which are summarized in Table 4. For both trajectories, the first braking maneuver was started at an altitude of about 70 km. However, for the first trajectory, the vehicle was slowed down to Mach 4.6, while for the second it was slowed down to Mach 3.3. Resulting from this, the second braking maneuver was started at an altitude of 1.9 km for the first trajectory and at an altitude of 1.3 km for the second trajectory. Decelerating down to Mach 3.3 with the first braking maneuver drastically reduces the dynamic pressure by about half. Therefore it seems that it is favorable to slow down the vehicle to lower Mach numbers. However, this comes at the cost of approximately 10 tons additional propellant for the deceleration. Slowing the vehicle down to Mach numbers below 3.3 increases the peak dynamic pressure again.

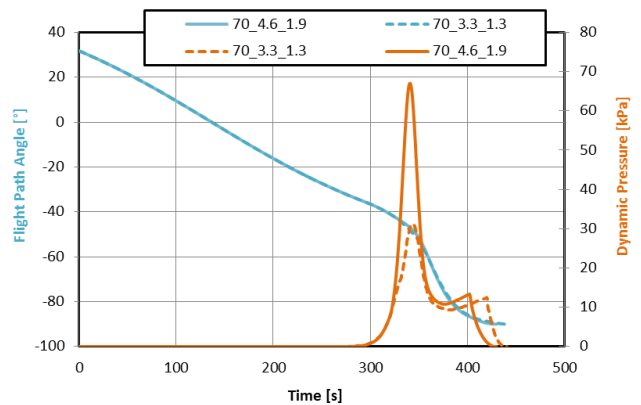
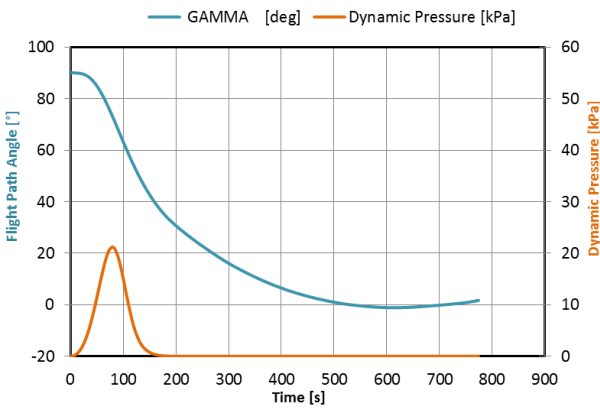
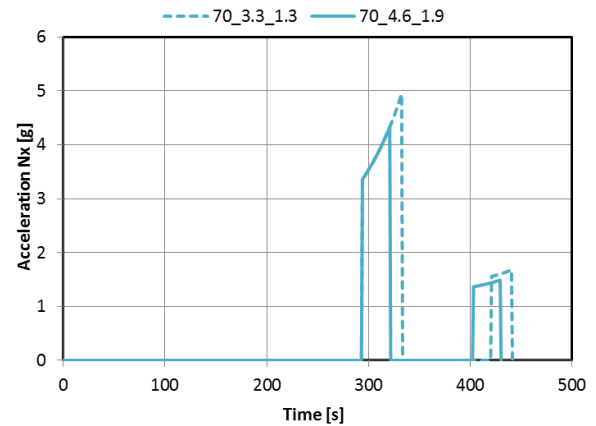
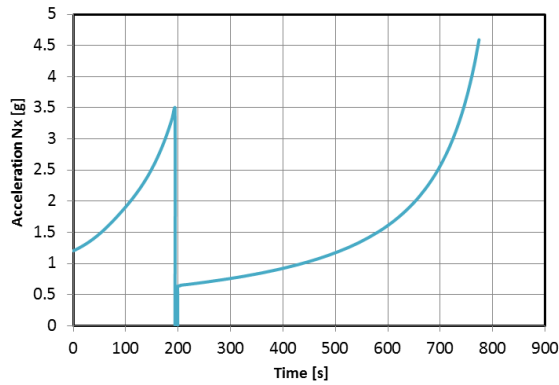
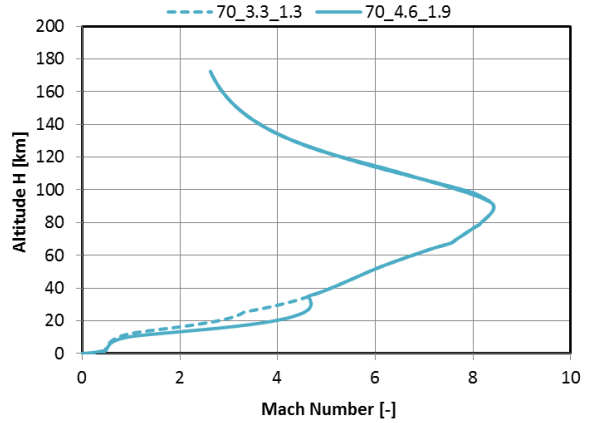
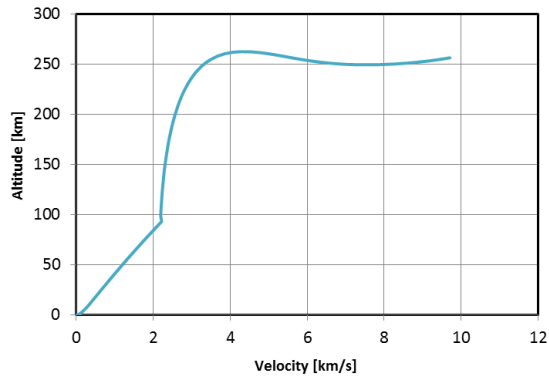

Fig. 5. Ascent trajectory of RETALT1

Fig. 6. Two selected descent Trajectories of RETALT1

Table 4. Summary of main characteristics of two selected descent trajectories of RETALT1

	Start of first braking maneuver Altitude [km]	End of first braking maneuver Mach [-]	propellant consumed [t]
Trajectory 70_4.6_1.9	70	4.6	~35.7
Trajectory 70_3.3_1.3	70	3.3	~44.8

5.2. RETALT2

5.2.1. Configuration Layout

RETALT2 is a single stage to orbit (SSTO) vertical take-off vertical landing (VTVL) RLV. It is similar to the DC-X, however, RETALT2 is primarily using European technologies. For this reason engines similar to the Vinci engine, using liquid oxygen and hydrogen (LOX/LH2), are selected with adjusted expansion ratios for optimized thrust at sea level conditions.

As it is a more novel concept, its applicability is more academic compared to RETALT1, and this vehicle can be considered a technology test bed focusing on different regimes and applications than currently operable launchers. The mission of RETALT2 is to investigate SSTO capabilities of RLV and to place smaller payloads in low earth orbits (LEO) or suborbital missions. It combines the use of retro propulsion and the novel aerodynamic control surfaces together with aerodynamic braking due to its capsule-like shape (e.g. like Soyuz, ExoMars, Hayabusa). The shaping results in a reduction of additional propellant for the descent phase and enables the use of the broad knowledge in atmospheric entry technologies existing in the consortium. This is especially true for the TPS, which is an even more crucial design element for this configuration.

Fig. 7 shows the outline of RETALT2; the engine layout is depicted in Fig. 8. Main characteristics of the configuration are summarized in Table 5.



Fig. 7. RETALT2 outline

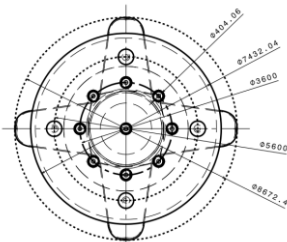

Fig. 8. RETALT2 engine layout

Table 5. Characteristics of the RETALT2 configuration

Stage Characteristics	RETALT2 properties
Number of stages	1
Reusability	+
Height [m]	17.6
Diameter [m]	7.4
Mass full (GLOW) [t]	79.4
Payload [t]	0.5
Structure Coefficient	7.4%
Mass structure [t]	5.9
Propellant mass (incl. descent propellant) [t]	73.0
Descent propellant [t]	0.4
Number of Engines	9
Engines	RETALT2-LHLOX-E8.5-FS
Engine Cycle	Expander Cycle
Oxidator/Propellant	LOX/LH2
Expansion Ratio	8.5
Specific Impuls SL [s]	370.4
Specific Impuls Vac [s]	403.9
Thrust SL [t]	9x15 = 132
Thrust Vac [t]	9x16 = 144

5.2.2. Configurations and Mission Events

RETALT2 is a Single Stage To Orbit (SSTO) Launcher for small payloads in low earth orbits with orbit inclinations nearly 0° (Kourou).

After the Main Engine Ignition (MEIG-1) the Launcher lifts off, accelerates and passes Q-Max. To limit the acceleration of the vehicle below 6 g without throttling, the Engines are shut down successively. The first phase of the ascent is performed with 9 active engines. After MECO-1/5, 5 engines remain active; followed by a phase of 3 active engines after MECO-1/3 and finally 1 active engine after MECO-1/1. Then, the vehicle reaches a stable low earth orbit and the last engine is shut down (MECO-1). The configurations and mission events are depicted in Table 6. Fig. 9 shows the ascent trajectory of RETALT2, where the cut-off of the engines can be clearly observed.

The payload is released in the orbit and (due to the nature of the configuration) the aerodynamic control surfaces are deployed at the same time. After that, the vehicle is turned approx. 180° around its pitch axis to fly "backwards". As a stable orbit of approximately 150 km is reached, a RTLS can be performed after a nearby complete orbit, followed by a trajectory similar to a Down Range Landing (DRL). A short retro boost is performed to deorbit the vehicle (MEIG-2, MECO-2). It enters the atmosphere and performs most of the reentry trajectory aerodynamically, until it is finally decelerated

with a landing boost of the central engine (MEIG-3) until touchdown; while the landing legs are deployed. Finally, the central engine is shut down (MECO-3).

Table 6. RETALT1 Configurations with mission events

EVENT	Aero Control Surfaces	LEGS	ACTIVE ENGINES	CONFIGURATION
Main Engine Ignition (MEIG-1)	Folded	Folded	9	C1: FF9
Lift-off	Folded	Folded	9	
Main Engine Cut-off (MECO-1/5)				
Main Engine Cut-off (MECO-1/3)	Folded	Folded	5	C2: FF5
Main Engine Cut-off (MECO-1/1)	Folded	Folded	3	C3: FF3
Main Engine Cut-off (MECO-1)	Folded	Folded	1	C4: FF1
Payload release / Deployment of Aerodynamic Control Surfaces	Unfolded	Folded	None	C5: UFN
Turn Around	Unfolded	Folded	None	
Main engine Deorbiting Retro-Boost (MEIG-2) (MECO-2)	Unfolded	Folded	1	C6: UF1
Aerodynamic descent phase	Unfolded	Folded	None	C7: UFN
Main Engine Landing Burn (MEIG-3)	Unfolded	Folded	1	C8: UF1
Landing Legs Deployment	Unfolded	Unfolded	1	C9: UU1
Touchdown (MECO-3)	Unfolded	Unfolded	None	C10: UUN

5.2.3. Trajectories

Fig. 9 shows the ascent trajectory of RETALT2. Also for RETALT2 the dynamic pressure keeps low, during the complete ascent. The successive shut-down of the engines can be clearly observed.

Fig. 10 shows a candidate descent trajectory of RETALT2. Only a very short retro-boost is necessary at high altitudes to deorbit the vehicle. Here it was applied shortly after the stage separation at an altitude of approx. 137 km. The re-entry of the vehicle is mainly performed aerodynamically. Shortly before touchdown at an altitude of 0.8 km, the landing burn is performed. The dynamic pressure is below 10 kPa throughout the whole descent trajectory. At the same time the acceleration on the vehicle keeps low.

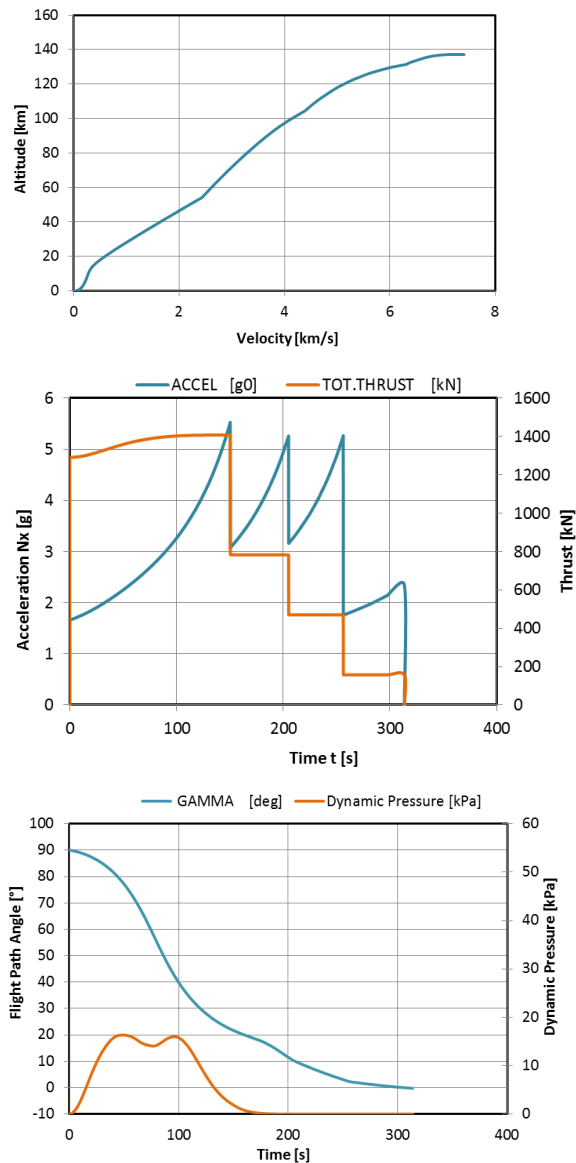

Fig. 9. RETALT2 ascent trajectory

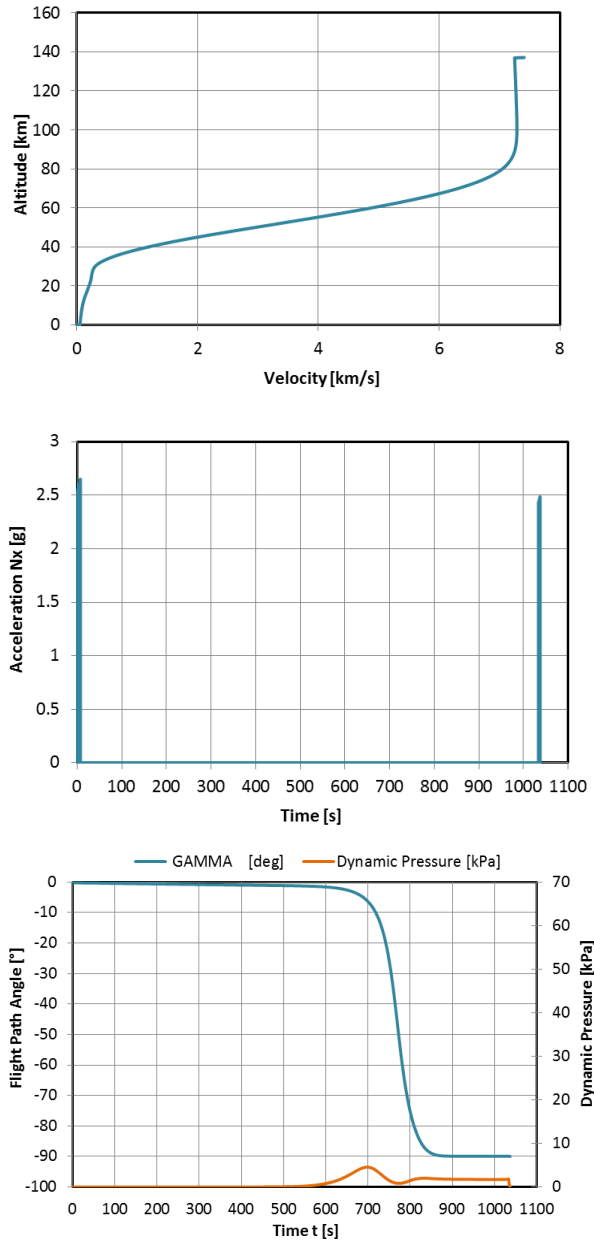

Fig. 10. Descent trajectory of RETALT2

6. Technological approach

The philosophy of the project work structure is aligned with the key technologies, to be developed. It is guided by the Reference Configurations. They define the basic conceptual constraints and technical requirements. Following these reference configurations and the respecting reference missions, Aerodynamic and Aerothermal Loads are determined from experimental and numerical simulations through DLR and CFS Engineering. They concern the relevant part of the

mission, a full model representation and a detailed model of the different aerodynamic control surfaces for the aerodynamics, as well as static ground tests for additional aerothermodynamic data. These serve as input for Flight Dynamics and GNC considerations which are performed by Elecnor Deimos and put out the additional structural loads, needed for the structural design of the launcher and its major control surface and landing structure deployment mechanisms as well as a thrust vector control mechanism by Almatech and MT Aerospace. The structures are tested with individual large scale demonstrators next to the TPS, which is developed by Amorim Cork Composites in the Structure and TPS part and is again applied to the models for aerothermal experiments within the available ground testing facilities. This interdisciplinary/multidisciplinary approach creates a full loop through all technical aspects of the project. Consequently, the main outcomes of RETALT are:

- an aerodynamic and aerothermodynamic database (AEDB/ATDB) for the different retro propulsion assisted RLV concepts RETALT1 and RETALT2,
- a GNC concept for the different retro propulsion assisted RLV concepts RETALT1 and RETALT2,
- a tested demonstrator for the deployment and deflection mechanisms and the structure of the novel concept of aerodynamic control surfaces under realistic load conditions, and
- a tested demonstrator for the deployment mechanism and the structure of the landing legs under realistic load conditions.

6.1. Ground testing and CFD for AEDB/ATDB generation

The descent of RETALT1 and RETALT2 will be simulated in experimental tests using the hypersonic wind tunnel (H2K), trisonic wind tunnel (TMK) and vertical free jet facility (VMK) of DLR in Cologne. Combining the Mach number ranges of these facilities, possible test cases can be defined for the relevant flight manoeuvres as can be seen exemplarily in Fig. 11 for the trajectory 70_4.6_1.9, described in section 5.1.3. Note that Fig. 11 shows the mapping of Mach numbers of trajectory points, that could be run in the wind tunnel facilities. However, the altitudes that can be simulated are still to be defined.

In this scope, aerodynamic tests are conducted in the H2K and TMK facilities at Mach numbers ranging from 7.0 to 1.5, using pressurized air as propulsive jet medium. In the VMK, at Mach numbers of 0.8 to 0.4, an aerodynamic stability analysis is performed under realistic plume conditions, using hot plume simulation by means of model-integrated hydrogen and oxygen (GH₂/GO₂) combustion.

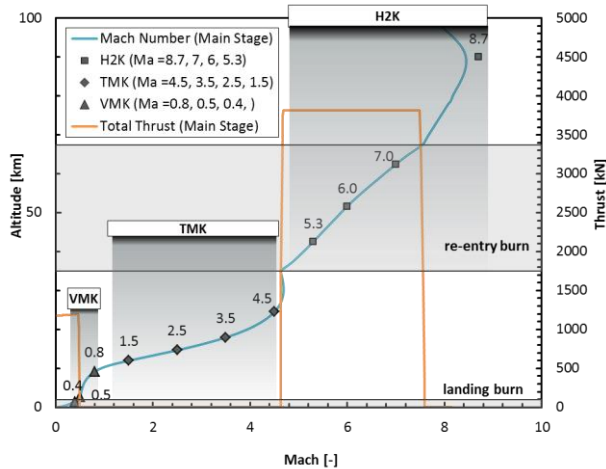

Fig. 11. Exemplary trajectory points for wind tunnel tests on trajectory 70_4.6_1.9

Also, ground effect testing for the touchdown phase with a hot plume is done using larger scale models of the launcher base in the vicinity of a ground plate to simulate the sensitivities of the pressure and temperature fields from the residual touchdown distance and the vehicles angle to the ground. Fig. 12 provides a sketch of the test setup for the base model for aerothermal ground effect testing.

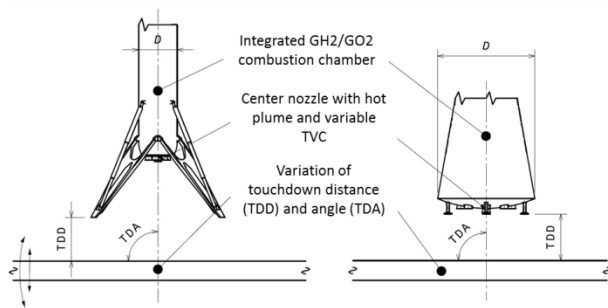

Fig. 12. RETALT1 and RETALT2 as base models for hot plume aerothermal impact tests

CFD computations with the DLR flow solver TAU and the NSMB flow solver, used by CFSE will support the wind tunnel experiments. Cross-checks between the flow solvers will, additionally, serve for the validation of the codes. The validated flow solvers will then be used together with the wind tunnel test results for the creation of the aerodynamic database and extrapolation to flight.

For the aerothermal investigations additional modelling capabilities are required. These include accurate thermo-chemical models for the exhaust jet and more rigorous requirements on boundary layer resolution and modelling for heat flux predictions. CFD analyses will be performed for all parts of the trajectory of both RETALT configurations in which significant

aerothermal loading of structural components occur. The primary goal is to provide input data for the generation of the ATDB which enables the design of thermal protection systems and the structural components investigated in the project.

Apart from the investigations in the overall aerodynamic properties of the two vehicles, dedicated wind tunnel experiments and CFD computations will be performed for the characterization and analysis of the novel approach of using the interstage (RETALT1) or fairing (RETALT2) segments as aerodynamic control surfaces.

6.2. GNC concept definition

In the RETALT project retro propulsion thrust is used to slow down the vehicle. Gliding vehicles, such as IXV, SHEFEX, or Shuttle, do not make use of thrust: the use of retro propulsion in the flight dynamic environment is the next challenge that will be addressed in RETALT, building upon the European flight experience in gliding re-entry vehicles, and also using Elecnor Deimos background on Flying Qualities (FQ) for subsonic applications (UAVs and aircrafts). This will advance European FQ capabilities, combining existing flight proven methodologies for re-entry gliders with capabilities for analyses for high thrust scenarios.

On the GNC side, a full GNC concept shall be designed, maturing and extending state-of-the-art technologies in the different fields of Guidance, Navigation and Control, and applying them to the innovative problem of VTVL RLV. The result will be an integrated GNC system which will enable the VTVL RLV mission concept at European level, delivering the performance and robustness levels required.

This will be done at the GNC subsystem level, to identify the GNC architecture, function and product trees. The latter is particular important, so as to identify the supporting hardware, in the GNC sensors, actuators and avionics (OBC), needed to support the retro propulsion innovation at a European level. For the sensors and avionics, European proven technology for re-entry vehicles can be spun-in to support the vertical landing launcher GNC needs.

In terms of the GNC algorithms, for the Guidance, online trajectory optimization using novel approaches based on a convex formulation of the problem will be employed to attain the required precision and optimise fuel consumption during the retro propulsion phase, while providing convergence guarantees. State-of-the-art in hybrid Navigation technologies will be employed for the reliable estimation of the vehicle states based on the fusion of inertial measurements together with GNSS (Global Navigation Satellite System) data (i.e., Galileo satellite constellation), together with radar altimeter information for the very last part of the landing. State-

of-the-art multi-mode scheduled controllers will be designed and verified using modern robust control techniques, such as H-infinity and mu-synthesis/analysis, in order to track the trajectory and attitude references generated by Guidance while guaranteeing the stability and the performance of the system in the presence of time-varying and parametric uncertainties affecting the complex problem of the VTVL RLV. Additionally, an Actuator Management Function will be developed in order to autonomously and on-line optimally allocate the force and torque commands coming from the controller to the different sets of the actuators (thrusters, TVC, grid fins etc.) and converting them into proper actuators inputs, depending on the current flight phase and the available actuators.

6.3. Structures, Mechanisms and TPS

The first objective of the structural analyses in the scope of the RETALT project is to develop high-level architectural concepts that can fulfil the structural duties under consideration of the aerodynamic and thermo-mechanical loads. Since these structures form key parts of re-useable launch vehicles, it will not suffice to assess the reliability but also to assess the solutions for maintainability, serviceability and commercial viability.

Consequently, the mechanisms and structures will be developed through unified and holistic working. Almatech develops the concepts for the mechanisms and thus the consequent structural requirements and MT Aerospace provides the mechanical environment and structural concepts that in turn provide requirements to the mechanisms. Almatech will handle the kinematics of deployment, MT Aerospace the loads and mechanical environment.

These efforts will also feed into the system level requirements and concepts. Ultimately, the most promising solution for a landing leg system and aerodynamic control surface system will be carried forward. One solution for the landing leg system and one solution for a control surface system will go forward to representative scale manufacture and demonstration.

Additionally, Almatech will perform a trade-off on the mechanisms and structures for thrust vector control systems (TVC), in order to define a concept which can be used on the different types of rocket engines and which answers to the RETALT requirements. The best solution will be down selected, studied and analysed until the design review level.

For the thermal isolation of critical structures of the vehicles (e.g. base plane and aerodynamic control surfaces), new thermal protection system (TPS) designs from cork materials will be studied. In addition to the standard mounting, a sputtering technique will be applied for cost efficient TPS. Detailed analyses will

give insight in the requirements of TPS systems for launch vehicles with retro propulsion e.g. the required thickness and adhesion. The TPS will be applied to the wind tunnel models for the hot plume wind tunnel tests in the VMK test facility at DLR in Cologne.

7. Conclusions

In conclusion RETALT is a multidisciplinary European project with the goal to provide the foundations and the physical understanding for the application of technologies for retro propulsion assisted landing. It is focused on the fields of aerodynamics, aerothermodynamics, flight dynamics and GNC, structures, mechanisms, TVC and TPS.

The aim is not only to generate detailed know-how in key technologies, but also to complement existing European projects in this field of research. Due to extensive dissemination throughout the whole project life time, not only the European, but the global space research and industry can profit from experiences gained with demonstrators, wind tunnel experiments and high fidelity CFD.

Acknowledgements

This project has received funding from the European Union's Horizon 2020 research and innovation framework program under grant agreement No 821890. We gratefully acknowledge the interest in our work and the opportunity to forward this essential research.

References

- [1] P. Starke, C. Dorbath, D. Zell; "*Design and Manufacturing Status of Advanced Structures for Reusable Launch Systems Demonstrators with Retro Propulsion Assisted Landing Technologies (RETALT)*" IAC 2019, 70th International Astronautical Congress, Washington D.C., USA, 2019, 21–25 October.
- [2] H2020-SPACE-2018-2020, "Access to space", Oct 27, 2017, <https://ec.europa.eu/info/funding-tenders/opportunities/portal/screen/opportunities/topic-details/space-16-tec-2018>
- [3] Communication from the Commission to the European Parliament, the Council, the European Economic and Social Committee of Regions, "*Space Strategy for Europe*", Brussels, 2016
- [4] M. Dumke, S. Theil, "*Auto-Coded Flight Software for the GNC VTVL Demonstrator EAGLE*", 8th European Conference for Aeronautics and Space Sciences, 1-4 July 2019, Madrid, Spain

- [5] B. Rmili, D. Monchaux, O. Bosineau, J. Hassin, S. Querry, S. Besson, G. Poirey, R. Boré, I. Hamada, H. Amrouchi, J. Franc M. Barreau, N. Mercadié, T. Labois, D. Grinco, “*FROG, a Rocket for GNC demonstrations: Firsts flights attempts of the FROG turbojet version and preparation of the future mono-propellant rocket engine*”, 8th European Conference for Aeronautics and Space Sciences, 1-4 July 2019, Madrid, Spain
- [6] A.-M. Neculaescu, A. Marin, A. Toader, A.-G. Persinaru, A.-M. Cismilianu, M. Tudose, C.-E. Munteanu, I. Popescu, H. Strauch, S. Dussy, “*System Identification and Testing for a VTVL vehicle*”, 8th European Conference for Aeronautics and Space Sciences, 1-4 July 2019, Madrid, Spain
- [7] E. Dumont, T. Ecker, C. Chavagnac, L. Witte, J. Windelberg, J. Klevanski, S. Giagkozoglou, „*CALLISTO – Reusable VTVL launcher first stage demonstrator*“, Space Propulsion Conference, 14 – 18 May 2018, Seville, Spain
- [8] D. Kirchheck, A. Marwege, J. Klevanski, J. Riehmer, A. Gülhan, S. Karl, O. Gloth, „*Validation of Wind Tunnel Test and CFD Technologies for Retro-Propulsion (RETPRO): Overview of a Project within the Future Launcher Preparatory Programme (FLPP)*“, International Conference on Flight Vehicles, Aerothermodynamics and Re-entry Missions & Engineering, 30 September – 3 October 2019, Monopoli, Italy
- [9] S. Stappert, J. Wilken, L. Bussler, M. Sippel, S. Karl, J. Klevanski, C. Hantz, D. Krause, H. Böhrk, L. Evrim-Briese, “*European Next Reusable Ariane (ENTRAIN): A Multidisciplinary Study on a VTVL and a VTHL Booster Stage*”, 70th International Astronautical Congress, 21 - 25 October 2019, Washington D.C., USA