

Winter 1-31-1994

## Analysis for handling flexible green sheets with automated tools

Chao Xie  
*New Jersey Institute of Technology*

Follow this and additional works at: <https://digitalcommons.njit.edu/theses>



Part of the [Mechanical Engineering Commons](#)

---

### Recommended Citation

Xie, Chao, "Analysis for handling flexible green sheets with automated tools" (1994). *Theses*. 1707.  
<https://digitalcommons.njit.edu/theses/1707>

This Thesis is brought to you for free and open access by the Electronic Theses and Dissertations at Digital Commons @ NJIT. It has been accepted for inclusion in Theses by an authorized administrator of Digital Commons @ NJIT. For more information, please contact [digitalcommons@njit.edu](mailto:digitalcommons@njit.edu).

## **Copyright Warning & Restrictions**

The copyright law of the United States (Title 17, United States Code) governs the making of photocopies or other reproductions of copyrighted material.

Under certain conditions specified in the law, libraries and archives are authorized to furnish a photocopy or other reproduction. One of these specified conditions is that the photocopy or reproduction is not to be “used for any purpose other than private study, scholarship, or research.” If a user makes a request for, or later uses, a photocopy or reproduction for purposes in excess of “fair use” that user may be liable for copyright infringement,

This institution reserves the right to refuse to accept a copying order if, in its judgment, fulfillment of the order would involve violation of copyright law.

**Please Note: The author retains the copyright while the New Jersey Institute of Technology reserves the right to distribute this thesis or dissertation**

Printing note: If you do not wish to print this page, then select “Pages from: first page # to: last page #” on the print dialog screen

The Van Houten library has removed some of the personal information and all signatures from the approval page and biographical sketches of theses and dissertations in order to protect the identity of NJIT graduates and faculty.

## ABSTRACT

### ANALYSIS FOR HANDLING FLEXIBLE GREEN SHEETS WITH AUTOMATED TOOLS

by  
Chao Xie

The electronics industry is characterized by rapid technological advances. Increase in number of I/O interconnections on chips and need for more compact assemblies is forcing designer to consider multilayer ceramic packaging. With the advancement in co-fired technology, the green tapes are becoming widely used now, and will be even more so in the future. There is considerable knowledge and expertise on the preparation of multilayer ceramic materials but little information is available on the handling of laminate ceramic green sheets with automated tools.

In this thesis, we will analyze the displacement, the principal and shearing stress of the different sized laminated green sheets when they are handled by either two-holder or four-holder pick-up tools. The analysis was carried out with the FEM modules in the I-DEAS package. The results are used to study the different influence of the two-holder and four-holder pick-up tools.

A conceptual design for adjustable four-holder pick-up tool was proposed for handling and stacking the laminated multilayer ceramic green sheets.

**ANALYSIS FOR HANDLING FLEXIBLE GREEN SHEETS  
WITH AUTOMATED TOOLS**

by  
**Chao Xie**

**A Thesis  
Submitted to the Faculty of  
New Jersey Institute of Technology  
in Partial Fulfillment of the Requirements for the Degree of  
Master of Science in Mechanical Engineering**

**Department of Mechanical and Industrial Engineering**

**January 1994**

**Robert W. Van Houten Library  
New Jersey Institute of Technology  
Newark, New Jersey 07102**

Blank Page

APPROVAL PAGE

ANALYSIS FOR HANDLING FLEXIBLE GREEN SHEETS  
WITH AUTOMATED TOOLS

Chao Xie

---

Dr. ~~Zhiming~~ Ji, Thesis Adviser Date  
Assistant Professor of Mechanical Engineering, NJIT

---

Dr. Bernard ~~Koplik~~, Committee Member Date  
Professor of Mechanical Engineering and  
Chairperson of the Department of  
Mechanical and Industrial Engineering, NJIT

---

Dr. Benedict C. Sun, Committee Member Date  
Associate Professor of Engineering Technology and  
Program Coordinator of Mechanical Engineering Technology, NJIT

## BIOGRAPHICAL SKETCH

**Author:** Chao Xie  
**Degree:** Master of Science in Mechanical Engineering  
**Date:** January, 1994

### **Undergraduate and Graduate Education:**

- Master of Science in Mechanical Engineering,  
New Jersey Institute of Technology,  
Newark, New Jersey, U.S.A., 1994
- Bachelor of Science in Materials Science and Engineering,  
Shanghai Jiao Tong University,  
Shanghai, P. R. China

**Major:** Mechanical Engineering



**Thesis is dedicated to my parents**

## ACKNOWLEDGMENT

The author wishes to express his sincere gratitude to his thesis advisor, Professor Zhiming Ji, for his guidance, friendship, and support throughout this work.

Special thanks to Professors Koplik and Sun for serving as members of the committee.

The author is grateful to the Mechanical Engineering Department of NJIT for support of this work. And thank you to Professor Herman for his help.

The author sincerely wishes to thank his friend: Mr. Tianzong Xu, Mr. Wenge Yang and Mr. Shenli Cui.

And finally, the author would like to express his special gratitude to his parents, his sponsor Mr. William Fu and Miss Kathy Zhou for their care and support for my study in the United States of America.

## TABLE OF CONTENTS

Chapter	Page
1 INTRODUCTION.....	1
1.1 The Problem Of Current Tools.....	1
1.2 Thesis Overview .....	2
2 MULTILAYER CERAMIC PACKAGE AND LAMINATE PROPERTIES .....	3
2.1 Development Of Multilayer Ceramic Package .....	3
2.2 Green Sheet Personalization .....	7
2.3 Fabrication.....	8
2.4 Density.....	11
2.5 Mechanical Properties.....	11
2.6 Strength and Elasticity.....	12
3 ANALYSIS STRESS AND DISPLACEMENT OF THE GREEN SHEET.....	18
3.1 The General Structure of Finite Element Module In I-Deas.....	18
3.2 Data Entry Module In I-Deas.....	20
3.2.1 Size of Laminate.....	21
3.2.2 Size of Element.....	21
3.3 Material Properties Set.....	22
3.3.1 Density.....	22
3.3.2 Weight of Laminate.....	23
3.3.3 Node Fore.....	24
3.3.4 Module of Elasticity.....	25
3.4 Boundary Definition.....	25
3.5 Case Set.....	26

**TABLE OF CONTENTS**  
( Continued )

<b>Chapter</b>	<b>Page</b>
3.6 Solution and Post Processing.....	26
3.6.1 Analysis of System-3081.....	27
3.6.2 Analysis of System-3080.....	28
3.7 Comparison of Mesh Size Numbers.....	29
3.8 Compare With Two-Holder Pick-Up Tool.....	35
3.8.1 Restraint Set.....	35
3.8.2 Case Set.....	35
3.8.3 Result.....	35
3.9 Comparison of Setting Position in System-3081.....	42
3.10 Discussion.....	46
3.10.1 The Maximum Principal Stress Theory.....	47
3.10.2 The Maximum Shear Stress Theory.....	50
4 CONCEPTUAL OF FOUR-HOLDER PICK-UP TOOL.....	52
5 RECOMENDATIONS.....	55
APPENDIX.....	56
WORKS CITED.....	84

## LIST OF TABLES

Table	Page
2.1 Logic Interconnections.....	7
2.2 Wiring Length.....	7
2.3 The Densities of Some Kinds of Glass-Ceramic Materials .....	12
2.4 Bending Strength.....	14
2.5 Young's Modules.....	14
2.6 Bending Strength of Various Types of Glass-Ceramic Material.....	15
2.7 System of Laminate.....	16
2.8 Green Sheet ( Unfired ) Properties.....	17
3.1 Different Data of System-3081 in Different Meshes.....	35
3.2 Different Data of System-3080 in Different Meshes.....	35
3.3 The Factor of Safety in The Maximum Principal Stress Theory.....	49

## LIST OF FIGURES

<b>Figures</b>	<b>Page</b>
2.1 35 and 50 mm Mulichip Modules.....	3
2.2 64 mm Air-Cooled Module .....	4
2.3 Thermal Conduction Module .....	5
2.4 Stacking .....	9
2.5 Lamination .....	9
2.6 Sizing .....	9
2.7 Sintering.....	10
2.8 TCM Substrate Shrinkage.....	10
2.9 System-3081 and System-3080 .....	15
2.10 Module Structure .....	16
2.11 Dimensional Requirements on Via Punch Blank .....	17
3.1 The Idea of Pick-Up Tool.....	19
3.2 Flow Chart of the Operation of a Finite Element Program.....	20
3.3 Different Meshes.....	22
3.4 Two-Dimensional Mesh.....	23
3.5 Node Force of Green Sheet.....	25
3.6 Displacement Plot Of Case 1.....	30
3.7 Stress Plot of Case 2.....	31
3.8 Displacement Plot of Case 3.....	32
3.9 Stress Plot of Case 4.....	33
3.10 Displacement Plot of Case 5.....	38
3.11 Stress Plot of Case 6.....	39
3.12 Displacement Plot of Case 7.....	40
3.13 Stress Plot of Case 8.....	41

**LIST OF FIGURES**  
( Continued )

<b>Figures</b>	<b>Page</b>
3.14 The Setting Position in System-3081.....	43
3.15 The Stress of New Position.....	44
3.16 The Displacement of New Position.....	45
3.17 Special Nodes on Green Sheet.....	46
4.1 Robots of Material Handling.....	52
4.2 Frame of the Pick-Up Tool.....	53
4.3 Mechanism of Pick-Up Tool.....	54

# CHAPTER 1

## INTRODUCTION

Multilayer ceramic devices are becoming increasingly important in several key electronic applications. Multilayer ceramic capacitors are helpful in reducing the size of electronic circuitry. These capacitors are used extensively in computers, telephones, and many other applications. Multilayer ceramic packages are used to house electronic circuitry in a small, hermetically sealed volume which improves reliability and increases circuit speed in many important applications [ 13 ].

In addition to being a materials challenge, multilayer ceramic devices are also a manufacturing challenge. As an example, IBM has expended a great deal of money and effort in perfecting the manufacture of their multilayer chip carrier [ 13, 14 ]. The key challenge was to improve in not only performance but also cost and reliability. Use of effective tooling is one of the important approaches to achieve this goal.

### 1.1 The Problem of Current Tools

Multilayer ceramic substrate is composed of a number of individual ceramic layers. For example, the IBM system-3080 is composed of 33 layers and system-3090 is composed of 36-45 layers [ 10 ]. Each layer is patterned with metal lines on its surface and metal filled via holes for distributing signal and power within the layer, and from layer to layer [ 5 ]. The basic building block used in the multilayer ceramic process is the " laminated ceramic green sheet " which is mixture of ceramic and glass powder suspended in an organic binder. The individual layers of a multilayer substrate ( in unfired state ) can be produced separately, then stack-laminated and fired together. A more detailed discussion of this process is given in chapter 2.



The laminated green sheets are thin and flexible, their size is small, ranging from  $90 \times 90 \text{ mm}^2$  to  $200 \times 200 \text{ mm}^2$ . Those individual layers need to be precisely aligned when they are stacked together to form the multilayer substrates. Although special tools have been developed for most of other processes, the inter-process handling and stacking of green-sheets are essentially performed with manual labors. Since the green sheets are flexible and small in size, it is difficult to handle them with automated tools.

## 1.2 Thesis Overview

This thesis explores the feasibility of using robotized tools to handle the ceramic green sheets in production line. We want to develop a tool that can be used as an end-effector of a robot to hold and place green sheets of various sizes. Handling green sheets includes transporting them among different processing machines, loading and unloading, and presenting them for alignment during stacking. The stress and deformation of green sheets need to be controlled to avoid damage from movement and to ensure precise alignment.

Our objectives are first to establishing a good understanding of the stress and deformation of green sheets under various handling conditions and then to develop the tools that can be easily adopted by conventional pick-and-place machines and assembly robots.

Chapter two describes the laminating process and properties of green sheets. Several multilayer ceramic modules developed by IBM corporation are introduced.

Chapter three describes the analysis of stress and displacement of green sheet. The Finite Element Method in I-DEAS software was selected as a tool for the analysis.

Chapter four describes the conceptual design of an adjustable handling tool for green sheets.

Chapter five summarizes the work presented in thesis in the thesis and discusses some areas for future work.

## CHAPTER 2

### MULTILAYER CERAMIC PACKAGE AND LAMINATE PROPERTIES

#### 2.1 Development of Multilayer Ceramic Package

In current microelectronics package market, a number of companies have the capability to manufacture multilayer ceramic MCMs, such as IBM, GE, NTK, KYOCERA, NEC [ 10 ]. The advancement of multilayer ceramic packaging technology may be illustrated through the development of multilayer ceramic modules at IBM, as an example, IBM introduced its first multichip module ( MCM ) in 1979 for the 4300 series of intermediate processors [ 1, 2, 4, 5 ].

These modules, shown in ( Fig 2.1 ), are 35 and 50 mm square and provide the capability to mount up to nine LSI chips, providing a 2× increase in circuit or bit packaged density over previous single-chip module designs. These packages have allowed for significant reductions in wiring length and the number of interpackage connections, resulting in performance and reliability improvements.

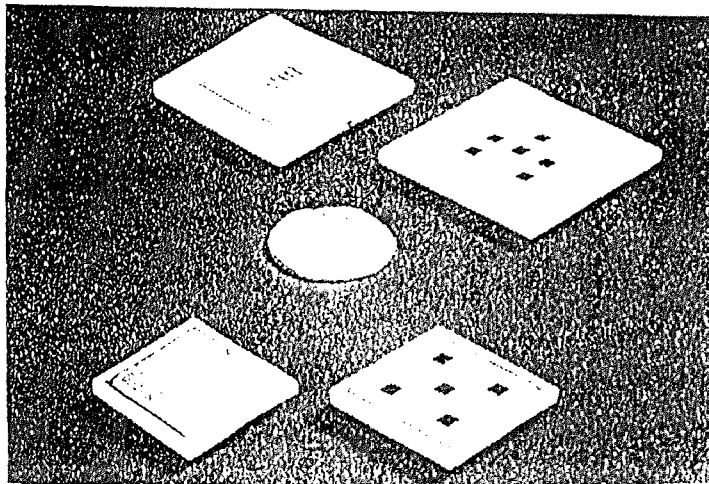
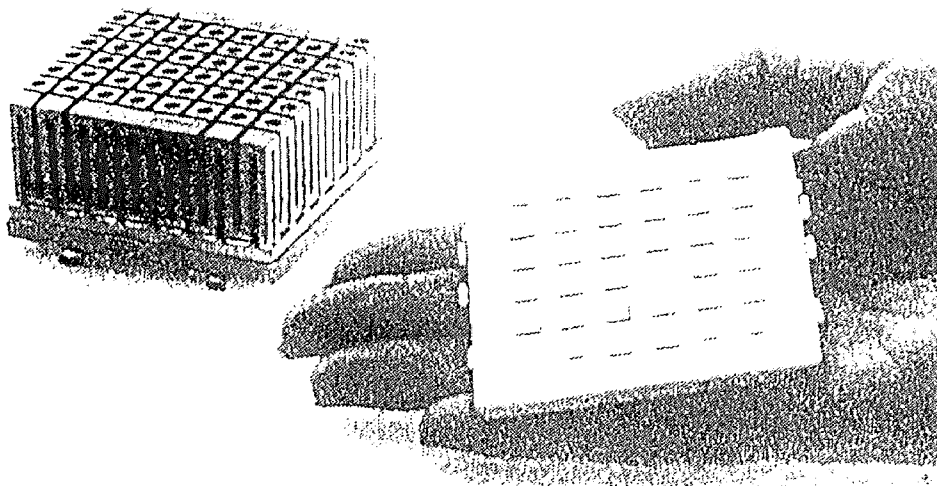

Figure 2.1 35 and 50 mm Multichip Modules

The 35 and 50 mm modules use a substrate consisting of up to 22 ceramic metallized layers for interconnecting the LSI devices and I/O pins. A typical 35 or 50 mm module can support 4000 circuits and provides a maximum cooling capability of 9W.

In 1983, IBM announced a new processor for the mid-range 4300 Series computer systems, The IBM-4381. This system utilizes a 64 mm air-cooled multilayer ceramic module with up to 36 advanced LSI logic and array chips. This package ( Fig. 2.2 ) is a major factor in the significant price and performance improvements of the 4381 over earlier 4300 Series computers. The multilayer ceramic substrate has up to 32 layers and provides the power distribution and wiring to support over 20,000 logic circuits or 32,000 array bits.

A key feature of the 64 mm module is the ability to dissipate up 85 watts. The design includes the use of thermal grease between the chip and cap and a unique heat sink assembly. At the system level, impingement cooling is utilized to direct air perpendicular to each module. These enhancements allow for approximately three times the power density over previous IBM air-cooled packages.



**Figure 2.2** 64 mm Air-Cooled Module

In 1980, IBM announced the thermal conduction module ( TCM ) used in the 3080X systems. This module ( Fig. 2.3 ) is approximately 150 by 150 by 60 mm in size and

provides the capability to mount up to 100 LSI logic chips or up to 133 LSI logic and array chips. Typically, a TCM contains 30,000 logic circuits and 65,000 array bits. The TCM has been designed to handle thermal loads of up to 300 W/module. It is constructed to be pluggable with 1800 simultaneous connections to a large organic printed circuit board by means of an IBM-designed connector assembly.

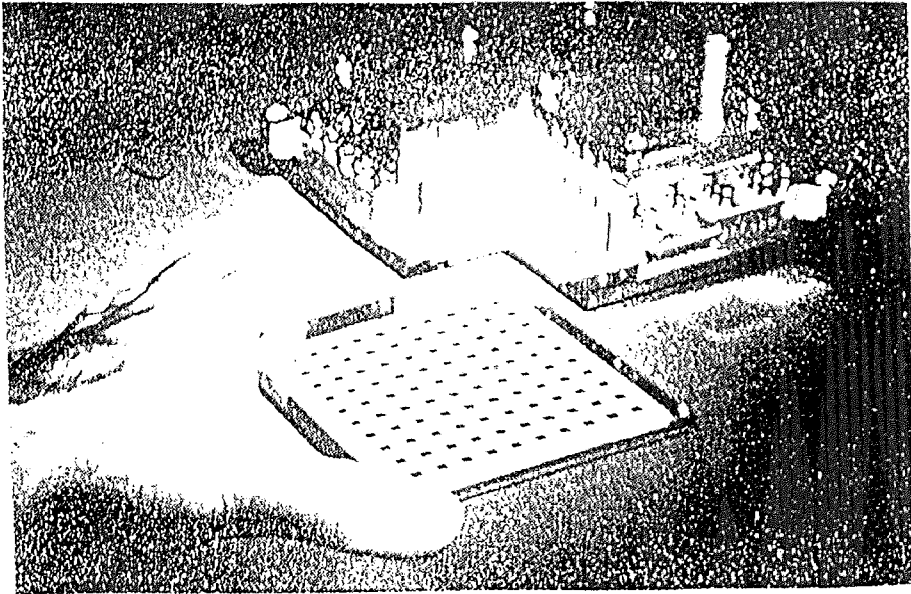

Figure 2.3 Thermal Conduction Module

The significance of the thermal conduction module coupled with LSI semi-conductors is apparent, considering that the TCM allows for a level of logic partitioning at the module level that was previously accomplished at the gate level. A typical TCM replaces many single-chip modules, printed circuit card, boards, and cables required in earlier IBM systems.

The large reduction in hardware results in an order of magnitude reduction in packaging interlevel connections, which in turn results in a significant improvement in system reliability. The table 2.1 shows the number of interconnections for two TCMs. Further, logic wiring length ( Table 2.2, in meter ) is reduced at all level of packaging

compared to earlier technologies. Wiring length reduction is a significant factor in performance improvement in the 3080X systems.

**Table 2.1.** Logic Interconnections

	<u>SYSTEM 3033</u>	<u>SYSTEM 3081</u>
CHIP	13 LOGIC GATES	915 LOGIC GATES MAX
MODULE	SINGLE CHIP	100 CHIPS
<u>CONNECTIONS</u>		
*CHIPS TO MODULE	22560	4368
*MODULE TO CARD	22560	670
*CARD TO BOARD	4000	670
	-----	-----
TOTAL	49120/TCM	5038/TCM
	EQUIVALENT	

**Table 2.2** Wiring Length

	<u>SYSTEM 3033</u>	<u>SYSTEM 3081</u>
CHIP LEVEL	30M	25M
MODULE/CARD LEVEL	935M	130M
BOARD/CABLE LEVEL	1440M	150M
	-----	-----
TOTAL	2405M/TCM	305M/TCM
	EQUIVALENT	

## 2.2 Green Sheet Personalization [ 13 ]

In multilayer ceramic modules, metal filled via holes used to provide connection between layers. These via holes must be to the size and positional tolerances needed to ensure electric integrity within the substrate in its completed fired state. Punch machines are used to produce the via holes. Four corner location holes position the ceramic layer over pins on a pallet that is an integral part of a precision X-Y table. The X-Y table moves the green sheet under a stationary multiple punch and die set operating at high speed. Each punch in the cluster is actuated by a solenoid, allowing for personalized hole patterns to meet individual layer requirements. The punch equipment also includes an inspection station consisting of a collimated high light source and array of photo diodes to verify the accuracy of the hole pattern.

The next step is metalization, which is a process for generating metal lines on the surface of green sheets. Paste, used for metalizing the layers, consists of conductive powder mixed with a resin, solvent, and other additives. The composition is not the same for all layers and is selected to make the proper trade-off between conductivity, metal shrinkage, and screening properties. Likewise, the paste vehicle is varied to account for pattern differences and extent of metallization.

The punched green sheet is positioned on the screener using the same four location holes used in punching. A traversing paste reservoir and nozzle assembly, forces paste through a metal mask which is in direct contact with the green sheet, filling the via holes and defining the layer pattern.

The top surface pattern consists of metallized vias for C-4 ( controlled collapse chip connection )-to-substrate connections. There is also an array of pads surrounding each chip site for electrical testing and attachment of engineering change wiring. Typically, redistribution, signal, and reference planes are screened with fine lines and spaces. Power planes are metallized over the total surface, except for clearance rings surrounding vias

where electrical isolation is needed on the bottom layer there is an array of pads used for brazing I/O pins in place.

After screening, the metallized sheets are dried. The optimized drying cycles are carefully controlled to maintain required green sheet properties.

One of the advantages of the multilayer ceramic process is the ability to inspect sheets prior to stacking and lamination. Precise inspection of individual layers is critical to downstream yields. The inspection equipment is based on a character-recognition principle. A scanning laser is directed on the metallized surface and the reflected light is directed to a photo multiplier tube. The voltage levels generated distinguish the darker paste from the ceramic background.

### **2.3 Fabrication [ 11 ]**

Inspected layers are stacked on a pinned fixture using the four corner location holes in each green sheet ( Fig. 2.4 ). The stacking fixture is mounted on a die ( Fig. 2.5 ), which is an integral part of the lamination press. The lamination die is precision-machined and assembled to ensure parallelism and flatness, which are critical to achieving uniform green density and shrinkage during sintering. During lamination, the layers are sheared from the stack and compressed.

The green laminate is then cut with a carbide saw, as shown in Fig. 2.6. The laminate is aligned using an X-Y table and held in place with vacuum. For some products, individual layers are cut to exact green dimensions and stacked in a lamination die. This procedure eliminates the post-lamination sizing step.

Substrates are sintered in either batch or continuous kilns. During sintering the substrates are supported on suitable surfaces ( Fig. 2.7 ) to achieve flatness and to ensure uniform temperature throughout the sintering cycle.

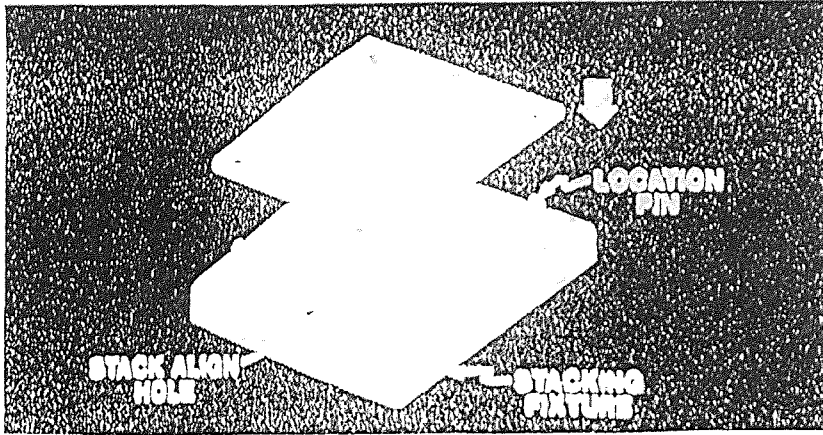

Figure 2.4 Stacking

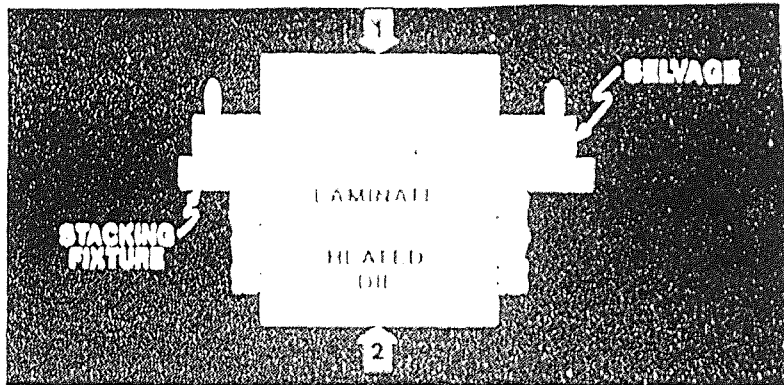

Figure 2.5. Lamination

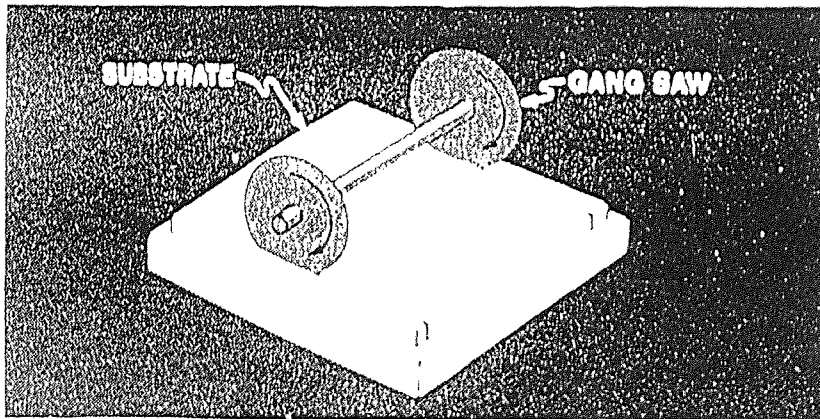

Figure 2.6 Sizing



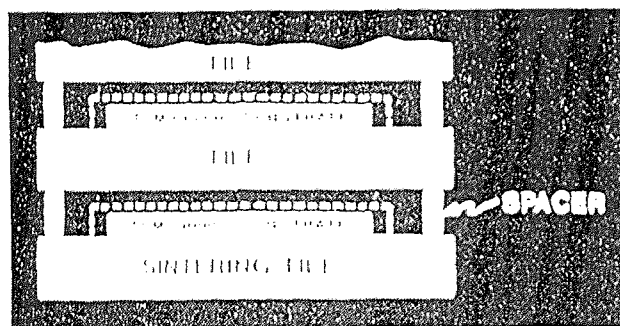

Figure 2.7 Sintering

The firing process has been optimized to ensure accurate control of shrinkage, which is necessary for achieving the dimensional control for further processing. In addition, the sintering cycle has been defined to reach high densification of the ceramic-glass-metal composite.

During the initial phase of sintering in a hydrogen environment, residual solvents and organic materials start to decompose. As temperature is increased, moisture is added to accelerate oxidation of residual carbon. Sintering and densification of the ceramic/metal composite start before the peak temperature is reached. A controlled cooling cycle follows to complete the process. A dramatic dimensional change occurs during sintering, as illustrated in Fig. 2.8.

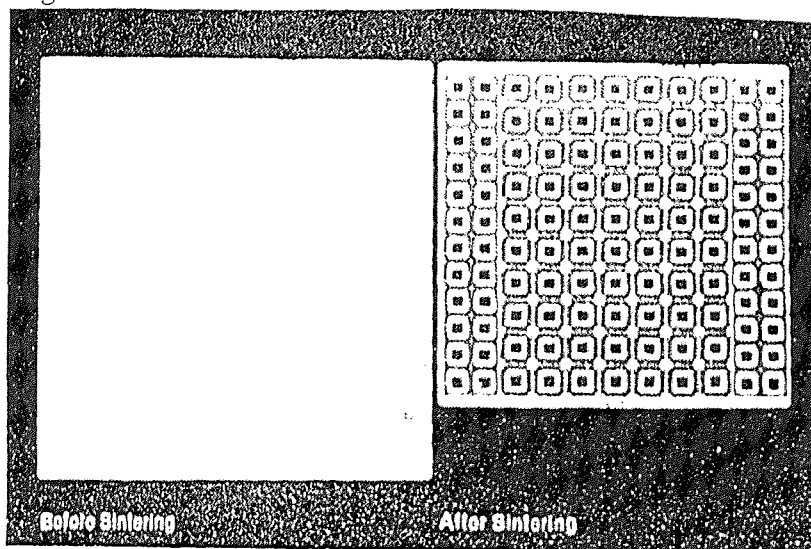

Figure 2.8 TCM Substrate Shrinkage

## 2.4. Density [ 14 ]

The density of glass-ceramic materials is an additive function of the densities of the crystalline and glass phases present. Mostly, however, it is determined by the density of the main crystalline phase. Consequently, the individual types of glass-ceramic materials exhibit characteristic density values. The densities of some glass-ceramic substances are given in Table. 2.3. The density of parent glass-ceramic material is very often different, because volume changes usually occur during the heat treatment. These changes show positive, zero or negative values but they do not usually exceed 3 vol.%.

**Table 2.3** The Densities of Some Kinds of Glass-Ceramic Materials [11]

Basic System	Density range ( $\text{kg/m}^3$ )
$\text{SiO}_2\text{-Na}_2\text{O, K}_2\text{O}$	2290-2370
$\text{SiO}_2\text{-Li}_2\text{O}$	2390-2460
$\text{SiO}_2\text{-Al}_2\text{O}_3$	2390-2510
$\text{SiO}_2\text{-Al}_2\text{O}_3\text{-Li}_2\text{O-TiO}_2$	2420-2570
$\text{SiO}_2\text{-Al}_2\text{O}_3\text{-MgO-TiO}_2$	2490-2680
$\text{SiO}_2\text{-Al}_2\text{O}_3\text{-CaO-TiO}_2$	2480-2800
$\text{SiO}_2\text{-Al}_2\text{O}_3\text{-BaO-TiO}_2$	2960-5880
$\text{SiO}_2\text{-Al}_2\text{O}_3\text{-ZnO-TiO}_2$	2990-3130

## 2.5 Mechanical Properties

Similar to the initial glass or ceramics, glass-ceramic substances are also brittle at room temperatures and do not exhibit ductility or plasticity, but behave as elastic substances up to the strain that produces breakage.

The mechanical strength and elasticity of glass-ceramic materials are important characteristics for evaluating the suitability of a given substance for a particular application

and its behavior during deformation. Considering glass-ceramic materials as brittle glass-crystal composites the mechanical properties are strongly influenced by the

- (1) particle size and volume fraction of crystalline phase
- (2) interfacial bond strength
- (3) differences in elastic modules
- (4) differences in thermal expansion.

### 2.6 Strength and Elasticity

The elastic properties of glass-ceramic materials include the Young's modulus,  $E$ , the modulus of rigidity,  $G$ , the bulk modulus,  $K$ , and the Poisson constant,  $\mu$

The following relationship holds among these characteristics:

$$G = \frac{E}{2(1 + \mu)} \quad (2.1)$$

$$K = \frac{E}{3(1 - 2\mu)} \quad (2.2)$$

$$\mu = \frac{E}{2G} - 1 \quad (2.3)$$

The bending strength and the Young's modulus of elasticity of glass-ceramic materials and some other materials are listed in Table 2.4 and Table 2.5.

Table 2.4 Bending Strength [ 11 ]

Material	Bending strength (MPa)
glass	55-70
glass-ceramic materials	70-350
glass-ceramic materials with modified surface	10-1400
electroceramic (glazed)	86-14
ceramics with high $Al_2O_3$ content	212-353
cast iron	140-320 <sup>1)</sup>
steel	300-1400 <sup>1)</sup>

Table 2.5 Young's Modules [ 11 ]

Material	Young's modulus (MPa · 10 <sup>-2</sup> )	Material	Young's modulus (MPa · 10 <sup>-2</sup> )
glass-ceramic materials	8-14	sintered $Al_2O_3$	37.4
fused quartz	7.4	silicite low-loss ceramics	7.0
sodium-calcium glass	7.0	electroceramic	6.7
bore-silicate glass (Pyrex)	6.6	sintered MgO	21.0
ceramics with high $Al_2O_3$ content	28-35	marble	2.7-8.2
		granite	4.2-6.0

As mentioned above, glass-ceramic substances have greater bending strengths and greater module of elasticity than the initial glass and ceramics, although the latter is lower than that for ceramics composed of pure oxides. The change in the bending strength of glass-ceramic substances can demonstrate on the various glass-ceramic systems (Tab. 2.6).

It is apparent from the table 2.6 that the glass-ceramic substance containing MgO has greater strength because of the presence of cordierite  $2MgO \cdot 2Al_2O_3 \cdot 5SiO_2$  as the main crystalline phase and small mismatch in thermal expansion coefficient between the

crystalline and the glass phase. Glass-ceramic substances containing  $\text{Li}_2\text{O}$  having a low coefficient of thermal expansion are usually weaker. The stress between the phases in glass-ceramic materials containing a crystalline phase with a negative or a very low coefficient of thermal expansion is unfavorably distributed, leading to decreased strength. One reason for this effect may also be anisotropy in the thermal expansion of the crystal phases.

**Table 2.6** Bending Strength of Various Types of Glass-Ceramic Material [11]

Glass-ceramic system (nucleating agent)	Main crystalline phase	Bending strength (MPa)
$\text{SiO}_2$ - $\text{Li}_2\text{O}$ (photonucleation Ag, Cu, Au)	$\text{Li}_2\text{O} \cdot \text{SiO}_2$ - $\text{Li}_2\text{O} \cdot 2\text{SiO}_2$	80-150
$\text{SiO}_2$ - $\text{Al}_2\text{O}_3$ - $\text{Li}_2\text{O}$ ( $\text{TiO}_2$ , $\text{ZrO}_2$ )	$\beta$ -spodumene s.s.	110-150
$\text{SiO}_2$ - $\text{Al}_2\text{O}_3$ - $\text{Li}_2\text{O}$ ( $\text{TiO}_2$ , $\text{ZrO}_2$ )	$\beta$ -quartz s.s.	60-110
$\text{SiO}_2$ - $\text{Al}_2\text{O}_3$ - $\text{MgO}$ ( $\text{TiO}_2$ )	cordierite	150-300
$\text{SiO}_2$ - $\text{Al}_2\text{O}_3$ - $\text{CaO}$ (fluorides, sulphide)	wollastonite anorthite	70-130
$\text{SiO}_2$ - $\text{Al}_2\text{O}_3$ - $\text{ZnO}$ ( $\text{TiO}_2$ )	gahnite	70-130
$\text{SiO}_2$ - $\text{Al}_2\text{O}_3$ - $\text{ZnO}$ ( $\text{ZrO}_2$ , $\text{SnO}_2$ )	$\beta$ -quartz s.s.	60-110
$\text{SiO}_2$ - $\text{Al}_2\text{O}_3$ - $\text{MgO}$ - $\text{K}_2\text{O}$ - $\text{F}$ (interface between the two liquid phases)	fluorophlogopite	80-105

The elasticity modulus of glass is, to a certain degree, an additive function of the chemical composition. It is assumed that this function for glass-ceramic materials is dependent on the elasticity modulus of the main crystalline phase, although it is also affected by oxides contained in the glass phase, primarily  $\text{CaO}$ ,  $\text{MgO}$  and  $\text{Al}_2\text{O}_3$ .

In this study, we choose the IBM system-3080 and IBM system-3081 [ 10 ] as our basic modules for analysis. these modules, as shown in Fig. 2.9, are used in the construction of high-performance computers [ 10 ].

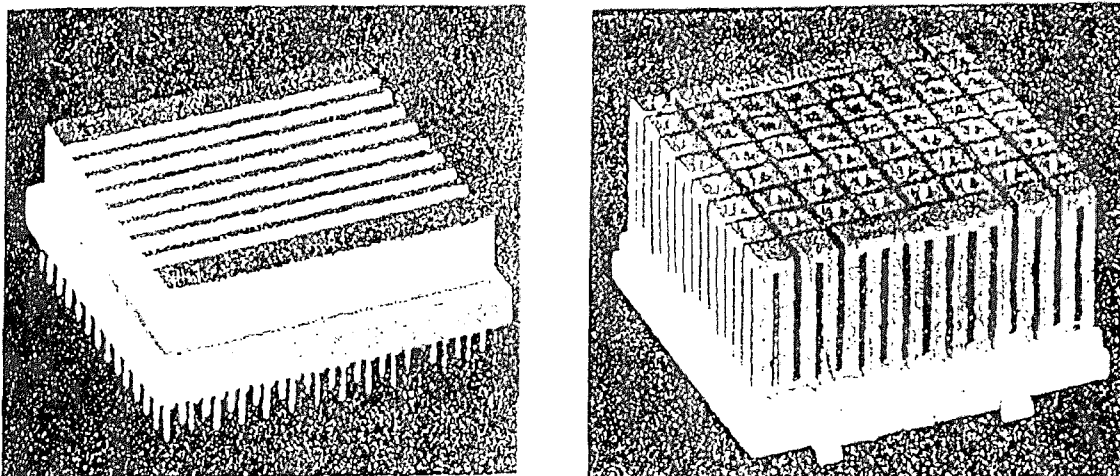

Figure 2.9 System 3081 and System-3080

The laminate materials of these systems are high alumina ceramic (Table 2.7 ) and molybdenum manganese metallization. Construction details are shown in Fig 2.10.

Table 2.7 Composition of Laminate

CaO	7.10 wt%
MgO	8.85 wt%
SiO <sub>2</sub>	54.90 wt%
Al <sub>2</sub> O <sub>3</sub>	29.00 wt%

The body is made of 89% A-14

In IBM System-3081, its multilayer ceramic structure contains eleven layers. Each layer is a 150 mm square by 0.3 mm thick laminate. In IBM System-3080, its multilayer ceramic structure contains 33 layers structure, each layer is a 90 mm square by 0.3 mm laminated MLC.

The green sheets use SiO<sub>2</sub>-Al<sub>2</sub>O<sub>3</sub>-CaO system ceramic, which is called as Alcoa A-14. A-14 is a glass-ceramic substance based on blast-furnace slag. It has good mechanical

strength, high abrasion resistance, good chemical resistance in acid medium. Its physics-mechanical property is in Table 2.8.

Table 2.8 Green Sheet ( Unfired ) Properties

Property	Unit	A-14
Density	$\text{kgm}^{-3}$	3100
Softening point	$^{\circ}\text{C}$	950-1000
Bending strength	MPa	78.5-117.5
Compressive strength	MPa	490-588
Tensile strength	MPa	24.5-34.5
Young's modulus	$\text{Kg/M}^2$	1.1 E+9
Poisson constant		0.21-0.28

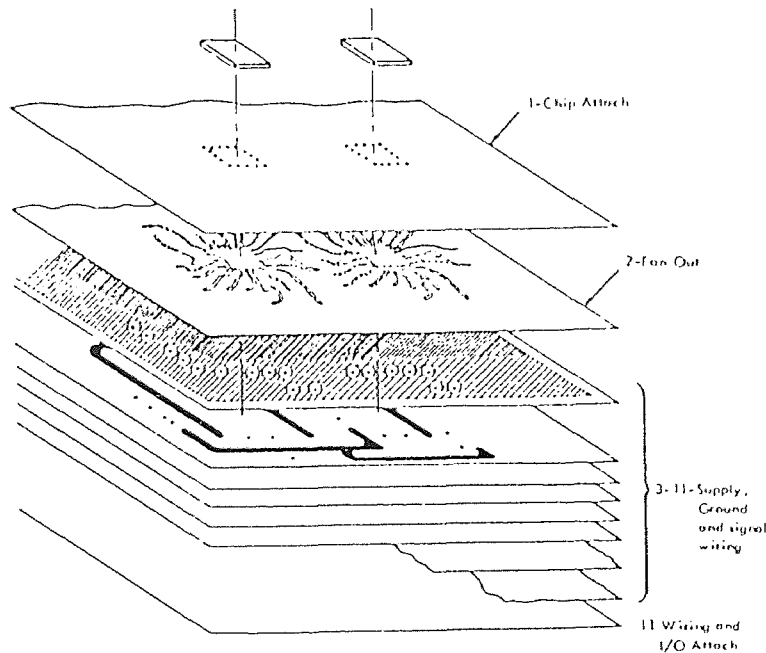
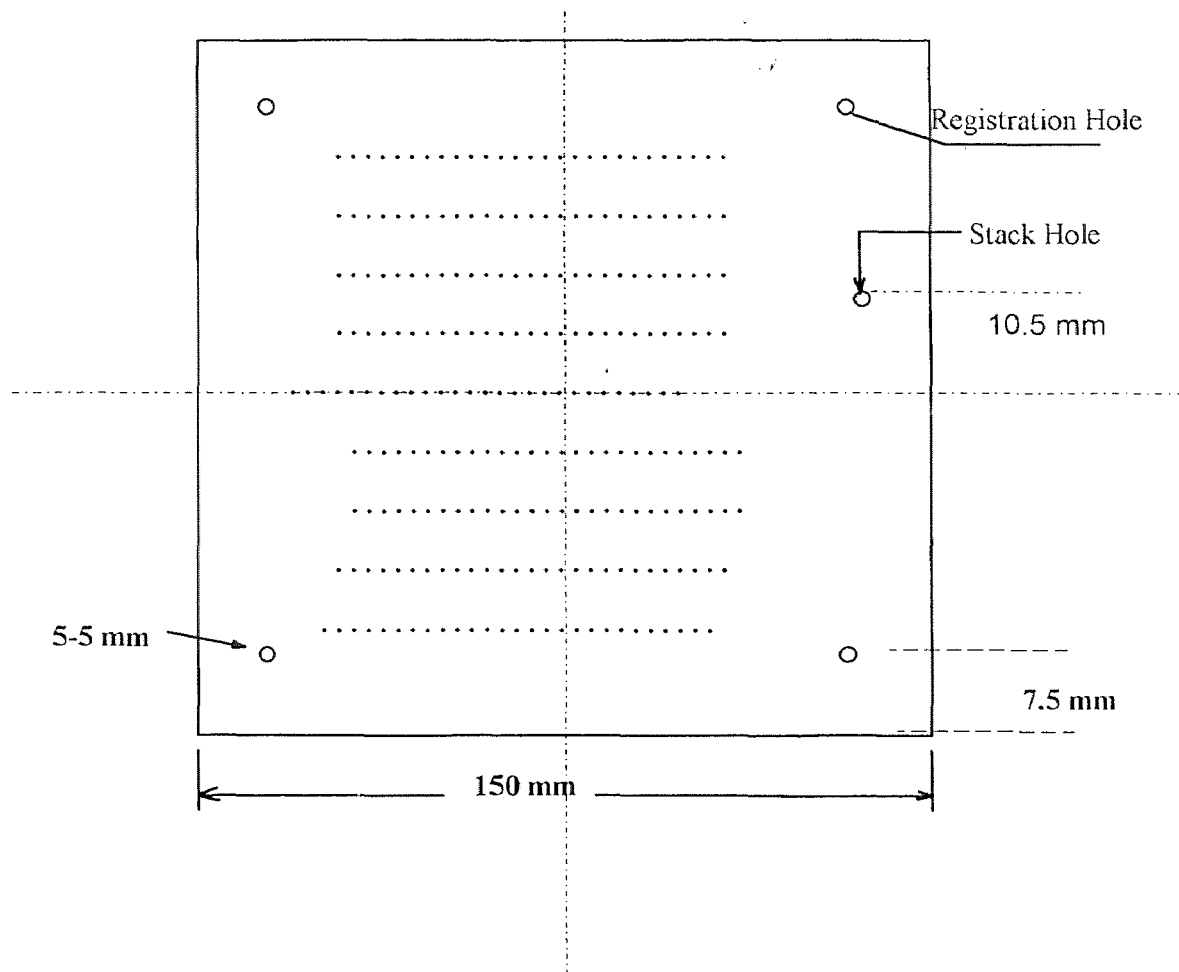

Figure 2.10 Module Structure

The laminate of IBM System-3081 and System-3080 is shown schematically in Fig 2.11, A key element of the assembly is a multiplier ceramic substratum capable of

providing power distribution and wiring for up to 100 logic chips ( with up to 704 circuits per chip ) or a combination of 118 logic or array chips. We always punched four registration holes in all four corners. The holes are used for location in subsequent steps. It is also necessary punched a stacking hole. This is used later in the substrata stacking operation.



**Figure 2.11** Dimensional Requirements on Via Punch Blank [ 5 ]



## CHAPTER 3

### ANALYSIS STRESS AND DISPLACEMENT OF THE GREEN SHEET

The stress and displacement generated the handling of the laminated MLC green sheets provide useful information for designing handling tools. Large stress may cause damage to the laminated MLC green sheets, and large displacement may get problem for assembly. It becomes necessary to discuss the reduced stress and displacement of green sheets when they are handled by the pick-up tools..

We assume the green sheets are handled by either a two-holder or a four-holder pick-up tool. the holders of the pick-up tool are set at the corners, near the registration holes (Fig. 3.1 ). In this thesis, the finite element module in I-DEAS is chosen to analyze the stress and displacement of laminated green sheets.

#### **3.1 The General Structure of Finite Element Module in I-DEAS**

Since the green sheets are rectangular in shapes, we used two-dimensional bilinear quadrilateral elements for constructing meshes. This type of elements is the simplest of the family of finite element methods. In normal practice, the determination of the performance of a device during its design process is accomplished by analysis of the partial differential equations. This involves the following three steps ( Fig 3.2 ):

- ( 1 ) the description of the geometry, the physical characteristics and the mesh
- ( 2 ) the application of the FEM.
- ( 3 ) the visualization and interpretation of the results of the simulation

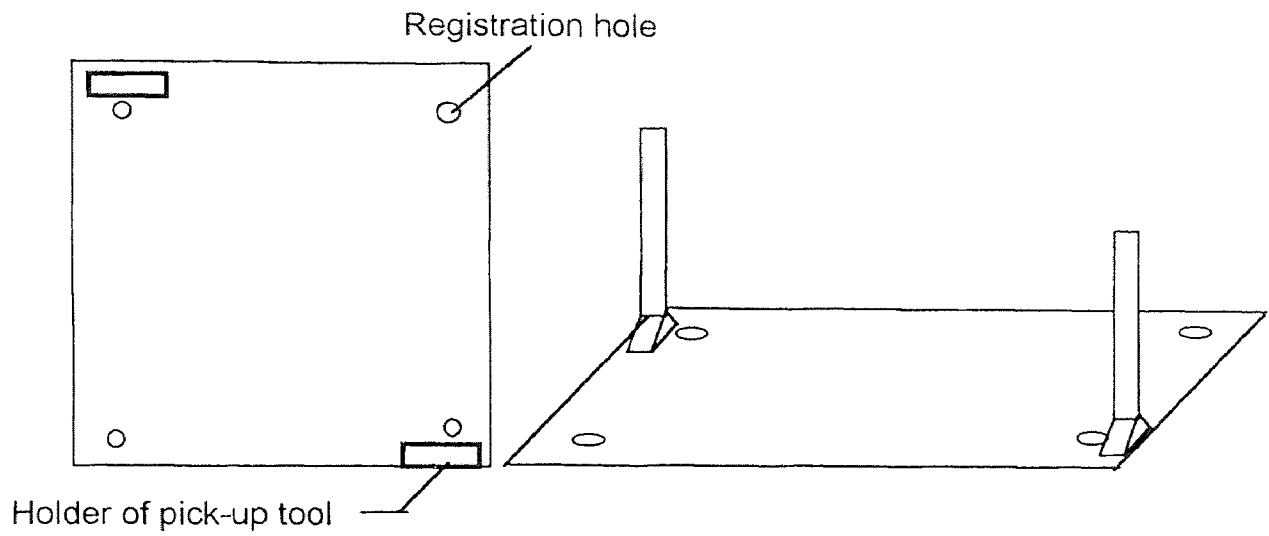

( a ) Two-holder pick-up tool

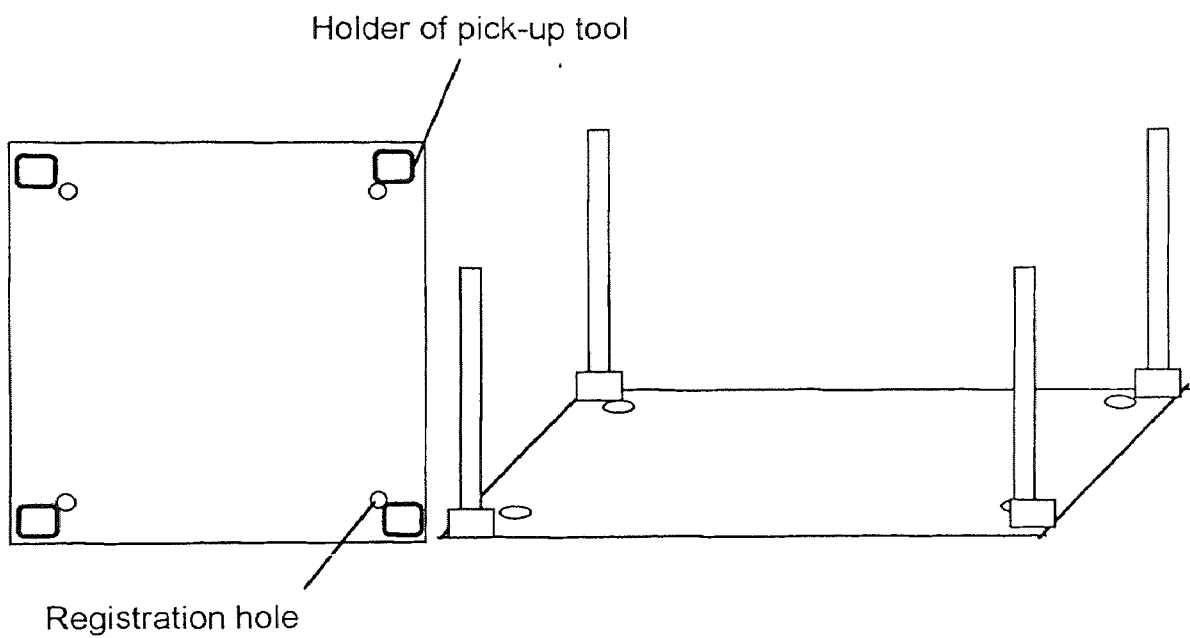

( b ) Four- holder pick-up tool

**Figure 3.1** Pick-Up Tools

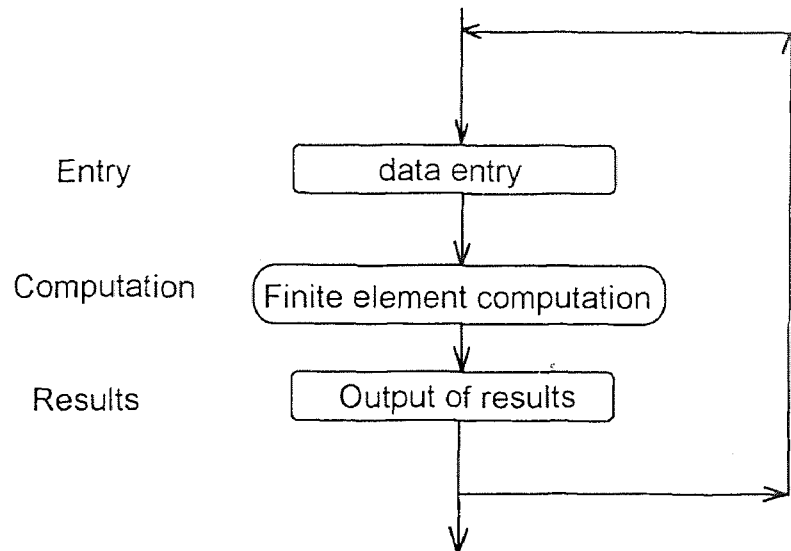

**Figure 3.2** Flow Chart of The Operation of A Finite Element Program

These three steps are quite distinct and correspond to creating, on the programming level, the three distinct modules:

- ( 1 ) the module to enter the data
- ( 2 ) the module to perform the analysis
- ( 3 ) the module to analysis

### **3.2 Data Entry Module in I-DEAS**

The data enter module is used for entering all the information necessary for the analysis of the problem by the FEM. This data relates to the discretization of the domain and the representation of its physical behavior. In this chapter, we used two kinds of multilayer ceramic green sheets, IBM System-3081 and IBM System-3080.

### 3.2.1 Size of laminate

The size of IBM System-3081 is 150 mm and 150 mm by 0.3 mm green sheet.

The size of IBM System-3080 is 90 mm and 90 mm by 0.3 mm green sheet.

### 3.2.2 Size of element

In this chapter, we decided to choose four different kinds of mesh ( $N= 5, 10, 15, 20$ ) to analysis the laminate. Since the size of green sheet is small, it is difficult to choose too many elements in the FEM.

#### A. Mesh one

$N=5$ , the number of element is 25, the number of nodes is 36, the length of element is 0.03 mm quadrilateral element of system-3081.

#### B. Mesh two

$N=10$ , the number of element is 100, the number of nodes is 121, the length of element is 0.015 mm quadrilateral element of system-3081.

#### C. Mesh three

$N=15$ , the number of element is 225, the number of nodes is 256, the length of element is 0.01 mm quadrilateral element of system-3081.

#### D. Mesh four

$N=20$ , the number of element is 400, the number of nodes is 441, the length of element is 0.0075 mm quadrilateral element. ( Fig. 3.3 )

We mainly explain mesh two in this chapter, because the data entry of other three meshes is essentially the same as mesh two.

The element of IBM System-3081 is 15 mm by 15 mm bilinear element.

The element of IBM System-3080 is 9 mm by 9 mm bilinear element.

We can get total 100 elements and 121 nodes in each laminate. ( Fig 3.4 )

In this thesis, the material properties are assumed to be independent of temperature.

### 3.3 Material Properties Set

#### 3.3.1 Density

The density of the green sheet is  $3100 \text{ kg/m}^3$  ( Table 2.9 ).

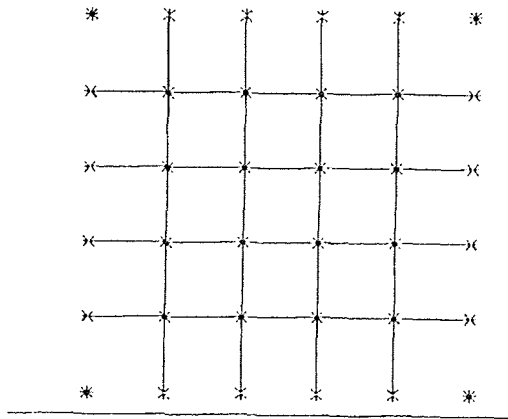

Mesh one

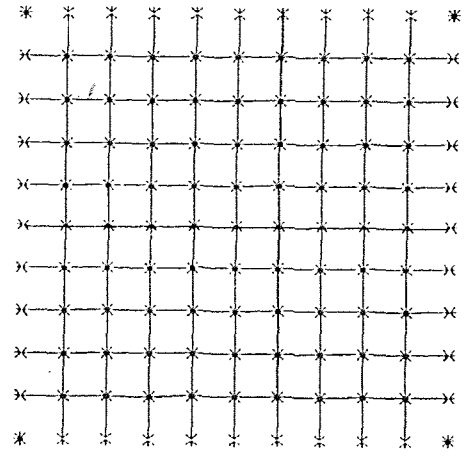

Mesh two

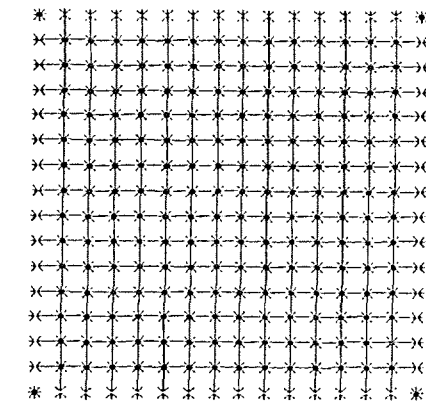

Mesh three

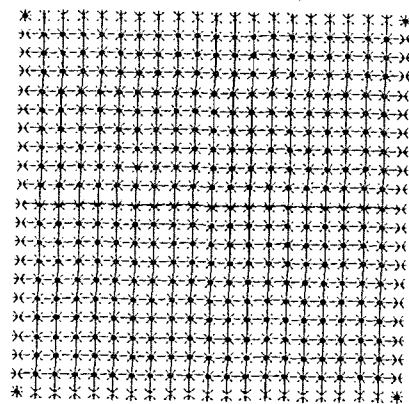

Mesh four

Figure 3.3 Difference Meshes

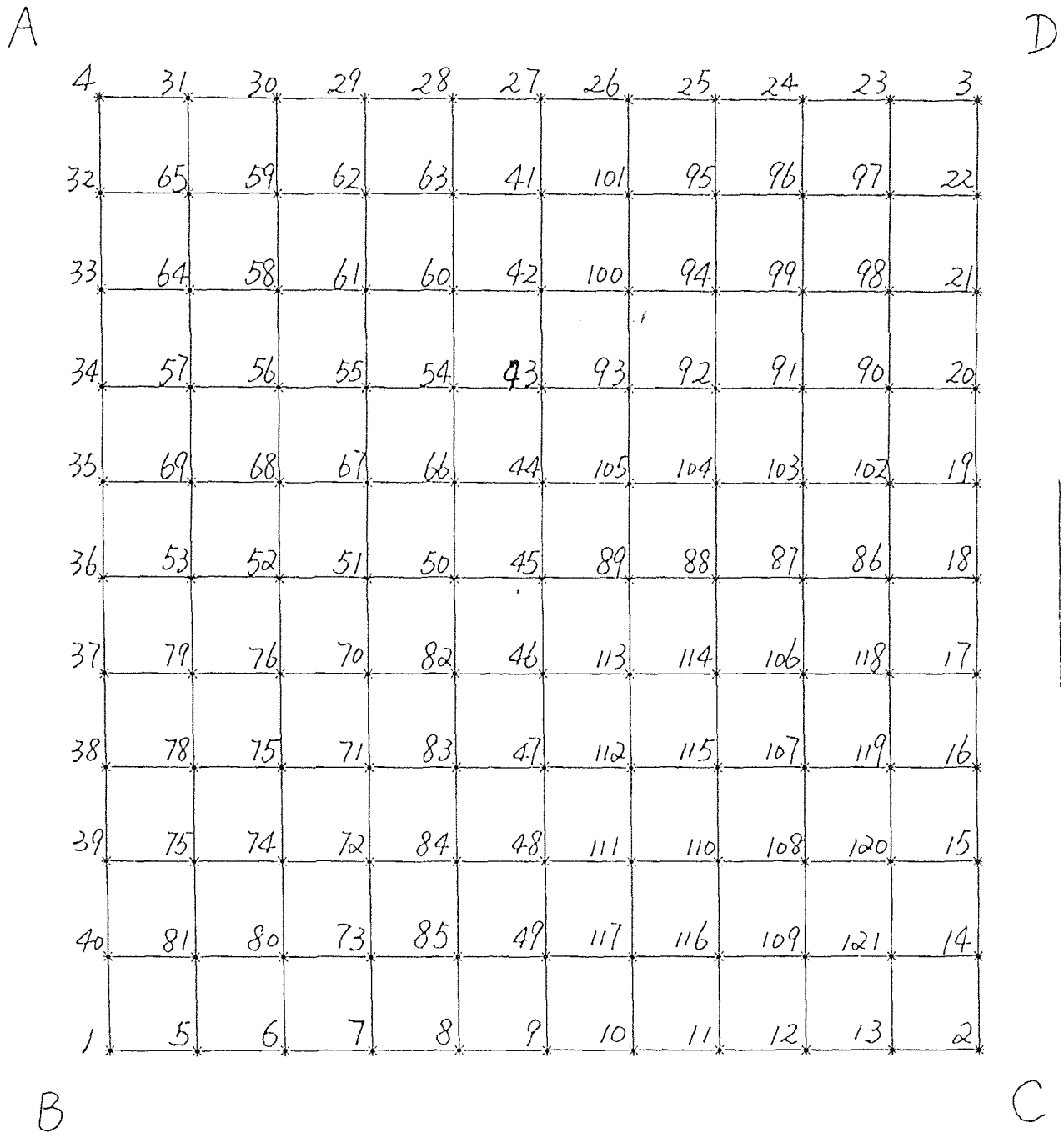

Figure 3.4 Two-Dimensional Mesh ( Quadrilateral Element )

### 3.3.2 Weight of laminate

Weight of laminate for the entire sheet is volume times density of laminate.

a) IBM System-3081

$$150 \times 150 \times 0.3 \times 3.1 \text{E-}3 = 20.925 \text{g}$$

b) IBM System-3080

$$90 \times 90 \times 0.3 \times 3.1 \text{E-}3 = 7.53 \text{ g}$$

### 3.3.3 Node force

In this chapter, we assume that the load is due to weight of the green sheet in every element ( Fig 3.4 ), the weight of the element is distributed on each node of the element, we define the weight on each node as node force and got:

a) IBM System-3081

The weight of each element:

$$20.925 \text{ g} \div 100 = 2.09 \text{E-}4 \text{ kg}$$

Node force at the four corner nodes ( Node 1, 2, 3, 4, )

$$20.925 \text{ g} \div 4 = 5.225 \text{E-}5 \text{ kg}$$

Node force at the boundary nodes ( Node 5, 6, 7, 8, 9, 10, 11, 12, 13, 14, 15, 16, 17, 18, 19, 20, 21, 22, 23, 24, 25, 26, 27, 28, 29, 30, 31, 32, 33, 34, 35, 36, 37, 38, 39, 40)

$$20.925 \text{ g} \div 2 = 1.045 \text{E-}4 \text{ kg}$$

Node force at the other nodes ( node 41 to 121 ) is  $2.09 \text{E-}4 \text{ kg}$

we call this set of node force as LOAD 1

b) IBM System-3080

Weight of each element:

$$7.53 \text{ g} \div 100 = 7.53 \text{E-}5 \text{ kg}$$

Node force at the four corner nodes ( Node 1, 2, 3, 4, )

$$7.53 \text{E-}5 \text{ kg} \div 4 = 1.8825 \text{E-}5 \text{ kg}$$

Node force at the boundary nodes ( Node 5, 6, 7, 8, 9, 10, 11, 12, 13, 14, 15, 16, 17, 18, 19, 20, 21, 22, 23, 24, 25, 26, 27, 28, 29, 30, 31, 32, 33, 34, 35, 36, 37, 38, 39, 40)

$$( 7.53 \text{E-}5 ) / 2 = 3.75 \text{E-}5 \text{ kg}$$

Node force at the other nodes is  $7.53E-5$  kg

we call this set of node force as LOAD 2

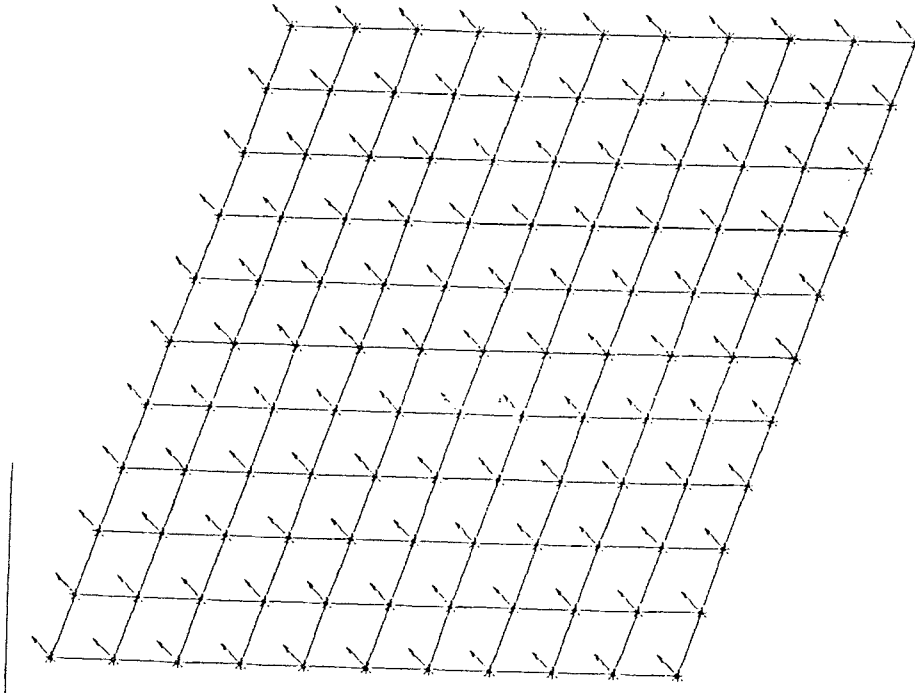

Figure 3.5 Node Force of Green Sheet

### 3.3.4 Modulus Of Elasticity

The modulus of elasticity of green sheet is governed by the nature of the organic resin used as the binder, by the level of ceramic loading. For our discussion, a value of  $1.078E+4$  MPa.( Table 2.8 ) is used.

### 3.4 Boundary Definition

We need to set the boundary condition in order to perform the calculation. In this section, we consider the green sheets are handled by holding their four corners. We set the 3-D



coordinate at corner B and use the unformed green sheet as X-Y work plane. No boundary conditions are set on the edges, since they are not constrained and free to consider that no displacement at the four corner nodes ( node 1, 2, 3, 4 ) which are hold by the pick-up tool.

### 3.5 Case Set

After defining the laminate and Restrain sets, we can now study the displacement and stress of green sheet. Two different system and load combinations are considered in the computation of stress and displacement. They are represented by the following four cases:

1) Case one

We defined displacement of System-3081 at Load One and Restrain

2) Case two

We defined stress of System-3081 at Load One and Restrain

3) Case three

We defined stress of System-3080 at Load Two and Restrain

4) Case four

We defined displacement of System-3080 at Load Two and Restrain .

### 3.6 Solution and Post Processing

The I-DEAS FE modeling & Analysis can solves the linear or non-linear system of equations coming from the variational or the projective formulation. In our case, its input is the domain discretization, the physical characteristics and the boundary conditions. The postprocessor is the most important in I-DEAS Finite Element Modeling and Analysis. It can provide a certain number of numeric results apart from the main finite element solution. After postprocessing, we can obtain both graphic result and the data. Its output is value of the displacement and stress at each the nodes of the grid. From the data of displacement, we can got the displacement in X, Y, Z- directions at each node ( Disp-X,

Disp-Y, Disp-Z ), and Rotations ( Rot-X, Rot-Y, Rot-Z ). From data of stress, we can get the principal stress and shearing stress at each node.

### 3.6.1 Analysis of System-3081

The system was set in case one and case two.

#### A) Case one

The green sheet is handled by four-holder pick-up tool in this case. We set the four holders at each corner. The displacement of green sheet is calculated by I-DEAS, and the data is reported in the Fig 3.6 and Appendix Table 1. The color code used in Fig. 3.6 is as follow:

<b>COLOR</b>	<b>DISPLACEMENT ( mm )</b>
RED	1.882 TO 2.196
ORIGIN	1.225 TO 1.882
YELLOW	0.941 TO 1.255
GREEN	0.625 TO 0.941
BLUE	0.314 TO 0.625
DARK BLUE	0.000 TO 0.314

From the Appendix table one, we can obtain displacement at each node of X-Y-Z directions ( Disp-X, Disp-Y, Disp-Z ) and three rotations ( Rot-X, Rot-Y, Rot-Z ) about 3-axis. In Fig. 3.6, we got the maximum displacement is 2.2 mm at center of green sheet (Node 45 ).

#### B ) Case two

This case discuss the principal stress and shear stress when we use the four-holder pick-up tool to handle the green sheet. the result is given from I-DEAS in the Fig. 3.7 and the Appendix Table 2

The color code used in Fig. 3.7 is as follow:

COLOR	THE PRINCIPAL STRESS (kg/m <sup>2</sup> )		
RED	8.724E+4	TO	1.28E+5
ORIGIN	5.272E+3	TO	8.724E+4
YELLOW	-3.573E+4	TO	5.272E+3
GREEN	-7.673E+4	TO	-3.573E+4
BLUE	-1.18E+5	TO	-1.59E+5

From the data in appendix table 2, we can obtain the principal stress and shearing stress at each node. The maximum stress is 1.28E+5 ( Node 45 ) in center area, and the minimum stress is -1.18E+5 at four corners A, B and C, D ( node 1, 2, 3, 4, ). In the center area, the principal stress is 5.272E+3 kg/m<sup>2</sup> to 1.28E+5 kg/m<sup>2</sup>. The minimum principal stress and the maximum shearing stress are close to the four corners.

### 3.6.2 Analysis system-3080

#### A) Case three

The green sheet of system-3080 is handled by four holders in this case, we set the four holders at each corner, and get the solution from I-DEAS, the data is reported in the Fig. 3.8 and Appendix Table 3. The color code used in Fig. 3.7 is as follow:

COLOR	DISPLACEMENT (UNIT: mm)		
RED	0.243	TO	0.28
ORIGIN	0.162	TO	0.243
YELLOW	0.121	TO	0.162
GREEN	0.0809	TO	0.121
BLUE	0.0405	TO	0.809
DARK BLUE	0.000	TO	0.0405

In this case, the maximum displacement of green sheet is 0.3 mm at center( Node 45), this is better result we want. Deflection of center area will be less than 0.28 mm. It is very small, and only 23 % of System-3081. We use the four pick-up holders to handle the small sized green sheet, we find the displacement of green sheet is smaller than large sized B) Case four

In this case, we discuss the principal stress and shear stress of system-3080 which was handled by four-holder pick-up tool, the result can be got from I-DEAS, the data reported is in the Fig. 3.9 and Appendix Table 4,

The color code used in Fig. 3.9 is as follow:

COLOR	PRINCIPAL STRESS (UNIT kg/m <sup>2</sup> )		
RED	3.1277.40	TO	45972.25
ORIGIN	1887.69	TO	3.1277.40
YELLOW	-12807.17	TO	1887.69
GREEN	-27502.02	TO	-12807.17
BLUE	-42198.88	TO	-27502.02
DARK BLUE	-56891.73	TO	-42198.88

We find the stress is very small when we catch the green sheet in this case, it is less 4.6E+4 kg/m<sup>2</sup> in center area, the maximum shearing is close to the holder, it is only 36 % of System-3081.

### 3.7 Comparison of Mesh Size Numbers

We have got the result from mesh two and will compare with the other three meshes.

From the I-DEAS, we can obtain the data in Table 3.1 and Table 3.2.



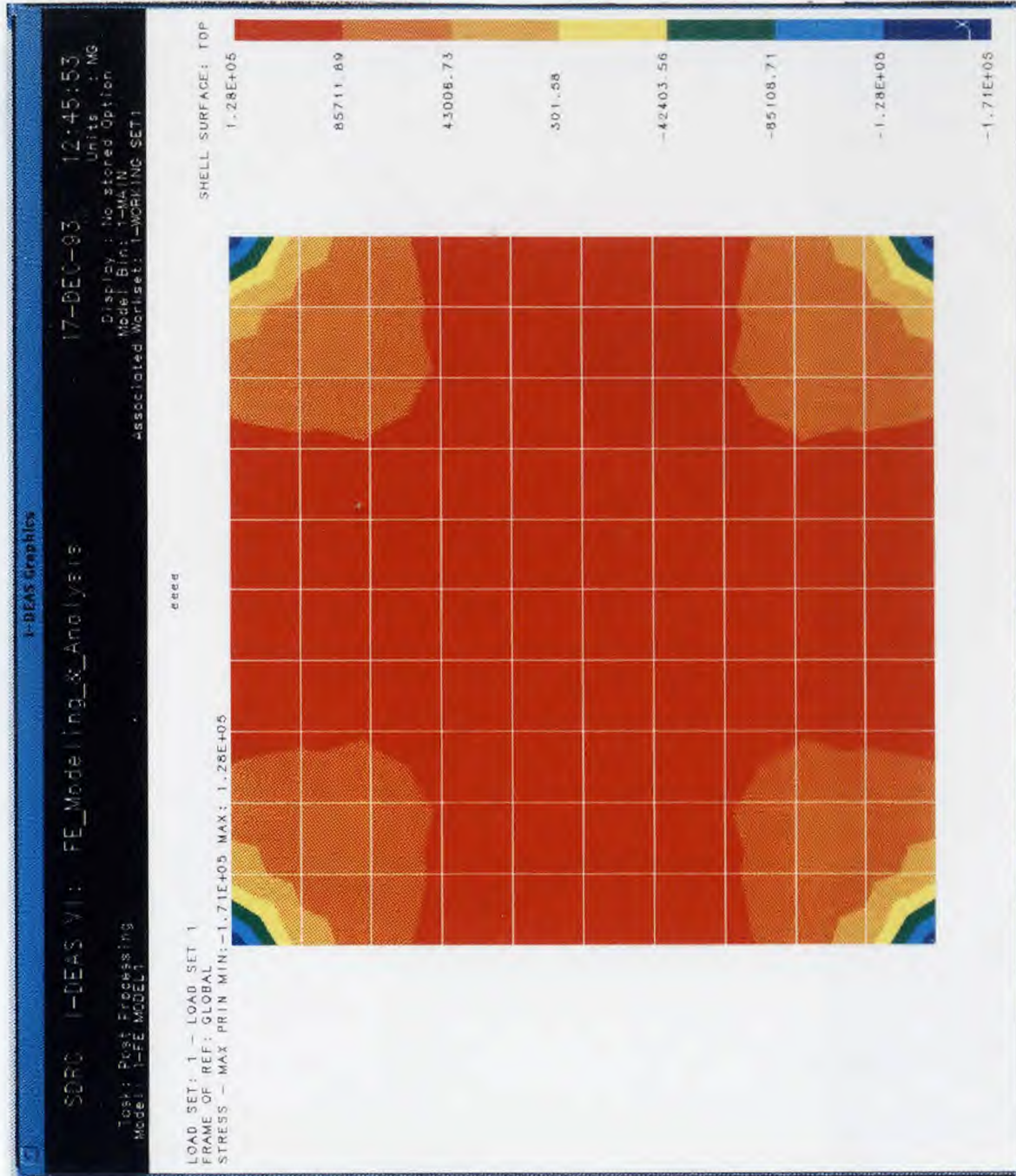

Figure 3.7 Stress Plot of Case 2

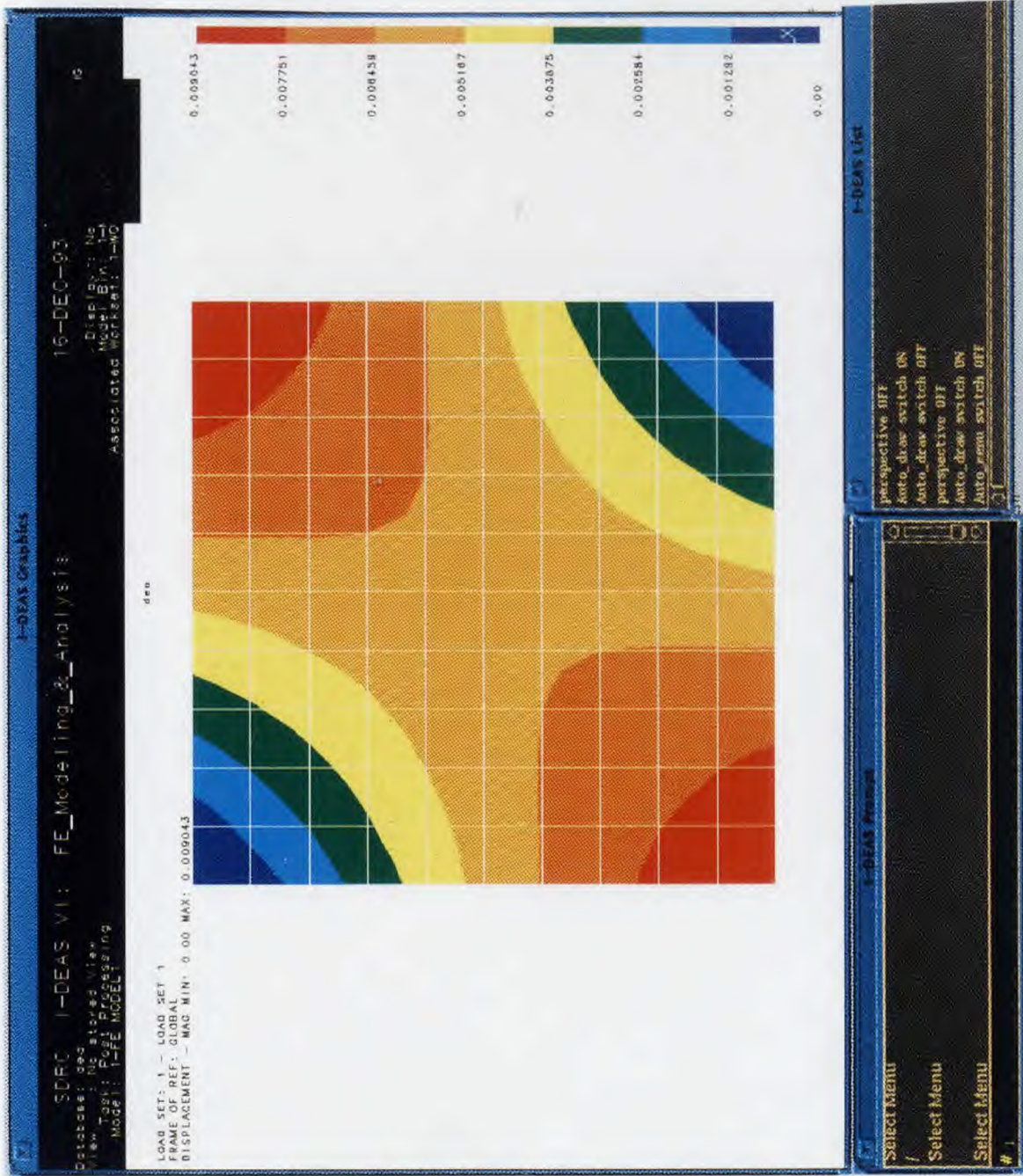

Figure 3.8 Displacement Plot of Case 3.

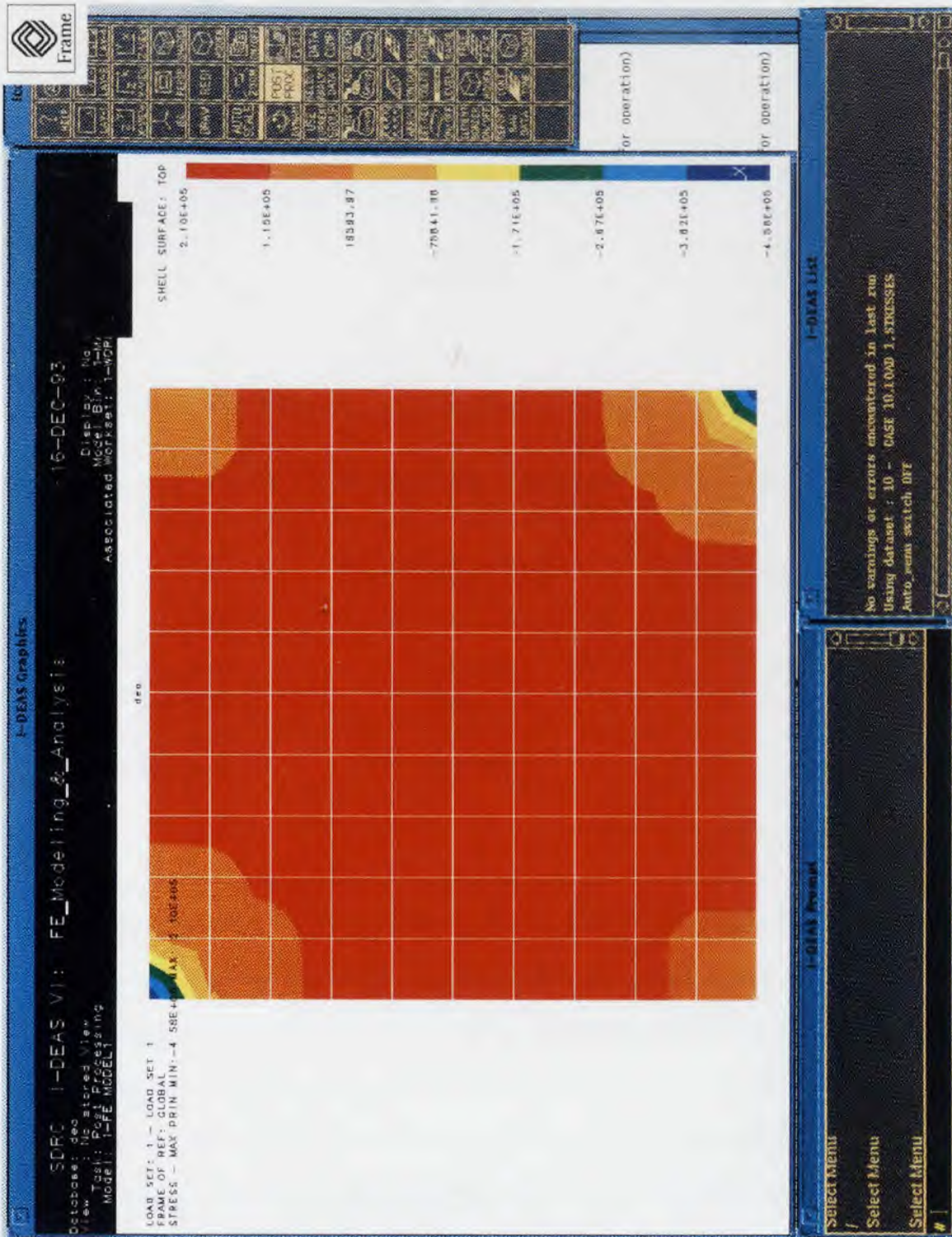

Figure 3.9 Stress Plot of Case 4.



**Table 3.1** Different Data of System 3081 In Different Meshes

	<b>Max. displacement D1</b> m	<b>Max. principal stress <math>\sigma_1</math></b> kg/m <sup>2</sup>
<b>Mesh 1</b>	<b>1.492E-3</b>	<b>1.022E5</b>
<b>Mesh 2</b>	<b>2.196E-3</b>	<b>1.283E5</b>
<b>Mesh 3</b>	<b>2.448E-3</b>	<b>1.371E5</b>
<b>Mesh 4</b>	<b>2.617E-3</b>	<b>1.432E5</b>

**Table 3.2** Different Data of System 3080 In Different Meshes

	<b>Max. displacement D1</b> m	<b>Max. principal stress <math>\sigma_1</math></b> kg/m <sup>2</sup>
<b>Mesh 1</b>	<b>1.94E-4</b>	<b>3.691E4</b>
<b>Mesh 2</b>	<b>2.83E-4</b>	<b>4.597E4</b>
<b>Mesh 3</b>	<b>3.13E-4</b>	<b>4.867E4</b>
<b>Mesh 4</b>	<b>3.38E-4</b>	<b>5.131E4</b>

After comparing the different meshes in table 3.1 and table 3.2, we can see that the more accurate result can be obtained when the green sheets are divided into more elements. For example in system-3081, the change of displacement is 0.704 mm and change of Max. principal stress is 0.261E5 between mesh 1 and mesh 2. The change of displacement is 0.252 mm and change of Max. principal stress is 0.088E5 between mesh 2 and mesh 3. The change of displacement is only 0.106 mm and change of Max. principal stress is only 0.051E5 between mesh 3 and mesh 4. It is almost as same as in system-3080. If better accuracy is desired, the smaller elements should be used.

### 3.8 Compare With Two Holder Pick-Up Tool

#### 3.8.1 Restraint Set

We set the two holders at corner A ( Node 4 ), C ( Node 2 ), and keep this two nodes as no displacement during stacking, we call it as restraint two.

#### 3.8.2 Case Set.

1) Case Five

We defined displacement of System-3081 at LOAD ONE and RESTRAIN Two.

2) Case Six

We defined stress of System-3081 at LOAD ONE and RESTRAIN Two.

3) Case Seven

We defined displacement of System-3080 at LOAD TWO and RESTRAIN Two.

4) Case Eight

We defined stress of System-3080 at LOAD TWO and RESTRAIN Two.

#### 3.8.3 Result

After calculated by I-DEAS, we will get following results.

a) Case five

This case is the displacement for System-3081 with two-holder pick-up tool. After postprocessing in I-DEAS, we can got the continuous tone plot in the Fig. 3. 10 and data report in the Appendix Table 5.

The color code used in Fig. 3.10 is as follow:

<b>COLOR</b>	<b>DISPLACEMENT (Unit: mm )</b>		
RED	7.65	to	8.929
ORIGIN	5.102	to	7.65
YELLOW	3.827	to	5.102
GREEN	2.551	to	3.827
BLUE	1.276	to	2.551
DARK BLUE	0.000	to	1.276

In Fig. 3.10 and Appendix Table 5, we found that maximum displacement is at Corner B (node 1) and Corner D ( node 3). The value is 8.929 mm. It is close to the registration holes and stacking hole, therefore it will inference with the stacking of the green sheet. The displacement at the center is 6.2 mm. It is about 2.8 times as large as that of case one, so a two-holder tool is not a good choice for system-3081.

b) Case six

This case is deal with the principal stress and shear stress of green sheet when it is handled by a two-holder tool. The results are shown in Fig. 3.11 and Appendix Table 6. The color code used in Fig. 3.11 is as follow:

<b>COLOR</b>	<b>PRINCIPAL STRESS (UNIT: kg/m<sup>2</sup>)</b>		
RED	1.20E+5	TO	2.11E+5
ORIGIN	-6.21E+4	TO	1.20E+5
YELLOW	-1.53E+5	TO	-6.21E+4
GREEN	-2.44E+5	TO	-1.53E+5
BLUE	-3.36E+5	TO	-2.44E+5
DARK BLUE	-4.24E+5	TO	-3.36E+5

The maximum principal stress is  $2.11E+5 \text{ kg/m}^2$  at center wire area, it is about 1.56 times as large as case two. The Maximum minimum shearing stress is  $-4.25E+5 \text{ kg/m}^2$  at two holder C ( node 2 ) and A ( node 4 ). This values is about 3.5 times as large as that of case 2.

c ) Case seven

The data of this case is the displacement of System-3080 under two pick-up holders. After postprocess in I-DEAS, we can be given the solution in Fig 3.12 and Appendix Table 7

The color code used in Fig. 3.12 is as follow:

COLOR	DISPLACEMENT (UNIT mm)		
RED	0.988	TO	1.152
ORIGIN	0.658	TO	0.988
YELLOW	0.494	TO	0.658
GREEN	0.329	TO	0.494
BLUE	0.165	TO	0.329
DARK BLUE	0.00	TO	0.165

The maximum displacement is 1.152 mm at corner B ( Node 1 ) and corner C (Node 3). This displacement at center is still lager than that of case 3, it is 0.8 mm.

d ) Case eight

This case is defined to the principal stress and shear stress of green sheet which is handled by two holders. we can got the principal stress and shear stress in the Fig 3.13 and Appendix Table 8 from the I-DEAS

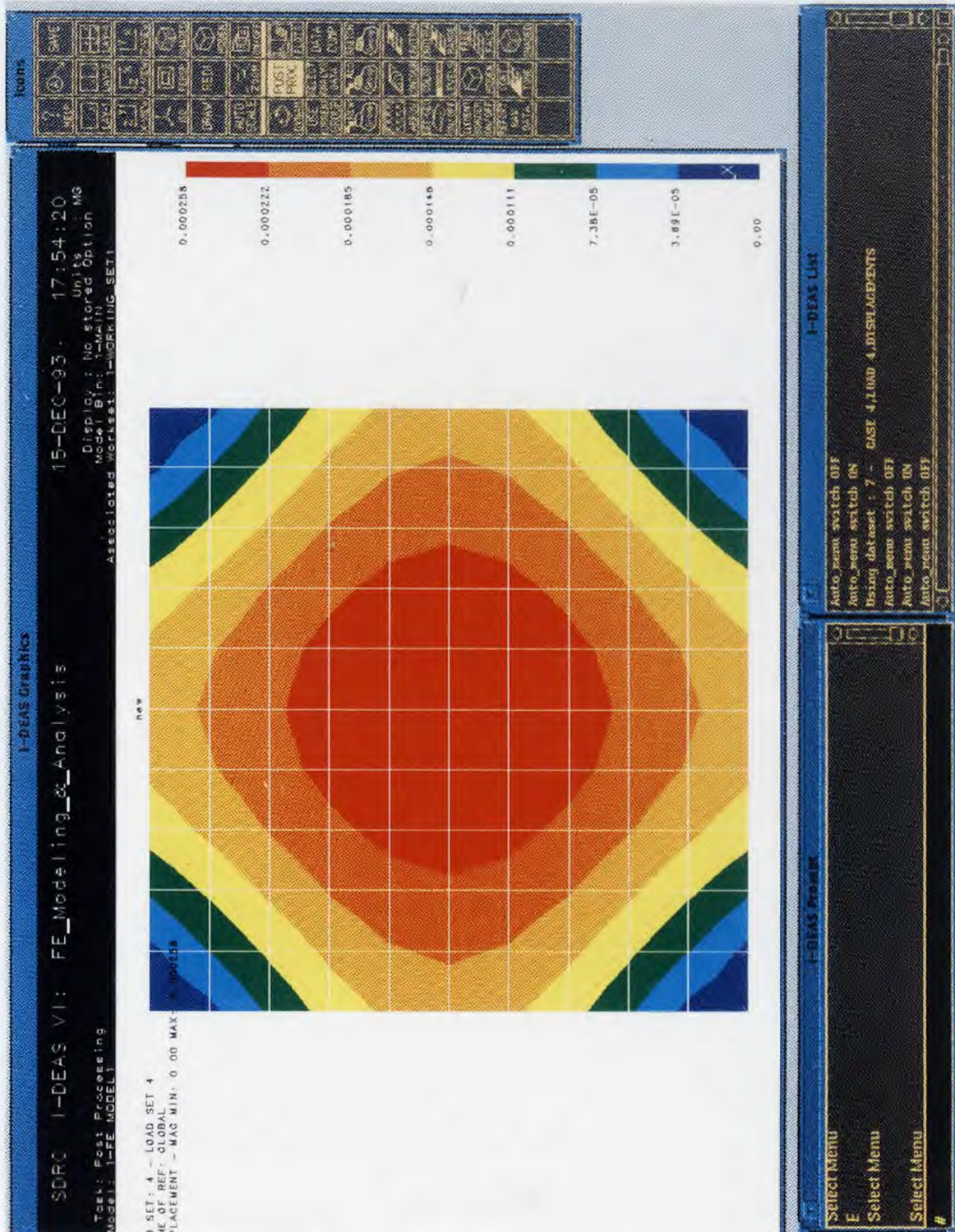

Figure 3.10 Displacement Plot of Case 5

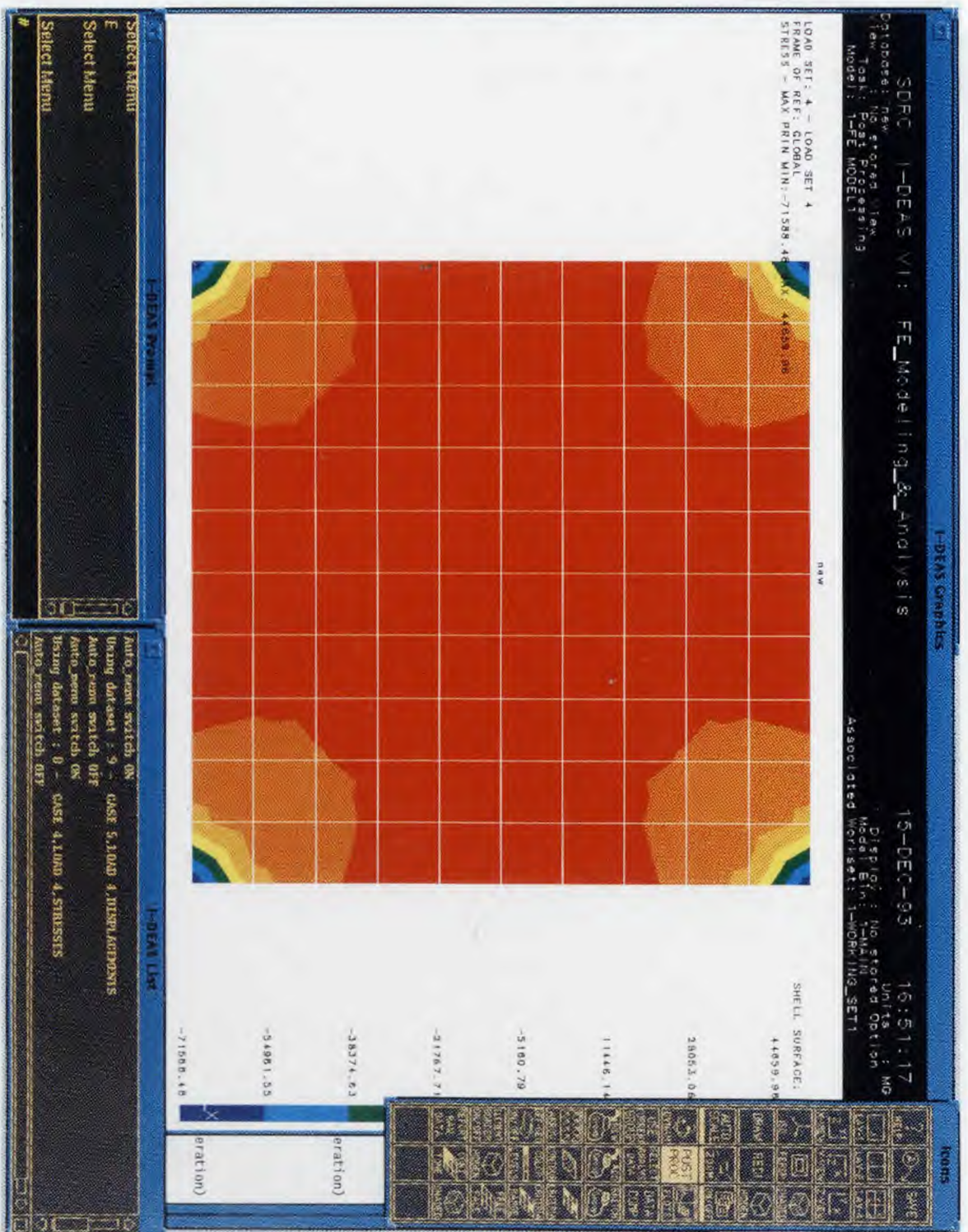

Figure 3.11 Stress Plot of Case 6

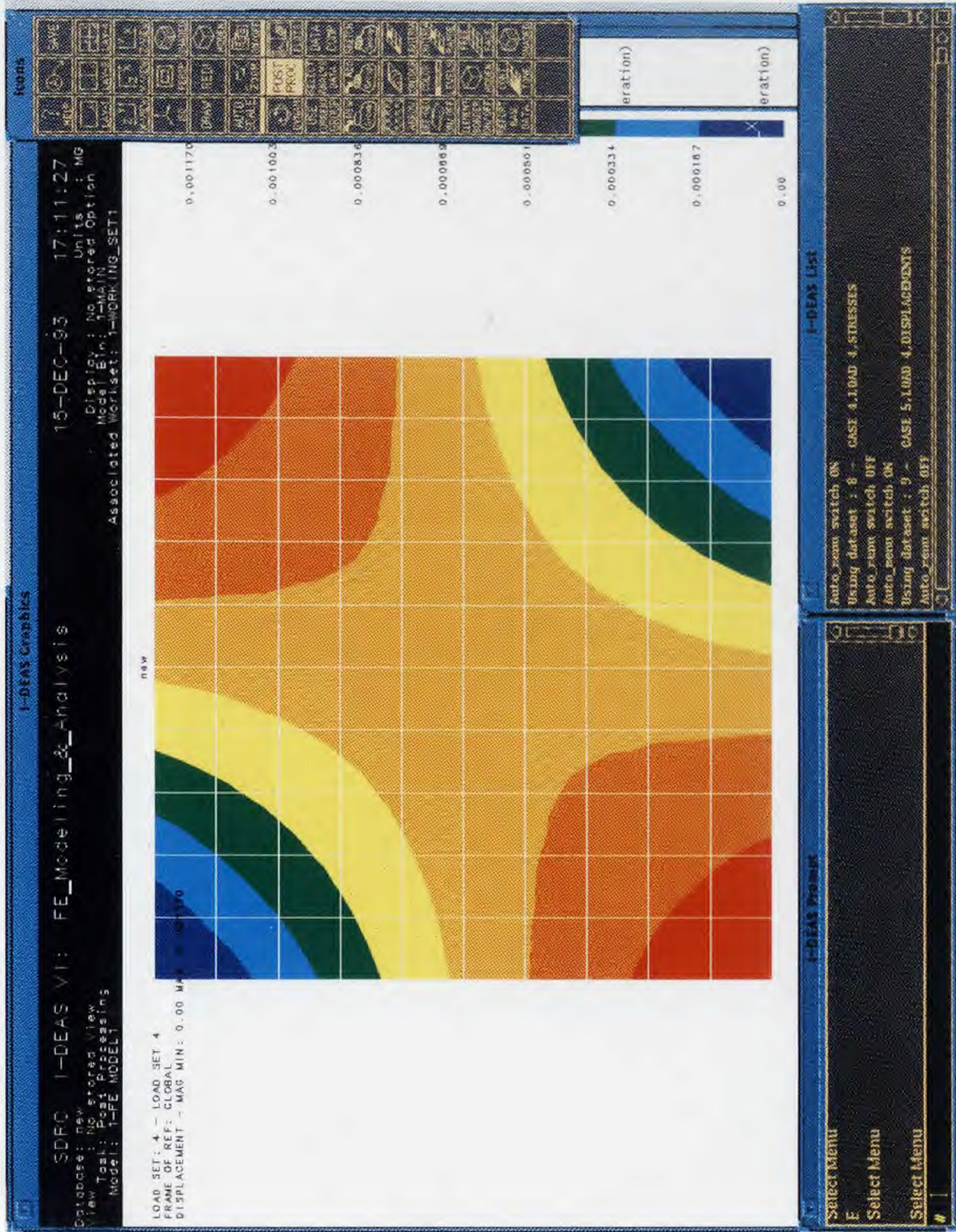

Figure 3.12 Displacement Plot of Case 7

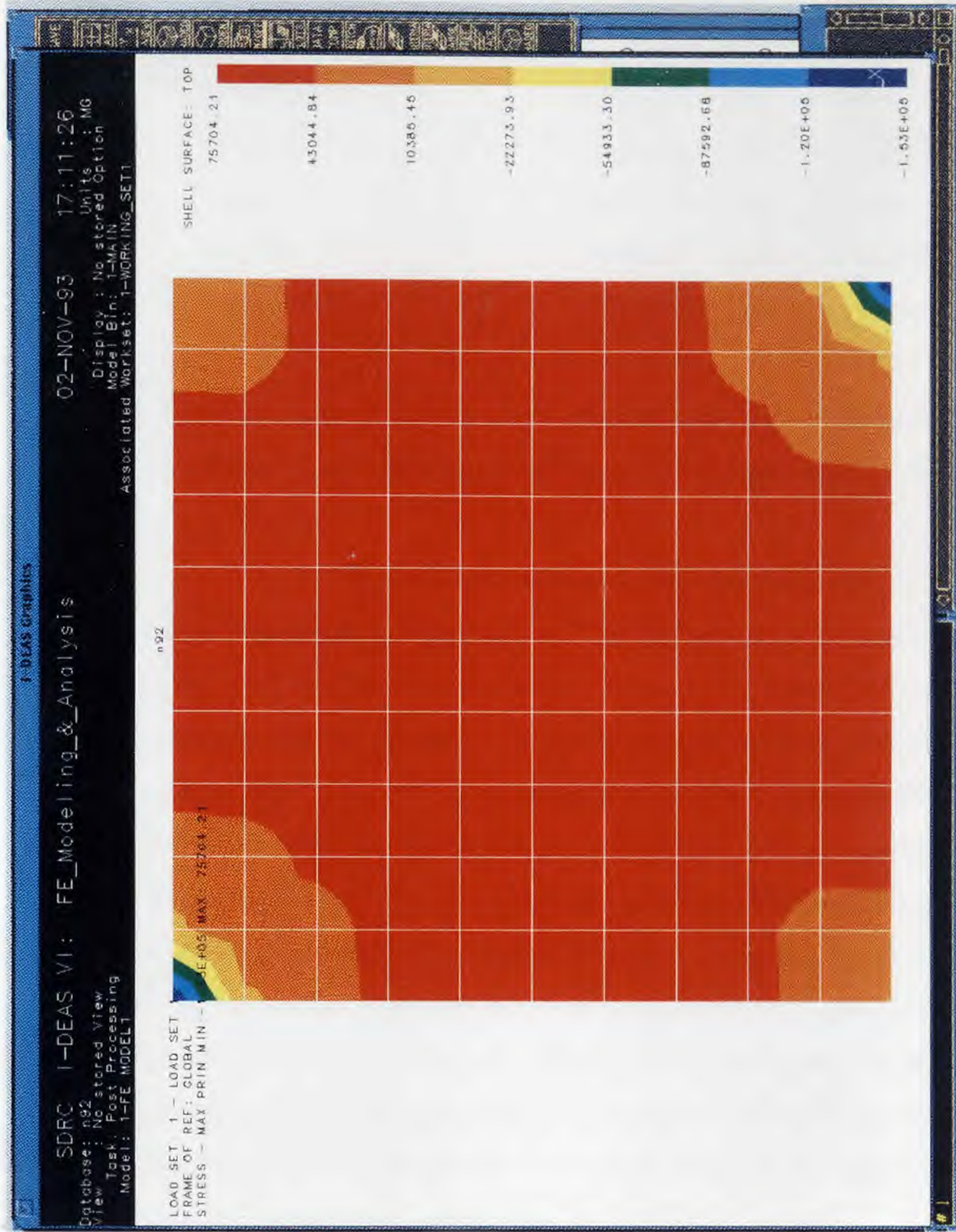

Figure 3.13 Stress Plot of Case 8



COLOR	PRINCIPAL STRESS (UNIT: kg/m <sup>2</sup> )		
RED	43044	TO	75704.21
ORIGIN	-87592.68	TO	43044
YELLOW	-54933.3	TO	-87592.68
GREEN	-87592.68	TO	-54933.3
BLUE	-1.20E+5	TO	-87592.68
DARK BLUE	-1.53E+5	TO	-1.20E+5

The maximum principal stress is more uniform in center area of the green sheet. The largest principal stress occurs at node 4 and node 2, the absolute value is 1.53E+5kg/m<sup>2</sup>.

### 3.9 Comparison of Setting Position in System-3081

There are about 10 mm to 15 mm width between edge and center wire area in green sheet, the position of holder can be set in this area. We assume that the node 65, 81,121 and 91 is between the area, we can adjust the size of the pick-up holders and set holders on these four nodes ( Fig. 3.13 ), and is given the plot of stress ( Fig. 3.14 )and displacement ( Fig. 3.15 ) of system-3081 from the finite element module in I-DEAS. we compare these dates with Case 1 and Case 2. We can got that the maximum displacement of system-3081 in new setting position is 0.5 mm at center of green sheet ( node 45 ), it is about 1/4 of case one. The Maximum principal stress of system-3081 center area in practice is 4.8555E+4 kg/m<sup>2</sup>. it is about 1/2 of case two. It seem more perfect of the design. we still be able to change the position of the pick-up holders and compare by computer, so that we can get the best setting point in each green sheet and set the pick-up holders on these positions to get the best result in stacking and handling.

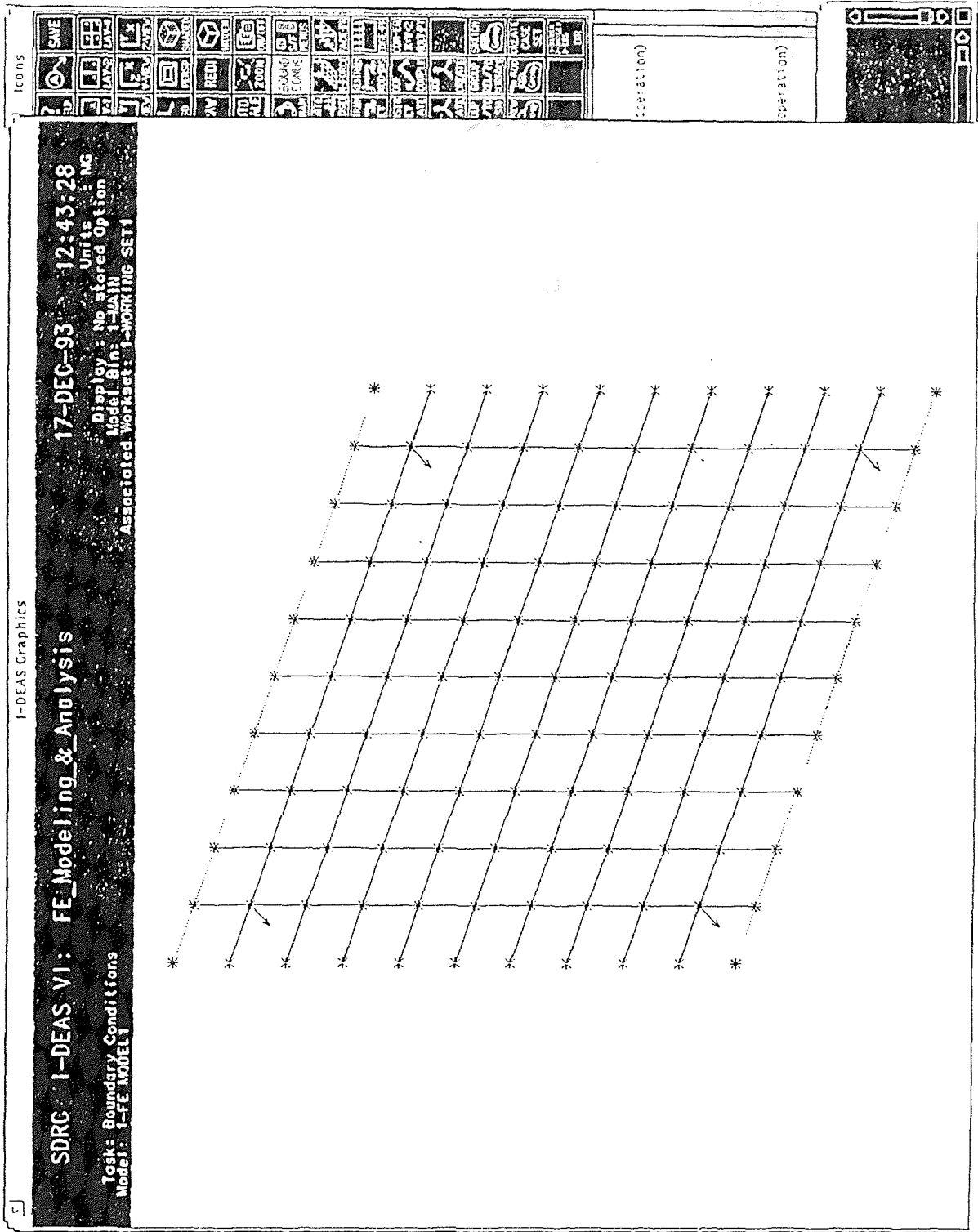
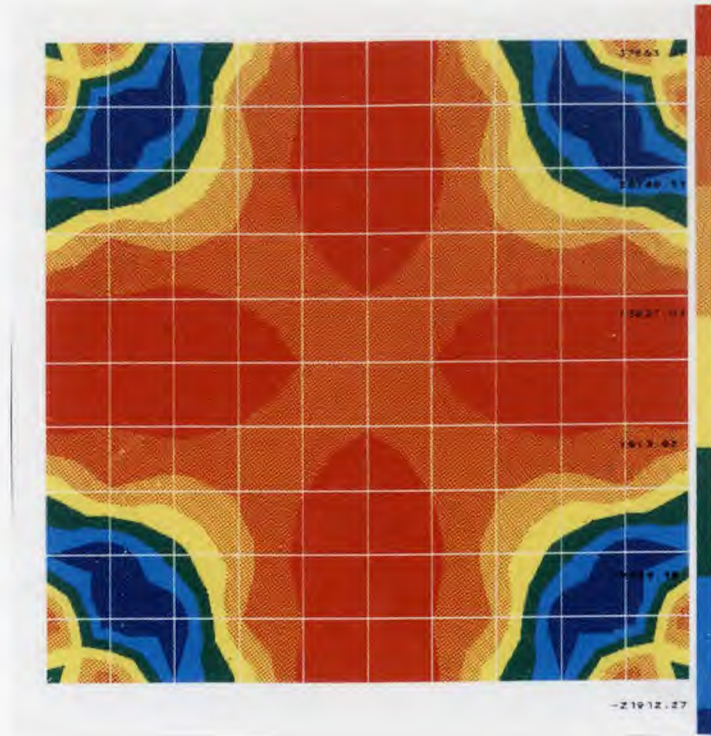
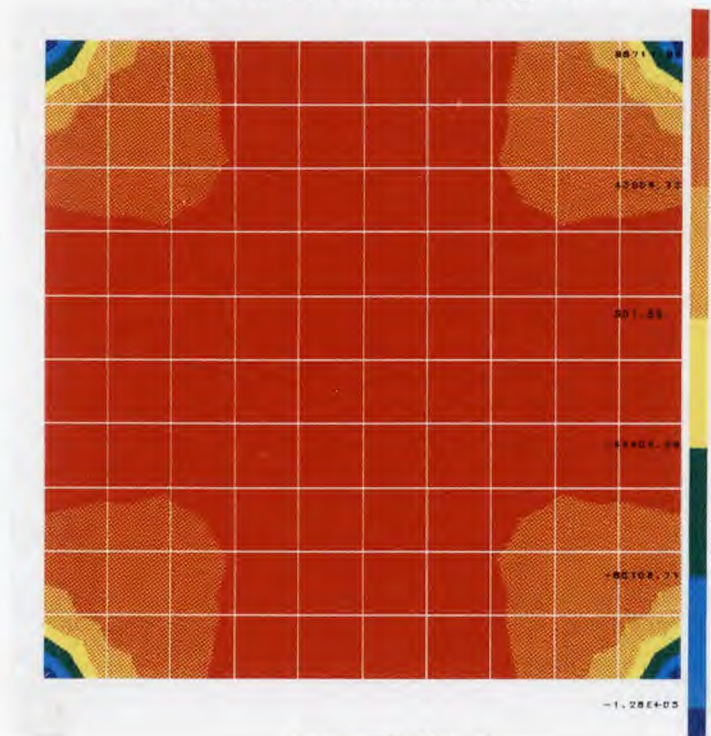

Figure 3.14 New Setting Position of Holder



Stress With the New Handling Position



Stress of Case 2

Figure 3.15 Stress Plot

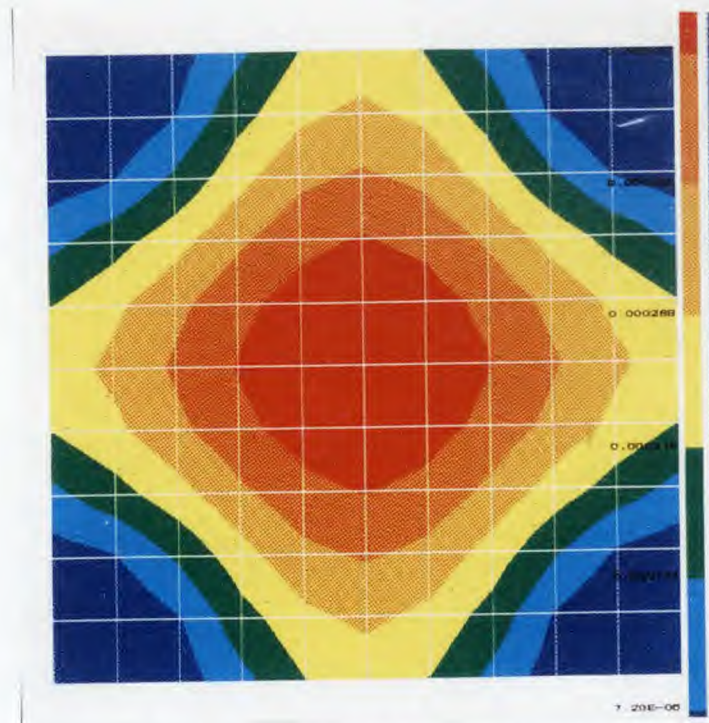

Displacement With the New Handling

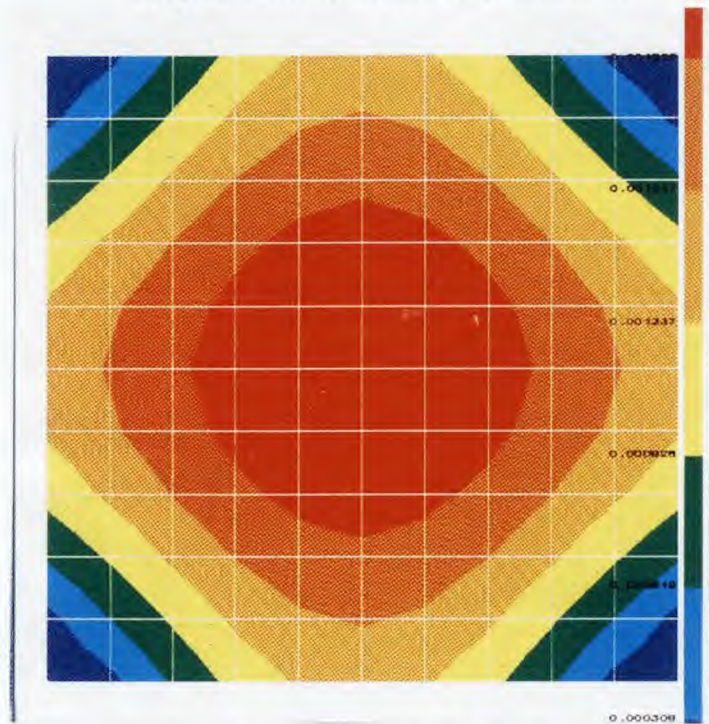

Displacement of Case 1

**Figure 3.16** Displacement Plot

### 3.10 Discussion

After comparing the two kinds of pick-up tools, we find that two-holder pick-up tool may be used for handling small-sized green sheets. If we want to stack or handle large-sized green sheets, we have to use the four-holder pick-up tools. Otherwise the displacement near the registration holes will be too large ( in case 5 ), and the stacking maybe affected for the same green sheets, if it is handled by the two-holder pick-up tools. On the other hand, it is easier to design an adjustable two-holder pick-up tools than to design an adjustable four-holder pick-up tool.

Safe handling relies in great measure upon an ability to predict the circumstance under which failure is likely to occur. The important variables connected with structural failure include the nature of the material; the load configuration; the shape, surface peculiarities, and the characteristics of the surrounding the member (environmental conditions ).

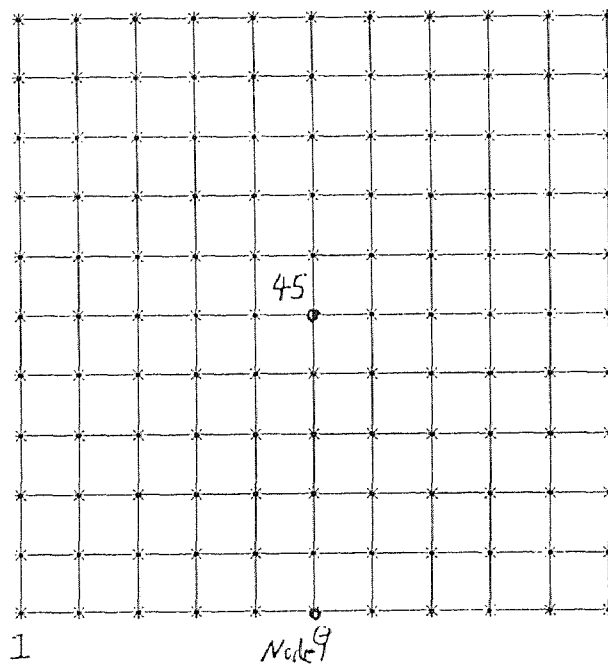

Figure 3.16 Special Nodes On Green Sheet.

We will use the maximum principal stress theory and the maximum shear stress theory to analyze stress data that we obtained in the earlier sections.

### 3.10.1 The Maximum Principal Stress Theory

According to the maximum principal stress theory, a material fails by yielding when the maximum principal stress exceeds the tensile yield strength, or when the minimum principal stress exceeds the compressive yield strength. That is, at the onset of yielding,

We can get the data of stress at each node of System<sub>7</sub>3081 from Appendix Table2, we obtain that the tensile yielding strength is 24.5 MPa, and the compressive yielding strength is 490 MPa ( in Table 2.8 ). We will choose three special nodes ( Node 1, 9, 45)in ( Fig. 3.16 ) of the green sheet to discuss their mechanical behavior when we handle it, because the maximum principle stress occurs at these three nodes.

The first is Node 1, because we set the holder on this node. From Appendix table 2, we find the maximum min principal stress in case 2 is  $-6.775E+5 \text{ kg/m}^2$ .

According to the maximum principal stress theory, we get  $\sigma_{\max}$  as  $-6.775 E+5 \text{ kg/m}^2$  ( $-6.64 \text{ MPa}$  )

$$\sigma_{yp} = 490 \text{ Mpa}$$

$$|\sigma_1| = 6.64 \text{ Mpa}$$

$$\frac{|\sigma_1|}{\sigma_{yp}} = \frac{6,64}{490} = 0.01$$

$$F_s = \frac{\sigma_{yp}}{|\sigma_1|} = 73.8$$

The factor of safety  $N$  is 73.8, the factor is enough to this material, so the four corner is satisfy the request of safety.

The second is node 9, it is at center of edge and the maximum principal stress occur here. This is more damage than the another nodes of green sheet.

The maximum principal stress of green sheet in case 2 is  $1.283E+5 \text{ kg/m}^2$  (  $1.257 \text{ MPa}$  ) at node 9 ( in the Appendix Table 2 ).

We set the  $\sigma_1$  is  $1.257 \text{ MPa}$  and compare with the tensile yielding strength  $\sigma_{yp}$ .

$$\sigma_{yp} = 24.5 \text{ Mpa}$$

$$|\sigma_1| = 1.257 \text{ Mpa}$$

$$\frac{|\sigma_1|}{\sigma_{yp}} = \frac{1.257}{24.5} = 0.051$$

$$F_s = \frac{\sigma_{yp}}{|\sigma_1|} = 19.5$$

The node 9 is still safety from the theory.

The third node 45 is at the center of green sheet, this is the most important area to us, because the all wire is around this area. It will influence all quality of the system. From the calculate in I-DEAS, the maximum principal stress of the node 45 in case 2 is  $8.584E+4$  (  $0.841 \text{ MPa}$  ), we compare to the tensile yielding strength of the green sheet.

$$\sigma_{yp} = 24.5 \text{ Mpa}$$

$$|\sigma_1| = 0.8412 \text{ Mpa}$$

$$\frac{|\sigma_1|}{\sigma_{yp}} = \frac{0.8412}{24.5} = 0.0342$$

$$F_s = \frac{\sigma_{yp}}{|\sigma_1|} = 19.5$$

The node 45 is with the shaded area, it means the wire area is safety by the maximum principal stress theory. There will be no yielding in this green sheet. It is the same as system-3080, we still can get the result in following table:

**Table 3.3** The Factor of Safety

	Number of node	Max. Stress MPa	Yield Stress MPa	Factor of Safety
Case 2	Node 1	-6.64	490	73.8
	Node 9	1.257	24.5	19.5
	Node 45	0.8412	24.5	29.2
Case 4	Node 1	-2.37	490	206.7
	Node 9	0.45	24.5	54.8
	Node 45	0.30	24.5	81.6

Based on the maximum principal stress theory, the four-holder pick-up tool, The four-holder pick-up tools can be used to handing the green sheets.



### 3.10.2 The Maximum Shear Stress Theory

The maximum shear stress theory is an outgrowth of the experimental observation that a ductile material yielding as a result of slip or shear along crystalline planes. This theory predicts that yielding will start when the maximum shear stress in the material equals the maximum shear stress at yielding in a simple tension test. we obtain  $\frac{1}{2}|\sigma_1 - \sigma_3| = \tau_{\max}$

In the case of green sheet stress (  $\sigma_3=0$  ), therefore there are two combinations of stresses to be considered. When  $\sigma_1$  and  $\sigma_2$  are of same sign, the maximum shearing stress is  $\tau_{\max} = \sigma_1/2$  (if  $|\sigma_1| \geq |\sigma_2|$ ) and  $\tau_{\max} = \sigma_2/2$  (if  $|\sigma_2| \geq |\sigma_1|$ ). When  $\sigma_1$  and  $\sigma_2$  are of opposite sign, the maximum shearing stress  $\tau_{\max}$  is  $|\sigma_1 - \sigma_2| / 2$ .

In our cases, the maximum shearing stress is at node 1, the  $\tau_{\max}$  in case 2 ( Appendix Table 2 ) is 2.594E+5 kg/m<sup>2</sup> ( 2.542 MPa ), and 9.296E+4kg/m<sup>2</sup> ( 0.907 MPa ) in Case 4 ( in the Appendix Table 4 ). and the yielding shearing stress  $\tau_{yp}$  is  $\sigma_{yp}/2=24.5/2=12.25$  MPa.

The factor of safety of case 2:

$$FS = \frac{\tau_{yp}}{\tau_{\max}} = \frac{12.25}{2.542} = 4.8$$

The factor of safety of case 4:

$$FS = \frac{\tau_{yp}}{\tau_{\max}} = \frac{12.25}{0.907} = 13.5$$

It is a safe design about the four-holder pick-up tool by the maximum shearing stress theory.

Based on the analysis with the maximum principal stress theory and the maximum shearing stress theory, we find the four holder can be used for handling green sheets. Since

different green sheets have different patterns for their via holes, our stress analysis did not taken the effect of those holes into consideration, therefore, the above results is only used as a first estimate. For more accurate results, the actual holes should also be included in the analysis.

## CHAPTER 4

### CONCEPTUAL DESIGN OF FOUR-HOLDER PICK-UP TOOL

It is important to make the pick-up tools adjustable, so that they can handle different sizes of green sheets. In this chapter, we discuss a conceptual design of four-holder pick-up tool to be used as an end-effector of robot. The typical work size of green sheets is about 90 mm × 90 mm to 160 mm × 160 mm. A robot arm will be used to position and move the tool. Fig. 4.1 shows a SCARA assembly robot that may be used for this purpose. Although two-holder may be used for handling small green sheets, only the design of four-holder adjustable tool with four holders will be discussed.

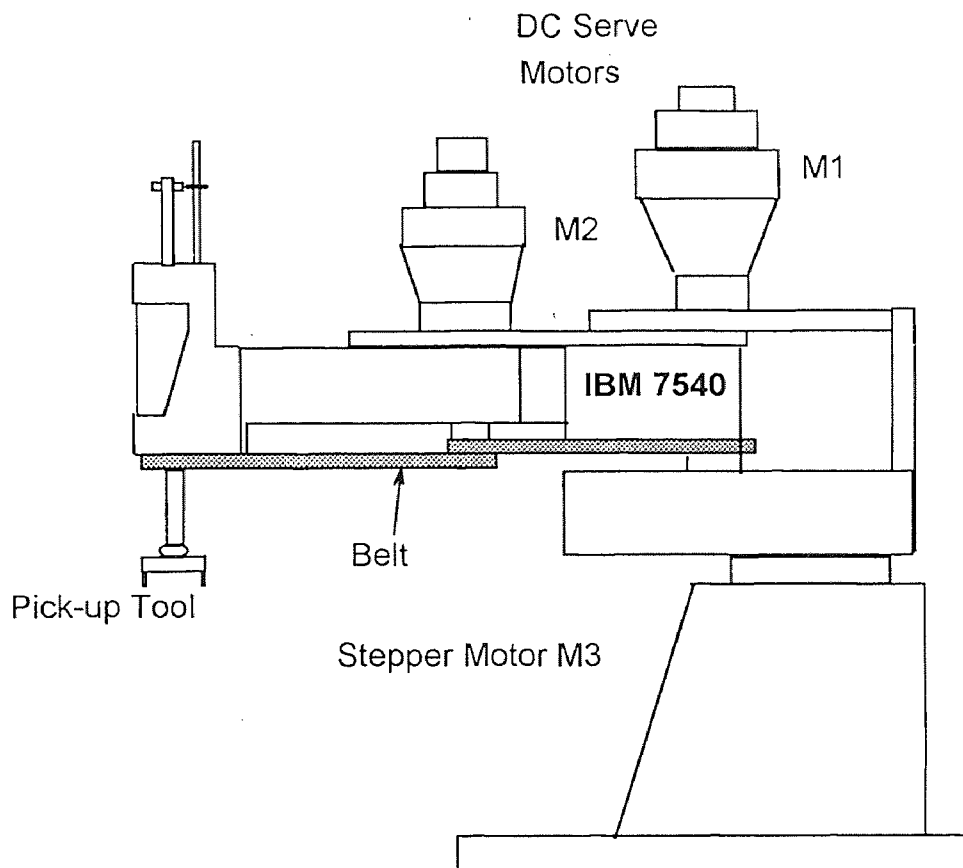

**Figure 4.1** Robots of Material Handling.

Like many pick-up tools used for handling surface mount component, the proposed new tool will use vacuum suction to hold the green sheets. However, our analysis on stress and displacement shows that multiple holders are needed to ensure quality in green sheet-handling. Since the green sheet are produced in various sizes, the distance between the four holders should be made adjustable to accommodate the size change. Therefore, the main design effect will be put on the mechanisms for the adjustment.

A schematic diagram ( Fig. 4.2 ) shows the conceptual design of such mechanism. As can be seen from Fig. 4.2 and Fig. 4.3, the four holders A, B, C, and D are connected together through four lineal sliders, S1, S2, S3 and S4. These sliders provide the necessary movement for adjusting the distance between the holders. The motion of the sliders are controlled by two small electric DC serve motors, through two pairs of pinion-rack mechanisms are used to actuate the sliders.

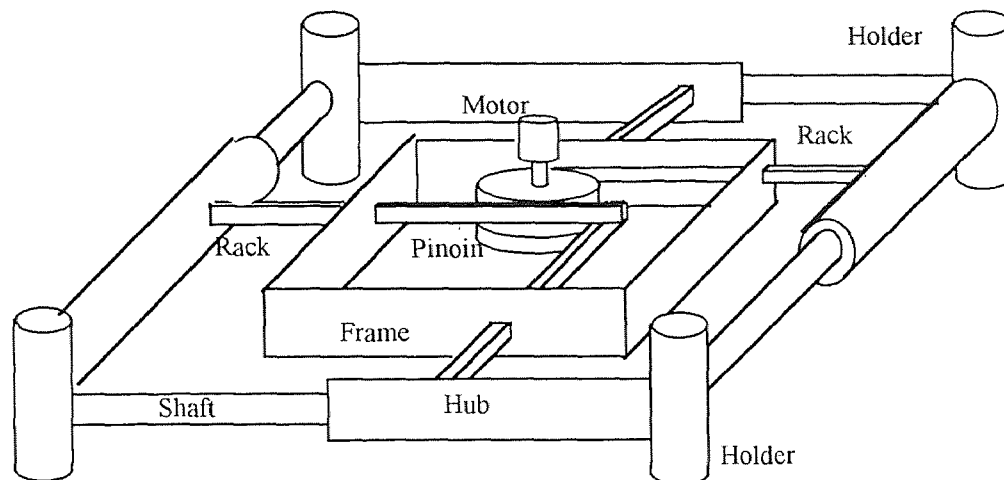

**Figure 4.2** Frame of The Pick-Up tool.

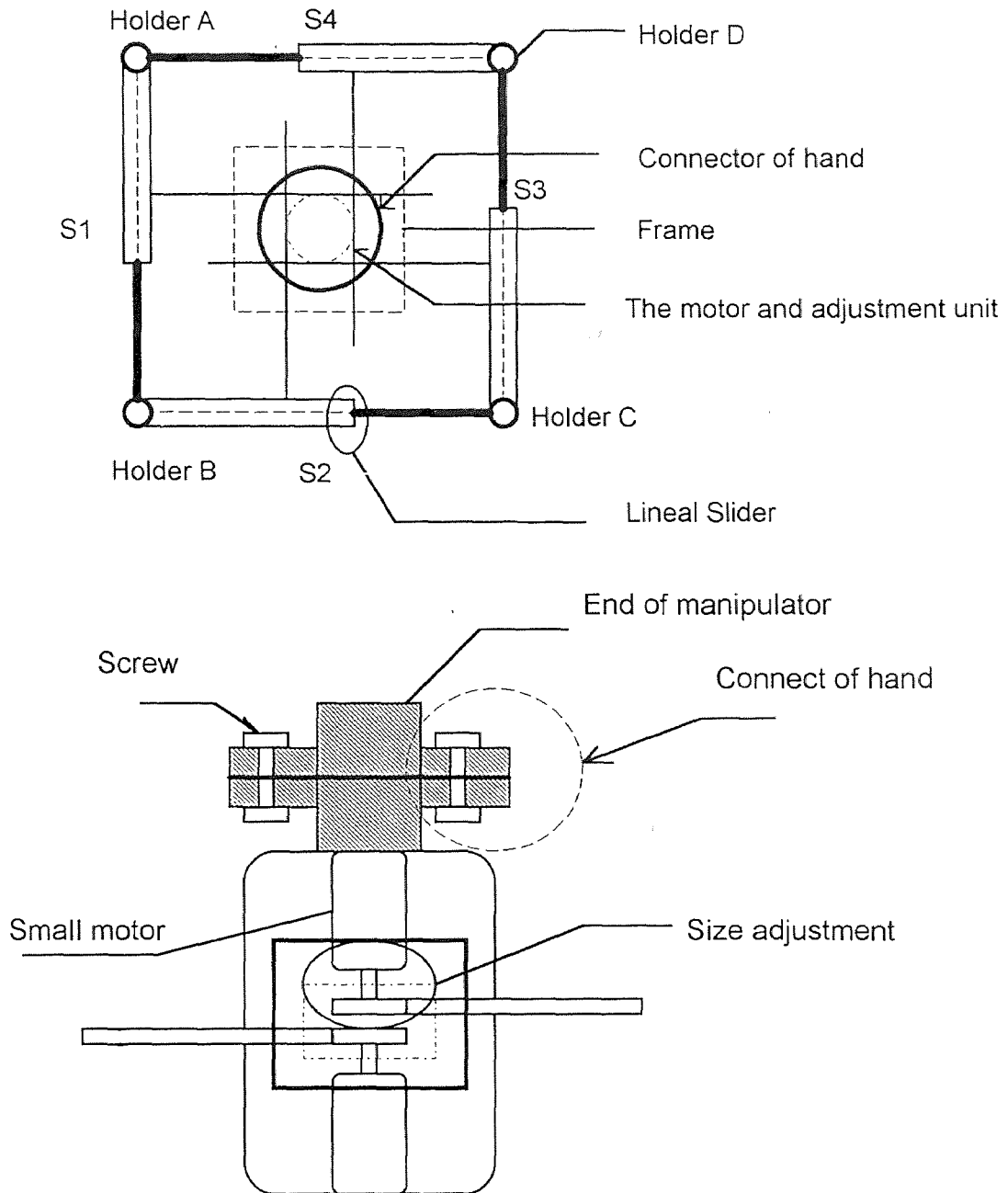

**Figure 4.3** Mechanism of Pick-Up Tool

## CHAPTER 5

### CONCLUSIONS AND RECOMMENDATIONS

We have analyzed the displacement, the principal and shearing stress of the different sized laminated multilayer ceramic green sheets, and compared the different influence of the two-holder and four-holder pick-up tools. The conceptual design of four-holder pick-up tool has been study according to the results given by the work.

After analyzing the stress and displacements, and discussing the conceptual design of a four-holder pick-up tool to handling the green sheets. The future work can be directed in the following aspects:

1. Develop the quality of the robot hand
2. Investigate the change of materials properties while use the robot hand in order to collect data on practical exmples and on relevant works in industry applications.
3. Investigate change of size of laminated green sheet.
4. Discuss the stress and strain of four holders pick-up tool in order to increase its safety.
5. Discuss the inference of holes and wire of green sheets.

## APPENDIX

SDRC I-DEAS VI: FE\_Modeling\_&\_Analysis

02-NOV-

93 12:14:40

none

```

Group ID           : No stored PERMANENT GROUP
Analysis Dataset  : 1 - CASE 1,LOAD 1,DISPLACEMENTS
Report Type       : Contour                               Units           : MG
Dataset Type      : Displacements                         Load Set        : 1
Frame of Reference: Global                               Data Component:
Magnitude
    
```

Node	Displ-X	Displ-Y	Displ-Z	Rot-X	Rot-Y	Rot-Z
1	0.000E+00	0.000E+00	0.000E+00	0.000E+00	0.000E+00	0.000E+00
2	0.000E+00	0.000E+00	0.000E+00	0.000E+00	0.000E+00	0.000E+00
3	0.000E+00	0.000E+00	0.000E+00	0.000E+00	0.000E+00	0.000E+00
4	0.000E+00	0.000E+00	0.000E+00	0.000E+00	0.000E+00	0.000E+00
5	0.000E+00	0.000E+00	2.253E-04	2.853E-02	-3.003E-02	0.000E+00
6	0.000E+00	0.000E+00	6.585E-04	2.099E-02	-2.773E-02	0.000E+00
7	0.000E+00	0.000E+00	1.027E-03	1.828E-02	-2.146E-02	0.000E+00
8	0.000E+00	0.000E+00	1.274E-03	1.560E-02	-1.139E-02	0.000E+00
9	0.000E+00	0.000E+00	1.359E-03	1.486E-02	7.741E-13	0.000E+00
10	0.000E+00	0.000E+00	1.274E-03	1.560E-02	1.139E-02	0.000E+00
11	0.000E+00	0.000E+00	1.027E-03	1.828E-02	2.146E-02	0.000E+00
12	0.000E+00	0.000E+00	6.585E-04	2.099E-02	2.773E-02	0.000E+00
13	0.000E+00	0.000E+00	2.253E-04	2.853E-02	3.003E-02	0.000E+00
14	0.000E+00	0.000E+00	2.253E-04	3.003E-02	2.853E-02	0.000E+00
15	0.000E+00	0.000E+00	6.585E-04	2.773E-02	2.099E-02	0.000E+00
16	0.000E+00	0.000E+00	1.027E-03	2.146E-02	1.828E-02	0.000E+00
17	0.000E+00	0.000E+00	1.274E-03	1.139E-02	1.560E-02	0.000E+00
18	0.000E+00	0.000E+00	1.359E-03	-3.592E-13	1.486E-02	0.000E+00
19	0.000E+00	0.000E+00	1.274E-03	-1.139E-02	1.560E-02	0.000E+00
20	0.000E+00	0.000E+00	1.027E-03	-2.146E-02	1.828E-02	0.000E+00
21	0.000E+00	0.000E+00	6.585E-04	-2.773E-02	2.099E-02	0.000E+00
22	0.000E+00	0.000E+00	2.253E-04	-3.003E-02	2.853E-02	0.000E+00
23	0.000E+00	0.000E+00	2.253E-04	-2.853E-02	3.003E-02	0.000E+00
24	0.000E+00	0.000E+00	6.585E-04	-2.099E-02	2.773E-02	0.000E+00
25	0.000E+00	0.000E+00	1.027E-03	-1.828E-02	2.146E-02	0.000E+00
26	0.000E+00	0.000E+00	1.274E-03	-1.560E-02	1.139E-02	0.000E+00
27	0.000E+00	0.000E+00	1.359E-03	-1.486E-02	5.661E-13	0.000E+00
28	0.000E+00	0.000E+00	1.274E-03	-1.560E-02	-1.139E-02	0.000E+00
29	0.000E+00	0.000E+00	1.027E-03	-1.828E-02	-2.146E-02	0.000E+00
30	0.000E+00	0.000E+00	6.585E-04	-2.099E-02	-2.773E-02	0.000E+00
31	0.000E+00	0.000E+00	2.253E-04	-2.853E-02	-3.003E-02	0.000E+00
32	0.000E+00	0.000E+00	2.253E-04	-3.003E-02	-2.853E-02	0.000E+00

33	0.000E+00	0.000E+00	6.585E-04	-2.773E-02	-2.099E-02	0.000E+00
34	0.000E+00	0.000E+00	1.027E-03	-2.146E-02	-1.828E-02	0.000E+00
35	0.000E+00	0.000E+00	1.274E-03	-1.139E-02	-1.560E-02	0.000E+00
36	0.000E+00	0.000E+00	1.359E-03	-5.671E-14	-1.486E-02	0.000E+00
37	0.000E+00	0.000E+00	1.274E-03	1.139E-02	-1.560E-02	0.000E+00
38	0.000E+00	0.000E+00	1.027E-03	2.146E-02	-1.828E-02	0.000E+00
39	0.000E+00	0.000E+00	6.585E-04	2.773E-02	-2.099E-02	0.000E+00
40	0.000E+00	0.000E+00	2.253E-04	3.003E-02	-2.853E-02	0.000E+00
41	0.000E+00	0.000E+00	1.591E-03	-1.600E-02	1.110E-12	0.000E+00
42	0.000E+00	0.000E+00	1.821E-03	-1.479E-02	1.842E-12	0.000E+00
43	0.000E+00	0.000E+00	2.018E-03	-1.137E-02	2.471E-12	0.000E+00
44	0.000E+00	0.000E+00	2.149E-03	-6.165E-03	3.081E-12	0.000E+00
45	0.000E+00	0.000E+00	2.196E-03	-1.570E-12	3.599E-12	0.000E+00
46	0.000E+00	0.000E+00	2.149E-03	6.165E-03	3.588E-12	0.000E+00
47	0.000E+00	0.000E+00	2.018E-03	1.137E-02	3.093E-12	0.000E+00
48	0.000E+00	0.000E+00	1.821E-03	1.479E-02	2.502E-12	0.000E+00
49	0.000E+00	0.000E+00	1.591E-03	1.600E-02	1.616E-12	0.000E+00
50	0.000E+00	0.000E+00	2.149E-03	-1.691E-12	-6.165E-03	0.000E+00
51	0.000E+00	0.000E+00	2.018E-03	-1.344E-12	-1.137E-02	0.000E+00
52	0.000E+00	0.000E+00	1.821E-03	-9.693E-13	-1.479E-02	0.000E+00
53	0.000E+00	0.000E+00	1.591E-03	-5.080E-13	-1.600E-02	0.000E+00
54	0.000E+00	0.000E+00	1.963E-03	-1.186E-02	-7.282E-03	0.000E+00
55	0.000E+00	0.000E+00	1.808E-03	-1.343E-02	-1.343E-02	0.000E+00
56	0.000E+00	0.000E+00	1.577E-03	-1.579E-02	-1.738E-02	0.000E+00
57	0.000E+00	0.000E+00	1.305E-03	-1.829E-02	-1.879E-02	0.000E+00
58	0.000E+00	0.000E+00	1.305E-03	-2.046E-02	-2.046E-02	0.000E+00
59	0.000E+00	0.000E+00	9.836E-04	-2.236E-02	-2.462E-02	0.000E+00
60	0.000E+00	0.000E+00	1.758E-03	-1.545E-02	-8.428E-03	0.000E+00
61	0.000E+00	0.000E+00	1.577E-03	-1.738E-02	-1.579E-02	0.000E+00
62	0.000E+00	0.000E+00	1.305E-03	-1.879E-02	-1.829E-02	0.000E+00
63	0.000E+00	0.000E+00	1.517E-03	-1.678E-02	-9.867E-03	0.000E+00
64	0.000E+00	0.000E+00	9.836E-04	-2.462E-02	-2.236E-02	0.000E+00
65	0.000E+00	0.000E+00	6.191E-04	-2.398E-02	-2.398E-02	0.000E+00
66	0.000E+00	0.000E+00	2.101E-03	-6.480E-03	-6.480E-03	0.000E+00
67	0.000E+00	0.000E+00	1.963E-03	-7.282E-03	-1.186E-02	0.000E+00
68	0.000E+00	0.000E+00	1.758E-03	-8.428E-03	-1.545E-02	0.000E+00
69	0.000E+00	0.000E+00	1.517E-03	-9.867E-03	-1.678E-02	0.000E+00
70	0.000E+00	0.000E+00	1.963E-03	7.282E-03	-1.186E-02	0.000E+00
71	0.000E+00	0.000E+00	1.808E-03	1.343E-02	-1.343E-02	0.000E+00
72	0.000E+00	0.000E+00	1.577E-03	1.738E-02	-1.579E-02	0.000E+00
73	0.000E+00	0.000E+00	1.305E-03	1.879E-02	-1.829E-02	0.000E+00
74	0.000E+00	0.000E+00	1.305E-03	2.046E-02	-2.046E-02	0.000E+00
75	0.000E+00	0.000E+00	9.836E-04	2.462E-02	-2.236E-02	0.000E+00
76	0.000E+00	0.000E+00	1.758E-03	8.428E-03	-1.545E-02	0.000E+00
77	0.000E+00	0.000E+00	1.577E-03	1.579E-02	-1.738E-02	0.000E+00
78	0.000E+00	0.000E+00	1.305E-03	1.829E-02	-1.879E-02	0.000E+00
79	0.000E+00	0.000E+00	1.517E-03	9.867E-03	-1.678E-02	0.000E+00
80	0.000E+00	0.000E+00	9.836E-04	2.236E-02	-2.462E-02	0.000E+00
81	0.000E+00	0.000E+00	6.191E-04	2.398E-02	-2.398E-02	0.000E+00
82	0.000E+00	0.000E+00	2.101E-03	6.480E-03	-6.480E-03	0.000E+00



83	0.000E+00	0.000E+00	1.963E-03	1.186E-02	-7.282E-03	0.000E+00
84	0.000E+00	0.000E+00	1.758E-03	1.545E-02	-8.428E-03	0.000E+00
85	0.000E+00	0.000E+00	1.517E-03	1.678E-02	-9.867E-03	0.000E+00
86	0.000E+00	0.000E+00	1.591E-03	-5.238E-13	1.600E-02	0.000E+00
87	0.000E+00	0.000E+00	1.821E-03	-8.435E-13	1.479E-02	0.000E+00
88	0.000E+00	0.000E+00	2.018E-03	-9.916E-13	1.137E-02	0.000E+00
89	0.000E+00	0.000E+00	2.149E-03	-1.213E-12	6.165E-03	0.000E+00
90	0.000E+00	0.000E+00	1.305E-03	-1.829E-02	1.879E-02	0.000E+00
91	0.000E+00	0.000E+00	1.577E-03	-1.579E-02	1.738E-02	0.000E+00
92	0.000E+00	0.000E+00	1.808E-03	-1.343E-02	1.343E-02	0.000E+00
93	0.000E+00	0.000E+00	1.963E-03	-1.186E-02	7.282E-03	0.000E+00
94	0.000E+00	0.000E+00	1.577E-03	-1.738E-02	1.579E-02	0.000E+00
95	0.000E+00	0.000E+00	1.305E-03	-1.879E-02	1.829E-02	0.000E+00
96	0.000E+00	0.000E+00	9.836E-04	-2.236E-02	2.462E-02	0.000E+00
97	0.000E+00	0.000E+00	6.191E-04	-2.398E-02	2.398E-02	0.000E+00
98	0.000E+00	0.000E+00	9.836E-04	-2.462E-02	2.236E-02	0.000E+00
99	0.000E+00	0.000E+00	1.305E-03	-2.046E-02	2.046E-02	0.000E+00
100	0.000E+00	0.000E+00	1.758E-03	-1.545E-02	8.428E-03	0.000E+00
101	0.000E+00	0.000E+00	1.517E-03	-1.678E-02	9.867E-03	0.000E+00
102	0.000E+00	0.000E+00	1.517E-03	-9.867E-03	1.678E-02	0.000E+00
103	0.000E+00	0.000E+00	1.758E-03	-8.428E-03	1.545E-02	0.000E+00
104	0.000E+00	0.000E+00	1.963E-03	-7.282E-03	1.186E-02	0.000E+00
105	0.000E+00	0.000E+00	2.101E-03	-6.480E-03	6.480E-03	0.000E+00
106	0.000E+00	0.000E+00	1.758E-03	8.428E-03	1.545E-02	0.000E+00
107	0.000E+00	0.000E+00	1.577E-03	1.579E-02	1.738E-02	0.000E+00
108	0.000E+00	0.000E+00	1.305E-03	2.046E-02	2.046E-02	0.000E+00
109	0.000E+00	0.000E+00	9.836E-04	2.236E-02	2.462E-02	0.000E+00
110	0.000E+00	0.000E+00	1.577E-03	1.738E-02	1.579E-02	0.000E+00
111	0.000E+00	0.000E+00	1.758E-03	1.545E-02	8.428E-03	0.000E+00
112	0.000E+00	0.000E+00	1.963E-03	1.186E-02	7.282E-03	0.000E+00
113	0.000E+00	0.000E+00	2.101E-03	6.480E-03	6.480E-03	0.000E+00
114	0.000E+00	0.000E+00	1.963E-03	7.282E-03	1.186E-02	0.000E+00
115	0.000E+00	0.000E+00	1.808E-03	1.343E-02	1.343E-02	0.000E+00
116	0.000E+00	0.000E+00	1.305E-03	1.879E-02	1.829E-02	0.000E+00
117	0.000E+00	0.000E+00	1.517E-03	1.678E-02	9.867E-03	0.000E+00
118	0.000E+00	0.000E+00	1.517E-03	9.867E-03	1.678E-02	0.000E+00
119	0.000E+00	0.000E+00	1.305E-03	1.829E-02	1.879E-02	0.000E+00
120	0.000E+00	0.000E+00	9.836E-04	2.462E-02	2.236E-02	0.000E+00
121	0.000E+00	0.000E+00	6.191E-04	2.398E-02	2.398E-02	0.000E+00

	1	1	45	14	13	1
Maximum	0.000E+00	0.000E+00	2.196E-03	3.003E-02	3.003E-02	
0.000E+00						
	1	1	1	22	5	1
Minimum	0.000E+00	0.000E+00	0.000E+00	-3.003E-02	-3.003E-02	
0.000E+00						
Average	0.000E+00	0.000E+00	1.319E-03	-2.001E-10	1.232E-10	

## CASE 2

SDRC I-DEAS VI: FE\_Modeling\_&amp;\_Analysis

02-NOV-93 12:17:31

none

Group ID : No stored PERMANENT GROUP  
 Analysis Dataset : 2 - CASE 1,LOAD 1,STRESSES  
 Report Type : Contour Units : MG  
 Dataset Type : Stress Load Set : 1  
 Frame of Reference: Global Data Component:  
 Max Prin  
 Surface Type : Top

Node	Max Prin	Mid Prin	Min Prin	Max Shear	Von Mises
1	-1.587E+05	0.000E+00	-6.775E+05	2.594E+05	6.137E+05
2	-1.587E+05	0.000E+00	-6.775E+05	2.594E+05	6.137E+05
3	-1.587E+05	0.000E+00	-6.775E+05	2.594E+05	6.137E+05
4	-1.587E+05	0.000E+00	-6.775E+05	2.594E+05	6.137E+05
5	2.131E+04	0.000E+00	-1.509E+05	8.612E+04	1.626E+05
6	6.573E+04	0.000E+00	-2.511E+04	4.542E+04	8.124E+04
7	1.009E+05	0.000E+00	5.663E+03	4.762E+04	9.820E+04
8	1.226E+05	0.000E+00	1.044E+04	5.606E+04	1.177E+05
9	1.283E+05	0.000E+00	1.447E+04	5.691E+04	1.217E+05
10	1.226E+05	0.000E+00	1.044E+04	5.606E+04	1.177E+05
11	1.009E+05	0.000E+00	5.663E+03	4.762E+04	9.820E+04
12	6.573E+04	0.000E+00	-2.511E+04	4.542E+04	8.124E+04
13	2.131E+04	0.000E+00	-1.509E+05	8.612E+04	1.626E+05
14	2.131E+04	0.000E+00	-1.509E+05	8.612E+04	1.626E+05
15	6.573E+04	0.000E+00	-2.511E+04	4.542E+04	8.124E+04
16	1.009E+05	0.000E+00	5.663E+03	4.762E+04	9.820E+04
17	1.226E+05	0.000E+00	1.044E+04	5.606E+04	1.177E+05
18	1.283E+05	0.000E+00	1.447E+04	5.691E+04	1.217E+05
19	1.226E+05	0.000E+00	1.044E+04	5.606E+04	1.177E+05
20	1.009E+05	0.000E+00	5.663E+03	4.762E+04	9.820E+04
21	6.573E+04	0.000E+00	-2.511E+04	4.542E+04	8.124E+04
22	2.131E+04	0.000E+00	-1.509E+05	8.612E+04	1.626E+05
23	2.131E+04	0.000E+00	-1.509E+05	8.612E+04	1.626E+05
24	6.573E+04	0.000E+00	-2.511E+04	4.542E+04	8.124E+04
25	1.009E+05	0.000E+00	5.663E+03	4.762E+04	9.820E+04
26	1.226E+05	0.000E+00	1.044E+04	5.606E+04	1.177E+05
27	1.283E+05	0.000E+00	1.447E+04	5.691E+04	1.217E+05
28	1.226E+05	0.000E+00	1.044E+04	5.606E+04	1.177E+05
29	1.009E+05	0.000E+00	5.663E+03	4.762E+04	9.820E+04
30	6.573E+04	0.000E+00	-2.511E+04	4.542E+04	8.124E+04

31	2.131E+04	0.000E+00	-1.509E+05	8.612E+04	1.626E+05
32	2.131E+04	0.000E+00	-1.509E+05	8.612E+04	1.626E+05
33	6.573E+04	0.000E+00	-2.511E+04	4.542E+04	8.124E+04
34	1.009E+05	0.000E+00	5.663E+03	4.762E+04	9.820E+04
35	1.226E+05	0.000E+00	1.044E+04	5.606E+04	1.177E+05
36	1.283E+05	0.000E+00	1.447E+04	5.691E+04	1.217E+05
37	1.226E+05	0.000E+00	1.044E+04	5.606E+04	1.177E+05
38	1.009E+05	0.000E+00	5.663E+03	4.762E+04	9.820E+04
39	6.573E+04	0.000E+00	-2.511E+04	4.542E+04	8.124E+04
40	2.131E+04	0.000E+00	-1.509E+05	8.612E+04	1.626E+05
41	1.136E+05	0.000E+00	2.426E+04	4.468E+04	1.036E+05
42	1.026E+05	0.000E+00	4.697E+04	2.780E+04	8.893E+04
43	9.423E+04	0.000E+00	6.723E+04	1.350E+04	8.405E+04
44	8.831E+04	0.000E+00	8.110E+04	3.602E+03	8.494E+04
45	8.584E+04	0.000E+00	8.584E+04	2.238E-06	8.584E+04
46	8.831E+04	0.000E+00	8.110E+04	3.602E+03	8.494E+04
47	9.423E+04	0.000E+00	6.723E+04	1.350E+04	8.405E+04
48	1.026E+05	0.000E+00	4.697E+04	2.780E+04	8.893E+04

1

Page 2

SDRC I-DEAS VI: FE\_Modeling\_&\_Analysis  
 93 12:17:31  
 none

02-NOV-

Node	Max Prin	Mid Prin	Min Prin	Max Shear	Von Mises
49	1.136E+05	0.000E+00	2.426E+04	4.468E+04	1.036E+05
50	8.831E+04	0.000E+00	8.110E+04	3.602E+03	8.494E+04
51	9.423E+04	0.000E+00	6.723E+04	1.350E+04	8.405E+04
52	1.026E+05	0.000E+00	4.697E+04	2.780E+04	8.893E+04
53	1.136E+05	0.000E+00	2.426E+04	4.468E+04	1.036E+05
54	9.162E+04	0.000E+00	6.435E+04	1.364E+04	8.148E+04
55	8.813E+04	0.000E+00	5.243E+04	1.785E+04	7.678E+04
56	8.764E+04	0.000E+00	3.346E+04	2.709E+04	7.660E+04
57	9.502E+04	0.000E+00	1.392E+04	4.055E+04	8.888E+04
58	7.864E+04	0.000E+00	1.283E+04	3.290E+04	7.307E+04
59	5.225E+04	0.000E+00	-8.999E+03	3.062E+04	5.728E+04
60	9.944E+04	0.000E+00	4.472E+04	2.736E+04	8.626E+04
61	8.764E+04	0.000E+00	3.346E+04	2.709E+04	7.660E+04
62	9.502E+04	0.000E+00	1.392E+04	4.055E+04	8.888E+04
63	1.075E+05	0.000E+00	2.097E+04	4.324E+04	9.866E+04
64	5.225E+04	0.000E+00	-8.999E+03	3.062E+04	5.728E+04
65	6.213E+04	0.000E+00	-7.604E+03	3.487E+04	6.626E+04
66	8.767E+04	0.000E+00	7.751E+04	5.079E+03	8.305E+04

67	9.162E+04	0.000E+00	6.435E+04	1.364E+04	8.148E+04
68	9.944E+04	0.000E+00	4.472E+04	2.736E+04	8.626E+04
69	1.075E+05	0.000E+00	2.097E+04	4.324E+04	9.866E+04
70	9.162E+04	0.000E+00	6.435E+04	1.364E+04	8.148E+04
71	8.813E+04	0.000E+00	5.243E+04	1.785E+04	7.678E+04
72	8.764E+04	0.000E+00	3.346E+04	2.709E+04	7.660E+04
73	9.502E+04	0.000E+00	1.392E+04	4.055E+04	8.888E+04
74	7.864E+04	0.000E+00	1.283E+04	3.290E+04	7.307E+04
75	5.225E+04	0.000E+00	-8.999E+03	3.062E+04	5.728E+04
76	9.944E+04	0.000E+00	4.472E+04	2.736E+04	8.626E+04
77	8.764E+04	0.000E+00	3.346E+04	2.709E+04	7.660E+04
78	9.502E+04	0.000E+00	1.392E+04	4.055E+04	8.888E+04
79	1.075E+05	0.000E+00	2.097E+04	4.324E+04	9.866E+04
80	5.225E+04	0.000E+00	-8.999E+03	3.062E+04	5.728E+04
81	6.213E+04	0.000E+00	-7.604E+03	3.487E+04	6.626E+04
82	8.767E+04	0.000E+00	7.751E+04	5.079E+03	8.305E+04
83	9.162E+04	0.000E+00	6.435E+04	1.364E+04	8.148E+04
84	9.944E+04	0.000E+00	4.472E+04	2.736E+04	8.626E+04
85	1.075E+05	0.000E+00	2.097E+04	4.324E+04	9.866E+04
86	1.136E+05	0.000E+00	2.426E+04	4.468E+04	1.036E+05
87	1.026E+05	0.000E+00	4.697E+04	2.780E+04	8.893E+04
88	9.423E+04	0.000E+00	6.723E+04	1.350E+04	8.405E+04
89	8.831E+04	0.000E+00	8.110E+04	3.602E+03	8.494E+04
90	9.502E+04	0.000E+00	1.392E+04	4.055E+04	8.888E+04
91	8.764E+04	0.000E+00	3.346E+04	2.709E+04	7.660E+04
92	8.813E+04	0.000E+00	5.243E+04	1.785E+04	7.678E+04
93	9.162E+04	0.000E+00	6.435E+04	1.364E+04	8.148E+04
94	8.764E+04	0.000E+00	3.346E+04	2.709E+04	7.660E+04
95	9.502E+04	0.000E+00	1.392E+04	4.055E+04	8.888E+04
96	5.225E+04	0.000E+00	-8.999E+03	3.062E+04	5.728E+04
97	6.213E+04	0.000E+00	-7.604E+03	3.487E+04	6.626E+04
98	5.225E+04	0.000E+00	-8.999E+03	3.062E+04	5.728E+04
99	7.864E+04	0.000E+00	1.283E+04	3.290E+04	7.307E+04
100	9.944E+04	0.000E+00	4.472E+04	2.736E+04	8.626E+04
101	1.075E+05	0.000E+00	2.097E+04	4.324E+04	9.866E+04
102	1.075E+05	0.000E+00	2.097E+04	4.324E+04	9.866E+04
103	9.944E+04	0.000E+00	4.472E+04	2.736E+04	8.626E+04

1

Page 3

SDRC I-DEAS VI: FE\_Modeling\_&\_Analysis  
93 12:17:31  
none

02-NOV-

Node	Max Prin	Mid Prin	Min Prin	Max Shear	Von Mises
------	----------	----------	----------	-----------	-----------

104	9.162E+04	0.000E+00	6.435E+04	1.364E+04	8.148E+04
105	8.767E+04	0.000E+00	7.751E+04	5.079E+03	8.305E+04
106	9.944E+04	0.000E+00	4.472E+04	2.736E+04	8.626E+04
107	8.764E+04	0.000E+00	3.346E+04	2.709E+04	7.660E+04
108	7.864E+04	0.000E+00	1.283E+04	3.290E+04	7.307E+04
109	5.225E+04	0.000E+00	-8.999E+03	3.062E+04	5.728E+04
110	8.764E+04	0.000E+00	3.346E+04	2.709E+04	7.660E+04
111	9.944E+04	0.000E+00	4.472E+04	2.736E+04	8.626E+04
112	9.162E+04	0.000E+00	6.435E+04	1.364E+04	8.148E+04
113	8.767E+04	0.000E+00	7.751E+04	5.079E+03	8.305E+04
114	9.162E+04	0.000E+00	6.435E+04	1.364E+04	8.148E+04
115	8.813E+04	0.000E+00	5.243E+04	1.785E+04	7.678E+04
116	9.502E+04	0.000E+00	1.392E+04	4.055E+04	8.888E+04
117	1.075E+05	0.000E+00	2.097E+04	4.324E+04	9.866E+04
118	1.075E+05	0.000E+00	2.097E+04	4.324E+04	9.866E+04
119	9.502E+04	0.000E+00	1.392E+04	4.055E+04	8.888E+04
120	5.225E+04	0.000E+00	-8.999E+03	3.062E+04	5.728E+04
121	6.213E+04	0.000E+00	-7.604E+03	3.487E+04	6.626E+04
	9	1	45	1	1
Maximum	1.283E+05	0.000E+00	8.584E+04	2.594E+05	6.137E+05
	1	1	1	45	59
Minimum	-1.587E+05	0.000E+00	-6.775E+05	2.238E-06	5.728E+04
Average	7.915E+04	0.000E+00	-8.920E+03	4.403E+04	1.096E+05

## APPENDIX TABLE 3

CASE 3

SDRC I-DEAS VI: FE\_Modeling\_&amp;\_Analysis

01-NOV-

93 21:23:31

n90

Group ID : No stored PERMANENT GROUP  
 Analysis Dataset : 1 - CASE 1,LOAD 1,DISPLACEMENTS  
 Report Type : Contour Units : MG  
 Dataset Type : Displacements Load Set : 1  
 Frame of Reference: Global Data Component:  
 Magnitude

Node	Displ-X	Displ-Y	Displ-Z	Rot-X	Rot-Y	Rot-Z
1	0.000E+00	0.000E+00	0.000E+00	0.000E+00	0.000E+00	0.000E+00
2	0.000E+00	0.000E+00	0.000E+00	0.000E+00	0.000E+00	0.000E+00
3	0.000E+00	0.000E+00	0.000E+00	0.000E+00	0.000E+00	0.000E+00
4	0.000E+00	0.000E+00	0.000E+00	0.000E+00	0.000E+00	0.000E+00
5	0.000E+00	0.000E+00	2.908E-05	6.135E-03	-6.457E-03	0.000E+00
6	0.000E+00	0.000E+00	8.497E-05	4.514E-03	-5.962E-03	0.000E+00
7	0.000E+00	0.000E+00	1.326E-04	3.930E-03	-4.614E-03	0.000E+00
8	0.000E+00	0.000E+00	1.644E-04	3.355E-03	-2.448E-03	0.000E+00
9	0.000E+00	0.000E+00	1.754E-04	3.196E-03	1.844E-11	0.000E+00
10	0.000E+00	0.000E+00	1.644E-04	3.355E-03	2.448E-03	0.000E+00
11	0.000E+00	0.000E+00	1.326E-04	3.930E-03	4.614E-03	0.000E+00
12	0.000E+00	0.000E+00	8.497E-05	4.514E-03	5.962E-03	0.000E+00
13	0.000E+00	0.000E+00	2.908E-05	6.135E-03	6.457E-03	0.000E+00
14	0.000E+00	0.000E+00	2.908E-05	6.457E-03	6.135E-03	0.000E+00
15	0.000E+00	0.000E+00	8.497E-05	5.962E-03	4.514E-03	0.000E+00
16	0.000E+00	0.000E+00	1.326E-04	4.614E-03	3.930E-03	0.000E+00
17	0.000E+00	0.000E+00	1.644E-04	2.448E-03	3.355E-03	0.000E+00
18	0.000E+00	0.000E+00	1.754E-04	-1.840E-11	3.196E-03	0.000E+00
19	0.000E+00	0.000E+00	1.644E-04	-2.448E-03	3.355E-03	0.000E+00
20	0.000E+00	0.000E+00	1.326E-04	-4.614E-03	3.930E-03	0.000E+00
21	0.000E+00	0.000E+00	8.497E-05	-5.962E-03	4.514E-03	0.000E+00
22	0.000E+00	0.000E+00	2.908E-05	-6.457E-03	6.135E-03	0.000E+00
23	0.000E+00	0.000E+00	2.908E-05	-6.135E-03	6.457E-03	0.000E+00
24	0.000E+00	0.000E+00	8.497E-05	-4.514E-03	5.962E-03	0.000E+00
25	0.000E+00	0.000E+00	1.326E-04	-3.930E-03	4.614E-03	0.000E+00
26	0.000E+00	0.000E+00	1.644E-04	-3.355E-03	2.448E-03	0.000E+00
27	0.000E+00	0.000E+00	1.754E-04	-3.196E-03	1.846E-11	0.000E+00
28	0.000E+00	0.000E+00	1.644E-04	-3.355E-03	-2.448E-03	0.000E+00
29	0.000E+00	0.000E+00	1.326E-04	-3.930E-03	-4.614E-03	0.000E+00
30	0.000E+00	0.000E+00	8.497E-05	-4.514E-03	-5.962E-03	0.000E+00
31	0.000E+00	0.000E+00	2.908E-05	-6.135E-03	-6.457E-03	0.000E+00
32	0.000E+00	0.000E+00	2.908E-05	-6.457E-03	-6.135E-03	0.000E+00
33	0.000E+00	0.000E+00	8.497E-05	-5.962E-03	-4.514E-03	0.000E+00

34	0.000E+00	0.000E+00	1.326E-04	-4.614E-03	-3.930E-03	0.000E+00
35	0.000E+00	0.000E+00	1.644E-04	-2.448E-03	-3.355E-03	0.000E+00
36	0.000E+00	0.000E+00	1.754E-04	-1.841E-11	-3.196E-03	0.000E+00
37	0.000E+00	0.000E+00	1.644E-04	2.448E-03	-3.355E-03	0.000E+00
38	0.000E+00	0.000E+00	1.326E-04	4.614E-03	-3.930E-03	0.000E+00
39	0.000E+00	0.000E+00	8.497E-05	5.962E-03	-4.514E-03	0.000E+00
40	0.000E+00	0.000E+00	2.908E-05	6.457E-03	-6.135E-03	0.000E+00
41	0.000E+00	0.000E+00	2.052E-04	-3.440E-03	3.873E-11	0.000E+00
42	0.000E+00	0.000E+00	2.350E-04	-3.181E-03	5.458E-11	0.000E+00
43	0.000E+00	0.000E+00	2.603E-04	-2.446E-03	6.800E-11	0.000E+00
44	0.000E+00	0.000E+00	2.773E-04	-1.326E-03	7.491E-11	0.000E+00
45	0.000E+00	0.000E+00	2.833E-04	-7.772E-11	7.794E-11	0.000E+00
46	0.000E+00	0.000E+00	2.773E-04	1.326E-03	7.492E-11	0.000E+00
47	0.000E+00	0.000E+00	2.603E-04	2.446E-03	6.801E-11	0.000E+00
48	0.000E+00	0.000E+00	2.350E-04	3.181E-03	5.458E-11	0.000E+00
49	0.000E+00	0.000E+00	2.052E-04	3.440E-03	3.871E-11	0.000E+00
50	0.000E+00	0.000E+00	2.773E-04	-7.472E-11	-1.326E-03	0.000E+00
51	0.000E+00	0.000E+00	2.603E-04	-6.784E-11	-2.446E-03	0.000E+00
52	0.000E+00	0.000E+00	2.350E-04	-5.445E-11	-3.181E-03	0.000E+00
53	0.000E+00	0.000E+00	2.052E-04	-3.863E-11	-3.440E-03	0.000E+00
54	0.000E+00	0.000E+00	2.533E-04	-2.551E-03	-1.566E-03	0.000E+00
55	0.000E+00	0.000E+00	2.333E-04	-2.889E-03	-2.889E-03	0.000E+00
56	0.000E+00	0.000E+00	2.034E-04	-3.395E-03	-3.737E-03	0.000E+00
57	0.000E+00	0.000E+00	1.684E-04	-3.933E-03	-4.041E-03	0.000E+00
58	0.000E+00	0.000E+00	1.684E-04	-4.400E-03	-4.400E-03	0.000E+00
59	0.000E+00	0.000E+00	1.269E-04	-4.808E-03	-5.293E-03	0.000E+00
60	0.000E+00	0.000E+00	1.684E-04	-4.041E-03	-3.933E-03	0.000E+00
61	0.000E+00	0.000E+00	1.957E-04	-3.608E-03	-2.122E-03	0.000E+00
62	0.000E+00	0.000E+00	2.269E-04	-3.322E-03	-1.812E-03	0.000E+00
63	0.000E+00	0.000E+00	2.034E-04	-3.737E-03	-3.395E-03	0.000E+00
64	0.000E+00	0.000E+00	1.269E-04	-5.293E-03	-4.808E-03	0.000E+00
65	0.000E+00	0.000E+00	7.989E-05	-5.156E-03	-5.156E-03	0.000E+00
66	0.000E+00	0.000E+00	2.710E-04	-1.393E-03	-1.393E-03	0.000E+00
67	0.000E+00	0.000E+00	2.533E-04	-1.566E-03	-2.551E-03	0.000E+00
68	0.000E+00	0.000E+00	2.269E-04	-1.812E-03	-3.322E-03	0.000E+00
69	0.000E+00	0.000E+00	1.957E-04	-2.122E-03	-3.608E-03	0.000E+00
70	0.000E+00	0.000E+00	2.533E-04	1.566E-03	-2.551E-03	0.000E+00
71	0.000E+00	0.000E+00	2.333E-04	2.889E-03	-2.889E-03	0.000E+00
72	0.000E+00	0.000E+00	2.034E-04	3.737E-03	-3.395E-03	0.000E+00
73	0.000E+00	0.000E+00	1.684E-04	4.041E-03	-3.933E-03	0.000E+00
74	0.000E+00	0.000E+00	1.684E-04	4.400E-03	-4.400E-03	0.000E+00
75	0.000E+00	0.000E+00	1.269E-04	5.293E-03	-4.808E-03	0.000E+00
76	0.000E+00	0.000E+00	1.684E-04	3.933E-03	-4.041E-03	0.000E+00
77	0.000E+00	0.000E+00	1.957E-04	2.122E-03	-3.608E-03	0.000E+00
78	0.000E+00	0.000E+00	2.269E-04	1.812E-03	-3.322E-03	0.000E+00
79	0.000E+00	0.000E+00	2.034E-04	3.395E-03	-3.737E-03	0.000E+00
80	0.000E+00	0.000E+00	1.269E-04	4.808E-03	-5.293E-03	0.000E+00
81	0.000E+00	0.000E+00	7.989E-05	5.156E-03	-5.156E-03	0.000E+00
82	0.000E+00	0.000E+00	2.710E-04	1.393E-03	-1.393E-03	0.000E+00
83	0.000E+00	0.000E+00	2.533E-04	2.551E-03	-1.566E-03	0.000E+00

84	0.000E+00	0.000E+00	2.269E-04	3.322E-03	-1.812E-03	0.000E+00
85	0.000E+00	0.000E+00	1.957E-04	3.608E-03	-2.122E-03	0.000E+00
86	0.000E+00	0.000E+00	2.052E-04	-3.863E-11	3.440E-03	0.000E+00
87	0.000E+00	0.000E+00	2.350E-04	-5.445E-11	3.181E-03	0.000E+00
88	0.000E+00	0.000E+00	2.603E-04	-6.783E-11	2.446E-03	0.000E+00
89	0.000E+00	0.000E+00	2.773E-04	-7.471E-11	1.326E-03	0.000E+00
90	0.000E+00	0.000E+00	1.684E-04	-3.933E-03	4.041E-03	0.000E+00
91	0.000E+00	0.000E+00	2.034E-04	-3.395E-03	3.737E-03	0.000E+00
92	0.000E+00	0.000E+00	2.333E-04	-2.889E-03	2.889E-03	0.000E+00
93	0.000E+00	0.000E+00	2.533E-04	-2.551E-03	1.566E-03	0.000E+00
94	0.000E+00	0.000E+00	2.034E-04	-3.737E-03	3.395E-03	0.000E+00
95	0.000E+00	0.000E+00	1.684E-04	-4.041E-03	3.933E-03	0.000E+00
96	0.000E+00	0.000E+00	1.269E-04	-4.808E-03	5.293E-03	0.000E+00
97	0.000E+00	0.000E+00	7.989E-05	-5.156E-03	5.156E-03	0.000E+00
98	0.000E+00	0.000E+00	1.269E-04	-5.293E-03	4.808E-03	0.000E+00
99	0.000E+00	0.000E+00	1.684E-04	-4.400E-03	4.400E-03	0.000E+00
100	0.000E+00	0.000E+00	2.269E-04	-3.322E-03	1.812E-03	0.000E+00
101	0.000E+00	0.000E+00	1.957E-04	-3.608E-03	2.122E-03	0.000E+00
102	0.000E+00	0.000E+00	1.957E-04	-2.122E-03	3.608E-03	0.000E+00
103	0.000E+00	0.000E+00	2.269E-04	-1.812E-03	3.322E-03	0.000E+00
104	0.000E+00	0.000E+00	2.533E-04	-1.566E-03	2.551E-03	0.000E+00
105	0.000E+00	0.000E+00	2.710E-04	-1.393E-03	1.393E-03	0.000E+00
106	0.000E+00	0.000E+00	2.269E-04	1.812E-03	3.322E-03	0.000E+00
107	0.000E+00	0.000E+00	2.034E-04	3.395E-03	3.737E-03	0.000E+00
108	0.000E+00	0.000E+00	1.684E-04	4.400E-03	4.400E-03	0.000E+00
109	0.000E+00	0.000E+00	1.269E-04	4.808E-03	5.293E-03	0.000E+00
110	0.000E+00	0.000E+00	2.034E-04	3.737E-03	3.395E-03	0.000E+00
111	0.000E+00	0.000E+00	2.269E-04	3.322E-03	1.812E-03	0.000E+00
112	0.000E+00	0.000E+00	2.710E-04	1.393E-03	1.393E-03	0.000E+00
113	0.000E+00	0.000E+00	2.533E-04	1.566E-03	2.551E-03	0.000E+00
114	0.000E+00	0.000E+00	2.333E-04	2.889E-03	2.889E-03	0.000E+00
115	0.000E+00	0.000E+00	2.533E-04	2.551E-03	1.566E-03	0.000E+00
116	0.000E+00	0.000E+00	1.684E-04	4.041E-03	3.933E-03	0.000E+00
117	0.000E+00	0.000E+00	1.957E-04	3.608E-03	2.122E-03	0.000E+00
118	0.000E+00	0.000E+00	1.957E-04	2.122E-03	3.608E-03	0.000E+00
119	0.000E+00	0.000E+00	1.684E-04	3.933E-03	4.041E-03	0.000E+00
120	0.000E+00	0.000E+00	1.269E-04	5.293E-03	4.808E-03	0.000E+00
121	0.000E+00	0.000E+00	7.989E-05	5.156E-03	5.156E-03	0.000E+00

	1	1	45	40	13	1
Maximum	0.000E+00	0.000E+00	2.833E-04	6.457E-03	6.457E-03	
0.000E+00						

	1	1	1	32	5	1
Minimum	0.000E+00	0.000E+00	0.000E+00	-6.457E-03	-6.457E-03	
0.000E+00						

Average	0.000E+00	0.000E+00	1.702E-04	-1.155E-11	1.578E-10	
0.000E+00						



## CASE 4

SDRC I-DEAS VI: FE\_Modeling\_&\_Analysis  
 93 21:30:48  
 n90

01-NOV-

Group ID : No stored PERMANENT GROUP  
 Analysis Dataset : 2 - CASE 1,LOAD 1,STRESSES  
 Report Type : Contour Units : MG  
 Dataset Type : Stress Load Set : 1  
 Frame of Reference: Global Data Component:  
 Max Prin  
 Surface Type : Top

Node	Max Prin	Mid Prin	Min Prin	Max Shear	Von Mises
1	-5.689E+04	0.000E+00	-2.428E+05	9.296E+04	2.199E+05
2	-5.689E+04	0.000E+00	-2.428E+05	9.296E+04	2.199E+05
3	-5.689E+04	0.000E+00	-2.428E+05	9.296E+04	2.199E+05
4	-5.689E+04	0.000E+00	-2.428E+05	9.296E+04	2.199E+05
5	7.637E+03	0.000E+00	-5.409E+04	3.086E+04	5.828E+04
6	2.356E+04	0.000E+00	-8.991E+03	1.627E+04	2.911E+04
7	3.616E+04	0.000E+00	2.026E+03	1.707E+04	3.519E+04
8	4.392E+04	0.000E+00	3.744E+03	2.009E+04	4.218E+04
9	4.597E+04	0.000E+00	5.180E+03	2.040E+04	4.361E+04
10	4.392E+04	0.000E+00	3.744E+03	2.009E+04	4.218E+04
11	3.616E+04	0.000E+00	2.026E+03	1.707E+04	3.519E+04
12	2.356E+04	0.000E+00	-8.991E+03	1.627E+04	2.911E+04
13	7.637E+03	0.000E+00	-5.409E+04	3.086E+04	5.828E+04
14	7.637E+03	0.000E+00	-5.409E+04	3.086E+04	5.828E+04
15	2.356E+04	0.000E+00	-8.991E+03	1.627E+04	2.911E+04
16	3.616E+04	0.000E+00	2.026E+03	1.707E+04	3.519E+04
17	4.392E+04	0.000E+00	3.744E+03	2.009E+04	4.218E+04
18	4.597E+04	0.000E+00	5.180E+03	2.040E+04	4.361E+04
19	4.392E+04	0.000E+00	3.744E+03	2.009E+04	4.218E+04
20	3.616E+04	0.000E+00	2.026E+03	1.707E+04	3.519E+04
21	2.356E+04	0.000E+00	-8.991E+03	1.627E+04	2.911E+04
22	7.637E+03	0.000E+00	-5.409E+04	3.086E+04	5.828E+04
23	7.637E+03	0.000E+00	-5.409E+04	3.086E+04	5.828E+04
24	2.356E+04	0.000E+00	-8.991E+03	1.627E+04	2.911E+04
25	3.616E+04	0.000E+00	2.026E+03	1.707E+04	3.519E+04
26	4.392E+04	0.000E+00	3.744E+03	2.009E+04	4.218E+04
27	4.597E+04	0.000E+00	5.180E+03	2.040E+04	4.361E+04
28	4.392E+04	0.000E+00	3.744E+03	2.009E+04	4.218E+04
29	3.616E+04	0.000E+00	2.026E+03	1.707E+04	3.519E+04

31	7.637E+03	0.000E+00	-5.409E+04	3.086E+04	5.828E+04
32	7.637E+03	0.000E+00	-5.409E+04	3.086E+04	5.828E+04
33	2.356E+04	0.000E+00	-8.991E+03	1.627E+04	2.911E+04
34	3.616E+04	0.000E+00	2.026E+03	1.707E+04	3.519E+04
35	4.392E+04	0.000E+00	3.744E+03	2.009E+04	4.218E+04
36	4.597E+04	0.000E+00	5.180E+03	2.040E+04	4.361E+04
37	4.392E+04	0.000E+00	3.744E+03	2.009E+04	4.218E+04
38	3.616E+04	0.000E+00	2.026E+03	1.707E+04	3.519E+04
39	2.356E+04	0.000E+00	-8.991E+03	1.627E+04	2.911E+04
40	7.637E+03	0.000E+00	-5.409E+04	3.086E+04	5.828E+04
41	4.072E+04	0.000E+00	8.693E+03	1.602E+04	3.715E+04
42	3.676E+04	0.000E+00	1.683E+04	9.962E+03	3.187E+04
43	3.377E+04	0.000E+00	2.409E+04	4.837E+03	3.012E+04
44	3.165E+04	0.000E+00	2.907E+04	1.291E+03	3.044E+04
45	3.076E+04	0.000E+00	3.076E+04	6.784E-08	3.076E+04
46	3.165E+04	0.000E+00	2.907E+04	1.291E+03	3.044E+04
47	3.377E+04	0.000E+00	2.409E+04	4.837E+03	3.012E+04
48	3.676E+04	0.000E+00	1.683E+04	9.962E+03	3.187E+04
49	4.072E+04	0.000E+00	8.693E+03	1.602E+04	3.715E+04
50	3.165E+04	0.000E+00	2.907E+04	1.291E+03	3.044E+04
51	3.377E+04	0.000E+00	2.409E+04	4.837E+03	3.012E+04
52	3.676E+04	0.000E+00	1.683E+04	9.962E+03	3.187E+04
53	4.072E+04	0.000E+00	8.693E+03	1.602E+04	3.715E+04
54	3.284E+04	0.000E+00	2.306E+04	4.887E+03	2.920E+04
55	3.158E+04	0.000E+00	1.879E+04	6.397E+03	2.752E+04
56	3.141E+04	0.000E+00	1.199E+04	9.708E+03	2.745E+04
57	3.405E+04	0.000E+00	4.987E+03	1.453E+04	3.185E+04
58	2.818E+04	0.000E+00	4.598E+03	1.179E+04	2.619E+04
59	1.873E+04	0.000E+00	-3.223E+03	1.097E+04	2.053E+04
60	3.405E+04	0.000E+00	4.987E+03	1.453E+04	3.185E+04
61	3.851E+04	0.000E+00	7.515E+03	1.550E+04	3.536E+04
62	3.564E+04	0.000E+00	1.602E+04	9.807E+03	3.092E+04
63	3.141E+04	0.000E+00	1.199E+04	9.708E+03	2.745E+04
64	1.873E+04	0.000E+00	-3.223E+03	1.097E+04	2.053E+04
65	2.226E+04	0.000E+00	-2.727E+03	1.249E+04	2.374E+04
66	3.142E+04	0.000E+00	2.778E+04	1.820E+03	2.977E+04
67	3.284E+04	0.000E+00	2.306E+04	4.887E+03	2.920E+04
68	3.564E+04	0.000E+00	1.602E+04	9.807E+03	3.092E+04
69	3.851E+04	0.000E+00	7.515E+03	1.550E+04	3.536E+04
70	3.284E+04	0.000E+00	2.306E+04	4.887E+03	2.920E+04
71	3.158E+04	0.000E+00	1.879E+04	6.397E+03	2.752E+04
72	3.141E+04	0.000E+00	1.199E+04	9.708E+03	2.745E+04
73	3.405E+04	0.000E+00	4.987E+03	1.453E+04	3.185E+04
74	2.818E+04	0.000E+00	4.598E+03	1.179E+04	2.619E+04
75	1.873E+04	0.000E+00	-3.223E+03	1.097E+04	2.053E+04
76	3.405E+04	0.000E+00	4.987E+03	1.453E+04	3.185E+04

	9	1	45	1	1
Maximum	4.597E+04	0.000E+00	3.076E+04	9.296E+04	2.199E+05
	1	1	1	45	96
Minimum	-5.689E+04	0.000E+00	-2.428E+05	6.784E-08	2.053E+04
Average	2.836E+04	0.000E+00	-3.197E+03	1.578E+04	3.928E+04

## CASE 5

SDRC I-DEAS VI: FE\_Modeling\_&\_Analysis 02-NOV-  
 93 12:57:58  
 Group ID : No stored PERMANENT GROUP  
 Analysis Dataset : 5 - CASE 3,LOAD 1,DISPLACEMENTS  
 Report Type : Contour Units : MG  
 Dataset Type : Displacements Load Set : 1  
 Frame of Reference: Global Data Component:  
 Magnitude

Node	Displ-X	Displ-Y	Displ-Z	Rot-X	Rot-Y	Rot-Z
1	0.000E+00	0.000E+00	8.929E-03	-2.869E-02	2.869E-02	0.000E+00
2	0.000E+00	0.000E+00	0.000E+00	0.000E+00	0.000E+00	0.000E+00
3	0.000E+00	0.000E+00	8.929E-03	2.869E-02	-2.869E-02	0.000E+00
4	0.000E+00	0.000E+00	0.000E+00	0.000E+00	0.000E+00	0.000E+00
5	0.000E+00	0.000E+00	8.476E-03	-2.531E-02	3.167E-02	0.000E+00
6	0.000E+00	0.000E+00	7.944E-03	-1.933E-02	3.935E-02	0.000E+00
7	0.000E+00	0.000E+00	7.280E-03	-1.068E-02	4.918E-02	0.000E+00
8	0.000E+00	0.000E+00	6.460E-03	4.043E-05	6.005E-02	0.000E+00
9	0.000E+00	0.000E+00	5.479E-03	1.268E-02	7.079E-02	0.000E+00
10	0.000E+00	0.000E+00	4.349E-03	2.648E-02	7.994E-02	0.000E+00
11	0.000E+00	0.000E+00	3.102E-03	4.175E-02	8.624E-02	0.000E+00
12	0.000E+00	0.000E+00	1.816E-03	5.367E-02	8.531E-02	0.000E+00
13	0.000E+00	0.000E+00	5.879E-04	7.311E-02	7.838E-02	0.000E+00
14	0.000E+00	0.000E+00	5.879E-04	7.838E-02	7.311E-02	0.000E+00
15	0.000E+00	0.000E+00	1.816E-03	8.531E-02	5.367E-02	0.000E+00
16	0.000E+00	0.000E+00	3.102E-03	8.624E-02	4.175E-02	0.000E+00
17	0.000E+00	0.000E+00	4.349E-03	7.994E-02	2.648E-02	0.000E+00
18	0.000E+00	0.000E+00	5.479E-03	7.079E-02	1.268E-02	0.000E+00
19	0.000E+00	0.000E+00	6.460E-03	6.005E-02	4.043E-05	0.000E+00
20	0.000E+00	0.000E+00	7.280E-03	4.918E-02	-1.068E-02	0.000E+00
21	0.000E+00	0.000E+00	7.944E-03	3.935E-02	-1.933E-02	0.000E+00
22	0.000E+00	0.000E+00	8.476E-03	3.167E-02	-2.531E-02	0.000E+00
23	0.000E+00	0.000E+00	8.476E-03	2.531E-02	-3.167E-02	0.000E+00
24	0.000E+00	0.000E+00	7.944E-03	1.933E-02	-3.935E-02	0.000E+00
25	0.000E+00	0.000E+00	7.280E-03	1.068E-02	-4.918E-02	0.000E+00
26	0.000E+00	0.000E+00	6.460E-03	-4.043E-05	-6.005E-02	0.000E+00
27	0.000E+00	0.000E+00	5.479E-03	-1.268E-02	-7.079E-02	0.000E+00
28	0.000E+00	0.000E+00	4.349E-03	-2.648E-02	-7.994E-02	0.000E+00
29	0.000E+00	0.000E+00	3.102E-03	-4.175E-02	-8.624E-02	0.000E+00
30	0.000E+00	0.000E+00	1.816E-03	-5.367E-02	-8.531E-02	0.000E+00
31	0.000E+00	0.000E+00	5.879E-04	-7.311E-02	-7.838E-02	0.000E+00
32	0.000E+00	0.000E+00	5.879E-04	-7.838E-02	-7.311E-02	0.000E+00
33	0.000E+00	0.000E+00	1.816E-03	-8.531E-02	-5.367E-02	0.000E+00
34	0.000E+00	0.000E+00	3.102E-03	-8.624E-02	-4.175E-02	0.000E+00

35	0.000E+00	0.000E+00	4.349E-03	-7.994E-02	-2.648E-02	0.000E+00
36	0.000E+00	0.000E+00	5.479E-03	-7.079E-02	-1.268E-02	0.000E+00
37	0.000E+00	0.000E+00	6.460E-03	-6.005E-02	-4.043E-05	0.000E+00
38	0.000E+00	0.000E+00	7.280E-03	-4.918E-02	1.068E-02	0.000E+00
39	0.000E+00	0.000E+00	7.944E-03	-3.935E-02	1.933E-02	0.000E+00
40	0.000E+00	0.000E+00	8.476E-03	-3.167E-02	2.531E-02	0.000E+00
41	0.000E+00	0.000E+00	5.677E-03	-1.372E-02	-5.734E-02	0.000E+00
42	0.000E+00	0.000E+00	5.876E-03	-1.281E-02	-4.376E-02	0.000E+00
43	0.000E+00	0.000E+00	6.047E-03	-9.949E-03	-2.955E-02	0.000E+00
44	0.000E+00	0.000E+00	6.162E-03	-5.422E-03	-1.493E-02	0.000E+00
45	0.000E+00	0.000E+00	6.203E-03	1.736E-11	-1.735E-11	0.000E+00
46	0.000E+00	0.000E+00	6.162E-03	5.422E-03	1.493E-02	0.000E+00
47	0.000E+00	0.000E+00	6.047E-03	9.949E-03	2.955E-02	0.000E+00
48	0.000E+00	0.000E+00	5.876E-03	1.281E-02	4.376E-02	0.000E+00
49	0.000E+00	0.000E+00	5.677E-03	1.372E-02	5.734E-02	0.000E+00
50	0.000E+00	0.000E+00	6.162E-03	-1.493E-02	-5.422E-03	0.000E+00
51	0.000E+00	0.000E+00	6.047E-03	-2.955E-02	-9.949E-03	0.000E+00
52	0.000E+00	0.000E+00	5.876E-03	-4.376E-02	-1.281E-02	0.000E+00
53	0.000E+00	0.000E+00	5.677E-03	-5.734E-02	-1.372E-02	0.000E+00
54	0.000E+00	0.000E+00	5.556E-03	-2.477E-02	-3.583E-02	0.000E+00
55	0.000E+00	0.000E+00	4.984E-03	-4.045E-02	-4.045E-02	0.000E+00
56	0.000E+00	0.000E+00	4.363E-03	-5.633E-02	-4.237E-02	0.000E+00
57	0.000E+00	0.000E+00	3.730E-03	-7.101E-02	-4.200E-02	0.000E+00
58	0.000E+00	0.000E+00	3.507E-03	-5.788E-02	-5.788E-02	0.000E+00
59	0.000E+00	0.000E+00	2.645E-03	-5.696E-02	-7.367E-02	0.000E+00
60	0.000E+00	0.000E+00	5.167E-03	-2.719E-02	-5.082E-02	0.000E+00
61	0.000E+00	0.000E+00	4.363E-03	-4.237E-02	-5.633E-02	0.000E+00
62	0.000E+00	0.000E+00	3.730E-03	-4.200E-02	-7.101E-02	0.000E+00
63	0.000E+00	0.000E+00	4.755E-03	-2.771E-02	-6.561E-02	0.000E+00
64	0.000E+00	0.000E+00	2.645E-03	-7.367E-02	-5.696E-02	0.000E+00
65	0.000E+00	0.000E+00	1.615E-03	-6.377E-02	-6.377E-02	0.000E+00
66	0.000E+00	0.000E+00	5.896E-03	-2.052E-02	-2.052E-02	0.000E+00
67	0.000E+00	0.000E+00	5.556E-03	-3.583E-02	-2.477E-02	0.000E+00
68	0.000E+00	0.000E+00	5.167E-03	-5.082E-02	-2.719E-02	0.000E+00
69	0.000E+00	0.000E+00	4.755E-03	-6.561E-02	-2.771E-02	0.000E+00
70	0.000E+00	0.000E+00	6.440E-03	-2.291E-02	4.003E-03	0.000E+00
71	0.000E+00	0.000E+00	6.738E-03	-1.682E-02	1.682E-02	0.000E+00
72	0.000E+00	0.000E+00	6.957E-03	-1.230E-02	2.852E-02	0.000E+00
73	0.000E+00	0.000E+00	7.124E-03	-1.006E-02	3.919E-02	0.000E+00
74	0.000E+00	0.000E+00	7.340E-03	-2.261E-02	2.261E-02	0.000E+00
75	0.000E+00	0.000E+00	7.654E-03	-3.148E-02	1.928E-02	0.000E+00
76	0.000E+00	0.000E+00	6.473E-03	-3.589E-02	4.280E-04	0.000E+00
77	0.000E+00	0.000E+00	6.957E-03	-2.852E-02	1.230E-02	0.000E+00
78	0.000E+00	0.000E+00	7.124E-03	-3.919E-02	1.006E-02	0.000E+00
79	0.000E+00	0.000E+00	6.469E-03	-4.821E-02	-1.059E-03	0.000E+00
80	0.000E+00	0.000E+00	7.654E-03	-1.928E-02	3.148E-02	0.000E+00
81	0.000E+00	0.000E+00	8.088E-03	-2.642E-02	2.642E-02	0.000E+00
82	0.000E+00	0.000E+00	6.342E-03	-9.077E-03	9.077E-03	0.000E+00
83	0.000E+00	0.000E+00	6.440E-03	-4.003E-03	2.291E-02	0.000E+00
84	0.000E+00	0.000E+00	6.473E-03	-4.280E-04	3.589E-02	0.000E+00

85	0.000E+00	0.000E+00	6.469E-03	1.059E-03	4.821E-02	0.000E+00
86	0.000E+00	0.000E+00	5.677E-03	5.734E-02	1.372E-02	0.000E+00
87	0.000E+00	0.000E+00	5.876E-03	4.376E-02	1.281E-02	0.000E+00
88	0.000E+00	0.000E+00	6.047E-03	2.955E-02	9.949E-03	0.000E+00
89	0.000E+00	0.000E+00	6.162E-03	1.493E-02	5.422E-03	0.000E+00
90	0.000E+00	0.000E+00	7.124E-03	3.919E-02	-1.006E-02	0.000E+00
91	0.000E+00	0.000E+00	6.957E-03	2.852E-02	-1.230E-02	0.000E+00
92	0.000E+00	0.000E+00	6.738E-03	1.682E-02	-1.682E-02	0.000E+00
93	0.000E+00	0.000E+00	6.440E-03	4.003E-03	-2.291E-02	0.000E+00
94	0.000E+00	0.000E+00	6.957E-03	1.230E-02	-2.852E-02	0.000E+00
95	0.000E+00	0.000E+00	7.124E-03	1.006E-02	-3.919E-02	0.000E+00
96	0.000E+00	0.000E+00	7.654E-03	1.928E-02	-3.148E-02	0.000E+00
97	0.000E+00	0.000E+00	8.088E-03	2.642E-02	-2.642E-02	0.000E+00
98	0.000E+00	0.000E+00	7.654E-03	3.148E-02	-1.928E-02	0.000E+00
99	0.000E+00	0.000E+00	7.340E-03	2.261E-02	-2.261E-02	0.000E+00
100	0.000E+00	0.000E+00	6.473E-03	4.280E-04	-3.589E-02	0.000E+00
101	0.000E+00	0.000E+00	6.469E-03	-1.059E-03	-4.821E-02	0.000E+00
102	0.000E+00	0.000E+00	6.469E-03	4.821E-02	1.059E-03	0.000E+00
103	0.000E+00	0.000E+00	6.473E-03	3.589E-02	-4.280E-04	0.000E+00
104	0.000E+00	0.000E+00	6.440E-03	2.291E-02	-4.003E-03	0.000E+00
105	0.000E+00	0.000E+00	6.342E-03	9.077E-03	-9.077E-03	0.000E+00
106	0.000E+00	0.000E+00	5.167E-03	5.082E-02	2.719E-02	0.000E+00
107	0.000E+00	0.000E+00	4.363E-03	5.633E-02	4.237E-02	0.000E+00
108	0.000E+00	0.000E+00	3.507E-03	5.788E-02	5.788E-02	0.000E+00
109	0.000E+00	0.000E+00	2.645E-03	5.696E-02	7.367E-02	0.000E+00
110	0.000E+00	0.000E+00	4.363E-03	4.237E-02	5.633E-02	0.000E+00
111	0.000E+00	0.000E+00	5.167E-03	2.719E-02	5.082E-02	0.000E+00
112	0.000E+00	0.000E+00	5.556E-03	2.477E-02	3.583E-02	0.000E+00
113	0.000E+00	0.000E+00	5.896E-03	2.052E-02	2.052E-02	0.000E+00
114	0.000E+00	0.000E+00	5.556E-03	3.583E-02	2.477E-02	0.000E+00
115	0.000E+00	0.000E+00	4.984E-03	4.045E-02	4.045E-02	0.000E+00
116	0.000E+00	0.000E+00	3.730E-03	4.200E-02	7.101E-02	0.000E+00
117	0.000E+00	0.000E+00	4.755E-03	2.771E-02	6.561E-02	0.000E+00
118	0.000E+00	0.000E+00	4.755E-03	6.561E-02	2.771E-02	0.000E+00
119	0.000E+00	0.000E+00	3.730E-03	7.101E-02	4.200E-02	0.000E+00
120	0.000E+00	0.000E+00	2.645E-03	7.367E-02	5.696E-02	0.000E+00
121	0.000E+00	0.000E+00	1.615E-03	6.377E-02	6.377E-02	0.000E+00

	1	1	1	16	11	1
Maximum	0.000E+00	0.000E+00	8.929E-03	8.624E-02	8.624E-02	
0.000E+00						

	1	1	2	34	29	1
Minimum	0.000E+00	0.000E+00	0.000E+00	-8.624E-02	-8.624E-02	
0.000E+00						

Average	0.000E+00	0.000E+00	5.450E-03	1.170E-09	-1.416E-09	
0.000E+00						

Missing Page

## APPENDIX TABLE 6

CASE 6

SDRC I-DEAS VI: FE\_Modeling\_&\_Analysis  
93 12:57:15

02-NOV-

none

Group ID : No stored PERMANENT GROUP  
 Analysis Dataset : 6 - CASE 3,LOAD 1,STRESSES  
 Report Type : Contour Units : MG  
 Dataset Type : Stress Load Set : 1  
 Frame of Reference: Global Data Component:  
 Max Prin  
 Surface Type : Top

Node	Max Prin	Mid Prin	Min Prin	Max Shear	Von Mises
1	7.212E+04	0.000E+00	1.078E+04	3.067E+04	6.738E+04
2	-4.267E+05	0.000E+00	-1.756E+06	6.646E+05	1.586E+06
3	7.212E+04	0.000E+00	1.078E+04	3.067E+04	6.738E+04
4	-4.267E+05	0.000E+00	-1.756E+06	6.646E+05	1.586E+06
5	9.386E+04	0.000E+00	-4.233E+03	4.905E+04	9.605E+04
6	1.404E+05	0.000E+00	-1.918E+04	7.981E+04	1.509E+05
7	1.701E+05	0.000E+00	-3.472E+04	1.024E+05	1.898E+05
8	1.878E+05	0.000E+00	-5.152E+04	1.197E+05	2.182E+05
9	1.931E+05	0.000E+00	-6.909E+04	1.311E+05	2.354E+05
10	1.826E+05	0.000E+00	-9.219E+04	1.374E+05	2.422E+05
11	1.487E+05	0.000E+00	-1.147E+05	1.317E+05	2.288E+05
12	7.399E+04	0.000E+00	-1.744E+05	1.242E+05	2.209E+05
13	1.088E+04	0.000E+00	-4.747E+05	2.428E+05	4.802E+05
14	1.088E+04	0.000E+00	-4.747E+05	2.428E+05	4.802E+05
15	7.399E+04	0.000E+00	-1.744E+05	1.242E+05	2.209E+05
16	1.487E+05	0.000E+00	-1.147E+05	1.317E+05	2.288E+05
17	1.826E+05	0.000E+00	-9.219E+04	1.374E+05	2.422E+05
18	1.931E+05	0.000E+00	-6.909E+04	1.311E+05	2.354E+05
19	1.878E+05	0.000E+00	-5.152E+04	1.197E+05	2.182E+05
20	1.701E+05	0.000E+00	-3.472E+04	1.024E+05	1.898E+05
21	1.404E+05	0.000E+00	-1.918E+04	7.981E+04	1.509E+05
22	9.386E+04	0.000E+00	-4.233E+03	4.905E+04	9.605E+04
23	9.386E+04	0.000E+00	-4.233E+03	4.905E+04	9.605E+04
24	1.404E+05	0.000E+00	-1.918E+04	7.981E+04	1.509E+05
25	1.701E+05	0.000E+00	-3.472E+04	1.024E+05	1.898E+05
26	1.878E+05	0.000E+00	-5.152E+04	1.197E+05	2.182E+05
27	1.931E+05	0.000E+00	-6.909E+04	1.311E+05	2.354E+05
28	1.826E+05	0.000E+00	-9.219E+04	1.374E+05	2.422E+05
29	1.487E+05	0.000E+00	-1.147E+05	1.317E+05	2.288E+05
30	7.399E+04	0.000E+00	-1.744E+05	1.242E+05	2.209E+05



31	1.088E+04	0.000E+00	-4.747E+05	2.428E+05	4.802E+05
32	1.088E+04	0.000E+00	-4.747E+05	2.428E+05	4.802E+05
33	7.399E+04	0.000E+00	-1.744E+05	1.242E+05	2.209E+05
34	1.487E+05	0.000E+00	-1.147E+05	1.317E+05	2.288E+05
35	1.826E+05	0.000E+00	-9.219E+04	1.374E+05	2.422E+05
36	1.931E+05	0.000E+00	-6.909E+04	1.311E+05	2.354E+05
37	1.878E+05	0.000E+00	-5.152E+04	1.197E+05	2.182E+05
38	1.701E+05	0.000E+00	-3.472E+04	1.024E+05	1.898E+05
39	1.404E+05	0.000E+00	-1.918E+04	7.981E+04	1.509E+05
40	9.386E+04	0.000E+00	-4.233E+03	4.905E+04	9.605E+04
41	1.885E+05	0.000E+00	-6.824E+04	1.283E+05	2.303E+05
42	1.936E+05	0.000E+00	-6.338E+04	1.285E+05	2.318E+05
43	2.022E+05	0.000E+00	-6.082E+04	1.315E+05	2.385E+05
44	2.090E+05	0.000E+00	-6.000E+04	1.345E+05	2.445E+05
45	2.112E+05	0.000E+00	-6.023E+04	1.357E+05	2.469E+05
46	2.090E+05	0.000E+00	-6.000E+04	1.345E+05	2.445E+05
47	2.022E+05	0.000E+00	-6.082E+04	1.315E+05	2.385E+05
48	1.936E+05	0.000E+00	-6.338E+04	1.285E+05	2.318E+05
49	1.885E+05	0.000E+00	-6.824E+04	1.283E+05	2.303E+05
50	2.090E+05	0.000E+00	-6.000E+04	1.345E+05	2.445E+05
51	2.022E+05	0.000E+00	-6.082E+04	1.315E+05	2.385E+05
52	1.936E+05	0.000E+00	-6.338E+04	1.285E+05	2.318E+05
53	1.885E+05	0.000E+00	-6.824E+04	1.283E+05	2.303E+05
54	1.997E+05	0.000E+00	-7.736E+04	1.385E+05	2.476E+05
55	1.890E+05	0.000E+00	-9.791E+04	1.434E+05	2.526E+05
56	1.697E+05	0.000E+00	-1.098E+05	1.397E+05	2.439E+05
57	1.618E+05	0.000E+00	-1.100E+05	1.359E+05	2.368E+05
58	1.467E+05	0.000E+00	-1.379E+05	1.423E+05	2.465E+05
59	7.221E+04	0.000E+00	-1.519E+05	1.120E+05	1.981E+05
60	1.906E+05	0.000E+00	-8.264E+04	1.366E+05	2.427E+05
61	1.697E+05	0.000E+00	-1.098E+05	1.397E+05	2.439E+05
62	1.618E+05	0.000E+00	-1.100E+05	1.359E+05	2.368E+05
63	1.796E+05	0.000E+00	-8.939E+04	1.345E+05	2.372E+05
64	7.221E+04	0.000E+00	-1.519E+05	1.120E+05	1.981E+05
65	9.347E+04	0.000E+00	-1.012E+05	9.736E+04	1.687E+05
66	2.067E+05	0.000E+00	-6.971E+04	1.382E+05	2.490E+05
67	1.997E+05	0.000E+00	-7.736E+04	1.385E+05	2.476E+05
68	1.906E+05	0.000E+00	-8.264E+04	1.366E+05	2.427E+05
69	1.796E+05	0.000E+00	-8.939E+04	1.345E+05	2.372E+05
70	1.966E+05	0.000E+00	-4.770E+04	1.221E+05	2.242E+05
71	1.853E+05	0.000E+00	-3.754E+04	1.114E+05	2.067E+05
72	1.721E+05	0.000E+00	-3.259E+04	1.023E+05	1.905E+05
73	1.631E+05	0.000E+00	-3.548E+04	9.931E+04	1.835E+05
74	1.515E+05	0.000E+00	-2.289E+04	8.722E+04	1.642E+05
75	1.342E+05	0.000E+00	-2.236E+04	7.826E+04	1.466E+05
76	1.875E+05	0.000E+00	-4.619E+04	1.169E+05	2.144E+05

77	1.721E+05	0.000E+00	-3.259E+04	1.023E+05	1.905E+05
78	1.631E+05	0.000E+00	-3.548E+04	9.931E+04	1.835E+05
79	1.809E+05	0.000E+00	-5.129E+04	1.161E+05	2.113E+05
80	1.342E+05	0.000E+00	-2.236E+04	7.826E+04	1.466E+05
81	9.925E+04	0.000E+00	-1.335E+04	5.630E+04	1.066E+05
82	2.049E+05	0.000E+00	-5.270E+04	1.288E+05	2.357E+05
83	1.966E+05	0.000E+00	-4.770E+04	1.221E+05	2.242E+05
84	1.875E+05	0.000E+00	-4.619E+04	1.169E+05	2.144E+05
85	1.809E+05	0.000E+00	-5.129E+04	1.161E+05	2.113E+05
86	1.885E+05	0.000E+00	-6.824E+04	1.283E+05	2.303E+05
87	1.936E+05	0.000E+00	-6.338E+04	1.285E+05	2.318E+05
88	2.022E+05	0.000E+00	-6.082E+04	1.315E+05	2.385E+05
89	2.090E+05	0.000E+00	-6.000E+04	1.345E+05	2.445E+05
90	1.631E+05	0.000E+00	-3.548E+04	9.931E+04	1.835E+05
91	1.721E+05	0.000E+00	-3.259E+04	1.023E+05	1.905E+05
92	1.853E+05	0.000E+00	-3.754E+04	1.114E+05	2.067E+05
93	1.966E+05	0.000E+00	-4.770E+04	1.221E+05	2.242E+05
94	1.721E+05	0.000E+00	-3.259E+04	1.023E+05	1.905E+05
95	1.631E+05	0.000E+00	-3.548E+04	9.931E+04	1.835E+05
96	1.342E+05	0.000E+00	-2.236E+04	7.826E+04	1.466E+05
97	9.925E+04	0.000E+00	-1.335E+04	5.630E+04	1.066E+05
98	1.342E+05	0.000E+00	-2.236E+04	7.826E+04	1.466E+05
99	1.515E+05	0.000E+00	-2.289E+04	8.722E+04	1.642E+05
100	1.875E+05	0.000E+00	-4.619E+04	1.169E+05	2.144E+05
101	1.809E+05	0.000E+00	-5.129E+04	1.161E+05	2.113E+05
102	1.809E+05	0.000E+00	-5.129E+04	1.161E+05	2.113E+05
103	1.875E+05	0.000E+00	-4.619E+04	1.169E+05	2.144E+05
104	1.966E+05	0.000E+00	-4.770E+04	1.221E+05	2.242E+05
105	2.049E+05	0.000E+00	-5.270E+04	1.288E+05	2.357E+05
106	1.906E+05	0.000E+00	-8.264E+04	1.366E+05	2.427E+05
107	1.697E+05	0.000E+00	-1.098E+05	1.397E+05	2.439E+05
108	1.467E+05	0.000E+00	-1.379E+05	1.423E+05	2.465E+05
109	7.221E+04	0.000E+00	-1.519E+05	1.120E+05	1.981E+05
110	1.697E+05	0.000E+00	-1.098E+05	1.397E+05	2.439E+05
111	1.906E+05	0.000E+00	-8.264E+04	1.366E+05	2.427E+05
112	1.997E+05	0.000E+00	-7.736E+04	1.385E+05	2.476E+05
113	2.067E+05	0.000E+00	-6.971E+04	1.382E+05	2.490E+05
114	1.997E+05	0.000E+00	-7.736E+04	1.385E+05	2.476E+05
115	1.890E+05	0.000E+00	-9.791E+04	1.434E+05	2.526E+05
116	1.618E+05	0.000E+00	-1.100E+05	1.359E+05	2.368E+05
117	1.796E+05	0.000E+00	-8.939E+04	1.345E+05	2.372E+05
118	1.796E+05	0.000E+00	-8.939E+04	1.345E+05	2.372E+05
119	1.618E+05	0.000E+00	-1.100E+05	1.359E+05	2.368E+05
120	7.221E+04	0.000E+00	-1.519E+05	1.120E+05	1.981E+05
121	9.347E+04	0.000E+00	-1.012E+05	9.736E+04	1.687E+05

	45	1	1	2	2
Maximum	2.112E+05	0.000E+00	1.078E+04	6.646E+05	1.586E+06
	2	1	2	1	1
Minimum	-4.267E+05	0.000E+00	-1.756E+06	3.067E+04	6.738E+04
Average	1.493E+05	0.000E+00	-1.090E+05	1.292E+05	2.409E+05

SDRC I-DEAS VI: FE\_Modeling\_&\_Analysis  
n92

02-NOV-93 17:10:59

Group ID : No stored PERMANENT GROUP  
 Analysis Dataset : 1 - CASE 1,LOAD 1,DISPLACEMENTS  
 Report Type : Contour Units : MG  
 Dataset Type : Displacements Load Set : 1  
 Frame of Reference: Global Data Component: Magnitude

Node	Displ-X	Displ-Y	Displ-Z	Rot-X	Rot-Y	Rot-Z
1	0.000E+00	0.000E+00	1.152E-03	-6.170E-03	6.170E-03	0.000E+00
2	0.000E+00	0.000E+00	0.000E+00	0.000E+00	0.000E+00	0.000E+00
3	0.000E+00	0.000E+00	1.152E-03	6.170E-03	-6.170E-03	0.000E+00
4	0.000E+00	0.000E+00	0.000E+00	0.000E+00	0.000E+00	0.000E+00
5	0.000E+00	0.000E+00	1.094E-03	-5.444E-03	6.809E-03	0.000E+00
6	0.000E+00	0.000E+00	1.025E-03	-4.157E-03	8.462E-03	0.000E+00
7	0.000E+00	0.000E+00	9.393E-04	-2.297E-03	1.058E-02	0.000E+00
8	0.000E+00	0.000E+00	8.336E-04	8.365E-06	1.291E-02	0.000E+00
9	0.000E+00	0.000E+00	7.070E-04	2.726E-03	1.522E-02	0.000E+00
10	0.000E+00	0.000E+00	5.611E-04	5.694E-03	1.719E-02	0.000E+00
11	0.000E+00	0.000E+00	4.003E-04	8.978E-03	1.854E-02	0.000E+00
12	0.000E+00	0.000E+00	2.343E-04	1.154E-02	1.834E-02	0.000E+00
13	0.000E+00	0.000E+00	7.589E-05	1.572E-02	1.685E-02	0.000E+00
14	0.000E+00	0.000E+00	7.589E-05	1.685E-02	1.572E-02	0.000E+00
15	0.000E+00	0.000E+00	2.343E-04	1.834E-02	1.154E-02	0.000E+00
16	0.000E+00	0.000E+00	4.003E-04	1.854E-02	8.978E-03	0.000E+00
17	0.000E+00	0.000E+00	5.611E-04	1.719E-02	5.694E-03	0.000E+00
18	0.000E+00	0.000E+00	7.070E-04	1.522E-02	2.726E-03	0.000E+00
19	0.000E+00	0.000E+00	8.336E-04	1.291E-02	8.367E-06	0.000E+00
20	0.000E+00	0.000E+00	9.393E-04	1.058E-02	-2.297E-03	0.000E+00
21	0.000E+00	0.000E+00	1.025E-03	8.462E-03	-4.157E-03	0.000E+00
22	0.000E+00	0.000E+00	1.094E-03	6.809E-03	-5.444E-03	0.000E+00
23	0.000E+00	0.000E+00	1.094E-03	5.444E-03	-6.809E-03	0.000E+00
24	0.000E+00	0.000E+00	1.025E-03	4.157E-03	-8.462E-03	0.000E+00
25	0.000E+00	0.000E+00	9.393E-04	2.297E-03	-1.058E-02	0.000E+00
26	0.000E+00	0.000E+00	8.336E-04	-8.367E-06	-1.291E-02	0.000E+00
27	0.000E+00	0.000E+00	7.070E-04	-2.726E-03	-1.522E-02	0.000E+00
28	0.000E+00	0.000E+00	5.611E-04	-5.694E-03	-1.719E-02	0.000E+00
29	0.000E+00	0.000E+00	4.003E-04	-8.978E-03	-1.854E-02	0.000E+00
30	0.000E+00	0.000E+00	2.343E-04	-1.154E-02	-1.834E-02	0.000E+00
31	0.000E+00	0.000E+00	7.589E-05	-1.572E-02	-1.685E-02	0.000E+00
32	0.000E+00	0.000E+00	7.589E-05	-1.685E-02	-1.572E-02	0.000E+00
33	0.000E+00	0.000E+00	2.343E-04	-1.834E-02	-1.154E-02	0.000E+00
34	0.000E+00	0.000E+00	4.003E-04	-1.854E-02	-8.978E-03	0.000E+00
35	0.000E+00	0.000E+00	5.611E-04	-1.719E-02	-5.694E-03	0.000E+00
36	0.000E+00	0.000E+00	7.070E-04	-1.522E-02	-2.726E-03	0.000E+00
37	0.000E+00	0.000E+00	8.336E-04	-1.291E-02	-8.365E-06	0.000E+00
38	0.000E+00	0.000E+00	9.393E-04	-1.058E-02	2.297E-03	0.000E+00
39	0.000E+00	0.000E+00	1.025E-03	-8.462E-03	4.157E-03	0.000E+00
40	0.000E+00	0.000E+00	1.094E-03	-6.809E-03	5.444E-03	0.000E+00
41	0.000E+00	0.000E+00	7.325E-04	-2.950E-03	-1.233E-02	0.000E+00
42	0.000E+00	0.000E+00	7.582E-04	-2.755E-03	-9.409E-03	0.000E+00
43	0.000E+00	0.000E+00	7.802E-04	-2.139E-03	-6.354E-03	0.000E+00
44	0.000E+00	0.000E+00	7.951E-04	-1.166E-03	-3.211E-03	0.000E+00
45	0.000E+00	0.000E+00	8.003E-04	-8.930E-10	8.932E-10	0.000E+00
46	0.000E+00	0.000E+00	7.951E-04	1.166E-03	3.211E-03	0.000E+00
47	0.000E+00	0.000E+00	7.802E-04	2.139E-03	6.354E-03	0.000E+00
48	0.000E+00	0.000E+00	7.582E-04	2.755E-03	9.409E-03	0.000E+00
49	0.000E+00	0.000E+00	7.325E-04	2.950E-03	1.233E-02	0.000E+00

Node	Displ-X	Displ-Y	Displ-Z	Rot-X	Rot-Y	Rot-Z
50	0.000E+00	0.000E+00	7.951E-04	-3.211E-03	-1.166E-03	0.000E+00
51	0.000E+00	0.000E+00	7.802E-04	-6.354E-03	-2.139E-03	0.000E+00
52	0.000E+00	0.000E+00	7.582E-04	-9.409E-03	-2.755E-03	0.000E+00
53	0.000E+00	0.000E+00	7.325E-04	-1.233E-02	-2.950E-03	0.000E+00
54	0.000E+00	0.000E+00	7.169E-04	-5.326E-03	-7.704E-03	0.000E+00
55	0.000E+00	0.000E+00	6.431E-04	-8.699E-03	-8.699E-03	0.000E+00
56	0.000E+00	0.000E+00	5.630E-04	-1.211E-02	-9.111E-03	0.000E+00
57	0.000E+00	0.000E+00	4.813E-04	-1.527E-02	-9.031E-03	0.000E+00
58	0.000E+00	0.000E+00	4.525E-04	-1.245E-02	-1.245E-02	0.000E+00
59	0.000E+00	0.000E+00	3.413E-04	-1.225E-02	-1.584E-02	0.000E+00
60	0.000E+00	0.000E+00	4.813E-04	-9.031E-03	-1.527E-02	0.000E+00
61	0.000E+00	0.000E+00	6.135E-04	-5.958E-03	-1.411E-02	0.000E+00
62	0.000E+00	0.000E+00	6.667E-04	-5.847E-03	-1.093E-02	0.000E+00
63	0.000E+00	0.000E+00	5.630E-04	-9.111E-03	-1.211E-02	0.000E+00
64	0.000E+00	0.000E+00	3.413E-04	-1.584E-02	-1.225E-02	0.000E+00
65	0.000E+00	0.000E+00	2.083E-04	-1.371E-02	-1.371E-02	0.000E+00
66	0.000E+00	0.000E+00	7.608E-04	-4.413E-03	-4.413E-03	0.000E+00
67	0.000E+00	0.000E+00	7.169E-04	-7.704E-03	-5.326E-03	0.000E+00
68	0.000E+00	0.000E+00	6.667E-04	-1.093E-02	-5.847E-03	0.000E+00
69	0.000E+00	0.000E+00	6.135E-04	-1.411E-02	-5.958E-03	0.000E+00
70	0.000E+00	0.000E+00	8.310E-04	-4.926E-03	8.610E-04	0.000E+00
71	0.000E+00	0.000E+00	8.694E-04	-3.617E-03	3.617E-03	0.000E+00
72	0.000E+00	0.000E+00	8.976E-04	-2.644E-03	6.133E-03	0.000E+00
73	0.000E+00	0.000E+00	9.192E-04	-2.163E-03	8.428E-03	0.000E+00
74	0.000E+00	0.000E+00	9.471E-04	-4.863E-03	4.863E-03	0.000E+00
75	0.000E+00	0.000E+00	9.876E-04	-6.771E-03	4.146E-03	0.000E+00
76	0.000E+00	0.000E+00	9.192E-04	-8.428E-03	2.163E-03	0.000E+00
77	0.000E+00	0.000E+00	8.347E-04	-1.037E-02	-2.274E-04	0.000E+00
78	0.000E+00	0.000E+00	8.353E-04	-7.718E-03	9.229E-05	0.000E+00
79	0.000E+00	0.000E+00	8.976E-04	-6.133E-03	2.644E-03	0.000E+00
80	0.000E+00	0.000E+00	9.876E-04	-4.146E-03	6.771E-03	0.000E+00
81	0.000E+00	0.000E+00	1.044E-03	-5.682E-03	5.682E-03	0.000E+00
82	0.000E+00	0.000E+00	8.183E-04	-1.952E-03	1.952E-03	0.000E+00
83	0.000E+00	0.000E+00	8.310E-04	-8.610E-04	4.926E-03	0.000E+00
84	0.000E+00	0.000E+00	8.353E-04	-9.229E-05	7.718E-03	0.000E+00
85	0.000E+00	0.000E+00	8.347E-04	2.274E-04	1.037E-02	0.000E+00
86	0.000E+00	0.000E+00	7.325E-04	1.233E-02	2.950E-03	0.000E+00
87	0.000E+00	0.000E+00	7.582E-04	9.409E-03	2.755E-03	0.000E+00
88	0.000E+00	0.000E+00	7.802E-04	6.354E-03	2.139E-03	0.000E+00
89	0.000E+00	0.000E+00	7.951E-04	3.211E-03	1.166E-03	0.000E+00
90	0.000E+00	0.000E+00	9.192E-04	8.428E-03	-2.163E-03	0.000E+00
91	0.000E+00	0.000E+00	8.976E-04	6.133E-03	-2.644E-03	0.000E+00
92	0.000E+00	0.000E+00	8.694E-04	3.617E-03	-3.617E-03	0.000E+00
93	0.000E+00	0.000E+00	8.310E-04	8.610E-04	-4.926E-03	0.000E+00
94	0.000E+00	0.000E+00	8.976E-04	2.644E-03	-6.133E-03	0.000E+00
95	0.000E+00	0.000E+00	9.192E-04	2.163E-03	-8.428E-03	0.000E+00
96	0.000E+00	0.000E+00	9.876E-04	4.146E-03	-6.771E-03	0.000E+00
97	0.000E+00	0.000E+00	1.044E-03	5.682E-03	-5.682E-03	0.000E+00
98	0.000E+00	0.000E+00	9.876E-04	6.771E-03	-4.146E-03	0.000E+00
99	0.000E+00	0.000E+00	9.471E-04	4.863E-03	-4.863E-03	0.000E+00
100	0.000E+00	0.000E+00	8.353E-04	9.229E-05	-7.718E-03	0.000E+00
101	0.000E+00	0.000E+00	8.347E-04	-2.274E-04	-1.037E-02	0.000E+00
102	0.000E+00	0.000E+00	8.347E-04	1.037E-02	2.274E-04	0.000E+00
103	0.000E+00	0.000E+00	8.353E-04	7.718E-03	-9.229E-05	0.000E+00
104	0.000E+00	0.000E+00	8.310E-04	4.926E-03	-8.610E-04	0.000E+00

Node	Displ-X	Displ-Y	Displ-Z	Rot-X	Rot-Y	Rot-Z
105	0.000E+00	0.000E+00	8.183E-04	1.952E-03	-1.952E-03	0.000E+00
106	0.000E+00	0.000E+00	6.667E-04	1.093E-02	5.847E-03	0.000E+00
107	0.000E+00	0.000E+00	5.630E-04	1.211E-02	9.111E-03	0.000E+00
108	0.000E+00	0.000E+00	4.525E-04	1.245E-02	1.245E-02	0.000E+00
109	0.000E+00	0.000E+00	3.413E-04	1.225E-02	1.584E-02	0.000E+00
110	0.000E+00	0.000E+00	5.630E-04	9.111E-03	1.211E-02	0.000E+00
111	0.000E+00	0.000E+00	6.667E-04	5.847E-03	1.093E-02	0.000E+00
112	0.000E+00	0.000E+00	7.608E-04	4.413E-03	4.413E-03	0.000E+00
113	0.000E+00	0.000E+00	7.169E-04	7.704E-03	5.326E-03	0.000E+00
114	0.000E+00	0.000E+00	6.431E-04	8.699E-03	8.699E-03	0.000E+00
115	0.000E+00	0.000E+00	7.169E-04	5.326E-03	7.704E-03	0.000E+00
116	0.000E+00	0.000E+00	4.813E-04	9.031E-03	1.527E-02	0.000E+00
117	0.000E+00	0.000E+00	6.135E-04	5.958E-03	1.411E-02	0.000E+00
118	0.000E+00	0.000E+00	6.135E-04	1.411E-02	5.958E-03	0.000E+00
119	0.000E+00	0.000E+00	4.813E-04	1.527E-02	9.031E-03	0.000E+00
120	0.000E+00	0.000E+00	3.413E-04	1.584E-02	1.225E-02	0.000E+00
121	0.000E+00	0.000E+00	2.083E-04	1.371E-02	1.371E-02	0.000E+00
Maximum	1 0.000E+00	1 0.000E+00	1 1.152E-03	16 1.854E-02	11 1.854E-02	1 0.000E+00
Minimum	1 0.000E+00	1 0.000E+00	2 0.000E+00	34 -1.854E-02	29 -1.854E-02	1 0.000E+00
Average	0.000E+00	0.000E+00	7.032E-04	-1.616E-09	1.185E-09	0.000E+00

## CASE 8

SDRC I-DEAS VI: FE\_Modeling\_&amp;\_Analysis

02-NOV-

93 17:12:13

n92

Group ID : No stored PERMANENT GROUP  
 Analysis Dataset : 2 - CASE 1,LOAD 1,STRESSES  
 Report Type : Contour Units : MG  
 Dataset Type : Stress Load Set : 1  
 Frame of Reference: Global Data Component:  
 Max Prin  
 Surface Type : Top

Node	Max Prin	Mid Prin	Min Prin	Max Shear	Von Mises
1	2.584E+04	0.000E+00	3.859E+03	1.099E+04	2.414E+04
2	-1.529E+05	0.000E+00	-6.293E+05	2.382E+05	5.685E+05
3	2.584E+04	0.000E+00	3.859E+03	1.099E+04	2.414E+04
4	-1.529E+05	0.000E+00	-6.293E+05	2.382E+05	5.685E+05
5	3.363E+04	0.000E+00	-1.518E+03	1.757E+04	3.441E+04
6	5.032E+04	0.000E+00	-6.874E+03	2.860E+04	5.408E+04
7	6.094E+04	0.000E+00	-1.244E+04	3.669E+04	6.802E+04
8	6.729E+04	0.000E+00	-1.846E+04	4.287E+04	7.817E+04
9	6.919E+04	0.000E+00	-2.476E+04	4.697E+04	8.434E+04
10	6.542E+04	0.000E+00	-3.303E+04	4.922E+04	8.678E+04
11	5.328E+04	0.000E+00	-4.110E+04	4.719E+04	8.196E+04
12	2.652E+04	0.000E+00	-6.249E+04	4.450E+04	7.915E+04
13	3.904E+03	0.000E+00	-1.701E+05	8.701E+04	1.721E+05
14	3.903E+03	0.000E+00	-1.701E+05	8.701E+04	1.721E+05
15	2.652E+04	0.000E+00	-6.249E+04	4.450E+04	7.915E+04
16	5.328E+04	0.000E+00	-4.110E+04	4.719E+04	8.196E+04
17	6.542E+04	0.000E+00	-3.303E+04	4.922E+04	8.678E+04
18	6.919E+04	0.000E+00	-2.476E+04	4.697E+04	8.434E+04
19	6.729E+04	0.000E+00	-1.846E+04	4.287E+04	7.817E+04
20	6.094E+04	0.000E+00	-1.244E+04	3.669E+04	6.802E+04
21	5.032E+04	0.000E+00	-6.874E+03	2.860E+04	5.408E+04
22	3.363E+04	0.000E+00	-1.518E+03	1.757E+04	3.441E+04
23	3.363E+04	0.000E+00	-1.518E+03	1.757E+04	3.441E+04
24	5.032E+04	0.000E+00	-6.874E+03	2.860E+04	5.408E+04
25	6.094E+04	0.000E+00	-1.244E+04	3.669E+04	6.802E+04
26	6.729E+04	0.000E+00	-1.846E+04	4.287E+04	7.817E+04
27	6.919E+04	0.000E+00	-2.476E+04	4.697E+04	8.434E+04
28	6.542E+04	0.000E+00	-3.303E+04	4.922E+04	8.678E+04
29	5.328E+04	0.000E+00	-4.110E+04	4.719E+04	8.196E+04

30	2.652E+04	0.000E+00	-6.249E+04	4.450E+04	7.915E+04
31	3.903E+03	0.000E+00	-1.701E+05	8.701E+04	1.721E+05
32	3.904E+03	0.000E+00	-1.701E+05	8.701E+04	1.721E+05
33	2.652E+04	0.000E+00	-6.249E+04	4.450E+04	7.915E+04
34	5.328E+04	0.000E+00	-4.110E+04	4.719E+04	8.196E+04
35	6.542E+04	0.000E+00	-3.303E+04	4.922E+04	8.678E+04
36	6.919E+04	0.000E+00	-2.476E+04	4.697E+04	8.434E+04
37	6.729E+04	0.000E+00	-1.846E+04	4.287E+04	7.817E+04
38	6.094E+04	0.000E+00	-1.244E+04	3.669E+04	6.802E+04
39	5.032E+04	0.000E+00	-6.874E+03	2.860E+04	5.408E+04
40	3.363E+04	0.000E+00	-1.518E+03	1.757E+04	3.441E+04
41	6.754E+04	0.000E+00	-2.445E+04	4.600E+04	8.253E+04
42	6.937E+04	0.000E+00	-2.272E+04	4.604E+04	8.309E+04
43	7.247E+04	0.000E+00	-2.180E+04	4.713E+04	8.548E+04
44	7.489E+04	0.000E+00	-2.151E+04	4.820E+04	8.764E+04
45	7.570E+04	0.000E+00	-2.159E+04	4.864E+04	8.849E+04
46	7.489E+04	0.000E+00	-2.151E+04	4.820E+04	8.764E+04
47	7.247E+04	0.000E+00	-2.180E+04	4.713E+04	8.548E+04
48	6.937E+04	0.000E+00	-2.272E+04	4.604E+04	8.309E+04
49	6.754E+04	0.000E+00	-2.445E+04	4.600E+04	8.253E+04
50	7.489E+04	0.000E+00	-2.151E+04	4.820E+04	8.764E+04
51	7.247E+04	0.000E+00	-2.180E+04	4.713E+04	8.548E+04
52	6.937E+04	0.000E+00	-2.272E+04	4.604E+04	8.309E+04
53	6.754E+04	0.000E+00	-2.445E+04	4.600E+04	8.253E+04
54	7.156E+04	0.000E+00	-2.773E+04	4.965E+04	8.874E+04
55	6.773E+04	0.000E+00	-3.509E+04	5.141E+04	9.052E+04
56	6.081E+04	0.000E+00	-3.936E+04	5.008E+04	8.741E+04
57	5.799E+04	0.000E+00	-3.941E+04	4.870E+04	8.486E+04
58	5.257E+04	0.000E+00	-4.941E+04	5.099E+04	8.834E+04
59	2.588E+04	0.000E+00	-5.442E+04	4.015E+04	7.099E+04
60	5.799E+04	0.000E+00	-3.941E+04	4.870E+04	8.486E+04
61	6.435E+04	0.000E+00	-3.203E+04	4.819E+04	8.502E+04
62	6.831E+04	0.000E+00	-2.962E+04	4.897E+04	8.699E+04
63	6.081E+04	0.000E+00	-3.936E+04	5.008E+04	8.741E+04
64	2.588E+04	0.000E+00	-5.442E+04	4.015E+04	7.099E+04
65	3.349E+04	0.000E+00	-3.629E+04	3.489E+04	6.045E+04
66	7.408E+04	0.000E+00	-2.498E+04	4.953E+04	8.924E+04
67	7.156E+04	0.000E+00	-2.773E+04	4.965E+04	8.874E+04
68	6.831E+04	0.000E+00	-2.962E+04	4.897E+04	8.699E+04
69	6.435E+04	0.000E+00	-3.203E+04	4.819E+04	8.502E+04
70	7.044E+04	0.000E+00	-1.710E+04	4.377E+04	8.037E+04
71	6.642E+04	0.000E+00	-1.346E+04	3.994E+04	7.407E+04
72	6.168E+04	0.000E+00	-1.169E+04	3.668E+04	6.827E+04
73	5.846E+04	0.000E+00	-1.272E+04	3.559E+04	6.575E+04
74	5.431E+04	0.000E+00	-8.211E+03	3.126E+04	5.885E+04
75	4.808E+04	0.000E+00	-8.015E+03	2.805E+04	5.255E+04



76	5.846E+04	0.000E+00	-1.272E+04	3.559E+04	6.575E+04
77	6.484E+04	0.000E+00	-1.838E+04	4.161E+04	7.572E+04
78	6.721E+04	0.000E+00	-1.656E+04	4.189E+04	7.684E+04
79	6.168E+04	0.000E+00	-1.169E+04	3.668E+04	6.827E+04
80	4.808E+04	0.000E+00	-8.015E+03	2.805E+04	5.255E+04
81	3.557E+04	0.000E+00	-4.784E+03	2.018E+04	3.819E+04
82	7.342E+04	0.000E+00	-1.889E+04	4.615E+04	8.446E+04
83	7.044E+04	0.000E+00	-1.710E+04	4.377E+04	8.037E+04
84	6.721E+04	0.000E+00	-1.656E+04	4.189E+04	7.684E+04
85	6.484E+04	0.000E+00	-1.838E+04	4.161E+04	7.572E+04
86	6.754E+04	0.000E+00	-2.445E+04	4.600E+04	8.253E+04
87	6.937E+04	0.000E+00	-2.272E+04	4.604E+04	8.309E+04
88	7.247E+04	0.000E+00	-2.180E+04	4.713E+04	8.548E+04
89	7.489E+04	0.000E+00	-2.151E+04	4.820E+04	8.764E+04
90	5.846E+04	0.000E+00	-1.272E+04	3.559E+04	6.575E+04
91	6.168E+04	0.000E+00	-1.169E+04	3.668E+04	6.827E+04
92	6.642E+04	0.000E+00	-1.346E+04	3.994E+04	7.407E+04
93	7.044E+04	0.000E+00	-1.710E+04	4.377E+04	8.037E+04
94	6.168E+04	0.000E+00	-1.169E+04	3.668E+04	6.827E+04
95	5.846E+04	0.000E+00	-1.272E+04	3.559E+04	6.575E+04
96	4.808E+04	0.000E+00	-8.015E+03	2.805E+04	5.255E+04
97	3.557E+04	0.000E+00	-4.784E+03	2.018E+04	3.819E+04
98	4.808E+04	0.000E+00	-8.015E+03	2.805E+04	5.255E+04
99	5.431E+04	0.000E+00	-8.211E+03	3.126E+04	5.885E+04
100	6.721E+04	0.000E+00	-1.656E+04	4.189E+04	7.684E+04
101	6.484E+04	0.000E+00	-1.838E+04	4.161E+04	7.572E+04
102	6.484E+04	0.000E+00	-1.838E+04	4.161E+04	7.572E+04
103	6.721E+04	0.000E+00	-1.656E+04	4.189E+04	7.684E+04
104	7.044E+04	0.000E+00	-1.710E+04	4.377E+04	8.037E+04
105	7.342E+04	0.000E+00	-1.889E+04	4.615E+04	8.446E+04
106	6.831E+04	0.000E+00	-2.962E+04	4.897E+04	8.699E+04
107	6.081E+04	0.000E+00	-3.936E+04	5.008E+04	8.741E+04
108	5.257E+04	0.000E+00	-4.941E+04	5.099E+04	8.834E+04
109	2.588E+04	0.000E+00	-5.442E+04	4.015E+04	7.099E+04
110	6.081E+04	0.000E+00	-3.936E+04	5.008E+04	8.741E+04
111	6.831E+04	0.000E+00	-2.962E+04	4.897E+04	8.699E+04
112	7.408E+04	0.000E+00	-2.498E+04	4.953E+04	8.924E+04
113	7.156E+04	0.000E+00	-2.773E+04	4.965E+04	8.874E+04
114	6.773E+04	0.000E+00	-3.509E+04	5.141E+04	9.052E+04
115	7.156E+04	0.000E+00	-2.773E+04	4.965E+04	8.874E+04
116	5.799E+04	0.000E+00	-3.941E+04	4.870E+04	8.486E+04
117	6.435E+04	0.000E+00	-3.203E+04	4.819E+04	8.502E+04
118	6.435E+04	0.000E+00	-3.203E+04	4.819E+04	8.502E+04
119	5.799E+04	0.000E+00	-3.941E+04	4.870E+04	8.486E+04
120	2.588E+04	0.000E+00	-5.442E+04	4.015E+04	7.099E+04
121	3.349E+04	0.000E+00	-3.629E+04	3.489E+04	6.045E+04

	45	1	1	2	2
Maximum	7.570E+04	0.000E+00	3.859E+03	2.382E+05	5.685E+05
	2	1	2	1	1
Minimum	-1.529E+05	0.000E+00	-6.293E+05	1.099E+04	2.414E+04
Average	5.351E+04	0.000E+00	-3.907E+04	4.629E+04	8.634E+04

## WORKS CITED

- [ 1 ] H.D. Kaiser, F.J. Pakulski and A.F. Schmeckenbecher. " A Fabrication Technique for Multilayer Ceramic Modules ". *Solid State Technology*, May 1972
- [ 2 ] R.A. Gardener and R.W. Nufer. " Properties of Multilayer Ceramic Green Sheets ". *Solid State Technology*, May 1974
- [ 3 ] Ahmed K. Noor and Jeanne M. Peters. " Postbuckling of Multilayered Composite Plates Subjected to Combined Axial and Thermal Loads ". *Finite Elements in Analysis and Design*, 11 (1992 ) 91-104
- [ 4 ] A.J. Blodgett and D.R. Barbour. " Thermal Conduction Module: A High-Performance Multilayer Ceramic Package". *IBM J. Res. Develop.* Vol. . No. 1. Jan. 1989
- [ 5 ] Felix B. Zyffoff and Alan V. Hall. " An Automated Tool for Multilayer Ceramic Green Sheet Personalization". *IEEE* 1984
- [ 6 ] D. McCloy and D. M. J. Harris. *Robotics: An Introduction*, Halsted Press , John Wiley & Sons, Inc.
- [ 7 ] V. Daniel Hunt, *Understanding Robotics*. Academic Press, Inc. 1990
- [ 8 ] John M. Holland, *Basic Robotics Concepts*, Howard W. Sams & Co. 1986
- [ 9 ] Anthony Esposito and J. Robert Thrower, *Machine Design*, Delmar Publishers Inc. 1991
- [ 10 ] Ananda H. Kumar and Rao R. Tummala, " The Present, and Future of Multilayer Ceramic Multichip Modules in Electronic Packaging ". *JOM*. July 1992
- [ 11 ] D.R. Barbour. " Multichip Module Technology". *Advances in Ceramic*. Volume 19. 1986
- [ 12 ] B. Schwartz " Multilayer Ceramics". *Advances in Ceramic*. Volume 19. 1986
- [ 13 ] John B. Blum and W. Roger Cannon, *Multilayer Ceramic Devices*, The American Ceramic Society, Inc. 1986.
- [ 14 ] C. S. Desai, E.Krempl, G. Frantziskonis, H. Saadatmanesk, *Constitutive Laws For Engineering Materials*, ASME PRESS, 1991.