

Technical Disclosure Commons

Defensive Publications Series

November 2019

Adaptive User Interface for a Camera Aperture within an Active Display Area

Michael J. Lombardi

David K. Lim

Joseph L. Allore

Follow this and additional works at: https://www.tdcommons.org/dpubs_series

Recommended Citation

Lombardi, Michael J.; Lim, David K.; and Allore, Joseph L., "Adaptive User Interface for a Camera Aperture within an Active Display Area", Technical Disclosure Commons, (November 25, 2019)
https://www.tdcommons.org/dpubs_series/2719



This work is licensed under a [Creative Commons Attribution 4.0 License](https://creativecommons.org/licenses/by/4.0/).

This Article is brought to you for free and open access by Technical Disclosure Commons. It has been accepted for inclusion in Defensive Publications Series by an authorized administrator of Technical Disclosure Commons.

Adaptive User Interface for a Camera Aperture within an Active Display Area

Abstract:

This publication describes systems and techniques to account for an active display area around a camera aperture in a “hole-punch” style display of an electronic device to reduce a light-leaking effect caused by pixels surrounding the camera aperture. Illuminated pixels that are proximate to the camera aperture can degrade a quality of an image captured by a camera sensor by preventing the sensor from properly detecting light from a targeted image, such as a user’s face. To counteract this image degradation, techniques described herein override the illumination control for pixels surrounding the hole in the display. For example, responsive to the camera being engaged, one or more rings of pixels around the display hole can be controlled to have a decreased illumination level based on ambient brightness. The decreased illumination can involve being commanded to be turned off or being commanded to illuminate at a lower level. With less light emanating from pixels that are proximate to the display hole, there is less light pollution funneled into the camera aperture to affect the camera sensor.

Keywords:

smartphone, display, organic light-emitting diode (OLED) display, hole-punch, punch-hole, notch, camera aperture, front-facing camera, image quality, light leakage, ambient brightness, pixel, ring, illumination, darken, gradient

Background:

Many types of electronic devices include both a display screen and at least one camera. To maximize a viewable screen size, devices with modern form factors that adhere to an industrial design philosophy are being produced in which greater than 90% of one surface, such as the front surface, is dedicated to the display screen. Some of these electronic devices, such as many smartphones, also include a front-facing camera. Due to the relatively large size of the display screen on the front surface, some devices incorporate the front-facing camera in the same surface area as the display screen. To do so, device manufacturers carve out a portion of the display to leave space for the camera to “see” out of the front surface of the device.

For example, some smartphones include a hole in the display screen, such as a circular hole, that does not include pixels. This display hole can serve as a portal for the camera. Accordingly, an image sensor for the camera is mounted behind the display screen in a manner to provide the sensor a view through the hole. This architecture that combines a display hole and a camera is sometimes called a “punch-hole camera” or a “hole-punch display.” Unfortunately, even with a display hole, an image quality can be degraded if the front-facing camera is used simultaneously with an active display. Illuminated pixels that are proximate to the display hole, such as those that surround the hole, can interfere with the image sensor trying to capture a view as intended by the user.

In other words, the light from illuminated pixels may impact an image sensor. For example, a glass or plastic substrate, or a cover, for pixels of the display screen can act like a lightguide to direct light from illuminated pixels to the edge of the substrate around the display hole. This lightguide effect can intensify the impact of bright pixels that are adjacent, or at least proximate, to the display hole. Thus, the image sensor may detect the light from the illuminated pixels as well

as the light from the intended view, such as the user's face during video communication. This can create noise across a detected image. Further, a region of the detected image that is nearest the display hole can be partially washed out. Therefore, it is desirable to reduce harmful effects on image quality caused by illuminated pixels that are proximate to a hole that is included in a display for a camera aperture.

Description:

This publication describes systems and techniques for separately controlling pixels that are proximate to a display hole around a camera aperture. Illumination of the proximate pixels is controlled separately by reducing an illumination level based at least on an ambient brightness in the environment or a target of the camera. For example, the illumination level can be reduced based on the ambient brightness and an ambient threshold to reduce adverse effects on image quality due to light leakage.

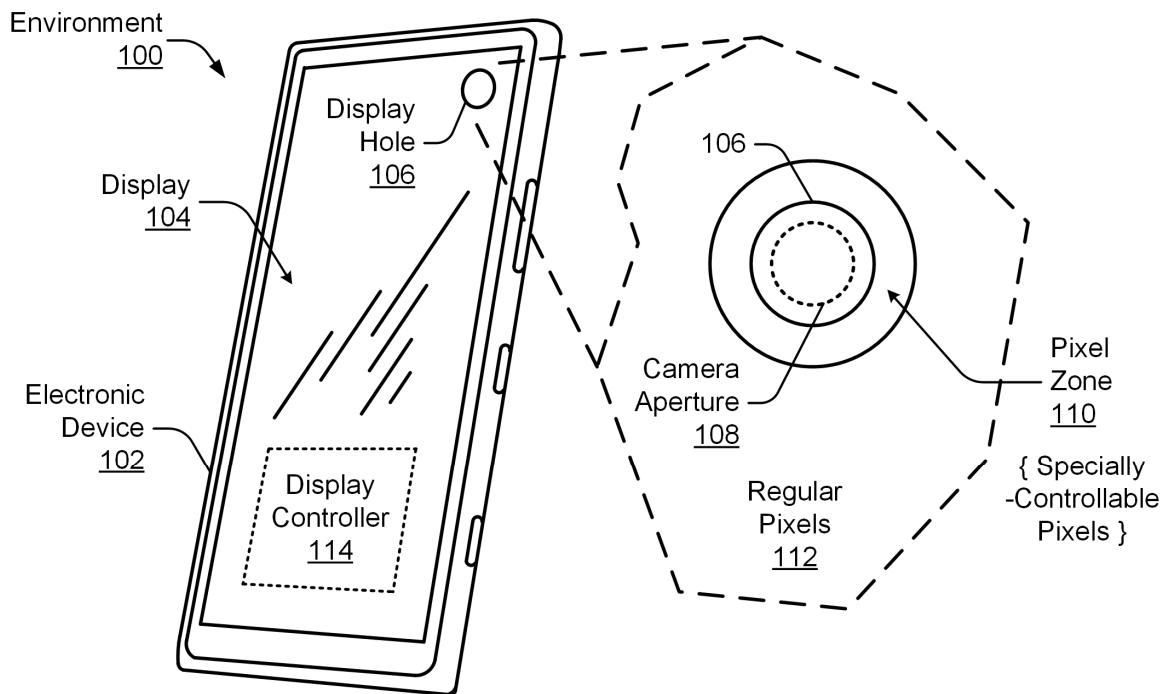

Fig. 1. Electronic device including a pixel zone around a display hole.

As shown in Fig. 1, an environment 100 includes an electronic device 102 with a display 104. The electronic device 102 can be realized as any electronic device having a camera on the same surface as the display 104, whether the surface is the front, back, or side of the device. Examples of the electronic device 102 include phones (e.g., smartphones), tablet computers, laptops, convertibles, personal digital assistants (PDAs), security devices, video communication devices, devices with foldable screens, and so forth. The display 104 can be implemented as a liquid crystal display (LCD), an organic light-emitting diode (OLED) display, another display with individually-controllable pixels, and so forth. As shown, the display 104 includes or defines a display hole 106.

A camera (which is illustrated in Fig. 2) of the electronic device 102 is mounted behind the display 104, but the camera can still “see” through the display 104 via the display hole 106. The display hole 106 encompasses a camera aperture 108 for the camera. Although depicted as a circular or oval shape, the display hole 106 can instead be a rectangle, a non-circular curved shape, any polygonal shape, and so forth. Further, although the carved-out area that is devoid of pixels is referred to herein as a “hole,” the described principles are applicable to other structures. For example, the described light-leakage compensation strategies are applicable to a notch or other carved-out shape near an edge of a display and to any junction generally between a camera aperture and proximate pixels that may be illuminated while the camera is engaged.

To the right of the electronic device 102 in Fig. 1, a display region around the display hole 106 is enlarged. The camera aperture 108 enables light to enter the camera, which is shown in Fig. 2. The camera aperture 108 is surrounded by the display hole 106. A pixel zone 110 is defined proximate to the display hole 106. Pixels of the pixel zone 110 are proximate to the display hole 106 if, for example, the pixels are sufficiently close to the camera aperture 108 to potentially

adversely impact the ability of the camera to capture light from an intended photographic target. For instance, the pixels of the pixel zone 110 may be adjacent to the display hole 106 or contiguous with those pixels that are adjacent to the display hole 106 (e.g., within 5-50 pixels). The pixels of the pixel zone 110 are specially controllable relative to regular pixels 112 of the display 104.

As described herein, the pixels of the pixel zone 110 are provided with separate illumination commands responsive to the camera being engaged and based on one or more conditions, such as ambient brightness. The electronic device 102 includes a display controller 114. The display controller 114 issues the separate illumination commands for the pixel zone 110 to at least moderate the deleterious effects of light leakage onto, or light pollution of, a camera sensor of a camera. The display controller 114 can be implemented in hardware, firmware, software, some combination thereof, and so forth. For example, the display controller 114 can be realized as part of a graphics processing unit (GPU) or graphics chip, a hardware video controller, a system-on-chip (SoC), a video buffer controller, or a combination thereof. Additionally or alternatively, the display controller 114 can be implemented as part of an operating system (OS), a device driver for the display 104, an application (e.g., an application that accesses the camera), and so forth.

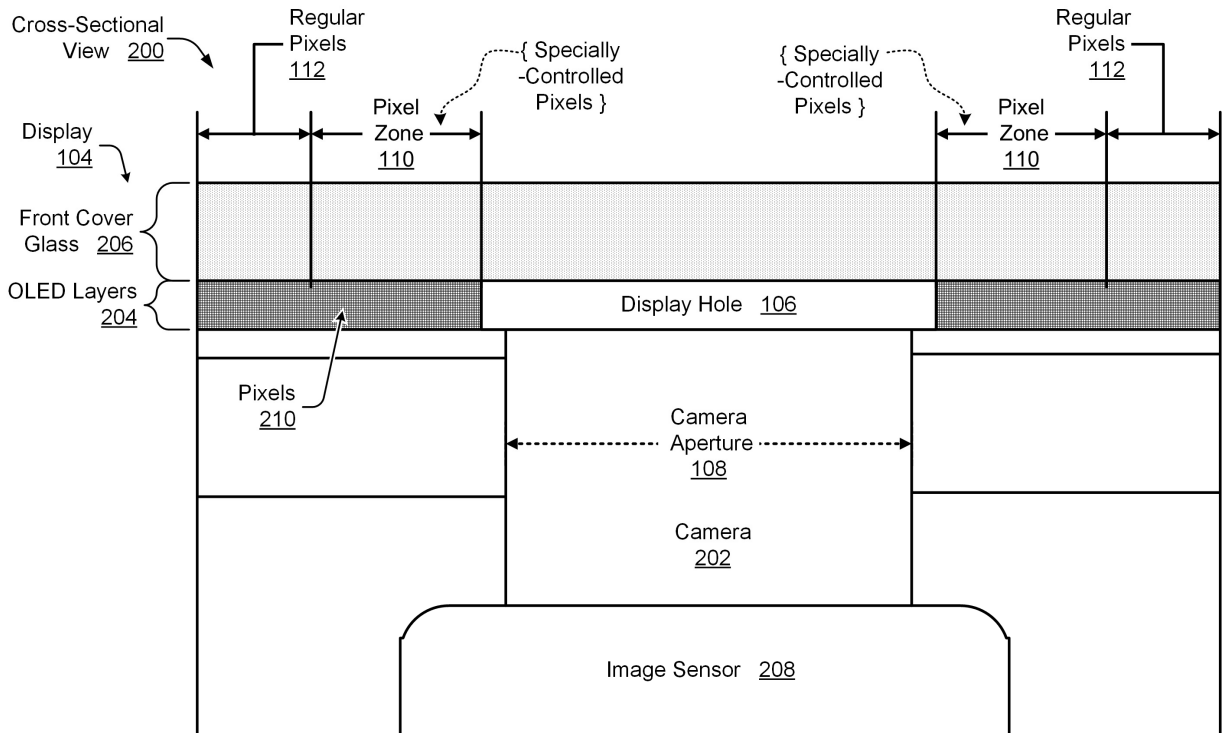

Fig. 2. Cross-sectional view of camera and display with specially-controlled pixel zone.

Fig. 2 depicts an example cross-sectional view 200 of part of the electronic device 102 (of Fig. 1). The cross-sectional view 200 includes the display 104 and a camera 202. In this example, the display 104 includes one or more OLED layers 204 and a front cover glass 206. The front cover glass 206 protects the OLED layers 204. The OLED layers 204 include multiple pixels 210. The OLED layers 204 also include or define the display hole 106.

The camera 202 includes the camera aperture 108 and at least one image sensor 208. In operation, light from a photographic target, such as a user for a “selfie,” enters the camera aperture 108 through the front cover glass 206 via the display hole 106. The light travels through the camera aperture 108 to impact the image sensor 208, and the image sensor 208 captures the light to obtain an image of the target. However, light from illuminated pixels 210 can also leak into the camera aperture 108, such as by being reflected by the front cover glass 206 or routed along the OLED

layers 204 like a lightguide. This light from the illuminated pixels 210 is effectively light pollution that adversely impacts the quality of the image captured by the image sensor 208.

To counteract the light pollution, at least one pixel zone 110 is established in the OLED layers 204 in an area that is proximate to the display hole 106. In operation, the pixel zone 110 can form a light buffer between the camera aperture 108 and regular pixels 112 to reduce the amount of light pollution that leaks into the camera aperture 108. As explained below with reference to Fig. 3 and 4, pixels of the pixel zone 110 are specially controlled to decrease light leakage into the camera aperture 108 responsive to engagement of the camera 202.

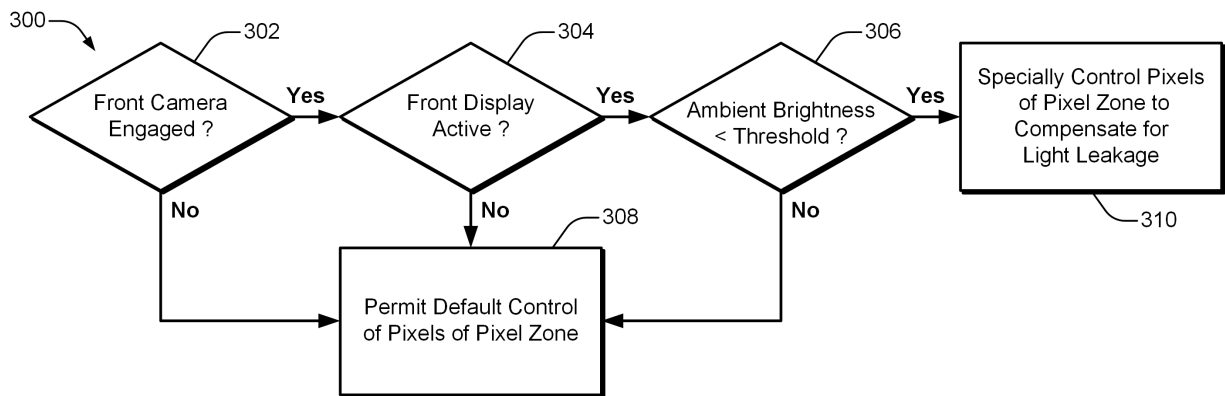

Fig. 3. Flowchart for light-leakage compensation process.

A flowchart 300 of Fig. 3 is described in terms of an electronic device 102 (of Fig. 1) that includes, for example, both a front display and a front-facing camera. As shown at 302, the display controller 114 determines if the front camera is engaged—e.g., is being used to capture a picture or video. If not, then at 308 a default control of the pixels 210 in the pixel zone 110 is permitted to occur. In other words, the illumination commands that are intended for the pixel zone 110 to blend normally with the regular pixels 112 are sent to the pixels 210 of the pixel zone 110.

On the other hand, if the front camera is engaged, then at 304 the display controller 114 determines if the front display is active. If the front display 104 is not active, then the default control is permitted at 308. Here, with an inactive display, the pixels 210 of both the pixel zone

110 and the regular pixels 112 are permitted to remain dark. If the front camera is engaged and the front display is active, the display controller 114 determines if the light-leakage compensation is triggered using one or more analyses.

At 306, an ambient brightness is analyzed. For example, the display controller 114 can compare a detected ambient brightness to at least one ambient threshold. If the ambient brightness is greater than the ambient threshold (or if the ambient brightness is not less than the ambient threshold), then the default pixel control of the pixel zone 110 is permitted at 308. Otherwise, if the ambient brightness is less than the ambient threshold, then the default illumination control of the pixels of the pixel zone 110 is overridden. For example, at 310, the display controller 114 can specially control the pixels 210 of the pixel zone 110 to compensate for light leakage. Example light-leakage compensation schemes are described below with reference to Fig. 4.

In one alternative, a light-leakage compensation scheme can be triggered regardless of an ambient brightness whenever the front display is active while the camera is engaged. Generally, light-leakage compensation can be triggered based on different conditions or using different analyses. For example, additionally or alternatively to the ambient brightness analysis of 306, the triggering can be based on a display brightness. For instance, a light-leakage compensation scheme can be triggered if the display brightness is greater than a display threshold. Further, light-leakage compensation can be triggered based on considering both an ambient brightness relative to an ambient threshold and a display brightness relative to a display threshold.

As another example, triggering of a light-leakage compensation scheme can be based on a comparison of an ambient brightness to a display brightness, with or without using at least one brightness threshold. In other words, a level of ambient brightness can be directly or indirectly compared to a level of display brightness. In one scenario, if a display brightness is set to 100%,

then an ambient brightness may be expected to be at a higher level to avoid triggering light-leakage compensation than if the display brightness is set to 25%. This can be implemented, for instance, by utilizing multiple ambient thresholds that vary based on a display brightness level.

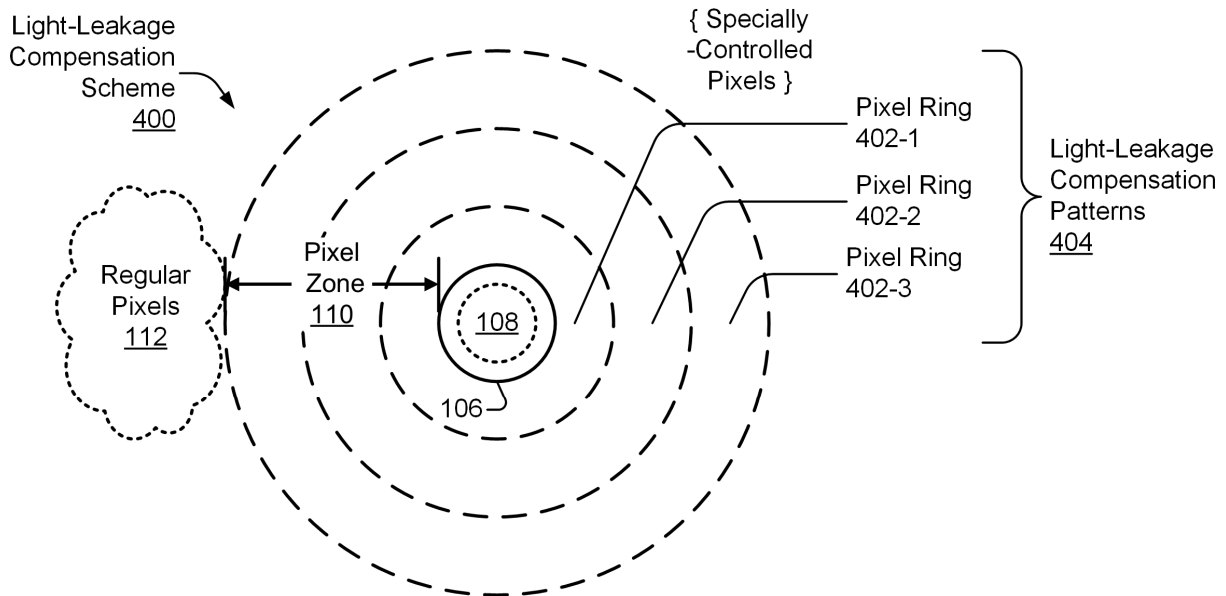

Fig. 4. Pixel zone for different light-leakage compensation patterns.

Fig. 4 illustrates an example light-leakage compensation scheme 400 with a pixel zone 110 that extends between a display hole 106 and regular pixels 112. The pixel zone 110 is separated into two or more pixel rings 402. As shown, the pixel zone 110 includes three example pixel rings: a first pixel ring 402-1, a second pixel ring 402-2, and a third pixel ring 402-3. Nonetheless, the pixel zone 110 can include a different quantity of pixel rings 402. Each pixel ring 402 is depicted as a circle. However, a pixel ring can form a different shape to contour around the display hole 106. Described principles are also applicable to groups of pixels that are not organized into a closed shape, such as those positioned along a carved-out notch of a display. Each pixel ring 402 can have a width of 1, 2, 8, 15, or more pixels. Also, each pixel ring 402 can have the same width or a different width as compared to other pixel rings 402.

In example operations, the display controller 114 can send the pixels of the pixel zone 110 illumination commands such that the multiple pixel rings 402-1 to 402-3 can be controlled using different light-leakage compensation patterns 404 in low-light environments. In a first example of a light-leakage compensation pattern 404, a total quantity of the pixel rings 402 in the pixel zone 110 have their illumination reduced to zero (e.g., the pixels are turned off for an OLED display or turned black for an LCD) responsive to the light-leakage compensation scheme 400 being triggered by the compensation process 300 (of Fig. 3). For this first example, the three depicted pixel rings 402-1 to 402-3 are each commanded to have zero illumination. In a second example of a light-leakage compensation pattern 404, a quantity of pixel rings 402 that are being adjusted (e.g., darkened) may be increased at lower ambient brightness levels and reduced at higher ambient brightness levels. For this second example, the first pixel ring 402-1 may be adjusted responsive to a detected high ambient brightness level, but the first through third pixel rings 402-1 to 402-3 may be adjusted responsive to a detected low ambient brightness level.

In a third example of a light-leakage compensation pattern 404 that can be implemented in low-light environments, the illumination of each pixel ring 402 of the multiple pixel rings 402-1 to 402-3 may be adjusted a same amount or different amounts. For this third example, each pixel ring 402 may be commanded to darken to a same degree in some cases. In other cases, the multiple pixel rings 402-1 to 402-3 may form a gradient pattern of illumination. For instance, the first pixel ring 402-1, which is closest to the camera aperture 108, is commanded to illuminate at a lowest level while the third pixel ring 402-3 farthest from the display hole 106 is illuminated at the highest level. Here, the second pixel ring 402-2 is illuminated at an intermediate level.

References:

[1] Patent Publication: US20160337570A1. Camera included in display. Priority Date: January 31, 2014.

[2] Patent Publication: US20170116932A1. System and method for coordinating image capture in a camera hidden behind a display device. Priority Date: March 20, 2014.