

Saint Louis University Law Journal

Volume 54
Number 1 (Fall 2009)

Article 4

2009

Allocating Patent Rights Between Earlier and Later Inventions

Charles W. Adams

University of Tulsa College of Law, chuck-adams@utulsa.edu

Follow this and additional works at: <https://scholarship.law.slu.edu/lj>



Part of the [Law Commons](#)

Recommended Citation

Charles W. Adams, *Allocating Patent Rights Between Earlier and Later Inventions*, 54 St. Louis U. L.J. (2009).

Available at: <https://scholarship.law.slu.edu/lj/vol54/iss1/4>

This Article is brought to you for free and open access by Scholarship Commons. It has been accepted for inclusion in Saint Louis University Law Journal by an authorized editor of Scholarship Commons. For more information, please contact [Susie Lee](#).

**ALLOCATING PATENT RIGHTS BETWEEN EARLIER AND LATER
INVENTIONS**

CHARLES W. ADAMS*

INTRODUCTION 56

I. HISTORICAL BACKGROUND OF BLOCKING PATENTS 65

II. THE ENABLEMENT, WRITTEN DESCRIPTION, AND
NONOBVIOUSNESS REQUIREMENTS 71

III. THE POLYPROPYLENE LITIGATION..... 82

A. The Chemistry of Polypropylene 82

B. The Natta Patent..... 85

C. The Hogan and Banks Patent 87

D. In re Hogan..... 92

E. Enforcement of the Hogan and Banks Patent..... 98

IV. RECENT FEDERAL CIRCUIT CASE LAW 102

CONCLUSION..... 111

* Professor of Law at the University of Tulsa College of Law. I want to thank the participants at the Intellectual Property Scholars Conference at Stanford University, where an earlier draft of this paper was presented in August, 2008. I especially thank Mark Lemley, Kevin Emerson Collins, and Ted M. Sichelman for their helpful comments and suggestions. I am also grateful to my colleague, Robert Spoo, for many helpful discussions concerning this paper. Finally, I thank the University of Tulsa for a Research Grant that provided financial support for this paper.

INTRODUCTION

Technological progress is generally cumulative. Most often, inventors rely on the discoveries of others to make a new discovery, and so the new discovery is really a combination of the old with the new. When this occurs, the issue of how to allocate intellectual property rights between the former and later inventors may arise. Obviously, there are tradeoffs.¹ Granting all the intellectual property rights to the first inventor (or inventors, if the later inventor relies on multiple prior inventors) removes the incentive for the later inventor to make the new discovery because the first inventor would reap all the rewards from both the initial and new discoveries. If the first inventor lacks either the expertise or sufficient incentive to make the new discovery, there may be no technological progress.

On the other hand, granting all the intellectual property rights to the later inventor may remove at least some of the incentive for the first inventor to make the original discovery. While the first inventor still would have the benefit of intellectual property rights from the original discovery, these may not be very valuable if the new discovery competes with the original discovery or renders it obsolete. Denying the first inventor intellectual property rights in the new discovery could make enough of a difference that the first inventor would not have sufficient incentive to make the original discovery in the first place.² Again, there may be no technological progress, especially if the new discovery would not have been possible without the original discovery.

It would appear that allocation of intellectual property rights requires consideration of a variety of factors. One of these might be the relative significance of the contributions of the first and second inventors. Surely, the inventor that makes the greater contribution ought to receive the larger share of the rewards from cumulative inventions. An original invention may facilitate a later invention in at least three ways.³ In some cases, the later invention might not be possible without the first.⁴ In other cases, the original invention might reduce the cost of development of the later invention, or accelerate the later invention's development.⁵ To the extent that an original invention makes the

1. See generally Suzanne Scotchmer, *Standing on the Shoulders of Giants: Cumulative Research and the Patent Law*, 5 J. ECON. PERSP. 29, 30 (1991) ("The challenge is to reward early innovators fully for the technological foundation they provide to later innovators, but to reward later innovators adequately for their improvements and new products as well.").

2. Jerry R. Green & Suzanne Scotchmer, *On the Division of Profit in Sequential Innovation*, 26 RAND J. ECON. 20, 20 (1995) ("[T]he social value of an early innovation includes the net social value of the applications it facilitates. If the first innovator does not collect that value as profit, he might not invest even if the combined profit of the innovations exceeds the combined costs.").

3. See Scotchmer, *supra* note 1, at 31.

4. *Id.*

5. *Id.*

development of a later invention possible, cheaper, or faster, the social value of the original invention would include a portion of the later invention's value, and the intellectual property rights to the second invention should be allocated to the original inventor accordingly.⁶ Another factor might be the payoffs the first and second inventors need to recover their costs of making their respective discoveries.⁷ Depending on the specific circumstances, these factors may be more or less difficult to ascertain.

Copyright law awards all the intellectual property rights to the first creator of an original work of authorship and no copyright to a creator of a derivative work made without the permission of the first creator.⁸ In contrast, patent law authorizes an inventor of an improvement to an original invention to obtain a patent on the improvement, provided that the improvement satisfies the standards for patentability.⁹ A possible reason for this difference is that the range of potential works of authorship is greater than the range of improvements for inventions. The range of potential works of authorship is limited only by the imagination of the author. The author of a screenplay about a sports figure does not have to use the character of Rocky Balboa, for example, but is free to make up an original character, while Sylvester Stallone retains all the rights to develop derivative works based on the Rocky character.¹⁰ Thus, the ability of later authors to obtain intellectual property rights for their new works of authorship is not irretrievably constrained by awarding all the intellectual property rights to the first creator of an original work of authorship. Patentable inventions, on the other hand, are constrained

6. *Id.*

7. *See Green & Scotchmer, supra* note 2, at 21.

8. *See, e.g. Schrock v. Learning Curve Int'l, Inc.*, 586 F.3d 513, 522 (7th Cir. 2009) ("To be copyrightable, a derivative work must not be infringing."); *Mulcahy v. Cheetah Learning L.L.C.*, 386 F.3d 849, 852 (8th Cir. 2004) ("[B]ecause the owner of the original copyright has the exclusive right to prepare derivative works, the creator of an original derivative work is only entitled to a copyright if she had permission to use the copyrighted work."). Damages for copyright infringement, however, are limited to the amount of the infringer's profits attributable to the original work. *See* 17 U.S.C. § 504(b) (2000) ("The copyright owner is entitled to recover . . . any profits of the infringer that are attributable to the infringement . . ."); *Sheldon v. Metro-Goldwyn Pictures Corp.*, 309 U.S. 390, 396 (1940) ("[I]n computing an award of profits against an infringer of a copyright, there may be an apportionment so as to give to the owner of the copyright only that part of the profits found to be attributable to the use of the copyrighted material as distinguished from what the infringer himself has supplied.>").

9. *See* 35 U.S.C. § 101 (2000) (authorizing inventor of "any new and useful improvement" of an invention to obtain a patent for the improvement).

10. *See Anderson v. Stallone*, No. 87-0592 WDKGX, 1989 WL 206431, at *6 (C.D. Cal. Apr. 25, 1989).

by the laws of nature, because they must actually work to be patentable.¹¹ An inventor is not as free to make up an improvement that does not rely on an original invention as a later author is to create a work of authorship that does not rely on an original work of authorship. Accordingly, there may be greater justification for awarding intellectual property rights to the inventor of an improvement than there is for awarding them to the author of a derivative work.¹²

While an inventor of an improvement to an original invention may receive a patent, the patent on the improvement could potentially be subject to a patent on the original invention. In these circumstances, neither the inventor of the improvement nor the inventor of the original invention would be allowed to make, use, offer to sell, or sell the improvement without the consent of the other.¹³ The patent on the improvement would block the inventor of the original invention from practicing the improvement without permission of the improvement's inventor, and if the improvement is within the scope of the patent on the original invention, the patent on the original invention would block the improvement's inventor from practicing the improvement without permission of the inventor.¹⁴ Third parties who wish to practice the invention on the improvement would have to get permission from both inventors. Consequently, the first and second inventors would share the intellectual property rights in the patent on the improvement with the allocation of the licensing revenue left to negotiation between them.¹⁵

11. See 35 U.S.C. § 101 (2006) (requiring inventions to be useful); 35 U.S.C. § 112 (2006) (requiring patent applications to contain a written description of the invention that enables a person of ordinary skill in the area to make and use the invention).

12. For a more thorough analysis of the different treatments of improvements to inventions in patent law and derivative works in copyright law, see Mark A. Lemley, *The Economics of Improvement in Intellectual Property Law*, 75 TEX. L. REV. 989 (1997). Professor Lemley calls the reason presented in the text for the differing treatment of improvements under patent and copyright law the "different works" argument. *Id.* at 1034–38. He also considers three additional justifications for the differing treatment that he calls the moral rights, balance of power, and market power arguments. *Id.* at 1031–34, 1038–42. He ultimately rejects all these arguments and concludes that copyright law should be modified to conform more closely to the patent law approach for allocating intellectual property rights in improvements. *Id.* at 1044, 1069, 1084.

13. 35 U.S.C. § 271(a) (2006).

14. Lemley, *supra* note 12, at 1000–01.

15. See Robert Merges, *Intellectual Property Rights and Bargaining Breakdown: The Case of Blocking Patents*, 62 TENN. L. REV. 75, 81 (1994) ("An independent patent on an improvement . . . facilitates improver-pioneer bargaining."). In the context of injunctive relief in litigation, the allocation of profits between first and second inventors might be accomplished through conditioning the issuance of injunctive relief on the payments between the inventors. See 35 U.S.C. § 283 (2006) (authorizing a federal court to grant injunctive relief for patent infringement "on such terms as the court deems reasonable").

The situation is an example of a bilateral monopoly in which two parties have to bargain with each other over something of value.¹⁶ In the absence of a market to determine a price within the bargaining range, the parties to a bilateral monopoly may incur substantial costs to arrive at a settlement point, or they could be unable to settle with each other at all.¹⁷ Similarly, two inventors with blocking patents may be unable to agree on the allocation of their intellectual property rights in the improvement with the result that neither they nor any third parties would be able to make, use, offer to sell, or sell the improvement. Blocking patents could therefore interfere with technological progress.¹⁸

Whether a patent on an original invention blocks a patent on a later invention depends on the scope of the patent on the original invention and whether the later invention comes within the scope of the patent on the original invention. The scope of a patent generally depends on its claims, which are found at the end of the specification in the patent application and the issued patent.¹⁹ Usually a patent attorney will draft patent claims as broadly as possible in order to maximize the coverage. There are a number of constraints, however, on the scope of claims available to a patent drafter.

On the one hand, the scope is constrained by the prior art in the field. The requirement of “novelty,” for example, bars claims from encroaching on inventions that were known or used by others in the United States, or that were described in a printed publication anywhere in the world before the patent applicant’s own invention.²⁰ In addition, the requirement of “nonobviousness” bars claims for an invention whose differences from the prior art are such that the new invention would have been obvious to a person having ordinary skill in the art at the time the patent applicant first made the invention.²¹

16. For discussions of bilateral monopoly, see *In re Hopkins*, 102 F.3d 311, 315 (7th Cir. 1996) (Posner, J.), *abrogated on other grounds by* *Associates Commercial Corp. v. Rash*, 520 U.S. 953 (1997); *Walgreen Co. v. Sara Creek Prop. Co.*, 966 F.2d 273, 276 (7th Cir. 1992) (Posner, J.); RICHARD A. POSNER, *ECONOMIC ANALYSIS OF LAW* 62, 597–98 (7th ed. 2007).

17. *Walgreen*, 966 F.2d at 276.

18. For examples of blocking patents interfering with progress in the early electrical lighting industry and the development of automobile, aircraft, and radio technology, see Robert P. Merges & Richard R. Nelson, *On the Complex Economics of Patent Scope*, 90 COLUM. L. REV. 839, 885–93 (1990).

19. The patent case law has also developed a doctrine of equivalents, which in some cases may extend the range of a patent beyond the literal scope of the claims. The additional range from the doctrine of equivalents is limited to insubstantial variations that perform the same function in substantially the same way to produce the same result as the original invention, and it is therefore dependent on the literal scope of the claims. For additional discussion of the doctrine of equivalents, see *infra* text accompanying notes 163–83.

20. See 35 U.S.C. § 102(a) (2006).

21. See *id.* § 103(a).

On the other hand, the scope of claims is constrained by the disclosures that the patent applicant makes in the specification in the patent application. The specification is required to provide a written description of the invention, as well as the process for making and using it, that is sufficient to enable any person who is skilled in the art to make and use the invention.²² In addition, the specification must elaborate the best mode for carrying out the invention that the inventor contemplated.²³

It would seem that combining the enablement requirement for an original patent with the nonobviousness requirement for a later patent would preclude the possibility that the original patent could block the later patent.²⁴ If the first inventor failed to provide a written description that enabled any person skilled in the art to make and use the later invention, then the enablement requirement would bar the first inventor from including the later invention in the claims in the original patent. The original patent consequently would not block the later patent because the later patent would be outside the original patent's scope. On the other hand, if the first inventor did provide a written description that enabled a person skilled in the art to make and use the later invention without undue experimentation, then the original patent would have been part of the prior art with respect to the later invention. So the second patent would be invalid on account of the nonobviousness requirement.

Despite this syllogism, the existence of blocking patents has long been recognized by the courts as well as by academic commentators.²⁵ One common circumstance where blocking patents may occur is where the improvement to a prior invention consists of the combination of a component with the prior invention.²⁶ If the prior invention is represented as "A," then the improvement may be represented as "A + B."²⁷ Even though the combination may be patentable if it is nonobvious, a patent on the prior invention will block practice of the combination, because the practice of the combination

22. *See id.* § 112.

23. *Id.*

24. *See* Kevin Emerson Collins, *The Reach of Literal Claim Scope Into After-Arising Technology: On Thing Construction and the Meaning of Meaning*, 41 CONN. L. REV. 493, 511 (2008) ("Whenever there are blocking patents, the literal scope of N's earlier or 'dominant' claim reaches beyond what N actually invented and encompasses the things produced by N+1's later or 'subservient' invention."); Robert P. Merges, *Rent Control in the Patent District: Observations on the Grady-Alexander Thesis*, 78 VA. L. REV. 359, 379–80 n.73 (1992) (describing the possibility that an improvement invention may be both nonobvious and infringing as a conundrum).

25. *See, e.g.,* Merges & Nelson, *supra* note 18, at 861 n.96.

26. *See* Lemley, *supra* note 12, at 1009 ("[A]dding to an infringing machine does not relieve a defendant of liability for an infringement."). For an example of blocking patents resulting from the combination of a component with a prior invention, see *infra* text accompanying notes 81–83.

27. *See* Atlas Powder Co. v. E.I. du Pont De Nemours & Co., 750 F.2d 1569, 1580 (Fed. Cir. 1984).

necessarily entails infringement of the patent on the prior invention.²⁸ An example might be the combination of a pencil with an eraser. Assuming that a patent on the pencil was valid, the combination of the pencil with an eraser might also satisfy the requirements for patentability, but the combination could not be made or used without infringing the patent on the pencil.²⁹ Consequently, the patent on the prior invention will dominate a patent on the combination. Moreover, under the “entire market value rule,” damages for infringement of a prior invention will not be allocated between the prior invention and a component, but rather, will be based on the profits from sales of the combination as long as the combination of the prior invention with the component constitute a functional unit.³⁰

In most situations, the development of the combination would likely not have been possible without the prior invention, and, therefore, it is appropriate for a patent on the prior invention to be allocated substantial intellectual property rights in the subsequent combination. It is conceivable, however, that the development of the combination may have occurred independently of the prior invention.³¹ If the prior invention did not make the development of the combination possible, cheaper, or faster, allocating intellectual property rights in the combination might not be appropriate from an economic standpoint.

Another circumstance where blocking patents may occur is where one patent is on a machine, manufacture, or composition of matter, and another patent exists for a process to make or use the machine, manufacture, or composition of matter. This possibility for blocking patents arises from the disjunctive elements for infringement in 35 U.S.C. § 271(a): “[W]hoever without authority makes, uses, offers to sell, or sells any patented invention . . . during the term of the patent therefore, infringes the patent.”³² An inventor of a novel, useful, and nonobvious process for using or making a machine, manufacture, or composition of matter would be entitled to a patent for the process, even if the machine, manufacture, or composition of matter

28. *Id.*; Lemley, *supra* note 12, at 1009 (“Thus, if the improvement consists of additions to the basic structure claimed in the original patent, that improvement will not avoid infringement even though it would not have been obvious to the original patentee.”).

29. I am indebted to Mark Lemley for this illustration.

30. *Cf.* *Am. Seating Co. v. USSC Group, Inc.*, 514 F.3d 1262, 1268 (Fed. Cir. 2008) (“A patentee may recover lost profits on unpatented components sold with a patented item, a conveyed sale, if both the patented and unpatented products ‘together were considered to be components of a single assembly or parts of a complete machine, or they together constituted a functional unit.’” (quoting *Rite-Hite Corp. v. Kelley Co., Inc.*, 56 F.3d 1538, 1550 (Fed. Cir. 1995))); *Rite-Hite Corp. v. Kelley Co., Inc.*, 56 F.3d 1538, 1549–50 (Fed. Cir. 1995).

31. For the example of polypropylene, see *infra* text accompanying notes 187–229 and 338–43.

32. 35 U.S.C. § 271(a) (2006).

was subject to its own patent.³³ Nevertheless, the patent on the process could not be exploited without a license from the patentee of the patent on the machine, manufacture, or composition of matter. Under § 271(a), any process for making or using a patented machine, manufacture, or composition of matter would infringe the patent on the machine, manufacture or composition of matter, regardless of whether the process for making or using the patented invention was itself novel and nonobvious.³⁴

Judge Rader provided the following hypothetical illustrating blocking patents on a composition for shoe polish and a process for using the composition to grow hair in *Catalina Marketing International, Inc. v. Coolsavings.com, Inc.*:

Inventor A invents a shoe polish for shining shoes (which, for the sake of example, is novel, useful, and nonobvious). Inventor A receives a patent having composition claims for shoe polish. Indeed, the preamble of these hypothetical claims recites “a composition for polishing shoes.” Clearly, Inventor B could not later secure a patent with composition claims on the same composition because it would not be novel. Likewise, Inventor B could not secure claims on the method of using the composition for shining shoes because the use is not a “new use” of the composition but, rather, the same use shining shoes.

Suppose Inventor B discovers that the polish also repels water when rubbed onto shoes. Inventor B could not likely claim a method of using the polish to repel water on shoes because repelling water is inherent in the normal use of the polish to shine shoes. In other words, Inventor B has not invented a “new” use by rubbing polish on shoes to repel water. Upon discovering, however, that the polish composition grows hair when rubbed on bare human skin, Inventor B can likely obtain method claims directed to the new use of the composition to grow hair. Hence, while Inventor B may obtain a blocking patent on the use of Inventor A’s composition to grow hair, this method patent does not bestow on Inventor B any right with respect to the patented

33. See 35 U.S.C. § 100(b) (2006) (“The term ‘process’ . . . includes a new use of a known process, machine, manufacture, composition of matter, or material.”). Before the adoption of this provision in 1952, a new use of an old product or composition was held to be not patentable. *Roberts v. Ryer*, 91 U.S. 150, 157 (1875) (“It is no new invention to use an old machine for a new purpose. The inventor of a machine is entitled to the benefit of all the uses to which it can be put, no matter whether he had conceived the idea of the use or not.”); *In re Thuau*, 135 F.2d 344, 347 (C.C.P.A. 1943) (“[A] patent for a new use for an old substance quite unchanged is not authorized by the patent laws because such use is not the invention or discovery of ‘any new and useful art, machine, manufacture, or composition of matter, or any new and useful improvements thereof’ as required by Section 4886 of the Revised Statutes, U.S.C. Title 35, Sec. 31, 35 U.S.C.A. § 31.”); Paul H. Eggert, *Uses, New Uses and Chemical Patents—A Proposal*, 51 J. PAT. OFF. SOC’Y 768, 775–80 (1969).

34. *Catalina Marketing Int’l, Inc. v. Coolsavings.com, Inc.*, 289 F.3d 801, 809 (Fed. Cir. 2002).

composition. Even though Inventor A's claim recites "a composition for polishing shoes," Inventor B cannot invoke this use limitation to limit Inventor A's composition claim because that preamble phrase states a use or purpose of the composition and does not impose a limit on Inventor A's claim.³⁵

Thus, a patent for a composition or product will dominate patents for processes for making or using the composition or product.

As a matter of logic, the existence of a product would be essential to the development of a process for using the product. Thus, it makes economic sense to allocate substantial intellectual property rights in the process to the holder of the patent on the product. It is less clear, however, that the holder of the patent on the product should be allocated substantial intellectual property rights in a novel and nonobvious process for making the product. The enablement requirement for a patent on a product is satisfied if the specification enables any method of making and using the product.³⁶ In contrast, the enablement requirement for a patent on a process for making or using a product would not be satisfied unless the specification enabled the particular process that was claimed.³⁷ It is certainly possible that one process for making a product could be developed independently of another process for making the product. If the first process for making the product did not make the second process possible, cheaper, or faster in any way, it would probably not be appropriate from an economic standpoint to allocate substantial intellectual property rights in the second process to the product's patent holder. Nevertheless, § 271(a) makes any subsequently developed process for making or using a patented product subject to the product's patent.³⁸

It has been argued that a third circumstance where blocking patents may occur is when an inventor makes a broad claim to an entire class (or genus) of products after producing only a single member of the class (or species). Several commentators have urged that the broad claim to the genus should be allowed if the species produced by the inventor was the only species in the genus that was known at the time the inventor filed the patent, and that the

35. *Id.* at 809–10 (citation omitted).

36. *See* *Invitrogen Corp. v. Clontech Lab., Inc.*, 429 F.3d 1052, 1071 (Fed. Cir. 2005) ("Enablement does not require the inventor to foresee every means of implementing an invention at pains of losing his patent franchise."). *See also* *Amgen Inc. v. Hoechst Marion Roussel, Inc.*, 314 F.3d 1313, 1335 (Fed. Cir. 2003) ("[T]he law makes clear that the specification need teach only one mode of making and using a claimed composition." (quoting *Amgen, Inc. v. Hoechst Marion Roussel, Inc.*, 126 F. Supp. 2d 69, 160 (D. Mass. 2001)); *Johns Hopkins Univ. v. CellPro, Inc.*, 152 F.3d 1342, 1361 (Fed. Cir. 1998); *Engel Indus., Inc. v. Lockformer Co.*, 946 F.2d 1528, 1533 (Fed. Cir. 1991) ("The enablement requirement is met if the description enables any mode of making and using the claimed invention.").

37. *See* *Invitrogen*, 429 F.3d at 1071.

38. *See* 35 U.S.C. § 271(a) (2006) (noting that there is no restriction to processes known or claimed).

patent should then dominate subsequent nonobvious inventions of other species within the claimed genus.³⁹ The scope of the claim to the genus would grow over time as new species were invented to populate the genus.

This third circumstance appears to conflict with the reward theory for patent protection. Under the traditional view, the patent system operates under a reward theory in which an inventor is given an exclusive right to practice an invention in order to capture returns from the investment in research and development in exchange for full disclosure of the invention so that the public may use the invention after expiration of the patent's term.⁴⁰

Edmund Kitch has challenged this traditional view with an alternative theory that he named the "prospect theory."⁴¹ Under the prospect theory, the scope of a patent should extend beyond what the inventor accomplished to cover improvements to the invention that are later developed by others.⁴² Professor Kitch argued that the prospect theory would enhance public welfare by allowing unified control over the development of the invention to the original inventor, thereby providing the original inventor with greater incentives to make investments without fear that the fruits of the invention will be appropriated by competitors.⁴³ Thus, this prospect theory offers a rationale for extending the scope of a patent beyond the inventor's disclosure in the patent application.

In a recent line of decisions, however, the Court of Appeals for the Federal Circuit appears to have significantly narrowed the permissible scope of patents to their disclosures.⁴⁴ It would seem a likely consequence of the Federal

39. See ROBERT PATRICK MERGES & JOHN FITZGERALD DUFFY, *PATENT LAW AND POLICY: CASES AND MATERIALS* 295–97 (4th ed. 2007); Collins, *supra* note 24, at 532; Lemley, *supra* note 12, at 1009; Merges, *supra* note 24.

40. The Supreme Court provided the following synopsis of the reward theory in *Universal Oil Products Co. v. Globe Oil & Refining Co.*:

As a reward for inventions and to encourage their disclosure, the United States offers a seventeen-year monopoly to an inventor who refrains from keeping his invention a trade secret. But the *quid pro quo* is disclosure of a process or device in sufficient detail to enable one skilled in the art to practice the invention once the period of the monopoly has expired; and the same precision of disclosure is likewise essential to warn the industry concerned of the precise scope of the monopoly asserted.

322 U.S. 471, 484 (1944).

41. Edmund W. Kitch, *The Nature and Function of the Patent System*, 20 J.L. & ECON. 265, 266 (1977).

42. *Id.* at 275–76.

43. *Id.*

44. See *Sitrick v. Dreamworks, LLC*, 516 F.3d 993 (Fed. Cir. 2008); *Auto. Techs. Int'l, Inc. v. BMW of N. Am., Inc.*, 501 F.3d 1274 (Fed. Cir. 2007); *Liebel-Flarsheim Co. v. Medrad, Inc.*, 481 F.3d 1371 (Fed. Cir. 2007); *Lizardtech, Inc. v. Earth Res. Mapping, Inc.*, 424 F.3d 1336 (Fed. Cir. 2005); *Chiron Corp. v. Genentech, Inc.*, 363 F.3d 1247 (Fed. Cir. 2004); *Plant Genetic Sys. N.V. v. DeKalb Genetics Corp.*, 315 F.3d 1335 (Fed. Cir. 2003); see also *Wyeth v. Mylan Pharmaceuticals, Inc.*, No. 1:07CV91, 2009 WL 3335062, at *9 (N.D. W.Va. Oct. 14, 2009)

Circuit's restriction of the patents' scopes to their disclosures would be to narrow the possibilities for blocking patents for improvements to the first and second circumstances described above and to eliminate the third circumstance where an inventor could make a valid claim to a genus containing species that the inventor did not invent.

This Article begins in Part I by tracing the historical background of blocking patents. Part II sets out the enablement, written description, and nonobviousness requirements for patentability. Part III analyzes the most recent example of a blocking patent that has been upheld by the Federal Circuit—the epic polypropylene case that was litigated over three decades. Part IV discusses the recent line of decisions from the Federal Circuit. This is followed by a brief conclusion.

I. HISTORICAL BACKGROUND OF BLOCKING PATENTS

The history of blocking patents in the United States appropriately begins with the following provision from the Patent Act of 1793:

[A]ny person, who shall have discovered an improvement in the principle of any machine, or in the process of any composition of matter, which shall have been patented, and shall have obtained a patent for such improvement, he shall not be at liberty to make, use or vend the original discovery, nor shall the first inventor be at liberty to use the improvement⁴⁵

The Supreme Court examined this provision in *Evans v. Eaton*,⁴⁶ a case involving a patent on an improved version of a machine used for manufacturing flour called a Hopperboy. The plaintiff contended that the patent was for the whole of the improved Hopperboy, or alternatively, for only the improvement in the Hopperboy that the plaintiff developed.⁴⁷ The Court first determined that the plaintiff was not entitled to a patent on the whole of the improved Hopperboy because the plaintiff's invention consisted of only an addition to the previous embodiment of the Hopperboy.⁴⁸ The Court then decided that the plaintiff was not entitled to a patent on his improvement of the Hopperboy because he had not specified what his improvement was on the invention.⁴⁹ The plaintiff described the whole of the improved Hopperboy, but

(following the line of Federal Circuit decisions); *Int'l Automated Sys., Inc. v. Digital Persona, Inc.* 565 F. Supp. 2d 1276, 1305 (D. Utah 2008).

45. Act of Feb. 21, 1793, ch. 11, § 2, 1 Stat. 318, 321, *repealed by* Act of July 4, 1836, ch. 357, § 20, 5 Stat. 117, 125.

46. 20 U.S. (7 Wheat.) 356 (1822).

47. *Id.* at 357.

48. *Id.* at 430–31. *See also* *Woodcock v. Parker*, 30 F. Cas. 491, 492 (C.C.D. Mass. 1813) (No. 17, 971) (noting that unless the patentee invented a whole new machine, the patent should be confined to the improvement).

49. 20 U.S. (7 Wheat.) at 432–35.

the Court ruled that he must describe his own improvement in order to obtain a patent on the improvement.⁵⁰

Congress repealed the explicit provision for blocking patents in 1836,⁵¹ and has never reenacted it. Nevertheless, courts continued to recognize the principle that an original patent could block the practice of a patent on an improvement to the invention in the original patent.⁵² The earliest published decision with such a holding is probably *Woodworth v. Rogers*.⁵³ Although *Woodworth* was decided in 1847, it relied on the Act of 1793, which had been repealed over a decade before, for the proposition that “no one can make an improvement on [a patented invention] . . . while the original term, or renewals of it, exist, without the license of the original patentee.”⁵⁴ *Star Salt Caster Co. v. Crossman*⁵⁵ followed *Woodworth* and involved an agreement allocating royalties between the owner of a patent on an original invention and the owner of a patent on an improvement to the original invention. In enforcing the agreement, the court stated:

Two patents of the kind may both be valid where the second is an improvement upon the first, in which event, if the second includes the first, neither can lawfully use that of the other without the other’s consent. Plainly the second patent could not be used without the consent of the owner of the first, nor could the owner of the first patent use the second without the consent of the owner, as the patent contains an invention which the owner of the first patent never made.⁵⁶

In *Cochrane v. Deemer*,⁵⁷ the Supreme Court held that the defendants infringed a patent on a process for making flour, even though the defendants made improvements to the patented process that might themselves have been patentable.⁵⁸ The Court concluded that the patented invention was “at the bottom of” the defendants’ improvements, and the defendants could not appropriate the patent “even though [the patented invention was] supplemented by and enveloped in very important and material improvements of their own.”⁵⁹

50. *Id.*

51. Act of July 4, 1836, ch. 357, § 20, 5 Stat. 117, 125.

52. See William Redin Woodward, *Definiteness and Particularity in Patent Claims*, 46 MICH. L. REV. 755, 767–68 (1948).

53. 30 F. Cas. 581 (C.C.D. Me. 1847) (No. 18,018).

54. *Id.* at 583.

55. 22 F. Cas. 1132 (C.C.D. Mass. 1878) (No. 13,321).

56. *Id.* at 1135.

57. 94 U.S. 780 (1876).

58. *Id.* at 787.

59. *Id.*

The Supreme Court next addressed the relationship between original and improvement patents in *Cantrell v. Wallick*.⁶⁰ The defendants contended that the patent was invalid because the invention was not entirely novel, but instead was an improvement on an earlier patented invention.⁶¹ Rejecting this argument, the Court explained:

Two patents may both be valid when the second is an improvement on the first, in which event, if the second includes the first, neither of the two patentees can lawfully use the invention of the other without the other's consent.

Therefore, letters patent for an improvement on a patented invention cannot be declared void because they include such patented invention.⁶²

In *Herman v. Youngstown Car Manufacturing Co.*,⁶³ the trial court relied on the fact that the defendant obtained a license for a patent on an improvement in concluding that the company did not infringe a patent on an original invention.⁶⁴ In reversing, the Sixth Circuit Court of Appeals explained that the trial court's reasoning was based on a fundamental error: "A patent is not the grant of a right to make or use or sell. It does not, directly or indirectly, imply any such right. It grants only the right to exclude others."⁶⁵ The appellate court continued by noting that many patents are granted in a field that a prior generic or basic patent covers, and that these patents are tributary to the prior patent and cannot be practiced without a license from the owner of the prior patent.⁶⁶ The court also explained that even though the issuance of an improvement patent indicates that there is a patentable difference between the improvement and original invention, the existence of a patentable difference does not preclude infringement, because the improvement could still be based on the original invention.⁶⁷

Besides *Cochrane* and *Cantrell*, the Supreme Court has dealt with the subject of blocking patents in only one other case—*Temco Electric Motor Co. v. Apco Manufacturing Co.*⁶⁸ In *Temco*, the plaintiff was the assignee of a patent issued to Ralph and William Thompson for shock absorbers on motor vehicles.⁶⁹ The Thompson patent involved combining relatively high frequency coiled springs with the relatively low frequency leaf springs that

60. 117 U.S. 689 (1886).

61. *Id.* at 694.

62. *Id.* (citation omitted).

63. 191 F. 579 (6th Cir. 1911).

64. *Id.* at 584.

65. *Id.*

66. *Id.* at 584–85.

67. *Id.* at 585.

68. 275 U.S. 319 (1928).

69. *Id.* at 322.

were originally built into motor vehicles.⁷⁰ See Figure 1 below.⁷¹ Because the coiled springs and leaf springs oscillated at different frequencies, their oscillations interfered with each other, and together the two springs quickly absorbed vibrations from the road.⁷²

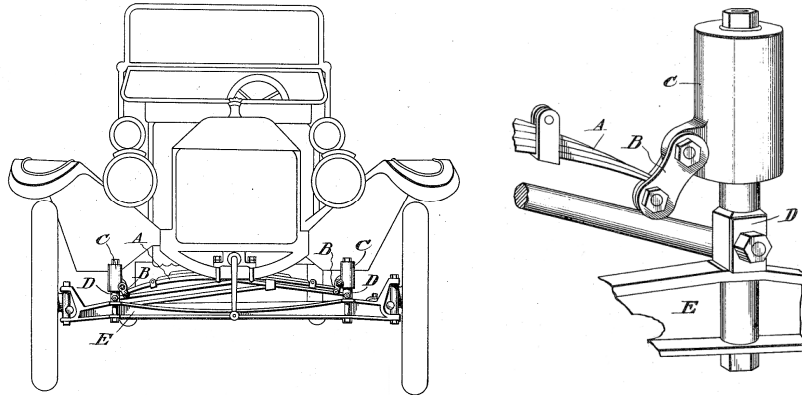

Figure 1. The Thompson Patent⁷³

Initially, the Thompson shock absorbers experienced success, but after several years, it became clear that the coiled springs wore out due to friction between the springs and the casings in which they moved when an uneven load tilted the vehicle body.⁷⁴ To solve this problem, Thompson added a pivot so that the leaf springs and vehicle body could tilt without affecting the vertical orientation of the coiled springs.⁷⁵ See Figure 2 below.⁷⁶ The Thompsons applied for a patent for this improvement to their shock absorbers, but the Patent Office determined in an interference proceeding that William Storrie had priority on account of a patent application filed five years and five months after the issuance of the original Thompson patent.⁷⁷ The Patent Office therefore issued the patent for the improvement to Storrie.⁷⁸ Storrie licensed

70. *Id.*; U.S. Patent No. 1,072,791 (filed Oct. 10, 1912), available at <http://patft.uspto.gov/netahtml/PTO/srchnum.htm> (enter "1,072,791" in search prompt and then follow "Images" hyperlink).

71. '791 Patent.

72. *Temco*, 275 U.S. at 322–23.

73. '791 Patent.

74. *Temco*, 275 U.S. at 324–25.

75. *Id.* at 324; U.S. Patent No. 1,279,035 (filed March 18, 1918), available at <http://patft.uspto.gov/netahtml/PTO/srchnum.htm> (enter "1,279,035" in search prompt and then follow "Images" hyperlink).

76. '035 Patent.

77. *Temco*, 275 U.S. at 321–22, 325.

78. *Id.* at 325.

his patent to the defendant, and the defendant raised the license from Storrie as a defense in the plaintiff's action for infringement of the Thompson patent.⁷⁹ Citing *Cochrane* and *Cantrell*, the Supreme Court rejected this defense: "It is well established that an improver cannot appropriate the basic patent of another, and that the improver without a license is an infringer, and may be sued as such."⁸⁰

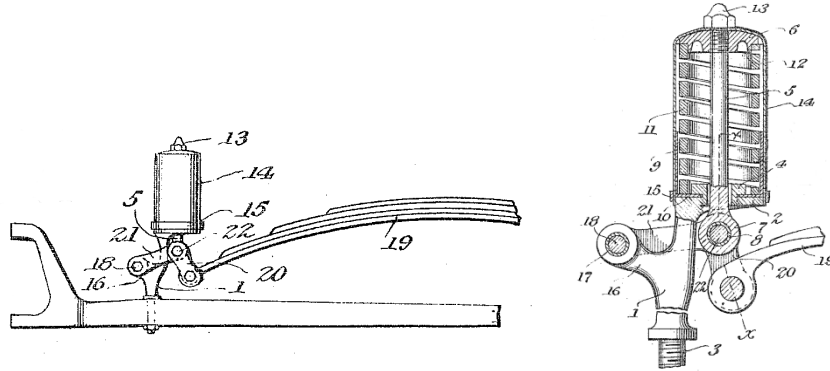

Figure 2. The Storrie Patent⁸¹

A comparison of the Thompson patent in Figure 1 with the Storrie patent in Figure 2 shows that they fit within the category of blocking patents where the improvement is a combination of a component with the earlier invention. In this case, Storrie combined the pivot on the rod inside the coiled springs to the shock absorbers in the Thompson patent. Furthermore, having the Thompson patent dominate the Storrie patent seems appropriate from an economic standpoint because the Thompsons' contribution to automotive technology was surely more significant than Storrie's contribution. Of course, before the addition of the pivot, the Thompson shock absorbers wore out after several years, but the Thompsons made the fundamental advance, while Storrie's improvement was less significant.⁸² It is less clear what payoffs the Thompsons and Storrie would have needed in order to recover the costs they incurred in making their respective discoveries, but since the Thompsons also applied for a patent on the Storrie improvement, it appears that the Thompsons incurred the improvement costs as well.⁸³ Accordingly, it seems appropriate that the Thompsons should have been allocated the greater share of the profits from the invention of the shock absorbers.

79. *See id.* at 325, 328.

80. *Id.* at 328.

81. '035 Patent.

82. *Temco*, 275 U.S. at 324–25.

83. *Id.*

After *Temco*, federal courts followed the principle that a patent on an original patent could block the practice of a patent on an improvement. For example, the Second Circuit Court of Appeals recognized the possibility of blocking patents in *New Jersey Zinc Co. v. Singmaster*:⁸⁴ “The prior patentee cannot use the improvement without the consent of the improver, and the latter cannot use the original invention without the consent of the former.”⁸⁵ In *Wine Railway Appliance Co. v. Baltimore & O.R. Co.*,⁸⁶ the Fourth Circuit dealt with a patent on an improvement consisting of an additional element combined with a prior patented invention.⁸⁷ The court ruled that “it is perfectly well settled that a device which embodies the principles of a basic patent as well as one for an improvement infringes both.”⁸⁸ The Fifth Circuit declared in *Zachos v. Sherwin-Williams Co.*⁸⁹ that “an improver must respect the rights of the patent on which he improves,”⁹⁰ and affirmed a judgment finding that the owner of a patent on a modification that may have been a slight improvement over the original invention infringed the patent on the original invention.⁹¹

The Federal Circuit has also recognized the possibility of blocking patents on improvements.⁹² In *Milliken Research Corp. v. Dan River, Inc.*,⁹³ the court commented, “We, of course, agree . . . that one may not be able to practice the invention protected by a patent directed to an improvement of another’s patented article or method except with a license under the latter.”⁹⁴ The court expressed the same principle in mathematical terms in *Atlas Powder Co. v. E.I. du Pont De Nemours & Co.*,⁹⁵ stating, “Du Pont concedes that, if Atlas patents A + B + C and Du Pont then patents the improvement A + B + C + D, Du Pont is liable to Atlas for any manufacture, use, or sale of A + B + C + D because the latter directly infringes claims to A + B + C.”⁹⁶ The court in *Texas Instruments, Inc. v. United States International Trade Commission*⁹⁷ similarly remarked, “Devices that have been modified to such an extent that the

84. 71 F.2d 277 (2d Cir. 1934).

85. *Id.* at 279.

86. 78 F.2d 312 (4th Cir. 1935).

87. *Id.* at 313–14.

88. *Id.* at 315–16.

89. 164 F.2d 234 (5th Cir. 1947).

90. *Id.* at 235.

91. *Id.* at 234–35.

92. *See, e.g.*, *Milliken Research Corp. v. Dan River, Inc.*, 739 F.2d 587 (Fed. Cir. 1984).

93. *Id.*

94. *Id.* at 594.

95. 750 F.2d 1569 (Fed. Cir. 1984).

96. *Id.* at 1580. The Federal Circuit upheld the trial court’s findings that there was no literal infringement but that there was infringement under the doctrine of equivalents. *Id.*

97. 805 F.2d 1558 (Fed. Cir. 1986).

modification may be separately patented may nonetheless infringe the claims of the basic patent.”⁹⁸

While recognizing blocking cases on improvements, these cases did not address either the enablement requirement for the original patents or the nonobviousness requirement for the improvement patents.⁹⁹ The enablement and written description requirements may place significant limitations on the scope of claims in an original patent, and the nonobviousness requirement may limit the validity of an improvement patent. Consequently, these requirements may affect whether an improvement patent infringes an original patent. The following section discusses the enablement, written description, and nonobviousness requirements for blocking patents.

II. THE ENABLEMENT, WRITTEN DESCRIPTION, AND NONOBVIOUSNESS REQUIREMENTS

The requirement that a patent specification must include a description sufficient to enable a person skilled in the art to make and use the invention has been a part of the patent law since the first patent statute of 1790.¹⁰⁰ In 1847, the Supreme Court ruled that, as a result of this requirement, a patent for a new composition of matter would be void if the specification only identified the substances that were to be combined without stating their relative proportions, or if it stated the proportions ambiguously.¹⁰¹ Otherwise, “no one could use the invention without first ascertaining by experiment the exact proportion of the different ingredients required to produce the result intended to be obtained.”¹⁰²

Several years later, the Supreme Court applied the enablement requirement to limit the permissible scope of patent claims in *O’Reilly v. Morse*,¹⁰³ which involved Samuel Morse’s patent for the telegraph.¹⁰⁴ The Supreme Court upheld the patent’s first seven claims, which referenced the description of the

98. *Id.* at 1563. For additional cases recognizing blocking patents on improvements, see 5 DONALD S. CHISUM, CHISUM ON PATENTS § 16.02 [1][a] (2009).

99. *Atlas Powder* did discuss enablement of the claims in the original patent and decided that the enablement requirement was satisfied for them. *Atlas Powder Co. v. E.I. du Pont De Nemours & Co.*, 750 F.2d 1569, 1576–77 (Fed. Cir. 1984). The improvement, however, did not literally infringe those claims. *Id.* at 1579. Instead, the court found infringement under the doctrine of equivalents, and it ruled that the enablement requirement was not applicable to infringement under the doctrine of equivalents. *Id.* at 1580–81. Consequently, the court did not address whether the defendant’s improvement was enabled by the specification in the original patent. *Id.*

100. Act of April 10, 1790, ch. 7, § 2, 1 Stat. 109, 110–11 (repealed 1793).

101. *Wood v. Underhill*, 46 U.S. (5 How.) 1, 5 (1847).

102. *Id.*

103. 56 U.S. (15 How.) 63 (1853).

104. *Id.* at 64.

invention in the specification, and it affirmed the lower court's injunction for infringement of them.¹⁰⁵ The Court also decided, however, that the eighth claim was void for failure to satisfy the enablement requirement.¹⁰⁶ In this last claim, the patent sought to cover not only the particular invention described in the specification, i.e. the telegraph, but also all improvements on it.¹⁰⁷ The claim read:

I do not propose to limit myself to the specific machinery or parts of machinery described in the foregoing specifications and claims; the essence of my invention being the use of the motive power of the electric or galvanic current, which I call electro-magnetism, however developed for making or printing intelligible characters, letters, or signs, at any distances, being a new application of that power of which I claim to be the first inventor or discoverer.¹⁰⁸

This claim would have covered future technologies, such as radio and television, which Morse had not invented. The Court held that the patentee claimed "what he has not described in the manner required by law," and that "a patent for such a claim is as strongly forbidden by the act of Congress, as if some other person had invented it before him."¹⁰⁹

The enablement requirement also limited the permissible scope of claims in *Consolidated Electric Light Co. v. McKeesport Light Co.*,¹¹⁰ which involved a patent for incandescent lights issued to William E. Sawyer and Albon Man.¹¹¹ The specification described the invention as using an incandescent conductor consisting "of carbon made from a vegetable fibrous material" inside a transparent sealed vessel from which oxygen was excluded.¹¹² The patent had four claims, two of which are relevant here.¹¹³ The first claim was for "[a]n incandescing conductor for an electric lamp, of carbonized fibrous or textile material, and of an arch or horseshoe shape, substantially as hereinbefore set forth."¹¹⁴ The third claim was for "[t]he incandescing conductor for an electric lamp, formed of carbonized paper, substantially as described."¹¹⁵ The specification also said that in the practice of the invention,

105. *Id.* at 112.

106. *Id.* at 113, 117.

107. *Id.* at 112.

108. *O'Reilly*, 56 U.S. (15 How.) at 112.

109. *Id.* at 120.

110. 159 U.S. 465 (1895).

111. *Id.* at 465–66.

112. *Id.* at 466.

113. *Id.* at 468.

114. *Id.* at 468.

115. *Electric Light*, 159 U.S. at 468.

the inventors had used carbonized paper and wood carbon of varying shapes and contours.¹¹⁶

The plaintiff alleged that the defendant infringed the first claim by using an incandescent light bulb supplied by the Edison Electric Company that had an incandescent conductor made of bamboo.¹¹⁷ The Supreme Court decided that the first claim violated the enablement requirement because it was overbroad.¹¹⁸ It reasoned that the permissible scope of a claim depended on how generic the relevant characteristic was over the range of the claim.¹¹⁹ The Court explained:

If, for instance, minerals or porcelains had always been used for a particular purpose, and a person should take out a patent for a similar article of wood, and woods generally were adapted to that purpose, the claim might not be too broad, though defendant used wood of a different kind from that of the patentee. But if woods generally were not adapted to the purpose, and yet the patentee had discovered a wood possessing certain qualities, which gave it a peculiar fitness for such purpose, it would not constitute an infringement for another to discover and use a different kind of wood, which was found to contain similar or superior qualities.¹²⁰

The Court pointed out that Thomas Edison discovered that a particular species of bamboo optimally served as an incandescent conductor in a light bulb only after testing many types of plants over a period of several months.¹²¹ It concluded that the specification did not enable persons skilled in the art to practice the invention over the range of the first claim without a substantial amount of experimentation, because the specification did not disclose which fibrous or textile materials were suitable for use as an incandescent conductor.¹²²

The issue of the permissible scope of claims often arises with respect to patents on chemical compositions where an inventor discovered one or more particular compositions (i.e. species) and seeks to obtain a broader patent on a category (i.e. a genus) of chemical compositions. For example, in *Corona Cord Tire Co. v. Doan Chemical Corp.*,¹²³ the patented invention was a process for vulcanizing rubber more rapidly using a particular chemical, diphenylguanidine.¹²⁴ The patent included claims involving not only diphenylguanidine, but also the class of chemicals called disubstituted

116. *Id.* at 467.

117. *See id.* at 468.

118. *See id.* at 472.

119. *See id.*

120. *Electric Light*, 159 U.S. at 472.

121. *Id.* at 472–73.

122. *See id.* at 475–76.

123. 276 U.S. 358 (1928).

124. *Id.* at 365.

guanidines, which included not only diphenylguanidine but also between fifty and one-hundred other chemicals.¹²⁵ Following *Consolidated Electric Light*, the Supreme Court held that the claims for the class of disubstituted guanidines was invalid, because the patentee made no showing that there was “any general quality common to disubstituted guanidines which made them all effective” for use in the process of the invention.¹²⁶ The Court pointed out that a number of the chemicals in the class that was claimed were not effective.¹²⁷ In addition, other members of the class had been discovered and used to accelerate the process of vulcanizing rubber before the filing of the patent application.¹²⁸

Corona Cord Tire suggests that a patentee must show that every species in a class must have the characteristics needed for use in the invention in order for the patentee to claim the genus. But courts have not required such a showing as long as the specification is sufficient to enable a person of ordinary skill in the art to make and use the invention over the range of the claim without “undue experimentation.”¹²⁹ *In re Ellis* provides an example.¹³⁰ The invention, a type of paint remover, contained solvents belonging to a class of chemicals called ketonic derivatives of cyclic CH₂ hydrocarbons.¹³¹ The Patent Office sought to limit the claims to a particular solvent within the class,¹³² but the Court of Appeals for the District of Columbia allowed the patent to extend to the entire class.¹³³ The court held that the specification with its enumeration of numerous chemicals in the class was “sufficient to convey to one skilled in the art the nature of the chemicals which will accomplish the desired result.”¹³⁴ It distinguished *Consolidated Electric Light* by explaining that the chemicals in the designated class had the common quality of being solvents and were suitable for use in the invention.¹³⁵

Similarly, in *In re Angstadt*,¹³⁶ the Court of Customs and Patent Appeals upheld a claim for a process that involved using catalysts selected from a class of chemicals.¹³⁷ The specification disclosed forty examples of species that were tested out of thousands of species of chemicals within the genus, and the

125. *See id.* at 385.

126. *Id.* at 385.

127. *See id.*

128. *Corona Cord Tire*, 276 U.S. at 382–83, 385.

129. *See, e.g., In re Gray*, 309 F.2d 769, 774 (C.C.P.A. 1962).

130. 37 App. D.C. 203 (1911). For additional discussion of *Ellis*, see C. H. Biesterfeld, *Breadth and Scope of Chemical Claims*, 2 J. PAT. OFF. SOC'Y 598, 602–05 (1919).

131. *Ellis*, 37 App. D.C. at 204–05.

132. *Id.*

133. *Id.* at 207.

134. *Id.*

135. *See id.* at 208–09.

136. 537 F.2d 498 (C.C.P.A. 1976).

137. *Id.* at 499, 501.

specification also stated that some of the species would not work in the process.¹³⁸ The court explained that the process in the invention was not complicated, and therefore, a person skilled in the particular art could take the specification with its forty examples and readily determine which of the species within the scope of the claims would work and which would not.¹³⁹ The court held that a person of ordinary skill in the art could practice the invention over the range of the claims without undue experimentation, and that the key word was “undue,” rather than “experimentation.”¹⁴⁰

In contrast, the Court of Appeals for the Federal Circuit decided in *Amgen, Inc. v. Chugai Pharmaceutical Co. Ltd.*¹⁴¹ that a claim for the genus of all the DNA sequences for proteins that were sufficiently duplicative of a particular protein with 165 amino acids was invalid for lack of enablement.¹⁴² The court noted that the patentee had made only fifty to eighty examples of the millions of possible DNA sequences that could be within the genus, and after five years of experimentation, the plaintiff was not able to determine which of the millions of possible DNA sequences actually were within the claim.¹⁴³ The court distinguished *Angstadt* on the grounds that the patentee had not provided “a disclosure sufficient to enable one skilled in the art to carry out the invention commensurate with the scope of his claims,” which in the context of DNA sequences meant “disclosing how to make and use enough sequences to justify grant of the claims sought.”¹⁴⁴

As the court explained in *Genentech Inc. v. Novo Nordisk*,¹⁴⁵ enablement requires more than “[t]ossing out the mere germ of an idea” or “vague intimations of general ideas that may or may not be workable.”¹⁴⁶ The specification does not have to include a working example¹⁴⁷ or disclose what would already be known to those skilled in the art,¹⁴⁸ but it does need to provide enough information to enable persons skilled in the art to carry out the

138. *Id.* at 205.

139. *Id.* at 503.

140. *Id.* at 503–04.

141. 927 F.2d 1200 (Fed. Cir. 1991).

142. *Id.* at 1203, 1212–13.

143. *Id.*

144. *Id.* at 1213. See also *In re Goodman*, 11 F.3d 1046, 1050 (Fed. Cir. 1993) (noting a single example in specification for producing one mammalian protein in one plant species did not provide sufficient information to enable broad claims for producing any type of mammalian protein in any plant species); *In re Vacek*, 947 F.2d 488, 495–96 (Fed. Cir. 1991) (discussing the disclosure of nine genera of cyanobacteria in specification with working example for only one species did not enable claim for all 150 genera of cyanobacteria).

145. 108 F.3d 1361 (Fed. Cir. 1997).

146. *Id.* at 1366.

147. *In re Borkowski*, 422 F.2d 904, 908 (C.C.P.A. 1970).

148. *Genentech*, 108 F.3d at 1366.

invention without undue experimentation.¹⁴⁹ The Federal Circuit has noted that whether a specification requires undue experimentation to practice an invention depends on the following factors:

(1) the quantity of experimentation necessary, (2) the amount of direction or guidance presented, (3) the presence or absence of working examples, (4) the nature of the invention, (5) the state of the prior art, (6) the relative skill of those in the art, (7) the predictability or unpredictability of the art, and (8) the breadth of the claims.¹⁵⁰

In addition to requiring a patent specification to enable a person of skill in the art to make and use the invention as claimed, the Federal Circuit also requires the specification to include a written description of the invention.¹⁵¹ One major purpose of the written description requirement is to establish that the patent applicant had possession of what the applicant claimed as the invention on the date of filing the application.¹⁵² Another purpose is to prevent an applicant from amending claims and have the claims relate back to an earlier filing date in order to gain priority of invention over a competing applicant.¹⁵³

There is a large amount of overlap between the written description and enablement requirements, because a written description of the invention will often enable a person of skill in the art to make and use the invention. Nevertheless, the Federal Circuit has noted the following distinctions between the two requirements:

[A]n invention may be described without an enabling disclosure of how to make and use it. A description of a chemical compound without a description of how to make and use it, unless within the skill of one of ordinary skill in the art, is an example. Moreover, an invention may be enabled even though it has

149. *Id.* at 1365.

150. *In re Wands*, 858 F.2d 731, 737 (Fed. Cir. 1988).

151. For a summary of the historical background of the written description requirement, see *In re Barker*, 559 F.2d 588, 591–93 (C.C.P.A. 1977).

152. See *Falko-Gunter Falkner v. Inglis*, 448 F.3d 1357, 1366 (Fed. Cir. 2006); *Capon v. Eshhar*, 418 F.3d 1349, 1357 (Fed. Cir. 2005); *Enzo-Bichem, Inc. v. Gen-Probe Inc.*, 323 F.3d 956, 969 (Fed. Cir. 2002); *Vas-Cath Inc. v. Mahurkar*, 935 F.2d 1555, 1563–64 (Fed. Cir. 1991); see also *In re Ruschig*, 379 F.2d 990, 995–96 (C.C.P.A. 1967). But see Timothy R. Holbrook, *Possession in Patent Law*, 59 SMU L. REV. 123, 161–63 (2006) (arguing that possession of the invention should be established through proof of enablement rather than the written description requirement).

153. *Chiron Corp. v. Genentech, Inc.*, 363 F.3d 1247, 1255 (Fed. Cir. 2004) (“The written description requirement prevents applicants from using the amendment process to update their disclosures (claims or specifications) during their pendency before the patent office.”); see also *Gentry Gallery, Inc. v. Berkline Corp.*, 134 F.3d 1473, 1479 (Fed. Cir. 1998); Robert P. Merges, *Software and Patent Scope: A Report from the Middle Innings*, 85 TEX. L. REV. 1627, 1651–56 (2007) (urging that the written description requirement should be limited to “misappropriation by amendment” cases such as *Gentry Gallery*).

not been described. Such can occur when enablement of a closely related invention A that is both described and enabled would similarly enable an invention B *if* B were described. A specification can likewise describe an invention without enabling the practice of the full breadth of its claims.¹⁵⁴

Because the enablement requirement relies on what would be apparent to persons skilled in the art, it closely parallels the modern standard for nonobviousness. As provided in 35 U.S.C. § 103, an invention is not patentable “if the differences between the subject matter sought to be patented and the prior art are such that the subject matter as a whole would have been obvious at the time the invention was made to a person having ordinary skill in the art to which said subject matter pertains.”¹⁵⁵

Before § 103 was adopted in 1952, however, the standard for patentability revolved around the concept of invention, which was described as “inherently elusive,”¹⁵⁶ and it appeared to evolve over time.¹⁵⁷ In an early case, *Hotchkiss v. Greenwood*,¹⁵⁸ the Supreme Court ruled that a patent for an improved doorknob made of clay, rather than wood or metal, was invalid because it involved merely the substitution of a known material for others.¹⁵⁹ It held:

[U]nless more ingenuity and skill . . . were required . . . than were possessed by an ordinary mechanic acquainted with the business, there was an absence of that degree of skill and ingenuity which constitute essential elements of every invention. In other words, the improvement is the work of the skilful mechanic, not that of the inventor.¹⁶⁰

The emphasis in *Hotchkiss* on “invention” as a requirement for patentability caused confusion in the courts and created uncertainty in the applicability of this standard for patentability.¹⁶¹

154. *Univ. of Rochester v. G.D. Searle & Co.*, 358 F.3d 916, 921–22 (Fed. Cir. 2004) (citation omitted).

155. 35 U.S.C. § 103(a) (2006).

156. *Great Atl. & Pac. Tea Co. v. Supermarket Equip. Corp.*, 340 U.S. 147, 151 (1950); *see also* Giles S. Rich, *The Vague Concept of “Invention” as Replaced by Sec. 103 of the 1952 Patent Act*, 46 J. PAT. OFF. SOC’Y 855, 859–62 (1964) (noting vagueness of the “requirement for invention” that evolved out of *Hotchkiss v. Greenwood*).

157. Edmond W. Kitch, *Graham v. John Deere Co.: New Standards for Patents*, 1966 SUP. CT. REV. 293, 303 (1966).

158. 52 U.S. (11 How.) 248 (1850).

159. *Id.* at 262.

160. *Id.* at 267.

161. *See McClain v. Ortmyer*, 141 U.S. 419, 427 (1891) (“The truth is the word [invention] cannot be defined in such a manner as to afford any substantial aid in determining whether a particular device involves an exercise of the inventive faculty or not.”); *Monroe Auto Equip. Co. v. Heckethorn Mfg. & Supply Co.*, 332 F.2d 406, 410 (6th Cir. 1964) (“It is virtually a practical impossibility to define adequately that abstraction which we call invention.”); *Trabon Eng’g Corp. v. Dirkes*, 136 F.2d 24, 27 (6th Cir. 1943) (“Long experience with assailed inventions in trial and on review led us in humility to the conclusion that the inventive concept is an abstraction

By tying it directly to the knowledge of a person having ordinary skill in the art, § 103 clarified the standard for patentability. As a consequence, the scope of enablement for the patent for an original invention (i.e. that which is within the skill of one of ordinary skill in the art) closely tracks the scope of patentability for an improvement to the original invention under the nonobvious requirement (i.e., whether the differences between the improvement and the original invention would have been obvious to a person having ordinary skill in the art). Since a person having ordinary skill in the art is presumed to have known of the specification for the original invention,¹⁶² there would seem to be little room for a patent on an improvement to be both within the scope of enablement for the patent on the original invention and nonobvious.

One possibility might be that the scope of patentability for an improvement could extend beyond what is nonobvious on account of the doctrine of equivalents. The doctrine of equivalents arose to prevent a fraud on a patent by a copyist making insubstantial changes to a patented invention to take it outside of the literal scope of its claims.¹⁶³ A device is typically infringing under the doctrine of equivalents “if it performs substantially the same function in substantially the same way to obtain the same result”¹⁶⁴ as a patented invention, even though the device and patented invention may “differ in name, form, or shape.”¹⁶⁵ The Supreme Court has noted, “An important factor [in determining equivalency] is whether persons reasonably skilled in the art would have known of the interchangeability of an ingredient not contained in the patent with one that was.”¹⁶⁶

Even with the doctrine of equivalents, though, the scope of patent protection for an original invention generally should not extend to cover nonobvious improvements. The purpose of the doctrine of equivalents is to cover insignificant modifications of the original invention that do not

impossible to define”); *Picard v. United Aircraft Corp.*, 128 F.2d 632, 639 (2d Cir. 1942) (“‘Invention,’ for patent purposes, has been difficult to define. Efforts to cage the concept in words have proved almost as unsuccessful as attempts verbally to imprison the concept ‘beautiful.’”); *Warren Telechron Co. v. Waltham Watch Co.*, 91 F.2d 472, 473 (1st Cir. 1937) (“The quality which constitutes invention is indefinable, as has often been said. . . . It is a matter of feeling rather than of logic.”).

162. See, e.g., *In re GPAC Inc.*, 57 F.3d 1573, 1579 (Fed. Cir. 1995) (“The person of ordinary skill in the art is a hypothetical person who is presumed to know the relevant prior art.”); *Kimberly-Clark Corp. v. Johnson & Johnson*, 745 F.2d 1437, 1453 (Fed. Cir. 1984) (“[I]t is the hypothetical person of ordinary skill in the art who is referred to in § 103 of the 1952 Patent Act who must be presumed to have, or is charged with having, knowledge of all material prior art.”).

163. See *Graver Tank & Mfg. Co. v. Linde Air Prods. Co.*, 339 U.S. 605, 607 (1950).

164. *Id.* at 608 (quoting *Sanitary Refrigerator Co. v. Winters*, 280 U.S. 30, 42 (1929)).

165. *Id.* at 608 (quoting *Union Paper-Bag Mach. Co. v. Murphy*, 97 U.S. 120, 125 (1877)).

166. *Id.* at 609 (quoted in *Warner-Jenkinson Co. v. Hilton Davis Chem. Co.*, 520 U.S. 17, 25 (1997)).

substantially affect its function or the way the invention, as modified, accomplishes its results.¹⁶⁷ Generally, an improvement based upon such changes would be obvious to persons of skill in the art and would therefore not qualify for a patent. For example, in *Graver Tank & Manufacturing Co. v. Linde Air Products Co.*, the Court found that the defendant's substitution of manganese for magnesium in the patented welding flux was infringing under the doctrine of equivalents.¹⁶⁸ The Court emphasized that persons familiar with welding fluxes were aware, and the chemical literature confirmed, that manganese could be substituted for magnesium in welding fluxes.¹⁶⁹ It is therefore inconceivable that the defendant in *Graver Tank* could have obtained a patent for a welding flux with manganese that would have satisfied the nonobviousness requirement.

The doctrine of equivalents, however, may extend the scope of patent protection to cover not only unclaimed variations of an original invention that were well known at the time the patent was filed, such as the welding flux in *Graver Tank*, but also after-arising technologies.¹⁷⁰ Although after-arising technologies may not be within the present grasp of persons of ordinary skill in the art, persons of ordinary skill in the art may have the capability of adapting present inventions to after-arising technologies when they eventually come on-line.

For example, the Federal Circuit upheld claims to reach after-arising technology in *Superguide Corp. v. DirecTV Enterprises, Inc.*¹⁷¹ The claims in issue were for interactive television program guides that allowed viewers to search through a large volume of broadcasted television information without having to wait for the information to scroll down to them on their television screens.¹⁷² The claims involved mixing a "regularly received television signal" with search instructions from television viewers through a remote control

167. *Id.* at 607–09.

168. 339 U.S. 605 (1950).

169. *Id.* at 612.

170. See *Smithkline Beecham Corp. v. Excel Pharm., Inc.*, 356 F.3d 1357, 1364 (Fed. Cir. 2004) (designating after-arising technologies as a "quintessential example of an enforceable equivalent").

171. 358 F.3d 870 (Fed. Cir. 2004). For additional decisions stating that claims may cover after-arising technology, see *Innogenetics, N.V. v. Abbott Laboratories*, 512 F.3d 1363, 1371–72 (Fed. Cir. 2008) ("Our case law allows for after-arising technology to be captured within the literal scope of valid claims that are drafted broadly enough."); *Bd. of Trs. of Leland Stanford Junior Univ. v. Roche Molecular Sys., Inc.*, 528 F. Supp. 2d 967, 981 (N.D. Cal. 2007) ("The claims can therefore be construed to cover later developed technology that was unavailable but known at the time of the invention."). See also *Laser Alignment, Inc. v. Woodruff & Sons, Inc.*, 491 F.2d 866, 873 (7th Cir. 1974) (finding that a patent for using a narrow collimated beam of light to lay sewer pipe was infringed by a device that used a laser even though lasers did not exist when the patent application was filed).

172. *Superguide*, 358 F.3d at 873.

system and a microprocessor.¹⁷³ The claims did not specify whether the television signals were in analog or digital format, but the trial court ruled that the claims were limited to analog television signals, because analog television signals were the only type of television signals that were broadcast at the time the patent was filed.¹⁷⁴ The Federal Circuit reversed, giving the claims a broad construction that included both analog and digital signals, combinations of them, and even signals in other formats.¹⁷⁵ The Federal Circuit observed that although analog was the dominant format for television signals at the time of filing, persons of skill in the art were aware then that video data could be communicated in either analog or digital format.¹⁷⁶ While the *Superguide* decision was concerned with claim interpretation and did not expressly address enablement, it would seem that the enablement requirement would also have been satisfied, since the specification would have enabled persons of ordinary skill in the art to adapt the invention to a digital format.

Similarly, in *Hughes Aircraft Co. v. United States*,¹⁷⁷ the Federal Circuit ruled that a patent for an apparatus controlling the velocity and orientation of a satellite was infringed under the doctrine of equivalents.¹⁷⁸ The claims stated that the apparatus included means for sending data of the satellite's location and orientation to an external source and means for receiving control signals from the external source to alter the satellite's velocity and orientation.¹⁷⁹ At the time of filing of the patent application, computers were too large to be placed on satellites.¹⁸⁰ Nevertheless, the Federal Circuit held that a satellite using a later developed on-board computer for controlling the satellite's velocity and orientation was infringing because it performed "the same function in substantially the same way to obtain the same result" as the apparatus described in the patent.¹⁸¹ The Federal Circuit noted that once on-board computers became available, any intelligent engineer could adapt the apparatus described in the patent to using them for controlling the satellite.¹⁸² The improvement of using an on-board computer in the original patent would not have been patentable, because the improvement would have been obvious

173. *Id.* at 875.

174. *Id.* at 876–77.

175. *Id.* at 878.

176. *Id.* at 879. The specification also did not differentiate between analog and digital signals, but instead referred to regular received television signals as "video data." *Id.*

177. 717 F.2d 1351 (Fed. Cir. 1983).

178. *Id.* at 1366.

179. *Id.* at 1355.

180. *See id.* at 1364–65 (noting on-board computers required time to be developed).

181. *Id.* at 1365. *See also* *Datascope Corp. v. SMEC, Inc.*, 776 F.2d 320, 326 (Fed. Cir. 1985) ("[A]n embellishment' made possible by technological advances may not permit an accused device to escape 'the web of infringement.'").

182. *Hughes Aircraft*, 717 F.2d at 1364–65.

to a person of ordinary skill in the art once on-board computers became available. Therefore, there could not be blocking patents between the original invention and the improvement.

Even though the doctrine of equivalents permits a finding of infringement beyond the scope of a patent's claims, it will not provide an opportunity for blocking patents to arise because improvements within the range of the doctrine of equivalents will not be patentable. The range of the doctrine of equivalents is limited to variations that must perform the same function in substantially the same way to obtain the same result. These variations would be obvious to persons of ordinary skill in the art, however, with respect to after-arising technology.¹⁸³

Another possible way in which the claims of a patent might be able to extend to nonobvious after-arising technology involves the timing of enablement.¹⁸⁴ A line of cases have ruled that the enablement requirement was satisfied with respect to species that were within the scope of a claim to a genus and were unknown at the time of the filing of a patent application so long as the specification enabled all the species in the genus that were known at the time of filing.¹⁸⁵ These cases produced the paradigm example of blocking patents in recent times. They arose out of the invention of crystalline polypropylene in the early 1950s and the epic litigation that came in its wake. The next section examines the polypropylene litigation and the paradoxical

183. In *Atlas Powder Co. v. E.I. du Pont De Nemours & Co.*, the Federal Circuit held: "It is not a requirement of equivalence, however, that those skilled in the art know of the equivalence when the patent application is filed or the patent issues. That question is determined as of the time infringement takes place." 750 F.2d 1569, 1581 (Fed. Cir. 1984). The court did not suggest, however, that an improvement within the range of the doctrine of equivalents would satisfy the nonobviousness requirement for patentability at the time that the improvement was first developed. Rather, its ruling only addressed whether the improvement would have been known to those skilled in the art at the times that the patent was filed and issued. *Id.*

184. See Hugh McTavish, *Enabling Genus Patent Claims to DNA*, 2 MINN. INTELL. PROP. REV. 121, 139 n.118 (2001) ("Blocking patents arise because of [the] point in time at which enablement is judged.").

185. *United States Steel Corp. v. Phillips Petroleum Co.*, 865 F.2d 1247, 1252 (Fed. Cir. 1989) ("[C]ertainly, the disclosure of specifics adds to the understanding one skilled in the art would glean from a generic term, but it does not follow that such added disclosure limits the meaning thereof.") (citation omitted); *Standard Oil v. Montedison S.p.A.*, 664 F.2d 356, 362 (3d Cir. 1981) ("Generally, in determining entitlement to a patent when there are contending inventors, priority is awarded to the party who first reduced to practice a conception of the invention if all other conditions of patentability are satisfied."); *In re Hogan*, 559 F.2d 595, 606 (C.C.P.A. 1977) (noting patents of a subsequent improvement should not be "utilize[d] . . . to 'reach back' and preclude or invalidate a patent on the underlying invention"); *Phillips Petroleum Corp. v. U.S. Steel Corp.*, 673 F. Supp. 1278, 1357 (D. Del. 1987) ("It is the burden of an alleged infringer not merely to demonstrate that it is better but to demonstrate that it is in fact a different product. Defendants have wholly failed to do this."); *Standard Oil v. Montedison S.p.A.*, 494 F. Supp. 370, 374-76 (D. Del. 1980).

principle that permits unknown species within a genus to be deemed enabled even though the patent's specification does not enable a person of ordinary skill in the art to find them.¹⁸⁶

III. THE POLYPROPYLENE LITIGATION

A. *The Chemistry of Polypropylene*

Polypropylene is one of the three most widely used plastics.¹⁸⁷ Approximately 41.5 million metric tons of polypropylene are produced annually worldwide with an estimated value of \$66 billion.¹⁸⁸ The United States consumes 16% of the world's supply and has the second largest share of the market after China.¹⁸⁹ Its many desirable properties account for the large amount of its production. Polypropylene is not only inexpensive but it is also rugged, fairly lightweight, easily molded, translucent, retains its shape after being deformed, and has a relatively high melting point compared to other plastics.¹⁹⁰ Polypropylene has its own resin identification code for recycling:¹⁹¹



Like other plastics, polypropylene is made up of large chain-like molecules called polymers, which are formed by bonding together many¹⁹² smaller molecules called monomers.¹⁹³ Polypropylene is formed from molecules of propylene, which is a colorless odorless gas that is not only highly flammable, but also is an asphyxiant.¹⁹⁴ Propylene is found in coal gas but is mostly

186. See MERGES & DUFFY, *supra* note 39, at 295 (discussing “enablement and the temporal paradox”).

187. CHARLES E. CARRAHER JR., *INTRODUCTION TO POLYMER CHEMISTRY* 199 (2007). The others are polyethylene and polyvinyl chloride. *Id.* at 12. See also Phillips, 673 F. Supp. at 1317 (“Crystalline polypropylene is one of the most widely used chemical compositions in commerce today.”).

188. Andrea Borruso, *CEH Marketing Research Report Abstract: Polypropylene Resins*, CHEMICAL INDUSTRIES NEWSL. (SRI Consulting, Menlo Park, Cal.), Sept. 2007, at 7, available at <http://www.sriconsulting.com/nl/Public/2007Sep.pdf>. This amounts to over twelve pounds for every person on Earth. *Id.*

189. *Id.*

190. *Id.*

191. The Unicode, Inc., *Miscellaneous Symbols Range: 2600-26FF*, THE UNICODE STANDARD VERSION 5.2, at 240 (2009).

192. “Poly” is derived from the Greek word for “many.”

193. Polymer, in 9 *ENCYCLOPEDIA BRITANNICA* 580 (15th ed. 2007).

194. Industrial Polymers, in 23 *ENCYCLOPEDIA BRITANNICA* 315, 733–34 (15th ed. 2007).

carbon chain, while some of them are below the chain. Molecules of polypropylene in which the methyl groups are randomly arranged above and below the carbon chain are called atactic polypropylene.²⁰¹ Prior to the early 1950s, the only form of polypropylene that had been produced was amorphous polypropylene, which is formed from atactic molecules of polypropylene.²⁰² Amorphous polypropylene is a liquid at room temperature,²⁰³ and therefore does not exhibit the useful qualities of polypropylene as we know it today.

In isotactic polypropylene all the methyl groups are arranged on the same side of the central carbon atom chain, as shown below.²⁰⁴ Formation of isotactic polypropylene is achieved through the use of particular catalysts that control the orientation of the propylene molecules as they are lined up in the polymer chain.²⁰⁵

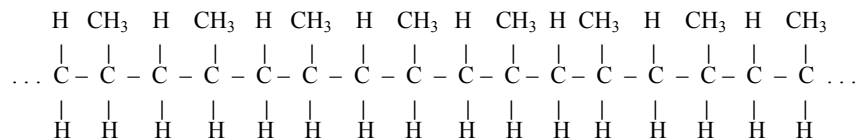

Figure 5. Isotactic Polypropylene

With all the methyl groups on the same side of the central carbon chain, the molecules coil up into helixes and then the molecules are able to form crystals as shown in the microphotograph of crystalline polypropylene below.²⁰⁶ When the crystals form, the polypropylene molecules pack together into a tight, regular array called a crystal lattice.²⁰⁷

201. The terms “atactic” and “isotactic” originated with Giulio Natta’s wife, Rosita Natta, who happened to be a language scholar and semanticist. Karl Ziegler, *Consequences and Development of an Invention*, in NOBEL LECTURES, CHEMISTRY 1963–1970 12 (1972); FRANK M. McMILLAN, THE CHAIN STRAIGHTENERS: FRUITFUL INNOVATION: THE DISCOVERY OF LINEAR AND STEREOREGULAR SYNTHETIC POLYMERS 127 (1979).

202. *Phillips*, 673 F. Supp. at 1316. The amorphous polypropylene was also tree-branched, rather than arranged in a linear chain. *Id.*

203. *Standard Oil v. Montedison S.p.A.*, 494 F. Supp. 370, 416 (D. Del. 1980) (“In the polymerization of propylene over commonly used catalysts, such as phosphoric acid and nickel on silica-alumina, the polymer produced is liquid and contains little, if any, solid polymer.”).

204. MAIER & CALAFUT, *supra* note 199, at 4.

205. *Id.*

206. *Phillips*, 673 F. Supp. at 1286.

207. *Id.*

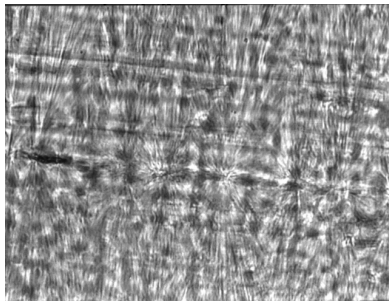

Figure 6. Microphotograph of Polypropylene

The formation of the crystal lattice has a “very profound effect upon the physical properties” of the polypropylene.²⁰⁸ The ordered arrangement of the crystal lattice causes the polypropylene to become a solid up to its melting point of 320° F and imparts strength to the material.²⁰⁹ The attractive forces in the crystal lattice also make the polypropylene impervious to solvents and acids that would otherwise cause it to dissolve.²¹⁰

The synthesis of crystalline polypropylene was a major scientific achievement. The discovery is described in the *Encyclopedia Britannica* as follows:

It is generally accepted that isotactic polypropylene was discovered in 1954 by the Italian chemist Giulio Natta and his assistant Paolo Chini, working in association with Montecatini (now Montedison SpA) and employing catalysts of the type recently invented by Karl Ziegler for synthesizing polyethylene. (Partly in recognition of this achievement, Natta was awarded the Nobel Prize for Chemistry in 1963 along with Ziegler.)²¹¹

B. *The Natta Patent*

Karl Ziegler was a prominent German professor who was the director of the Max Planck Institute for Coal Research in Mülheim, Germany.²¹² After two decades of research on organic compounds of metals, Professor Ziegler discovered during World War II an Aufbau (“growth”) reaction in which a particular metal-organic compound induced the growth of linear chains of

208. *Id.*

209. *Id.* at 1286–87 (internal citations omitted).

210. *Id.*

211. *Industrial Polymers, Major*, in 21 ENCYCLOPEDIA BRITANNICA 315 (15th ed. 2007).

212. *Biography Karl Ziegler*, in NOBEL LECTURES, CHEMISTRY, *supra* note 201, at 25.

ethylene molecules.²¹³ This research eventually led to his synthesis of polyethylene, another major plastic, in 1953.²¹⁴

Giulio Natta was professor and director of the Department of Industrial Chemistry at the Milan Polytechnic, and his area of research was hydrocarbon chemistry.²¹⁵ After hearing a lecture by Professor Ziegler in 1952, Professor Natta realized that the catalysts that Ziegler had discovered could be used to produce linear chains from other organic compounds.²¹⁶ Natta arranged with the Montecatini Chemical Company, Italy's largest chemical company, to invite Ziegler to a meeting in Milan to discuss his research.²¹⁷ That meeting led to an agreement in which Montecatini purchased rights for the commercial development of Ziegler's research in Italy and Natta was given access to Ziegler's research.²¹⁸ The research and licensing agreement between Ziegler and Montecatini also provided for three of Natta's research assistants (nicknamed the "Three Bright Boys") to visit Ziegler's laboratory in Mülheim, Germany beginning in February of 1953.²¹⁹ Natta's research assistants followed the synthesis of polyethylene in Professor Ziegler's laboratory in 1953.²²⁰

Paolo Chini was one of these research assistants.²²¹ After returning to Milan, he repeated certain experiments that Ziegler described in his German patent, and was struck by the ease with which he was able to polymerize ethylene using a particular mixture of catalysts (which are now known as the Ziegler-Natta catalysts).²²² On March 11, 1954, Natta instructed Chini to use the same catalysts with propylene, whereupon Chini reported that he had produced solid polypropylene.²²³ Further experiments were conducted in the spring of 1954, and Natta forwarded them to the Patent Department at

213. MCMILLAN, *supra* note 201, at 38–39; PETER J.T. MORRIS, *POLYMER PIONEERS* 22, 79 (1986).

214. Professor Ziegler drafted his own patent application for producing polyethylene, titled "Process of the Polymerization of Ethylene," and he filed it with the German Patent Office on November 17, 1953. HEINZ MARTIN, *POLYMERS, PATENTS, PROFITS: A CLASSIC CASE STUDY FOR PATENT INFIGHTING: KARL ZIEGLER, THE TEAM, 1953-1998* 14 (2007).

215. NOBLE LECTURES, *supra* note 201, at 63; MCMILLAN, *supra* note 201, at 53.

216. MORRIS, *supra* note 213, at 82; Giulio Natta, *From the Stereospecific Polymerization to the Asymmetric Autocatalytic Synthesis of Macromolecules*, in NOBLE LECTURES, CHEMISTRY, *supra* note 201, at 28.

217. MORRIS, *supra* note 213, at 82.

218. MCMILLAN, *supra* note 201, at 54.

219. *Id.* at 95.

220. MARTIN, *supra* note 214, at 13–14.

221. MCMILLAN, *supra* note 201, at 95.

222. The Ziegler-Natta catalysts are a mixture of various chemicals, which include titanium tetrachloride and triethyl aluminum. *Id.*

223. MARTIN, *supra* note 214, at 21; MCMILLAN, *supra* note 201, at 95.

Montecatini.²²⁴ On June 8, 1954, Montecatini filed a patent application claiming the polymerization of propylene with the Italian Patent Office that named Natta as the sole inventor.²²⁵ On December 10, 1954, Natta submitted a paper describing his discovery of crystalline polypropylene to the *Journal of the American Chemical Society*, and the paper was published on March 20, 1955.²²⁶

C. *The Hogan and Banks Patent*

Although Ziegler and Natta were the first to synthesize polypropylene, and shared the 1963 Nobel Prize for doing so, the Phillips Petroleum Company was awarded a blocking patent in the United States that was given priority over Montecatini's patent.²²⁷ In 1951, J. Paul Hogan and Robert L. Banks were chemists working in the research laboratory at Phillips Petroleum on converting petroleum gases into gasoline.²²⁸ One of their experiments involved passing propylene through a one-inch tube packed with a catalyst to which a chromium salt had been added.²²⁹ The experiment failed because their tube became clogged with a waxy substance.²³⁰ A similar effect had been observed by chemists at Shell Development Corporation, who were trying to develop synthetic rubber during World War II; but the Shell chemists thought the substance they observed was a nuisance, and they abandoned their experiment.²³¹ In contrast, Hogan and Banks were able to persuade Phillips's management to allow them to investigate the mysterious substance.²³² Hogan and Banks conducted a series of experiments in their laboratory using a catalyst composed of a support of silica and alumina impregnated with chromium oxide that eventually became known as the Marlex catalyst.²³³ "On

224. MARTIN, *supra* note 214, at 23.

225. *Id.* Professor Ziegler's laboratory produced polypropylene shortly afterwards, and Professor Ziegler sent Professor Natta a sample. Professor Ziegler was shocked to learn a few days later that Professor Natta's laboratory had already polymerized propylene. *Id.*; MCMILLAN, *supra* note 201, at 104. A compromise was eventually worked out in which Professor Ziegler and Montecatini divided the licensing royalties from polypropylene 70/30. *Id.* at 105.

226. Giulio Natta et al., *Crystalline High Polymers of α -Olefins*, 77 J. AM. CHEM. SOC'Y 1708 (1955); *See also* Phillips Petroleum Corp. v. U.S. Steel Corp., 673 F. Supp. 1278, 1338 (D. Del. 1987).

227. MORRIS, *supra* note 213, at 23 ("[W]hile legal priority for the discovery of stereoregular polypropylene has been granted to Phillips Petroleum, the scientific honors—as evidenced by the joint award of the 1963 Noble Prize—belong to Karl Ziegler and Giulio Natta.").

228. MCMILLAN, *supra* note 201, at 69–70.

229. *Id.*

230. *Id.* Hogan and Banks described the substance as a "heavy waxy polymer" and a "unique solid material" with a "tacky, latex-like nature." *Phillips*, 673 F. Supp. at 1337.

231. MCMILLAN, *supra* note 201, at 69–70.

232. *See* CARRAHER, *supra* note 187, at 199.

233. *See id.*

March 14, 1952, [they] submitted a Disclosure of Invention [form] to the Phillips Patent Department . . . [describing their invention as] a ‘process for the production of propylene polymers’, ‘improved polymer products from propylene, 1-butene and other monoalkylethylenes’ and a ‘new catalyst for polymerization.’”²³⁴ The Patent Department requested additional information, and on November 26, 1952, Hogan provided the characteristics for the solid polypropylene that he had produced:

melting point °F:	240–280
density:	0.90–0.95
intrinsic viscosity:	0.2–1.0
weight average molecular weight:	5,000–20,000. ²³⁵

The Hogan and Banks patent application, entitled “Solid Polymers of Olefins,”²³⁶ was filed on January 27, 1953.²³⁷ The application contained the information that Hogan provided concerning melting point and average molecular weight.²³⁸ Unlike Natta’s patent application, the Hogan and Banks application failed to identify the polypropylene as crystalline, and it did not describe the mechanism for the formation of isotactic polypropylene in terms of aligning the methyl groups on the same side of the central carbon chain.²³⁹

The Assistant Director of Research at Phillips, Dr. William Reynolds, became aware of Natta’s article in the *Journal of the American Chemical Society* shortly after its publication.²⁴⁰ Although the article did not identify the catalysts that Natta used, Reynolds was able to speculate what they were—and he suggested that Phillips should investigate the Ziegler-Natta process.²⁴¹ Chemists at Phillips conducted experiments with the Ziegler-Natta catalysts in the spring of 1955, and succeeded in producing crystalline polypropylene in May and June.²⁴² While these experiments were conducted, Reynolds

234. *Phillips*, 673 F. Supp. at 1337.

235. *Id.*

236. *In re Hogan*, 559 F.2d 595, 597 (C.C.P.A. 1977). Olefin is a term used for alkenes, which are hydrocarbons with at least one carbon to carbon double bond. Alkenes have the general formula C_nH_{2n} and include ethylene (C_2H_4) as well as propylene (C_3H_6). L.G. WADE, JR., *ORGANIC CHEMISTRY* 279 (Nicole Folchetti ed., Pearson Prentice Hall 6th ed. 2006); G.P. Moss et al., *Glossary of Class Names of Organic Compounds and Reactive Intermediates Based on Structure (IUPAC Recommendations 1995)*, 67 *PURE & APPLIED CHEMISTRY* 1307, 1313 (1995).

237. *Phillips*, 673 F. Supp. at 1284.

238. *Id.* at 1290.

239. *Id.* at 1286.

240. *Id.* at 1338.

241. *Id.*

242. *Phillips*, 673 F. Supp. at 1338.

observed: “The more I see of the so called Ziegler polymerization the more I am of the opinion that this process represents one of the most basic catalytic process discoveries in many years. The process is undoubtedly far more general and versatile than demonstrated for MARLEX.”²⁴³ Meanwhile, in the summer and fall of 1955, other chemists at Phillips were studying the polypropylene produced with the Marlex catalyst that Hogan and Banks had used.²⁴⁴ They determined that it was an isotactic polymer, but that it was brittle, because its highest molecular weight was around 30,000, and molecular weights above 50,000 were required for the polypropylene to be flexible.²⁴⁵

The Phillips chemists advised the Patent Department of their conclusions and also that others, including Natta, were claiming that they had invented crystalline polypropylene.²⁴⁶ Phillips then decided to file a new application²⁴⁷ in order to provoke an interference²⁴⁸ so that the United States Patent Office would determine which company had priority for the invention.²⁴⁹ While Phillips thought that its 1953 application described crystalline polypropylene, it was concerned that the word “crystalline” did not appear anywhere in the application.²⁵⁰ Therefore, on January 11, 1956, Phillips filed its continuation-in-part application²⁵¹ in which it included the claim: “Normally solid polypropylene consisting essentially of recurring propylene units, having a substantial crystalline polypropylene content.”²⁵² The 1956 application

243. *Id.* at 1339.

244. *Id.*

245. *Id.*

246. *Id.*

247. See 35 U.S.C. § 120 (2006) (stating that an inventor who has previously filed a patent application may file a new application while the first application is pending and obtain the benefit of the filing date of the first application for the new application if it contains a reference to the first application).

248. Interferences are governed by 35 U.S.C. § 135 (2006).

249. *Phillips*, 673 F. Supp. at 1339.

250. *Id.*

251. See 37 C.F.R. § 1.53(b)(2) (2008) (“A continuation-in-part application (which may disclose and claim subject matter not disclosed in the prior application) . . .”). Any new matter in the continuation-in-part application will not receive the priority date for the original application. See *Augustine Med., Inc. v. Gaymar Indus., Inc.*, 181 F.3d 1291, 1302 (Fed. Cir. 1999):

Subject matter that arises for the first time in the CIP [continuation-in-part] application does not receive the benefit of the filing date of the parent application. Thus, the decision on the proper priority date—the parent application date or the CIP application date—for subject matter claimed in a CIP application depends on when that subject matter first appeared in the patent disclosures. To decide this question, a court must examine whether the “disclosure of the application relied upon reasonably convey[s] to the artisan that the inventor had possession at that time of the later claimed subject matter.”

(citation omitted).

252. *Phillips*, 673 F. Supp. at 1286.

differed significantly from the 1953 application. In addition to adding references to crystalline polymers and crystalline polypropylenes, Phillips broadened the ranges of melting points from 240–300°F to 240–320°F, and the range of weight average molecular weights from 5000–20,000 to 900–50,000 and higher.²⁵³ In addition, Phillips added four descriptive examples of the invention to the application; the last example called for the use of the Ziegler-Natta catalysts—triethyl aluminum and titanium tetrachloride.²⁵⁴

On September 9, 1958, the United States Patent Office instituted and declared an interference to authorize the Board of Patent Interferences to determine which of five competing companies was entitled to priority of invention for crystalline polypropylene.²⁵⁵ Three decades of massive litigation then ensued. The 1960s were spent “in an incredibly involved program of discovery.”²⁵⁶ Finally, on November 29, 1971, after hearing testimony from 126 witnesses, the Board issued a 113-page decision²⁵⁷ awarding priority to Montedison for Natta’s patent.²⁵⁸ The litigation continued with the three losing parties filing civil actions to challenge the Board’s decision.²⁵⁹ If anything, the litigation seemed to become more acrimonious as the plaintiffs were permitted to amend their complaints to add charges, which had not been raised in the interference, that Montedison had committed fraud by deliberately misrepresenting and failing to disclose material facts in the filing and prosecution of its patent applications.²⁶⁰

After an eighty-five day trial, the district court issued a ninety-one-page decision awarding priority to Phillips for the invention of crystalline

253. *Id.* at 1340.

254. *Id.*

255. *Standard Oil Co. v. Montedison*, S.p.A., 540 F.2d 611, 613 (3d Cir. 1976). The five companies were Phillips Petroleum Company, Montedison, S.p.A. (the successor to Montecatini Chemical Company), E. I. DuPont de Nemours & Company, Standard Oil Company and Hercules, Inc. *Id.* at 614 n.4. The Board rendered judgment on the issue of priority against Hercules, Inc. on October 6, 1964. *Id.*

256. *Standard Oil Co. v. Montedison*, S.p.A., 398 F. Supp. 420, 423 (D. Del. 1975), *vacated*, 540 F.2d 611 (3d Cir. 1976). *See generally* *Montecatini Edison S.p.A. v. E. I. Du Pont de Nemours & Co.*, 434 F.2d 70 (3d Cir. 1970); *Natta v. Zletz*, 418 F.2d 633 (7th Cir. 1969); *In re Natta*, 410 F.2d 187 (3d Cir. 1969); *Natta v. Zletz*, 405 F.2d 99 (7th Cir. 1968); *Natta v. Hogan*, 392 F.2d 686 (10th Cir. 1968); *In re Natta*, 388 F.2d 215 (3d Cir. 1968); *Natta v. Zletz*, 379 F.2d 615 (7th Cir. 1967); *In re Hogan*, 309 F. Supp. 945 (D. Del. 1970); *In re Natta*, 48 F.R.D. 319 (D. Del. 1969); *Hogan v. Zletz*, 43 F.R.D. 308 (N.D. Okla. 1967); *In re Natta*, 264 F. Supp. 734 (D. Del. 1967); *In re Natta*, 259 F. Supp. 922 (D. Del. 1966).

257. *Standard Oil Co. v. Montedison*, S.p.A., 494 F. Supp. 370, 375 (D. Del. 1980).

258. *Standard Oil Co. v. Montedison*, S.p.A., 540 F.2d 611, 614 (3d Cir. 1976).

259. *Standard Oil Co. v. Montedison*, S.p.A., 431 F. Supp. 1064 (D. Del. 1977).

260. *Id.* at 1072. Plaintiffs were not allowed to add allegations of Montedison’s “brainwashing” or exerting improper influence on patent examiners, however. *Id.* at 1071.

polypropylene.²⁶¹ The district court determined the date of priority for Montedison to be June 8, 1954, which was the date that Natta filed his patent application with the Italian Patent Office.²⁶² Although Natta did not file his United States patent application until June 8, 1955, the United States patent application related back to the filing of the Italian patent application pursuant to 35 U.S.C. § 119, because Natta filed the United States patent application within one year of the filing of the Italian patent application.²⁶³

The district court based the date of priority for Phillips on the original filing of the Hogan and Banks patent application on January 27, 1953.²⁶⁴ While Phillips abandoned the 1953 patent application when it filed its continuation-in-part application on January 11, 1956, the date of priority for the continuation-in-part application related back to the date of the original patent application under 35 U.S.C. § 120 with respect to any disclosures made in the original patent application.²⁶⁵ In order for the 1956 continuation-in-part application to relate back to 1953, though, the 1953 disclosure would have to satisfy the enablement requirement for the invention.²⁶⁶ The Board of Patent Interferences had rejected the earlier date on the grounds that the 1953 patent application failed to disclose crystalline polypropylene and failed to disclose a utility for the material.²⁶⁷ The district court ruled, however, that the 1953 application satisfied the requirements for the 1956 continuation-in-part application to relate back to 1953,²⁶⁸ because the 1953 application disclosed four experiments that Hogan and Banks conducted which produced solid propylene polymers with a substantially crystalline polypropylene content.²⁶⁹

261. *Standard Oil Co. v. Montedison, S.p.A.*, 494 F. Supp. 370 (D. Del. 1980).

262. *Id.* at 386.

263. *See* 35 U.S.C. § 119 (2006).

264. *Standard Oil*, 494 F. Supp. at 411.

265. *See* 35 U.S.C. § 120 (2006). *See also supra* note 151 and accompanying text.

266. *See, e.g., Frazer v. Schlegel*, 498 F.3d 1283, 1287 (Fed. Cir. 2007) (“[W]hen reliance is on a patent document already filed, the question is whether the document discloses the invention of the count by meeting the written description and enablement requirements of 35 U.S.C. § 112 ¶ 1, for a filed application serves as a constructive reduction to practice of its content.”).

267. *Standard Oil Co. v. Montedison, S.p.A.*, 494 F. Supp. 370, 411 (D. Del. 1980).

268. *Id.* The district court stated “that the 1953 application was an adequate constructive reduction to practice.” *Id.* This is equivalent to saying that it satisfied the enablement requirement. *See Yasuko Kawai v. Metlesics*, 480 F.2d 880, 886 (C.C.P.A. 1973) (“It goes without saying that proof of a constructive reduction to practice would also require that the specification be sufficient to enable anyone skilled in the art to make the invention, i.e., the ‘how to make’ requirement of section 112 should also be met by the specification.”). The district also ruled that the 1953 satisfied the utility requirement for patentability because Phillips recognized that its crystalline polypropylene could be used as a wax modifier. *Standard Oil*, 494 F. Supp. at 411.

269. *Standard Oil*, 494 F. Supp. at 412–18.

On appeal, the Third Circuit affirmed.²⁷⁰ The appellate court began its analysis with the description of the invention in the interference count: “Normally solid polypropylene, consisting essentially of recurring propylene units, having a substantial crystalline polypropylene content.”²⁷¹ It then parsed the phrases in the interference count one at a time. Montedison and the other appellants “concede[d] that the 1953 application disclosed a solid polypropylene,” but challenged whether the polypropylene it disclosed consisted “essentially of recurring propylene units” and whether the polypropylene had “a substantial crystalline content.”²⁷² The 1953 application did not expressly state that the material produced in Hogan and Banks’ experiments consisted of recurring propylene units,²⁷³ but the district court concluded that the application inherently disclosed this fact.²⁷⁴ The appellate court decided that this conclusion was supported by expert testimony that a polymer chemist, in 1953, would have recognized that polypropylene produced under the conditions of their experiments would consist of essentially recurring propylene units.²⁷⁵ The appellate court similarly agreed with the district court’s conclusion that the 1953 application inherently disclosed that the polypropylene was crystalline.²⁷⁶ It ruled this conclusion was supported by expert testimony that a skilled polymer chemist would have concluded the material was crystalline after reading the information in the disclosure that the material was not soluble in pentane at room temperature, as well as the data provided concerning the material’s melting temperature, viscosity, density, and molecular weight.²⁷⁷

D. In re Hogan

While the courts were reviewing the massive interference over the invention of polypropylene, a significant ruling was made on a related patent. The original Hogan and Banks patent application included claims for not only polypropylene but also for a solid polymer of another hydrocarbon called 4-methyl-1-pentene (C₆H₁₂), which has the repeating chemical structure shown below.²⁷⁸

270. *Standard Oil Co. v. Montedison, S.p.A.*, 664 F.2d 356 (3d Cir. 1981).

271. *Id.* at 363.

272. *Id.* at 364.

273. *Id.*

274. *Id.* at 365.

275. *Standard Oil*, 664 F.2d at 366.

276. *Id.* at 371.

277. *Id.*

278. *In re Hogan*, 559 F.2d 595, 597 (C.C.P.A. 1977).

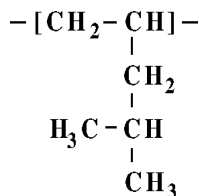
Figure 7. Structure of 4-methyl-1-pentene²⁷⁹

After the action to review the interference was filed in the district court, Phillips decided to divide the claims for polypropylene and 4-methyl-1-pentene into separate patent applications by filing divisional applications pursuant to 35 U.S.C. § 121 for the separate inventions.²⁸⁰ The Patent and Trademark Office (“PTO”) rejected claims 13–15 in the successor to the divisional application for 4-methyl-1-pentene.²⁸¹ Claim 13 was for “[a] normally solid homopolymer of 4-methyl-1-pentene,” and claims 14 and 15 were narrower dependent claims that incorporated claim 13 by reference.²⁸² Among the grounds that the patent examiner gave for rejecting these claims was that the claims for the polymer were broader than the scope of enablement, because they included other species of the polymer that were the subjects of subsequent patents.²⁸³ The Board of Patent Appeals affirmed the PTO’s rejection of the claims.²⁸⁴ Among the reasons given by the Board was that the disclosure in the original 1953 Hogan and Banks application was not enabling, because the disclosure was limited to making crystalline polymers but the claims the Board was rejecting “encompass[e] an amorphous polymer as well, which is manifestly outside the scope of the enabling teaching present in the case.”²⁸⁵

279. *Id.* at 597 n.4.

280. *Id.* at 597 n.3.

281. *Id.* at 597. After filing the divisional application in 1967, Phillips filed a continuation application to the divisional in 1971. *Id.* The rejected claims were actually in the 1971 continuation application, rather than the 1967 divisional application. *See id.*

282. *Id.* at 597–98.

283. *Hogan*, 559 F.2d at 600.

284. *Id.* at 601.

285. *Id.* The Board’s decision appears factually incorrect. Amorphous polymers were known in the prior art, and therefore, they did not need to be disclosed to enable a person of ordinary skill in the art to make them. The original 1953 application included references to patents from 1937 and 1945 for processes for producing amorphous polymers. *See also* U.S. Patent No. 2,085,525 (issued June 29, 1937); U.S. Patent No. 2,387,784 (issued Oct. 30, 1945). In addition, its specification identifies amorphous polymers as the prior art:

A further characteristic of polymers according to this invention is that they have relatively high densities as compared with the predominantly amorphous polymers produced by the prior art. Another characteristic of the polymers according to this invention is that they have relatively high melting points in comparison with prior art amorphous polymers.

U.S. Patent No. 4,342,854 col. 1 (issued Aug. 3, 1982).

On appeal to the Court of Custom and Patent Appeals,²⁸⁶ the court reversed the decision of the Board of Patent Appeals.²⁸⁷ The court ruled that the patent examiner and board erred by considering a later state of the art (i.e., patents filed after the filing of the 1953 application) to decide whether the claims satisfied the enablement requirement.²⁸⁸ The court reasoned:

The PTO has not challenged appellants' assertion that their 1953 application enabled those skilled in the art in 1953 to make and use "a solid polymer" as described in claim 13. Appellants disclosed, as the only then existing way to make such a polymer, a method of making the crystalline form. To now say that appellants should have disclosed in 1953 the amorphous form which on this record did not exist until 1962, would be to impose an impossible burden on inventors and thus on the patent system. There cannot, in an effective patent system, be such a burden placed on the right to broad claims. To restrict appellants to the crystalline form disclosed, under such circumstances, would be a poor way to stimulate invention, and particularly to encourage its early disclosure. To demand such restriction is merely to state a policy against broad protection for pioneer inventions, a policy both shortsighted and unsound from the standpoint of promoting progress in the useful arts, the constitutional purpose of the patent laws.²⁸⁹

The court appears to have envisioned the situation that claim 13 for a solid polymer covered two forms for it: a crystalline form that was enabled by the specification of the 1953 application and an amorphous form that was not enabled because it was discovered later.²⁹⁰ Since it seemed to the court that the amorphous form did not exist at the time of the patent application, the patentee could not have been expected to claim the amorphous form at that time.²⁹¹

These circumstances were distinguishable from those in *Consolidated Electric Light Co. v. McKeesport Light Co.*,²⁹² because the patentees in the latter case were aware when they filed their application that some types of carbon made from vegetable fibrous materials would not work in their

286. Before the creation of the Court of Appeals for the Federal Circuit in 1984, the Court of Customs and Patent Appeals handled appeals from the Board of Patent Appeals. See *Brenner v. Manson*, 383 U.S. 519, 527 (1966) ("Determinations of the Patent Office may be challenged either by appeal to the CCPA or by suit instituted in the United States District Court for the District of Columbia.").

287. *Hogan*, 559 F.2d at 607-08.

288. *Id.* at 604-07.

289. *Id.* at 606.

290. As pointed out in note 285, *supra*, the amorphous form of the polymer was within the prior art in 1953. Consequently, the amorphous form of 4-methyl-1-pentene did not have to be disclosed in the specification. It was, however, disclosed in the references in the 1953 application. Thus, the court appears to have been mistaken as to the state of the art in 1953. This does not affect the authoritativeness of its decision as precedent.

291. *Hogan*, 559 F.2d at 606.

292. 159 U.S. 465 (1895).

invention as well as the carbonized paper that they described in the specification, and also that there were other vegetable fibrous materials that they had not tested.²⁹³ In *Consolidated Electric Light Co.*, the broad claim for carbon made from a vegetable fibrous material did not satisfy the enablement requirement under the state of the art as that was known at the time of the filing of the patent application.²⁹⁴ In contrast, under the court's view of the circumstances in the *Hogan* case, the broad claim for a solid polymer did satisfy the enablement requirement under the state of the art as that was known at the time of the filing of the patent application, because the amorphous form was not yet known.²⁹⁵ It is not clear, however, why this distinction should make a difference. While Phillips may not have known that there was any difference between a claim for a solid polymer and a crystalline form for a solid polymer, because the existence of an amorphous polymer was not known at that time under the court's view of the state of the art in 1953, Phillips could have limited its claim to the crystalline form for the solid polymer, if that is what it disclosed in the specification.²⁹⁶

The *Hogan* decision continued:

Consideration of a later existing state of the art in testing for compliance with § 112, first paragraph, would not only preclude the grant of broad claims, but would wreak havoc in other ways as well. The use of a subsequently-existing improvement to show lack of enablement in an earlier-filed application on the basic invention would preclude issuance of a patent to the inventor of the thing improved, and in the case of issued patents, would invalidate all claims (even some "picture claims") therein. Patents are and should be granted to later inventors upon unobvious improvements. Indeed, encouragement of improvements on prior inventions is a major contribution of the patent system and the vast majority of patents are issued on improvements. It is quite another thing, however, to utilize the patenting or publication of later existing improvements to "reach back" and preclude or invalidate a patent on the underlying invention.²⁹⁷

The references to "broad claims" in this and the previously quoted paragraph suggest approval of Professor Kitch's prospect theory of patents.²⁹⁸ The court did not explain, however, why restricting the scope of protection to the disclosure in the specification "would be a poor way to stimulate invention, and particularly to encourage its early disclosure."²⁹⁹ As the concurring opinion by Judge Miller pointed out, the majority's decision to extend the

293. *Id.* at 472–74.

294. *Id.* at 476.

295. *Hogan*, 559 F.2d at 606.

296. *See id.*

297. *Id.*

298. *See supra* text accompanying notes 41–43.

299. *Hogan*, 559 F.2d at 606.

scope of protection to future technology would arguably impede rather than advance progress.³⁰⁰ Judge Miller explained that the effect of the majority's decision was to relegate future inventions to a subservient position with respect to the original invention merely because the inventor used a term that the inventor thought was limited to a single species, but later turned out to have a broader meaning.³⁰¹ In addition, the court did not explain why patent protection should extend to forms of materials that are unknown at the time of the filing of a patent, but not to any other forms of materials that a patentee might want to claim under a prospect theory of patents.³⁰²

Next, the court addressed concerns with invalidating a patent on enablement grounds because of the subsequent discovery of a product that it did not enable:

If applications were to be tested for enablement under § 112 in the light of a later existing state of the art, the question would arise over how much later. An examiner could never safely call a halt and pass an application to issue. One who had slavishly copied the disclosed and claimed invention of a patent issued in 1965, for example, could resist an infringement action by insisting that a court hold the patent invalid because it was not enabling with respect to some third product which first came into existence, and thus came within the purview of the claim, in 1975.³⁰³

The answer to this concern is that if future developments caused a claim to be overbroad, the patentee could obtain reissuance of the patent under § 251 and restrict the claim to the scope of enablement.³⁰⁴

Lastly, the court responded to the PTO's concern about the possibility of subsequent infringement actions against later inventors as follows:

The PTO position, that claim 13 is of sufficient breadth to cover the later state of the art (amorphous polymers) shown in the "references," reflects a concern that allowance of claim 13 might lead to enforcement efforts against the later developers. Any such conjecture, if it exists, is both irrelevant and unwarranted. The business of the PTO is patentability, not infringement. Like the judicially-developed doctrine of equivalents, designed to protect the patentee with respect to later-developed variations of the claimed invention,

300. *Id.* at 610 (Miller, J., concurring). *See* Scotchmer, *supra* note 1.

301. *Hogan*, 559 F.2d at 610.

302. *See id.* at 610–11.

303. *Id.* at 606–07.

304. *See* 35 U.S.C. § 251 (2006):

Whenever any patent is, through error without any deceptive intention, deemed wholly or partly inoperative or invalid . . . by reason of the patentee claiming more or less than he had a right to claim in the patent, the Director shall . . . reissue the patent for the invention disclosed in the original patent . . . for the unexpired part of the term of the original patent. *See also* O'Reilly v. Morse, 56 U.S. (15 How.) 62, 121 (1853) (permitting patentee to disclaim claim that did not satisfy the enablement requirement).

the judicially-developed “reverse doctrine of equivalents,” requiring interpretation of claims in light of the specification, may be safely relied upon to preclude *improper* enforcement against later developers. The courts have consistently considered subsequently existing states of the art as raising questions of infringement, but never of validity. It is, of course, a major and infinitely important function of the PTO to insure that those skilled in the art are enabled, as of the filing date, to practice the invention claimed. If, in the light of all proper evidence, the invention claimed be clearly enabled as of *that* date, the inquiry under § 112, first paragraph, is at an end.³⁰⁵

In his concurring opinion, Judge Miller characterized the majority as applying a double standard by interpreting claims in light of the state of the art at the time of filing for purposes of enablement, but interpreting them in light of the later state of the art for purposes of infringement.³⁰⁶ He urged that instead of employing a double standard, the PTO should simply interpret the claims in light of the state of the art at the time of filing to determine whether they satisfy the enablement requirement.³⁰⁷ Judge Miller reasoned that in the case of a claim for a solid homopolymer, if a person of ordinary skill in the art at the time of filing would have interpreted it to include both amorphous and crystalline forms, and only the crystalline form was enabled, then the claim should be rejected for extending beyond the scope of enablement.³⁰⁸ On the other hand, if a person of ordinary skill in the art would have interpreted the claim to include only the crystalline form, the claim should be allowed and limited to the crystalline form.³⁰⁹

The majority’s reliance on the reverse doctrine of equivalents to protect later developers from “*improper* enforcement”³¹⁰ is problematic. The reverse doctrine of equivalents arose in case law as a defense to an infringement action where a device came within the literal scope of a claim, but it was “so far changed in principle from a patented article that it perform[ed] the same or a similar function in a substantially different way”³¹¹ The Federal Circuit has described this defense, however, as an “anachronistic exception, long mentioned but rarely applied,”³¹² and it has never affirmed a decision in which

305. *Hogan*, 559 F.2d at 607 (footnotes omitted).

306. *Id.* at 610 (Miller, J., concurring).

307. *Id.*

308. *Id.* at 611.

309. *Id.* at 610–11.

310. *Hogan*, 559 F.2d at 607.

311. *Graver Tank & Mfg. Co. v. Linde Air Prods. Co.*, 339 U.S. 605, 608 (1950).

312. *Tate Access Floors, Inc. v. Interface Architectural Res., Inc.*, 279 F.3d 1357, 1368 (Fed. Cir. 2002).

the defense had succeeded at trial.³¹³ Moreover, the courts have not demarcated the limits of this defense clearly, if it actually still exists. Consequently, later developers cannot expect the same protection from the reverse doctrine of equivalents as they could expect from rigorous enforcement of the enablement requirement to limit the scope of claims to the disclosure in the specification as understood by a person of ordinary skill in the art.

The Court of Customs and Patent Appeals relied on the *Hogan* decision three years later in *In re Koller*.³¹⁴ In *Koller*, the patent examiner rejected a claim for a process of producing a desired chemical from a precursor chemical in which one of the steps involved mixing the precursor chemical with metal salts in a “liquid medium.”³¹⁵ Whether the claim was valid depended upon its priority date, and this issue turned on whether the patent application related back to the filing of the grandparent application, which also referred to mixing in a “liquid medium.”³¹⁶ The patent examiner based the claim’s rejection on the failure of the disclosure to enable a person of ordinary skill in the art to use solvents that were not miscible (i.e., capable of being mixed to form a single homogeneous substance) with water at the time the grandparent application was filed.³¹⁷ The court decided that the case paralleled *Hogan* because at the time the grandparent application was filed, a person of ordinary skill in the art would not have recognized that solvents which were not miscible with water would be suitable for the patented process.³¹⁸ Therefore, such a person would not have included them within the scope of the term “liquid medium.”³¹⁹ So under *Hogan*, the enablement requirement was satisfied, because the disclosure enabled mixing with the only types of solvents that were recognized at the time—i.e., solvents that would mix with water.³²⁰ The court thus reversed the decision of the Board of Appeals to affirm the examiner’s rejection of the claim.

E. Enforcement of the Hogan and Banks Patent

After the Third Circuit’s decision on the polypropylene interference proceeding, the Hogan and Banks patent issued on March 15, 1983, over twenty-seven years after the application was filed. The enforcement phase of the litigation then began with Phillips filing infringement actions against a

313. *Roche Palo Alto L.L.C. v. Apotex, Inc.*, 531 F.3d 1372, 1378 (Fed. Cir. 2008) (“The reverse doctrine of equivalents is rarely applied, and this court has never affirmed a finding of non-infringement under the reverse doctrine of equivalents.”).

314. *In re Koller*, 613 F.2d 819, 824–25 (C.C.P.A. 1980).

315. *Id.* at 820.

316. *Id.* at 821.

317. *Id.* at 821–22.

318. *Id.* at 824.

319. *Koller*, 613 F.2d at 824.

320. *Id.* at 825.

number of companies. After obtaining licenses from Phillips to settle the infringement actions, the infringement defendants filed an action against Phillips, seeking declaratory relief that the Hogan and Banks patent was invalid, not infringed, and unenforceable.³²¹ In an eighty-one page opinion, the district court held that the patent was valid and infringed.³²²

On the issue of enablement, the court observed that the infringement defendants did not dispute that the 1953 application enabled a person of ordinary skill in the art to make polypropylene that satisfied all the elements of its single claim: “Normally solid polypropylene consisting essentially of recurring propylene units, having a substantial crystalline polypropylene content.”³²³ The defendants argued, though, that the application did not describe or enable the entire class of compounds that came within the claim.³²⁴ Focusing on the intrinsic viscosity of 0.2 to 1.0 and the weight average molecular weight of 5000 to 20,000 given in the specification,³²⁵ the defendants asserted that the application disclosed only polypropylene that was useless as a plastic for commercial applications and “was little more than a low molecular weight, brittle laboratory curiosity.”³²⁶ They also contended that “the 1953 application does not enable one to produce the high molecular weight, tough polypropylenes of commerce.”³²⁷ Although the district court acknowledged that “some of the market success of crystalline polypropylene can be credited to higher molecular weights not attributable to the Hogan and Banks invention,”³²⁸ it ruled that the 1953 application satisfied the written description and enablement requirements.³²⁹ The opinion found that the defendants missed the point of the inquiry under § 112, which was to determine whether the “*claimed*” invention was described and enabled, and that it was not necessary for a patent applicant “to predict every possible variation, improvement or commercial embodiment of his invention.”³³⁰ The court explained that since the claim did not include any limitations regarding intrinsic viscosity or molecular weight, these factors were not relevant to the written description and enablement requirements.³³¹ It concluded that

321. Phillips Petroleum Corp. v. U.S. Steel Corp., 673 F. Supp. 1278, 1283 (D. Del. 1987). The declaratory relief action was consolidated with the original infringement actions against Hercules, Inc. and U.S. Steel. *Id.*

322. *Id.* at 1358.

323. *Id.* at 1286, 1292.

324. *Id.* at 1292.

325. *See supra* text accompanying note 235.

326. *Phillips*, 673 F. Supp. at 1290, 1318.

327. *Id.* at 1292.

328. *Id.* at 1318.

329. *Id.* at 1292.

330. *Id.* at 1292.

331. *Phillips*, 673 F. Supp. at 1292.

regardless of whether the defendants had a superior product to the polypropylene described in the 1953 application, it was still crystalline polypropylene that came within the claims of the patents.³³²

On appeal, the Federal Circuit affirmed the district court.³³³ The defendants argued that the claim was too broad because it embraced subject matter that lacked an adequate basis in the 1953 application.³³⁴ Relying on the *Hogan* and *Koller* cases, the Federal Circuit rejected the defendants' arguments:

Defendants' misdirected approach here is the same as that improperly relied upon by the PTO in *Hogan*. Defendants do not, as they cannot, argue that the 1953 specification fails to enable one skilled in the art to practice the *claimed invention*. That the '851 claim may cover a later version of the claimed composition (crystalline polypropylene [sic] with higher intrinsic viscosity and average molecular weight) relates to infringement, not to patentability. To hold differently would, in the words of *Hogan*, "impose an impossible burden on inventors and thus on the patent system."³³⁵

The appellate court continued, stating, "the central flaw [with] defendants' evidence . . . [was] that it was directed solely to a later state of the art."³³⁶ The appellate court also rejected the defendants' argument under the reverse doctrine of equivalents, saying that the defendants provided no legal basis or equitable grounds, and it saw none "for restricting the coverage of the claim to less than its admitted literal scope."³³⁷ With the Federal Circuit's decision, more than thirty years of polypropylene litigation came to an end.

Although the Federal Circuit did not explain its decision in these terms, the decision can be understood as an example of a blocking patent in which an improvement to a prior invention consists of a combination of a component with the prior invention.³³⁸ The essential difference between the polypropylene disclosed in the Hogan and Banks patent application and the higher molecular weight polypropylene made with the Ziegler-Natta catalysts was that the polypropylene made with the Ziegler-Natta catalysts had longer polypropylene chains. The longer polypropylene chains made with the Ziegler-Natta catalysts (i.e., A + B) were simply the product of combining shorter polypropylene chains (i.e., A) with additional polypropylene units (i.e., B). Thus, the manufacture of the higher molecular weight polypropylene with

332. *Id.* at 1357.

333. *U.S. Steel Corp. v. Phillips Petroleum Co.*, 865 F.2d 1247, 1254 (Fed. Cir. 1989).

334. *Id.* at 1250–51.

335. *Id.* at 1251–52 (citations and footnote omitted).

336. *Id.* at 1252.

337. *Id.* at 1253.

338. *See supra* text accompanying notes 25–27.

the Ziegler-Natta catalysts necessarily entailed infringement of the Hogan and Banks patent.

Nevertheless, the end result of allowing Phillips' patent to dominate Natta's is troubling from the standpoint of the most appropriate allocation of intellectual property rights. Natta's contribution surely was greater than that made by Hogan and Banks. Even today, most polypropylene is produced using the Ziegler-Natta catalysts.³³⁹ Because of its high molecular weight, the polypropylene produced with Ziegler-Natta catalysts has the toughness, flexibility, and other desirable characteristics that have made it a success in the marketplace. In contrast, the polypropylene produced with the Marlex catalysts described in the Hogan and Banks patent is brittle and has never been a successful commercial product.³⁴⁰ And the synthesis by Hogan and Banks of their crystalline polypropylene in 1953 did not make the development by Natta in 1954 of crystalline polypropylene using the Ziegler-Natta catalysts possible, nor did it make it either cheaper or faster.³⁴¹ Because Natta was not aware of Hogan and Banks' work until later, Hogan and Banks did not contribute in any way to Natta's invention. Furthermore, there is no indication that Hogan and Banks or the other chemists at Phillips understood the mechanism for the production of crystalline polypropylene through the lining up of the methyl groups on the same side of the carbon chain until after Natta's publication of his experimental results and theoretical explanation in the *Journal of the American Chemical Society* in 1955.³⁴² Moreover, Phillips claimed crystalline polypropylene only after learning of Natta's publication. The payoff that Phillips would have needed in order to recover the costs of the Hogan and Banks invention was minimal since their discovery of polypropylene was accidental in contrast to the focused activity of Ziegler and Natta in producing crystalline polypropylene.³⁴³

In spite of all these reasons for minimizing the allocation of intellectual property rights to Phillips, the Hogan and Banks patent was awarded priority over Natta's patent. Phillips was able to collect \$300 million in licensing revenues from polypropylene manufacturers through 1995³⁴⁴ even though the manufacturers did not use the Marlex catalysts described in the 1953 Hogan and Banks application, because the Ziegler-Natta catalysts produced superior quality polypropylene than that produced using the Marlex catalysts.

339. MARTIN, *supra* note 214, at 31 ("Up to this day, polypropylene is produced on an industrial scale exclusively with the use of Ziegler catalysts."); MAIER & CALAFUT, *supra* note 199, at 7.

340. Phillips Petroleum Corp. v. U.S. Steel Corp., 673 F. Supp. 1278, 1318 (D. Del. 1987).

341. See *supra* text accompanying notes 221–26.

342. See *supra* text accompanying notes 212–26.

343. See *supra* text accompanying notes 227–77.

344. Dana Rohrabacher & Paul Crilly, *The Case for a Strong Patent System*, 8 HARV. J.L. & TECH. 263, 266 (1995).

The polypropylene litigation also spawned a peculiar legal precedent for the enablement requirement that contributed to the outcome of the litigation. Under this precedent, a patentee would be permitted to claim a genus that includes unknown species that are discovered in the future if the specification describes and enables all the species that are known at the time of filing the patent application. This result is achieved through what Professors Merges and Duffy characterize as the “temporal paradox,” where the description and enablement requirements for the genus are determined as of the date of filing the patent, and the patentee gets the benefit of any additions to the genus discovered later.³⁴⁵ A line of Federal Circuit decisions from the past several years indicates this peculiar precedent has been eroded, however. The next section of the article discusses these cases.

IV. RECENT FEDERAL CIRCUIT CASE LAW

As discussed previously, the Court of Customs and Patent Appeals held in *In re Hogan*,³⁴⁶ that a patent application that disclosed and enabled a method of making the crystalline form of a polymer was entitled to a claim for the method of making a solid polymer, because the only known method for making a solid polymer at the time was the application’s method of making the crystalline form.³⁴⁷ While the Court of Custom and Patent Appeals followed *Hogan* in *In re Koller*³⁴⁸ and the Federal Circuit followed it in *U.S. Steel Corp. v. Phillips Petroleum Co.*,³⁴⁹ the Federal Circuit has limited *Hogan* in *Plant Genetic System, N.V. v. DeKalb Genetics Corp.*,³⁵⁰ and has virtually eliminated *Hogan*’s effect in *Chiron Corp. v. Genentech, Inc.*³⁵¹ One circuit panel cannot overrule a decision of an earlier panel,³⁵² but a panel in a subsequent case may interpret earlier precedent either expansively or narrowly, and the Federal Circuit appears to have drastically narrowed *Hogan*’s scope as a precedent. Since *Chiron*, the Federal Circuit has not referred to *Hogan* in any of its cases that involved claims to a genus where only a single species was enabled.³⁵³

345. See MERGES & DUFFY, *supra* note 39.

346. 559 F.2d 595, 606 (C.C.P.A. 1977).

347. See *supra* text accompanying note 289.

348. 613 F.2d 819, 823–24 (Fed. Cir. 1980).

349. 865 F.2d 1247, 1251 (Fed. Cir. 1984).

350. 315 F.3d 1335, 1341 (Fed. Cir. 2003).

351. 363 F.3d 1247, 1257 (Fed. Cir. 2004).

352. See, e.g., *LaShawn v. Barry*, 87 F.3d 1389, 1395 (D.C. Cir. 1996) (en banc) (“One three-judge panel . . . does not have the authority to overrule another three-judge panel of the court.”).

353. See *Sitrick v. Dreamworks, LLC*, 516 F.3d 993 (Fed. Cir. 2008); *Auto. Techs. Int’l, Inc. v. BMW of N. Am., Inc.*, 501 F.3d 1274 (Fed. Cir. 2007); *Liebel-Flarsheim Co. v. Medrad, Inc.*, 481 F.3d 1371 (Fed. Cir. 2007); *Lizardtech, Inc. v. Earth Res. Mapping, Inc.*, 424 F.3d 1336 (Fed. Cir. 2005).

The *Plant Genetic Systems* case was concerned with genetically engineered corn.³⁵⁴ The plaintiff had a patent for plants genetically engineered to resist a type of herbicide that killed other plants by blocking an essential biochemical process in them.³⁵⁵ The specification provided working examples of tomato, potato, and tobacco plants that were genetically engineered to resist the herbicides.³⁵⁶ Generally, flowering plants are categorized as either monocotyledons (“monocots”), dicotyledons (“dicots”), or polycotyledons (“polycots”), depending on whether they have one, two, or more than two leaves in their initial growth from seeds.³⁵⁷ All of the working examples in the specification were for plants that were dicots, but the claims were not limited to dicots and broadly covered all plants.³⁵⁸ The defendant’s accused product was corn, a monocot, which had been genetically engineered to resist the particular herbicides with which the plaintiff’s patent was concerned.³⁵⁹ The district court heard extensive testimony on the state of the art of genetic engineering at the time of filing of the patent and found clear and convincing evidence of a “monocot barrier,” which would have prevented a person of ordinary skill in the art from making genetically engineered monocots without undue experimentation.³⁶⁰ The district court accordingly ruled that the patent’s broad claims were invalid for failure to satisfy the enablement requirement because they were not limited to dicots.³⁶¹

On appeal, the Federal Circuit affirmed the district court’s decision.³⁶² The patentee argued that *Hogan* required reversal, but the Federal Circuit ruled that *Hogan* did not apply:

We do not read *Hogan* as allowing an inventor to claim what was specifically desired but difficult to obtain at the time the application was filed, unless the patent discloses how to make and use it. In *Hogan*, amorphous propylene [sic], on the record before the court, was not known or in existence when the application was filed. In the present case, however, monocots existed in 1987 and stably-transformed monocot cells were highly desirable. PGS indeed asserts that monocot cells were already being stably transformed. Thus, monocots and stably transformed monocot cells were not an unknown concept that came into existence only after 1987. But stably transformed

354. *Plant Genetic Sys., N.V. v. DeKalb Genetics Corp.*, 175 F. Supp. 2d 246, 250 (D. Conn. 2001).

355. *Id.* at 251.

356. *Id.* at 252.

357. *Id.*

358. *Id.*

359. *Plant Genetic*, 175 F. Supp. 2d at 252.

360. *Id.* at 261.

361. *Id.* at 270.

362. *Plant Genetic Sys. N.V. v. DeKalb Genetics Corp.*, 315 F.3d 1335, 1346 (Fed. Cir. 2003).

monocot cells were difficult to produce, and the '236 patent gave no instruction how.³⁶³

The court's statement in *Hogan* that "amorphous propylene . . . was not known" is inaccurate for several reasons. First, propylene is a gas at room temperature, and therefore, it surely was amorphous, rather than crystalline; of course, propylene was well known when the 1953 Hogan and Banks filed their application. Second, if the court was referring to polypropylene, rather than propylene, the court's statement is still incorrect, because *Hogan* dealt with a divisional patent application for 4-methyl-1-pentene, rather than the patent for polypropylene.³⁶⁴ Finally, the patent specification in *Hogan* characterized amorphous polymers as prior art, and therefore, they were not unknown at the time the application was filed.³⁶⁵

Because of all these factual errors, it is difficult to understand exactly what distinction the *Plant Genetic* court was trying to make between *Hogan* and the case before it. Certainly, monocots and stably transformed monocot cells were not an unknown concept in 1987, but neither was "amorphous propylene" (or whatever the *Plant Genetic* court meant to refer to) an unknown concept in 1953. If the *Plant Genetic* court intended to limit the reach of *Hogan* to species that were nonexistent and unknown even as a concept at the time of filing of a patent application, then *Hogan* would be a very narrow precedent. It would be difficult to show that a species was an unknown concept at the time a claim to the genus was filed, because it is much easier to have a concept for an invention than it is to reduce an invention to practice.³⁶⁶ Conceivably what the *Plant Genetic* court had in mind, however, was that *Hogan* permits a claim to a genus to encompass a species that was not enabled in a patent specification only if the species did not exist at the time the specification was filed. If the species did exist at the time the specification was filed, but was difficult to produce, the species would be anticipated,³⁶⁷ and therefore a claim to the species would be invalid. The *Plant Genetic* court could not have meant merely that the species did not exist, because the species would not have been patentable if it already existed. Instead the court must have meant that a person of ordinary skill in the art would have required substantially more than undue experimentation to make the species in order for a claim to a genus to encompass the species if it was not enabled in a patent specification. It is not clear how much undue experimentation should be required, however.

363. *Id.* at 1340.

364. *In re Hogan*, 559 F.2d 595, 597 (C.C.P.A. 1977).

365. *See supra* note 285.

366. For example, someone might conceive of a material with particular properties without knowing how to make it.

367. *See* 35 U.S.C. § 102(a) (2006) (invention is not patentable if it was "known or used by others in this country . . . before the invention thereof by the applicant for patent").

The last case involving the patentability of inventions in which the Federal Circuit referred to *Hogan* is *Chiron Corp. v. Genentech, Inc.*³⁶⁸ The *Chiron* case involved a patent for an antibody that bound itself to the human antigen associated with breast cancer cells; by binding to the antigen, the antibody facilitated the detection and treatment of breast cancer.³⁶⁹ The antibody was the subject of an original patent application filed in 1984 and two continuation-in-part applications filed in 1985 and 1986.³⁷⁰ The first application disclosed a type of antibody called a murine antibody, which was derived from mouse cells by cloning them.³⁷¹ Murine antibodies have the disadvantage that they are not suitable for long-term treatment of humans, because they create a risk of an immunological response that can cause toxic shock or even death on account of the antibodies having been derived from animal cells.³⁷²

Recombinant DNA technology has been used to produce other types of antibodies that include chimeric antibodies and humanized antibodies, in which part of the DNA encoding regions come from humans.³⁷³ Chimeric antibodies and humanized antibodies are more suitable for long-term treatment of humans than murine antibodies, because they have less nonhuman content.³⁷⁴ The first publication to disclose chimeric antibodies appeared four months after the filing of the first application in 1984, and the first publication to disclose humanized antibodies appeared in 1986.³⁷⁵

The two continuation-in-part applications were filed after chimeric antibody technology and humanized antibody technology, respectively, had become known in the biotechnology field. Although neither of the continuation-in-part applications disclosed chimeric or humanized antibodies, they included a broad definition of “antibody” not found in the 1984 application, which stated that it was “not intended to be limited as regards the source of the antibody or the manner in which it is made.”³⁷⁶

When the patent finally issued, Chiron sued Genentech on account of Genentech’s sales of a humanized antibody that was used in the long-term

368. 363 F.3d 1247 (Fed. Cir. 2004). The Federal Circuit cited *Hogan* in relation to the rulemaking authority of the United States Patent and Trademark Office in *Tafas v. Doll*, 559 F.3d 1349, 1360 (Fed. Cir. 2009), *reh’g en banc granted, opinion vacated by* *Tafas v. Doll*, 328 Fed. Appx. 658 (Fed. Cir. 2009).

369. *Chiron Corp.*, 363 F.3d at 1252.

370. *Id.* at 1251.

371. *Id.* at 1250.

372. *Id.* at 1251.

373. *Id.* at 1250. Antibodies have primarily two regions: a constant region and a variable region. Both chimeric antibodies and humanized antibodies may have a completely human constant region, but unlike chimeric antibodies, humanized antibodies have a variable region that is partially derived from a human. *Id.*

374. *Chiron Corp.*, 363 F.3d at 1251.

375. *Id.*

376. *Id.* at 1252.

treatment of breast cancer.³⁷⁷ The case was tried to a jury, which determined that neither the original nor continuation-in-part applications satisfied the written description and enablement requirements with respect to a claim for chimeric or humanized antibodies.³⁷⁸ The verdict form, however, did not specify which of the two requirements was not satisfied.³⁷⁹

On appeal, the Federal Circuit broke the enablement requirement into three categories based on the knowledge available at the time of the filing of a patent application. First, it found that at one end of the spectrum, a patent application preferably should not disclose routine technology that was well known to one of ordinary skill in the art.³⁸⁰ Second, citing *Hogan*, the court noted that, at the other end of the spectrum, a patent application is not required to enable technology that arises after its filing, because that would be impossible.³⁸¹ Third, the court found that an enabling disclosure is required only for nascent technology for which a person of ordinary skill in the art would need instruction from the application to practice the invention.³⁸²

The court then applied these principles to the three patent applications. It ruled that the 1984 application was outside of the bounds of the enablement requirement, because the technology for making chimeric antibodies did not arise until after the filing of the application.³⁸³ In contrast, by the time of the filing of the 1985 and 1986 continuation-in-part applications, the technology for making chimeric antibodies had become nascent technology.³⁸⁴ Consequently, the continuation-in-part applications were subject to the enablement requirement, and the court found that substantial evidence supported the jury's decision that their specifications did not enable the claims for chimeric and humanized antibodies without undue experimentation.³⁸⁵

Although the *Chiron* majority decided that the 1984 application was not subject to the enablement requirement, it nevertheless affirmed the verdict on account of the written description requirement.³⁸⁶ The court noted that the function of the written description requirement is to ensure that the inventor had possession of the subject matter of the patent when the application was filed, and that the Chiron scientists could not have had possession of chimeric antibodies because they were not developed until later.³⁸⁷ A concurring

377. *Id.*

378. *Id.*

379. *Chiron Corp.*, 363 F.3d at 1252.

380. *Id.* at 1254.

381. *Id.*

382. *Id.*

383. *Id.*

384. *Chiron Corp.*, 363 F.3d at 1255.

385. *Id.* at 1256–57.

386. *Id.* at 1255.

387. *Id.*

opinion by Judge Bryson urged that the jury verdict should have been upheld with respect to the original 1984 application as well as the 1985 and 1986 continuation-in-part applications for lack of enablement.³⁸⁸

Chiron's ruling regarding the written description requirement appears to negate the effect of *Hogan* entirely. Whenever it would be impossible for a patent application to enable an unknown species of a genus, so that *Hogan* would take the disclosure out of the enablement requirement, then it would also be impossible for the patent application to describe the unknown species. Thus, the written description requirement places the same impossible burden on a patent applicant seeking to claim a genus that includes an unknown species that an enablement requirement would have, were it not for *Hogan*. While *Hogan* provides relief from this impossible burden with respect to the enablement requirement, *Chiron* provides no such relief with respect to the written description requirement. Thus, *Chiron* renders claims that extend to unknown species invalid for failure to satisfy the written description requirement rather than the enablement requirement. Whether a patent is invalid for failure to satisfy one requirement or the other, the end result is the same.

The Federal Circuit next addressed the issue of the validity of a claim to a genus based on the disclosure of a species within the genus in *Lizardtech, Inc. v. Earth Resource Mapping, Inc.*³⁸⁹ *Lizardtech* had a patent for data compression software for digital images that included a claim for a method of creating a seamless digital wave transform (“DWT”) of the image data and then processing the data to permit storage of the transformed image in a computer with a limited memory.³⁹⁰ The specification disclosed one way to create the seamless DWT, which was by “maintaining updated sums” of DWT coefficients calculated from the image data.³⁹¹ But the claim in issue did not specify how the seamless DWT was created, and therefore, it purported to cover all ways of creating the seamless DWT.³⁹²

The Federal Circuit decided that there was no support for such a broad claim in the specification, because it failed to demonstrate that the inventor possessed the full scope of the claim and failed to enable the full breadth of the claim. It explained:

388. *Id.* at 1261–63 (Bryson, J., concurring).

389. 424 F.3d 1336 (Fed. Cir. 2005).

390. *Id.* at 1337. For a thorough and insightful description of the factual background of the case, see *Merges*, *supra* note 153.

391. *Lizardtech*, 424 F.3d at 1340.

392. *Id.* at 1340–41. Another of the claims included the “maintaining updated sums” limitation, but the court had ruled that the defendant had not infringed that claim because the defendant used an alternative method for creating the seamless DWT. *Id.* *Lizardtech* then argued that the defendant infringed the broader claim. *See id.* at 1343.

By analogy, suppose that an inventor created a particular fuel-efficient automobile engine and described the engine in such detail in the specification that a person of ordinary skill in the art would be able to build the engine. Although the specification would meet the requirements of section 112 with respect to a claim directed to that particular engine, it would not necessarily support a broad claim to every possible type of fuel-efficient engine, no matter how different in structure or operation from the inventor's engine. The single embodiment would support such a generic claim only if the specification would "reasonably convey to a person skilled in the art that [the inventor] had possession of the claimed subject matter at the time of filing," and would "enable one of ordinary skill to practice 'the full scope of the claimed invention,'" To hold otherwise would violate the Supreme Court's directive that "[i]t seems to us that nothing can be more just and fair, both to the patentee and the public, than that the former should understand, and correctly describe, just what he has invented, and for what he claims a patent." Thus, a patentee cannot always satisfy the requirements of section 112, in supporting expansive claim language, merely by clearly describing one embodiment of the thing claimed. For that reason, we hold that the description of one method for creating a seamless DWT does not entitle the inventor of the '835 patent to claim any and all means for achieving that objective.³⁹³

It is significant that the court did not address whether alternatives to creating a seamless DWT were known at the time of filing the patent application, because in the *Plant Genetics* case the Federal Circuit relied on the knowledge of the other members (i.e., genetically engineered monocots) of the claimed genus (i.e., genetically engineered plants) to distinguish it from *Hogan*.³⁹⁴ The *Lizardtech* decision did not refer to either the *Hogan* or *Plant Genetic* cases.

*Liebel-Flarsheim Co. v. Medrad, Inc.*³⁹⁵ is another case in which the Federal Circuit held claims invalid for lack of enablement due to lack of support in the specification. The patent was for power fluid injectors used to inject fluids into patients during medical procedures.³⁹⁶ Although all the examples in the specification included a pressure jacket on the injectors, the claims did not require the injectors to have a pressure jacket.³⁹⁷ The district court determined that the claims were invalid for lack of enablement of

393. *Id.* at 1346 (citations omitted).

394. *See supra* text accompanying note 363.

395. 481 F.3d 1371, 1378–79 (Fed. Cir. 2007).

396. *Id.* at 1373.

397. *Id.* at 1374. When the original patent application was filed, the claims included the limitation of a pressure jacket on the injectors, but the patentee removed this limitation from the claims during patent prosecution after learning that the defendant was making a jacketless injector system. *Id.*

injectors without a pressure jacket, and the Federal Circuit affirmed.³⁹⁸ The appellate court explained:

[I]n this case, the asserted claims read on, and the full scope of the claimed invention includes, an injector system with and without a pressure jacket. There must be “reasonable enablement of the scope of the range” which, in this case, includes both injector systems with and without a pressure jacket.³⁹⁹

The Federal Circuit also found claims invalid for lack of enablement because they extended beyond the specification in *Automotive Technologies International, Inc. v. BMW of North America, Inc.*⁴⁰⁰ The case involved crash sensors for use in deploying airbags during side impact car accidents which were triggered by a vehicle’s velocity changes upon exceeding a threshold value.⁴⁰¹ The claims did not specify the particular types of sensors to be used in the invention, but the specification had a detailed description of a mechanical velocity sensor and a briefer description of an electronic sensor.⁴⁰² The district court decided that the claims were invalid with respect to electronic sensors, because the description of them in the specification was not sufficiently detailed to enable a person of ordinary skill in the art to make them.⁴⁰³

The Federal Circuit affirmed and explained:

We also reject ATI’s argument that because the specification enables one mode of practicing the invention, *viz.*, mechanical side impact sensors, the enablement requirement is satisfied. We addressed and rejected a similar argument made in *Liebel-Flarsheim Co. v. Medrad, Inc.*, 481 F.3d 1371 (Fed. Cir. 2007)

Similarly, in this case, the claim construction of the relevant claim limitation resulted in the scope of the claims including both mechanical and electronic side impact sensors. Disclosure of only mechanical side impact sensors does not permit one skilled in the art to make and use the invention as broadly as it was claimed, which includes electronic side impact sensors. Electronic side impact sensors are not just another known species of a genus consisting of sensors, but are a distinctly different sensor compared with the well-enabled mechanical side impact sensor that is fully discussed in the specification. Thus, in order to fulfill the enablement requirement, the specification must enable the full scope of the claims that includes both

398. *Id.* at 1375, 1378.

399. *Liebel-Flarsheim*, 481 F.3d at 1380. The court also pointed out that it was ironic that the plaintiff had successfully argued that the claims encompassed injectors with no pressure jackets, but lost the case in the end because the broad claims were invalid for lack of enablement. *Id.*

400. 501 F.3d 1274, 1285 (Fed. Cir. 2007).

401. *Id.* at 1276–77.

402. *Id.*

403. *Id.* at 1280.

electronic and mechanical side impact sensors, which the specification fails to do.⁴⁰⁴

The Federal Circuit's most recent case on the enablement of a claim to a genus is *Sitrick v. Dreamworks, LLC*.⁴⁰⁵ Sitrick had two patents for integrating a user's audio signal or visual image into a pre-existing video game or movie.⁴⁰⁶ Sitrick sued Dreamworks for infringement of these patents on account of Dreamworks's including in the DVDs it made and distributed a feature called ReVoice Studio that allowed users to add their own voices to the movies on the DVDs.⁴⁰⁷ Sitrick's patents included claims for the integration or substitution of a visual or audio user image in place of a predefined image in a presentation.⁴⁰⁸ The specifications "described the 'integration' or 'substitution' as being performed by an 'Intercept Adapter Interface System' (IAIS)," which is used "[i]n a video game system . . . to intercept address signals . . . [between] the video game apparatus and . . . the game card or storage card."⁴⁰⁹ The claims were not restricted to video games, however, and the specification of one of the patents began: "[T]his invention relates to predefined video and audiovisual presentations such as movies and video games."⁴¹⁰

The district court found all the claims invalid for lack of enablement as to movies, because the patent specifications did not explain how the IAIS from a video game system would work for movies. It noted that Dreamworks' experts had testified that video games differed significantly from movies, because in video games, the images of the various characters in the story were retrieved by discrete address signals, while the images of the characters in pre-existing movies were inseparable from the surrounding images. Consequently, the techniques for intercepting address signals for video games had no relevance to movies, and the disclosure did not enable use of the IAIS for movies.⁴¹¹ In affirming the district court, the Federal Circuit held:

The full scope of the claimed invention must be enabled. The rationale for this statutory requirement is straightforward. Enabling the full scope of each claim is "part of the *quid pro quo* of the patent bargain." A patentee who chooses broad claim language must make sure the broad claims are fully enabled. "The scope of the claims must be less than or equal to the scope of the enablement" to "ensure[] that the public knowledge is enriched by the patent

404. *Id.* at 1285 (citations omitted).

405. 516 F.3d 993 (Fed. Cir. 2008).

406. *Id.* at 995–96.

407. *Id.*

408. *Id.* at 997.

409. *Id.*

410. *Sitrick*, 516 F.3d at 996.

411. *Id.* at 998, 1000.

specification to a degree at least commensurate with the scope of the claims.”⁴¹²

The *Lizardtech*, *Liebel-Flarsheim*, *Automotive Technologies*, and *Sitrick* cases each dealt with a claim to a genus based on a specification that enabled only one species in the genus. In each case, the Federal Circuit emphasized that a claim to a genus would not satisfy the enablement requirement if the specification enabled only a single species; instead, the specification was required to enable the full scope of the claim. None of these cases referred to *Hogan* or addressed whether the enablement requirement was not applicable on account of a species within the genus that was not known or in existence at the time of filing and therefore was impossible to enable then. In light of the limitation on *Hogan* in *Plant Genetic* that a species must have been an “unknown concept that came into existence only after” the filing of the patent specification to avoid the enablement requirement, and the holding in the *Chiron* case that a claim to a genus would not satisfy the written description requirement with respect to an unknown species, it appears that there is little left of *Hogan* as a precedent.⁴¹³

CONCLUSION

The allocation of intellectual property rights between earlier and later inventors of related technology involves inevitable tradeoffs. To the extent that an earlier inventor receives a blocking patent with respect to after-arising technology that a later inventor makes, the later inventor may lack the appropriate incentive to create the after-arising technology. But if the earlier inventor is not allowed a blocking patent with respect to the after-arising technology, the earlier inventor may lack the appropriate incentive to create the original invention on which the after-arising technology depends.

It would seem that the optimal allocation of the intellectual property rights in after-arising technology between the earlier and later inventors should depend on their relative contributions and the effect that the allocation of intellectual property rights would have on their respective incentives. Instead of basing the allocation on these types of particularized considerations, however, the patent law uses broad, across-the-board rules. The first is that a patent on an original invention (A) will dominate a patent on an improvement that involves a combination of the original invention with an additional component (A+B). Although the later inventor may receive a patent for the improvement, that patent is blocked by the patent on the original invention, and the earlier inventor’s permission is required for the later inventor to

412. *Id.* at 999 (internal citations omitted).

413. *Plant Genetic Sys. N.V. v. DeKalb Genetics Corp.*, 315 F.3d 1335, 1340 (Fed. Cir. 2003).

practice the patent on the improvement. The second is that a patent on a product will dominate a later patent on a process for making or using the product.

Beyond these instances of blocking patents, several cases beginning with *In re Hogan* ruled that an earlier inventor of a single species was entitled to a broad claim to a genus if that species was the only member of the genus in existence at the time of the patent application, and then the patent would dominate later patents for other species within the genus that were developed later.

The doctrinal basis for *Hogan* was that the enablement requirement for patentability is tested at the time of filing the patent application, and that the scope of a patent could extend to after-arising technology that was within the broad claim to the genus that included a species which the patent's disclosure enabled. The holding in *Hogan* appears to have been eroded by recent Federal Circuit decisions, though. First, the Federal Circuit limited *Hogan* in *Plant Genetic System, N.V. v. DeKalb Genetics Corp.* to circumstances where the after-arising technology was not merely difficult to produce, but was instead an unknown concept.⁴¹⁴ Then, in *Chiron Corp. v. Genentech, Inc.*, the Federal Circuit held that even if a claim to a genus could satisfy the enablement requirement with respect to the after-arising technology, the claim would nevertheless be invalid because it could not satisfy the written description requirement.⁴¹⁵ Since *Chiron* was decided, *Hogan* has not been cited in any of the four cases where the Federal Circuit has ruled that patents with broad claims did not satisfy the enablement and written description requirements because their patent specifications did not support the full range of the claims.

The loss of *Hogan* as a precedent seems warranted from an economic standpoint. It is certainly possible that the invention of the first species in a genus would contribute to the development of other species in the genus. It is likely, however, that this would not be so much of the time, and unless the invention of the first species contributed to the development of other species, intellectual property rights to the other species should not be allocated to the inventor of the first species in the genus. Consequently, blocking patents should be limited to inventions involving combinations of an earlier invention with an additional component and processes for making or using a patented product.

414. 315 F.3d 1335, 1340 (Fed. Cir. 2003).

415. 363 F.3d 1247, 1253 (Fed. Cir. 2004).