

DEVELOPMENT OF AN IMPROVED PRESSURE VARYING HYDRAULICALLY OPERATED AGRICULTURAL WASTE BRIQUETTING MACHINE

Oke Peter Kayode and Olaiya Niyi Gideon

Department of Industrial and Production Engineering, Federal University of Technology,
Akure, Ondo State, Nigeria.

Department of Industrial and Production Engineering, Federal University of Technology,
Akure, Ondo State, Nigeria.

Email: pkoke@futa.edu.ng; ngolaiya@futa.edu.ng

Abstract: *In several developing countries, briquettes from agricultural residues contribute significantly to the energy mix especially for small scale and household requirements. Most times, these briquettes are produced from manually operated briquetting machine where the pressure at which the agricultural waste is compressed cannot be ascertained. Therefore, this work deals with the design and fabrication of pressure varying hydraulically operated briquetting machine. This machine can produce sixteen (16) briquettes at a time. The machine was developed in order to reduce stress of producing the briquette and to establish the optimum pressure at which the agricultural waste is compressed. The varying pressure at which the briquette is compressed was used to establish the effect of pressure on the calorific value of the briquette. The agricultural waste that were used for the briquette include palm kernel shell, rice bran, and saw dust with cassava starch as the binder. Each agricultural waste particle was loaded in the machine mould at different times at varying pressures of 30, 70, and 100 kg/cm². The result shows that the briquette of sawdust has the highest heating value of 17.585 at 70 kg/cm² pressure while the highest value was recorded for rice bran as 13.722 at 100 kg/cm² and 18.342 MJ/kg at 100 kg/cm² pressure for palm kernel shell.*

Keywords: *Hydraulic, Varying Pressure, Briquetting machine, Calorific Value*

1. INTRODUCTION

Briquetting involves the densification process of loose organic materials, such as rice husk, sawdust and coffee husk aiming at improving handling and combustion characteristics. There are two principal methods of briquetting, with or without a binder. The binder technology is used where low-pressure presses are employed to produce briquette. Binders are added to this process to improve mechanical strength and allow dry materials to be briquetted using low pressure techniques as simple block presses or extrusion presses. During this process, fine material is compacted into regular shape and size which does not separate during transportation, storage or combustion. In some briquetting techniques, the materials are simply compressed without addition of adhesive (binder less briquettes) (Mangena and Cann, 2007) while in some, adhesive material is added to assist in holding the particles of the material together. The binder less technology is a high-pressure technique which produces briquettes from fine dry particle size materials without a binder being added. Three types of press are commonly used. Piston press, pelletizers and screw extrusion presses.

Briquettes are burned the same way as wood and can be used directly in open fires, gasifiers, boilers, furnaces and kilns. Traditionally, wood in form of fuel wood, twigs and charcoal has been the major source of renewable in Nigeria, accounting for about 51% of the total annual energy consumption; the other sources of energy include natural gas (5.2%), hydroelectricity (3.1%), and petroleum products (41.3%) (Akinbami, 2001).

Biomass, particularly agricultural residues seem to be one of the most promising energy resources for developing countries (Patomsok, 2008). Rural households and minority of urban dwellers depend solely on fuel woods (charcoal, firewood and sawdust) as their primary sources of energy for the past decades (Onuegbu, 2010). Out of all the available energy resources in Nigeria, coal and coal derivatives such as smokeless coal briquettes, bio-coal briquettes, and biomass briquettes have been shown to have the highest potential for use as suitable alternative to coal/ fuel wood in industrial boiler and brick kiln for thermal application and domestic purposes.

Over the years different development has been made on briquetting machines, for instance the Tube-Presser consist of a tube mounted vertically on a platform and a close-fitting ram used for compaction. Metal or plastic pipe provides a good briquetting mould since it produces cylindrical briquettes (Davies 1985). The screw presser makes briquettes in upright cylinders. The raw material is compressed by lowering a metal disc which is moved vertically by a screw that is turned by hand. The screw press is most commonly made of metal. (Olle and Olof 2006). The heat die extrusion screw press is an industrial machine for producing briquettes. It consists basically of an electric motor, a hopper, a die heater and muff, and the screw which densifies the raw material. These machine works best with dry (15% moisture content maximum) cellulose material, which is fed into a compression chamber. A reciprocating piston then forces the material through a tapered die to form a long briquette. (Bhattacharya et al, 1984). More recent are the Pelletizer Pellet presser and The Wu-presser (developed by the Washington University). It is constructed from either metal or wooden parts (Legacy Foundation 2003). The hydraulically operated briquette machine in this study operates by hydraulic pressure acting upon a piston that extrudes the material through a longitudinal die.

1.1 Purpose of the study

This study is the development and performance evaluation of a hydraulic machine for production of briquette at different pressure

2. LITERATURE REVIEW

Over the years different development has been made on briquetting machines, for instance the Tube-Presser consist of a tube mounted vertically on a platform and a close-fitting ram used for compaction. Metal or plastic pipe provides a good briquetting mould since it produces cylindrical briquettes (Davies 1985). The screw presser makes briquettes in upright cylinders. The raw material is compressed by lowering a metal disc which is moved vertically by a screw that is turned by hand. The screw press is most commonly made of metal. (Olle and Olof 2006). The heat die extrusion screw press is an industrial machine for producing briquettes. It consists basically of an electric motor, a hopper, a die heater and muff, and the screw which densifies the raw material. These machine works best with dry (15% moisture content maximum) cellulose material, which is fed into a compression chamber. A reciprocating piston then forces the material through a tapered die to form a long briquette. (Bhattacharya et al, 1984). More recent are the Pelletizer Pellet presser and The Wu-presser (developed by the Washington University). It is constructed from either metal or wooden parts (Legacy Foundation 2003).

Several other authors (Gürkan et al., 2017; Osarenmwinda et al., 2012; Mambo et al., 2016; Kishan, et al.,2016; Ojaomo et al., 2015 and Oumarou, et al., 2010), the limitation either its manually operated, number of mould or non -pressure varying which is a major factor in briquette moulding. Recently Gbabo et al., 2017 and Manjunath et al., 2018 developed a hydraulically operated machine for making briquette from agricultural. The equipment can convert agricultural waste materials like rice husk, saw dust and sugar cane

bagasse to briquettes that can produce heat energy useful for domestic and industrial applications the limitation is it can mould twelve (12) briquette and the pressure can't be varied. The hydraulically operated briquette machine in this study operates by hydraulic pressure acting upon a piston that extrudes the material through a longitudinal

3. METHODOLOGY

The important properties considered are strength, ductility, toughness, rigidity and compression. Mild steel was used for the Mould Box (Compression Chamber) and the body frame. The machine sections are Briquette compression chamber, Metal cover plate of 10mm thickness, Automatic press (Figure 1 to 3)

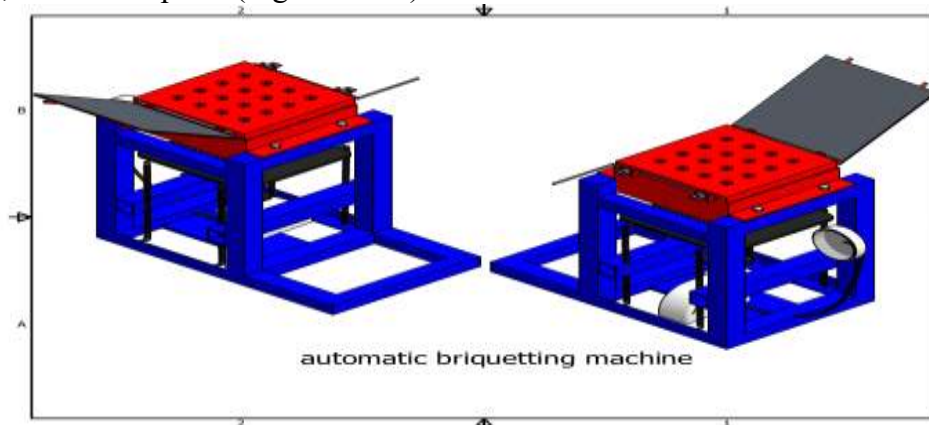

Figure 1: Isometric drawing of automatic briquetting machine

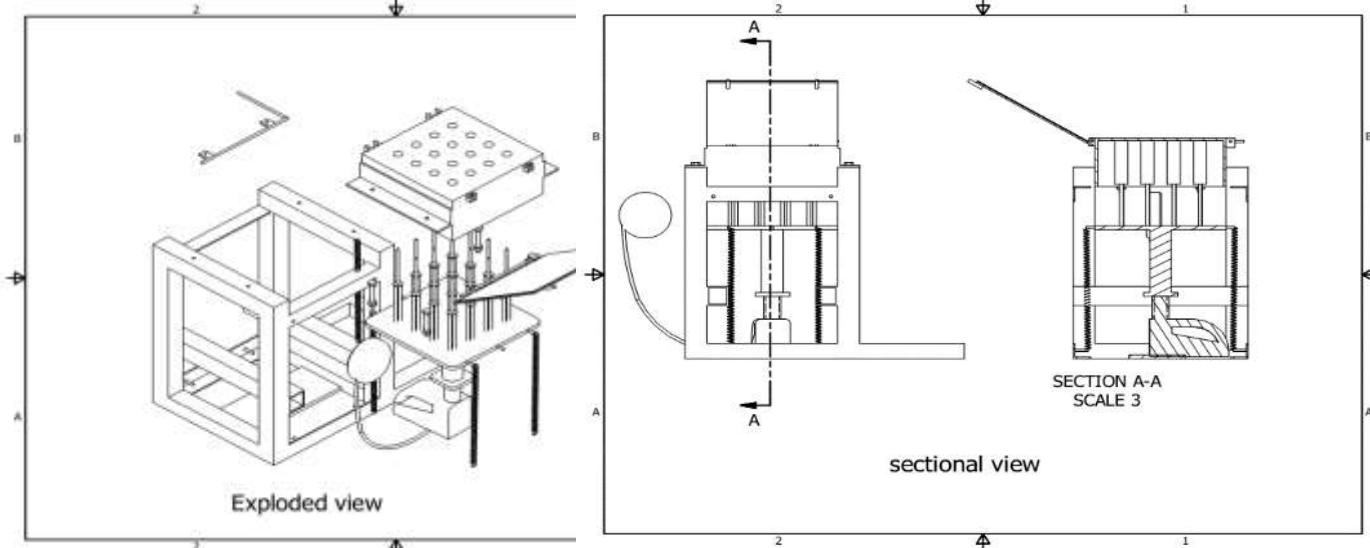

Figure 2. Exploded and Section view of the machine

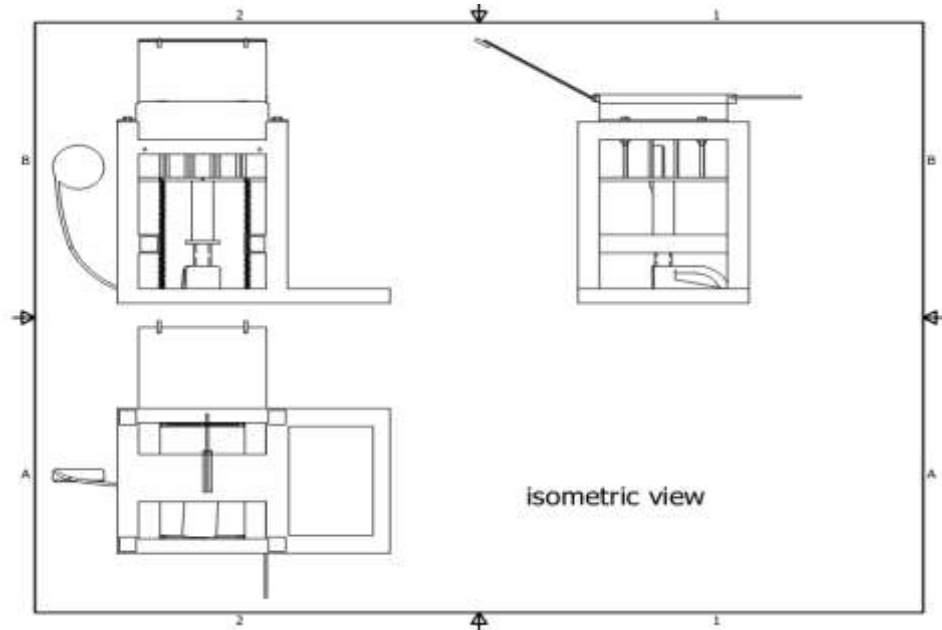

Figure 3. Orthographic View

3.1 Design for briquette compression chamber

The compression chamber has $L \times B \times H = 305\text{mm} \times 305\text{mm} \times 140\text{mm}$, with 16 cylindrical compaction chamber steel pipes with 40mm diameter. The automatic briquetting machine was designed to produce sixteen briquettes (16) at a time.

Total area which pressure acts (total compacted area)

$A_c = \text{number of mould dies} \times \text{cross sectional area of die}$

$$= n \times \frac{\pi}{4} \times D^2 \quad (1)$$

Where $D = \text{Diameter of moulding}$

$$= 0.04\text{m}$$

$$n = \text{number of mould die} = 16$$

$$\pi = 3.142$$

$$A_c = 0.0201\text{m}^2$$

$$\text{Mass of ejection rod } m_e = 0.45\text{kg}$$

$$\text{Total mass of ejection rod } Tm_e = 2n \times m_t (\text{kg}) \quad (2)$$

$$= 14.4\text{kg.}$$

Mass of each ejection piston m_p

$$= 0.1\text{kg}$$

$$\text{Total mass of ejection piston } Tm_p = n \times m_p (\text{kg}) = 1.6\text{kg} \quad (3)$$

Mass of base plate $m_b = 4.5\text{kg}$

Mass of one wet briquette sample m_w

$$= 0.05\text{kg}$$

Total mass of wet briquette sample $= Tm_w = n \times m_w$

$$= 0.8\text{kg}$$

Mass of transmission rod $m_t = 1.4\text{kg}$

$$\text{Total mass to be lifted by hydraulic jack } Tm_h = Tm_e \times Tm_p \times m_b \times Tm_w \times m_t \quad (4)$$

$$= 22.7\text{kg}$$

Take acceleration due to gravity $(g) = 10\text{m/s}^2$

Total weight to be lifted by the automatic hydraulic jack $Tw_l = \text{total mass to be lifted by automatic jack} \times \text{acceleration due to gravity.}$

$$Tw_l = Tm_h \times g \quad (5)$$

$$= 227N$$

The briquetting machine was outsourced. The compaction force was calculated using the pressure reading from the pressure gauge connected to the hydraulic jack.

3.2 Design for metal cover plate

The cover plate has a dimension of 305mm × 305mm × 10mm, it is attached to the compression chamber using hinges.

$$\begin{aligned} \text{Volume} &= L \times B \times H \\ &= 930250mm^3 \end{aligned} \tag{6}$$

3.3 Design for body frame

The body frame used for this design is a U-channel frame with dimensions 381mm × 483mm × 762mm with a support base.

3.4 Design for automatic press component

The automatic press is made up of the following components

1. Automatic hydraulic jack
2. The push rods
3. Return spring
4. Base plate

3.5 Hydraulic jack specification

Capacity = 1 tonne

Voltage = D.C 12 V

Maximum height = 360mm

Minimum height = 135mm

Operating circuit = 15A

Weight = 4.85kg

3.6 Pistons specification

$$\begin{aligned} \text{Diameter of piston} &= \frac{\pi d^2}{4} \\ &= \frac{\pi \times 39^2}{4} \\ &= 1194.6mm^2 \end{aligned} \tag{7}$$

Allowable stress for the spring = 586(MN/m²)

Axial force on spring = 490.5N

3.7 Total stress in the spring

Helical springs are made of circular cross section wire rod. They are subjected to torsional shear stress and a transverse shear stress. The shear stress induced in the helical spring due to an axial load F is given by:

$$S_s = \frac{K8FD_{in}}{\pi d^3} = \frac{K8F}{\pi d^2} \tag{8}$$

S_s = Shear stress

F = Axial load(N)

D_{in} = Mean diameter of coil (m)

d = diameter of wire (m)

K = wahl factor

C = spring index

4. RESULTS AND DISCUSSION

The mechanical system contains individual mechanical parts of the machine's framework such as the mixing chamber, cylinder mould, die and ram. The control system of the machine is composed of mainly the electrical system which composed of the battery, switches, electrical wires and the pressure gauge system. The main frame houses and support the other

parts of the machine. It is to be made from mild steel iron bar. The compaction chamber was made from mild steel, the base plate was made from mild steel and it's to be housed within the frame of the machine, just beneath the compaction chamber. Thirty-two (32) transmission mild steel rods are welded to the base plate of the machine, and this rod goes into the hole made at the base of the machine to support the ejection piston.

The palm kernel shell used was gotten from the local market, after which it was taken to the grinder to get it into smaller particle sizes. The palm kernel shell particle was then mixed with starch. Other two agricultural waste which include; rice bran and saw dust were also mixed with cassava starch as binder and all the samples were poured into the briquetting machine in which different briquette was made and dried. The machine was used to make sixteen (16) briquette at a time (see plate 2) and it worked perfectly without any fatigue. Each agricultural waste particles were loaded into different moulds on the machine and it was compacted at different varying pressure of 30, 70 and 100 kg/cm². The result shows that the briquette of sawdust has the highest heating value of 17.585 at 70kg/cm² pressure while the highest value was recorded for rice bran as 13.722 at 100kg/cm² and 18.342 MJ/kg at 100kg/cm² pressure for palm kernel shell as shown in figure 1.



Plate 1: Plan and front view of the hydraulically operated agricultural waste briquetting machine



Plate 2: Sixteen (16) briquettes mould

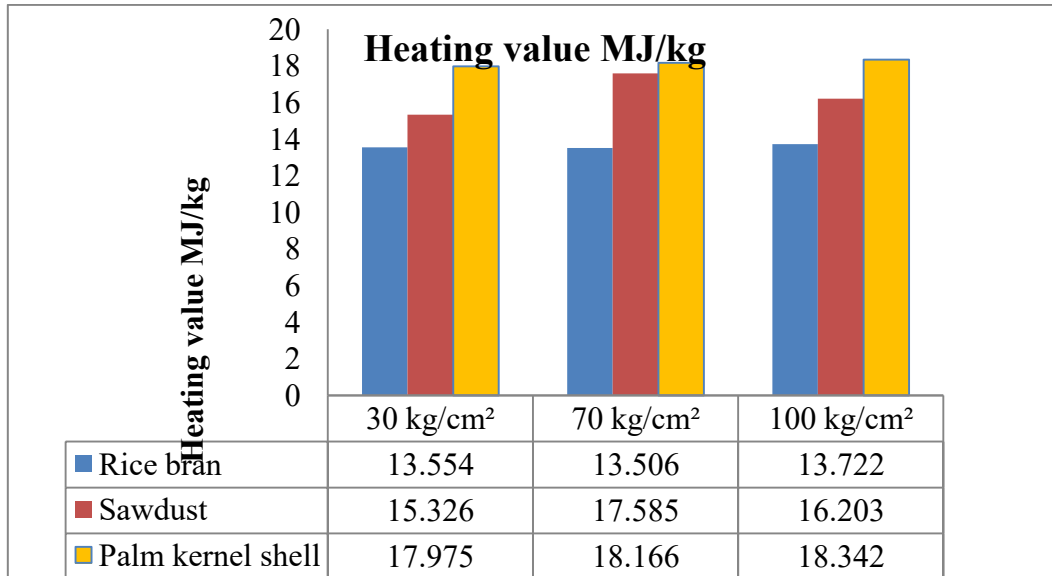

Figure 4. Heating Value of Rice bran, Sawdust and Palm Kernel Shell briquette

5. CONCLUSION

This result established that pressure variation affect the calorific value of the agricultural waste briquette. This fact is to be taken into consideration in briquette making process. This machine has the maximum pressure (figure 4) variation of 100Kg/cm²

REFERENCES

- Gbabo A., Onatola T. and Gana D I. M. (2017). Design and fabrication of hydraulically operated machine for making briquette from agricultural waste. International Standard Journal Number (ISJN) e-ISJN: A4372-2604. 5 (3), 121-129.
- Gürkan Alp Kağan GÜRDİL, Bahadır DEMİREL (2017). Design and Construction of a Hydraulic Briquetting Machine for Hazelnut Husk Agricultural Residue. 58th ICMD.6 - 8 September 2017, Prague, Czech Republic
- Osarenmwinda, J O and Ihenyen O.I. (2012). The Preliminary Design and Fabrication of a Manually Operated Briquetting Machine. J. Appl. Sci. Environ. Manage. 16 (2) 209 – 211.
- Mambo W., Kamugasha D., Adimo O., Okwalinga D. B., Namagembe F. (2016). Development and Performance Evaluation of a Manually Operated Hydraulic Briquetting Machine International Journal of Scientific and Engineering Research, 7(11),1083 - 1087. ISSN 2229-5518. <http://www.ijser.org>.
- Kishan B. S., Kiran K., Santhosh T. J., and Gangadhar A. D. (2016). Design and Fabrication of low-cost Briquetting machine and Estimation of Calorific values of Biomass Briquettes. International Journal of Innovative Research in Science, Engineering and Technology.5 (7), Copyright to IJIRSET DOI:10.15680/IJIRSET.2016.0507055 12454
- Ojaomo, E. K., Maliki, O. B. and Olusanya, A. J. (2015). Development of a Simple Briquetting Machine for Small Scale Application. International Journal of Engineering Research and Technology (IJERT). 4(5), ISSN: 2278-0181
- Manjunath K. S., Omprakash M., Niranjan P., and Biradar H. (2018). Design and Fabrication of Briquetting Machine for Solid Waste. International Journal of Latest Engineering Research and Applications (IJLERA) ISSN: 2455-7137. 3(5), 61-66 www.ijlera.com.

- Oumarou M. B. And Oluwole F.A. (2010). Design of a Pedal Operated Briquette Press. Continental J. Engineering Sciences 5:61 - 67, 2010 ISSN: 2141 - 4068©Wilolud Journals
- Davis, M. C. (1985). Understanding briquetting. Technical paper, No. 31. Published by Volunteers in Technical Assistance (VITA). ISBN: 0-86619-233-6 Virginia USA.
- FAO. (1992). Food and Agriculture Organization year book
- Government of Nigeria (1997). Introduction provided by the government of Nigeria to the United Nations Commission on Sustainable Development, 5th section 7 – 25 April 1997. New York. United Nations Department of Policy Coordination and Sustainable Development.
- Legacy Foundation. (2003). Fuel Briquette press kit. A construction manual.
- Akinbami, J.F.K. (2001). Renewable Energy Resources and Technologies in Nigeria: Present Situation, Future Prospects and Policy Framework. Migration and Adaptation Strategies for Global Changes 6: pp. 155 – 181.
- Mangena, S. J. and Cann, V. (2007). Binderless Briquetting of Some Selected South Africa Prime Cooking. International Journal of Health Maintenance: 71(45): pp 300- 312.
- Olle, F. and Olof, N. (2006). Biomass Briquettes in Malawi, Degree Project, Department of Management and Engineering, Institute of Technology, Linkoping University, Malawi
- Onuegbu, T. U. 2010. Improving Fuel Wood Efficiency in Rural Nigeria, (A Case of Briquette Technology). International Journal of Chemistry in Nigeria: 3(4): pp 35-39.
- Patomsok, W. 2008. Density Equation of Bio-coal Briquette and Quantity of Maize Cob. Thailand: Sample Express Inc.