



Correlation between Locus of Control and Personal Responsibility through Pro-Environmental Intention in High School Students

Ahsanul Akhsan Dasi, Mieke Miarsyah, Rusdi

Biology Education, Universitas Negeri Jakarta, Indonesia

e-mail: ahsanulakhsandasi@gmail.com

Received: December 20th, 2018

Revised: January 8th, 2019

Accepted: September 5th, 2019

ABSTRACT

This study aims to know the relationship between locus of control (X_1), and personal responsibility (X_2) with pro-environmental intention in XI MIPA students at SMAN 8 Makassar, South Sulawesi (Y). Partisipants for study were 120 students. Based on data analysis can be known coefficient correlation between X_1 with Y , coefficient correlation between X_2 with Y and coefficient correlation between X_1 and X_2 with Y . Locus of control and personal responsibility has contributed to the pro-environmental intention of 12.7%.

Keywords: Environmental, locus of control, personal responsibility, pro-environmental intention

INTRODUCTION

Changes in ecosystems are caused by human activities, climate change, habitat changes (changes in land use and physical adjustment of natural resources), changes in population, over-exploitation, technological change, and pollution (Keshavarz & Karami, 2016). Various environmental problems pose a threat to the environment, including global warming, urban air pollution, lack of water, environmental noise, and loss of biodiversity. Many of these problems are rooted in human behavior and thus can be managed by changing relevant behaviors so as to reduce their environmental impact (Steg & Vlek, 2009).

Problem-solving for the environment can be done by the community component as well as personally. One effort that can be done to solve environmental problems is in the form of fostering a desire to care about the environment that affects a person's behavior. Hines, Hungerford, and Tomera developed a model of environmentally responsible behavior. In their model, one of

the desires to care about the environment is influenced by personality factors. personality factors are the locus of control and personal responsibility (Pan, Chou, Morrison, & Lin, 2018).

Locus of control is a stable behavior that is in a person and has a belief about success and failure that is influenced by his own behavior or external factors (Rucas & Miller, 2013). Locus of control has a tendency that an individual believes the results of his efforts come from his behavior or are controlled by external forces such as fate, luck, opportunity or something else. Those who have an internal locus of control feel the results of events that depend on their own actions, while those who have an external locus of control feel the results of events that depend on external factors (Erkan, 2015).

Locus of control can also be said as a person's belief in the causes of success and failure experienced. In its relation to the desire to act on the environment, the locus of control is an important predictor of the desire to act and has a substantial direct effect on attitude, which in turn affects the desire to

act on students towards the environment. Based on research by Yang, Lin, & Liu (2016) states that locus of control relates to the desire to act on students towards the environment. Based on this information, the locus of control is one of the personality factors that determine the desire to act on the environment of students.

Personal responsibility is most commonly understood as accepting responsibility for its own actions, or lack of actions and consequences produced (Mergler, 2007). Personal responsibility is the ability to regulate one's own thoughts, feelings, and behaviors, along with a willingness to be responsible for choices made based on the social and personal results produced (Mergler, Spencer, & Patton, 2008). Personal responsibility is defined as the belief that someone is the ruler of his life, aware of his choices and goals and is willing to demand accountability for his behavior and get the consequences (Mergler & Shield, 2016).

The model that describes the relationship between locus of control and personal responsibility with the intention to act can be seen in Figure 1 (Hines, Hungerford, & Tomera, 2010).

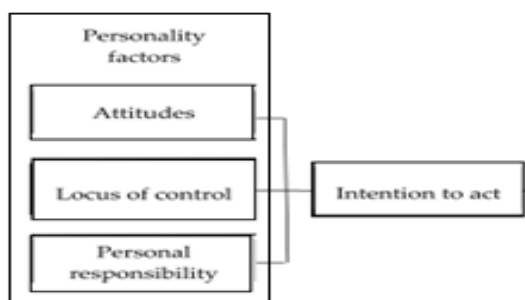

Figure 1. Environmental Behavior Model (Hines et al., 2010)

Based on a previous exposure, the locus of control and personal responsibility are personality factors that influence students' intention to act on the environment. Therefore, research is needed on the relationship between locus of control and personal responsibility with the intention to

act on the environment or can be referred to as the pro-environmental intention.

METHOD

This research used quantitative approach with correlational descriptive research type. Participants for the study were 120 students (valid responses). Sample was based on multistage random sampling technique. Determination of the sample size using McClave formula. Data collection used non-test instruments.

This study analyzed the correlation between locus of control (X1) with pro-environmental intention (Y), correlation between personal responsibility (X2) with pro-environmental intention (Y). Correlation between locus of control (X1), and personal responsibility (X2) with pro-environmental intention (Y). The design of this study is as Figure 2.

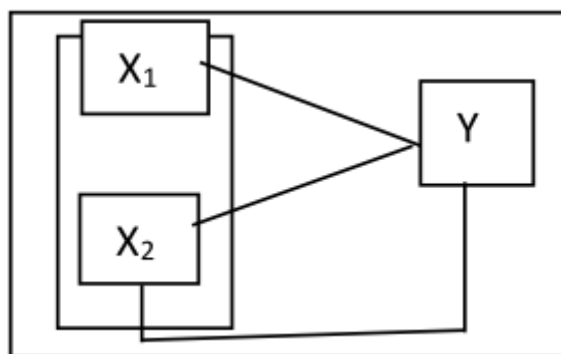

Figure 2. Research Design

RESULT AND DISCUSSION

Results

Analysis of data in this study begins with the test requirements correlation analysis. The analytical requirements used consisted of normality test, homogeneity test, linearity test and regression analysis used Kolmogorov-Smirnov Test. The analysis used SPSS.

Data Descriptions

Data for the description of each of the follow variables showed the average, median, standard deviation, sample

variation, range, maximum score and minimum score.

Table 1. Descriptive Analysis

Statistics			
	X ₁	X ₂	Y
Mean	59,33	82,68	77,1
Std. Deviation	12,16	10,72	10,83
Variance	147,87	114,92	117,38
Range	65	54	42
Minimum	20	45	51
Maximum	85	99	93
Sum	7120	9922	9252
N	120	120	120

X₁ = locus of control
 X₂ = personal responsibility
 Y = pro-environmental intention

Normality Test

Normality test used Kolmogorov-Smirnov Test. Details of normality test results on each variable can be seen in Table 2.

Table 2. Normality Test Results

No	Var.	P _{Provision}	P _{result}
1	X ₁	0,05	0,052
2	X ₂	0,05	0,053
3	Y	0,05	0,064

X₁ = locus of control
 X₂ = personal responsibility
 Y = pro-environmental intention

The results obtained are the significance value (p) locus of control is 0.052, the significance value (p) for personal responsibility is 0.053 and the significance value (p) for the pro-environmental intention is 0.064. This showed that the three groups of data are normally distributed.

Homogeneity Test

Table 3. Homogeneity Test Results

No	Var.	Sig.
1	X ₁ with Y	0,901
2	X ₂ with Y	0,172
3	X ₁ and X ₂ with Y	0,305

X₁ = locus of control
 X₂ = personal responsibility
 Y = pro-environmental intention

Based on Table 3. The homogeneity test results in all three groups of data indicated sig score. Significance value (p) of the three groups of data > α (0.05). This showed that the three groups are homogeneous.

Hypotesis Test

Table 4. Linierity Test Results

No	Var.	Sig. Score	P _{Provision}
1	X ₁ *Y	0,001	0,05
2	X ₂ *Y	0,027	0,05
3	X ₁ and X ₂ *Y	0,000	0,05

X₁ = locus of control
 X₂ = personal responsibility
 Y = pro-environmental intention

Based on Table 4. The linierity test results in all three groups of data indicated sig score. Significance value (p) of the three groups of data < α (0.05). This showed that the three groups are linier.

Table 5. Regression Analysis Results

Model	Constant	B	Sig.
X ₁ Y	60,770	0,275	0,001
X ₂ Y	61,910	0,191	0,027

X₁ = locus of control
 X₂ = personal responsibility
 Y = pro-environmental intention

Based on these data, the regression equation model formed between X₁ with Y and X₂ with Y is $\hat{Y} = 60,770 + 0,275X_1$ and $\hat{Y} = 61,910 + 0,191X_2$.

Regression equation models can be illustrated in Figure 3.

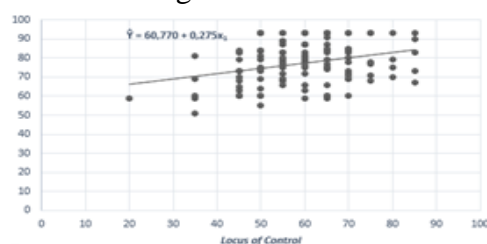

(a) Locus of Control

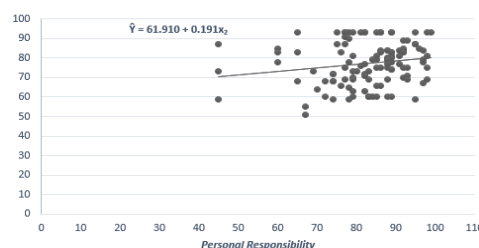

(b) Personal Responsibility

Figure 3. Linierity Model

Table 6. Multiple Regression Analysis Results

Model	Constant	B	B	Sig.
X ₁ X ₂ Y	48,011	0,263	0,170	0,000

X₁ = locus of control
 X₂ = personal responsibility
 Y = pro-environmental intention

From on the data obtained, the significance value is smaller than alpha, which is 0,000 < 0,05, so that the data is. The multiple regression equation model obtained is $\hat{Y} = 48,011 + 0,263X_1 + 0,170X_2$. The equation can then be interpreted if there is an increase in 1 score locus of control and personal responsibility then it will be followed by an increase in the pro-environmental intention of 0.263 and 0.170 in the constant 46.011 through the regression model \hat{Y} .

Correlation Test

The correlation analysis test used the Pearson Product Moment test.

Table 7. Correlation Test Results

		X ₁	X ₂	Y
X ₁	Pearson Correlation	1	,077	,309
	Sig. (2-tailed)		,405	,001
	N	120	120	120
X ₂	Pearson Correlation	,077	1	,202
	Sig. (2-tailed)	,405		,027
	N	120	120	120
Y	Pearson Correlation	,309	,202	1
	Sig. (2-tailed)	,001	,027	
	N	120	120	120

X₁ = locus of control
 X₂ = personal responsibility
 Y = pro-environmental intention

Based on the calculations obtained that the correlation coefficient between locus of control and pro-environmental intention is 0.309. The value of $r_{x_1y} = 0.309$ indicates that there is a positive correlation. The correlation coefficient between personal responsibility and pro-environmental intention is 0.202. The value of $r_{x_2y} = 0.202$ indicates that there is a positive correlation.

Table 8. Multiple Correlation Test Results

Model	R	R Square	Adjusted R Square	Sig. F Change
X ₁ X ₂ Y	,357 ^a	,127	,112	,000

X₁ = locus of control

X₂ = personal responsibility
 Y = pro-environmental intention

The multiple correlation coefficient between locus of control and personal responsibility together with pro-environmental intention is 0.357, which means there is a positive correlation.

Discussion

Students with internal locus of control hold internal factors responsible for their success or failure and as a result, students become more independent in deciding their own desires. In addition, according to Weimer, Ahlström, & Lisspers (2017) students with internal locus of control believe they can control life events because their behavior is determined by internal factors such as hard work, decision making, problem solving skills, effort, and persuasion.

Students with internal locus of control tend to view and believe the events that occur in the environment caused by their actions so that the desires and behaviors of these students are more responsible for the environment. The results of this study are relevant to the findings of Yang, Lin, & Liu, (2016), there is a significant relationship between locus of control and pro-environmental intention, that students who can control what is happening have higher desires and behaviors to care towards norms and values that exist in the environment.

Students with internal locus of control tend to change their behavior easily to achieve their desires, effective personal efforts for the results. Students show that the more effort they make, the greater the success. Students with internal locus of control have a higher likelihood of success compared to students with external locus of control who rely on luck (Angelova, 2016).

Locus of control contributes to the pro-environmental intention of students because of internal factors that exist within themselves, so that they are able to determine the desire to act which can affect the environmentally responsible behavior of

the student. For example, if the student wants to decide something, students who have internal Locus of control choose a decision of their own choosing. Bamberg & Moser, (2007), also argue that there is a significant relationship between locus of control and pro-environmental intention, the Personality Factor (Attitude, Locus of Control and Personal Responsibility) as one of the pro-environmental intention predictors that leads to pro environment or environmentally responsible behavior in accordance with the model of responsible behavior of the Hines environment.

Personal responsibility for the environment is the belief of a student to fulfill obligations and reduce consequences by not blaming the circumstances of the actions he made on the environment so that the existence of high personal responsibility within the student can improve the pro-environmental intention or the desire of students itself to care about the surrounding environment. The results of this study were also supported by the findings of Pan, Chou, Morrison, & Lin, (2018), who argued that personal responsibility for the environment had an influence on one's desires which had an effect on the behavior of the environment itself.

Students who have high personal responsibility are able to learn how to respect the rights and feelings of others, decide their own desires and the importance of being responsible. The results of this study are relevant to those proposed by Ernst, Blood, & Beery, (2015), that students who have high personal responsibility can develop sensitivity to others (including compassion, empathy and interpersonal skills) and the ability to apply learning throughout programs into wider life (eg schools, homes).

Students who have high personal responsibility are able to become independent learners, able to play an active role in learning and their desire to be more responsible. According to Mergler & Shield, (2016), Students with high Personal Responsibility are able to become confident

individuals, more responsible and creative desires including the ability to make rational and informed decisions about their lives and accept responsibility for their actions.

Students who have personal responsibility, when choosing among various choices, the student respects decisions that have been chosen along with their consequences. Decisions based on students themselves are more likely to consider carefully before doing so. Personal responsibility has four key components, namely: (1) awareness and control of individual thoughts and feelings; (2) awareness and control over choices made; (3) willingness to be responsible for the behavior that has been done; and (4) awareness and concern for the impact of one's behavior on others (Mergler, 2016).

Locus of control and personal responsibility contribute to students' pro-environmental intentions because of internal factors within students who tend to believe that their success comes from their own efforts and have high personal responsibility to protect the environment, thus guiding students to want to care for the environment. The results of this study are relevant to Talens, (2016), that personality factors, namely attitude, locus of control and personal responsibility have a significant relationship with the pro-environmental intention so that it has an effect on environmental care behavior. Hwang, Kim, & Jeng, (2010) study, which found the influence of locus of control on the pro-environmental intention.

Palupi & Sawitri, (2018) suggest that teenagers who have high personal responsibility have more desire to care about the environment. Also, Rahman, (2016) argues that personal responsibility is a factor that influences one's desire to care about the environment.

CONCLUSION

This study aims to determine whether there is a significant relationship between locus of control and personal responsibility

with pro-environmental intention on students XI MIPA at SMAN 8 Makassar. Based on the results of research and discussion, it can be concluded that locus of control and personal responsibility have a significant positive relationship with the pro-environmental intention of XI MIPA students at SMAN 8 Makassar.

The researcher gives suggestions to the next researcher to conduct research on the relationship of locus of control with personal responsibility in various universities or colleges, regions and fields or departments that exist. It is also useful to compare findings with other universities or colleges in various regions.

For teachers, it is better to provide a stimulus that can stimulate the locus of control and personal responsibility of students so that the locus of control that is internal and personal responsibility possessed by students is higher and can improve the pro-environmental intention of the student. For students, it is better to increase locus of control that is internal and personal responsibility, so that it can improve the pro-environmental intention.

ACKNOWLEDGMENT

I would like to thank Dr. Mieke Miarsyah, M.Si and Dr. Rusdi, M. Biomed for feedback on earlier drafts of this manuscript, and for continued mentoring and support.

REFERENCES

- Angelova, N. V. (2016). Locus of control and its relationship with some social-demographic factors. *Psychological Thought*, 9(2), 248–258. <https://doi.org/10.5964/psyct.v9i2.179>
- Bamberg, S., & Moser, G. (2007). Twenty years after hines, hungerford, and tomera: A new meta-analysis of psycho-social determinants of pro-environmental behaviour. *Journal of Environmental Psychology*, 27, 14–25.
- Erkan, K. (2015). The relationship between locus of control and perfectionism perception of the primary school administrators. *Procedia-Social and Behavioral Sciences*, 174, 3893–3902. <https://doi.org/10.1016/j.sbspro.2015.01.1130>
- Ernst, J., Blood, N., & Beery, T. (2015). Environmental action and student environmental leaders: exploring the influence of environmental attitudes, locus of control, and sense of personal responsibility. *Environmental Education Research*, 4622, 1–27. <https://doi.org/10.1080/13504622.2015.1068278>
- Hines, J. M., Hungerford, H. R., & Tomera, A. N. (2010). Analysis and synthesis of research on responsible environmental behavior: A meta-analysis. *The Journal of Environmental Education*, 18(2), 1–8.
- Hwang, Y.-H., Kim, S.-I., & Jeng, J.-M. (2010). Examining the causal relationships among selected antecedents of responsible environmental behavior. *The Journal of Environmental Education*, 31(4), 19–25. <https://doi.org/10.1080/00958960009598647>
- Keshavarz, M., & Karami, E. (2016). Farmers' pro-environmental behavior under drought: Application of protection motivation theory. *Journal of Arid Environments*, 127, 128–136. <https://doi.org/10.1016/j.jaridenv.2015.11.010>
- Mergler, A. (2007). Adolescents talking about personal responsibility. *Journal of Student Wellbeing*, 1(1), 57–70.

- Mergler, A. (2016). Personal responsibility: an integrative review of conceptual and measurement issues of the construct. *Research Papers in Education, 1522*, 1–14.
<https://doi.org/10.1080/02671522.2016.1225801>
- Mergler, A., & Shield, P. (2016). Development of the personal responsibility scale for adolescents. *Journal of Adolescence, 51*, 50–57.
<https://doi.org/10.1016/j.adolescence.2016.05.011>
- Mergler, A., Spencer, F., & Patton, W. (2008). Personal responsibility: the creation, implementation and evaluation of a school-based program. *Journal of Student Wellbeing, 2*(1), 35–51.
- Palupi, T., & Sawitri, D. R. (2018). The importance of pro-environmental behavior in adolescent. *E3S Web of Conferences, 9*(31), 2–5.
- Pan, S., Chou, J., Morrison, A. M., & Lin, M. (2018). Will the future be greener? the environmental behavioral intentions of university tourism students. *Journal of MDPI, 634*(1), 1–17.
<https://doi.org/10.3390/su10030634>
- Rahman, N. (2016). Knowledge, internal, and environmental factors on environmental care behaviour among aboriginal students in malaysia. *International Journal of Environmental & Science Education, 11*(12), 5349–5366.
- Rucas, S. L., & Miller, A. A. (2013). Locus of control and sleep in evolutionary perspective. *Journal of Social, Evolutionary, and Cultural Psychology, 7*(2), 79–96.
<https://doi.org/10.1037/h0099208>
- Steg, L., & Vlek, C. (2009). Encouraging pro-environmental behaviour: An integrative review and research agenda. *Journal of Environmental Psychology, 29*(3), 309–317.
<https://doi.org/10.1016/j.jenvp.2008.10.004>
- Talens, J. D. (2016). Development and validation of responsible environmental behavior scale towards solid waste management (REBS-SWM) in school setting. *International Journal of Advanced Engineering, Management and Science (IJAEMS), 2*(4), 191–197.
- Weimer, K., Ahlström, R., & Lisspers, J. (2017). Values, attitudes, moral judgment competence, locus of control and sense of coherence as determinants of pro-environmental behaviors and behavioral intentions. *Journal of Multidisciplinary Engineering Science and Technology (JMEST), 4*(5), 2568–2583.
- Yang, J. C., Lin, Y. L., & Liu, Y. (2016). Effects of locus of control on behavioral intention and learning performance of energy knowledge in game-based learning. *Journal of Environmental Education Research, 4622*, 1–14.
<https://doi.org/10.1080/13504622.2016.1214865>