



Kettering University
Digital Commons @ Kettering University

Mechanical Engineering Patents

Mechanical Engineering

1-2014

Assembly of Bifurcation and Trifurcation Bipolar Plate to Design Fuel Cell Stack

Susanta K. Das
Kettering University, sdas@kettering.edu

Jayesh Kavathe

Kingsley Joel Berry
Kettering University, jberry@kettering.edu

Follow this and additional works at: https://digitalcommons.kettering.edu/mech_eng_patents

 Part of the [Mechanical Engineering Commons](#)

Recommended Citation

Das, Susanta K.; Kavathe, Jayesh; and Berry, Kingsley Joel, "Assembly of Bifurcation and Trifurcation Bipolar Plate to Design Fuel Cell Stack" (2014). *Mechanical Engineering Patents*. 13.
https://digitalcommons.kettering.edu/mech_eng_patents/13

This Patent is brought to you for free and open access by the Mechanical Engineering at Digital Commons @ Kettering University. It has been accepted for inclusion in Mechanical Engineering Patents by an authorized administrator of Digital Commons @ Kettering University. For more information, please contact digitalcommons@kettering.edu.

(54) **ASSEMBLY OF BIFURCATION AND TRIFURCATION BIPOLAR PLATE TO DESIGN FUEL CELL STACK**

(76) Inventors: **Susanta K. Das**, Grand Blanc, MI (US); **Jayesh Kavathe**, Flint, MI (US); **K. Joel Berry**, Flint, MI (US)

(*) Notice: Subject to any disclaimer, the term of this patent is extended or adjusted under 35 U.S.C. 154(b) by 393 days.

(21) Appl. No.: **12/783,099**

(22) Filed: **May 19, 2010**

(65) **Prior Publication Data**

US 2010/0297516 A1 Nov. 25, 2010

Related U.S. Application Data

(60) Provisional application No. 61/179,801, filed on May 20, 2009.

(51) **Int. Cl.**
H01M 8/04 (2006.01)

(52) **U.S. Cl.**
USPC **429/434**; 429/400; 429/401; 429/405; 429/452; 429/454; 429/455; 429/456; 429/457; 429/458; 429/459; 429/460; 429/461; 429/467; 429/468; 429/469; 429/470; 429/471; 429/479; 429/483; 429/484; 429/492; 429/502; 429/535

(58) **Field of Classification Search**
USPC 429/434, 400, 428, 452, 467, 468, 471, 429/401, 469, 479, 483, 535, 492, 405, 454, 429/455-461, 168, 470, 484, 502

See application file for complete search history.

(56) **References Cited**

U.S. PATENT DOCUMENTS

6,844,101	B2	1/2005	Lee et al.	
6,936,369	B1	8/2005	Komura et al.	
6,951,698	B2	10/2005	King	
7,018,733	B2	3/2006	Sugiura et al.	
7,067,213	B2	6/2006	Boff et al.	
7,524,575	B2	4/2009	Bai et al.	
2002/0192531	A1	12/2002	Zimmerman et al.	
2003/0068541	A1*	4/2003	Sugiura et al.	429/26
2003/0203260	A1*	10/2003	Lee	429/26
2003/0215695	A1	11/2003	Suzuki et al.	
2004/0048141	A1*	3/2004	Blank et al.	429/38
2005/0074872	A1	4/2005	Furino et al.	
2006/0134502	A1	6/2006	Garceau	
2007/0042257	A1	2/2007	Chyou et al.	

(Continued)

Primary Examiner — Jeffrey Wollschlager

Assistant Examiner — Stella Yi

(74) *Attorney, Agent, or Firm* — Dickinson Wright, PLLC

(57) **ABSTRACT**

A current producing cell has anode flow plates **22** and cathode flow plates **20**. Each of the flow plates **20**, **22** defines a membrane face **26**, a collector face **24**, and a center axis C perpendicular to the membrane face **26** and the collector face **24**. Each of the collector faces **24** define a plurality of cooling channels **74**, **76**, **78** and a plurality of transport channels **62**, **64**. The cooling channels **74**, **76**, **78** of the cathode flow plates **20** extend radially relative to the center axis C thereof to overlap the transport channels **62**, **64** of the anode flow plates **22**. The cooling channels **74**, **76**, **78** of the anode flow plates **22** extend radially relative to the center axis C thereof to overlap the transport channels **62**, **64** of the cathode flow plates **20** for providing cooling axially between the cooling channels **74**, **76**, **78** of the anode flow plate **22** to the transport channels **62**, **64** of the cathode flow plate **20** and between the cooling channels **74**, **76**, **78** of the cathode flow plate **20** to the transport channels **62**, **64** of the anode flow plate **22**.

20 Claims, 3 Drawing Sheets

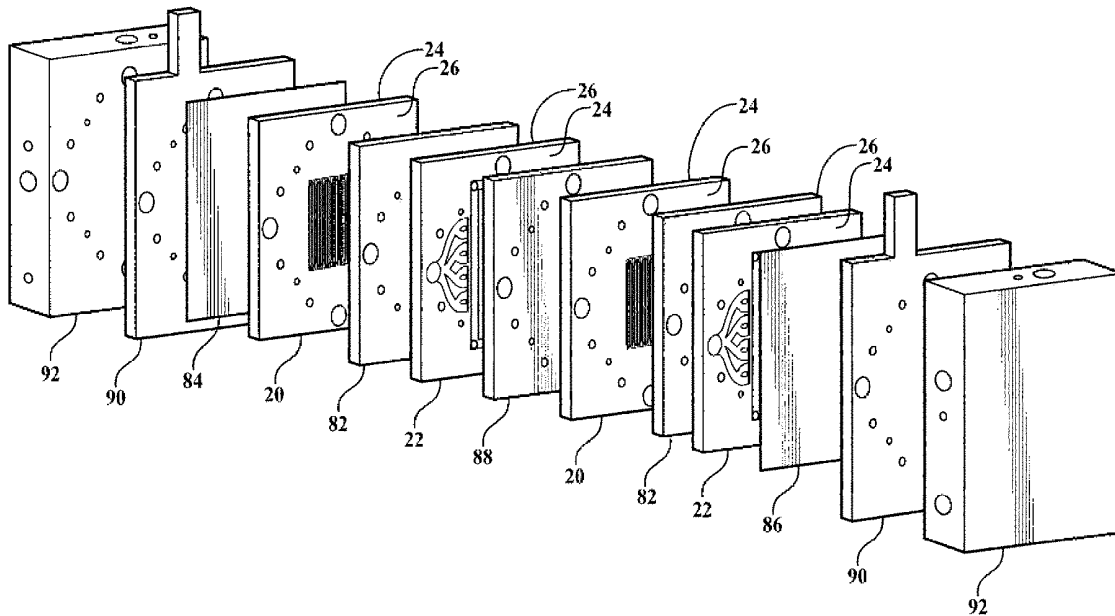

(56)

References Cited

U.S. PATENT DOCUMENTS

2007/0202383 A1 8/2007 Goebel
2007/0207363 A1 9/2007 Chyou et al.

2008/0254339 A1 10/2008 Owejan et al.
2008/0318115 A1 12/2008 Wang et al.
2009/0075154 A1 3/2009 Madeleine et al.
2009/0286133 A1 11/2009 Trabold et al.

* cited by examiner

FIG. 1

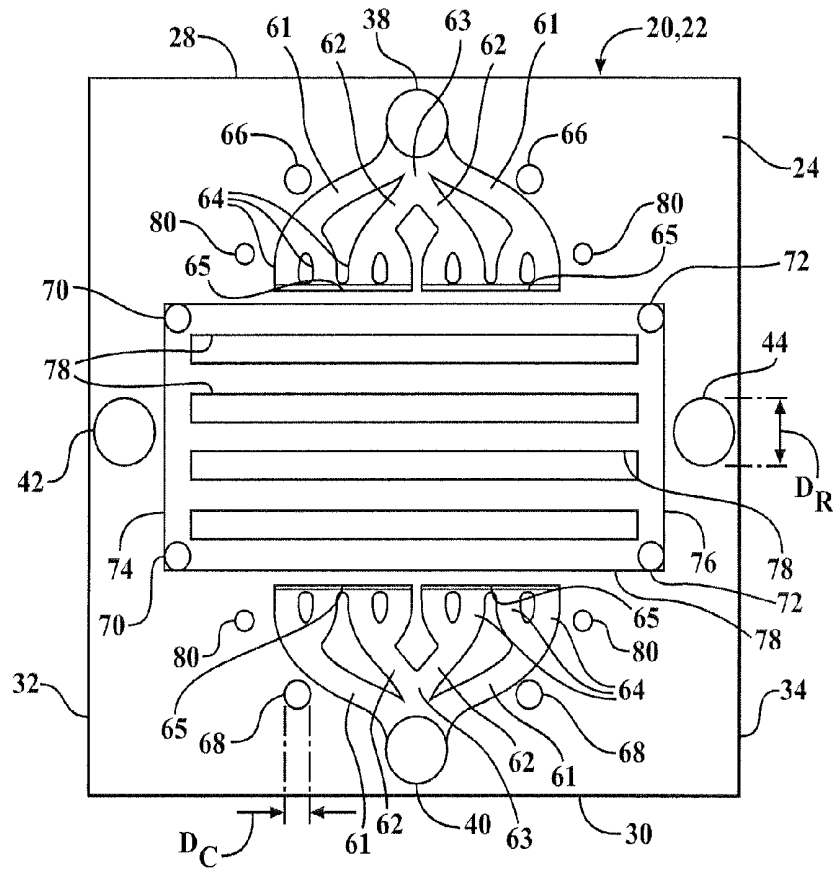
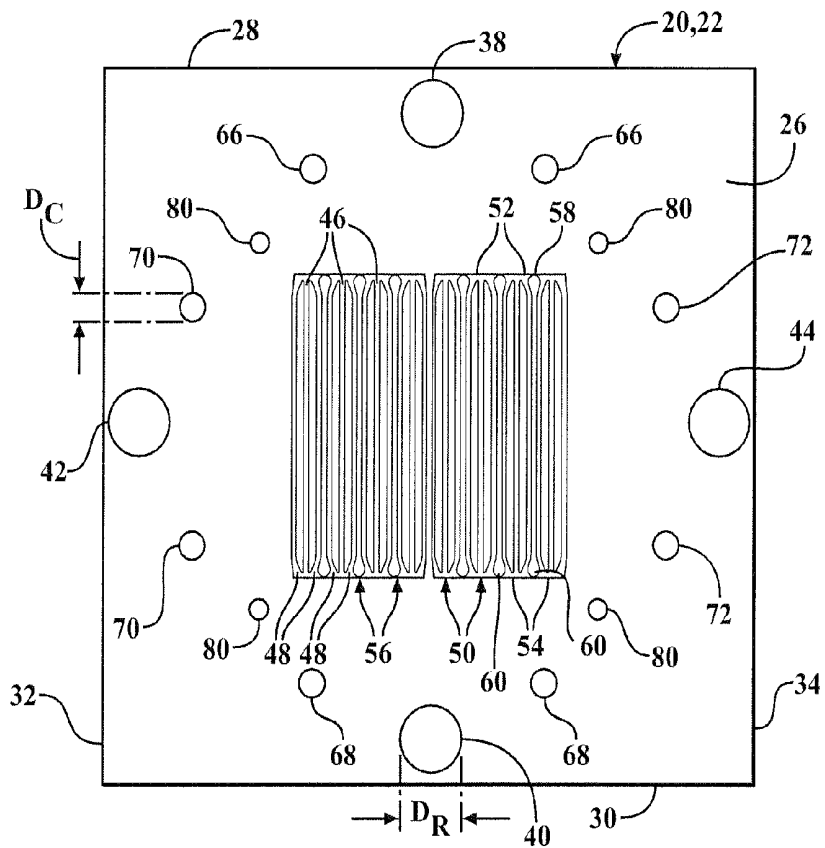

FIG. 2



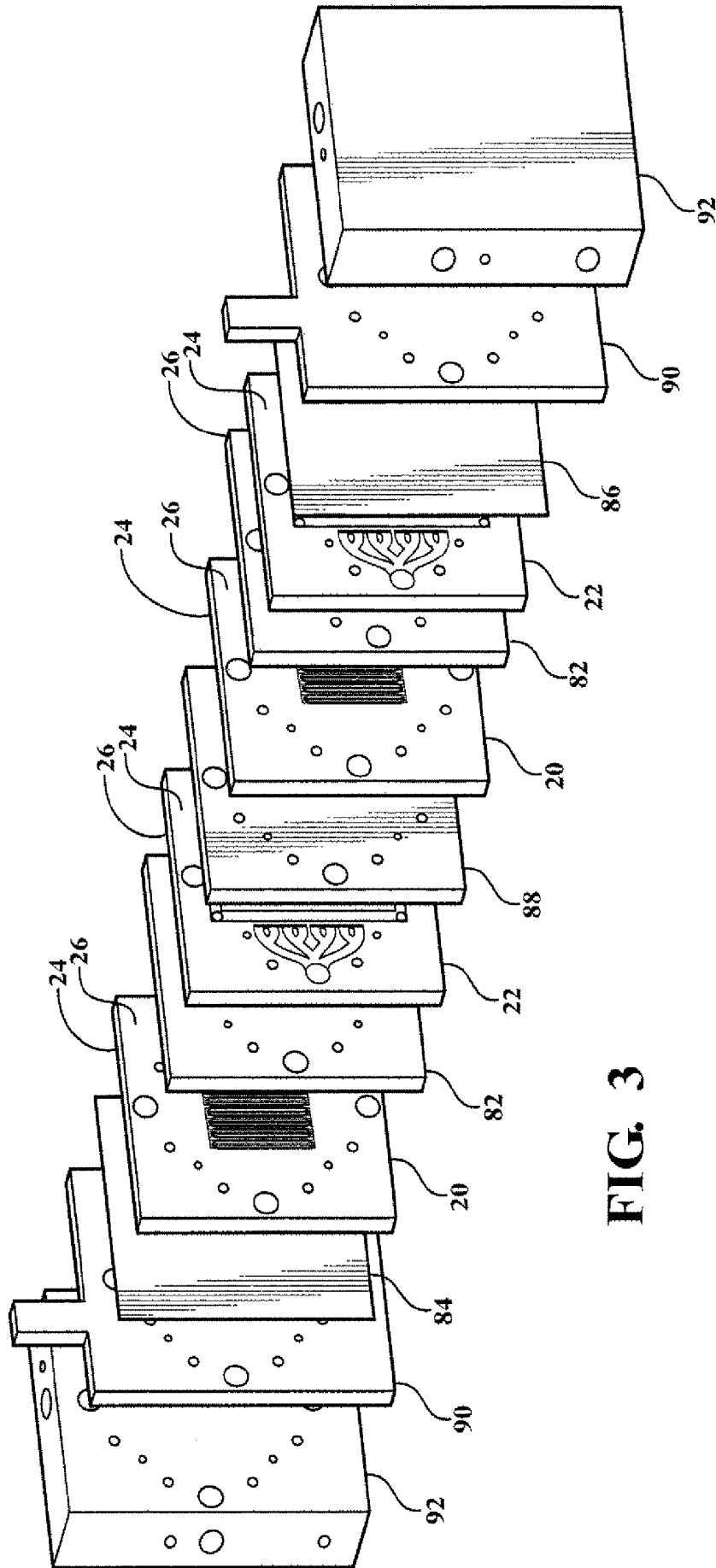
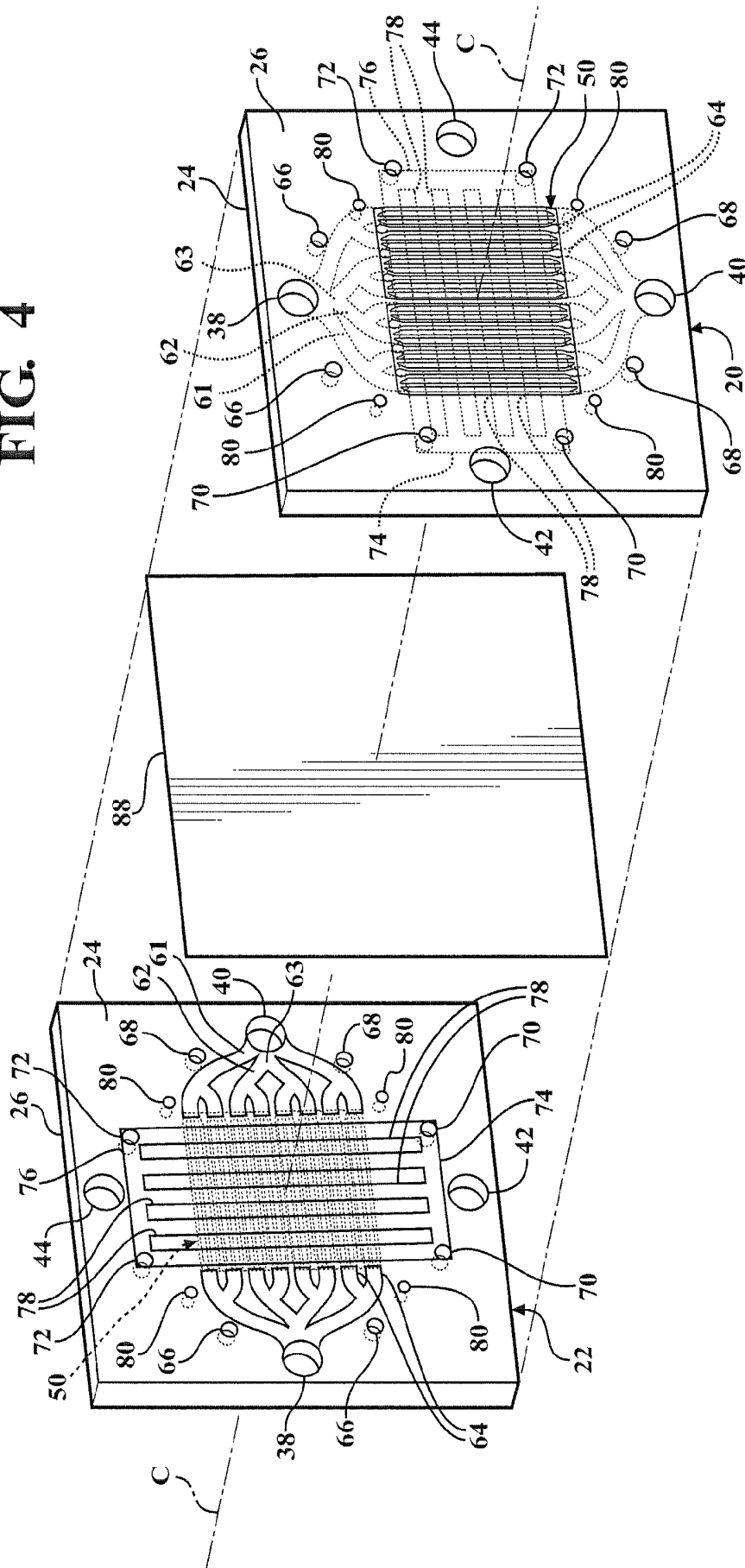

FIG. 3

FIG. 4



ASSEMBLY OF BIFURCATION AND TRIFURCATION BIPOLAR PLATE TO DESIGN FUEL CELL STACK

CROSS REFERENCE TO RELATED APPLICATION

This application claims the benefit of application Ser. No. 61/179,801 filed May 20, 2009.

BACKGROUND OF THE INVENTION

1. Field of the Invention

A fuel cell that produces electrical current.

2. Description of the Prior Art

Current producing fuel cells are well known in the prior art. U.S. Pat. No. 7,018,733 to Seguirá, for example, discloses a cathode flow plate and an anode flow plate parallel to the cathode flow plate. Each of the flow plates defines a collector face and a membrane face. Each of the collector faces defines a plurality of cooling channels. Each of the membrane faces defines a plurality of active channels for presenting fluid for reaction. One of the collector face and the membrane face of each of the flow plates defines a plurality of transport channels for moving fluid to and from the active channels. Each of the flow plates defines a center axis extending centrally therethrough and perpendicular to the membrane face and the collector face.

SUMMARY OF THE INVENTION AND ADVANTAGES

The invention provides for the cooling channels of the cathode flow plates extending radially relative to the central axis thereof to overlap the transport channels of the anode flow plates and the cooling channels of the anode flow plates extending radially relative to the central axis thereof to overlap the transport channels of the cathode flow plates for providing cooling axially between the cooling channels of the anode flow plate to the transport channels of the cathode flow plate and between the cooling channels of the cathode flow plate to the transport channels of the anode flow plate.

ADVANTAGES OF THE INVENTION

The complementary arrangement of the channels of the subject invention improves the flow of fluids through the transport and active channels of both anode flow plates and cathode flow plates.

BRIEF DESCRIPTION OF THE DRAWINGS

Other advantages of the present invention will be readily appreciated, as the same becomes better understood by reference to the following detailed description when considered in connection with the accompanying drawings wherein:

FIG. 1 is a front view of a flow plate according to the present invention;

FIG. 2 is a rear view of a flow plate according to the present invention;

FIG. 3 is an exploded perspective view of a fuel cell that produces current according to the present invention; and

FIG. 4 is an exploded perspective view of two flow plates and a seal according to the present invention.

DETAILED DESCRIPTION OF THE INVENTION

Referring to the Figures, wherein like numerals indicate corresponding parts throughout the several views, a fuel cell

stack includes a plurality of flow plates **20**, **22**. Each of the flow plates **20**, **22** defines a collector face **24** and a membrane face **26** parallel to the collector face **24**. Each of the flow plates **20**, **22** has an inlet edge **28** and an outlet edge **30** parallel to the inlet edge **28**. The inlet edge **28** and the outlet edge **30** are interconnected by a first bypass edge **32** perpendicular to the inlet edge **28** and the outlet edge **30**, and a second bypass edge **34** parallel to the first bypass edge **32** to define a square perimeter. Each of the flow plates **20**, **22** define a center axis **C** extending centrally therethrough and perpendicular to the membrane face **26** and the collector face **24**.

Each of the flow plates **20**, **22** defines four reactant holes **44**, **38**, **40**, **42** extending therethrough perpendicular to the membrane face **26** and the collector face **24**. Each of the reactant holes **44**, **38**, **40**, **42** has a reactant hole diameter D_R , and the reactant hole diameters D_R are equal. Each of the reactant holes **44**, **38**, **40**, **42** are radially spaced inwardly from a different one of the edges **28**, **30**, **32**, **34** by an equal distance. The reactant holes **44**, **38**, **40**, **42** include an inlet hole **38** adjacent and inward from the inlet edge **28** and midway between the first bypass edge **32** and the second bypass edge **34**. The reactant holes **44**, **38**, **40**, **42** include an outlet hole **40** radially opposite the inlet hole **38** and adjacent and inward from the outlet edge **30** and midway between the first bypass edge **32** and the second bypass edge **34**. The reactant holes **44**, **38**, **40**, **42** include a first bypass hole **42** adjacent and inward from the first bypass edge **32** and midway between the inlet edge **28** and the outlet edge **30** and disposed ninety degrees from the inlet hole **38** about the center axis **C**. The reactant holes **44**, **38**, **40**, **42** including a second bypass hole **44** radially opposite the first bypass hole **42** and adjacent and inward from the second bypass edge **34** and midway between the inlet edge **28** and the outlet edge **30**.

The membrane face **26** of each of the flow plates **20**, **22** defines a plurality of active channels **46**, **48** extending into the membrane face **26** for presenting fluid for reaction. The active channels **46**, **48** are divided into channel sets **50**. Each of the channel sets **50** include an inlet-side manifold **52** and an outlet-side manifold **54** and three of the active channels **46**, **48** interconnecting the manifolds **52**, **54**. Each of the channel sets **50** include a middle active channel **46** extending perpendicular to the inlet edge **28**. The three active channels **46**, **48** of each channel set **50** include a pair of diverging active channels **48** disposed adjacent the middle active channel **46** and diverging in opposite directions from the middle active channel **46** and the inlet-side manifold **52** and then parallel with the middle active channel **46** and converging into the outlet-side manifold **54** with the middle active channel **46**.

The membrane face **26** of each of the flow plates **20**, **22** presents a plurality of ribs **56** each disposed between two adjacent of the channel sets **50**. Each rib **56** defines an inlet head **58** and an outlet head **60**, each being bulbous and interconnected by a straight section parallel to the first bypass edge **32**.

Each of the flow plates **20**, **22** defines a first plurality of transport channels including four branches **61**, **62** and eight sub-branches **64** for moving fluid to the inlet-side manifolds **52** of the channel sets **50** from the inlet hole **38**. The inlet hole (**38**) of each of the flows plates (**20**, **22**) is trifurcated into a pair of outer branches (**61**) and one stem (**63**). The one stem (**63**) is disposed between the pair of outer branches (**61**) and is bifurcated into two inner branches (**62**). Each of the branches (**61**, **62**) extending from the inlet hole (**38**) is bifurcated into a pair of the sub-branches (**64**). Each of the flow plates **20**, **22** defines a second plurality of transport channels including four of the branches **61**, **62** and eight of the sub-branches **64** for moving fluid from the outlet-side manifolds **54** of the channel

sets **50** to the outlet hole **40**. The outlet hole (**40**) of each of the flow plates (**20, 22**) is trifurcated into a pair of outer branches (**61**) and one stem (**63**). The one stem (**63**) is disposed between the pair of outer branches (**61**) and is bifurcated into two inner branches (**62**). Each of the branches (**61, 62**) extending from the outlet hole (**40**) is bifurcated into a pair of the sub-branches (**64**). Each of the branches **61, 62** extends from one of the inlet hole **38** and the outlet hole **40** and is in fluid communication with two of the sub-branches **64**. Each of the sub-branches **64** in fluid communication with one of the manifolds **52, 54** of one of the channel sets **50** of the flow plate **20, 22** thereof. The inner branches **62** have a combined minimal cross-sectional flow area that is less than the combined minimal cross-sectional flow area of the outer branches **61**.

Each of the flow plates **20, 22** define a plurality of slots **65** each interconnecting adjacent of the sub-branches **64**. One of the slots **65** is adjacent each of the heads **58, 60**.

Each of the flow plates **20, 22** defines a plurality of coolant holes **68, 70, 72, 66** extending therethrough perpendicular to the membrane and collector faces **26, 24** and having coolant hole diameters D_c being equal. The coolant holes **68, 70, 72, 66** include two inlet-side coolant holes **66** inward from and on either side of the inlet hole **38** and two outlet-side coolant holes **68** inward from and on either side of the outlet hole **40** and two first bypass-side coolant holes **70** inward from and on either side of the first bypass hole **42** and two second bypass-side coolant holes **72** inward from and on either side of the second bypass hole **44**.

Each of the collector faces **24** defines a plurality of cooling channels **74, 76, 78**. The cooling channels **74, 76, 78** include a first bypass-side cooling channel **74** extending between the first bypass-side coolant holes **70** and parallel to the first bypass edge **32**. The cooling channels **74, 76, 78** include a second bypass-side cooling channel **76** extending between the second bypass-side coolant holes **72** and parallel to the first bypass-side cooling channel **74**. The cooling channels **74, 76, 78** include a plurality of transverse cooling channels **78** extending perpendicular to and between the first bypass-side cooling channel **74** and the second bypass-side cooling channel **76**.

Each of the flow plates **20, 22** define a plurality of alignment holes **80** extending therethrough perpendicular to the collector face **24** and the membrane face **26** thereof. One of the alignment holes **80** is between the inlet hole **38** and the second bypass hole **44**. Another of the alignment holes **80** is between the second bypass hole **44** and the outlet hole **40**. Another of the alignment holes **80** is between the outlet hole **40** and the first bypass hole **42**. Another of the alignment holes **80** is between the first bypass hole **42** and the inlet hole **38**.

The flow plates **20, 22** include a plurality of cathode flow plates **20** each having the membrane face **26** thereof facing a common direction and the center axes **C** thereof being coaxial. Each of the cathode flow plates **20** is disposed one of ninety degrees and one hundred eighty degrees from each other of the cathode flow plates **20** about the center axis **C**.

The flow plates **20, 22** include a plurality of anode flow plates **22** each having the membrane face **26** thereof facing in the opposite direction as the membrane face **26** of each of the cathode flow plates **20** and the center axes **C** thereof being coaxial.

Each of the anode flow plates **22** is disposed one of ninety degrees and two-hundred seventy degrees from each of the cathode flow plates **20** to align the inlet hole **38** of each of the anode flow plates **22** with one of the first bypass hole **42** and the second bypass hole **44** of each of the cathode flow plates **20** and align the first bypass hole **42** of each of the anode flow plates **22** with one of the outlet hole **40** and inlet hole **38** of

each of the cathode flow plates **20** and align the outlet hole **40** of each of the anode flow plates **22** with one of the second bypass holes **44** and first bypass holes **42** of each of the cathode flow plates **20** and align the second bypass hole **44** of each of the anode flow plates **22** with one of the inlet hole **38** and outlet hole **40** of each of the cathode flow plates **20** and align each of the coolant holes **68, 70, 72, 66** of each of the cathode flow plates **20** with one of the coolant holes **68, 70, 72, 66** of each of the anode flow plates **22** and align each of the alignment holes **80** of each of the cathode flow plates **20** with one of the alignment holes **80** of each of the anode flow plates **22**.

A plurality of membrane electrode assemblies **82** for collecting and conducting protons therethrough each present an anode face being clamped against the membrane face **26** of one of the anode flow plates **22**. Each of the membrane electrode assemblies **82** present a cathode face opposite and parallel the anode face and clamped against the membrane face **26** of one of the cathode flow plates **20**.

A plurality of seals **84, 86, 88** each for conducting electricity and preventing migration of fluid therethrough include a cathode end seal **84** being disposed against the collector face **24** of one the cathode flow plates **20**. The seals **84, 86, 88** include an anode end seal **86** being disposed against the collector face **24** of one of the anode flow plates **22**. The seals **84, 86, 88** include a plurality of intermediate seals **88** each being disposed against the collector face **24** of one the cathode flow plates **20** and the collector face **24** of one the anode plate.

A pair of collector plates **90** each abuts one of the end seals **84, 86**. A pair of end plates **92** each abuts one of the collector plates **90**.

The cooling channels **74, 76, 78** of the cathode flow plates **20** extend radially relative to the center axis **C** thereof to overlap the branches **61, 62**, and sub-branches **64** of the anode flow plates **22** and the cooling channels **74, 76, 78** of the anode flow plates **22** extend radially relative to the center axis **C** thereof to overlap the branches **61, 62**, and sub-branches **64** of the cathode flow plates **20** for providing cooling axially between the cooling channels **74, 76, 78** of the anode flow plate **22** to the branches **61, 62**, and sub-branches **64** of the cathode flow plate **20** and between the cooling channels **74, 76, 78** of the cathode flow plate **20** to the branches **61, 62**, and sub-branches **64** of the anode flow plate **22**.

In an embodiment of the invention, the inlet holes **38** of each of the cathode flow plates **20** are coaxial, and the inlet holes **38** of each of the anode flow plates **22** are coaxial and disposed ninety degrees from the inlet holes **38** of the cathode flow plates **20** about the center axes **C** to align the inlet hole **38** of each of the anode flow plates **22** with the first bypass hole **42** of each of the cathode flow plates **20** and align the first bypass hole **42** of each of the anode flow plates **22** with the outlet hole **40** of each of the cathode flow plates **20** and align the outlet hole **40** of each of the anode flow plates **22** with the second bypass holes **44** of each of the cathode flow plates **20** and align the second bypass hole **44** of each of the anode flow plates **22** with the inlet hole **38** of each of the cathode flow plates **20** for parallel distribution of fluid to the active channels **46, 48** of the flow plates **20, 22**.

In another embodiment, the inlet holes **38** of each of the cathode flow plates **20** are coaxial with every other one of the other of the cathode flow plates **20**, and the inlet holes **38** of each of the anode flow plates **22** is coaxial with every other one of the other of the flow plates **20, 22** for series of distribution of fluid to the active channels **46, 48** of the flow plates **20, 22**.

Obviously, many modifications and variations of the present invention are possible in light of the above teachings and may be practiced otherwise than as specifically described while within the scope of the appended claims. The use of the word "said" in the apparatus claims refers to an antecedent that is a positive recitation meant to be included in the coverage of the claims whereas the word "the" precedes a word not meant to be included in the coverage of the claims. In addition, the reference numerals in the claims are merely for convenience and are not to be read in any way as limiting.

What is claimed is:

1. A fuel cell stack comprising:

at least one cathode flow plate (20) and at least one anode flow plate (22) parallel to said at least one cathode flow plate (20),

each of said flow plates (20, 22) presenting a collector face (24) and a membrane face (26) parallel to and facing opposite said collector face (24),

each of said flow plates (20, 22) defining an inlet hole (38) and an outlet hole (40) each extending perpendicular to said membrane face (26) and said collector face (24) for distributing and collecting fluid,

said collector face (24) of each of said flow plates (20, 22) defining outer branches (61) and inner branches (62) and stems (63) and sub-branches (64) for conveying fluid said inlet hole (38) of each of said flow plates (20, 22) being trifurcated into a pair of said outer branches (61) and one of said stems (63), wherein said one stem (63) is disposed between said pair of outer branches (61), said one stem (63) is bifurcated into two of said inner branches (62), and each of said branches (61, 62) extending from said inlet hole (38) is bifurcated into a pair of said sub-branches (64),

said outlet hole (40) of each of said flow plates (20, 22) being trifurcated into a pair of said outer branches (61) and one of said stems (63), wherein said one stem (63) is disposed between said pair of outer branches (61), said one stem (63) is bifurcated into two of said inner branches (62), and each of said branches (61, 62) extending from said outlet hole (40) is bifurcated into a pair of said sub-branches (64),

said membrane face (26) of each of said flow plates (20, 22) defining a plurality of inlet-side manifolds (52), wherein each one of said inlet-side manifolds (52) is disposed along and in fluid communication with one of said sub-branches (64) extending from said inlet hole (38),

said membrane face (26) of each of said flow plates (20, 22) defining a plurality of outlet-side manifolds (54), wherein each one of said outlet-side manifolds (54) is disposed along and in fluid communication with one of said sub-branches (64) extending from said outlet hole (40),

said membrane face (26) of each of said flow plates (20, 22) defining a plurality of active channels (46, 48) interconnecting said inlet-side manifolds (52) and said outlet-side manifolds (54), wherein each one of said inlet-side manifolds (52) is trifurcated into three of said active channels (46, 48), and said three active channels (46, 48) interconnect said inlet-side manifold (52) with one of said outlet-side manifolds (52).

2. A fuel cell stack as set forth in claim 1 wherein said inner branches (62) have a combined minimal cross-sectional flow area less than the combined minimal cross-sectional flow area of said outer branches (61).

3. A fuel cell stack as set forth in claim 1 including a plurality of said cathode flow plates (20) and a plurality of said anode flow plates (22) and wherein

each of said collector faces (24) defines a plurality of cooling channels (74, 76, 78),

each of said flow plates (20, 22) defines a center axis (C) extending centrally therethrough and perpendicular to said membrane face (26) and said collector face (24),

each of said membrane faces (26) of said cathode flow plates (20) axially faces a common direction and each of said membrane faces (26) of said anode flow plates (22) axially faces in the opposite direction as said membrane faces (26) of each of said cathode flow plates (20),

each of said flow plates (20, 22) defines a plurality of reactants holes (44, 38, 40, 42) extending therethrough perpendicular to said membrane faces (26) and said collector faces (24) and disposed radially outward of said active channels (46, 48) for fluid communication between said cathode flow plates (20) and independent fluid communication between said anode flow plates (22), and

said cooling channels (74, 76, 78) of said cathode flow plates (20) extends transversely relative to said center axis (C) thereof and at a first direction beyond said active channels (46, 48) of said cathode flow plate (20) and said active channels (46, 48) of said anode flow plates (22) to overlap said transport channels branches (61, 62) and sub-branches (64) of said anode flow plates (22) and said cooling channels (74, 76, 78) of said anode flow plates (22) extending transversely relative to said center axis (C) thereof and at a second direction approximately ninety degrees from said first direction beyond said active channels (46, 48) of said anode flow plate (22) and said active channels (46, 48) of said cathode flow plate (20) to overlap said branches (61, 62) and sub-branches (64) of said cathode flow plates (20) for providing cooling axially between said cooling channels (74, 76, 78) of said anode flow plate (22) to said branches (61, 62) and sub-branches (64) of said cathode flow plate (20) and between said cooling channels (74, 76, 78) of said cathode flow plate (20) to said branches (61, 62) and sub-branches (64) of said anode flow plate (22).

4. A fuel cell stack as set forth in claim 1 wherein said center axis (C) of each of said anode flow plates (22) and cathode flow plates (20) are coaxial.

5. A fuel cell stack as set forth in claim 4 wherein each of said anode flow plates (22) is disposed one of one-hundred eighty degrees and zero degrees from each other about said center axis (C) and one of ninety degrees and two-hundred seventy degrees from each of said cathode flow plates (20) about said center axis (C).

6. A fuel cell stack as set forth in claim 1 wherein said reactant holes (44, 38, 40, 42) include an inlet hole (38) and an outlet hole (40) radially opposite said inlet hole (38) thereof and a first bypass hole (42) ninety degrees from said inlet hole (38) thereof about said center axis (C) thereof and a second bypass hole (44) radially opposite said first bypass hole (42) thereof.

7. A fuel cell stack as set forth in claim 6 wherein said inlet hole (38) of each of said anode flow plates (22) is aligned with one of said first bypass hole (42) and said second bypass hole (44) of each of said cathode flow plates (20) and said first bypass hole (42) of each of said anode flow plates (22) is aligned with one of said outlet hole (40) and inlet hole (38) of each of said cathode flow plates (20) and said outlet hole (40) of each of said anode flow plates (22) is aligned with one of said second bypass holes (44) and first bypass holes (42) of each of said cathode flow plates (20) and said second bypass hole (44) of each of said anode flow plates (22) is aligned with one of said inlet hole (38) and outlet hole (40) of each of said cathode flow plates (20).

8. A fuel cell stack as set forth in claim 7 wherein said inlet holes (38) of each of said cathode flow plates (20) are coaxial and said inlet holes (38) of each of said anode flow plates (22) are coaxial and ninety degrees from said inlet holes (38) of

said cathode flow plates (20) about said center axis (C) to align said inlet hole (38) of each of said anode flow plates (22) with said first bypass hole (42) of each of said cathode flow plates (20) and align said first bypass hole (42) of each of said anode flow plates (22) with said outlet hole (40) of each of said cathode flow plates (20) and align said outlet hole (40) of each of said anode flow plates (22) with said second bypass holes (44) of each of said cathode flow plates (20) and align said second bypass hole (44) of each of said anode flow plates (22) with said inlet hole (38) of each of said cathode flow plates (20) for parallel distribution of fluid to said flow plates (20, 22).

9. A fuel cell stack as set forth in claim 7 wherein said inlet holes (38) of each of said cathode flow plates (20) are coaxial with every other one of the other of said cathode flow plates (20) and said inlet holes (38) of each of said anode flow plates (22) being coaxial with every other one of the other of said flow plates (20, 22) for series of distribution of fluid to said active channels (46, 48) of said flow plates (20, 22).

10. A fuel cell stack as set forth in claim 6 wherein each of said flow plates (20, 22) defines a plurality of coolant holes (68, 70, 72, 66) extending therethrough perpendicular to said membrane face (26) and collector face (24) thereof and having coolant hole diameters (DC) being equal and said coolant holes (68, 70, 72, 66) including two inlet-side coolant holes (66) inward from and on either side of said inlet hole (38) and a pair of outlet-side coolant holes (68) inward from and on either side of said outlet hole (40) and two first bypass-side coolant holes (70) inward from and on either side of said first bypass hole (42) and two second bypass-side coolant holes (72) inward from and on either side of said second bypass hole (44) and each of said coolant holes (68, 70, 72, 66) of each of said cathode flow plates (20) in alignment with one of said coolant holes (68, 70, 72, 66) of each of said anode flow plates (22).

11. A fuel cell stack as set forth in claim 10 wherein said cooling channels (74, 76, 78) include a first bypass-side cooling channel (74) extending between said first bypass-side coolant holes (70) and said cooling channels (74, 76, 78) include a second bypass-side cooling channel (76) extending between said second bypass-side coolant holes (72) and parallel to said first bypass-side cooling channel (74) and said cooling channels (74, 76, 78) include a plurality of transverse cooling channels (78) extending perpendicular to and between said first bypass-side cooling channel (74) and said second bypass-side cooling channel (76).

12. A fuel cell stack as set forth in claim 6 wherein each of said flow plates (20, 22) defines a plurality of alignment holes (80) extending therethrough perpendicular to said collector face (24) and said membrane face (26) thereof and one of said alignment holes (80) being between said inlet hole (38) and said second bypass hole (44) and one other of said alignment holes (80) being between said second bypass hole (44) and said outlet hole (40) and one other of said alignment holes (80) being between said outlet hole (40) and said first bypass hole (42) and a one other of said alignment holes (80) being between said first bypass hole (42) and said inlet hole (38) and each of said alignment holes (80) of each of said cathode flow plates (20) is in alignment with one of said alignment holes (80) of each of said anode flow plates (22).

13. A fuel cell stack as set forth in claim 1 including a plurality of said cathode flow plates (20) and a plurality of said anode flow plates (22) wherein a plurality of membrane electrode assemblies (82) for collecting and conducting protons therethrough each present an anode face being clamped against said membrane face (26) of one of said anode flow

plates (22) and a cathode face opposite and parallel said anode face and being clamped against said membrane face (26) of one of said cathode flow plates (20).

14. A fuel cell stack as set forth in claim 1 including a plurality of said cathode flow plates (20) and a plurality of said anode flow plates (22) wherein a plurality of seals (84, 86, 88) each for conducting electricity and preventing migration of fluid therethrough include a cathode end seal (84) being disposed against said collector face (24) of one said cathode flow plates (20) and an anode end seal (86) being disposed against said collector face (24) of one of said anode flow plates (22) and a plurality of intermediate seals (88) each being disposed against said collector face (24) of one said cathode flow plates (20) and said collector face (24) of one said anode flow plates (22).

15. A fuel cell stack as set forth in claim 14 wherein a pair of collector plates (90) each abut one of said end seals (84, 86) and a pair of end plates (92) each abutting one of said collector plates (90).

16. A fuel cell stack as set forth in claim 1 wherein said three active channels (46, 48) include a middle active channel (46) and a pair of diverging active channels (48) disposed adjacent said middle active channel (46) and diverging in opposite directions from said middle active channel (46) and then parallel with said middle active channel (46) and converging into said outlet-side manifold (54) with said middle active channel (46).

17. A fuel cell stack as set forth in claim 16 wherein said membrane face (26) of each of said flow plates (20, 22) presents a plurality of ribs (56) each disposed between two adjacent of said channel sets (50) with each rib (56) defining an inlet head (58) and an outlet head (60) and each of said heads (58, 60) being bulbous and interconnected by a straight section.

18. A fuel cell stack as set forth in claim 1 wherein each of said branches (61, 62) extends from one of said one inlet hole (38) and said outlet hole (40) and is in fluid communication with two of said sub-branches (64) and each of said sub-branches (64) is in fluid communication with one of said manifolds (52, 54).

19. A fuel cell stack as set forth in claim 18 wherein each of said flow plates (20, 22) define a plurality of slots (65) each interconnecting adjacent of said sub-branches (64) and one of said slots (65) is adjacent each of said heads (58, 60).

20. A fuel cell stack as set forth in claim 1 wherein each of said flow plates (20, 22) have an inlet edge (28) and an outlet edge (30) parallel to said inlet edge (28) and interconnected by a first bypass edge (32) perpendicular to said inlet edge (28) and said outlet edge (30) and a second bypass edge (34) parallel to said first bypass edge (32) to define a square perimeter and each of said reactant holes having reactant hole diameter (DR) being equal and each being radially spaced inwardly from a different one of said edges (28, 30, 32, 34) by an equal distance and said inlet hole (38) is adjacent and inward from said inlet edge (28) and midway between said first bypass edge (32) and said second bypass edge (34) and said outlet hole (40) is inward from said outlet edge (30) and midway between said first bypass edge (32) and said second bypass edge (34) and said first bypass hole (42) is adjacent and inward from said first bypass edge (32) and midway between said inlet edge (28) and said outlet edge (30) and said second bypass hole (44) is adjacent and inward from said second bypass edge (34) and midway between said inlet edge (28) and said outlet edge (30).