

Old Dominion University

ODU Digital Commons

Civil & Environmental Engineering Theses &
Dissertations

Civil & Environmental Engineering

Winter 1991

Continuum Modeling Methodology for Dynamic Behavior of Towers

Khaled A. Obeid
Old Dominion University

Follow this and additional works at: https://digitalcommons.odu.edu/cee_etds



Part of the [Civil Engineering Commons](#)

Recommended Citation

Obeid, Khaled A.. "Continuum Modeling Methodology for Dynamic Behavior of Towers" (1991). Doctor of Philosophy (PhD), Dissertation, Civil & Environmental Engineering, Old Dominion University, DOI: 10.25777/8ash-3w33
https://digitalcommons.odu.edu/cee_etds/101

This Dissertation is brought to you for free and open access by the Civil & Environmental Engineering at ODU Digital Commons. It has been accepted for inclusion in Civil & Environmental Engineering Theses & Dissertations by an authorized administrator of ODU Digital Commons. For more information, please contact digitalcommons@odu.edu.

CONTINUUM MODELING METHODOLOGY
FOR DYNAMIC BEHAVIOR OF TOWERS

BY

Khaled A. Obeid
B.S.C.E. June 1971, Alexandria University, Egypt
M.S. May 1975, The University of Southwestern Louisiana

A Dissertation Submitted to the Faculty of the Civil
Engineering Department in Partial Fulfillment of
the Requirements for the Degree of

DOCTOR OF PHILOSOPHY

OLD DOMINION UNIVERSITY
December 1981

Approved by:

**CONTINUUM MODELING METHODOLOGY
FOR DYNAMIC BEHAVIOR OF TOWERS**

PHD. DISSERTATION

BY

Khaled A. Obeid, P.E.

CIVIL ENGINEERING DEPARTMENT

OLD DOMINION UNIVERSITY

ABSTRACT

A very common problem in Civil Engineering is the analysis and design of lattice structures. These types of structures generally consist of repetitive sections and have been utilized in the erection of transmission and communication towers, space roof trusses, solar energy collectors, and space platforms. Since lattice structures consist of a significantly large number of members and subsequently a large number of nodes, the classical discrete technique of analysis can be very expensive even on today's modern computers. This study applies a rational approach which capitalizes on the repetitive nature of towers to develop the equivalent continuum model for the lattice structure. The continuum approach is based on equivalencing the strain and kinetic energies of the actual latticed tower with that of the equivalent continuum model. Introducing the kinematic assumption that the strain components of the lattice structure have linear variations in the plane of the tower cross section is the key step in obtaining correct expressions for the equivalent properties of the continuum model. Procedures for developing continuum models are presented along with the constitutive equations and strain expressions. The procedures are demonstrated by applying the continuum modeling approach to planar trusses, triangular towers with constant cross sections, triangular towers with variable cross sections, and towers with rectangular cross sections. Numerical results for static deflections and free vibration analysis of planar trusses and towers with triangular cross sections are presented, and they indicate the high accuracy of the continuum model solution. In addition, a numerical technique is developed to obtain member forces of the actual lattice structure from the continuum model

results. Moreover, a comparison of computer times using the SAP IV finite element program to analyze the actual lattice structures versus the equivalent continuum model is presented. In general, the continuum approach when applied to the analysis of lattice structures demonstrates a significant savings in computer cost with a relatively insignificant loss in accuracy.

ACKNOWLEDGEMENTS

The author wishes to express his gratitude to all the members of his Dissertation Advisory Committee for their support and encouragement throughout the course of this study.

He is especially grateful to his advisor, Dr. Dennis J. Fallon, and his former advisor, Dr. Kenneth H. Murray for their guidance, encouragement and constructive suggestions throughout this study. The author also wishes to extend his appreciation to Dr. Ahmed K. Noor for his help and invaluable suggestions in this research. Deepest appreciation and special thanks are given to Drs. Earl A. Thornton, Richard H. Bigelow, and William A. Drewry, the Chairman of the Civil Engineering Department, for their helpful suggestions and encouragement during this study.

The author would like to extend his thanks to Glenn-Rollins and Associates Consulting Engineers for their invaluable help and assistance in the preparation and typing of this dissertation.

Last but not least, the author would like to extend his appreciation along with special thanks to his family for their patience and encouragement during the course of his graduate studies.

TABLE OF CONTENTS

| | PAGE |
|--|------|
| LIST OF TABLES | |
| LIST OF FIGURES | |
| LIST OF SYMBOLS | |
| Chapter | |
| I. INTRODUCTION | |
| 1.1 General Remarks | 1 |
| 1.2 Literature Review | 3 |
| 1.3 Objectives and Scope | 6 |
| II. ANALYTICAL DEVELOPMENT OF CONTINUUM MODELS | |
| 2.1 The Equivalent Continuum Model | 8 |
| 2.2 Development of the Stiffness and Inertia Coefficients of the Equivalent Continuum Model | 10 |
| 2.3 Use of MACSYMA Computarized Symbolic Manipulation in Developing the Continuum Properties | 13 |
| 2.4 Convergence of the Equivalent Continuum Model Solution | 14 |
| III. APPLICATION OF THE CONTINUUM MODEL TO PLANAR TRUSSES | |
| 3.1 General Remarks | 17 |
| 3.2 Kinematic Hypothesis and Displacement Relationship | 17 |
| 3.3 Strain Energy of the Continuum Model | 20 |
| 3.4 Kinetic Energy of the Equivalent Continuum Model | 25 |
| 3.5 Work Done by External Forces | 28 |
| 3.6 Evaluation of Member Forces From Continuum Model Solution of Planar Truss | 28 |
| 3.7 Numerical Studies of Planar Truss | 31 |

| | | |
|-----|--|-----|
| IV. | APPLICATION TO TOWERS WITH TRIANGULAR CROSS SECTIONS | |
| 4.1 | General Remarks | 46 |
| 4.2 | Characteristics of Free Standing Towers with Triangular Cross Sections | 47 |
| 4.3 | Kinematic Assumptions and Displacement Relationships | 53 |
| 4.4 | Strain Energy and Stiffness Coefficients of Equivalent Continuum Model | 59 |
| 4.5 | Kinetic Energy and Mass Coefficients of Equivalent Continuum Model | 65 |
| 4.6 | Work Done by External Forces on Three Dimensional Towers | 66 |
| 4.7 | Evaluation of Member Forces From Continuum Model Solution of Three Dimensional Towers ... | 69 |
| 4.8 | Numerical Studies of Triangular Towers | 70 |
| V. | APPLICATIONS TO TOWERS WITH RECTANGULAR CROSS SECTIONS | |
| 5.1 | General Remarks | 82 |
| 5.2 | Kinematic Assumptions | 82 |
| 5.3 | Strain Energy and Stiffness Coefficients of the Equivalent Continuum Model | 89 |
| 5.4 | Kinetic Energy and Mass Coefficients of the Equivalent Continuum Model | 90 |
| 5.5 | General Discussions and Findings | 92 |
| VI. | CONCLUSIONS AND RECOMMENDATIONS | |
| 6.1 | Summary | 95 |
| 6.2 | Conclusions | 96 |
| 6.3 | Recommendation for Future Studies | 98 |
| | REFERENCES | 99 |
| | APPENDICES | |
| | APPENDIX A. Strain and Kinetic Energies of Planar Trusses | 101 |

APPENDIX B. Strain Energy and Kinetic Energy
of Three Dimensional Towers106

APPENDIX C. Listing of MACSYMA Program for the
Analysis of Towers with Variable
Triangular Cross Sections109

AUTOBIOGRAPHICAL STATEMENT

LIST OF TABLES

| TABLE | PAGE |
|---|------|
| 3.1 Continuum Stiffness Coefficients for Planar Truss Considered | 23 |
| 3.2 Engineering Equivalent Stiffness Coefficients for Planar Truss Considered | 26 |
| 3.3 Equivalent Mass Coefficients for Planar Truss Considered | 29 |
| 3.4 Accuracy of Displacements Obtained by the Equivalent Beam Model for Planar Truss Considered Due to Unit Axial Loading | 36 |
| 3.5 Accuracy of Displacements Obtained by the Equivalent Beam Model for Planar Truss Considered Due to Unit Shear Loading | 37 |
| 3.6 Accuracy of Displacements Obtained by the Equivalent Beam Model for Planar Truss Considered Due to Unit Bending Moment Loading | 39 |
| 3.7 Natural Frequencies and Computer Time Comparison Between Finite Element and Equivalent Beam Model of Planar Truss Considered | 41 |
| 4.1 Equivalent Stiffness Coefficients for the Triangular Tower with Constant Cross Sections | 61 |
| 4.2 Equivalent Stiffness Coefficients for the Triangular Tower with Variable Cross Section | 64 |
| 4.3 Equivalent Mass Coefficients for the Triangular Tower with Constant Cross Section | 67 |
| 4.4 Equivalent Mass Coefficients for the Triangular Tower with Variable Cross Sections | 68 |
| 4.5 Axial Displacements and CPU Time Comparison of the Tower Shown in Figure 4.1 Due to Pure Axial Loading | 72 |
| 4.6 Natural Frequencies of Vibrations and CPU Time Comparison of the Tower Shown in Figure 4.1 | 75 |

| | | |
|-----|--|----|
| 4.7 | Natural Frequencies of Vibrations and CPU Time for the Tower Shown in Figure 4.2 | 79 |
| 5.1 | Equivalent Stiffness Coefficients for the Continuum Model of the Rectangular Tower Shown in Figure 5.1 | 91 |
| 5.2 | Equivalent Mass Coefficients for the Continuum Model of the Rectangular Tower Shown in Figure 5.1 | 93 |

LIST OF FIGURES

| FIGURE | PAGE |
|--|------|
| 1.1 Most Common Repetitive Structures | 2 |
| 2.1 Flow Chart for MACSYMA Program Used in the Analysis of Latticed Towers..... | 15 |
| 3.1 Planar Truss and Associated Properties | 18 |
| 3.2 Systems of Static Loadings Considered in the Present Study | 32 |
| 3.3 Continuum Model Static Loadings and Sign Convention | 33 |
| 3.4 Free Vibration Mode Shapes of Five-bay Cantilevered Planar Truss | 42 |
| 3.5 Bar Graph Displaying Comparative of Low Frequencies Obtained by the Equivalent Beam Model for the Planar Truss | 43 |
| 4.1 Five-bays Double Laced Tower with Constant Triangular Cross Section | 48 |
| 4.2 Five-bay Double Laced Tower with Variable Triangular Cross Sections | 49 |
| 4.3 Repeating Element of Double Laced Triangular Tower with Constant Cross Section and Associated Members Properties | 50 |
| 4.4 Repeating Element of Double Laced Triangular Tower with Variable Cross Sections and Associated Members Properties | 51 |
| 4.5 Continuum Beam Model Sign Convention | 55 |
| 4.6 Static Loading Systems Used in the Analysis of Towers Considered | 72 |
| 4.7 Bar Graph Displaying Comparative Accuracy of Low Vibration Frequencies Obtained by the Equivalent Continuum for Cantilevered Triangular Tower with Constant Cross Section | 76 |
| 4.8 Vibration Mode Shapes for the Cantilevered Triangular Tower with Constant Cross Section | 78 |

| | | |
|-----|--|-----|
| 4.9 | Bar Graph Displaying Comparative Accuracy of Low Vibration Frequencies Obtained by the Equivalent Continuum Model for the Cantilevered Tower with Variable Triangular Cross Sections | 80 |
| 5.1 | Five-bay Double Laced Tower with Constant Rectangular Cross Section | 83 |
| 5.2 | Repeating Element of Double Laced Rectangular Tower with Constant Cross Section | 85 |
| 5.3 | Equivalent Continuum Sign Convention for the Tower Shown in Figure 5.1 | 86 |
| C.1 | Repeating Element of Tower with Variable Triangular Cross Section Used in MACSYMA Program | 110 |
| C.2 | Flow Chart of Fortran IV Program Used in the Present Study to Evaluate the Equivalent Continuum Properties of Different Latticed Structures | 118 |

LIST OF SYMBOLS

| | |
|-------------------------|--|
| A_1 | - cross sectional area of longitudinal members |
| A_b | - cross sectional area of batten members |
| A_d | - cross sectional area of diagonal members |
| A_{EQ} | - cross sectional area of equivalent continuum model |
| A_{sh} | - equivalent shear area of the continuum model |
| B | - length of batten members in the three dimensional towers |
| $B(i)$ | - i^{th} bending vibration mode |
| C_{ij} | - stiffness coefficients of the equivalent continuum |
| \bar{C}_{ii} | - equivalent stiffness coefficients of reduced theory |
| D | - length of diagonal members in planar truss and three dimensional towers |
| $\{d\}$ | - displacement vector of equivalent continuum model |
| $\{\dot{d}\}$ | - velocity vector of equivalent continuum |
| E | - modulus of elasticity of equivalent continuum model |
| $E_{(ij)}$ | - modulus of elasticity of lattice members |
| $E_{(i)}$ | - i^{th} extensional vibration mode |
| $\{e\}$ | - vector of continuum strain measures |
| $e_x, 2e_{xy}, 2e_{xz}$ | - extensional and shearing strains of lattice members of the repeating element |
| e_x^o, e_y^o, e_z^o | - extensional strains of the equivalent continuum |
| F_{ij} | - force in member (ij) of the repeating element |

| | |
|--------------------|--|
| σ_{ij} | - stress in member (ij) of the repeating element |
| G | - shear modulus |
| H | - height of triangular cross sectional towers |
| h | - height of planar truss |
| I_1, I_b, I_d | - moments of inertia of repeating element members |
| I_{EQ} | - moment of inertia of the equivalent continuum |
| J | - torsional rigidity of the equivalent continuum model |
| k | - beam member stiffness matrix |
| L | - length of repeating element of latticed structure |
| \bar{L} | - length of repeating element of the equivalent continuum |
| L_{ij} | - length of member (ij) of the repeating element |
| ΔL_{ij} | - change in length of member (ij) of the repeating element |
| $l_{ij}^{(k)}$ | - direction cosines of the k^{th} member of the repeating element |
| [M] | - consistent mass matrix of the equivalent beam model |
| m_{ij} | - equivalent mass coefficients of the continuum model |
| \bar{m}_{ij} | - equivalent mass coefficients of reduced theory |
| M, M_x, M_y, M_z | - applied moment loadings for planar truss and towers considered |
| N, N_x, N_y | - applied axial loading |
| NR | - total number of repeating elements in expression (2.6) |
| n | - total number of members in repeating element |

| | |
|-----------------------------------|---|
| P_x, P_y, P_z | - nodal external forces |
| p_i | - external load component in the coordinate directions at the i^{th} node |
| ρ_l | - mass density per unit length of longitudinal members of the repeating element |
| ρ_b | - mass density per unit length of batten members of the repeating element |
| ρ_d | - mass density per unit length of diagonal members of the repeating element |
| Q, Q_x, Q_y, Q_z | - applied shear loadings |
| T | - kinetic energy of the equivalent continuum |
| T' | - applied torsional loading |
| $T(i)$ | - i^{th} torsional vibration mode |
| U | - strain energy of the equivalent continuum |
| u^0, v^0, w^0 | - displacement components of the equivalent continuum |
| W | - work done by external forces |
| W_{nc} | - work done by nonconservative forces acting on the system |
| V | - total potential energy of the system |
| u, v, w | - displacement components of lattice members of the repeating element |
| $\bar{u}, \bar{v}, \bar{w}$ | - displacement parameters for warping and distortion of rectangular cross section |
| X, Y, Z | - cartesian coordinate system |
| s, y, z | - member coordinate directions of repeating element |
| \bar{z} | - vertical distance between the centerline of the repeating section and the node considered |
| $K_x^{(k)}, K_z^{(k)}, K_t^{(k)}$ | - bending strains and twist of lattice member of the repeating element |

| | |
|--------------------------------|--|
| K_t^o, K_z^o, K_t^o | - curvature changes and twist of the equivalent continuum |
| \bar{K}, θ^o | - strain parameters for warping of rectangular cross section |
| $\theta_x, \theta_y, \theta_z$ | - rotational components about the cartesian coordinates |
| γ_{xy}^o | - shearing strain of the equivalent continuum model |
| $\Delta\%$ | - percentage difference between the equivalent continuum and the actual structure |
| δ | - variation taken during indicated time interval |
| ω | - natural circular frequency of vibration |
| ω_{EQ} | - natural frequency of vibration obtained by the equivalent continuum model |
| ω_{ACT} | - natural frequency of vibration obtained by finite element analysis of the actual structure |
| β | - angle of sloping tower legs |
| λ, Q_1 | - quantities specified in Table 4.1 and Table 5.1 |
| ν | - Poisson's ratio |
| $[\zeta]$ | - transformation matrix specified in expression (B.4) |

CHAPTER I

INTRODUCTION

1.1 General Remarks

One of the most common types of civil engineering structures used today is the latticed structure. This popularity stems from the relatively large strength to weight ratio possessed by these structures and their relative ease of fabrication and erection as compared with other structures (1). Indeed, significant interest has been generated by the potential use of these structures in space as solar energy collectors, as transmission or communication towers, and as large span roof structures as shown in Figure (1.1).

A latticed structural system is a network of elements which exhibit three dimensional load carrying capabilities. The characteristics which make the analysis and design of latticed structures a special class are the three dimensional analytical solution required for a complete description of the structural behavior and the relatively large number of individual structural members in the structure. These two characteristics make the attainment of an analytical solution by the use of direct methods (finite element, finite differences) computationally very expensive. This is due in part to the large number of algebraic equations generated by the above techniques. Consequently, approximate methods of analysis are receiving a significant amount of attention in an effort to reduce this computational expense while achieving results which accurately predict the response of the lattice structure.

Another important characteristic of most lattice structures which permits reducing their dimensionality is that the individual members are often connected together to form repetitive sections. Capitalizing on

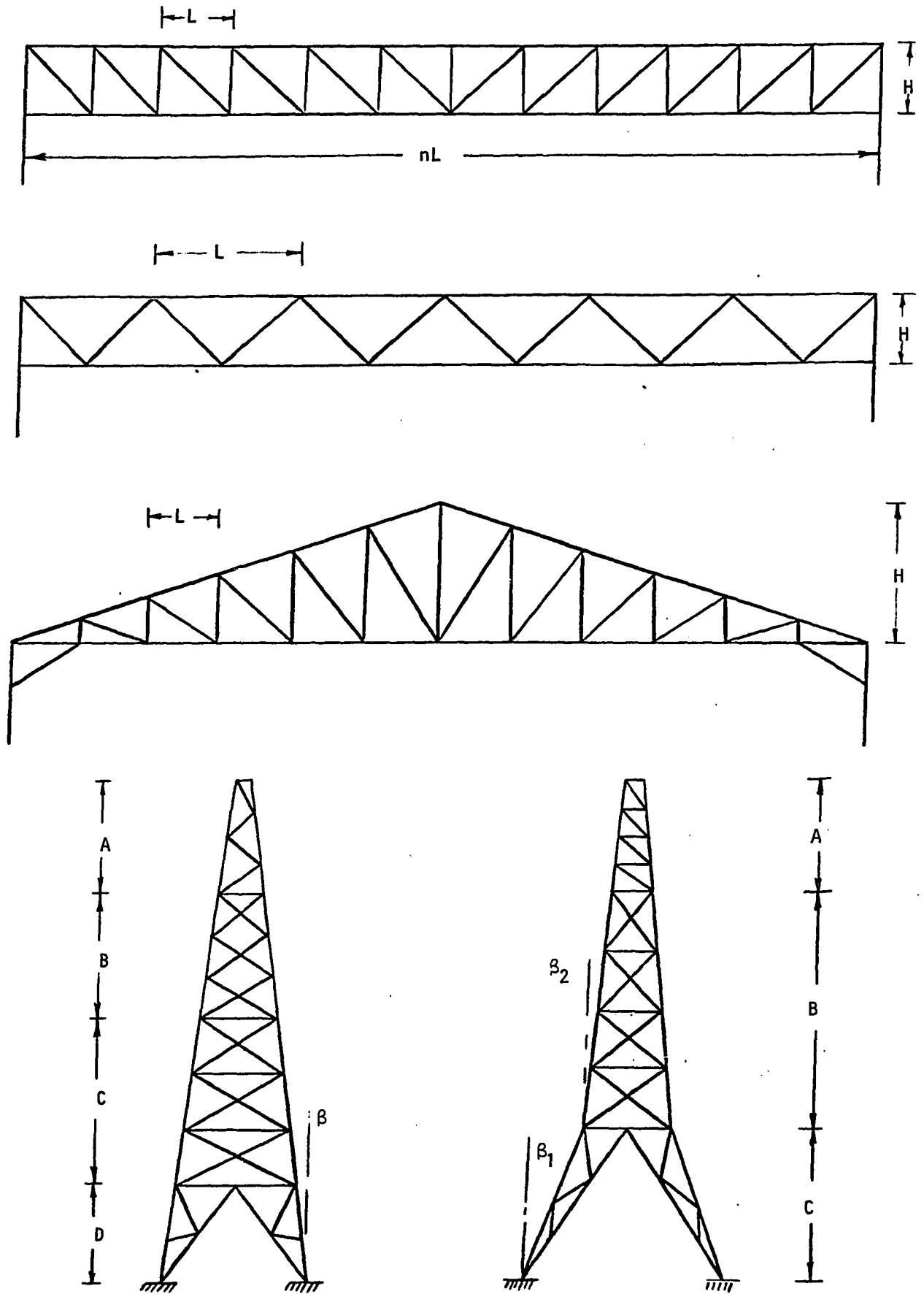

FIGURE 1.1 - MOST COMMON REPETITIVE STRUCTURES (26).

this characteristic, one can model the three dimensional repeating section of the structure into a one dimensional equivalent element having the equivalent properties of the repeating section (7). The equivalent element will approximate the actual response to the latticed structure and will reduce the total number of degrees of freedom in the problem, thereby, producing a reduction in the computational cost. A major question that remains is how good an approximation is the equivalent model solution? Herein lies the overall objective of the present study which investigates this approximation as it applies to civil engineering structures under static loadings as well as free vibration analysis.

1.2 Literature Review

The most common procedures used for analyzing lattice structures can be grouped into three techniques: Direct Methods, Discrete Field Analysis, and the Equivalent Continuum Method.

Direct Methods as previously mentioned require the solution of a system of algebraic equations. Equilibrium or compatibility equations are written at each node. These equations are then solved to obtain either the joint displacement (classically referred to as the stiffness method) or the forces (classically referred to as the flexibility method). These methods are "exact" (2) in the sense that no simplifying assumptions are made to the structural element and the mathematical model utilized involves only the usual assumptions associated with linear elastic structural behavior. Both force and displacement methods can be highly automated for implementation on digital computers. Even with the use of efficient numerical computing schemes (substructuring and sparse matrix techniques), analyzing a large structural system using direct methods requires a very large number of simultaneous

equations which may overtax present-day computers (3). In addition, if the designer is interested in obtaining a dynamic analysis, the computation of the natural frequencies and mode shapes via an eigenvalue solution can be very expensive.

Discrete field methods are the most commonly used techniques for analyzing repetitive lattice structures without involving large numbers of algebraic equations. A summary of the state-of-the-art of discrete field analysis of lattice structures is given by both Dean (4) and Avent (5). The discrete field method is divided into two separate approaches: the micro and macro techniques.

The micro method exploits the repetitive nature of the lattice structure because the mathematical model is derived by analyzing the basic lattice element and relating its behavior to that of the adjoining and connecting elements. Consequently, the force and deformation characteristics of a small segment of the actual lattice are described in terms of the field coordinates using finite difference operators. The finite difference equations can be solved directly or can be converted into approximate differential equations by replacing the finite difference operators with the appropriate Taylor series expansion as employed by Renton (6) and Dean (7). However, the solution of the mathematical model can be written in several forms. One such form is a set of arbitrary functions whose arguments have a specified dependence on the field coordinates. Another form of solution is a single trigonometric series of functions of one coordinate with functions of the other coordinates as coefficients. Another alternative approach is to express the solution as multiple series of functions of the coordinate having constant coefficients.

The macro approach extracts a closed form solution for the entire lattice structural system without depending on discretizing the structure. This approach is characterized by the generation of a mathematical model in the form of a summation equation. The component members, whose span dimensions correspond to those of the whole system as opposed to basic elements as in the micro approach, are analyzed separately for their behavior at the lattice nodes. These components are superimposed and compatibility is enforced at the end nodes. The solution of the resulting equations is determined using the orthogonality properties of the series functions found in the member analyses. This technique is particularly well adapted for cases in which lattice structures are interacting with continuous elements. The micro approach is more appropriate for analyzing repetitive lattice structures by the discrete field method. Therefore, Dean (7) applied the micro approach and obtained closed form solutions for the transverse displacements of simple planar truss configurations. Renton (6) took the analysis one step further by deriving an approximate differential equation which includes a shear deformation effect for some trusses.

Equivalent continuum methods of repetitive lattice structures have the major advantage of providing a practical approach for the analyst to obtain the solution of the system's global response without using a large number of equations. Therefore, the designer can utilize this technique to indicate the structural response of a latticed structure in parametric studies with regards to the structural geometry or material properties with minimum computer expense. The most common approaches for developing continuum models are the intuitive approach and the energy equivalence approach. In the intuitive approach, a

portion of the equivalent continuum is first equivalenced with a portion of the actual lattice. The continuum stiffness can then be obtained by introducing a unit strain state (7) and taking the stress resultants to be the equivalent stiffnesses. Timoshenko (8) applied the intuitive approach to the static analysis of single-layer grids. Heki and Saka (9) introduced tensor transformations to obtain equivalent stiffness for more general grid configurations. The equivalent continuum approach has been applied by Sun and Yang (10) in analyzing single-layer grids with in-plane deformation, free vibration, and wave propagation. The procedure presented by Noor, Anderson, and Greene (11) is based on obtaining the strain and the kinetic energies of the repeating element in terms of the continuum strain and displacement parameters. From these energies, the constitutive relations, governing differential equations, and boundary conditions are obtained using a variational principle. Nayfeh (13) also used the equivalent continuum approach.

In the majority of the studies documented in the literature, the focus has been on static analysis. There is a paucity of studies dealing with free vibration analysis. In addition, the equivalent continuum approach has not been applied to some important and common design problems in civil engineering such as communication and transmission towers. In addition, to the author's knowledge, methods for the resolution of the forces obtained from the continuum model back into member forces of the actual structure for design has not been reported in the literature.

1.3 Objectives and Scope

The present dissertation attempts to bridge the above gaps by applying a simple, rational energy equivalence approach to analyze

pin-jointed towers with constant cross sections and towers with variable triangular cross sections. The dissertation presents a technique to recover member forces of the actual structure using results obtained from the equivalent continuum model. Therefore, the objectives of the present study are to:

1. Apply a rational approach for developing continuum models for planar trusses, triangular towers with constant cross sections, and towers with variable triangular cross sections.
2. Show the reliability and the numerical accuracy of the continuum models developed by comparing continuum model results with those obtained from finite element models using SAP IV Program (12).
3. Develop a technique to allow the designer to calculate member forces of the actual structure from the results obtained by the continuum model analysis.

The scope of the present study includes the following:

1. Static and free vibration analysis for planar trusses using the equivalent continuum approach.
2. Static and free vibration analysis for towers with variable triangular cross sections.
3. Static and free vibration analysis for towers with constant triangular cross sections.

CHAPTER 11

ANALYTICAL DEVELOPMENT OF CONTINUUM MODELS

2.1 The Equivalent Continuum Model

In the formulation of an equivalent continuum model as a substitute for the actual lattice structure, the first step is the selection of the repeating element. A repeating element is defined as a collection of all the members which form the smallest possible repetitive pattern. In addition, these elements can be interchanged without affecting the original geometry of the lattice structure.

As previously mentioned in Chapter 1, an equivalent continuum model is defined as a mathematical model which possesses the equivalent strain energy and kinetic energy as the actual lattice structure when both models are identically deformed. This definition establishes the second step in the development of the equivalent continuum model. The strain energy and the kinetic energy of the repeating element are expressed as functions of the nodal displacements, joint rotations, and nodal velocities as well as the geometric and material properties of the individual members. These energies are summed for all the members of the repeating element to obtain the equivalent properties of the continuum model. Then, the boundary conditions of the actual lattice structure are simulated in the continuum model by setting the appropriate displacement parameters or force expressions to their prescribed values as given by Noor and Anderson (11).

The equivalent continuum model of a lattice structure is characterized by its strain energy and kinetic energy. The procedures indicated in (11) for developing the strain and kinetic energy expressions of the equivalent

continuum model are summarized as follows:

1. The typical repeating element is isolated from the lattice structure.
2. The strain energy and the kinetic energy expressions of the repeating element are obtained by summing the contributions of all members of the repeating element. This leads to energy expressions in terms of nodal displacement components and their associated velocities.
3. The appropriate kinematic hypothesis to express the nodal displacement components is introduced in terms of a selected set of displacement components for the equivalent continuum model. For example, in the present study, the displacement components along pin connected members of the repeating element are assumed to have a linear variation. In addition, the three displacement components of the lattice structure are assumed to have a linear variation in the plane of the cross section which results in the strain parameters being functions of the axial displacement only.
4. The relationships from step 3 are then substituted into the energy expressions which produce the stiffness and the inertia properties of the equivalent continuum model.

The transition from the discrete lattice structure to the continuum model is accomplished by expanding the strain components in the coordinate directions in a Taylor series about the centroid of the repeating element. The number of terms retained in the Taylor series expansion is dependent upon the complexity of the repeating element

and should not exceed the total number of degrees of freedom of the repeating element. In addition, compatibility at the interface between any two adjacent repeating elements must be insured so that the number of continuum strain parameters required in the equivalent continuum model can be reduced. Furthermore, the continuum model can still be simplified by neglecting the forces associated with some secondary strain parameters. This results in a set of algebraic equations which can be solved in terms of the reduced strain parameters of the equivalent continuum model. Numerical studies (11) have indicated that some of the derivatives of the displacement parameters of the equivalent continuum can be neglected in the kinetic energy expression without affecting the accuracy of the lower vibration frequencies. This is of particular importance in the design of typical civil engineering structures where the designer is generally concerned with the first few lower vibration frequencies.

2.2 Development of the Stiffness and Inertia Coefficients of the Equivalent Continuum Model

The constitutive relationships and the governing differential equations for the equivalent continuum model can be developed from the strain energy and the kinetic energy expressions obtained for the repeating element. The strain energy density function can be expressed as a quadratic function of the continuum model's strain components. The mathematical expression for this function is written in the following form:

$$U = 1/2 \{e\}^t [C] \{e\} \quad (2.1)$$

where U is the strain energy per unit length of the equivalent continuum model;

$\{e\}$ is the strain vector of the equivalent continuum; and

$[C]$ is the matrix of the continuum stiffness coefficients.

The stiffness coefficients in Equation (2.1) are obtained by differentiating the strain energy expressions with respect to the strain parameters. Specifically, the continuum stiffness coefficients can be expressed as follows:

$$C_{ij} = \frac{\partial^2 U}{\partial e_i \partial e_j} \quad (2.2)$$

The kinetic energy is a quadratic function of the continuum velocity parameters. The expression for the kinetic energy density function can be expressed as follows:

$$T = 1/2 \{\dot{d}\}^t [m] \{\dot{d}\} \quad (2.3)$$

Where T is the kinetic energy density function per unit length of the equivalent continuum model;

$\{\dot{d}\}$ is the vector of velocity parameters;

$[m]$ is the equivalent mass matrix coefficients of the equivalent continuum model; and

t denotes transposition.

The equivalent mass coefficients in Equation (2.3) can be obtained from the appropriate differentiation of the kinetic energy with respect to the velocity parameters as follows:

$$m_{ij} = \frac{\partial^2 T}{\partial \dot{d}_i \partial \dot{d}_j} \quad (2.4)$$

The governing differential equations of the equivalent continuum model are derived in a classical manner by applying Hamilton's principle (16) which can be expressed as follows:

$$\int_{t_1}^{t_2} \delta (T - V) dt + \int_{t_1}^{t_2} \delta W_{nc} dt = 0 \quad (2.5)$$

where $V \equiv$ total potential energy of the system, including both strain energy and potential energy of any conservative external forces,

$W_{nc} \equiv$ work done by non-conservative forces acting on the system, including damping and any arbitrary external loads, and

$\delta \equiv$ variation taken during indicated time interval.

The dependent variables in these differential equations are the generalized displacements of the continuum. For free vibration analysis, the time derivatives in the governing differential equations are eliminated by assuming that the generalized displacements have sinusoidal variations in time. Therefore, closed form solutions can be obtained for the continuum models with simple configurations and boundary conditions, since the governing equations are ordinary differential equations. However, for more complicated configurations or boundary conditions, approximate solutions such as the finite element technique or other Rayleigh - Ritz techniques are practical methods to solve the continuum model. The finite element method has been selected in this study to solve the equivalent continuum models.

2.3 Use of MACSYMA Computerized Symbolic Manipulation in Developing the Continuum Properties

MACSYMA is an interactive computer programming language developed by the Math Lab Group at Massachusetts Institute of Technology. The MACSYMA system has numerous capabilities for symbolic algebraic and calculus computations which eliminate the tedium of algebraic manipulation. The MACSYMA capabilities can be summarized as:

- a. Algebraic operations; MACSYMA has the ability to combine algebraic expressions through mathematical operations of addition, multiplication, and exponentiation.
- b. Calculus operations; MACSYMA has many built-in knowledge of the forms of derivatives of most the commonly used functions. In addition, MACSYMA has the capability of solving systems of differential equations using Laplace Transforms.
- c. Simplification of algebraic expressions; MACSYMA can do automatic simplification using greatest common divisors, replacing of logarithmic and trigonometric functions with their known values, factoring and combining terms over a common denominator, ordering terms according to power of particular variables, etc.
- d. Manipulation of subscripted variables; MACSYMA can handle subscripted functions and matrices which encompass matrix addition, multiplication and inversion.
- e. Display of output; MACSYMA displays the numerical and symbolic expression in two-dimensional format.

- f. Graphical output; MACSYMA also provides graphical output with character-plotting routines for use with terminals without line generating capabilities.
- g. Special commands and packages; MACSYMA has built-in capability for the solution of algebraic equations, Taylor series expansion, manipulation of trigonometric functions, evaluation of both definite and indefinite integrals in analytic form, and performing vector and tensor analysis.

In summary, the potential of the MACSYMA computerized symbolic manipulations is illustrated through different problems covering wide range of the structural mechanics areas. Applications (15), include generation of characteristic arrays of finite elements, evaluation of effective stiffness and mass coefficients of continuum models for lattice structures, and application of the Rayleigh-Ritz technique to the free vibration analysis of laminated composite elliptic plates.

The MACSYMA flow chart for the program developed by Noor and Anderson (15) is shown in Figure 2.1. This program has been modified and debugged during the course of the present study in order to analyze triangular towers with variable cross sections. The listing of the MACSYMA program used in this study is presented in Appendix C.

2.4 Convergence of the Equivalent Continuum Solution

It is intuitively expected that as the number of repeating elements in the lattice structure becomes large, the behavior of the continuum model approaches that of the actual lattice. Discussion of convergence for a simple one-dimensional problem is considered. As

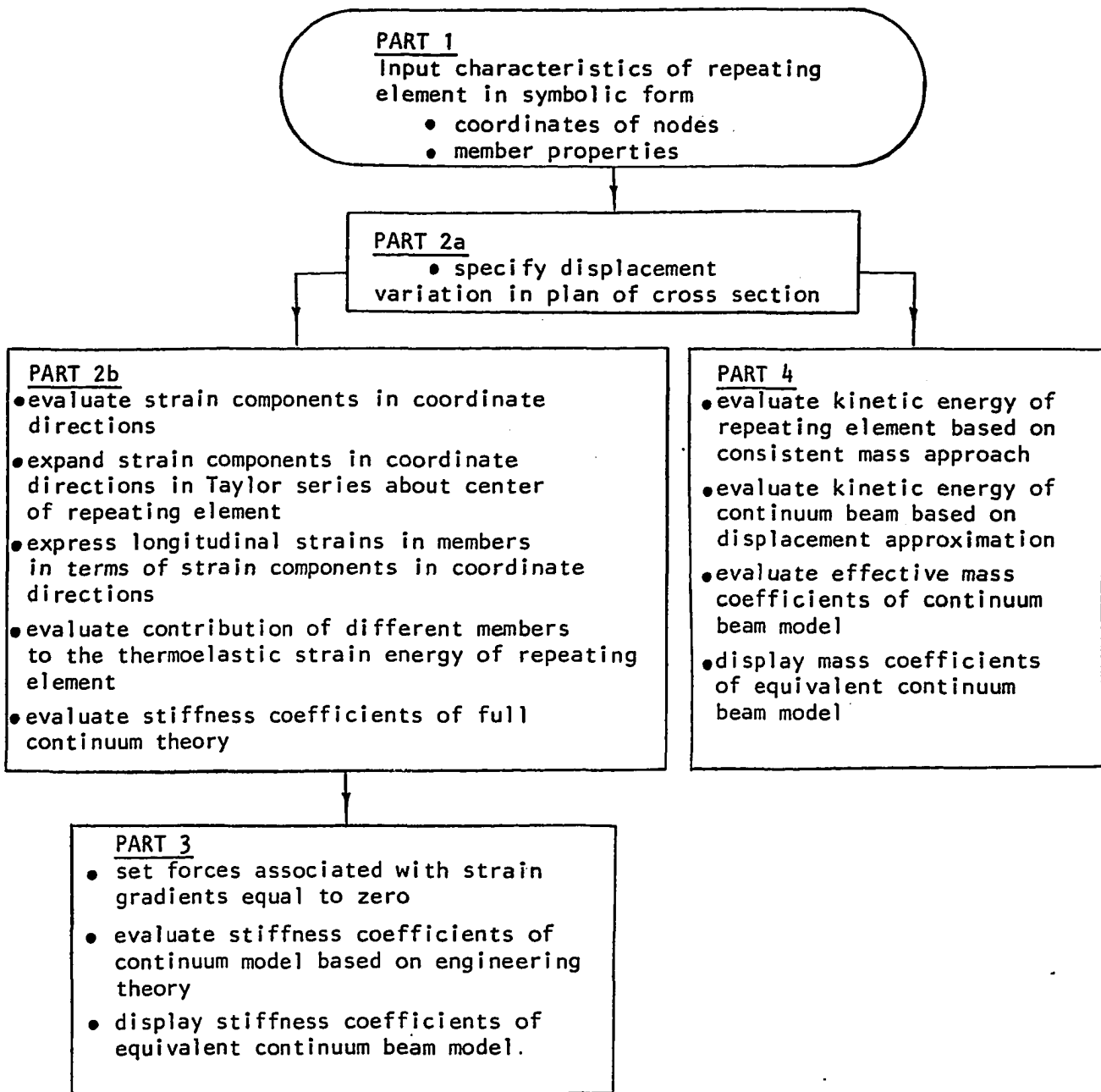

FIGURE 2.1 FLOW CHART FOR MACSYMA PROGRAM USED IN THE PRESENT ANALYSIS OF LATTICED TOWERS, (15)

previously mentioned, the stiffness and the mass coefficients must represent the behavior of the repeating element exactly. Therefore, the displacement expressions must simultaneously allow local free deformation to occur and satisfy compatibility between the interconnected repeating elements. The total strain energy for the structure can then be written as a summation over all repeating elements in the lattice structure as follows:

$$U = \sum_{i=1}^{NR} (1/2 \{e_i\}^t [C_i] \{e_i\}) \frac{L}{NR} \quad (2.6)$$

where NR is the total number of repeating elements;

$\{e\}$ is the strain vector;

$[C]$ is the matrix of the stiffness coefficients for the equivalent continuum; and

L is the total length of the lattice structure.

As NR becomes large, the term $\frac{L}{NR}$ approaches dx, and the vector $\{e_i\}$ becomes a continuous function $\{e(x)\}$. Therefore, the summation over the total number of repeating elements can then be replaced by the following integral:

$$U = \int_L \{e(x)\}^t [C] \{e(x)\} dx \quad (2.7)$$

Hence, the strain energy of the continuum model converges to that of the actual lattice structure as the number of repeating elements increases.

CHAPTER III
APPLICATION OF THE CONTINUUM MODEL
TO PLANAR TRUSSES

3.1 General Remarks

The objective of this chapter is to demonstrate the application of the continuum modeling methodology to the static and dynamic analysis of planar trusses.

Although the technique presented is very general, specific emphasis is placed on developing a continuum model for the planar truss illustrated in Figure 3.1. This figure shows a five-bay planar truss with a total number of twelve joints and twenty-one members. A typical repeating section (as defined in the previous chapter) is also illustrated in the same figure along with the sign convention used in the analysis. For simplicity, the material and section properties are assumed to be constant.

3.2 Kinematic Hypothesis and Displacement Relationship..

The first step in properly representing a two dimensional lattice as a one dimensional beam model is to establish the kinematic hypothesis. Since the deformed cross-section of any planar truss can be described by four displacement parameters (two translations at each of the top and bottom joints), the displacements in the plane of the cross section of the equivalent beam model can be assumed as follows:

$$u = u^0 + y \theta^0 \quad (3.1)$$

$$v = v^0 + y e_y^0 \quad (3.2)$$

where u^0 and v^0 are the displacements at $x = 0$ and $y = 0$ respectively, θ^0 is the rotation of the equivalent beam cross section; and

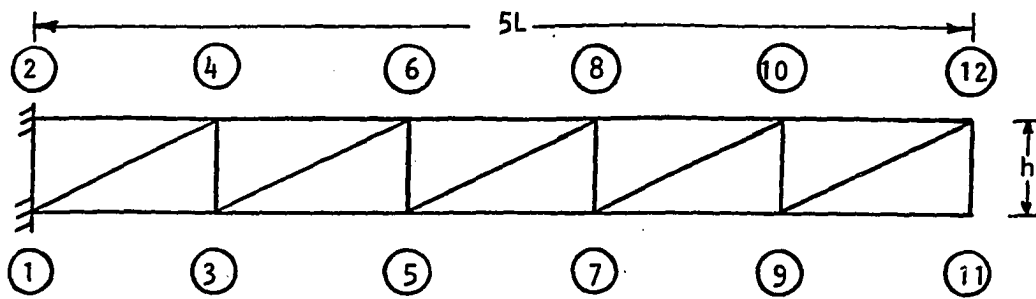

PLANAR TRUSS CONSIDERED

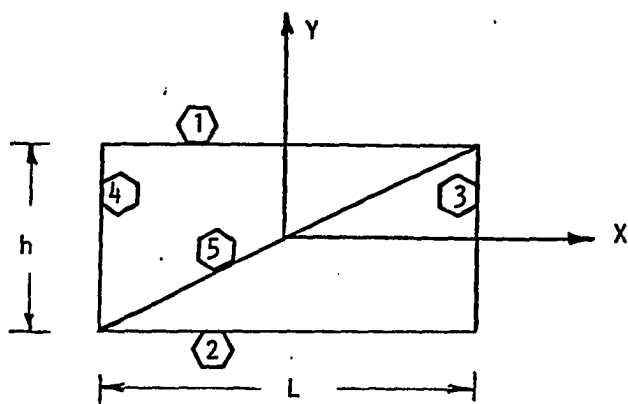

- $A_1 = A_v = A_d = 11.5 \text{ in}^2$
- $I_1 = I_v = I_d = 210.0 \text{ in}^4$
- $L = 120.0 \text{ in}$
- $h = 48.0 \text{ in}$
- $D = 129.24 \text{ in}$
- $E = 29000000.0 \text{ psi}$
- $\rho_1 = \rho_d = \rho_v = 0.283 \text{ lb/in}^3$

REPEATING ELEMENT

| MEMBERS | CROSS SEC. AREA | LENGTH | MOMENT OF INERTIA | MASS DENSITY |
|------------|-----------------|--------|-------------------|--------------|
| HORIZONTAL | A_1 | L | I_1 | ρ_1 |
| VERTICAL | A_v | h | I_v | ρ_v |
| DIAGONAL | A_d | D | I_d | ρ_d |

FIGURE 3.1 - PLANAR TRUSS AND ASSOCIATED PROPERTIES

e_y^0 is the extensional strain of the equivalent beam cross section in the y direction.

All four parameters u^0 , v^0 , θ^0 , and e_y^0 are functions of the position along the centerline of the equivalent continuum beam model. Consequently, the strain components can be expressed as follows:

$$e_x = \frac{du}{dx} = \partial u \quad (3.3)$$

$$e_x^0 = \frac{du^0}{dx} = \partial u^0 \quad (3.4)$$

$$k_x^0 = \frac{d\theta^0}{dx} = \partial \theta^0 \quad (3.5)$$

$$e_y = \frac{dv}{dy} \quad (3.6)$$

$$e_y^0 = \frac{dv^0}{dy} \quad (3.7)$$

$$\begin{aligned} \gamma_{xy}^0 &= \theta^0 + \frac{dv^0}{dx} + y \frac{de_y^0}{dx} \\ &= \theta^0 + \partial u^0 + y \partial e_y^0 \end{aligned} \quad (3.8)$$

where γ_{xy}^0 is the shearing strain of the ordinary beam theory;

k_x^0 is the curvature change in the x direction; and

$\partial = \frac{\partial}{\partial x}$ is the derivative with respect to x .

Using the expressions defined in Equations (3.1) through Equation (3.8) with the additional constraint that compatibility at the interface of two repeating elements be satisfied (i.e. e_y^0 must be identical at the interface between any two adjacent elements, therefore, $\frac{de_y^0}{dx}$ must equal to zero), the strain expressions of the k^{th} member of the repeating element can be expressed as:

$$e_x^{(k)} = e_x^0 + \gamma^{(k)} k_x^0 \quad (3.9)$$

$$e_y^{(k)} = e_y^0 \quad (3.10)$$

$$\gamma_{xy}^{(k)} = \vartheta^0 + \frac{dv^0}{dx} = \vartheta^0 + \partial v^0 \quad (3.11)$$

3.3 Strain Energy of the Continuum Model

As previously discussed in Chapter II, the second step in the equivalent continuum approach is to write the strain energy equation of the planar truss in terms of geometric and material properties of the actual lattice structure. To perform this mathematical procedure, the axial strains in each member of the repeating element is determined by the following expression:

$$e^{(k)} = \sum_{i=1}^2 \sum_{j=1}^2 e_{ij}^{(k)} l_i^{(k)} l_j^{(k)} \quad (3.12)$$

where $e^{(k)}$ is the axial strain in the k^{th} member;

$e_{ij}^{(k)}$ are the strain components evaluated at the center of the k^{th} member in the coordinate direction; and

$l_i^{(k)}$, $l_j^{(k)}$ are the direction cosines of the k^{th} member.

Therefore, the strain energy of the repeating element can be expressed as follows:

$$U = \frac{1}{2} \sum_{\text{members}} E^{(k)} A^{(k)} L^{(k)} (e^{(k)})^2 \quad (3.13)$$

where $e^{(k)}$ is the axial strain in the k^{th} member;

E is the elastic modulus;

A is the member cross sectional area; and

L is the length of the k^{th} member of the repeating element.

The strain energy of the repeating element is obtained by substituting the strain equation given by (3.12) into equation (3.13). Therefore, the strain energy expressions for the individual members of the repeating

element of this particular truss as illustrated in Figure 3.1 can be written as follows:

$$\begin{aligned}
 U^{(1)} &= \frac{1}{2} EAL \left(e_x^o + \frac{h}{2} k_x^o \right)^2 \\
 U^{(2)} &= \frac{1}{2} EAL \left(e_x^o - \frac{h}{2} k_x^o \right)^2 \\
 U^{(3)} &= \frac{1}{4} EAh \left(e_y^o \right)^2 \\
 U^{(4)} &= \frac{1}{4} EAh \left(e^o \right)^2 \\
 U^{(5)} &= \frac{1}{2} EAD \left(e_x^o \left(\frac{L}{D} \right)^2 + e_y^o \left(\frac{h}{D} \right)^2 + \frac{Lh}{D^2} \gamma_{xy}^o \right)^2
 \end{aligned} \tag{3.14}$$

where D , h , L are the diagonal, height, and the length of the repeating element, respectively.

Equations 3.14 are quadratic equations of the strain parameters, which can be expressed in the following matrix form:

$$U = \frac{1}{2} \{e\}^t [C_{ij}] \{e\} \tag{3.15}$$

where $[C_{ij}]$ is the matrix of the continuum stiffness coefficients; and $\{e\}$ is the strain vector.

However, in order to obtain the stiffness coefficients of the equivalent continuum, the strain energy expression given by Equation (3.15) has to be differentiated twice with respect to the associated strains. In other words, C_{ij} can be expressed as:

$$C_{ij} = \frac{d^2U}{de_i de_j} \tag{3.16}$$

Performing this operation on Equation (3.15) yields the set of stiffness coefficients for the equivalent continuum beam model. Therefore, the algebraic equations relating the forces and moments in the

continuum model to its corresponding strains can be expressed as follows:

$$\begin{bmatrix} N_x \\ M_x \\ Q_x \\ N_y \end{bmatrix} = \begin{bmatrix} c_{11} & c_{12} & c_{13} & c_{14} \\ & c_{22} & c_{23} & c_{24} \\ \text{symmetric} & & c_{33} & c_{34} \\ & & & c_{44} \end{bmatrix} \begin{bmatrix} e_x^o \\ k_x^o \\ \gamma_{xy}^o \\ e_y^o \end{bmatrix} \quad (3.17)$$

where N_x is the axial force;

M_x is the bending moment;

Q_x is the transverse shearing force; and

N_y is the force associated with the asymmetric shearing strain of the continuum.

The values of c_{ij} are listed in Table 3.1.

In general, to reduce the continuum beam theory to represent ordinary shear deformation beam theory, the continuum theory is further simplified by eliminating all forces that account for the local member deformation which must occur freely in the actual structure (11).

The strain energy of the planar truss considered can be written in the following functional form:

$$U = U(e_x^o, k_x^o, \gamma_{xy}^o, \underline{e_y^o}, \underline{\frac{de_x^o}{dx}}, \underline{\frac{dk_x^o}{dx}}, \underline{\frac{d\gamma_{xy}^o}{dx}}, \underline{\frac{d^2e_y^o}{dx^2}}) \quad (3.18)$$

The underlined terms in this functional relationship are associated with local member deformation of the planar truss. The forces associated with these strain components are eliminated by setting the derivative of the strain energy with respect to these terms equal to zero as follows:

| C_{ij} | $= \Sigma \frac{d^2U}{de_i de_j}$ |
|-------------------|--|
| C_{11} | $EAL \left(2 + \frac{(L)^3}{D} \right)$ |
| $C_{12} = C_{21}$ | 0 |
| $C_{13} = C_{31}$ | $EAH \frac{(L)^3}{D^3}$ |
| $C_{14} = C_{41}$ | $EA \frac{h^2 L^2}{D^3}$ |
| C_{22} | $\frac{1}{2} EAL h^2$ |
| $C_{23} = C_{32}$ | 0 |
| $C_{24} = C_{42}$ | 0 |
| C_{33} | $EA \frac{L^2 h^2}{D^3}$ |
| $C_{34} = C_{43}$ | $EA \frac{h^3 L^3}{D^3}$ |
| C_{44} | $EAh \left(1 + \frac{(h)^3}{D^3} \right)$ |

TABLE 3.1 - CONTINUUM STIFFNESS COEFFICIENTS FOR PLANAR TRUSS CONSIDERED

$$\frac{\partial U}{\partial \left(\frac{de_x^0}{dx}\right)} = \frac{\partial U}{\partial \left(\frac{dk_x^0}{dx}\right)} = \frac{\partial U}{\partial \left(\frac{d\gamma_{xy}^0}{dx}\right)} = \frac{\partial U}{\partial \left(\frac{d^2e_y^0}{dx^2}\right)} = \frac{\partial U}{\partial e_y^0} = 0 \quad (3.19)$$

This will result in five equations which express the strain gradients $\frac{de_x^0}{dx}$,

$\frac{dk_x^0}{dx}$, $\frac{d\gamma_{xy}^0}{dx}$, $\frac{d^2e_y^0}{dx^2}$, and e_y^0 in terms of the other three strain components

e_x^0 , k_x^0 , and γ_{xy}^0 . The resulting strain energy expression can be written as:

$$U = \frac{\bar{L}}{2} \{e\}_{1 \times 3}^t [\bar{c}_{ij}]_{3 \times 3} \{e\}_{3 \times 1} \quad (3.20)$$

where $\{e\}^t$ is the strain vector $[e_x^0 \quad k_x^0 \quad \gamma_{xy}^0]$;

\bar{L} is the length of the repeating section;

$[\bar{c}_{ij}]_{3 \times 3}$ is the matrix of the equivalent stiffness coefficients of the continuum model.

Upon completion of this mathematical operation, as presented in Appendix A, the force displacement relationships can be expressed as follows:

$$\begin{bmatrix} N_x \\ M_x \\ Q_x \end{bmatrix} = \begin{bmatrix} \bar{c}_{11} & 0 & 0 \\ 0 & \bar{c}_{22} & 0 \\ 0 & 0 & \bar{c}_{33} \end{bmatrix} \begin{bmatrix} e_x^0 \\ k_x^0 \\ \gamma_{xy}^0 \end{bmatrix} \quad (3.21)$$

where \bar{c}_{11} is the extensional stiffness coefficient;

\bar{c}_{22} is the bending stiffness coefficient;

\bar{c}_{33} is the transverse shearing stiffness coefficient of the equivalent continuum beam model of the parrot truss considered.

Since the origin of the coordinate axes is chosen at the centroid of the repeating element, there is no coupling terms between the equivalent stiffness coefficients. This specific location is found to be the most suitable and effective location for the origin in all repetitive lattice structures.

The algebraic values of the equivalent stiffness coefficients for the planar truss considered are listed in Table 3.2.

3.4 Kinetic Energy of the Equivalent Continuum Model

In the free vibration analysis of the lattice structure, it is necessary to compute an equivalent mass matrix for the continuum model. This, as previously discussed in Chapter II, is developed from the kinetic energy expression.

The kinetic energy of the equivalent continuum model can be expressed in terms of the displacement parameters u^0 , v^0 , θ^0 . In mathematical form, the kinetic energy can be expressed as:

$$T = T(u^0, v^0, \theta^0) \quad (3.22)$$

Since the kinetic energy is a quadratic function in the displacements and rotational components, it can be written in the following matrix form:

$$T = \frac{1}{2} \{\dot{d}\}^t [\bar{m}_{ij}] \{\dot{d}\} \quad (3.23)$$

where $\{\dot{d}\}^t$ is the velocity vector; and

$[\bar{m}_{ij}]$ is the matrix of the equivalent mass coefficients.

The equivalent mass coefficients of the continuum model are obtained by differentiating the kinetic energy expression twice with respect to

| PLANAR TRUSS | |
|--------------|--|
| L^- | = L |
| C_{11}^- | 2 EA |
| C_{22}^- | $\frac{1}{2} EA h^2$ |
| C_{33}^- | $\frac{EALh^2}{D^3} \left(1 - \frac{L^3}{L^3 + 2D^3} \right)$ |

TABLE 3.2 - ENGINEERING EQUIVALENT STIFFNESS COEFFICIENTS FOR PLANAR TRUSS CONSIDERED

the corresponding velocities parameters. This is expressed in mathematical form as:

$$\bar{m}_{ij} = \frac{1}{L} \left(\frac{\partial^2 T}{\partial \dot{d}_i \partial \dot{d}_j} \right) \quad (3.24)$$

Based upon a consistent mass approach, the kinetic energy expression for the repeating element of a planar truss can be expressed according to Noor and Anderson (11) as follows:

$$T = \frac{1}{6} \omega^2 \sum \rho^{(k)} A^{(k)} L^{(k)} \left[(u_i)^2 + u_i u_j + (u_j)^2 + (v_i)^2 + v_i v_j + (v_j)^2 \right] \quad (3.25)$$

where ρ is the mass density of the k^{th} member which joining node numbers i and j ; ω is the natural frequency of vibration.

In order to obtain the equivalent mass coefficients, equations (3.1) and (3.2) are substituted in the kinetic energy expression (3.25). The inertia terms associated with e_y^0 have insignificant effect on the lower modes of free vibration (11) and are, therefore, neglected. From the structural point of view, these lower modes do not significantly contribute to the free vibration analysis of typical civil engineering structures i.e. towers, buildings, etc.

Therefore, with some algebraic simplification, the kinetic energy of the planar truss continuum model considered can be expressed in terms of the displacement parameters as:

$$T = \frac{\omega^2}{L} \left[\bar{m}_{11} (u^0)^2 + \bar{m}_{22} (v^0)^2 + \bar{m}_{33} (\theta^0)^2 \right] \quad (3.26)$$

where \bar{m}_{11} is the extensional mass density coefficient in the x direction;
 \bar{m}_{22} is the extensional mass density coefficient in the y direction;
 \bar{m}_{33} is the density of the mass rotatory inertia coefficient of the

equivalent beam model; and

\bar{L} is the length of the repeating element of the planar truss considered.

These equivalent mass coefficients of the planar truss considered are listed in Table 3.3. Moreover, the development of these coefficients is fully presented in Appendix A.

3.5 Work Done by External Forces

The expression for the work done by external forces (11) consistent with the kinematic hypothesis presented in this chapter can be expressed as follows:

$$\text{Work} = \sum_{i=1}^n [P_x^i (u^0 + y^i \theta^0) + P_y^i (v^0 + y^i e_y^0)] \quad (3.27)$$

where P_x^i , P_y^i are the external nodal load components in x and y directions, respectively, at the i^{th} node of the lattice structure.

The total work done by the external nodal forces is obtained by summing the contributions over the entire lattice structure. A comparison between the work done by external forces on a discrete lattice structure and that on the equivalent continuum model indicates very good agreement between the two models (11).

3.6 Evaluation of Member Forces from Continuum Model Solution of Planar Truss

One of the problems which the structural designer faces when using the continuum modeling approach is the calculation of actual member forces of the discrete structure from equivalent beam results. This study presents a simple rational technique to calculate these forces.

| $L^- = L$ | |
|----------------|--|
| \bar{m}_{11} | $\rho A \left(2 + \frac{h}{L} + \frac{D}{L} \right)$ |
| \bar{m}_{22} | $\rho A \left(2 + \frac{h}{L} + \frac{D}{L} \right)$ |
| \bar{m}_{33} | $\frac{1}{2} \rho A h^2 \left(1 + \frac{h + D}{6L} \right)$ |

TABLE 3.3 - EQUIVALENT MASS COEFFICIENTS
FOR PLANAR TRUSS CONSIDERED

The procedures to obtain the member forces from the equivalent model results can be summarized in the following steps:

1. From the equivalent continuum model determine the displacement u , v and θ of the nodes in the equivalent continuum that correspond to those nodes of the member under consideration.
2. Substitute these displacements into the following linear displacement relationships for the planar truss:

$$u_i = u_i^0 \pm \bar{z}_i \theta_i^0 \quad (3.28)$$

$$v_i = v_i^0 \pm \bar{z}_i \theta_i^0 \quad (3.29)$$

where u_i^0 , v_i^0 , and θ_i^0 are the horizontal displacements, vertical displacement, and rotational displacement at node i of the equivalent continuum model; and \bar{z} is the vertical distance from the centroid of the repeating section to the node under consideration.

3. The change in length ΔL_{ij} of member (ij) is obtained by:

$$\Delta L_{ij} = l(u_i - u_j) + m(v_i - v_j) \quad (3.30)$$

where l and m are the direction cosines of member (ij) in the x and y directions, respectively.

4. The strain in member (ij) is given by:

$$e_{ij} = \frac{\Delta L_{ij}}{L_{ij}} \quad (3.31)$$

where L_{ij} is the length of member (ij) .

5. The stress σ_{ij} of member (ij) is expressed in the classical manner as:

$$\sigma_{ij} = E_{ij} e_{ij} \quad (3.32)$$

where E_{ij} is the elastic modulus of member (ij).

6. The force F_{ij} is then determined by the following expression:

$$F_{ij} = \sigma_{ij} A_{ij} \quad (3.33)$$

where A_{ij} is the cross sectional area of member (ij).

A comparative study between member forces obtained from the continuum model solution and those obtained from the analysis of the actual lattice structure is presented in the following section.

3.7 Numerical Studies of Planar Truss

The purpose of this section is to assess the accuracy of the equivalent continuum model approach in predicting static as well as free vibration analysis of the planar trusses considered. A comparison is made between three individual static loadings which can be summarized as follows:

- an axial load;
- a transverse shear load; and
- a bending moment load.

Figure 3.2 illustrates the applications of these different loads on the two end bays of the planar truss considered. Figure 3.3 shows how the planar truss is simulated into an equivalent beam model along with its corresponding sign convention. In addition, Figure 3.3 demonstrates the application of the equivalent static loadings applied at the end node of

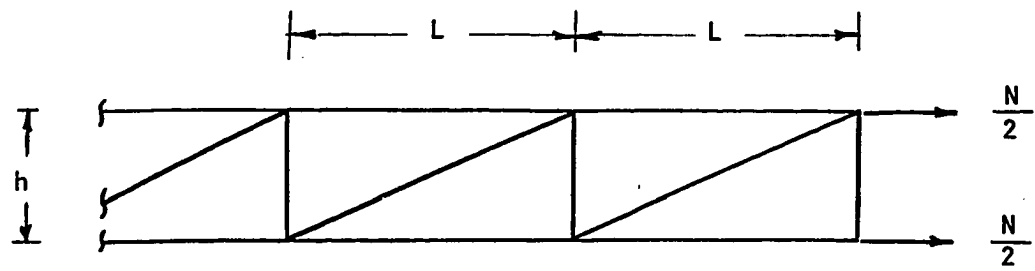

AXIAL LOADING

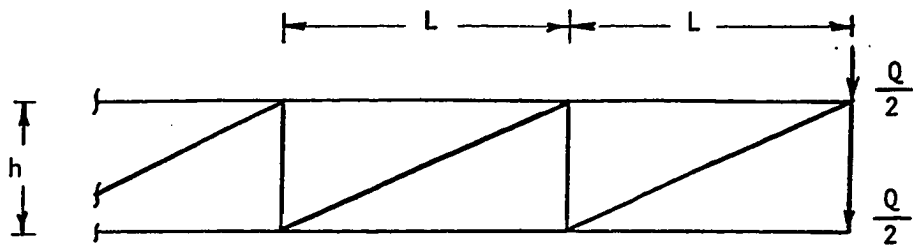

TRANSVERSE SHEAR LOADING

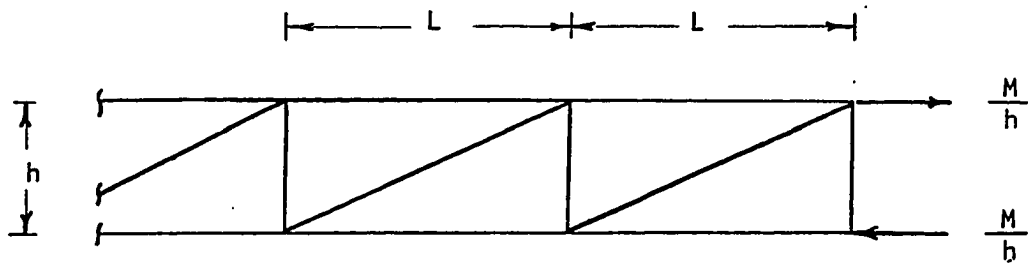

BENDING LOADING

FIGURE 3.2 - SYSTEMS OF STATIC LOADINGS
CONSIDERED IN THE PRESENT STUDY

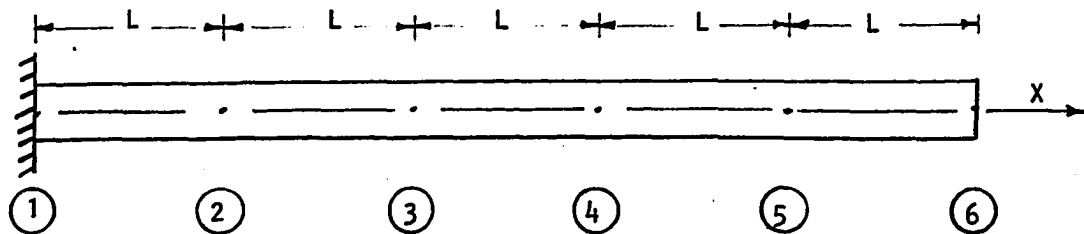

EQUIVALENT BEAM MODEL

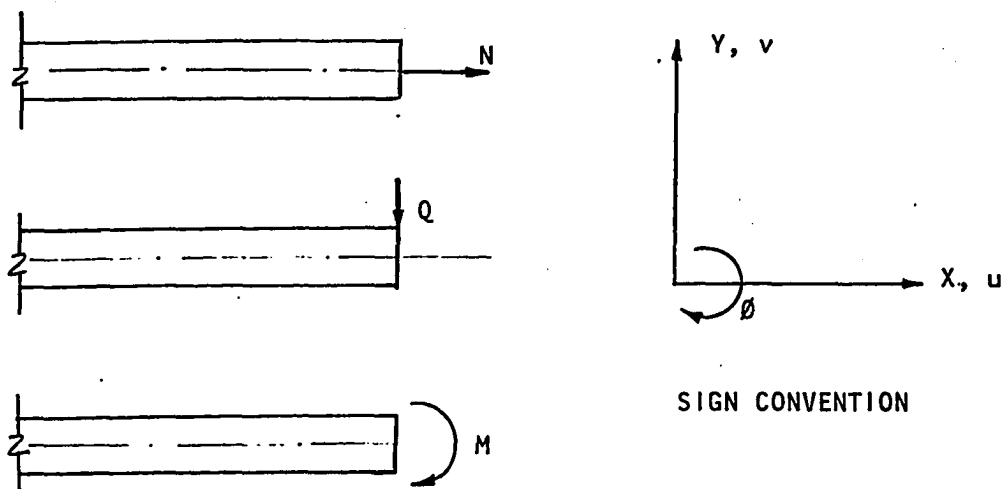

SIGN CONVENTION

STATIC LOADINGS
CONSIDERED

| FORCE | ASSOCIATED DISPLACEMENT |
|-------|----------------------------|
| N | u |
| Q | v |
| M | θ |

FIGURE 3.3 - CONTINUUM MODEL STATIC LOADINGS
AND SIGN CONVENTION

the equivalent beam centerline. Included in this figure is a table summarizing the forces and associated displacements of the equivalent beam model. Since the interior battens geometric properties are assumed to be shared equally between the two adjacent repeating elements, the vertical batten member at the free end of the planar truss is considered to have one-half of the geometric properties of the interior battens.

SAP IV (12), a standard finite element computer program, is used in this study to analyze the actual structural and the equivalent continuum beam model. The key step in performing the numerical analysis is the simulation of the equivalent properties of the continuum model for input into the SAP IV program. In the case of the planar truss considered, the equivalent properties which accommodate SAP (IV) input data can be extracted from the equivalent continuum stiffness and mass coefficients as follows:

Equivalent axial area

$$\begin{aligned} A_{EQ} &= \frac{\bar{C}_{11}}{E} \\ &= \frac{2EA}{E} = 2A \end{aligned} \quad (3.34)$$

Equivalent moment of inertia

$$\begin{aligned} I_{EQ} &= \frac{\bar{C}_{22}}{E} \\ &= \frac{2EA}{E} \left(\frac{h}{2}\right)^2 \\ &= \frac{1}{2} Ah^2 \end{aligned} \quad (3.35)$$

Equivalent shear area

$$A_{sh} = \frac{\bar{C}_{33}}{G}$$

$$= \frac{2ALh^2}{D^3} (1+\nu) \left(1 - \frac{L^3}{L^3 + 2D^3}\right) \quad (3.36)$$

where G is the shear modulus; and

ν is poisson's ratio.

Equivalent translational mass coefficient in x-direction

$$F_{(EQ)_x} = \bar{m}_{11} \bar{L} \quad (3.37)$$

Equivalent translational mass coefficient in y-direction

$$F_{(EQ)_y} = \bar{m}_{22} \bar{L} \quad (3.38)$$

Equivalent rotational inertia in the plane of the cross section of the equivalent beam model

$$M_{EQ} = \bar{m}_{33} \bar{L} \quad (3.39)$$

Comparison of the displacement results under the three static loading conditions between the equivalent continuum model and the finite element solution indicates a very high degree of reliability. Specifically, the nodal displacements for the axial loading conditions are in excellent agreement to within .001%. These results are illustrated in Table 3.4. The displacement results obtained by the continuum method under a transverse loading (refer to Table 3.5) are also in excellent agreement with those obtained by the finite element method. Specifically, the end nodal displacement agreed to within 0.30%. The results of the third load

| NODE NO. | u_{EQ} (FT.) | u_{ACT} (FT.) |
|----------|--------------------------|---------------------------|
| 1 | 0.00 | 0.00 |
| 2 | 0.14993×10^{-4} | 0.14993×10^{-4} |
| 3 | 0.29985×10^{-4} | 0.29985×10^{-4} |
| 4 | 0.44978×10^{-4} | 0.44978×10^{-4} |
| 5 | 0.59971×10^{-4} | 0.59971×10^{-4} |
| 6 | 0.74964×10^{-4} | 0.749635×10^{-4} |

$$\begin{aligned} \text{EXACT DISPLACEMENT AT FREE END} &= \frac{PL}{AE} \cong \frac{PL}{C_{11}} \\ &\cong 0.74964 \times 10^{-4} \text{ FT.} \end{aligned}$$

TABLE 3.4 - ACCURACY OF DISPLACEMENTS OBTAINED BY THE EQUIVALENT BEAM MODEL FOR PLANAR TRUSS CONSIDERED DUE TO UNIT AXIAL LOADING.

| NODE NO. | v_{EQ} (FT.) | v_{ACT} (FT.) |
|----------|--------------------------|--------------------------|
| 1 | 0.00 | 0.00 |
| 2 | 0.11728×10^{-2} | 0.11772×10^{-2} |
| 3 | 0.38449×10^{-2} | 0.38596×10^{-2} |
| 4 | 0.76415×10^{-2} | 0.76664×10^{-2} |
| 5 | 0.12188×10^{-1} | 0.12223×10^{-1} |
| 6 | 0.17109×10^{-1} | 0.17154×10^{-1} |

$$\begin{aligned}
 \text{EXACT DISPLACEMENT AT FREE END} &= \frac{PL^3}{3EI} + \int \frac{Q_1 q}{L GA} dx \\
 &\cong \frac{PL^3}{C_{22}} + \frac{L}{C_{33}} \\
 &\cong 0.17108 \times 10^{-1} \text{ FT.}
 \end{aligned}$$

TABLE 3.5 - ACCURACY OF DISPLACEMENTS OBTAINED BY THE EQUIVALENT BEAM MODEL FOR PLANAR TRUSS CONSIDERED DUE TO A UNIT SHEAR LOADING.

case - unit bending moment exemplifies further the excellent reliability of the continuum model. The results of this analysis shown in Table 3.6 indicate, as in the other loadings, a very high degree of accuracy. Specifically, the results of the continuum analysis are precisely the same. In addition, as illustrated in Tables 3.4 through 3.6, a structural analyst can obtain excellent approximate deflection by simple manual calculations using exact expressions for the deflection of cantilever beam and the equivalent geometric and material properties obtained by the continuum modeling approach. This will be of a considerable assistance to the structural designer in preliminary phases of the design process.

Although the high accuracy of the results obtained by the continuum model analysis is of great importance, nevertheless of more significance is the computational efficiency of the continuum model approach versus the classical finite element method. Specifically, the computer time (as measured by CPU time units on a DEC 10 computer) for the equivalent continuum analysis was 1.18 seconds; whereas, for the more exact finite element solution the CPU time was 1.31 seconds. This represents a 10% approximate savings in computer time. Another example of a ten-bay planar truss was considered in the present study and its static analysis indicates over 20% approximate saving in computer time. Therefore, it should be noted that computer time saving will increase significantly as the number of repeating elements increases in the problem considered. This fact is also demonstrated by Noor and Anderson (11) throughout their numerical studies. In addition to this savings in computer time, there will be an additional savings in man-hours during the preparation of input data when using the equivalent continuum modeling technique.

| NODE NO. | v_{EQ} (FT) | v_{ACT} (FT) |
|----------|--------------------------|--------------------------|
| 1 | 0.00 | 0.00 |
| 2 | 0.18741×10^{-4} | 0.18740×10^{-4} |
| 3 | 0.74964×10^{-4} | 0.74962×10^{-4} |
| 4 | 0.16867×10^{-4} | 0.16867×10^{-4} |
| 5 | 0.29985×10^{-3} | 0.29985×10^{-3} |
| 6 | 0.46852×10^{-3} | 0.46852×10^{-3} |

$$\begin{aligned} \text{EXACT DISPLACEMENT AT FREE END} &= \frac{ML^2}{2EI} \cong \frac{ML^2}{2\bar{C}_{22}} \\ &\cong 0.46852 \times 10^{-3} \text{ FT.} \end{aligned}$$

TABLE 3.6 - ACCURACY OF DISPLACEMENTS OBTAINED BY THE EQUIVALENT BEAM MODEL FOR PLANAR TRUSS CONSIDERED DUE TO UNIT BENDING MOMENT LOADING.

The results for the free vibration analysis of the planar truss using the continuum model compared to the analysis using the finite element technique are illustrated in Table 3.7. This table specifically compares the natural frequencies using the two methods for the first five modes of vibrations. The difference in natural frequencies between the two methods for the first two modes is less than 0.5%, whereas, this difference increases to 1.4% for the third mode and to 4.85% for the fifth mode. It would appear from these results that the continuum modeling approach poorly represents the energies in the higher modes. However, in the analysis of free vibration response for nearly all civil engineering structural problems, special attention is given primarily to the first fundamental mode of vibration. Thereby, the continuum modeling approach is a very reliable method of analysis for the free vibration response of repetitive structures.

Figure 3.4 illustrates the first three bending mode shapes as obtained from the continuum model analysis. This figure shows the first three mode shapes of the equivalent continuum model which in general represents the first three mode shapes of a cantilever beam. In addition, depicted in Figure 3.5 is a comparison of natural frequencies ratios of the first three extensional modes along with the first three bending modes. As previously mentioned, the error increases going from the fundamental mode to the higher modes.

As with the static analysis, there is considerable computational efficiency in using the continuum modeling approach versus the classical finite element technique. Specifically, the computer time for the continuum solution was 1.48 seconds; whereas, for the finite element solution it was 1.78 seconds. This savings will increase as the size of

| MODE NO. | ω_{EQ} RAD/SEC | ω_{ACT} RAD/SEC | Δ % |
|----------|-----------------------|------------------------|------------|
| 1 | 32.28 | 32.34 | 0.18 |
| 2 | 144.70 | 145.30 | 0.41 |
| 3 | 297.40 | 301.60 | 1.39 |
| 4 | 393.60 | 406.90 | 4.40 |
| 5 | 417.50 | 438.80 | 4.85 |

CPU (SEC)

1.48

1.78

TABLE 3.7 - NATURAL FREQUENCIES AND COMPUTER TIME COMPARISON BETWEEN FINITE ELEMENT AND EQUIVALENT BEAM MODEL OF PLANAR TRUSS CONSIDERED

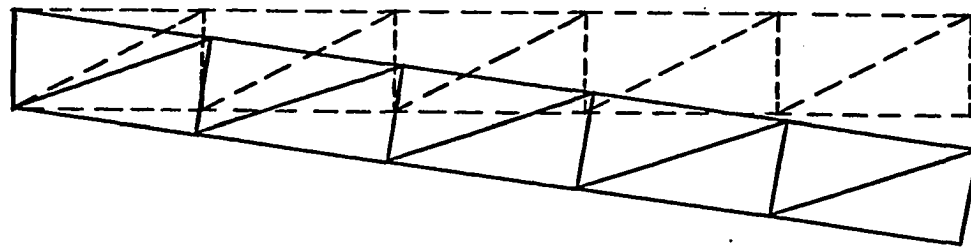

$$\omega_1 = 32.34 \text{ rad/sec}$$

FIRST MODE SHAPE

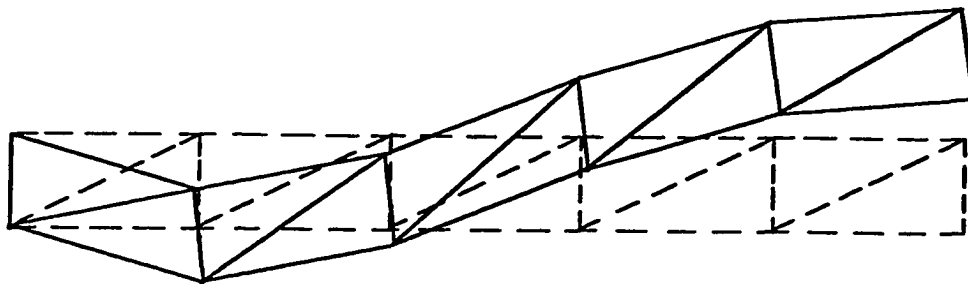

$$\omega_2 = 145.30 \text{ rad/sec}$$

SECOND MODE SHAPE

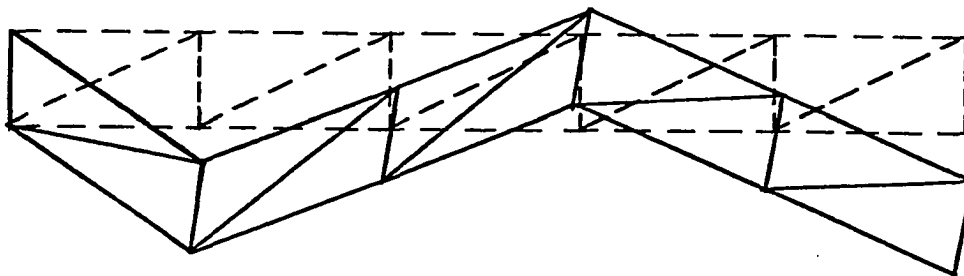

$$\omega_3 = 301.60 \text{ rad/sec}$$

THIRD MODE SHAPE

FIGURE 3.4 - FREE VIBRATION MODE SHAPES FOR FIVE BAY CANTILEVERED PLANAR TRUSS

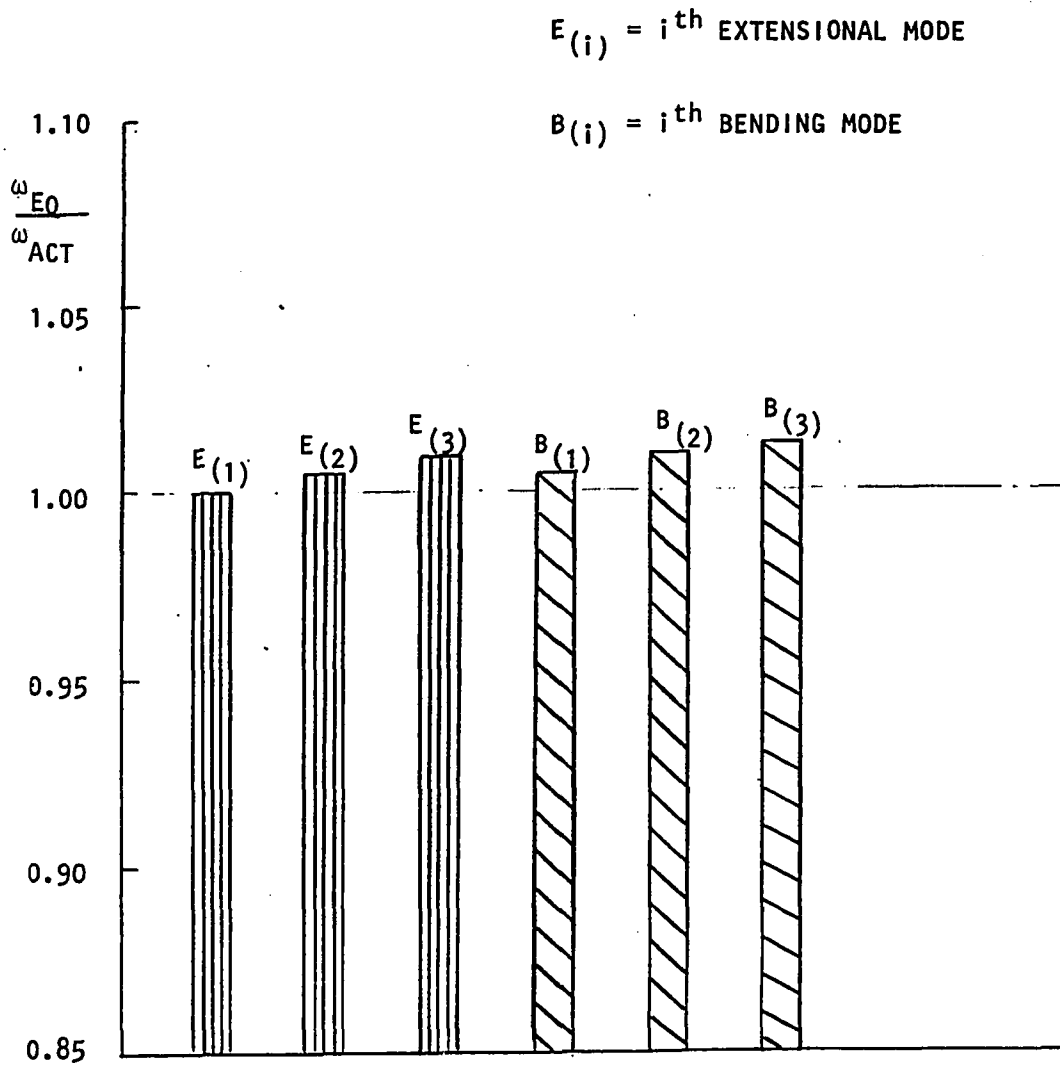

FIGURE 3.5 - BAR GRAPH DISPLAYING COMPARATIVE ACCURACY OF LOW FREQUENCIES OBTAINED BY THE EQUIVALENT BEAM MODEL FOR THE PLANAR TRUSS

the problem increases as was indicated from the analysis of the ten-bay planar truss considered herein, and also as the studies conducted by Noor and Anderson (11) have concluded.

To illustrate the accuracy of the continuum model results in calculating actual member forces of the structure, different members of the planar truss illustrated in Figure 3.1 are analyzed. Following the procedures outlined in Section 3.6, the force in the upper chord member 13 connecting joints (2) and (3) due to the application of 1.0 kip axial load is calculated as follows:

$$\begin{aligned}
 u_2 &= 0.14993 \times 10^{-4} \text{ ft.} & , & & u_3 &= 0.29985 \times 10^{-4} \text{ ft.} \\
 \Delta L &= (u_2 - u_3) \cos \theta & = & & 0.14992 \times 10^{-4} & \text{ ft.} \\
 e &= \frac{\Delta L}{L} & = & & 0.14992 \times 10^{-5} & \\
 \sigma &= e E & = & & 0.14992 \times 10^{-5} \times 4176000 & \\
 & & = & & 6.2507 & \text{ ksf} \\
 F &= A \sigma & = & & 0.4999 & \text{ kips}
 \end{aligned}$$

Actual force in member 13 from finite element results is 0.5 kips. This result shows 0.02% difference between the two solutions. The force in the vertical member connecting joints (5) and (6) due to unit moment at the free end can be obtained in a similar fashion as:

$$\begin{aligned}
 v_3 &= 0.74964 \times 10^{-4} \text{ ft} & ; & & \theta_3 &= 0.7496 \times 10^{-5} \text{ rad.} \\
 v_6 &= v_3 + \bar{z} \theta_3 \\
 &= .74964 \times 10^{-4} + 2 (.7496 \times 10^{-5}) \\
 &= .89956 \times 10^{-4} \text{ ft.}
 \end{aligned}$$

Similarly:

$$\begin{aligned}v_5 &= .7496 \times 10^{-4} - 2(.7496 \times 10^{-5}) \\ &= 0.60026 \times 10^{-4} \text{ ft.}\end{aligned}$$

$$\begin{aligned}\Delta L &= (v_6 - v_5) \cos 90 \\ &= 0\end{aligned}$$

Therefore, $e = \sigma = F = 0$

In other words, this particular member is a zero member under this condition of loading as the actual finite element results exactly indicated.

In summary, the results of static and free vibration analyses of the truss considered have illustrated the high accuracy of the equivalent continuum approach. This approach is a very attractive technique for structural engineers in obtaining accurate responses for lattice type structures at a significant saving in computational cost and man hours.

CHAPTER IV
APPLICATIONS TO TOWERS WITH TRIANGULAR
CROSS SECTIONS

4.1 General Remarks

The purpose of this chapter is to present the application of the continuum model approach to towers with constant triangular cross sections as well as towers with variable triangular cross sections. Chui and Taoka (17) conducted theoretical and experimental studies for an actual three legged tower using direct methods for the static analysis and modal superposition for a forced response dynamic analysis. The objective of their study was to find out the critical modes of vibration for the free standing triangular tower. The assumptions used in their analysis can be summarized as follows:

1. The tower is a linear elastic space truss;
2. Motion in any two orthogonal horizontal directions are uncoupled;
3. Masses are concentrated at nodal points;
4. Loads are applied only at panel points;
5. Vertical motions and secondary stresses are negligible; and
6. Tower base is assumed to be rigid.

The conclusion of their studies was that the fundamental mode of vibration predominates other modes of vibration in case of free standing triangular towers. In addition, their analysis indicated that the free standing triangular tower has fairly low damping ratio for the fundamental mode of vibration. Based on these findings, structural

damping has been neglected and the first three modes of free vibration have been considered in the present study.

As previously mentioned, this chapter is dealing with free standing triangular towers as illustrated in Figure 4.1 and Figure 4.2, but with a completely different approach from Chui and Taoka. As was discussed in Chapter II, this approach is based on equivalencing the strain and the kinetic energies of the actual repetitive structure to those of the equivalent continuum model. Static and free vibration analyses of free standing triangular towers with constant and variable cross sections are presented in this chapter along with results obtained indicating the effectiveness and the accuracy of the continuum solution. The finite element technique was successfully employed to make a comparison between the actual tower and the equivalent continuum model for both static and free vibration responses.

4.2 Characteristics of Free Standing Towers with Triangular Cross Sections

The configurations of free standing towers for which the equivalent continuum properties are developed are shown in Figure 4.1 and Figure 4.2. Nomenclature similar to those of planar truss is used to describe the three dimensional towers considered in the present study. The single bay double laced repeating section as depicted in Figure 4.3 and Figure 4.4 are the most commonly used for tower structures such as transmission and communication towers. This type of configuration is characterized by having no joints at midpoints of the core members which ultimately results in reducing the degree of complexity of the analysis. Other cases where intermediate nodes are present in the core members, their analysis indicated that these kinds of trusses cannot be

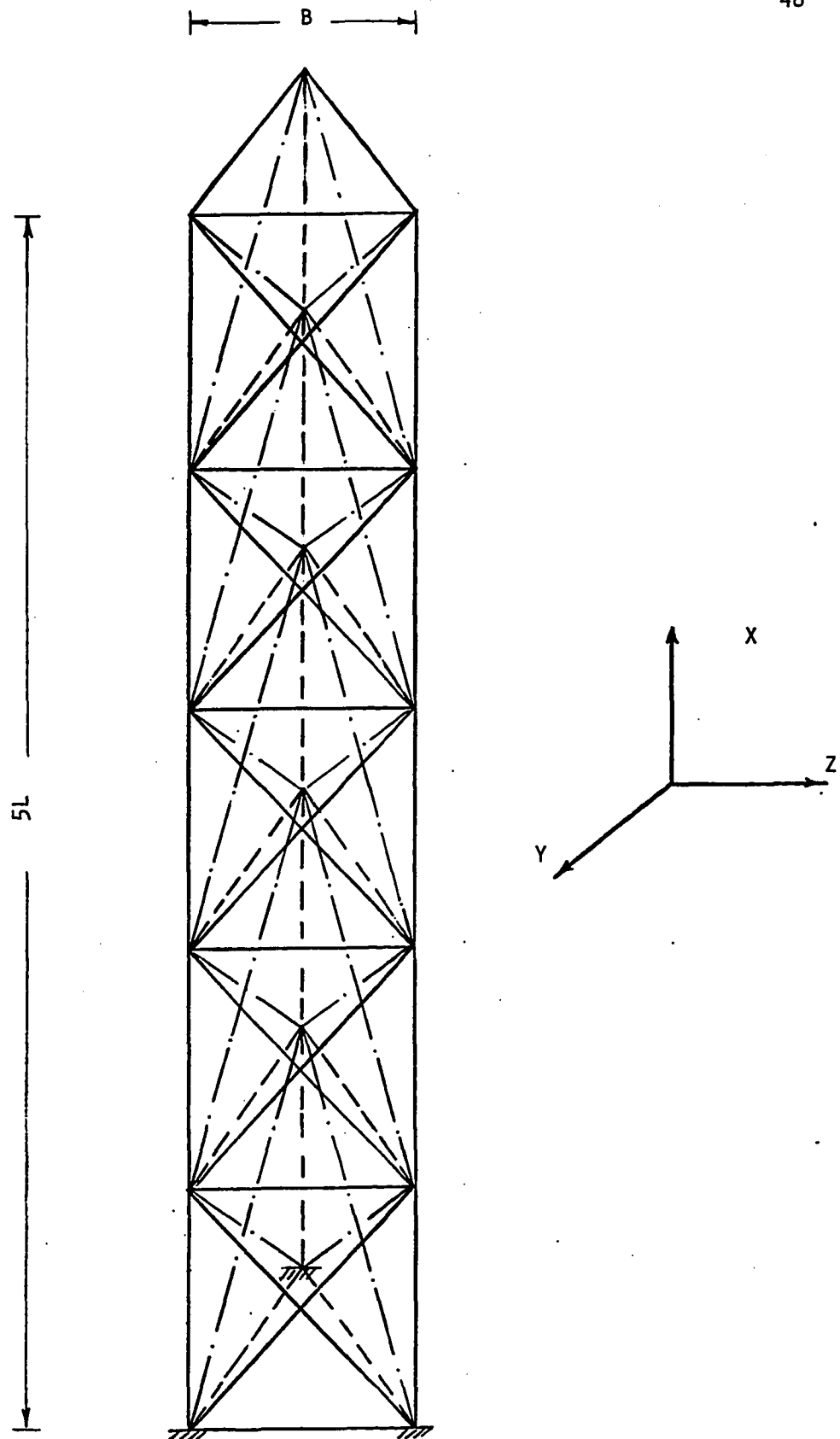

FIGURE 4.1 - FIVE BAYS TOWER WITH CONSTANT TRIANGULAR CROSS SECTION

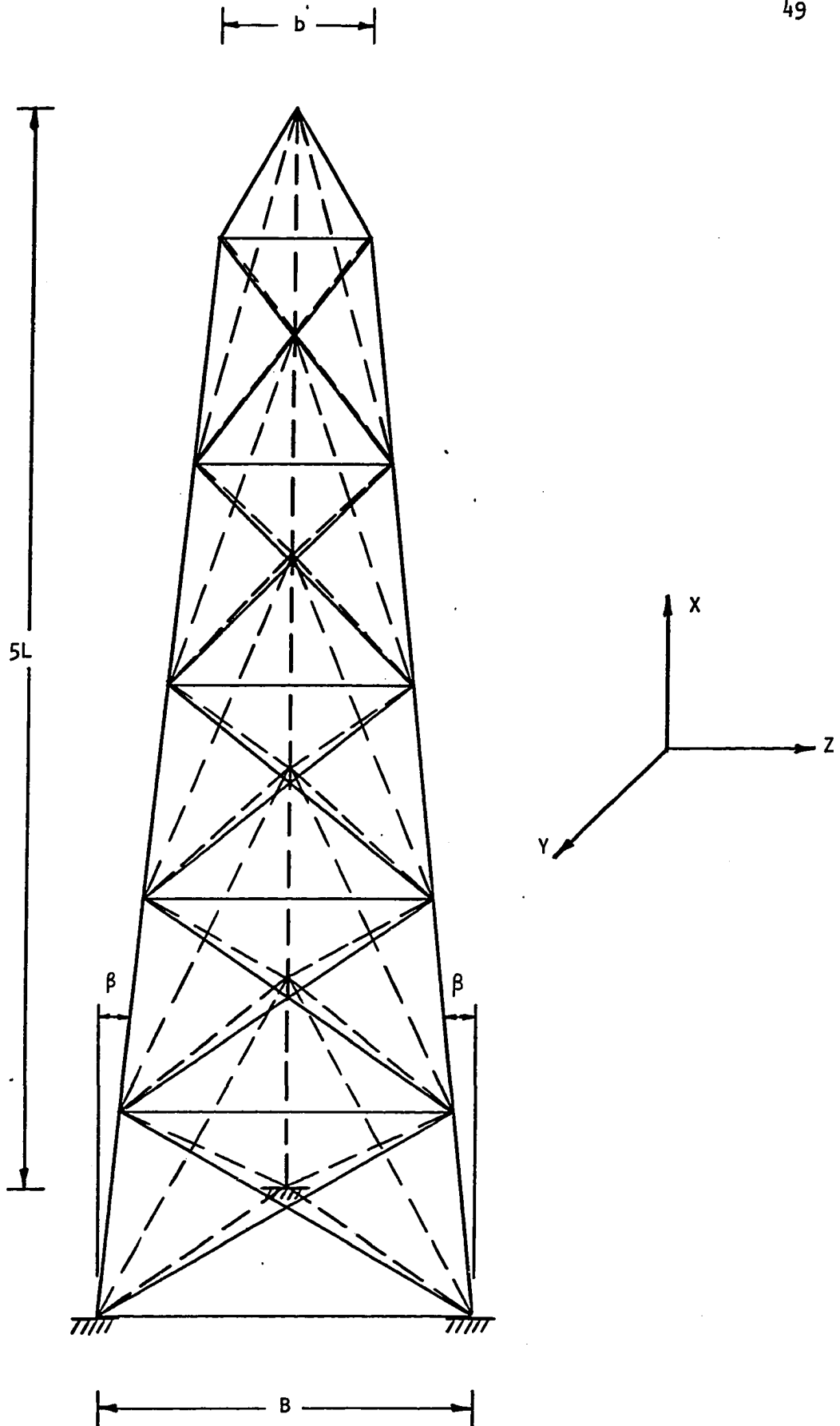
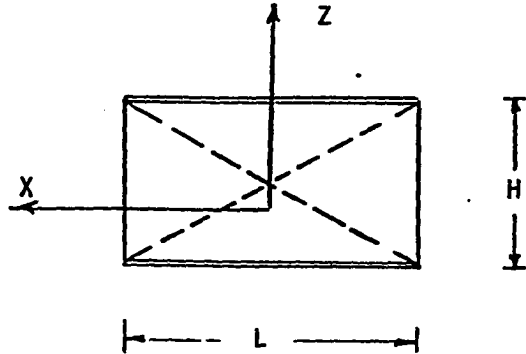
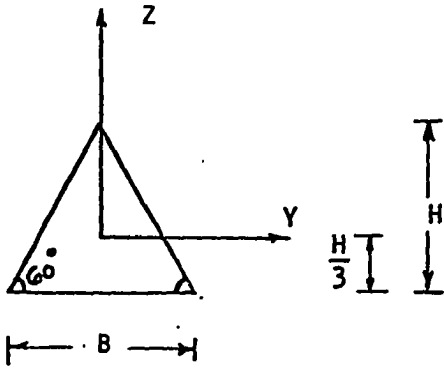

FIGURE 4.2 - FIVE-BAY DOUBLE LACED TOWER WITH VARIABLE TRIANGULAR CROSS SECTIONS



Number of Repeating Element (NR) = 5
 $E = 29000000.0 \text{ psi}$
 $\rho_l = \rho_b = \rho_d = 0.283 \text{ lb/in}^3$

Longitudinals are $L^5 \text{ } 5 \times 5 \times 5/16$
 $A_l = 3.03 \text{ in}^2$
 $L = 72.0 \text{ in.}$

Battens and Diagonal Members are $L3 \times 3 \times 1/4$
 $A_b = A_d = 1.44 \text{ in}^2$
 $B = 162.96 \text{ in.}$

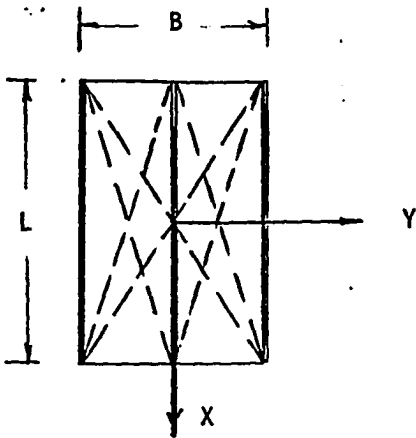

| MEMBERS | CROSS SEC. AREA | MOMENT OF INERTIA | MASS DENSITY | MEMBER LENGTH | DESIGNATION |
|--------------|-----------------|-------------------|--------------|---------------|-------------|
| LONGITUDINAL | A_l | I_l | ρ_l | L | |
| BATTEN | A_b | I_b | ρ_b | B | |
| DIAGONAL | A_d | I_d | ρ_d | D | |

FIGURE 4.3 - REPEATING ELEMENT OF DOUBLE LACED TRIANGULAR TOWER WITH CONSTANT CROSS SECTION AND ASSOCIATED MEMBER PROPERTIES.

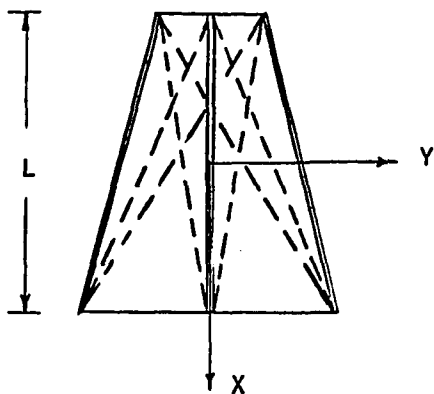
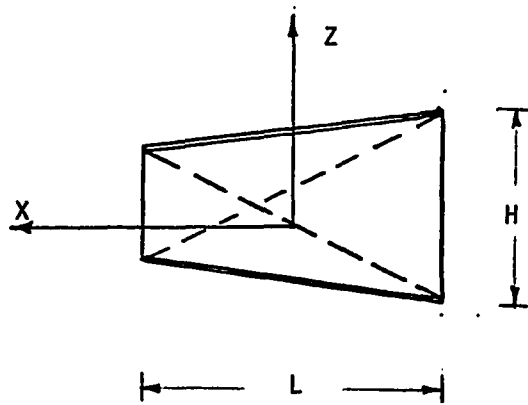
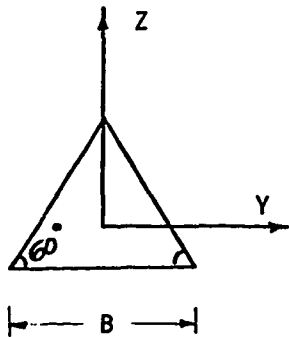

Number of Repeating Element (NR) = 5

$E = 29000000.0 \text{ psi}$

$\rho_l = \rho_b = \rho_d = 0.283 \text{ lb/in}^3$

Longitudinals are $L^S \text{ } 5 \times 5 \times 5/16$

$A_l = 3.03 \text{ in}^2$

$L = 72.0 \text{ in.}$

Battens and Diagonal Members are

$L3 \times 3 \times 1/4$

$A_b = A_d = 1.44 \text{ in}^2$

$B = 162.96 \text{ in.}$

| MEMBERS | CROSS SEC. AREA | MOMENT OF INERTIA | MASS DENSITY | MEMBER LENGTH | DESIGNATION |
|--------------|-----------------|-------------------|--------------|---------------|-------------|
| LONGITUDINAL | A_l | I_l | ρ_l | L | |
| BATTEN | A_b | I_b | ρ_b | B | |
| DIAGONAL | A_d | I_d | ρ_d | D | |

FIGURE 4.4 - REPEATING ELEMENT OF DOUBLE LACED TRIANGULAR TOWER WITH VARIABLE CROSS SECTION AND ASSOCIATED MEMBER PROPERTIES.

analyzed as a classical space truss with pin joints due to instability problems. This will occur because bending stiffness of the axial core members is required to maintain the overall stability of the repeating element assembly. In addition, a desirable feature of the single bay double laced configuration is that it exhibits no peculiar coupling between the different modes of deformation such as bending and shear coupling. Furthermore, the double lacing in the core adds redundancy to the structure, thus failure of a single member will not cause failure of the overall structure due to redistribution of loading among the other members of the lattice. This makes the double laced configuration a very attractive structural configuration and as such it is highly recommended for free standing towers from the practical engineering design perspective.

The continuum model approach reduces the three dimensional repeating element into a one dimensional equivalent beam element in which the displacement variation is assumed to be linear in the longitudinal direction of the repeating element.

In the present study, the continuum model approach has been applied to towers with sloping legs (thus, a variable triangular cross section). Special considerations are made to count for the effect of the sloping legs of the free standing triangular tower on its overall behavior. The displacement variation is considered to be linear in the plane of the cross section as well as along the members of the repeating element of the double laced triangular tower. Therefore, the stiffness and mass coefficients of the equivalent continuum are obtained as functions of the geometric and material properties as well as the sloping angle of the tower legs. Subsequently, as a result of introducing

the linear slope of the tower legs, bending-shear coupling terms appear in the equivalent stiffness coefficients. However, numerical studies conducted herein have indicated that these coupling terms do not have significant effect on the overall response of the tower and will not affect the final design of individual tower members. This result is important because classical finite element programs such as SAP IV do not provide entry for these coupling terms in the standard beam bending element.

4.3 Kinematic Assumptions and Displacement Relationships

The selection of necessary displacement functions for a free standing tower with triangular cross sections begins with a consideration of the displacements in the plane of the cross section. Therefore, since each of the displacement components has a linear variation along the pin-connected members of the repeating element, the three components of the double laced triangular tower are assumed to have a linear variation in the plane of the cross section. Based on this assumption, the displacement variation in the plane of the cross section can be expressed as given by Noor and Anderson (11) as follows:

$$u(x, y, z) = u^0 - y\theta_z + z\theta_y \quad (4.1)$$

$$v(x, y, z) = v^0 + ye_y^0 + z(e_{yz}^0 - \theta_x) \quad (4.2)$$

$$w(x, y, z) = w^0 + y(e_{yz}^0 + \theta_x) + ze_z^0 \quad (4.3)$$

where u^0 , v^0 , w^0 are the displacement components at the centroid of the repeating section i.e. at $y = z = 0$;

θ_x , θ_y , and θ_z are the rotational components;

e_y^0 and e_z^0 are the extensional components; and

e_{yz}^0 is the shearing strain in the plane of the tower cross section.

The sign convention for the displacement and rotation component along with forces and associated displacements of the continuum model are depicted in Figure 4.5. Therefore, the nine parameters u^0 , v^0 , w^0 , θ_x , θ_y , θ_z , e_y^0 , e_z^0 , and e_{yz}^0 are functions of the displacement along the centerline of the repeating element. For towers with triangular cross sections, the deformed position of any cross section is completely specified by the three displacement components of each node of the triangular cross section. In addition, each of the displacement components has a linear variation in the y and z plane of the cross section. Since there are a total of nine free parameters in the displacement expressions, this will provide an actual representation of the displacement field for the triangular towers depicted in Figure 4.1 and Figure 4.2.

As a consequence of the kinematic assumptions, the strain components also have a linear variation in the plane of the cross section. They can be expressed as the following functions of x as indicated in (11):

(Note all partials are with respect to x , i.e. $\partial = \frac{\partial}{\partial x}$)

$$\begin{aligned} e_{xx} &= \frac{\partial u}{\partial x} \\ &= \partial u^0 - y \partial \theta_z + z \partial \theta_y \end{aligned}$$

Therefore;

$$e_{xx} = e_x^0 - y k_y^0 + z k_z^0 \quad (4.4)$$

Similarly;

$$e_{yy} = \frac{\partial v}{\partial y} = e_y^0 \quad (4.5)$$

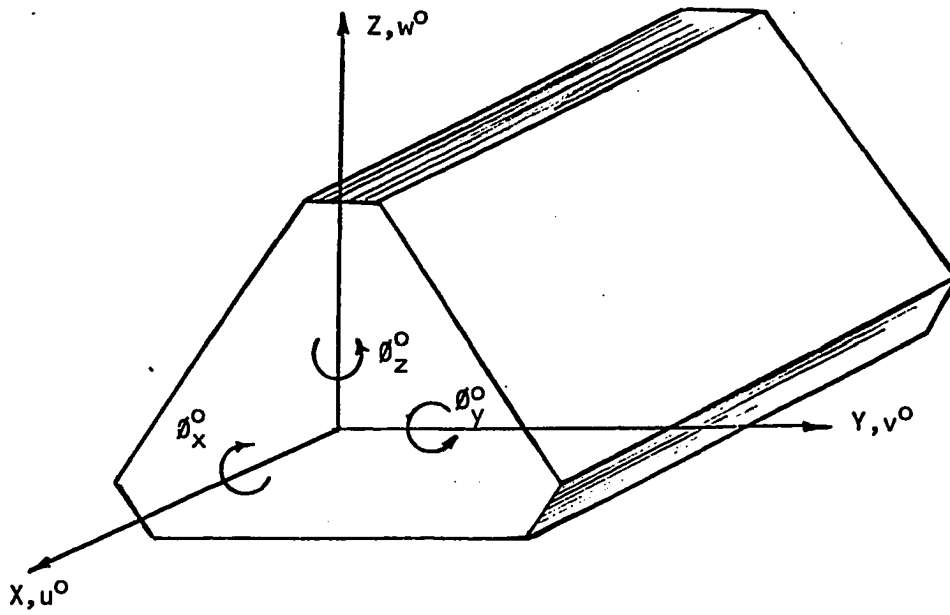

| FORCE | ASSOCIATED DISPLACEMENT |
|-------|-------------------------|
| N | u^0 |
| Q_y | v^0 |
| Q_z | w^0 |
| M_y | θ_y^0 |
| M_z | θ_z^0 |
| T | θ_x^0 |

FIGURE 4.5 - CONTINUUM BEAM MODEL SIGN CONVENTION

$$e_{zz} = \frac{\partial w}{\partial z} = e_z^0 \quad (4.6)$$

$$\begin{aligned} e_{xy} &= \frac{\partial u}{\partial y} + \frac{\partial v}{\partial x} \\ &= \partial v^0 - \theta_z + y \partial e_y^0 + z (\partial e_{yz}^0 - \partial \theta_x) \end{aligned}$$

Therefore;

$$2e_{xy} = 2e_{xy}^0 + y \partial e_y^0 + z \left(\frac{1}{2} \partial (2e_{yz}^0) - k_t^0 \right) \quad (4.7)$$

Similarly;

$$\begin{aligned} e_{xz} &= \frac{\partial u}{\partial z} + \frac{\partial w}{\partial x} \\ &= \theta_y + \partial w^0 + y (\partial \theta_x + \partial e_{yz}^0) + z \partial e_z^0 \end{aligned}$$

Therefore;

$$2e_{xz} = 2e_{xz}^0 + z \partial e_z^0 + y \left(\frac{1}{2} \partial (2e_{yz}^0) + k_t^0 \right) \quad (4.8)$$

Similarly;

$$\begin{aligned} e_{yz} &= \frac{\partial w}{\partial y} + \frac{\partial v}{\partial z} \\ &= 2e_{yz}^0 \end{aligned} \quad (4.9)$$

where e_x^0 is the extensional strain of the centerline of the repeating element;

k_y^0, k_z^0 are the curvature changes in the y and z directions;

k_t^0 is the twist due to torsion about x axis;

$2e_{12}^0$ and $2e_{13}^0$ are the transverse shear strains in the plane of the cross section of the equivalent continuum model.

The nine strain measures ($e_x^0, e_y^0, e_z^0, 2e_{xy}^0, 2e_{xz}^0, 2e_{yz}^0, k_t^0, k_z^0$ and k_t^0) are functions of x only. Therefore, the axial strain in each member

of the repeating element is expressed in terms of the strain components in the coordinate directions as:

$$e^{(k)} = \sum_{i=1}^3 \sum_{j=1}^3 e_{ij}^{(k)} l_i^{(k)} l_j^{(k)} \quad (4.10)$$

Hence, the axial strain in the k^{th} member of the repeating element can be expressed in matrix form as follows:

$$e^{(k)} = [l \quad m \quad n] \begin{bmatrix} e_{xx} & e_{xy} & e_{xz} \\ e_{yx} & e_{yy} & e_{yz} \\ e_{zx} & e_{zy} & e_{zz} \end{bmatrix} \begin{bmatrix} l \\ m \\ n \end{bmatrix} \quad (4.11)$$

where $e^{(k)}$ is the axial strain in the k^{th} member of the repeating element;

$e_{ij}^{(k)}$ are the strain components of the k^{th} member in the coordinate directions evaluated at the centroid of that member;

$l^{(k)}$, $m^{(k)}$, and $n^{(k)}$ are the direction cosines of the k^{th} member.

In order to represent the strain expressions of the discrete system in the continuum model, the strain components in the coordinate directions are expanded in a Taylor series about the centroid of the repeating element. This Taylor series expansion about that point can be expressed as:

$$e_{xx}^{(k)} \approx e_x^0 + y^{(k)} k_y^0 + z^{(k)} k_z^0 + x^{(k)} (\partial e_x^0 - y^{(k)} \partial k_y^0 + z^{(k)} \partial k_z^0) \quad (4.13)$$

$$e_{yy}^{(k)} \approx e_y^0 + x^{(k)} \partial e_y^0 \quad (4.14)$$

$$e_{zz}^{(k)} \approx e_z^0 + x^{(k)} \partial e_z^0 \quad (4.15)$$

$$2e_{xy}^{(k)} \approx 2e_{xy}^0 + \underline{y^{(k)} \partial e_y^0 + z^{(k)} \partial e_{yz}^0} - z^{(k)} \partial k_t^0 + x^{(k)} (\partial(2e_{xy}^0) + \underline{y^{(k)} \partial^2 e_y^0 + z^{(k)} (\partial^2 e_{yz}^0 - \partial k_t^0)}) \quad (4.16)$$

$$2e_{xz}^{(k)} \approx 2e_{xz}^0 + y^{(k)} \partial k_t^0 + \underline{y^{(k)} \partial e_{yz}^0 + z^{(k)} \partial e_z^0} + x^{(k)} (\partial(2e_{xz}^0) + y^{(k)} (\partial k_t^0 + \partial^2 e_{yz}^0) + z^{(k)} \partial^2 e_z^0) \quad (4.17)$$

$$2e_{yz}^{(k)} \approx 2e_{yz}^0 + \underline{x^{(k)} \partial(2e_{yz}^0)} \quad (4.18)$$

where $x^{(k)}$, $y^{(k)}$, and $z^{(k)}$ are the coordinates of the center of the k^{th} member of the repeating element.

To satisfy compatibility between repeating elements of the continuum model, the strain components in the plane of the cross sections of any two adjacent elements (e_{yy} , e_{zz} , and $2e_{yz}$) must be identical at their interface. This is satisfied when the underlined derivatives in Equations (4.13) through Equation (4.18) are set equal to zero. In other words, this can be expressed in mathematical form as:

$$\partial e_y^0 = \partial e_z^0 = \partial(2e_{yz}^0) = 0 \quad (4.19)$$

For lattice structures with single bay double laced repeating element such as the towers shown in Figure 4.1 and Figure 4.2, there are twelve independent modes of deformation that correspond to the zeroth-order terms in Taylor series expansion. On the other hand, there are three compatibility conditions as given by Equation (4.19). Therefore, the total number of strain components used in this Taylor series expansions given by Equations (4.13) through (4.18) reduces to nine components. This is equivalent to assuming a uniform state of strain e_x^0 , k_y^0 , k_z^0 , $2e_{xz}^0$,

$k_t^0, e_y^0, e_z^0, 2e_{yz}^0, 2e_{xy}^0$ within each repeating element.

4.4 Strain Energy and Stiffness Coefficients of Equivalent Continuum Model

Following the development procedures outlined in Chapter II, and as previously discussed in Chapter III, the strain energy of the repeating element can be expressed as follows:

$$U = \frac{1}{2} \sum_{\text{members}} E^{(k)} A^{(k)} L^{(k)} (e^{(k)})^2 \quad (4.20)$$

where $e^{(k)}$ is the axial strain of the k^{th} member of the repeating element;

$E^{(k)}$ is the modulus of elasticity of the k^{th} member of the repeating element;

$A^{(k)}$ is the cross sectional area of the k^{th} member of the repeating element; and

$L^{(k)}$ is the length of the k^{th} member of the repeating element.

When $e^{(k)}$ in Equation (4.20) is replaced by the different strain components as given by Equation (4.10) and Equations (4.13) through (4.18), then the strain energy of the repeating element can be written as a function of the strain gradients as well as the strain components of the equivalent continuum beam model. The strain gradients must be included to obtain correct stiffnesses for more complicated configurations as indicated by Noor and Anderson (11).

As previously mentioned in Chapter III, local deformation should be allowed to occur freely; therefore, the forces associated with these local deformations must be set equal to zero. This can be accomplished by setting the strain energy derivatives with respect to the strain gradients equal to zero. In mathematical form, this can be expressed

as follows:

$$\begin{aligned} \frac{\partial U}{\partial (\partial e_x^0)} &= \frac{\partial U}{\partial (\partial k_y^0)} = \frac{\partial U}{\partial (\partial k_z^0)} = \frac{\partial U}{\partial (\partial (2e_{xy}^0))} = \frac{\partial U}{\partial (\partial (2e_{xz}^0))} = \\ \frac{\partial U}{\partial (\partial k_t^0)} &= \frac{\partial U}{\partial (\partial^2 e_y^0)} = \frac{\partial U}{\partial (\partial^2 e_z^0)} = \frac{\partial U}{\partial (\partial^2 (2e_{yz}^0))} = 0 \quad (4.21) \end{aligned}$$

To reduce the continuum theory as close to an engineering theory, the forces associated with the strain components in the plane of the triangular cross section are set equal to zero. That is,

$$\frac{\partial U}{\partial e_z^0} = \frac{\partial U}{\partial (2e_{yz}^0)} = \frac{\partial U}{\partial e_y^0} = 0 \quad (4.22)$$

Equations (4.21) and (4.22) are used to express the strain gradients and the strain components e_y^0 , e_z^0 , $2e_{yz}^0$ in terms of other strain components; thereby, reducing the strain energy to a quadratic function in the strain components e_x^0 , k_y^0 , k_z^0 , $2e_{xy}^0$, $2e_{xz}^0$, and k_t^0 . The resulting expression of the strain energy can be written as:

$$U = \frac{1}{2} L \{e\}^t [C] \{e\} \quad (4.23)$$

where $\{e\}^t = [e_x^0 \quad k_y^0 \quad k_z^0 \quad 2e_{xy}^0 \quad 2e_{xz}^0 \quad k_t^0]$

L is the length of the repeating element; and

$[C]$ is the six by six matrix of the equivalent stiffness coefficients.

The elements of the equivalent stiffness coefficients were obtained analytically by using MACSYMA symbolic manipulation programming capabilities (14) as discussed in Chapter II. The program used is listed in Appendix C. The equivalent stiffness coefficients listed in Table 4.1 are functions of the geometric and material properties of the

| | |
|-------------------|---|
| C_{11} | $\frac{3}{\lambda} (E_1 A_1 \lambda + 2 \frac{L^3}{D^3} E_d A_d)$ |
| $C_{22} = C_{33}$ | $\frac{B^2}{2\lambda} (E_1 A_1 \lambda + \frac{L^3}{2D^3} E_d A_d)$ |
| $C_{44} = C_{55}$ | $\frac{3 B^2 L}{D^3} E_d A_d$ |
| C_{66} | $\frac{B^4 L}{4D^3} E_d A_d$ |

$$\lambda = 1 + \frac{2B^3}{D^3} \frac{E_d A_d}{E_b A_b}$$

TABLE 4.1- EQUIVALENT STIFFNESS COEFFICIENTS FOR THE TRIANGULAR TOWER WITH CONSTANT CROSS SECTIONS, (11).

repeating element. In this table, the C_{11} coefficient refers to the extensional stiffness of the equivalent continuum model; C_{22} and C_{33} are the bending stiffness coefficients about the y and z axes, respectively; C_{44} and C_{55} are the transverse shear stiffnesses in the plane of the cross section; and C_{66} is the torsional stiffness of the equivalent continuum model about the x axis. In the case of single bay double laced towers with a constant triangular cross section, there are no moment-shear coupling terms between the equivalent stiffness coefficients. This is due to the fact that the Taylor series expansions were taken about the centroid of the repeating section. However, in the case of towers with variable triangular cross sections, the equivalent stiffness coefficients are functions of the geometric and material properties of the repeating element as well as the angle, β , of the sloping legs of the tower. The coefficients for a sloping tower are listed in Table 4.2. Besides the six common stiffnesses which are analogous to those of the ordinary beam shear deformation theory, there are two additional bending-shear coupling terms which appear because of the linear slope of the tower legs and the Taylor series expansion being performed about the mid-height point of the repeating section.

A classical beam theory is obtained from the shear deformation beam theory by setting the transverse shear strains equal to zero. That is,

$$2e_{xy}^0 = \partial v^0 - \theta_z = 0 \quad (4.24)$$

$$2e_{xz}^0 = \partial w^0 + \theta_y = 0 \quad (4.25)$$

This approximation will result in an equivalent beam which does not account for in-plane shearing strains, thus will yield more simplified stiffness coefficients which will fit into classical finite element programs.

EQUIVALENT STIFFNESS COEFFICIENTS FOR THE TRIANGULAR
TOWER WITH VARIABLE CROSS SECTION

| | |
|-------------------|---|
| C_{11} | $27 (2 A_1 A_d E_1 E_d L^4 \cos^3 \beta \tan^4 \beta + 2 A_b A_d E_b E_d B L^3 - 4 A_1 A_d E_1 E_d B^2 L^2 \cos^3 \beta \tan^2 \beta + 2 A_1 A_d E_1 E_d B^4 \cos^3 \beta + A_1 A_b E_1 E_b B D^3 \cos^3 \beta) / (2 A_d E_d L^4 \tan^4 \beta + 12 A_d E_d B^2 L^2 \tan^2 \beta + 16 A_1 E_1 L D^3 \tan^4 \beta + 18 A_d E_d B + 9 A_b E_b D^3)$ |
| C_{22} | $3 (2 A_d^2 E_d^2 L^9 \tan^6 \beta - 4 A_d^2 E_d^2 B^2 L^7 \tan^4 \beta + 16 A_1 A_d E_1 E_d D^3 L^6 \cos^3 \beta \tan^6 \beta + 2 A_d^2 E_d^2 B^4 L^5 \tan^2 \beta + 9 A_b A_d E_b E_d B L^5 D^3 \tan^2 \beta - 20 A_1 A_d E_1 E_d B^2 D^3 L^4 \cos^3 \beta \tan^4 \beta + 3 A_b A_d E_b E_d B^3 L^3 D^3 - 8 A_1 A_d E_1 E_d B^4 L^2 D^3 \cos^3 \beta \tan^2 \beta + 12 A_1 A_d E_1 E_d B^6 D^3 \cos^3 \beta + 6 A_1 A_b E_1 E_b B^3 D^6 \cos^3 \beta) / \{4 D^3 (2 A_d E_d L^4 \tan^4 \beta + 12 A_d E_d B^2 L^2 \tan^2 \beta + 16 A_1 E_1 L D^3 \cos^3 \beta \tan^4 \beta + 18 A_d E_d B^4 + 9 A_b E_b B D^3)\}$ |
| $C_{33} = C_{22}$ | |
| C_{42} | $9 B \tan \beta (A_d^2 E_d^2 L^7 \tan^4 \beta - 2 A_d^2 E_d^2 B^2 L^5 \tan^2 \beta + 2 A_1 A_d E_1 E_d L^4 D^3 \cos^3 \beta \tan^4 \beta + A_d^2 E_d^2 B^4 L^3 + 2 A_b A_d E_b E_d B L^3 D^3 - 4 A_1 A_d E_1 E_d B^2 L^2 D^3 \cos^3 \beta \tan^2 \beta + 2 A_1 A_d E_1 E_d B^4 D^3 \cos^3 \beta + A_1 A_b E_1 E_b B D^6 \cos^3 \beta) / \{D^3 (2 A_d E_d L^4 \tan^4 \beta + 12 A_d E_d B^2 L^2 \tan^2 \beta + 16 A_1 E_1 L D^3 \cos^3 \beta \tan^4 \beta + 18 A_d E_d B^4 + 9 A_b E_b B D^3)\}$ |

| | |
|--------------------|---|
| C_{44} | $ \begin{aligned} & 9 (6 A_d^2 E_d^2 B^2 L^5 \tan^4 \beta + 4 A_1 A_d E_1 E_d D^3 L^4 \cos^3 \beta \tan^6 \beta \\ & - 12 A_d^2 E_d^2 B^4 L^3 \tan^2 \beta + A_b A_d E_b E_d B L^3 D^3 \tan^2 \beta \\ & - 8 A_1 A_d E_1 E_d B^2 D^3 L^2 \cos^3 \beta \tan^4 \beta + 6 A_d^2 E_d^2 B^6 L \\ & + 3 A_b A_d E_b E_d B^3 D^3 L + 4 A_1 A_d E_1 E_d B^4 D^3 \cos^3 \beta \tan^2 \beta \\ & + 2 A_1 A_b E_1 E_b B D^6 \cos^3 \beta \tan^2 \beta) / D^3 (2 A_d E_d L^4 \tan^4 \beta \\ & + 12 A_d E_d B^2 L^2 \tan^2 \beta + 16 A_1 E_1 L D^3 \cos^3 \beta \tan^4 \beta \\ & + 18 A_d E_d B^4 + 9 A_b E_b B D^3) \end{aligned} $ |
| $C_{53} = -C_{42}$ | |
| $C_{55} = C_{44}$ | |
| C_{66} | $A_d E_d L (L \tan^2 \beta - B) (L \tan^2 \beta + B) / 2 D^3$ |

TABLE 4.2 - EQUIVALENT STIFFNESS COEFFICIENTS FOR THE TRIANGULAR TOWER WITH VARIABLE CROSS SECTION

4.5 Kinetic Energy and Mass Coefficients of Equivalent Continuum Model

As previously discussed in Chapter III, in free vibration analysis of lattice structures, it is necessary to compute the equivalent mass matrix for the continuum model using the kinetic energy. Based on the consistent mass approach, the kinetic energy of the repeating element as given by Noor and Anderson (11) can be expressed as follows:

$$T = \frac{1}{6} \omega^2 \sum_{\text{members}} \rho^{(k)} A^{(k)} L^{(k)} (u_i^2 + u_i u_j + u_j^2 + v_j^2 + v_i v_j + v_j^2 + w_i^2 + w_i w_j + w_j^2) \quad (4.26)$$

where $\rho^{(k)}$ is the mass of member k between nodes i and j ;

ω is the natural frequency of vibrations;

$L^{(k)}$ and $A^{(k)}$ are the length and the cross sectional area of the k^{th} member, respectively.

The kinetic energy of the repeating element is obtained in terms of the material and geometric properties of the tower by substituting the expressions for the nodal displacements and rotations given by Equations (4.1) through (4.3), into the following kinetic energy expression (11):

$$T = \frac{1}{2} \omega^2 \sum_{k=1}^n \{d\}^t [\xi^{(k)}]^t [M^{(k)}] [\xi^{(k)}] \{d\} \quad (4.27)$$

where $M^{(k)}$ is the elemental consistent mass matrix of the k^{th} member;

$\{d\}$ is the displacement vector;

$[\xi^{(k)}]$ is the transformation matrix of the k^{th} member of the

$[\xi^{(k)}]$ repeating element as given in Appendix B.

Numerical studies by Noor and Anderson (11) indicate that the inertia terms associated with the strain components e_y^0 , e_z^0 and $2e_{yz}^0$ can be neglected without affecting the natural frequencies of the lower modes.

Therefore, the kinetic energy expression of the equivalent beam model can be expressed in the following form:

$$\begin{aligned}
 T = \frac{1}{2} L \omega^2 [& m_{11} (u^0{}^2 + v^0{}^2 + w^0{}^2) + 2m_{12} (w^0\theta_x - u^0\theta_z) \\
 & + 2m_{13} (u^0\theta_y - v^0\theta_x) - 2m_{23} \theta_y \theta_z + m_{22} (\theta_x^2 + \theta_z^2) \\
 & + m_{33} (\theta_x^2 + \theta_z^2)] \quad (4.28)
 \end{aligned}$$

The final expressions for the mass coefficients of the equivalent beam model for the towers considered are listed in Table 4.3 and Table 4.4, for constant and variable triangular cross sectional towers.

These equivalent mass coefficients are obtained analytically by using MACSYMA symbolic manipulation programming capabilities (14). In Tables (4.3) and (4.4), the coefficient \bar{m}_{11} represents the extensional inertia of the equivalent beam model; whereas, \bar{m}_{22} , \bar{m}_{33} represent the rotary inertia in the plane of the cross section of the equivalent continuum model. There is no coupling between the inertia terms of the equivalent continuum due to the symmetry of the repeating element about its centroidal axis.

4.6 Work Done by External Forces on Three Dimensional Towers

As previously mentioned in Chapter III, the work done by external forces on the equivalent continuum is required in the static analysis. Consistent with the kinematic assumptions given by Equations (4.1) through (4.3), the expression for the work done by external forces can be expressed as follows (11):

$$\begin{aligned}
 \text{Work} = \sum_{i=1}^n [& P_x^i (u^0 - y^i\theta_z + z^i\theta_y) + P_y^i (y^0 + y^i e_y^0 + z^i (e_{yz}^0 - \theta_x)) \\
 & + P_z^i (w^0 + y^i (\theta_x + e_{yz}^0) + y_z^i e_z^0)] \quad (4.29)
 \end{aligned}$$

| | |
|----------------|---|
| \bar{m}_{11} | $3 \rho_1 A_1 + \frac{3B}{L} \rho_b A_b + \frac{6D}{L} \rho_d A_d$ |
| \bar{m}_{22} | $B^2 \left(\frac{1}{2} \rho_1 A_1 + \frac{B}{4L} \rho_b A_b + \frac{D}{2L} \rho_d A_d \right)$ |
| \bar{m}_{33} | $\frac{B^2}{2} \left(\rho_1 A_1 + \frac{B}{2L} \rho_b A_b + \frac{D}{L} \rho_d A_d \right)$ |

TABLE 4.3- EQUIVALENT MASS COEFFICIENTS FOR THE TRIANGULAR TOWER WITH CONSTANT CROSS SECTION, (11)

| | |
|-------------------------------|---|
| \bar{m}_{11} | $\frac{6 \rho_d A_d D}{L} + \frac{3 \rho_b A_b B}{L} + \frac{3 \rho_1 A_1}{\cos \beta}$ |
| $\bar{m}_{22} = \bar{m}_{33}$ | $\frac{5 \rho_d A_d DL \tan^2 \beta}{6} + \frac{1}{2L} \rho_d A_d DB^2 +$ $\frac{1}{4L} \rho_b A_b B^3 + \frac{3}{4} \rho_b A_b BL \tan^2 \beta + \frac{\rho A B^2}{2 \cos \beta}$ $+ \frac{\rho_1 A_1 L^2 \tan^2 \beta}{6 \cos \beta}$ |

TABLE 4.4- EQUIVALENT MASS COEFFICIENTS FOR THE TRIANGULAR TOWER WITH VARIABLE CROSS SECTIONS

where P_x^i , P_y^i , and P_z^i are the external load components at the i^{th} node in the coordinate directions, and the summation extends only over the nodal points where the external forces are applied.

4.7 Evaluation of Member Forces From the Continuum Model Solution of Three Dimensional Towers

As previously discussed in Chapter III, member forces are of prime interest to the designer of tower problems. The following procedures outline the methodology involved in the evaluation of actual member forces of the tower from the equivalent continuum model results. These procedures are similar to the procedures outlined for the planar truss and can be summarized as follows:

1. Substitute the displacements and rotations obtained from the continuum solution for the two nodes connecting the member under consideration into the following displacement relationships.

$$u_i = u_i^0 \pm \bar{z}_i \theta_{xi}^0 \quad (4.30)$$

$$v_i = v_i^0 \pm \bar{z}_i \theta_{yi}^0 \quad (4.31)$$

$$w_i = w_i^0 \pm \bar{z}_i \theta_{zi}^0 \quad (4.32)$$

where u_i , v_i , and w_i are the displacements in the coordinate directions of node i of the repeating section;

(u_i^0, v_i^0, w_i^0) and $(\theta_{xi}^0, \theta_{yi}^0, \theta_{zi}^0)$ are the centerline displacements and rotations of node i of the equivalent continuum in the coordinate direction;

\bar{z}_i is the vertical distance between the centerline of the repeating element of the actual lattice and the i^{th} node.

2. Determine the change in length ΔL_{ij} of member ij connecting node i to node j as follows:

$$\Delta L_{ij} = (u_i - v_j) l + (v_i - v_j) m + (w_i - w_j) n \quad (4.33)$$

where l , m , and n are the direction cosines of member ij of the repeating element in the coordinate directions.

3. Calculate the strain in member ij as follows:

$$e_{ij} = \frac{\Delta L_{ij}}{L_{ij}} \quad (4.34)$$

where L_{ij} is the actual length of member ij .

4. Evaluate the stress σ_{ij} of member ij as:

$$\sigma_{ij} = E_{ij} e_{ij} \quad (4.35)$$

where E_{ij} is the modulus of elasticity of member ij .

5. Determine the force F_{ij} of member ij as follows:

$$F_{ij} = \sigma_{ij} A_{ij} \quad (4.36)$$

where A_{ij} is the cross sectional area of member ij of the repeating element.

4.8 Numerical Studies of Triangular Towers

The objectives of the numerical studies presented in this chapter are to demonstrate the effectiveness of the continuum model solution and to assess the accuracy of the continuum modeling approach in analyzing towers. Static deflection and free vibration comparison are

made between results obtained by the continuum model solution and those obtained by analyzing the actual towers using the classical finite element technique. The results of the free vibration analysis as well as several static analyses for a five bay double laced cantilevered towers as illustrated in Figures 4.1 and 4.2, are presented in this section. Figure 4.6 illustrates the different static loading conditions applied at the free end of the triangular towers considered. In Figure 4.6a, (the case of pure axial loading) a concentrated load of $\frac{N}{3}$ is applied at each node of the free end. This will be equivalent to applying a concentrated axial load equals to N at the free end of the equivalent beam model. The case of transverse shear is illustrated in Figure 4.6b. This type of loading is obtained by applying a concentrated load equals to $\frac{Q_z}{3}$ or $\frac{Q_y}{3}$ in each direction of the triangular cross section at each node of the free end. This is equivalent to applying a concentrated load equals Q_z or Q_y in the plane of the cross section of the equivalent beam model. The twisting moment loading combination as shown in Figure 4.6c is equivalent to applying a torque T in the plane of the cross section of the equivalent beam model. Finally, the bending moment loading condition illustrated in Figure 4.6d is equivalent to applying a moment M_z or M_y about the z or y axes of the equivalent beam model. For simplicity, the material properties of the repeating element is assumed to be constant for all five bays of the towers. As previously discussed in Chapter III, the geometric properties of the end batten members are taken to be one-half those of the interior batten members. A comparison of the results for the axial load case obtained by the equivalent continuum beam model to those obtained by the finite element technique is illustrated in Table 4.5. As shown in this table, the static deflection for the continuum approach is within 1.82 percent of

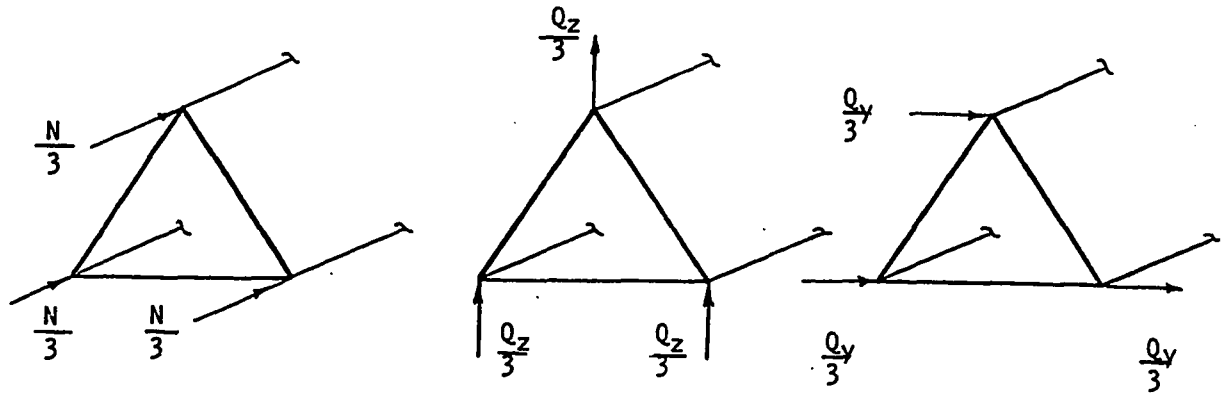

a) AXIAL FORCES

b) TRANSVERSE SHEAR FORCES

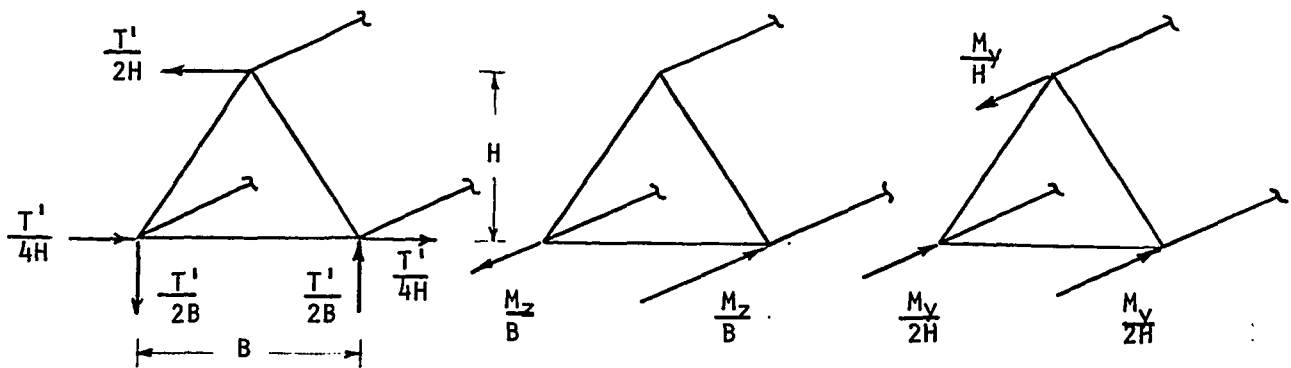

c) TWISTING MOMENT

d) BENDING MOMENT M_y, M_z

FIGURE 4.6 - STATIC LOADING SYSTEMS USED IN THE ANALYSIS OF TOWERS CONSIDERED

| NODE NUMBER | u_{EQ} (FT) | u_{ACT} (FT) |
|-------------|--------------------------|--------------------------|
| 1 | 0.00 | 0.0 |
| 2 | $-.77429 \times 10^{-4}$ | $-.78847 \times 10^{-4}$ |
| 3 | $-.15542 \times 10^{-3}$ | $-.15905 \times 10^{-3}$ |
| 4 | $-.23398 \times 10^{-3}$ | $-.23895 \times 10^{-3}$ |
| 5 | $-.31311 \times 10^{-3}$ | $-.31892 \times 10^{-3}$ |
| 6 | $-.3928 \times 10^{-3}$ | $-.39884 \times 10^{-3}$ |

CPU (SEC)

1.52

2.97

TABLE 4.5 - AXIAL DISPLACEMENTS AND CPU TIME COMPARISON OF THE TOWER SHOWN IN FIGURE 4.1. DUE TO PURE AXIAL LOADING.

the more exact results obtained using the finite element methodology. For the sake of brevity, the results from the other load case are not presented; however, considering all the load cases, the maximum difference between the two solutions was less than 2.5 percent. Using the deformations calculated from the continuum beam model, the forces in certain select members were evaluated according to the procedure outlined in section 4.7. The results, in general, demonstrated an accuracy of less than 0.3 percent error when comparing the two techniques. This error is consistent with the error found in the deflection calculation. It should be noted that this error is not very large for actual design of most civil engineering structures.

Albeit the stress and deflection are a very important criteria in evaluating the performance of this approximate solution, more significant, however, is the computational efficiency of this technique. Specifically, the CPU time for the equivalent continuum model and for the finite element technique was 1.52 seconds and 2.97 seconds, respectively. This represents a 49 percent savings in computer time.

The results from the free vibration analysis of the continuum model as compared to the more exact finite element technique is shown in Table 4.6. Specifically, this table presents the first three natural frequencies in rad/sec for both techniques. As can be seen, the two results are in excellent agreement. Specifically, the maximum difference is less than 0.1 percent. Figure 4.7 illustrates the ratio of the natural frequencies for the first two extensional, bending, and torsional modes. Here, as was in the case of planar truss, it appears that the continuum model represents the energies in the lower modes better than in the higher modes (error in frequencies increase in the higher modes). In addition, it is noteworthy that the error difference in the bending modes is less

| MODE NUMBER | ω_{EQ} RAD/SEC | ω_{ACT} RAD/SEC |
|-------------|-----------------------|------------------------|
| 1 | 0.1176×10^3 | 0.1165×10^3 |
| 2 | 0.1183×10^3 | 0.1172×10^3 |
| 3 | 0.1854×10^3 | 0.1846×10^3 |

CPU (SEC) 1.53 4.04

TABLE 4.6 - NATURAL FREQUENCIES OF VIBRATIONS AND CPU TIME COMPARISON OF THE TOWER SHOWN IN FIGURE 4.1

$E(i) = i^{\text{th}}$ EXTENSIONAL MODE

$B(i) = i^{\text{th}}$ BENDING MODE

$T(i) = i^{\text{th}}$ TORSIONAL MODE

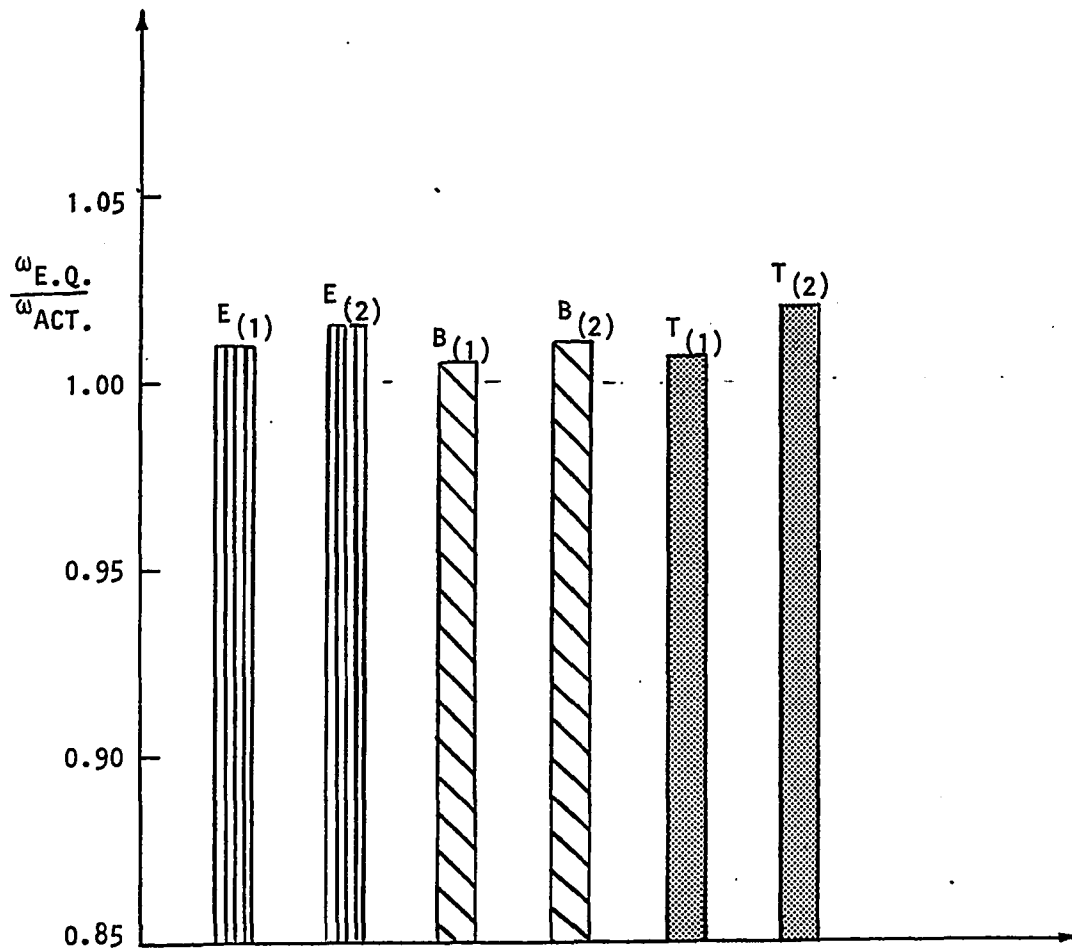

FIGURE 4.7 - BAR GRAPH DISPLAYING COMPARATIVE ACCURACY OF LOW VIBRATION FREQUENCIES OBTAINED BY EQUIVALENT CONTINUUM FOR CANTILEVERED TRIANGULAR TOWER WITH CONSTANT CROSS SECTION.

than the extensional or torsional mode. It would appear that the continuum model may represent the bending or flexure energy better than the other types of energies. Figure 4.8 depicts the shapes for the first three modes. The results of both technique agreed quite closely.

As in the static analyses, there was a significant computational savings in computer time using the continuum modeling technique. Specifically, the CPU time for the equivalent model approach was 1.53 seconds; whereas, for the finite element technique, the CPU time was 4.04 seconds. This represents a saving of approximately 63 percent.

Similar analyses on a five bay double laced tower with variable triangular cross (see Figure 4.2) produced similar results and conclusions as those of the previously described tower. Results of the static load cases indicate very good agreement between the continuum modeling technique and the finite element technique. The maximum difference between any of the load case was less than 3.2 percent. The results of the free vibration analysis (illustrated in Table 4.7) indicated a 0.12 percent difference in the fundamental natural frequency and less than 0.5 percent for the other two frequencies. Figure 4.9 depicts the ratio of the natural frequencies calculated by the continuum model to those calculated by the finite element technique. As in previous results, the bending mode appears to give better results than the other two modes.

In the case of the free vibration analysis of this tower, significant computer time was saved when comparing the continuum modeling technique to the classical finite element methodology. Specifically, the CPU time for the continuum model approach was 1.58 seconds and for the finite element technique, the CPU time was 4.13 seconds. This represents an approximate saving of 62 percent in computer time.

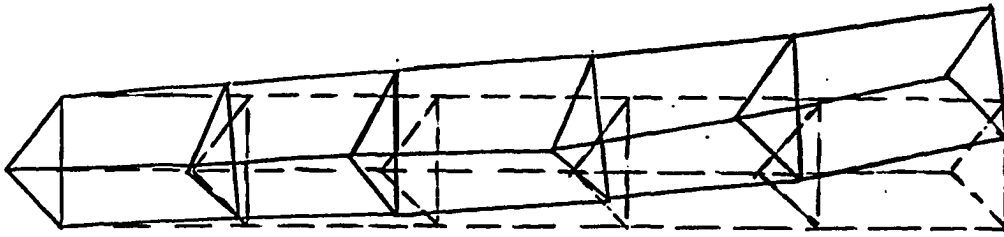

$$\omega_{(1)EQ} = 18.717 \text{ HZ}$$

$$\omega_{(1)ACT.} = 18.542 \text{ HZ}$$

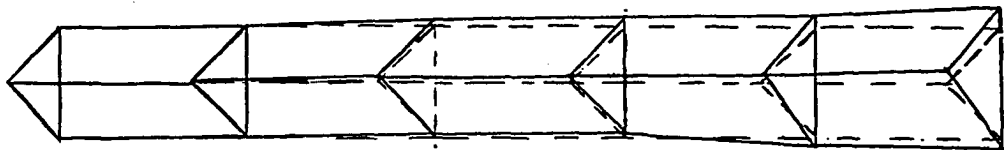

$$\omega_{(2)EQ} = 18.828 \text{ HZ}$$

$$\omega_{(2)ACT.} = 18.656 \text{ HZ}$$

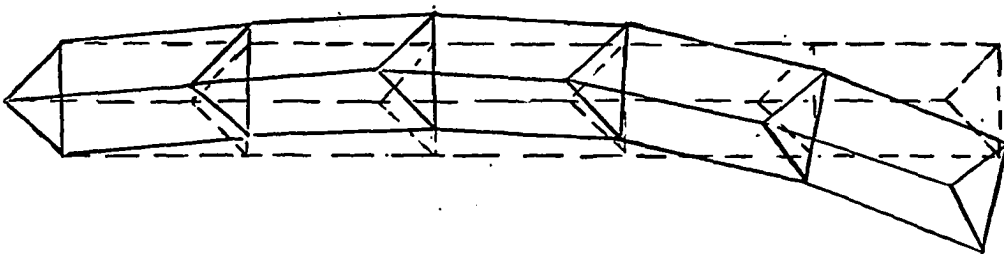

$$\omega_{(3)EQ} = 29.507 \text{ HZ}$$

$$\omega_{(3)ACT.} = 29.380 \text{ HZ}$$

FIGURE 4.8 - VIBRATION MODE SHAPES FOR THE CANTILEVERED TRIANGULAR TOWER WITH CONSTANT CROSS SECTION.

| MODE NUMBER | ω_{EQ} RAD/SEC | ω_{ACT} RAD/SEC |
|-------------|-----------------------|------------------------|
| 1 | $.1619 \times 10^3$ | 0.1617×10^3 |
| 2 | $.1625 \times 10^3$ | 0.1620×10^3 |
| 3 | $.2349 \times 10^3$ | 0.2339×10^3 |
| 4 | $.3852 \times 10^3$ | 0.3843×10^3 |

CPU (SEC) 1.58 4.13

TABLE 4.7 - NATURAL FREQUENCIES OF VIBRATIONS AND CPU TIME FOR THE TOWER SHOWN IN FIGURE 4.2

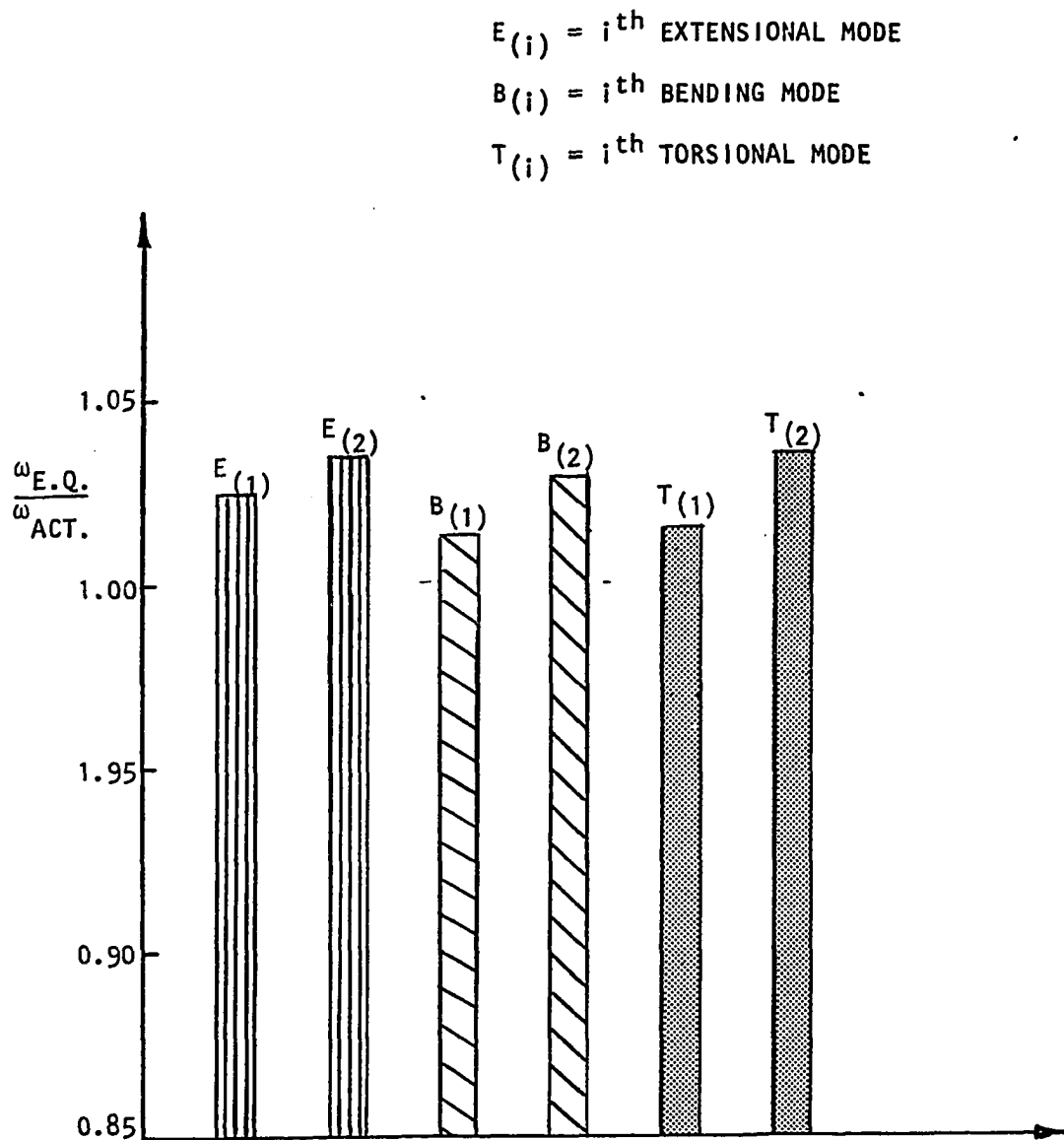

FIGURE 4.9 - BAR GRAPH DISPLAYING COMPARATIVE ACCURACY OF LOW VIBRATION FREQUENCIES OBTAINED BY THE EQUIVALENT CONTINUUM MODEL FOR THE CANTILEVERED TOWER WITH VARIABLE TRIANGULAR CROSS SECTIONS

In summary, this chapter has clearly demonstrated the accuracy of the continuum modeling technique in the analyses of both the constant cross-section and variable cross-section three dimensional towers. In addition to the accuracy being well within tolerable limits for design, the continuum modeling technique has exhibited significant computer savings. This savings coupled with the potential man-hours saved in preparing input data make the continuum modeling technique a very attractive analytical tool for design purposes.

CHAPTER V
APPLICATIONS TO TOWERS WITH RECTANGULAR
CROSS SECTIONS

5.1 General Remarks

Recent development in the construction and fabrication of large repetitive rectangular towers has stimulated interest in the use of approximate techniques for analyzing these types of structures. The continuum model approach provides a practical and effective method for predicting the response and comparing the stiffnesses of towers and lattices with different geometric and material properties. The purpose of this chapter is to apply and attempt to model the equivalent properties of rectangular cross sectional towers in a classical finite element program (12).

The major difference in the development of the equivalent continuum model for towers with rectangular cross sections and those with triangular cross sections as discussed in Chapter IV is the inclusion of the effect of warping and shear deformation in the plane of the rectangular cross sections. Therefore, the equivalent continuum theory presented in Chapter IV must be modified to account for this warping and shear deformation in the plane of the cross section as indicated by Noor (15).

5.2 Kinematic Assumptions

For the rectangular cross sectional tower illustrated in Figure 5.1, the deformed position of a cross section is completely specified by twelve displacement parameters. In other words, three displacement components are specified at each corner node. Each displacement component is assumed to have a linear variation along the pin-connected members of the repeating element, and a bilinear variation in the (Y - Z) plane of the cross section. Hence, an accurate representation

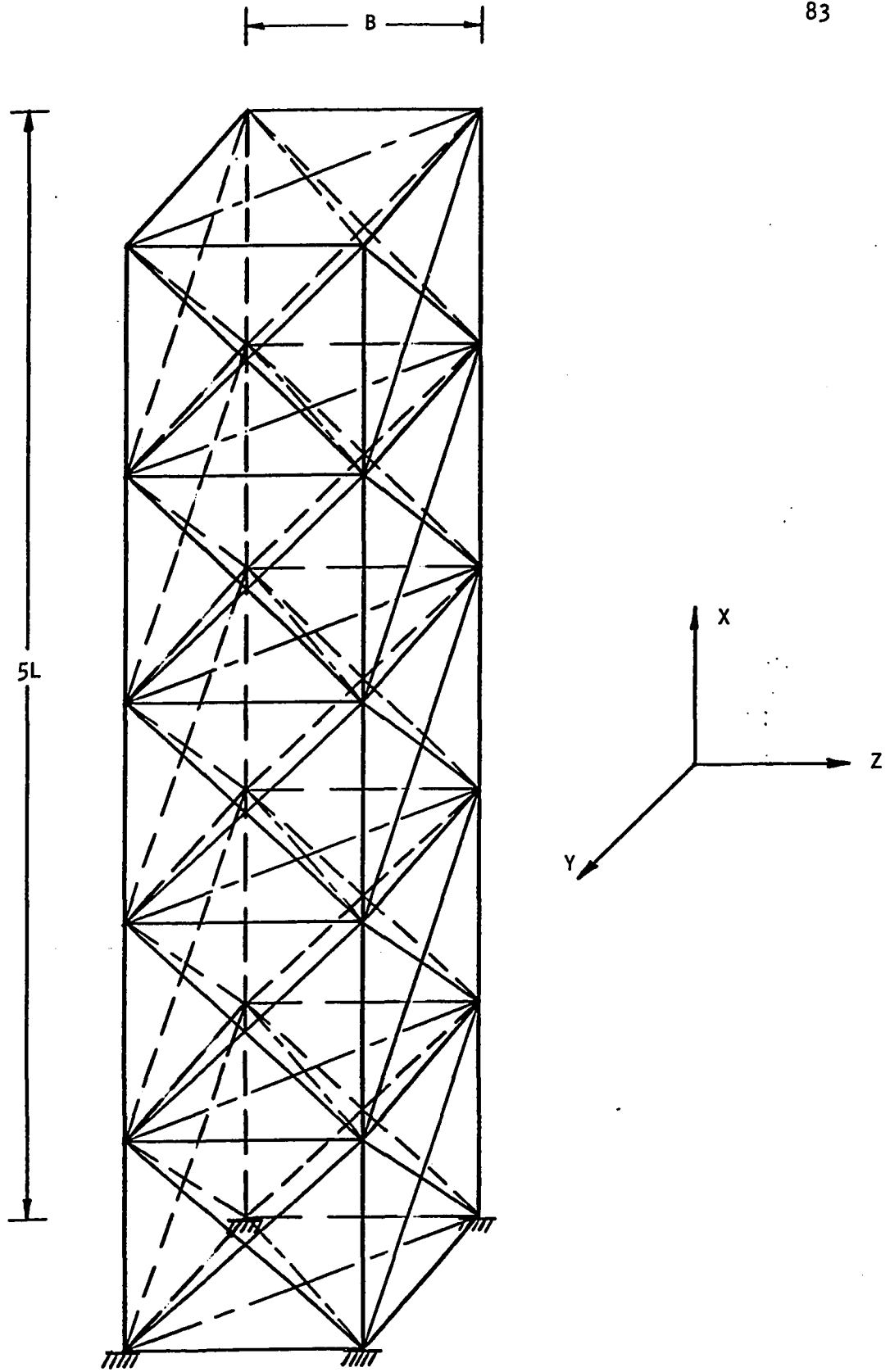

FIGURE 5.1 - FIVE-BAY DOUBLE LACED TOWER WITH CONSTANT RECTANGULAR CROSS SECTION

(15) of the displacement field in the plane of the cross section can be expressed as:

$$u = u^0 - y\theta_y + yz\bar{u} \quad (5.1)$$

$$v = v^0 + y e_y^0 + z (e_{yz}^0 - \theta_x) + yz\bar{v} \quad (5.2)$$

$$w = w^0 + y (e_{yz}^0 + \theta_x) + z e_z^0 + yz\bar{w} \quad (5.3)$$

where u^0 , v^0 , w^0 are the displacement components at $y = z = 0$;

θ_x , θ_y , θ_z are the rotational components;

e_y^0 , e_z^0 are the extensional strains in the plane of the cross section;

e_{yz}^0 is half the shearing strain in the $y - z$ plane;

\bar{u} , \bar{v} , \bar{w} are warping and distortion parameters of the cross section about x , y , and z axes, respectively.

The twelve parameters (namely u^0 , v^0 , w^0 , θ_x , θ_y , θ_z , e_y^0 , e_z^0 , e_{yz}^0 , \bar{u} , \bar{v} and \bar{w}) are functions of the axial coordinate x only. The repeating element of the rectangular tower considered is depicted in Figure 5.2 along with the associated sign convention. The equivalent continuum beam model and its sign convention is shown in Figure 5.3.

Based on the kinematic hypothesis given by Equation (5.1) through Equation (5.3), the strain components have a bilinear variation in the plane of the cross section as follows (15):

$$e_x = e_x^0 - yk_y^0 + zk_z^0 + yz\theta^0 \quad (5.4)$$

$$e_y = e_y^0 + z\bar{v} \quad (5.5)$$

$$e_z = e_z^0 + y\bar{w} \quad (5.6)$$

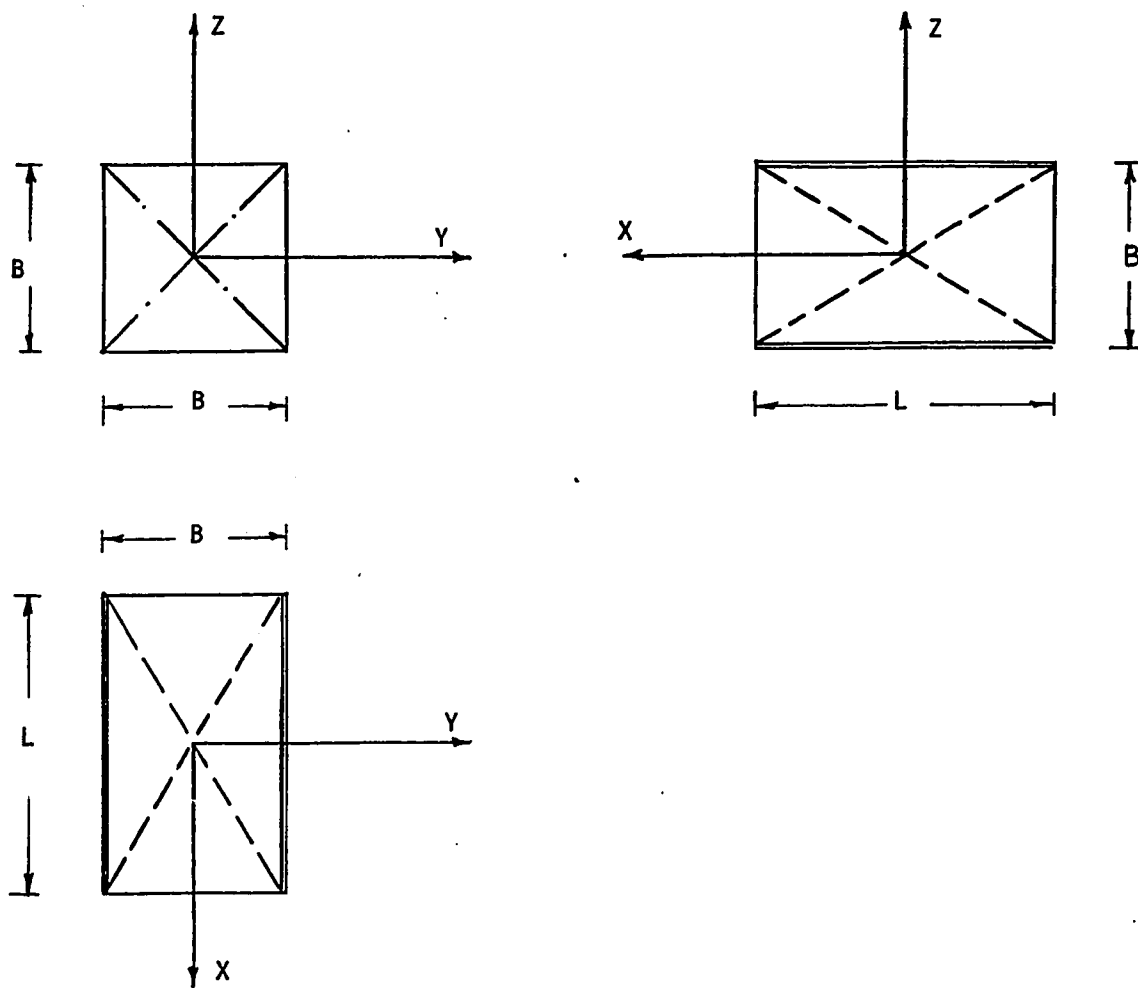

| MEMBERS | CROSS SEC. AREA | MOMENT OF INERTIA | MASS DENSITY | MEMBER LENGTH | DESIGNATION |
|-----------------|-----------------|-------------------|--------------|---------------|-------------|
| LONGITUDINAL | A_l | I_l | ρ_l | L | ==== |
| BATTEN | A_b | I_b | ρ_b | B | _____ |
| DIAGONAL | A_d | I_d | ρ_d | D | ----- |
| BATTEN DIAGONAL | A_{l1} | I_{l1} | ρ_{l1} | D_1 | - . - . - |

FIGURE 5.2 - REPEATING ELEMENT OF DOUBLE LACED RECTANGULAR TOWER WITH CONSTANT CROSS SECTION

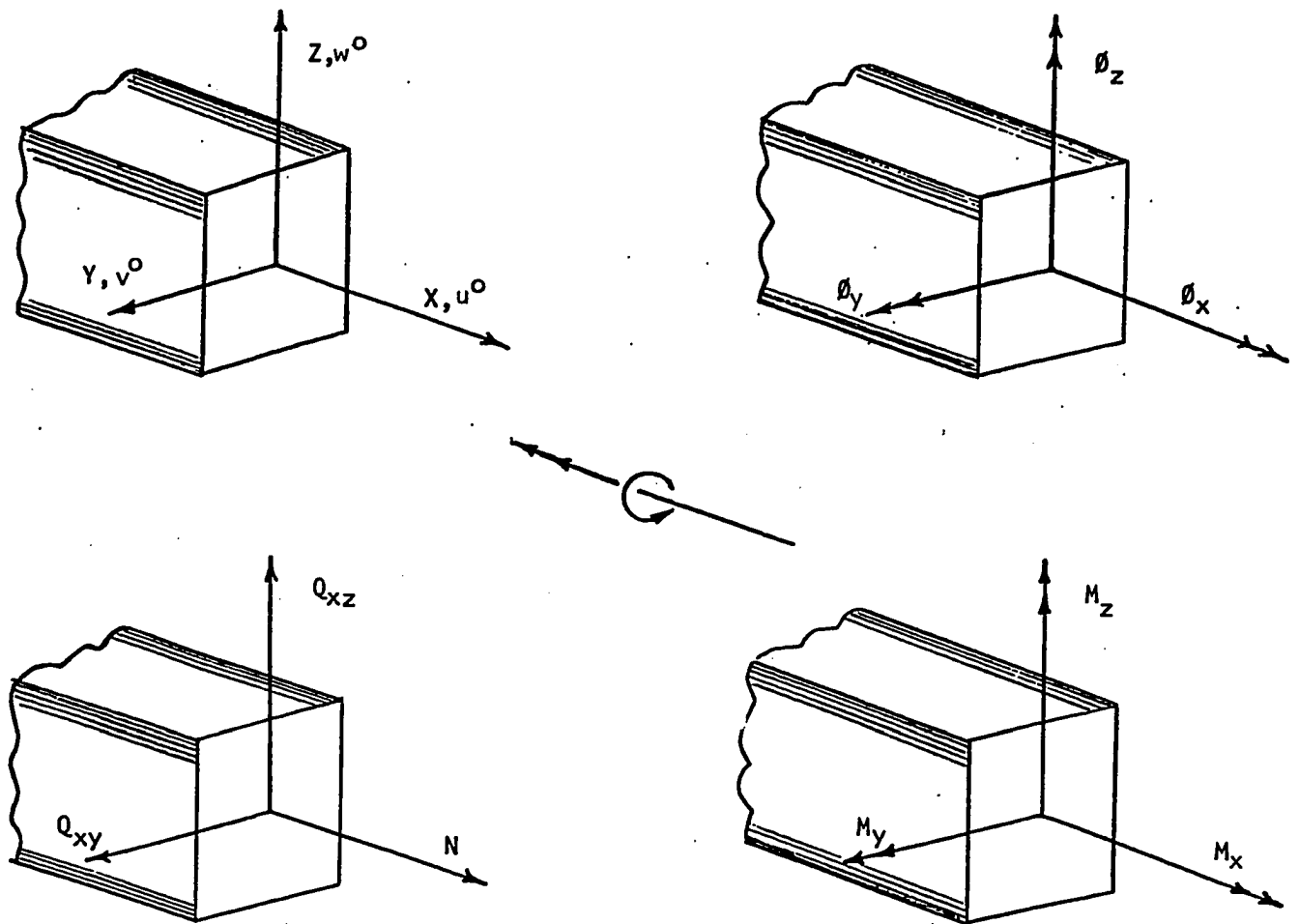

FIGURE 5.3 EQUIVALENT CONTINUUM SIGN CONVENTION FOR THE TOWER SHOWN IN FIGURE 5.1

$$2e_{xy} = 2e_{xy}^0 + y\partial e_y^0 + z(\bar{k} - k_t^0) + yz\partial\bar{v} \quad (5.7)$$

$$2e_{xz} = 2e_{xz}^0 + y(\bar{k} + k_t^0) + z\partial e_z^0 + yz\partial\bar{w} \quad (5.8)$$

$$2e_{yz} = 2e_{yz}^0 + y\bar{v} + z\bar{w} \quad (5.9)$$

where $e_x^0 = \partial u^0$ is the extensional strain of the centerline;

$k_y^0 = \partial\theta^0$ is the curvature change in the y - direction;

$k_z^0 = \partial\theta_y$ is the curvature change in the z - direction;

$k_t^0 = \partial\theta_x$ is the twist about the x - direction;

$2e_{xy}^0 = (\partial v^0 - \theta_3)$ is the transverse shear strain in the x-y plane;

$2e_{xz}^0 = (\partial w^0 + \theta_2)$ is the transverse shear strain in the x-z plane;

$\theta^0 = \partial\bar{u}$ and $\bar{k} = \partial e_{yz}^0$ are strain parameters due to the warping of the cross section.

The strain measures namely e^0 , k_y^0 , k_z^0 , e_{xz}^0 , e_{xy}^0 , k_t^0 , θ^0 and \bar{k} are assumed to be only a function of the axial deformation of the longitudinal axis of the tower. As previously discussed, the axial strain in each member of the repeating element is replaced by its expression in terms of the strain components in the coordinate direction as given by Equation (4.10). The strain components in the coordinate directions are expanded in a Taylor series about the centroid of the repeating element to conduct the transformation from the discrete structure to the equivalent continuum. Using Equations (5.4) through (5.9) and retaining the first two terms of Taylor series, the following approximation for the strains are obtained by Noor and Anderson (15) as:

$$\begin{aligned}
e_x^{(k)} \approx & e_x^o - y^{(k)} k_y^o + z^{(k)} k_z^o + y^{(k)} z^{(k)} \theta^o \\
& + x^{(k)} (\partial e_x^o - y^{(k)} \partial k_y^o + z^{(k)} \partial k_z^o + y^{(k)} (\\
& z^{(k)} \partial \theta^o)) \quad (5.10)
\end{aligned}$$

$$e_y^{(k)} \approx e_y^o + z^{(k)} \bar{v} + x^{(k)} (\partial e_y^o + z^{(k)} \partial \bar{v}) \quad (5.11)$$

$$e_z^{(k)} \approx e_z^o + y^{(k)} \bar{w} + x^{(k)} (\partial e_z^o + y^{(k)} \partial \bar{w}) \quad (5.12)$$

$$\begin{aligned}
2e_{xy}^{(k)} \approx & 2e_{xy}^o + y^{(k)} \partial e_y^o + z^{(k)} (\bar{k} - k_t^o) + y^{(k)} (\\
& z^{(k)} \partial \bar{v}) + x^{(k)} \partial (2e_{xy}^o) + y^{(k)} \partial^2 e_z^o + z^{(k)} \\
& (\partial \bar{k} - \partial k_t^o) + y^{(k)} z^{(k)} \partial^2 \bar{v} \quad (5.13)
\end{aligned}$$

$$\begin{aligned}
2e_{xz}^{(k)} \approx & 2e_{xz}^o + y^{(k)} (k_t^o + \bar{k}) + z^{(k)} \partial e_z^o + y^{(k)} (\\
& z^{(k)} \partial \bar{w}) + x^{(k)} \partial (2e_{xz}^o) + y^{(k)} (\partial \bar{k} + \partial k_t^o) \\
& + z^{(k)} \partial^2 e_z^o + y^{(k)} z^{(k)} \partial^2 \bar{w} \quad (5.14)
\end{aligned}$$

$$\begin{aligned}
2e_{yz}^{(k)} \approx & 2e_{yz}^o + y^{(k)} \bar{v} + z^{(k)} \bar{w} + x^{(k)} (y^{(k)} \partial \bar{v} \\
& + \partial (2e_{yz}^o) + z^{(k)} \partial \bar{w}) \quad (5.15)
\end{aligned}$$

where $w^{(k)}$, $y^{(k)}$, $z^{(k)}$ are the coordinates of the center of the k^{th} member of the repeating element;

$\partial = \frac{\partial}{\partial x}$; and $\partial^2 = \frac{\partial^2}{\partial x^2}$ are partial derivatives with respect to x .

To satisfy the compatibility requirements between repeating elements of the continuum model, the two strain components e_y and e_z in the plane of the cross section at the interface of any two adjacent elements have to be identical. This condition is satisfied if the odd-order derivatives of these strain components are set equal to zero as

follows:

$$\partial e_y^0 = \partial e_z^0 = \partial \bar{v} = \partial \bar{w} = 0 \quad (5.16)$$

5.3 Strain Energy and Stiffness Coefficients of the Equivalent Continuum Model

The strain energy of the repeating element of the rectangular tower is given by Equation (4.20). If $e^{(k)}$ in Equation (4.20) is replaced by its expressions in terms of the strain expansions given by Equations (5.10) through (5.15), the strain energy of the repeating element can be expressed as a quadratic function of the strain components and strain gradients (refer to Equation 4.23).

The strain gradients account for the local deformation which must occur freely within the repeating element. Therefore, they should be included to obtain correct stiffness for complicated latticed configurations (15). Hence, to allow for these local deformations to occur, the forces associated with them should be equal to zero. The derivatives of the strain energy expressions with respect to these strain gradients must be set equal to zero that is:

$$\begin{aligned} \frac{\partial U}{\partial (\partial e_x^0)} &= \frac{\partial U}{\partial (\partial k_y^0)} = \frac{\partial U}{\partial (\partial k_z^0)} = \frac{\partial U}{\partial \partial (2e_{xy}^0)} = \frac{\partial U}{\partial \partial (2e_{xz}^0)} \\ &= \frac{\partial U}{\partial (\partial k_t^0)} = \frac{\partial U}{\partial (\partial \theta^0)} = \frac{\partial U}{\partial (\partial \bar{k})} = \frac{\partial U}{\partial (\partial^2 e_y^0)} \\ &= \frac{\partial U}{\partial (\partial^2 e_z^0)} = \frac{\partial U}{\partial (\partial^2 \bar{v})} = \frac{\partial U}{\partial (\partial^2 \bar{w})} = 0 \quad (5.17) \end{aligned}$$

Moreover, in order to obtain an engineering beam theory similar to the thin-walled beam theory which does not account for shear

deformation in the plane of the cross section, the forces associated with the strain components e_y^0 , e_z^0 , \bar{v} and \bar{w} are set equal to zero that is:

$$\frac{\partial U}{\partial e_y^0} = \frac{\partial U}{\partial e_z^0} = \frac{\partial U}{\partial \bar{v}} = \frac{\partial U}{\partial \bar{w}} = 0 \quad (5.18)$$

In general, the forces associated with the remaining strain parameters cannot be neglected in order to obtain accurate results. In addition, the inclusion of the two strain parameters namely \bar{k} and $2e_{yz}^0$ is necessary to obtain correct warping response of towers with rectangular cross sections especially those with unstiffened batten members.

Equations (5.17) and (5.18) can be used to express the strain gradient as well as the strain components e_y^0 , e_z^0 , \bar{v} and \bar{w} in terms of the other strain components, and thereby reduces the strain energy to a quadratic form in the nine strain components (namely e_x^0 , k_y^0 , k_z^0 , $2e_{xy}^0$, $2e_{xz}^0$, k_t^0 , θ^0 , \bar{k} and $2e_{yz}^0$). The equivalent stiffness coefficients C_{ij} as given by Equation (3.16) are obtained by the aid of MACSYMA computerized symbolic program (15), and the corresponding equivalent stiffness expressions for the tower shown in Figure 5.1 are given in Table 5.1. These coefficients agreed with those obtained by Noor and Anderson (15).

5.4 Kinetic Energy and Mass Coefficients of the Equivalent Continuum Model

The kinetic energy of the repeating element when the consistent mass approach is used is given by Equation (4.26). However, when the constitutive relationships given by Equations (5.1) through (5.3) are used and the inertia terms associated with the strain components e_y^0 , e_z^0 , \bar{v} and \bar{w} are neglected, the kinetic energy of the equivalent continuum model for the rectangular tower shown in Figure (5.1) can be expressed

| | |
|-----------------|---|
| C_{11} | $4E_1 A_1 + \frac{8}{Q} \frac{L^3}{D^3} E_d A_d$ |
| $C_{22}=C_{33}$ | $B^2 (E_1 A_1 + \frac{1}{Q_1} \frac{L^3}{D^3} E_d A_d)$ |
| $C_{44}=C_{55}$ | $\frac{4 B^2 L}{D^3} E_d A_d$ |
| C_{66} | $\frac{2 B^4 L}{D^3} E_d A_d$ |
| C_{77} | $\frac{B^4}{4} E_1 A_1$ |
| C_{88} | $\frac{2 B^4 L}{D^3} E_d A_d$ |
| C_{99} | $\frac{1}{\sqrt{2}} \frac{B}{L} E_1 A_1$ |

where

$$Q = 1 + \frac{2B^3 E_d A_d}{D^3 E_b A_b} \left(1 + \frac{E_1 A_1}{E_b A_b \sqrt{2}}\right)^{-1}$$

$$Q_1 = 1 + \frac{2B^3 E_d A_d}{D^3 E_b A_b}$$

TABLE 5.1- EQUIVALENT STIFFNESS COEFFICIENTS FOR THE CONTINUUM MODEL OF THE RECTANGULAR TOWER SHOWN IN FIGURE 5.1, (15)

as:

$$\begin{aligned}
 T = \frac{1}{2} L \omega^2 [& m_{11} (u^0)^2 + (v^0)^2 + (w^0)^2 + (m_{22} + m_{33}) \\
 & \theta_x^2 + (e_{yz}^0)^2 + \theta_x (m_{22} + m_{33}) (2e_{yz}^0) + m_{22} \theta_z^2 \\
 & + m_{33} \theta_y^2 + m_{2233} \bar{u}^2] \quad (5.19)
 \end{aligned}$$

where L is the length of the repeating element;

ω is the circular frequency of vibration of the equivalent continuum model;

m_{11} is the extensional inertia;

m_{22} and m_{33} are mass rotary inertia about y and z axes, respective, and

m_{2233} is the mass density parameter for warping - shear modes.

The equivalent mass coefficients given by Equation (3.24) were obtained by using MACSYMA computerized symbolic program (15). However, the equivalent continuum mass coefficients of the rectangular tower shown in Figure 5.1 are given in Table 5.2.

5.5 General Discussions and Findings

The continuum approach presented herein to predict the static and free vibration responses of large repetitive towers with rectangular cross sections is based on replacing the original lattice structure by an equivalent continuum beam model which accounts for warping and shear deformation in the plane of the cross section. This warping effect occurs because the rectangular tower cross section does not remain plane during deformation. The equivalent elastic material and geometric properties of towers with constant rectangular cross section were obtained and these coefficients are listed in Table 5.1 and Table 5.2.

| | |
|-----------------|--|
| m_{11} | $4 \left[\rho_1 A_1 + \frac{B}{L} (\rho_b A_b + \frac{1}{\sqrt{2}} \rho_1 A_1) + \frac{2D}{L} \rho_d A_d \right]$ |
| $m_{22}=m_{33}$ | $B^2 \left[\rho_1 A_1 + \frac{2B}{3L} (\rho_b A_b + \frac{1}{2\sqrt{2}} \rho_1 A_1) + \frac{4D}{3L} \rho_d A_d \right]$ |
| m_{2233} | $\frac{B^4}{4} \left[\rho_1 A_1 + \frac{B}{3L} (\rho_b A_b + \frac{3}{\sqrt{2}} \rho_1 A_1) + \frac{2D}{3L} \rho_d A_d \right]$ |

TABLE 5.2 - EQUIVALENT MASS COEFFICIENTS FOR THE CONTINUUM MODEL OF THE RECTANGULAR TOWER SHOWN IN FIGURE 5.1, (15)

An attempt to develop the equivalent elastic properties of rectangular towers with sloping legs was made, but the expressions for the equivalent stiffness coefficients were extremely long and coupling terms appeared which made the modeling of such problem extremely complicated and impractical from the engineering design point of view. Moreover, even for the rectangular towers with constant cross section, results of numerical studies conducted herein indicated that it is impossible to accurately model the equivalent continuum in most classical finite element programs or even SAP IV, the program used in the present study. However, Noor and Anderson (15) have conducted some numerical studies and compared the closed form solution of the equivalent beam model with exact solution based on direct analysis of the actual lattice structure. The numerical studies indicated some difference in the first six distinct frequencies obtained by the reduced theory in which the transverse shear strains $2e_{xy}^0$, $2e_{xz}^0$ and the strain parameter \bar{k} are set equal to zero. A difference of 15% was indicated between the two solutions for a ten bay single-bay-double laced beam, and this difference reduced to 4% when the number of repeating elements increased to twenty bays. It is found that the reduced theory over estimates the bending frequencies, and it also over estimates the warping-shear frequencies due to neglecting of \bar{k} and m_{2233} . It was found that the first two fundamental modes are warping-shear modes. Therefore, it is necessary to include the effect of the warping and shear deformation in the plane of the cross section in order to predict these warping-shear modes and obtain accurate results.

CHAPTER VI

CONCLUSIONS AND RECOMMENDATIONS

6.1 Summary

For economical reasons, large towers and complex space lattice structures are usually designed such that individual elements are joined in a regular geometrical pattern. This regularity renders the system tractable for rational field analysis. However, the application of these rational field techniques for discrete systems remains as a relatively undeveloped field to this date while the closed-form analysis of the analogous continuous systems, a much narrower class of problems, is quite well developed. This study applies the continuum modeling methodology as a rational approach for analyzing repetitive types of structures.

The equivalent continuum models applied in this study have demonstrated the versatility and the flexibility of the equivalent energy approach for determining the continuum properties of the repeating element of repetitive truss structures. The equivalent energy approach is based on equating the strain and kinetic energies in the repeating element of the actual structure to those energies of the continuum model. The strain and kinetic energies of the equivalent continuum are obtained by making displacement or strain assumptions, then calculating the strain and kinetic energies of the repeating element in terms of the displacement or strain parameters as well as geometric and material properties of the latticed structure. The key step to obtaining accurate equivalent coefficients is the selection of the appropriate kinematic hypothesis which includes all possible deformation modes of the repeating element. In addition, the total number of displacement

parameters in the repeating element provides an upper bound on the number of terms that should be retained in Taylor series expansions which relate the displacements or strains in the discrete system to those of the equivalent continuum model.

The accuracy and the effectiveness of the continuum models applied in the present study for analyzing civil engineering problems under different static loading conditions as well as predicting the free vibration response have been demonstrated by numerical examples. The equivalent continuum models for towers of constant and variable triangular cross sections have been developed. In addition, the development of general procedures to obtain the member forces of the actual latticed structure from the equivalent continuum results is presented. Moreover, a computer time comparison between the equivalent continuum solution and the actual structure solution using finite element program SAP IV, for the planar truss and three dimensional towers is presented.

6.2 Conclusions

From the present study, the following conclusions are drawn:

1. The numerical studies have demonstrated the accuracy of the solution obtained by the continuum model for repetitive structures even when the number of repeating elements is low. For example, analysis of a planar truss indicated less than 1% difference in the static deflections and member forces between the two solutions. The free vibration analysis of a planar truss also indicated less than 1.5% difference for the lower fundamental frequency. In the case of towers with constant and variable triangular cross sections, the results indicate approximately 2% difference

in static deflections, 0.3% difference in the member forces, .95% difference in the fundamental vibration frequency and less than 4% difference between the two solutions for higher vibration modes.

2. Rotary inertia was found to have a small effect on the lower vibration frequencies of the continuum model for towers.
3. Bending-shear coupling terms C_{42} and C_{53} of the equivalent stiffness coefficients for the triangular tower with variable cross sections can be neglected without significant effect on the accuracy of the response.
4. Simulating the equivalent continuum properties by a shear deformation beam model referred to as engineering beam model was found to be adequate for predicting the static deflections and the lower natural frequencies of pin jointed latticed structures.
5. Warping-shear deformation of towers with rectangular cross section has a significant effect on their static and dynamic responses. Therefore, the shear-warping parameters and their effects must be considered in the analysis for accurate responses. This cannot be done using the standard beam element of a classical finite element program as was found from this study.
6. The savings in computational cost and computer time by using continuum models is significant (49% for the static analysis and approximately 62% for the dynamic analysis of the five bay triangular tower considered).

6.3 Recommendation for Future Studies

The equivalent continuum modeling approach is a very attractive design tool to the professional engineer. Hence, the equivalent energy approach for determining the equivalent properties of repetitive latticed structures appears to offer considerable potential for future development. As there is a limitless variety of latticed structures with different shapes and boundary conditions, the subject of future studies is extreme, broad and limited only by the imagination of the investigator or the designer. The following are some suggestions and aspects of continuum modeling that deserve further attention:

1. Complete studies to identify the sensitivities of static, free vibration and forced vibration responses to variations in material and geometric properties of the repetitive lattice structures.
2. Development and improvement of the continuum theory to study the effect of joint eccentricities and member imperfections on the response characteristics of towers and other lattice structures.
3. Development of modeling techniques to count for geometric and material nonlinearities in lattice structures.
4. Development of broad techniques for transforming models and solutions along with member design from one lattice connectivity pattern to another of similar shape.

REFERENCES

1. Bibliography on Latticed Structures. Journal of the Structural Division, ASCE, Vol. 98, No. St7, July 1972.
2. Przemienicki, J. S., Theory of Matrix Structural Analysis, McGraw Hill Book Company, 1968.
3. Noor, A. K. and Voigt, S. T. "Hyper Matrix Scheme for Finite Element Systems on CDC STAR-100 Computer", Computers and Structures, Vol. 5, 1975, pp. 287 - 196.
4. Dean, D. L. and Avent, R. R., "State of the Art of Discrete Field and Analysis of Space Structures", Proceedings of the Second International Conference on Space Structures, University of Surrey, Guildford, England, Sept. 1975, pp. 7-16.
5. Dean, D. L. "On Techniques of Discrete Field Mechanics" ASCE Engineering Mechanics Division Speciality Conference on Discrete and Continuum Concepts in Micro and Macro Mechanics. Volume of summary papers North Carolina State University, Raleigh, N. C., Nov. 1967.
6. Renton, J. D. "Behavior of Howe, Parrat, and Warren Trusses", Journal of Structural Division, ASCE, Vol. 95 No. ST2, Feb. 1969, pp. 183 - 202.
7. Dean, D. L. and Tauber, S. "Solutions for One Dimensional Lattices". Journal of the Engineering Mechanics Division ASCE Vol. 85, Oct. 1959, pp. 31 - 41.
8. Timoshenko, S. P. and Woinowsky - Krieger, S. Theory of Plates and Shells, Second Edition, McGraw Hill Book Company, Inc., New York 1959.
9. Heki, K. and Saka, T., "Stress Analysis of Lattice Plates as Anisotropic Continuum Plates". Proceedings of the 1971 LASS, Pacific Symposium, Part II on Tension Structures and Space Frames, Tokyo and Kyoto, Japan 1972, pp. 663 - 674.
10. Sun, C. T. and Yong, T. Y., "A Continuum Approach Toward Dynamics of Grid Works", Journal of Applied Mechanics, March 1973.
11. Noor, A. K., Anderson, M. C., and Greene, W. H., "Continuum Models for Beam-Like and Plate-Like Lattice Structures". AIAA Journal, Vol. 16 No. 12, December 1978, pp. 1219 - 1228.
12. "SAP IV, Structural Analysis Program for Static and Dynamic Response of Linear Systems", Bathe, K. J., Wilson, E. L., and Peterson, F. E. College of Engineering University of California, Berkeley California, June 1973.

13. Nayfeh, A. H. and Hefzy, M. S., "Continuum Modeling of the Mechanical and Thermal Behavior of Discrete Large Structures", AIAA Journal, Vol. 19, June 1981, pp. 766 - 773.
14. Mathlab Group, MACSYMA Reference Manual, Version Nine, Massachusetts Institute of Technology, 1977.
15. Noor, A. K. and Anderson, C. M. "Computerized Symbolic Manipulation in Structural Mechanics - Progress and Potential". Trends in Computerized Structural Analysis and Synthesis, NASA Langley Research Center, 1978.
16. Clough, R. W. and Penzien, J., Dynamics of Structures, McGraw Hill Book Company, 1975.
17. Chui and Taoka, "Tower Response to Actual and Simulated Wind Forces", Journal of Structural Division, ASCE, No. St9, Sept. 1973, pp. 1911 - 1929.
18. Hagler, T., "Building Large Structures in Space", Astronautics and Aeronautics, Vol. 15, No. 5, May 1976, pp. 56 - 61.
19. Mikulas, Martin M., Jr. Bush, Harold G., and Card, Michael F., "Structural Stiffness, Strength and Dynamic Characteristics of Large Tetrahedral Space Truss Structures", NASA TM X-74001, March 1977.
20. Kollar, L., "Analysis of Double-Layer Space Trusses with Diagonally Square Mesh by the Continuum Method", Acta Technica Academiae Scientiarum Hungaricae, Tomus 76(3-4), 1974, pp. 273 - 292.
21. Levi, M., Symbolic Algebra by Computer-Applications to Structural Mechanics. "AIAA/ASME 12th Structures, Structural Dynamics Materials Conference", Anaheim, California, April 1971.
22. Gupta, K. K. and E. W. Ng, "Symbolic Calculations in a Finite Dynamic Element Analysis". Proceedings of the 1977 MACSYMA User's Convention, pp. 151 - 160. NASA CP-2012, 1970.
23. Noor, A. K., Greene, W. H., and Anderson, M. S., "Continuum Models for Static and Dynamic Analysis of Repetitive Lattices", proceeding of the AIAA/ASME/SAE 18th Structures, Structural Dynamics and Material Conference, March 1977, pp. 299 - 310.
24. E. W. Ng, "Observations on Approximate Intergrations". Proceedings of the 1977 MACSYMA User's Conference NASA CP-2012, 1977, pp. 177 - 179.
25. Geneserth, M. R., "An Automated Consultant for MACSYMA". Proceedings of the 1977 MACSYMA User's Conference NASA CP-2012, 1977, pp. 309 - 313.
26. Gaylord and Gaylord, Structural Engineering Handbook, Second Edition, McGraw Hill Book Company, 1979.

APPENDIX A
 Equivalent Stiffness and Mass Coefficients
 of Planar Trusses

A.1 Derivation of the Equivalent stiffness coefficients of Planar Truss

As previously discussed in Chapter III, the general form of the constitutive relationships can be expressed as follows:

$$\begin{bmatrix} N_x \\ M_x \\ Q_x \\ N_y \end{bmatrix} = \begin{bmatrix} c_{11} & c_{12} & c_{13} & c_{14} \\ & c_{22} & c_{23} & c_{24} \\ \text{symmetric} & & c_{33} & c_{34} \\ & & & c_{44} \end{bmatrix} \begin{bmatrix} e_x^o \\ k_x^o \\ \gamma_{xy}^o \\ e_y^o \end{bmatrix} \quad (\text{A.1})$$

Equations (A.1) are further simplified to match the ordinary shear deformation beam theory by solving for e_y^o in terms of the other strain parameters e_x^o , k_x^o , and γ_{xy}^o . This can be accomplished by considering the case of axial load only i.e. set $M_x = Q_x = N_y = 0$ which yields to the following expression:

$$(\text{EAL}) e_y^o = 0 \quad (\text{A.2})$$

Since (EAL) cannot be zero, therefore, e_y^o must be zero. In other words, the compatibility is satisfied at the interface of any two adjacent elements.

Substituting back into Equation (A.1), and solving for N_x yields the following:

$$N_x = (C_{11} - C_{13} \frac{L}{h}) e_x^0 + C_{12} K_x^0 \quad (A.3)$$

where C_{ij} expressions are listed in Table 3.1; therefore

$$\begin{aligned} N_x &= [EAL (2 + \frac{L}{D})^3 - EAh (\frac{L}{D})^3 \frac{L}{h}] e_x^0 \\ &= (2 EAL) e_x^0 = C_{11} e_x^0 \\ \bar{C}_{11} &= \frac{C_{11}}{L} = 2EA \end{aligned} \quad (A.4)$$

where \bar{C}_{11} is the extensional stiffness of the equivalent continuum beam model.

In like manner, consider the case of pure bending i.e. $M_x \neq 0$ and set $N_x = Q_x = N_y = 0$, the following expression can then be obtained;

$$M_x = C_{21} e_x^0 + C_{22} K_x^0 + C_{23} \gamma_{xy}^0 + C_{24} e_y^0 \quad (A.5)$$

Substitute the expressions of C_{ij} from Table 3.1 and $e_y^0 = 0$, Equation (A.5) yields:

$$\begin{aligned} M_x &= \frac{1}{2} EAL h^2 K_x^0 \\ &= C_{22} K_x^0 \end{aligned}$$

Therefore;

$$\bar{C}_{22} = \frac{1}{2} EAh^2 \quad (A.6)$$

where \bar{C}_{22} is the equivalent bending stiffness coefficient of the equivalent continuum model.

Similarly, in the case of pure shear i.e. $Q_x \neq 0$, and set $N_x = M_x = N_y = 0$, the following expression is obtained

$$Q_x = \frac{EAL^2h^2}{D^3} \left(1 - \frac{L^3}{L^3 + 2D^3}\right) \gamma_{xy}^o \quad (A.7)$$

$$= \bar{c}_{33} \gamma_{xy}^o$$

Therefore;

$$\bar{c}_{33} = \frac{EALh^2}{D^3} \left(1 - \frac{L^3}{L^3 + 2D^3}\right) \quad (A.8)$$

where \bar{c}_{33} is the equivalent shear stiffness coefficient of the equivalent continuum model.

Therefore, equation (A.1) can then be expressed in its final matrix form as follows:

$$\begin{bmatrix} N_x \\ M_x \\ Q_x \end{bmatrix} = \begin{bmatrix} \bar{c}_{11} & 0 & 0 \\ 0 & \bar{c}_{22} & 0 \\ 0 & 0 & \bar{c}_{33} \end{bmatrix} \begin{bmatrix} e_x^o \\ k_x^o \\ \gamma_{xy}^o \end{bmatrix} \quad (A.9)$$

where the values of \bar{c}_{ij} are listed in Table 3.2

A.2 Derivation of the Equivalent Mass Coefficients of Planar Truss

The kinetic energy of the continuum beam model, as discussed previously in Chapter III, can be expressed in terms of the nodal displacement parameters as:

$$T = \frac{\omega^2}{6} \sum_{\text{Memb.}} \rho AL \left(u_i^2 + u_i u_j + u_j^2 + v_i^2 + v_i v_j + v_j^2 \right) \quad (A.10)$$

where the nodal displacement u and v can be obtained from the kinematic hypothesis as follows:

$$u = u^0 + y \theta^0 \quad (\text{A.11})$$

$$v = v^0 + y e_y^0 \quad (\text{A.12})$$

By direct substitution into Equation (A.10), the expressions of kinetic energy for the planar truss considered become,

$$T_1 = \frac{1}{2} \omega^2 \rho A L \left[(u^0 + \frac{h}{2} \theta^0)^2 + (v^0)^2 \right] \quad (\text{A.13})$$

$$T_2 = \frac{1}{2} \omega^2 \rho A L \left[(u^0 - \frac{h}{2} \theta^0)^2 + (v^0)^2 \right] \quad (\text{A.14})$$

$$T_3 = T_4 = \frac{1}{4} \omega^2 \rho A h \left[(u^0)^2 + \frac{h^2}{12} (\theta^0)^2 + (v^0)^2 \right] \quad (\text{A.15})$$

$$T_5 = \frac{1}{2} \omega^2 \rho A D \left[(u^0)^2 + \frac{h^2}{12} (\theta^0)^2 + (v^0)^2 \right] \quad (\text{A.16})$$

Based on a consistent mass approach, the kinetic energy expression of the equivalent continuum model can be written in matrix form as:

$$T = \frac{\omega^2}{2} \begin{bmatrix} u^0 & v^0 & \theta^0 \end{bmatrix} \begin{bmatrix} \bar{m}_{11} & \bar{m}_{12} & \bar{m}_{13} \\ & \bar{m}_{22} & \bar{m}_{23} \\ \text{symmetric} & & \bar{m}_{33} \end{bmatrix} \begin{bmatrix} u^0 \\ v^0 \\ \theta^0 \end{bmatrix} \quad (\text{A.17})$$

$$\text{where } \bar{m}_{ij} = \frac{1}{L} \left(\frac{\partial^2 T}{\partial d_i \partial d_j} \right)$$

The centroid of the repeating element has been chosen as the origin of the section, and the inertia terms associated with e_y^0 as well as its derivatives have been neglected. This results in eliminating the coupling terms of the equivalent mass matrix coefficients, that is $\bar{m}_{12} = \bar{m}_{13} = \bar{m}_{23} = 0$. The extentional mass density coefficient \bar{m}_{11} and \bar{m}_{22} in the x and y directions, respectively along with the rotary mass inertia coefficient \bar{m}_{33} are presented in Table 3.2 for the planar truss studied in this dissertation.

APPENDIX "B"
 STRAIN ENERGY AND KINETIC ENERGY OF
 THE THREE DIMENSIONAL TOWERS

The expressions for the strain energy of a pin connected tower with triangular cross sections can be expressed as follows:

$$U = \sum_{k=1}^n \frac{1}{2} \{d\}^t [\zeta^{(k)}]^t [K^{(k)}] [\zeta^{(k)}] \{d\} \quad (B.1)$$

where $\{d\}$ is the nodal displacements vector of a typical member defined in space by the nodal point i and j .

The expression for the nodal displacement vector of a pin connected element is given by:

$$\{d\}^t = [u^{(i)} \quad v^{(i)} \quad w^{(i)} \quad u^{(j)} \quad v^{(j)} \quad w^{(j)}]_{1 \times 6} \quad (B.2)$$

The elemental stiffness matrix $K^{(k)}$ of a typical truss element k in the local coordinated system is given by

$$[K^{(k)}] = \frac{AE}{L} \begin{bmatrix} 1 & -1 \\ -1 & 1 \end{bmatrix}_{2 \times 2} \quad (B.3)$$

The transformation matrix ζ for a pin-jointed bar element oriented arbitrary in space (which relates the displacements in local coordinates to those in global coordinates) is expressed as follows:

$$[\zeta] = \begin{bmatrix} 1 & m & n & 0 & 0 & 0 \\ 0 & 0 & 0 & 1 & m & n \end{bmatrix}_{2 \times 6} \quad (B.4)$$

where l , m , and n are the direction cosines of a typical truss element.

The global stiffness matrix of a typical truss element is given by:

$$[\bar{K}^{(k)}] = [\xi]^t [K^{(k)}] [\xi] \quad (B.5)$$

Substituting of Equation (B.3) into Equation (B.5) leads to the elemental global stiffness matrix $[\bar{K}^{(k)}]$ which can be expressed as follows:

$$[\bar{K}^{(k)}] = \frac{EA}{L} \begin{bmatrix} l^2 & lm & ln & -l^2 & -lm & -ln \\ ml & m^2 & mn & -ml & -m^2 & -mn \\ nl & nm & n^2 & -nl & -nm & -n^2 \\ -l^2 & -lm & -ln & l^2 & lm & ln \\ -ml & -m^2 & -mn & ml & m^2 & mn \\ -nl & -nm & -n^2 & nl & nm & n^2 \end{bmatrix} \quad (B.6)$$

6x6

The kinetic energy expression, based on a consistent mass formulation, is given by

$$T = \frac{1}{2} \omega^2 \sum_{k=1}^n \{d\}^t [\xi^{(k)}]^t [M^{(k)}] [\xi^{(k)}] \{d\} \quad (B.7)$$

where

$[M^{(k)}]$ is the elemental consistent mass matrix of a typical member k;

$[z^{(k)}]$ is the element transformation matrix;

$\{d\}$ nodal displacements vector; and

ω is the natural circular frequency of vibration.

The equivalent mass matrix for a pin-jointed member can be obtained by applying Hamilton's Principle which results in the following expression for the elemental mass matrix

$$[M^{(k)}] = \frac{\rho AL}{6} \begin{bmatrix} 2I & I \\ I & 2I \end{bmatrix}_{6 \times 6} \quad (B.8)$$

The (B.8) expression is invariant with respect to the selected set of axes. In the special case when only motion along the bar is considered, the expression (B.8) reduces to:

$$[m] = \frac{\rho AL}{6} \begin{bmatrix} 2 & 1 \\ 1 & 2 \end{bmatrix}_{2 \times 2} \quad (B.9)$$

where ρ is the mass density per unit length of the member; and

$[I]$ in equation (B.8) is three by three identity matrix.

APPENDIX (C)

LISTING OF MACSYMA PROGRAM FOR THE ANALYSIS
OF TOWERS WITH VARIABLE TRIANGULAR CROSS SECTIONS

```

/* PART 1: INPUT DATA
   LBAR = LENGTH OF REPEATING ELEMENT      */$
   LBAR: L

/* COORDINATES OF NODES OR REPEATING ELEMENT AS FUNCTION OF THE
   INCLINATION ANGLE (BETA) OF TOWER LEGS      */$
   H: B/2 *SQRT (3) $
   XX {1} : XX {2}: XX {3}: - L/2 $
   XX {4}: XX {5}: XX {6}: L/2 $
   YY {1}: YY {3}: (B + L * TAN (BETA)) * SQRT (3)/6 $
   YY {2}: -2* (B + L * TAN (BETA)) *SQRT (3)/6 $
   YY {4}: YY {6}: (B - L * TAN (BETA)) * SQRT (3)/6 &
   YY {5}: - 2* (B - L * TAN ( BETA)) * SQRT (3)/6 $
   ZZ {1}: - (B + L * TAN (BETA))/2 $
   ZZ {2} : ZZ {5}: 0 $
   ZZ {3}: (B + L * TAN (BETA))/2 $
   ZZ {4}: - (B - L * TAN (BETA))/2 $
   ZZ {6}: (B - L * TAN (BETA))/2 $

/* CHARACTERISTICS OF THE MEMBERS OF THE REPEATING ELEMENT;
   THE PROPERTY LIST CONTAINS NODAL CONNECTIVITIES, YOUNG'S MODULUS,
   CROSS SECTIONAL AREA, LENGTH, MATERIAL DENSITY, AND THE COEFFICIENT
   OF THERMAL EXPANSION FOR EACH MEMBER.      */$

```

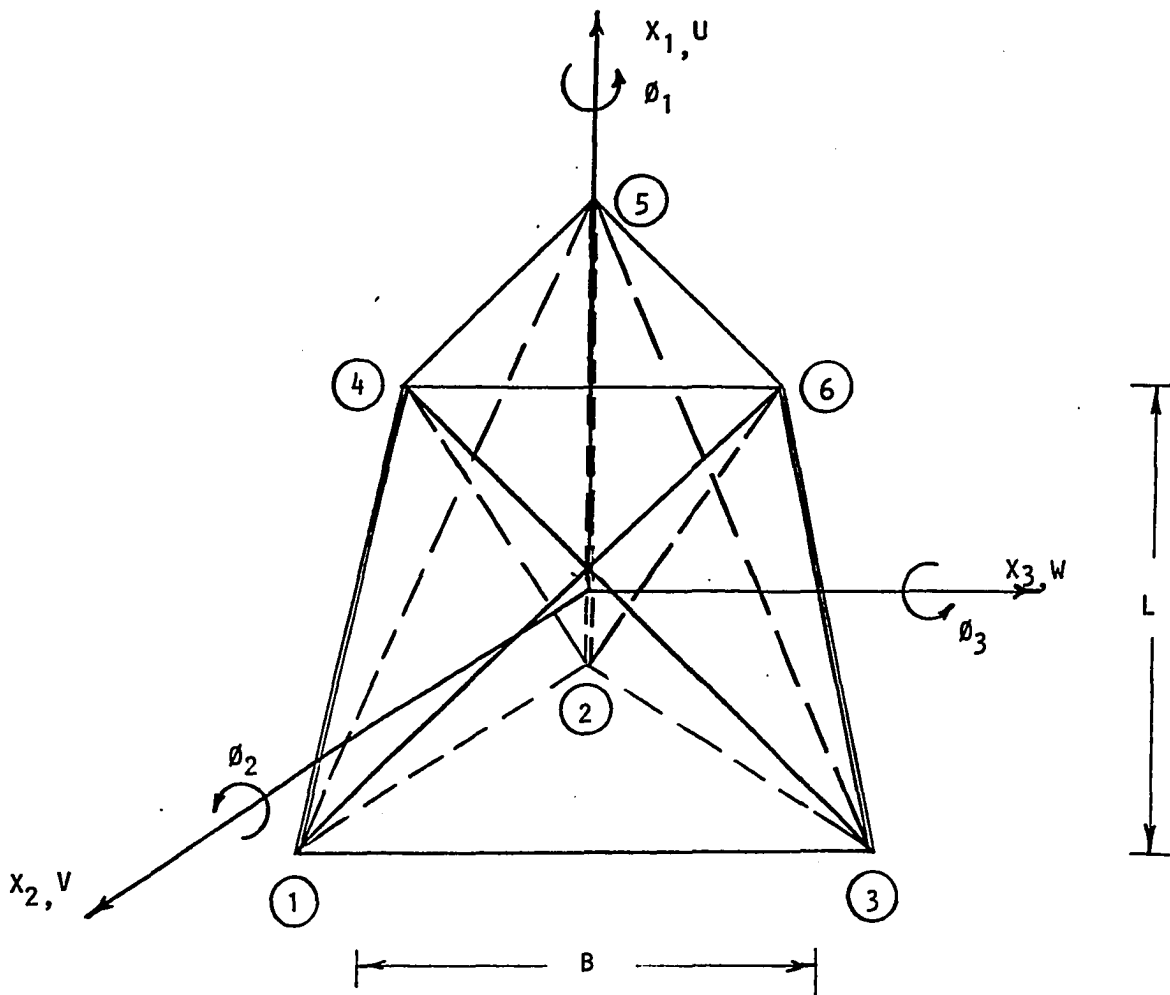

FIGURE C.1 - REPEATING ELEMENT OF TOWER WITH VARIABLE TRIANGULAR CROSS SECTION USED IN MACSYMA PROGRAM

PROP: {

(1,2, EB, AB/2, B + L * TAN (BETA), RHOB, ALPB),
 (2, 3, EB, AB/2, B + L * TAN (BETA), RHOB, ALPB),
 (3, 1, EB, AB/2, B + L * TAN (BETA), RHOB, ALPB),
 (4, 5, EB, AB/2, B - L * TAN (BETA), RHOB, ALPB),
 (6, 4, EB, AB/2, B - L * TAN (BETA), RHOB, ALPB),
 (1, 4, E1, A1, L/COS (BETA), RH01, ALP1),
 (2, 5, E1, A1, L/COS (BETA), RH01, ALP1),
 (3, 6, E1, A1, L/COS (BETA), RH01, ALP1),
 (1, 6, ED, AD, D, RHOD, ALPD),
 (4, 3, ED, AD, D, RHOD, ALPD),
 (4, 2, ED, AD, D, RHOD, ALPD),
 (5, 1, ED, AD, D, RHOD, ALPD),
 (6, 2, ED, AD, D, RHOD, ALPD),
 (5, 3, ED, AD, D, RHOD, ALPD) } \$

/* PART 2; THERMOELASTIC STRAIN ENERGY & STIFFNESS AND THERMAL
 COEFFICIENTS OF THE FULL THEORY */

DEPENDS ({EPS 10, EPS20, EPS30, TEPS120, TEPS130, TEPS230,
 UBAR, VBAR, WBAR, PS10, KAP20, KAP30, KAPBAR, KAPTO, UO, VO,
 WO, PHI1, PHI3, TO}, X1) \$

RATFAC: TRUE \$

SHOWTIME: TRUE \$

/* EXACT REPRESENTATIONS OF THE DISPLACEMENT FIELDS U, V, W AS
 FUNCTIONS OF X1 ARE GIVEN BY THE FOLLOWING EXPRESSION */\$

```
DISPLACEMATRIX: MATRIX (
  { U0, - PHI3 , PHI2 } ,
  { V0, EPS20 , - PHI1 + TEPS230/2},
  { W0, PHI1 + TEPS230/2, EPS30 )} $
```

```
/* EPS = LIST OF ENGINEERING STRAIN COMPONENTS EPS 11, EPS22,
EPS33, TEPS12, TEPS13, TEPS23 */$
```

```
U: DISPLACEMATRIX. TRANSPOSE ({1, X2, X3, X2 * X3}) $
```

```
U: TRANSPOSE (U) {1} $
```

```
TRANSPOSE (U) ;
```

```
EPS: {
```

```
  DIFF (U {1}, X1),
```

```
  DIFF (U {2}, X2),
```

```
  DIFF (U {3}, X3),
```

```
  DIFF (U {1}, X2) + DIFF (U {2}, X1),
```

```
  DIFF (U {2}, X3) + DIFF (U {3}, X2) $
```

```
SUBLIST: {
```

```
  'DIFF (U0, X1) = EPS10,
```

```
  'DIFF (V0, X1) = TEPS120 + PHI3,
```

```
  'DIFF (W0, X1) = TEPS130 - PHI2,
```

```
  'DIFF (PHI1, X1) = KAP10,
```

```
  'DIFF (PHI2, X1) = KAP30,
```

```
  'DIFF (PHI3, X1) = KAP20};
```

```
EPS: EXPAND (SUBST (SUBLIST, EPS)) $
```

```
TRANSPOSE (EPS) $
```

```
/* STRAINS AT X1 ≠ 0 ARE FOUND BY TRUNCATED TAYLOR SERIES ABOUT
```

```

XI = 0 BEING THE CENTER OF THE REPEATING ELEMENT
CALCULATE THE STRAIN ENERGY UU      */

UU: 0 $
FOR K THRU LENGTH (PROP) DO (
LXI: XX {PROP (K,1)} ,
LYI: YY {PROP (K,1)} ,
LZI: ZZ {PROP (K,1)} ,
LXJ: XX {PROP (K,2)} ,
LYJ: YY {PROP (K,2)} ,
LZJ: ZZ {PROP (K,2)} ,
/* LEN IS THE LENGTH OF MEMBER K
L1; L2; , L3 ARE THE DIRECTION COSINES OF MEMBER K */
L1: (LXJ - LXI) /LEN,
L2: (LYJ - LYI) /LEN,
L3: (LZJ - LZI) /LEN,
/* EVALUATE THE STRAINS AT THE CENTER OF MEMBER K */
CENTER: {XX1 = (LXI + LXJ) /2, X2 = (LYI + LYJ) /2, X3 = (LZI + LZJ)/2} ,
EPS 11: SUBST (CENTER, EPS {1} ),
EPS: SUBST (CENTER, EPS {2} ),
EPS33: SUBST (CENTER, EPS {3} ),
TEPS12: SUBST (CENTER, EPS {4} ),
TEPS13: SUBST (CENTER, EPS {5} ),
TEPS23: SUBST (CENTER, EPS {6} ),
TEMPERATURE: SUBST (CENTER, T0 + X2 * T2 + X3 * T3 + X2 * X3 * T23),
/* AXIAL STRAINS IN MEMBERS AS A FUNCTION OF THE STAIN COMPONENTS IN
COORDINATE DIRECTIONS */

```

```

EPSMEM: EPS11 * L1 * L1 + EPS22 * L2 * L2 * EPS33 * L3 * L3 + TEPS 12
      * L1 X L2 + TEPS13 * L1 * L3 + TEPS23 * L2 * L3 ,
EPSMEM: RATSIMP (EPSMEM) - PROP {K,7} * TEMPERATURE,
UU: UU + PROP {K,3} * PROP {K,4} * PROP {K,5} * EPSMEM ^ 2/2 ) $
/* LIST OF VARIABLES AND DERIVATIVES CONTAINED IN UU */
SHOWRATVARS (UU);
/* THE TERMS IN UU CONTAINING THE QUANTITIES DIFF (TEPS230,XI), DIFF
   (EPS20, XI), DIFF (EPS30,XI) WILL BE IGNORED BECAUSE THESE QUANTITIES
   MUST BE ZERO TO HAVE COMPATIBILITY BETWEEN REPEATING ELEMENT */
VARLIST: {EPS10, KAP20, DAP30, TEPS120, TEPS130, KAPTO, TEPS230,
   EPS20, EPS30, TO, T2, T3.};
NUMBERVARS: LENGTH (VARLIST);
/* COMPUTE THE STIFFNESS AND THERMAL COEFFICIENTS CC {I,J} OF THE FULL
   THEORY
   FOR I THRU NUMBERVARS DO (
     (I: DIFF (UUILBAR, VARLIST {I} ),
     FOR J THRU I DO (
       CC {I,J} : DIFF (CI, VARLIST {J} ),
       CC {I,J} : EXPAND (RATSIMP (CC {I,J} )) ) ) $
   KILL (ALLBUT (LBAR, PROP, XX, YY, ZZ, VARLIST, NUMBERVARS,
   CC, DISPLACEMATRIX, DEPENDENCIES));
/* PART 3; STIFFNESS AND THERMAL COEFFICIENTS OF ENGINEERING THEORY. */
NND: 6
NNU: NUMBERVAR $
NNL: NNU-3 $

```

```

FOR I THRU NNU DO FOR J THRU I DO
  IF CC {I,J} = 0 THEN
    C {I,J} : C {J,I} : F {I,J} : F {J,I} : 0 ELSE
    F {I,J} : F {J,I} : "*" $
/* MATI IS A MATRIX WHICH INDICATES BY 0'S OR *'S WHICH ELEMENTS OF
C {I,J} ARE ZERO OR NONZERO */
MATI: GENMATRIX (F, NNU, NNU) $
FOR I: NNL STEP-1 THRU NND + 1 DO FOR J THRU I-1 DO
  IF C {I,J} ≠ 0 THEN (
    FOR K: I THRU J DO C {J,K} : C {J,K} - C {I,K} *
    C {I,J} / C {I,I},
    FOR L: NNL + 1 THRU NNU DO C {L,J} : C {L,J} - C {L,I}
    * C {I,J} / C {J,I} ) $
/* COMPUTE AND DISPLAY THE STIFFNESS COEFFICIENTS C {I,J} FOR
THE ENGINEERING THEORY */

FOR I THRU NND DO FOR J THRU I DO
  IF C {I,J} ≠ 0 THEN
    C {I,J} : SUBST (C = CC, C I, J ),
    C {I,J} : EV(C {I,J} , EVAL),
    C {I,J} : C {J,I} : FACTOR (RATSIMP (C {I,J} )),
    DISPLAY (C {I,J} ) ) $
CCC: GENMATRIX (C, 6, 6) $
/* COMPUTE AND DISPLAY THE THERMAL COEFFICIENTS C I, J FOR
ENGINEERING THEORY. */
FOR I: NNL + 1 THRU NNU DO FOR J THRU NND DO
  IF C {I,J} ≠ 0 THEN (

```

```

C {I,J} : SUBST (C=CC, C {I,J} ),
C {I,J} : -EV (C {I,J} , EVAL),
C {J.1} : C {J.1} : FACTOR (C {I,J} ) ) $
CCT: GENMATRIX (C,6,NNU,1,NNL+!).
      {TO, 'DIFF (TO, X2), 'DIFF (TO, X3), 'DIFF (TO, X2,1,X3,1)} ;
KILL (LABELS, C,CC,F,MAT1) $
      {VALUES, ARRAYS, FUNCTIONS};

```

/* PART 4; KINETIC ENERGY AND EFFECTIVE MASS COEFFICIENTS */

```

MASSMATRIX: MATRIX (
{ M0 , M02, M03 },
{ M02 , M22, M23 },
{ M03 , M23, M33} ) $
TT: (OM 2 * LBAR/2) * (M0 * (UO * UO + VO * VO + WO * WO)
+ 2 * M02 * (WO * PHI1 - UO * PHI3)
+ 2 * M03 * (UO + PHI2 - VO * PHI1) - 2 * M23 * PHI2 * PHI3
+ M22 * (PHI1 2 + PHI3 2)
+ M33 * (PHI1 2 + PHI2 2) );

```

/* TT = KINETIC ENERGY OF EQUIVALENT CONTINUUM BEAM WHERE OM IS THE
CIRCULAR FREQUENCY OF VIBRATION

TTT = KINETIC ENERGY OF REPEATING ELEMENT */ \$

TTT: 0 \$

FOR K THRU LENGTH (PROP) DO (

```

AI: {1,YY {PROP {K,1}} , ZZ {PROP {K,1}} , YY {PROP {K,1}} *
      {ZZ} PROP {K,1}} }

```

```

AJ: {1, YY {PROP {K,2}} , ZZ {PROP {K,2}} , YY {PROP {K,2}} *
      ZZ {PROP {K,1}} },

```

```

VELLI: OM*DISPLACEMATRIX. TRANSPOSE (AI),
VELJ: OM*DISPLACEMATRIX. TRANSPOSE (AJ),
TTT: TTT + (PROP {K,4} * PROP {K,5} * PROP {K,6}/6) *
      (VELI. VELI + VELI. VELJ + VELJ. VELJ) ) $
VARLIST: LIST OF VARS (DISPLACEMATRIX) $
NUMVARS: LENGTH (VARLIST);
FOR I THRU NUMVARS DO (
  MI: DIFF (TT-TTT) / (LBAR * OM 2), VARLIST I ),
FOR J THRU I DO (
  M{I,J} : DIFF (MI, VARLIST {J} ),
  M{I,J} : M{J,I} : RATSIMP (M{I,J} ) ) ) $
LIST: LIST OF VARS (MASSMATRIX) $
GLOBALSOLVE: .TRUE $
FOR I THRU NUMVARS DO FOR J THRU I DO (
  MM {I,J} : EV (M {I,J} , EVAL),
FOR K IN LIST DO
  IF NOT FREEOF (K,MM {I,J} ) THEN LINESOLVE (MM {I,J} , K) ) $
FOR VAR IN LIST DO
  IF (TEMP: EV (VAR, EVAL)) ≠ 0 THEN DISPLAY (VAR = EXPAND (TEMP)) $
NONZERO DISPLAY (SYMMETRICMATRIX): = BLOCK ( {MAT, TEMP} ,
  MAT: EV (SYMMETRICMATRIX),
FOR I THRU LENGTH (MAT) DO
FOR J THRU I DO
  IF (TEMP: EXPAND (MAT {I,J} )) ≠ 0
THEN DISP (ARRAYMAKE (SYMMETRICMATRIX, {I,J} = TEMP)) $
NONZERO DISPLAY ('M) $

```

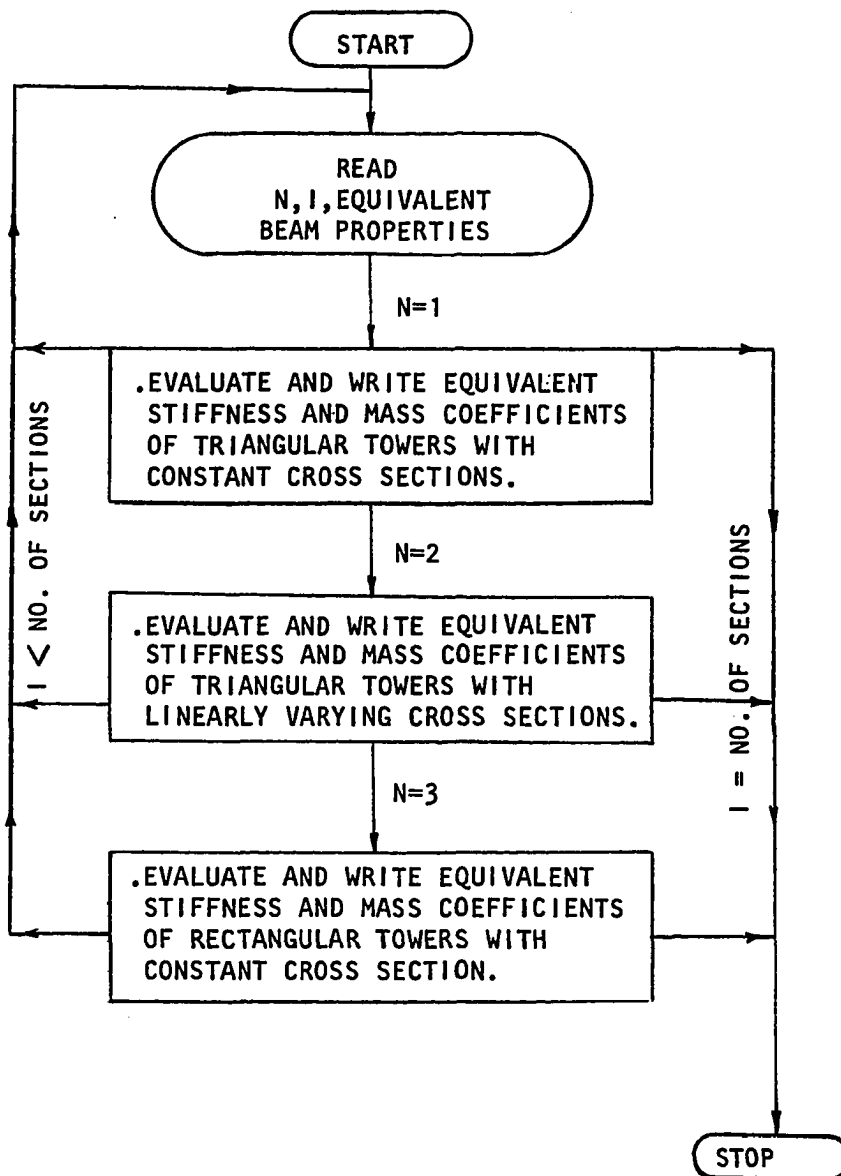

FIGURE C.2- FLOW CHART OF FORTRAN IV PROGRAM USED IN THE PRESENT STUDY TO EVALUATE THE EQUIVALENT CONTINUUM PROPERTIES OF DIFFERENT LATTICED STRUCTURES

FORTRAN IV PROGRAM TO EVALUATE THE EQUIVALENT
CONTINUUM PROPERTIES FOR DIFFERENT MATERIAL
PROPERTIES AND CONFIGURATION OF TOWERS

```

C      STIFF, AND MASS COEFF. FOR TOWERS WITH CONSTANT AND VARIABLE CROSS SECTIONS
C      M=NUMBER OF SECTION PROPERTIES SETS
      M=30
      DO 10 I=1,M
      READ (5,*) N,B      ,L      ,AB      ,AD      ,A1      ,EB      ,2ED
      ,E1      ,RHOB      ,RHOD      ,RH01,  U ,BETA
C      N IS CROSS SECTIONAL IDENTIFICATION NUMBER
C      N=1  (TRIANGULAR CROSS SECTION TOWERS WITH VARIABLE CROSS SECTIONS)
C      N=2  (RECTANGULAR CROSS SECTIONAL TOWERS)
C      N=3  (CONSTANT TRIANGULAR CROSS SECTIONAL TOWERS)
      TAN(BETA)=SIN(BETA)/COS(BETA)
      D=SQRT(L**2.+(B-L*TAN(BETA))**2.)
      G=E1/(2.+2.*U)
      IF (N.EQ.0) GO TO 200
      IF (N.EQ.2) GO TO 20
      IF (N.EQ.3) GO TO 15
      C11=27.*(2.*A1*AD*(COS(BETA))**3.*(TAN(BETA))**4.*E1*ED*L**4.
1 +2.*AB*AD*B*EB*ED*L**3.-4.*A1*AD*B**2.*(COS(BETA))**3.*(TAN(BETA))
1 **2.*E1*ED*L**2.+2.*A1*AD*B**4.*E1*ED*(COS(BETA))**3.
1 +A1*AB*B*D**3.*E1*EB*(COS(BETA))**3.)/(2.AD*ED*L**4.*
1 (TAN((BETA))**4.=12.*AD*B**2.*ED*L**2.*(TAN(BETA))**2.+
1 16.*A1*(COS(BETA))**3.*(TAN(BETA))**4.*D**3.*E1*L+18.*AD*B**4.

```

1 *ED+9.*AB*B*EB*D**3.)
 C22=3.*(2.*DA**2.*ED**2.*L**9.*(TAN(BETA))**6.-4.*AD**2.*B**2.

 1 *ED**2.*L**7.*(TAN(BETA))**4.+16.*A1*AD*D**3.*E1*ED*L**6

 1 *(COS(BETA))**3.*(TAN(BETA))**6.+2.*AD**2.*B**4.*ED**2.*L**5.
 1 *(TAN(BETA))**2.+9.*AB*AD*B*D**3.*EB*ED*L**5.*(TAN(BETA))

 1 **2.-20.*A1*AD*B**2.*D**3.*E1*ED*L**4.*(COS(BETA))**3.*
 (TAN(BETA))**4.+3.*AB*AD*B**3.*EB*ED*L**3.-8.*A1*AD*B**4.
 1 *D**3.*E1*ED*(COS(BETA))**3.*(TAN(BETA))**2.*2.*L**2.+12

 1 *A1*AD*
 1 B**6.*D**3.*E1*ED*(COS(BETA))**3.+6.*A1*AB*B**3.*D**6.*
 1 E1*EB*(COS(BETA))**3.)/(4.*D**3.*(2.*AD*ED*L**4.*(TAN(BETA))

 1 **4.+12.*AD*B**2.*ED*L**2.*(TAN(BETA))**2.+16.*A1*E1*L*
 2 D**3.*(COS(BETA))**3.*(TAN(BETA))**4.+18.*AD*ED*B**r.+9.
 2 *AB*B*D**3.*EB))
 C44=9.*(6.*AD**2.*ED**2.*ED**2.*L**5.*(TAN(BETA))**4.+4.*A1*AD*

 1 D**3.*E1*ED*L**4.*(COS(BETA))**3.*(TAN(BETA))**6.-12.*AD**2.*

 1 B**4.*(TAN(BETA))**2.*
 1 ED**2.*L**3.+AB*AD*B*(TAN(BETA))**2.*D**3.*EB*ED*L**3.-8*

 1 A1*AD*B**2.*(COS(BETA))**3.*(TAN(BETA))**4.*D**3.*E1*ED*
 2 L**2.+6.*AD**2.*B**6.*ED**2.*L+3.*AB*AD*B**3.
 2 *D**3.*EB*ED*L+4.*A1*
 1 AD*B**4.*(COS(BETA))**3.*(TAN(BETA))**2.*D**3.*E1*ED+2.*A1*AB*

```

1 B*(COS(BETA))**3.*D**6.*E1*EB*(TAN(BETA))**2.)/(D**3.*
1 (2.*AD*(TAN(BETA))**4.*
1 ED*L**4.+12.*AD.*AD*B**2.*(TAN(BETA))**2.*ED*L**2.+16.*A1*(COS
1 (BETA))**3.*(TAN(BETA))**4.*D**3.*E1*L+18.*AD*B**4.*ED+
1 9.*AB*B*D**3.*EB))
   C66=AD*ED*L*(L*TAN(BETA))**2.+B**4.)/2.D**3.)
   C42=9.*B*(TAN(BETA))*(AD((2.*(TAN(BETA))**4.*ED**2.*L**7.
1 -2.*AD**2.*B**2.*(TAN(BETA))**2.*ED**2.*L**5.+2.*A1*AD*(COS
1 (BETA))**3.*(TAN(BETA))**4.*D**3.*E1*ED*L**4.+AD**2.*B**4.*ED
1 **2.*L**3.+2.*AB*AD*B*D**3.*EB*ED*L**2.-4.*A1*AD*B**2.*
1 (COS(BETA))**3.*(TAN(BETA))**2.*D**3.*E1*ED*L**2.+2.*A1*AD*B*
1 *4.*(COS(BETA))**3.*D**3.*E1*ED+A1*AB*B*(COS(BETA))**3.*D*6.
1 *E1*EB)/(D**3.*(2.*AD*(TAN(BETA))**4.*ED*L**4.+12.*AD
1 *B**2.*(TAN(BETA))**2.*ED*L**2.+16.*A1*(COS(BETA))**3.*
1 (TAN(BETA))**4.*D**3.*E1*L+18.*AD*B**4.*ED+9.*AB*B*D**3.*EB))
   AM1=6.*AD*D*RHOD/L+3.*AB*B*RHOB/L+3.*A1*RH01/COS(BETA)
   AM22=5.*AD*(TAN(BETA))**2.*D*L*RHOD/6.+AD*B**2.*D*RHOD/(2.*L)
1 +3.*AB*B*(TAN(BETA))**2.*L*RHOB/4.+AB*B**3.*RHOB/(4.*L)
1 +A1*(TAN(BETA))**2.*L**2.*RH01/(6.*(COS(BETA))
1 )+A1*B**2.*RH01/(2.*(COS(BETA))
   AEQ=C11/E1
   ASEQ=C44/G
   AJEQ=C66/G

```

12 CONTINUE

C PROPERTIES OF CONST. RECTANGULAR CROSS SECTION

20 DO 13 K=1,M

$$D=\text{SQRT}(B^{**2}+L^{**2}.)$$

$$G=E1/(2.+2.*U)$$

$$EL=EB$$

$$AL=AB$$

$$RHOL=RHOB$$

$$ANU=1.+(2.*B^{**3}.*ED*AD/(D^{**3}.*EB*AB))/(1.+EL*AL/(EB*AB*SQRT(2.)))$$

$$ANI1=1.+2.*B^{**3}.*ED*AD/(D^{**3}.*EB*AB)$$

$$C11=4.*E1*A1+8.*L^{**3}.*ED*AD/(ANU*D^{**3}.)$$

$$C22=B^{**2}.*E1*A1*B^{**2}.*L^{**3}.*ED*AD/(ANU1*D^{**3}.)$$

$$C44=4.*B^{**2}.*L*ED*AD/D^{**3}.$$

$$C66=2.*B^{**4}.*L*ED*AD/D^{**3}.$$

$$C42=0.0$$

$$AM1=4.*RH01*A1+4.*B*RHOB*AB/L+4.*B*RHOL*AL/(L*SQRT(2.))+$$

1 8.*D*RHOD*AD/L

$$AM22=B^{**2}.*RH01*A1+2.*B^{**3}.*RHOB*AB/(3.*L)+B^{**3}.*RHOL*AL*$$

1 (3.*L*SQRT(2.))+4.*B^{**2}.*D*RHOD*AD/(3.*L)

$$AM23=B^{**4}.*RH01*A1/4.+B^{**5}.*RHOB*AB/(12.*L)+B^{**5}.*RHOL*A$$

1 (4.*L*SQRT(2.))

2 +B^{**4}.*D*RHOD*AD/(6.*L)

$$AEQ=C11/E1$$

$$AIEQ=C22/E1$$

$$ASEQ=C44/G$$

$$AJEQ=C66/G$$

AM1L=AM1*L/2.

AM22L=AM22*L/2.

WRITE (5,100) C11,C22,C44,C66,C42,AM1,AM22

WRITE (5,300) AEQ,AIEQ,ADEQ, AM1L,AM22L,AJEQ

GO TO 10

C TRIANGULAR PROPERTIES OF CONST . SECT.

15 DO 12 J=1,M

D=DQRT (B**2.+L**2.)

G=E1/(2.+2.*U)

AMU=1.+(2.*B**3.*ED*AD)/(D**3.*EB*AB)

C11=3.*E1*A1+6.*L**3.*ED*AD/*AMU*D**3.)

C22=0.5*B**2.*E1*A1+B**2.*L**2.*ED*AD/(4.*AMU*D**3.)

C44=3.*B**2.*L*ED*AD/D**3.

C66=0.5*B**4.*L*ED*AD/D**3.

C42=0.0

AM1=3.*(TH01*A1+B*RHOB*AB/L+2.*D*RHOD*AD/L)

AM22=(B**2./2.)*(RH01*A1+0.5*B*RHOB*AB/L*D*RHOD*AD/L)

AEQ=C11/E1

AIEQ=C22/E1

ASEQ=C44/G

AJEQ=C66/G

AM1L=AM1*L/2.

AM22L=AM22*L/2.

WRITE (5,100) C11,C22,C44,C66,C42,AM1,AM22

WRITE (5,300) AEQ,AIEQ,ASEQ,AM1L,AM22L,AJEQ

GO TO 10

AM1L=AM1*L/2.

AM22L=AM22*L/2.

WRITE (5,150) AM23

WRITE (5,100) C11,C22,C44,C66,C42,AM1,AM22

WRITE (5,300) AEQ,AIEQ,ASEQ,AM1L,AM22L,AJEQ

GO TO 10

13 CONTINUE

10 CONTINUE

150 FORMAT(//,10X,'M2233-',3X,E15.6,///)

100 FORMAT(10X,//,10X,'STIFFNESS COEFFICIENTS',///,10X,'C11=',3X,

9 E15.6,/,10X,'C22=',3X,E15.6/,10X,'C44=',3X,E15.6,

6 /,10X,'C66=',3X,E15.6,/,10X,'C42=',3X,E15.6,

9 //,10X,'MASS COEFFICIENTS',//,10X,'M0=',3X,

7 E15.6,/,10X,'M22=',3X,E15.6,///)

300 FORMAT(10X,//,10X,'EQUVALENT COEFFICIENTS',//,10X,

1 'EQ. AXIAL AREA =',3X,E15.7,//,10X,'EQ. MOM. OF INERTIA=;

2 3X,E15.7,//,10X,'EQ. SHEAR AREA=',3X,E15.7,//,10X,

3 'EQ. EXTENTIAL INERTIA =',3X,E15.7,//,10X,

4 'EQ. ROTARY INERTIA =',3X,E15.7,//,10X,'EQ.TORSIONAL INERTIA=',

5 3X,E15.7,///)

200 STOP

RETURN

END

C EQUIVALENT MASS AND STIFF. COEFF. FOR A PLANAR TRUSS

C M=NUMBER OF SECTION PROPERTIES SETS

```

M=30
DO 10 I=1,M
READ (5,*) B,L,A,E,RHO,U
D=SQRT(B**2,+L**2.)
G=E/(2.+2.*U)
C11=2.*E*A
C22=E*A*B**2./2.
C44=E*A*L*B**2./D**3.-E*A*L**4.*B**2./(D**3.*L**3.+2.*D**6.)

AM1=RHO*A*(2.+B/L+D/L)
AM22=RHO*A*B**2./2.+(RHO*A*B**3.+RHO*A*D*B**2.)/12.*L
AEQ=C11/E
AIEQ=C22/E
ASEQ=C44/G
AJEQ=C66/G
AM1L=AM1*L
AM22L=AM22*L
WRITE (5,100) C11,C22,C44,C66,C42,AM1,AM22
WRITE (5,300) AEQ,AIEQ,ASEQ, AM1L,AM22L,AJEQ
TO TO 10
10 CONTINUE
100 FORMAT (10X,//,10X,'STIFFNESS COEFFICIENTS',///,10X,'C11=',3X,
9 E15.6,/,10X,'C22=',3X,E15.6,/,10X,'C44=',3X,E15.6,
6 /,10X,'C66=',3X,E15.6,/,10X,'C42=',3X,E15.6,
9 //,10X,'MASS COEFFICIENTS',//,10X,'M0=',3X,

```

```
7 E15.6,/,10X,'M22=' ,3X,E15.6,/// )
300 FORMAT(10X,/,10X,'EQUVALENT COEFFICIENTS',/,10X,
1 'EQ. AXIAL AREA =' ,3X,E15.7,/,10X,'EQ. MOM. OF INERTIA=' ,
2 3X,E15.7,/,10X,'EQ. SHEAR AREA=' ,3X,E15.7,/,10X,
3 'EQ. EXTENTIAL INERTIA =' ,3X,E15.7,/,10X,
4 'EQ. ROTARY INERTIA =' ,3X,E15.7,/,10X,'EQ. TORSIONAL INERTIA=' ,
5 3X,E15.7,///)
RETURN
END
```

AUTOBIOGRAPHICAL STATEMENT

Khaled A. Obeid was born in Alexandria, Egypt on May 16, 1948. After graduation from high school, he enrolled in Alexandria University, Egypt and graduated in June of 1971 with a Bachelor of Science degree with Honor in Civil Engineering. After which, he taught Civil Construction, Civil Drawings, and Hydraulics as a full time assistant professor in Alexandria University, Egypt.

In January of 1974, he entered the University of Southwestern Louisiana, Laffayette, Louisiana where he was awarded his Master of Science degree in Civil Engineering in May of 1975. While at the University of Southwestern Louisiana, he served as graduate research assistant and wrote his Master's thesis entitled "Rotary Inertia and Shear Effects on Dynamics of Frames". Upon finishing his Master's degree, he enrolled in Louisiana State University in August of 1975 at which he was awarded a research assistantship in Civil Engineering Department.

In August of 1976, he enrolled at Old Dominion University as a full time Doctoral student in Civil Engineering working in structural dynamics as his major and soil mechanics as his minor. During the first three years of his Doctoral study program, he serves as graduate teaching assistant in which he taught Materials, Hudraulics, and Soil Mechanics Laboratories. In the summer of 1977, he was involved in a crash analysis program conducted by NASA Langley Research Center in Hampton, Virginia.

The author has been a Professional Engineer in the State of Virginia since April of 1978. He is a member of the American Concrete Institute, American Society of Civil Engineers, the Engineers Club of Hampton Roads,

and the Virginia Society of Professional Engineers. He is presently associated with Glenn-Rollins and Associates Consulting Engineers in Norfolk, Virginia as a Senior Project Engineer.

He is married to the former Helen Ruth Barras of Lafayette, Louisiana and they have been blessed with two lovely children; Mohamed and Yasmin. Presently, they are residing in Virginia Beach, Virginia.