

University of Portland

Pilot Scholars

Engineering Undergraduate Publications,
Presentations and Projects

Shiley School of Engineering

4-12-2019

The Little Engine that Could : Development of an Electromechanical Valvetrain

Ryan Clarke

Follow this and additional works at: https://pilotscholars.up.edu/egr_studpubs

 Part of the [Mechanical Engineering Commons](#)

Citation: Pilot Scholars Version (Modified MLA Style)

Clarke, Ryan, "The Little Engine that Could : Development of an Electromechanical Valvetrain" (2019).
Engineering Undergraduate Publications, Presentations and Projects. 8.
https://pilotscholars.up.edu/egr_studpubs/8

This Student Project is brought to you for free and open access by the Shiley School of Engineering at Pilot Scholars. It has been accepted for inclusion in Engineering Undergraduate Publications, Presentations and Projects by an authorized administrator of Pilot Scholars. For more information, please contact library@up.edu.

SENIOR HONORS PROJECT

The Little Engine that Could

Development of an Electromechanical Valvetrain

Ryan Clarke

Department of Mechanical Engineering

Donald P. Shiley School of Engineering

University of Portland

Fall 2018 - Spring 2019

Team Members:

Ryan Clarke

Joseph McKeirnan

Emett Santucci

Isaac Yako

Special Thanks:

Matthias Farveleder

Faculty Advisor:

Dr. Jordan Farina

Industry Advisor:

Ryan Jefferis

Version April 12, 2019

Table of Contents	
EXECUTIVE SUMMARY	iii
ACKNOWLEDGEMENTS	iii
List of Figures	iii
List of Tables	iv
1. PROJECT INTRODUCTION	1
1.1. Problem Statement	1
1.2. Project Scope	1
2. BACKGROUND	1
2.1. Modern Gasoline Engine Operation	1
2.2. Inefficiencies Caused by the Camshaft-Based Valvetrain	3
2.3. Recent Valvetrain Design Innovations	6
2.4. Environmental and Societal Impacts	6
3. ELECTROMECHANICAL VALVETRAIN DESIGN	6
3.1. Design Considerations	7
3.2. Design Concepts	7
3.3. Design Criteria	9
3.4. Design Selection	9
4.2. Control System Prototyping	13
4.2.1. Electrical System Requirements	13
4.2.2. Control Software	14
5. FINAL DESIGN	14
5.1. Air Flow Control System	15
5.2. Valve Actuation Subsystem	15
5.3. Electrical System	17
6. CONCLUSIONS	17

EXECUTIVE SUMMARY

The goal of the present project is to design and implement an electromechanical valvetrain for a single-cylinder gasoline engine. This system is to replace the existing fully mechanical camshaft-based valvetrain with a computer-controlled system capable of independently controlling each engine valve. This system can improve the power and fuel efficiency of the engine by removing the inefficiencies caused by the camshaft-based valvetrain. Recently, the Camcon and FreeValve companies have each developed similar systems which replace the camshaft in automobile engines and provide up to 15% increases in fuel economy. The electromechanical valvetrain of this project uses high-speed electric air valves to control the flow of air to high-speed pneumatic rams which open and close the engine valves. A primary improvement of this system is the expected ability to open the engine valves faster than a camshaft-based valvetrain. The pneumatic-based design was chosen for its cost effectiveness, manufacturability and availability of suitable components to simplify production of a working system.

ACKNOWLEDGEMENTS

The members of the electromechanical valvetrain conversion team thank all those who shared their time, talent and experience to help make this project successful. We especially thank our faculty advisor, Dr. Jordan Farina, for constantly supporting our work on this project, and the Shiley School of Engineering's Shop Technicians Jared Rees and Jacob Amos for their hard work and support of this project. We also thank Ryan Jefferis for sharing his expertise as our industry advisor, and thank the Shiley School of Engineering's Lisa Bassett, Allen Hansen and Dean Sharon Jones for their support of this project. The team also thanks Matthias Farveleder, University of Upper Austria, for being an integral part of the team while studying at University of Portland during the Fall semester of 2018, and for continuing to work with us on the control system of the project during the Spring of 2019.

List of Figures

Figure 1: Cutaway Diagram of Internal Combustion Engine Cylinder	2
Figure 2: Operation of the four-stroke engine cycle	3
Figure 3: Components of the Camshaft-Based Valvetrain	4
Figure 4: Comparison of Valve Position in Cam and Cam-less Systems	5
Figure 5: Hydraulic System Concept	8
Figure 6: Electric System Concept	9
Figure 7: Initial Design of Pneumatically-Actuated Electromechanical Valvetrain	10
Figure 8: SX12 Valve from SMC Corporation	11
Figure 9: Prototype Pneumatic Actuation System	12
Figure 10: Schematic of Typical Fluid Actuator	12
Figure 11: Airpot Corporation Airpel AB Pneumatic Ram Schematic	13
Figure 12: Pulse-Width Modulated Power Signal Required by High Speed Valves	14
Figure 13: Prototype LabVIEW Control System Block Diagram	14
Figure 14: Air Flow Block	15
Figure 15: Model of Rocker Valve Actuation System	16

Figure 16: Final Valve Actuation System Assembly..... 16
Figure 17: Electrical Circuit Diagram..... 17

List of Tables

Table 1: Design Considerations 7
Table 2: Design Criteria..... 9

1. PROJECT INTRODUCTION

This project was undertaken as a year-long senior capstone project by a team of mechanical engineering students. The basic stages of the project were background research, brainstorming, design selection, component selection, prototyping, validation testing, design iteration and optimization. Details of the project's motivation and execution are as follows.

1.1. Problem Statement

This project seeks to design, build and implement a system which improves the performance and efficiency of an internal combustion engine by replacing the traditional camshaft-based valvetrain with a computer-controlled system. This change removes one of the last major inefficiencies in modern internal combustion engine design and has the potential to increase performance and reduce emissions without sacrificing the benefits which have made combustion engines a popular power source.

1.2. Project Scope

The intent of the Electromechanical Valvetrain capstone project was to design and build a valvetrain capable of independently controlling the intake and exhaust valves of a single-cylinder gasoline combustion engine. The system should improve engine efficiency and power output with minimal changes to all other engine characteristics. The abilities of the new system can be quantified using the University of Portland's water brake dynamometer, constructed by the 2017-2018 'SAE – Engine' capstone team. The scope of this project therefore includes renovation and upgrades to the dynamometer as needed to allow it to function properly and provide reliable data.

2. BACKGROUND

Internal combustion (IC) engines have been used for over a century and have been continuously improving¹. They are widely used in applications ranging from powering yard tools to propelling supertankers and are popular because they are a highly reliable and versatile power system.

2.1. Modern Gasoline Engine Operation

Gasoline engines harness energy from combustion of fuel to provide power. As seen in Figure 1, the basic parts of an internal combustion engine cylinder are quite simple. Combustion of fuel in the cylinder forces the piston down, which turns the crankshaft and provides power, in the form of rotational motion, to the load on the engine. The remaining parts shown in Figure 1 make up the engine's valvetrain, which operates the fuel intake and exhaust outlet valves of the cylinder. This figure shows an engine cylinder with a typical camshaft-based valvetrain. The camshaft (at left, holding cams) is connected by a timing belt or chain to the engine's crankshaft, and holds lobe-shaped pieces of metal (cams) which open the intake and exhaust valves by pushing up on the connection rods and working through rockers to push open the valves. As shown, springs are typically used to close the valves after the cam rotates past its point of maximum lift.

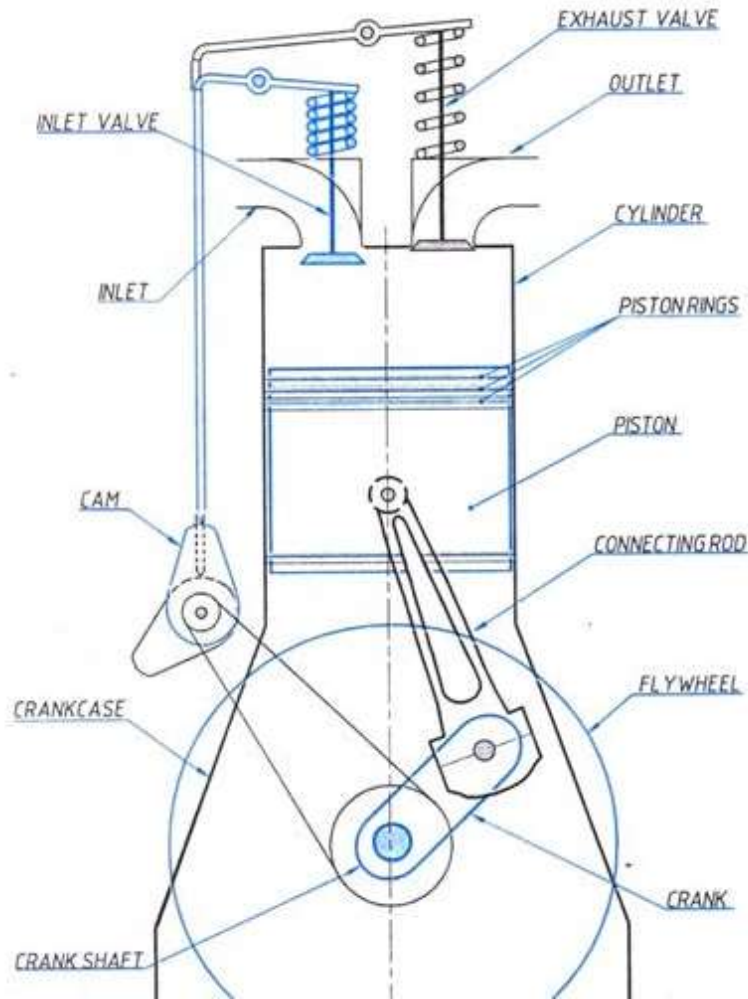

Figure 1: Cutaway Diagram of Internal Combustion Engine Cylinder²

Most modern gasoline engines operate using the four-stroke Otto Cycle. The four stages of this cycle dictate when each of the cylinder's valves must be open and when they must be closed. Figure 2 shows the four operations of the Otto Cycle which allow an engine to produce power. These are the intake, compression, power and exhaust strokes. In the intake stroke, fuel vapor and air are drawn into the cylinder through the intake valve. In the compression stroke, the cylinder's contents are compressed by the piston moving to the top of the cylinder. In the power stroke, the spark plug ignites the fuel-air charge and its combustion forces the piston down, rotating the crankshaft, and providing power to the system. In the exhaust stroke, the contents of the cylinder are pushed out through the exhaust valve as the piston returns to the top of the cylinder. Timing of fuel-air charge intake and exhaust outlet are controlled by the valvetrain and are clearly critical to efficient operation of the engine.

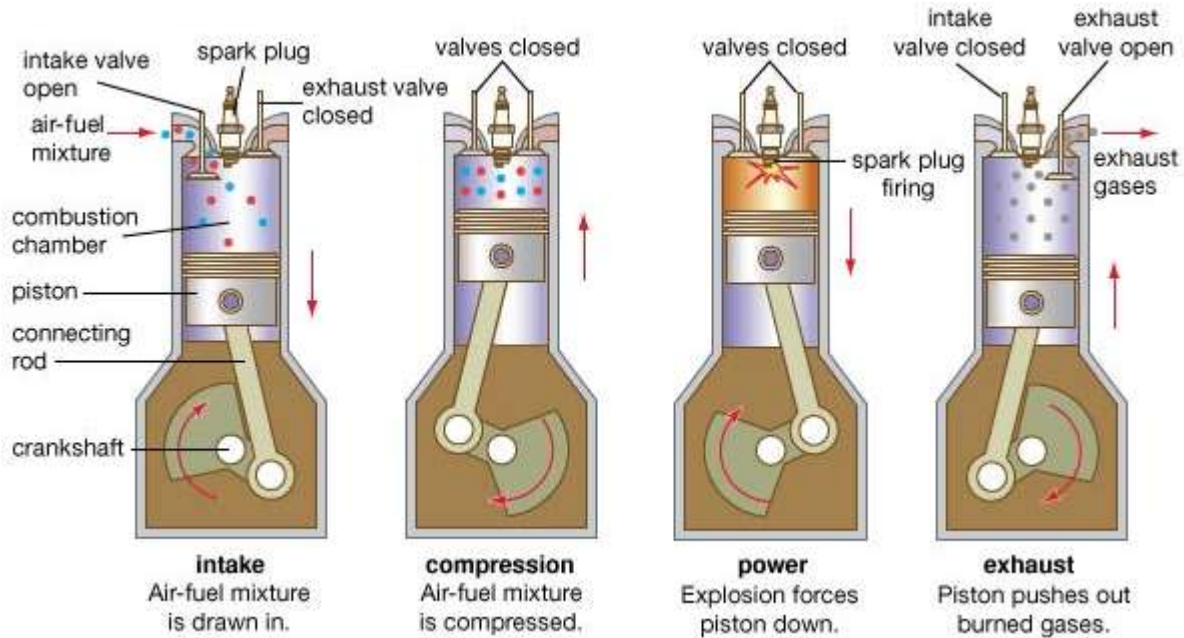

Figure 2: Operation of the four-stroke engine cycle³

2.2. Inefficiencies Caused by the Camshaft-Based Valvetrain

The current project focuses on building a system capable of solving the issues that arise from using a camshaft-based valvetrain. Figure 3 shows in more detail all the parts which allow the rotation of cams on the camshaft to open an engine cylinder's valves. In this project, a 10 horsepower Briggs and Stratton Model 19 engine was modified, and the valvetrain of Figure 3 is nearly identical to the system in the Model 19 engine. As seen in the figure, the cams on the camshaft translate the rotational motion of the camshaft into linear motion – opening the valves. Cams and camshafts have been used for hundreds of years to translate rotational into linear motion and continue to be used in modern IC engine valvetrains because they are effective and reliable. However, this system also introduces necessary inefficiencies.

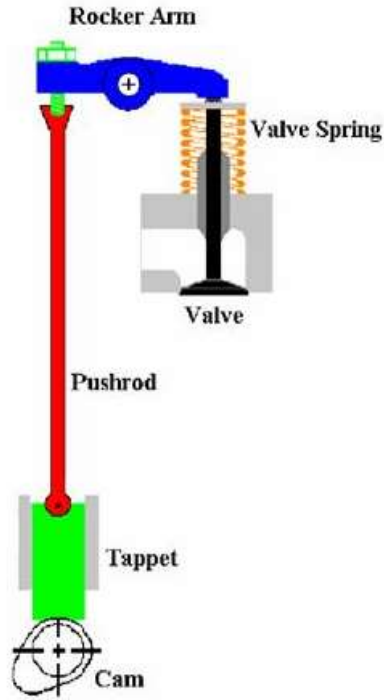

Figure 3: Components of the Camshaft-Based Valvetrain⁴

Despite its simplicity and reliability, the camshaft makes the valvetrain one of the least efficient systems in modern internal combustion engines. The main issue with the camshaft-based valvetrain is how it is powered. The direct mechanical connection from the crankshaft to the camshaft means that the cams always open their valves for the same proportion of each rotation of the engine. By extension, the amount of time each valve is open is a function of engine speed, and while the ideal timing of valves' operations also changes with engine speed, it is not always towards the timing brought about by the camshaft.

Many modern engines can operate from 1,000 rotations per minute (RPM) up to 9,000 RPM. While the camshaft will keep the engine valves opening during the same parts of each stroke in a four-cycle engine, inefficiency arises at high engine speeds when there is no longer enough time in the power stroke for the entire fuel charge to physically combust before the cam begins to open the exhaust valve. In this condition, unburnt fuel is exhausted from the engine and simply wasted.

Additionally, the power required from an engine changes during operation, and not always in direct proportion with engine speed. For example, revving a car's engine in idle gear to 5,000 RPM would run the valves the same as while climbing a mountain pass at 5,000 RPM. While the load on the engine and power required is quite different in these cases, the same amount of fuel will be provided to and burnt in the engine cylinders because the valvetrain's operation is fixed to engine speed.

Another issue that arises from the camshaft involves timing of the exhaust and intake valves. Many engines use a short period of overlap when both the exhaust and intake valves are open at the very end of the exhaust stroke and beginning of the intake stroke. Doing this at the ideal engine speed can improve engine power by pulling fuel into the cylinder more effectively. However, at higher or lower than average engine speeds it can lead to poor engine performance and inefficiency⁵.

Due to the constant connection between the camshaft and the crankshaft, engine manufacturers must tune their camshaft design to one ideal operating point where the engine will be most efficient and accept inefficiency at other operating points. However, these issues can be solved by disconnecting the actuation of the valves from the position of the engine. The electromechanical valvetrain of this project does just this. By independently controlling the engine's valves and allowing varied timing schemes to be implemented to optimize engine efficiency, the electromechanical valvetrain can be tuned for maximum efficiency at any engine operating point.

Figure 4 shows, in blue, the lift of an engine valve controlled by a typical cam, and in red, the path of a valve controlled by a laboratory model of a camless valvetrain. This figure shows how the primary improvement of the camless valvetrain is its ability to open the valves much faster. This allows engine timing to be varied towards maximum efficiency. For example, the exhaust valve could be left closed longer at high engine speeds to allow complete combustion of the fuel charge before exhausting the cylinder. Additionally, an intake valve could be opened for a shorter period to take in a reduced fuel charge when the engine requires only low power. Furthermore, the engine could line up its exhaust and intake strokes continuously for maximally efficient overlap. Most of the issues with the camshaft-based valvetrain arise because the system requires engine manufacturers to choose one operating point for which to optimize the camshaft. This choice can be avoided by implementing a camless system, which can lead to greater efficiency and greater power output at all operating conditions.

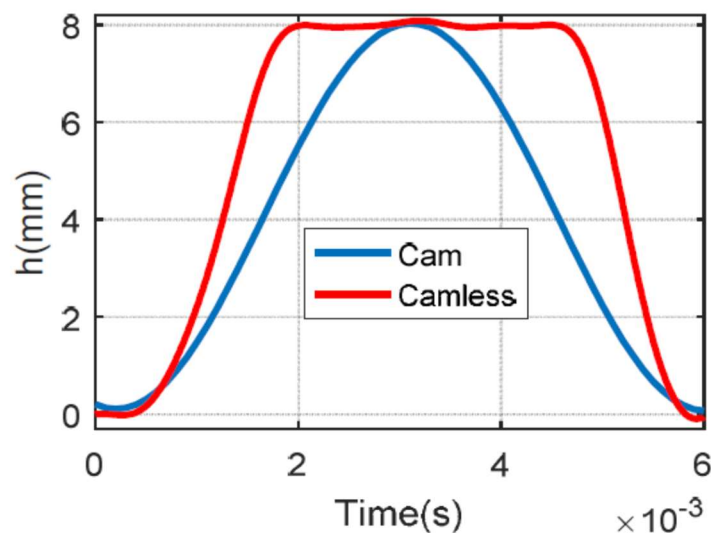

Figure 4: Comparison of Valve Position in Cam and Cam-less Systems⁶

2.3. Recent Valvetrain Design Innovations

Researchers and companies continue to work to improve the valvetrain. The most influential improvement in many years came in 1989 when Honda debuted the Variable Valve Timing and Lift Electronic Control (VTEC) system⁷. This system places both a high valve lift cam and a low valve lift cam in the engine for each valve and uses a hydraulic system to switch between cams as driving conditions change⁸. Some of the first VTEC engines were able to produce as much power as similar non-VTEC engines, but across a much wider range of engine speeds thanks to the ability to switch between cams⁷.

More recently, a highly innovative and camless engine has been demonstrated by the FreeValve company, a spin-off of high-performance car maker Koenigsegg. The FreeValve engine includes many improvements over traditional engines, but notably uses a, “Pneumatic-Hydraulic-Electric-Actuator” to replace the camshaft and cams. In 2016, a model of the FreeValve engine was introduced in a modified Qoros 3 hatchback and demonstrated a 47% increase in engine power, a 45% increase in torque and a 15% reduction in fuel consumption compared to a similar (1.6 liter turbocharged) engine⁹.

Recently, the Camcon company has also developed a camless engine. Camcon’s design uses electric rotary actuators to push open and closed valves. This engine has demonstrated a 7.5% increase in fuel economy with the Camcon system applied to just the intake valves¹⁰.

2.4. Environmental and Societal Impacts

Sustainability is a critical consideration in the design and utilization of any product. A primary motivation for this project is to improve a highly-utilized technology to increase the efficiency with which we utilize non-renewable resources. In 2017, transportation accounted for 29 percent of energy consumption in the United States, including 72 percent of the United States’ petroleum consumption. 92 percent of all transportation sector energy use was petroleum fueled¹¹. This shows how great a potential there is to create meaningful reduction in fossil fuel utilization by even small improvements in combustion engine technology.

It is currently estimated that fossil fuels, including gasoline, will run out within the next century due to over consumption¹². Improvement of existing combustion engines is therefore a bridge technology between the current state of use of combustion engines and the transition to electric or alternatively powered vehicles. Furthermore, by increasing the efficiency of engine products, the electromechanical valvetrain can benefit users economically.

3. ELECTROMECHANICAL VALVETRAIN DESIGN

The design phase of this project included definition of design criteria, brainstorming of possible solutions and final design selection using design criteria.

3.1. Design Considerations

To guide brainstorming of valvetrain designs, the general requirements of the system were defined. These design considerations are shown in Table 1. Each consideration was assigned a priority in contributing to a successful design. As shown, system safety is critically important and required. Also required of the design were functionality and accuracy. The remaining design considerations were used to guide the design brainstorming process.

Table 1: Design Considerations

Consideration	Description	Priority
Safety	System operation must not present new hazards to persons present during testing.	Essential
Functionality	System should be implemented to maintain an operable engine.	Essential
Reliability	System must be robust enough to provide several tests.	Essential
Manufacturability	Designed portions of the valvetrain must be manufacturable in the Shiley School of Engineering Shop.	Essential
Accuracy	Data collection systems should provide accurate data to the control system.	High
Maneuverability	System must be maneuverable for testing.	Medium
Cost	Project and components must not exceed proposed budget.	Medium
Operating Simplicity	Operation of the LabVIEW control system must be user friendly for future use.	Medium
Size and Storage	The final prototype must fit on and around the test setup table.	Low

3.2. Design Concepts

Alongside defining the design considerations, brainstorming of possible methods of actuating the engine valves without the camshaft was conducted. Shortly, three methods of valve actuation were identified, and valvetrain designs implementing these systems were drafted. These three systems were pneumatic, hydraulic and electric actuation. The proposed hydraulic and pneumatic systems were very similar in concept. Both options proposed using valves to let a fluid into a ram which would push down to open the engine valves. The hydraulic system would use a liquid hydraulic fluid while the pneumatic system would use compressed air as its working fluid. Figure 5 shows the hydraulic system concept.

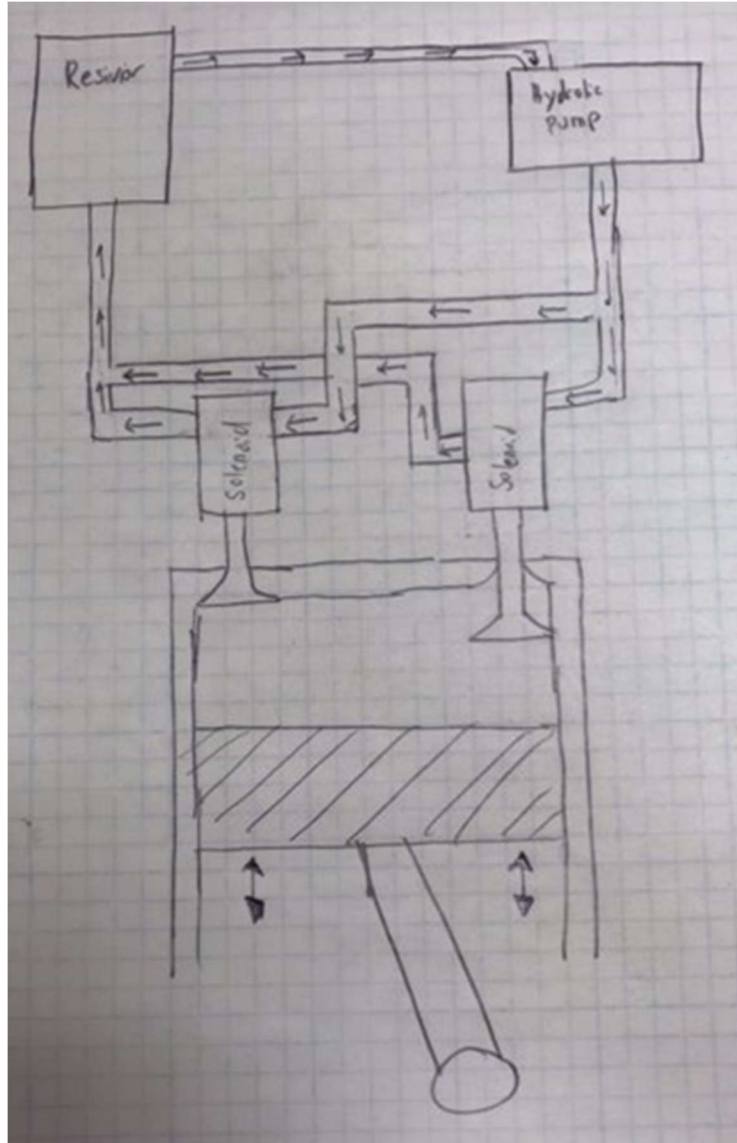

Figure 5: Hydraulic System Concept

The electric actuation system concept proposed using a high-speed and high-power motor to turn a cam which would push open the valve as the cams in the traditional valvetrain do. By turning the cams with independent electric motors this system would achieve faster actuation speeds and allow variable timing of the valves. Figure 6 shows the design of the electrical concept system.

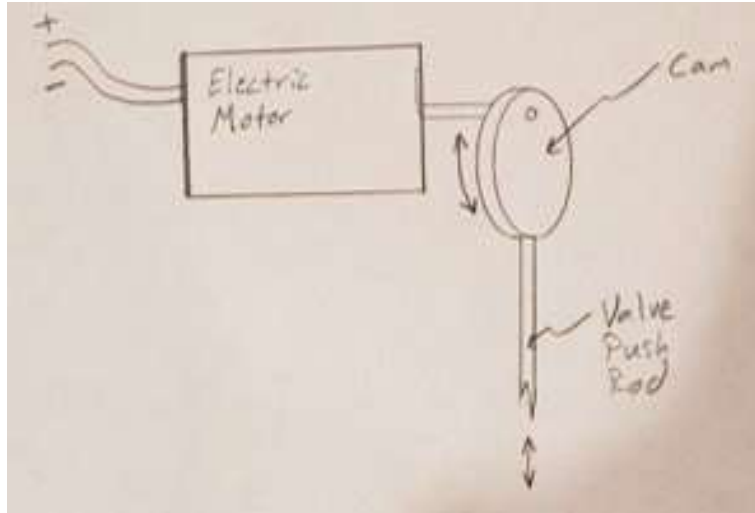

Figure 6: Electric System Concept

3.3. Design Criteria

After brainstorming, criteria that a successful electromechanical valvetrain system must meet were determined. These criteria were used in critical evaluation and comparison of the design concepts and were also established as the metrics for measurement of the effectiveness of the final design. The design criteria for this project are shown in Table 2. As shown, any design was required, at a minimum, to be constructed within the project budget, and was expected to maintain and improve engine performance characteristics.

Table 2: Design Criteria

Criteria	Quantity
Cost	Cost less than \$2,000
Power output	Equal to engine baseline value
Engine efficiency	Increase greater than or equal to 1% of baseline value
Engine speed	Allow operation within entire baseline speed range
Timeline	Constructed before April 1, 2019

3.4. Design Selection

The main consideration in selecting a final design was actuation speed. The Model 19 engine on which the electromechanical valvetrain was to be tested was known to produce its maximum power when operating around 3,000 RPM. At this speed, one stroke in the four stroke engine cycle lasts 10 milliseconds (0.01 seconds). Therefore, valve actuation speeds approaching one millisecond (ms) were desired, to maximize engine efficiency. This value was chosen because, for example, the intake stroke lasts just 10 ms, meaning the valve actuation system has a

maximum of 5 ms to fully open the valve and then immediately close it in 5 ms. In order to improve upon the existing camshaft-based system, much faster speeds were desired.

With actuation speed as the primary consideration, the electric concept was determined to be infeasible because a motor that could complete 180 degrees of rotation in milliseconds could not be found within the project budget. Additionally, the hydraulic concept was found to be unfeasible because a hydraulic valve that could respond on the millisecond time scale could not be found within the project budget. Therefore, when electric solenoid air valves were found which can fully open in as little as 0.45 ms, the pneumatic system was chosen for this project. The initial schematic of a camless valvetrain using pneumatic actuators is shown in Figure 7.

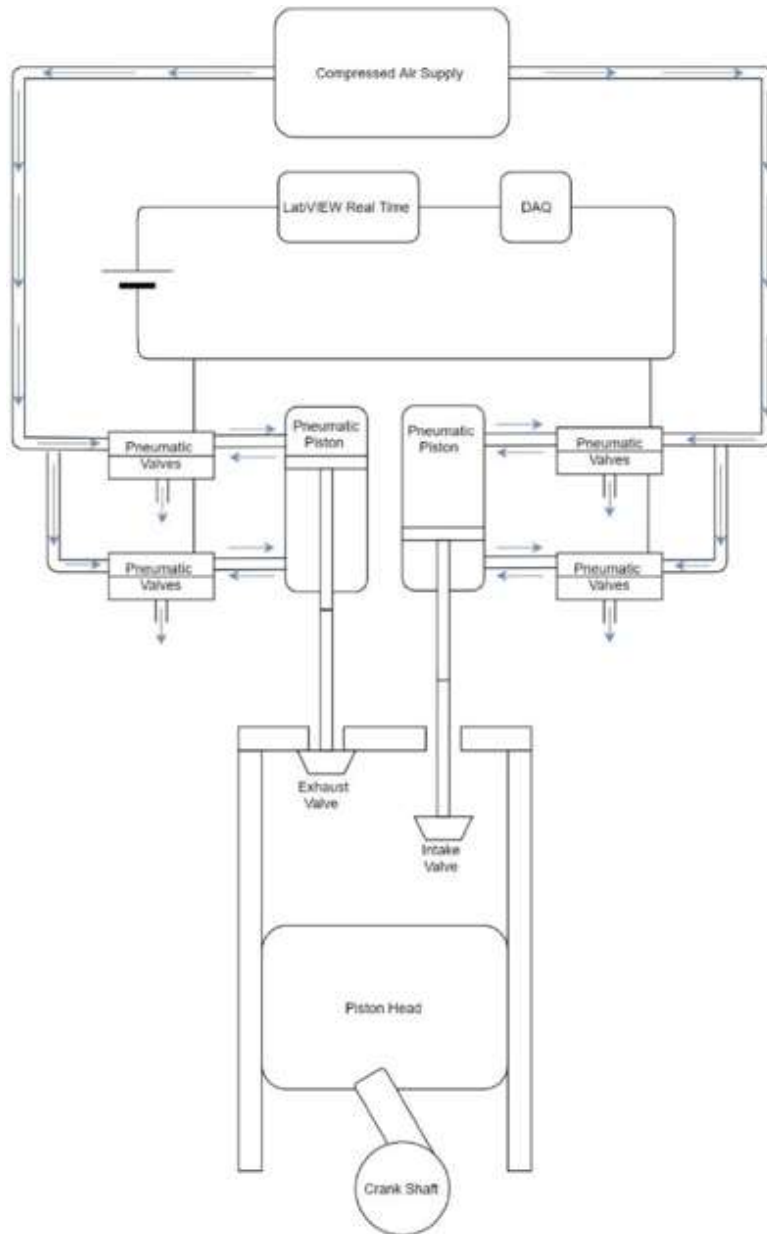

Figure 7: Initial Design of Pneumatically-Actuated Electromechanical Valvetrain

4. ELECTROMECHANICAL VALVETRAIN DEVELOPMENT

The chosen valvetrain design - pneumatic actuation of the valves using air-powered rams supplied by high-speed valves – was primarily chosen over other options because of the availability of cost-effective components which met the needs of this project. Specifically, SMC Corporation’s SX12 valves were chosen for this project because of their ability to fully open in as little as 0.45 ms and provide 100 liters per minute of air flow at 100 pounds per square inch (PSI) pressure. Both this speed, and other capabilities making these valves able to use the compressed air supplied in Shiley Hall at University of Portland made these valves perfect for this project. However, providing air flow quickly was only part of the challenge of this project. The actuation itself still needed to happen in less than 5 ms, as calculated above, to beat the existing system. The SX12 valve is shown in Figure 8.



Figure 8: SX12 Valve from SMC Corporation¹³

4.1. Pneumatic Actuation System Prototyping

Having chosen to pursue a pneumatic actuation system based on the SX12 valve, a value for extension time of a pneumatic ram supplied by these valves was needed. A basic pneumatic ram with a 0.25-inch stroke length (extension) was ordered, along with SX12 valves. A simple air flow block was fabricated to supply the ram and this prototype pneumatic actuation system was assembled (Figure 9). A prototype control system was also created in the LabVIEW (Laboratory Virtual Instrument Engineering Workbench) software package. More details of the LabVIEW control system development are given in section 4.2.

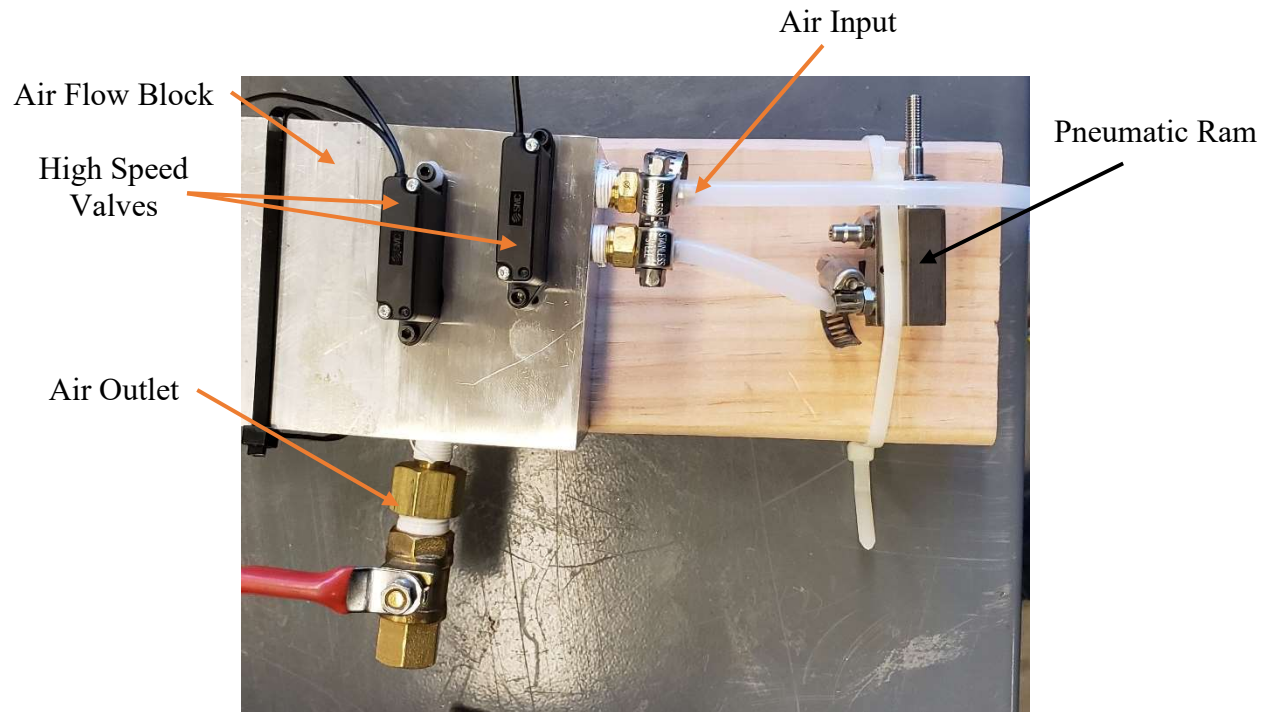

Figure 9: Prototype Pneumatic Actuation System

The pneumatic ram used in the test set-up shown in Figure 8 is a classic type ram. The inner workings of this type of ram are shown in Figure 10. This part produces linear motion when high pressure fluid is let into the cylinder behind the piston, forcing the piston and rod to extend. This actuator contains the pressure input behind the piston with a rubber bearing which is mounted on the piston and contacts the cylinder walls.

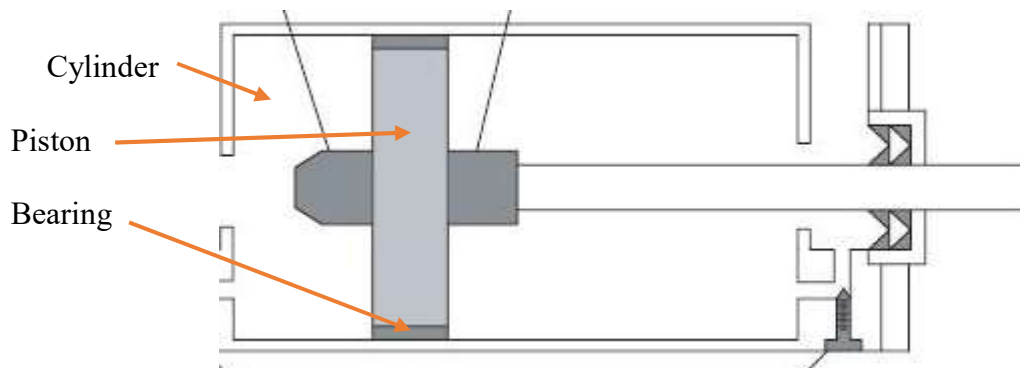

Figure 10: Schematic of Typical Fluid Actuator¹⁴

Using the test set-up shown above, it was determined that the basic pneumatic air cylinder extends its 0.25-inch stroke in $7 \text{ ms} \pm 1 \text{ ms}$ when supplied air by the high-speed valves of this project. This was determined using high speed video taken at 960 frames per second. As this

value was not fast enough, two options were considered for increasing the actuation speed of the system. It was determined that either the air pressure of the system could be increased, or the friction in the system could be decreased. To avoid exceeding the pressure rating of the valves, air-bearing rams made by the Airpot Corporation were determined to be the best next step in development of the pneumatic system. Figure 11 shows the parts which make up an air-bearing cylinder. Built with a bearing which does not reach the cylinder wall, this ram uses the flow of a small amount of air past the piston to create the ‘air bearing’ effect, allowing nearly frictionless motion¹⁵.

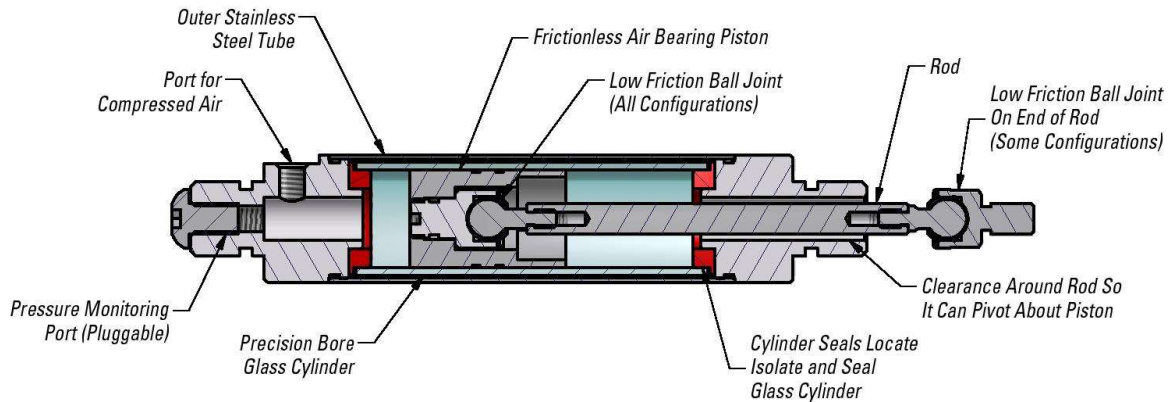

Figure 11: Airpot Corporation Airpel AB Pneumatic Ram Schematic ¹⁵

The Airpel AB air bearing cylinder was tested using the prototype set-up as in Figure 8 and was found to extend 0.3 inches (the actual distance the engine valves need to be moved) in approximately 3 ms. This meets the speed criteria of the valve actuation system (less than 5 ms beats the existing system) and therefore the Airpel air-bearing cylinders were chosen for the final design.

4.2. Control System Prototyping

4.2.1. Electrical System Requirements

The high-speed valves used in this project achieve their extremely low opening times using a large amount of power while they are opening, but then only require approximately 16 percent of that maximum power to hold the valve open. Changing the power supplied to a system is useful in many situations and one method of achieving this effect is called Pulse-Width Modulation (PWM). In this control method, higher and lower voltage can be supplied to a component by switching a high-voltage power supply on and off very quickly. For example, a 24-volt power supply only switched on half the time effectively provides 12 volts to a system. In fact, any lower voltage can be achieved simply by changing the amount of time the power supply is on. Figure 12 shows the PWM power signal that the valves of this project require to operate effectively. This figure shows how the valves expect high power to open initially, then lower power, achieved by switching the power supply, for the remainder of the time the valves should be on.



Figure 12: Pulse-Width Modulated Power Signal Required by High Speed Valves¹³

4.2.2. Control Software

For this project, high speed data reading and control signal writing is required. As briefly mentioned previously, the LabVIEW software package was chosen as a robust platform for this purpose. LabVIEW uses relatively inexpensive hardware modules to read data signals and output (write) data and control signals, and simulates the functions of signal analysis and processing tools which might otherwise require benchtop analysis tools or complex electrical circuits. LabVIEW uses a block-diagram based graphical user interface for building the sequences of virtual instruments and operations which make up a control system. Figure 12 shows the first LabVIEW code that was created for this project. This code was used to provide the PWM control signal to operate the high-speed valves on the prototype air flow block.

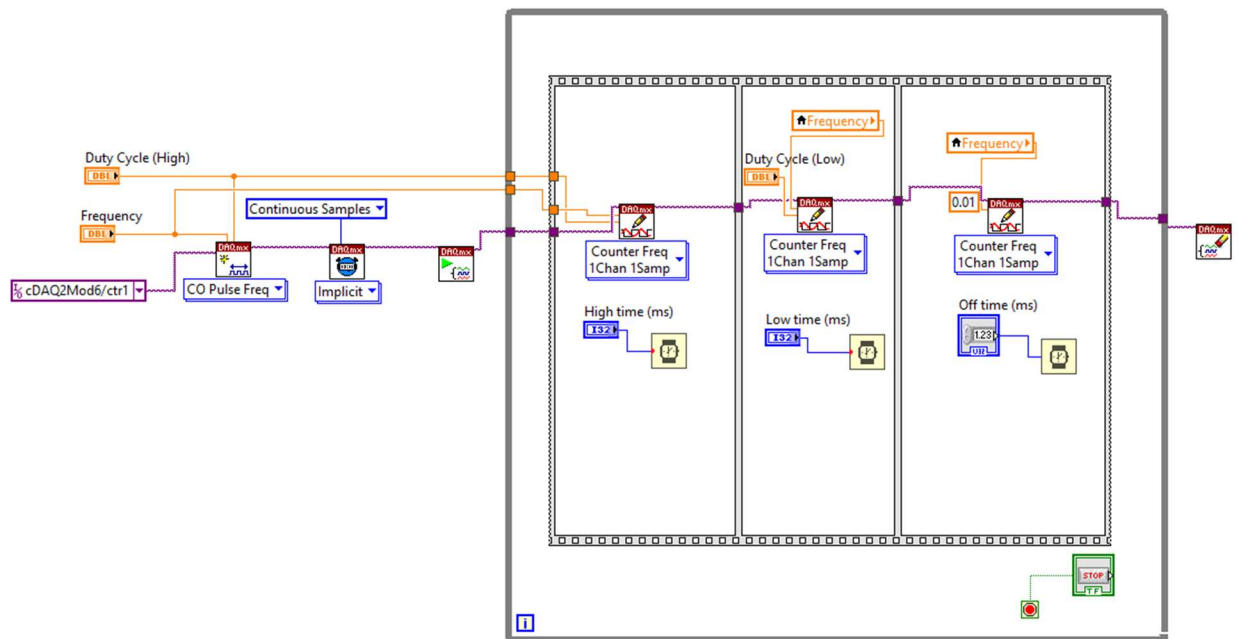

Figure 13: Prototype LabVIEW Control System Block Diagram

5. FINAL DESIGN

The final design of the electromechanical valvetrain is the combination of the previously documented components in a system which allows them to work together to operate the engine

valves to allow the engine to operate. This design includes the valve-actuation subsystem, electrical subsystem and software control system, each detailed below.

5.1. Air Flow Control System

To provide high pressure air to each high-speed valve and release this air from the rams when they need to retract, an air flow block was designed. Using channels cut into a block of aluminum, the high-speed valves mount on this block, and receive air from the high-pressure supply and provide air to each ram when they turn on. The air flow block designed and fabricated for this project is shown in Figure 14. This part was designed by the team using the computer-aided design (CAD) software SolidWorks and was fabricated by team members and the shop technician in the shop at the Shiley School of Engineering using the computer numerical controlled (CNC) mill. The CNC mill produces parts with dimensions correct to within 0.002 inches. This precision is far better than can be achieved on the manual (human operated) mill and allowed the team to create this part exactly as needed.



Figure 14: Air Flow Block

5.2. Valve Actuation Subsystem

The valve actuation subsystem integrates the high-speed valves which provide air to the air-bearing rams, the rams themselves, and an updated air flow block to provide air pressure to each necessary line. The system uses a rocker design so that one pneumatic ram opens, and another closes each engine valve (intake and exhaust). Figure 15 shows a CAD model of this system. The parts for this system were also fabricated using the Shiley School of Engineering's CNC mill, allowing precise control of dimensions to be sure the parts would fit exactly, and minimize friction.



Figure 15: Model of Rocker Valve Actuation System

When integrated with the high-speed air valves and mounted on the head of the engine in place of the rockers which were powered by cams in the old valvetrain, the air flow block and rocker system make up the valve actuation subsystem. Figure 16 shows the final assembly of the valve-actuation system.

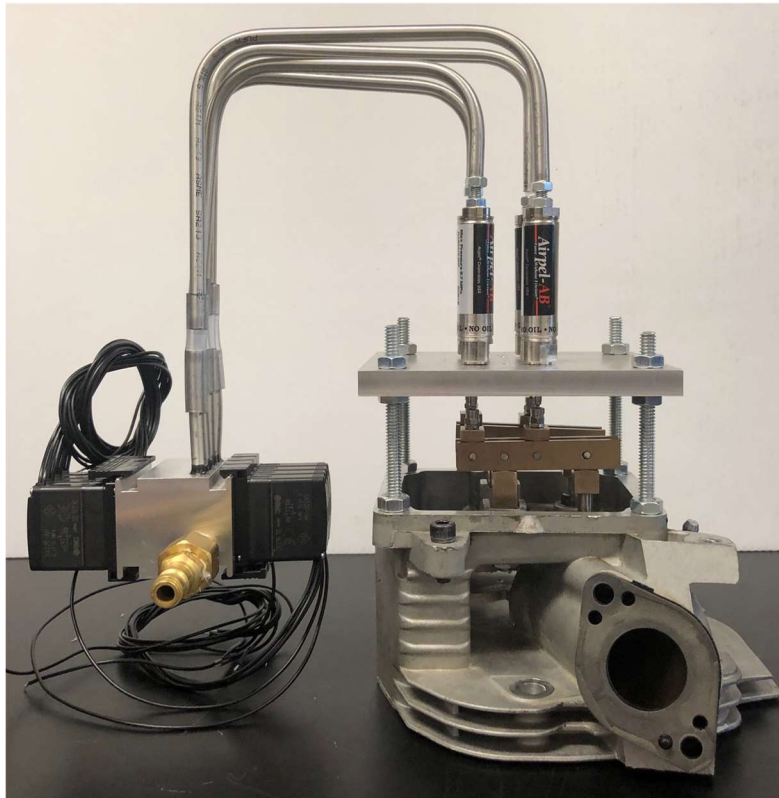

Figure 16: Final Valve Actuation System Assembly

5.3. Electrical System

The electrical system for this project also was developed through many iterations. Figure 17 shows the design which uses two high-speed switching electrical components (MOSFETs) to switch the power supply to provide the correct PWM power supply to the valves as commanded by PWM signals from LabVIEW.

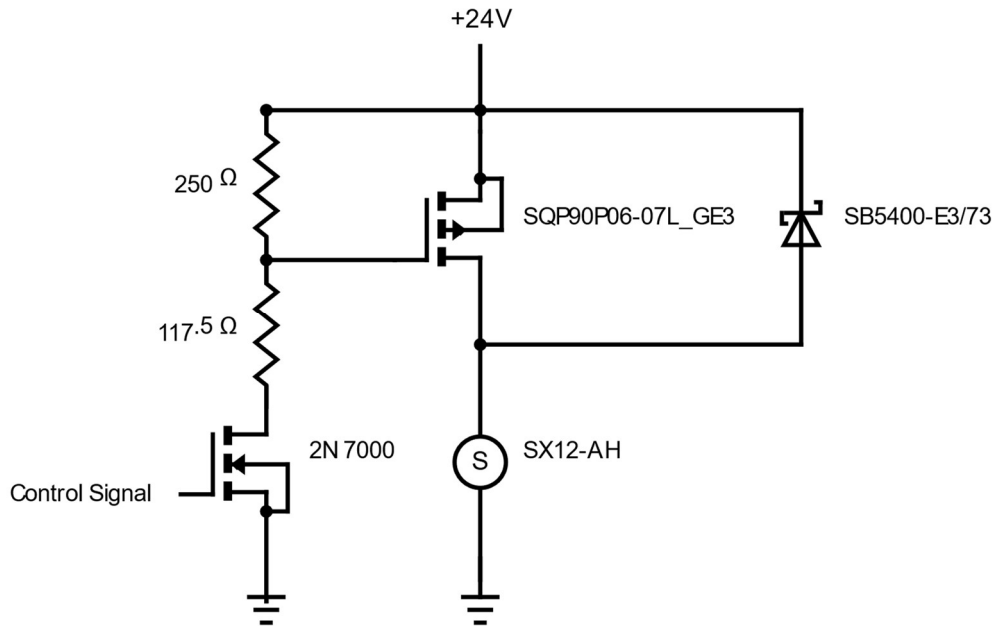

Figure 17: Electrical Circuit Diagram

6. CONCLUSIONS

In the final analysis, this camless electromechanical valvetrain system has the capability to improve and extend the usefulness of the internal combustion engine as a power source. By increasing the efficiency of existing engines this system reduces emissions and can help protect the environment as the engineering design work necessary to implement a fully renewable energy powered transportation sector is completed.

To determine the success of this project, the original design considerations and criteria were revisited. Exact operating characteristics of the new system will be published once final tuning of the electrical and control system is conducted, but the system should open engine valves in approximately 3 ms, beating the existing system by almost 2 ms at the highest engine speeds. The final design was also constructed well within the provided budget, with the facilities available at University of Portland, and within the existing size of a typical IC engine.

7. REFERENCES

- [1] "Internal Combustion Engine." Oxford Reference. Date of access 1 Dec. 2018, Web.
- [2] Bookspar.com. "Parts of I.C. Engine." Web. Accessed 26 Nov 2018.
<http://slideplayer.com/slide/4616097/15/images/11/www.bookspar.com%20%7C%20Website%20for%20Students%20%7C%20VTU%20NOTES%20%7C%20QUESTION%20APERS.jpg>
- [3] "Four-stroke Cycle." Encyclopedia Britannica. Web. Accessed 11 April 2019.
<https://www.britannica.com/technology/four-stroke-cycle>
- [4] Shetty, Krishnaraj Vishnu. "MBD Simulation on IC Engine Valve Train." Accessed 2 April 2019. <https://projects.skill-lync.com/projects/MBD-Simulation-on-IC-Engine-Valve-Train-93203>
- [5] Summit Racing Equipment. "The Scavenging Effect." Web. 12 March 2019. Accessed 1 April 2019. https://help.summitracing.com/app/answers/detail/a_id/4794
- [6] Aliyu, Bhar. (2017). Comparative Analysis Between Cam and Cam-less Valve Actuating for Automotive System. Engineering and Applied Sciences. 2. 89. 10.11648/j.eas.20170205.12.
- [7] Kelly, Tim. "VTEC History & Technology – Wrenchin' [sic]." Super Street Network. 20 May 2009. Web. <http://www.superstreetonline.com/features/htup-0905-vtec-history-and-technology/>
- [8] Honda Worldwide, Inc. "The VTEC breakthrough as of October 2004: solving a century-old dilemma." Web. <https://world.honda.com/automobile-technology/VTEC/>
- [9] Koenigsegg. "Freevalve Technology." Web. Accessed Oct 2018. <http://www.freevalve.com/>
- [10] Stone, Roger et. Al. "Intelligent Valve Actuation – a Radical New Electro-Magnetic Poppet Valve Arrangement." 2017. 26th Aachen Colloquium Automobile and Engine Technology 2017. https://uploads-ssl.webflow.com/5bc092fb09114c67b715d393/5bc4c28cca81a9cd9882c60f_26th_Aachen_Colloquium_2017_Manuscript-IVA-Final.pdf
- [11] U.S. Energy Information Administration. "U.S. Energy Facts Explained." US Department of Energy. 16 May 2018. https://www.eia.gov/energyexplained/?page=us_energy_home
- [12] Ecotricity. "The End of Fossil fuels." Web. Accessed Oct 2018.
<https://www.ecotricity.co.uk/our-green-energy/energy-independence/the-end-of-fossil-fuels>.

- [13] SMC USA. "SX10, 2 Port High Speed Valve." Accessed 6 Oct. 2018.
<https://www.smcusa.com/products/SX10-2-Port-High-Speed-Valve~126506>
- [14] Hydraulic Schematic Troubleshooting. "Hydraulic Cylinder Cushioning." 5 May 2010.
http://www.hydraulicstatic.com/20100505_hydraulic-cylinder-cushioning.html
- [15] Airpot Corp. "Airpel-AB Air Bearing Cylinders." Accessed 11 Feb 2019.
<https://airpot.com/product-category/product-lines/pneumatic-actuation/airpel-ab-air-bearing-cylinders/>
- [16] Joseph Albright, Sam Colosimo, Dominic Ferrari and Anthony Pepe. "Senior Design Report Part 1 Team 9 SAE – Engine." Department of Mechanical Engineering University of Portland. 4 December 2017.