

August 2019

The Life Course Impacts of Adverse Childhood Experiences on Individuals' Psychosocial Functioning

Lixia Zhang
University of Wisconsin-Milwaukee

Follow this and additional works at: <https://dc.uwm.edu/etd>



Part of the [Social Work Commons](#)

Recommended Citation

Zhang, Lixia, "The Life Course Impacts of Adverse Childhood Experiences on Individuals' Psychosocial Functioning" (2019). *Theses and Dissertations*. 2275.
<https://dc.uwm.edu/etd/2275>

This Dissertation is brought to you for free and open access by UWM Digital Commons. It has been accepted for inclusion in Theses and Dissertations by an authorized administrator of UWM Digital Commons. For more information, please contact open-access@uwm.edu.

THE LIFE COURSE IMPACTS OF ADVERSE CHILDHOOD EXPERIENCES ON
INDIVIDUALS' PSYCHOSOCIAL FUNCTIONING

by

Lixia Zhang

A Dissertation Submitted in
Partial Fulfillment of the
Requirements for the Degree of

Doctor of Philosophy
in Social Work

at

The University of Wisconsin-Milwaukee

August 2019

ABSTRACT
THE LIFE COURSE IMPACTS OF ADVERSE CHILDHOOD EXPERIENCES ON
INDIVIDUALS' PSYCHOSOCIAL FUNCTIONING

by

Lixia Zhang

The University of Wisconsin-Milwaukee, 2019
Under the Supervision of Professor Joshua P. Mersky

Introduction: Research has shown that adverse childhood experiences (ACEs) such as child maltreatment and household dysfunction are among the leading environmental causes of morbidity and mortality. Despite the proliferation of ACEs studies, many significant gaps in the literature remain. First, many ACEs studies have examined the physical health outcomes of older adults. To better understand the origins of disease and death, further research is needed that examines the effects of ACEs on mental health and behavioral health earlier in the life course. Second, although international interest in ACEs is on the rise, most ACE research has been conducted in the Western nations, few investigations have cross-validated the measurement of ACEs or examined the effects of ACEs in less developed countries. Third, this body of research has almost exclusively explored the connection between individuals' retrospective accounts of adversity and their own functioning. Few studies have used prospective data to test the intergenerational consequences of ACEs. Methods: This dissertation comprises three studies that addressed the above gaps. The first study used data from the Fragile Families and Child well-being study to explore the longitudinal and bidirectional relations between ACEs and child internalizing/externalizing problems. The second study used original data collected from over 1,000 rural Chinese young adults, to assess the cross-cultural validity of an ACE measure and test the effects of ACEs on psychological well-being in emerging adulthood. The third study used data from the Families and Children Thriving Study in Wisconsin to explore whether a mother's own exposure to

ACEs would affect the socio-emotional development of her offspring. Results: Over 80% of participants had at least 1 ACE in the three studies. The first study revealed that there was bidirectional relationship between ACEs and child internalizing/externalizing problems, although the relationship was not always significant from early childhood through middle adolescence. The second study demonstrated that ACEs were significantly related with Chinese young adults' psychological problems. The third study highlighted that there was significant relationship between maternal ACEs and children's socio-emotional problems. The relationship was also mediated by maternal mental health problems and adult adversity. Conclusions: ACEs were prevalent among economically disadvantaged populations. ACEs also impacted individuals' psychosocial outcomes from early childhood through next generation. Results from the dissertation research may guide evidence-based and culturally sensitive prevention and intervention efforts in both China and the United States.

DEDICATION

To my father, Qingxin Zhang, who teaches me how to live and learn.

To my husband, Guang Gao, who offers me endless love and support.

TABLE OF CONTENTS

Chapter 1	Introduction 1
Chapter 2	Bidirectional Relations Between Adverse Childhood Experiences and Internalizing/Externalizing Problems from Early Childhood to Middle Adolescence 15
Chapter 3	Adverse Childhood Experiences and Psychological Well-being in a Rural Sample of Chinese Young Adults 50
Chapter 4	Intergenerational Effects of Maternal Adversity on Child Socio-Emotional Development 83
Chapter 5	Conclusion 108
Appendix A	Measure of ACEs in FFCWS 115
Appendix B	Measure of Child Internalizing/Externalizing Problems in FFCWS 122
Appendix C	Model Fit Index 126
Curriculum Vitae	127

LIST OF FIGURES

- Figure 1 Random Intercept Cross-Lagged Panel Model (RI-CLPM) 46
- Figure 2 Mediation Analysis Model Linking Maternal ACEs to Child Problem Through Maternal Adult Adversity and Mental Health Problem 107

LIST OF TABLES

Table 1	Baseline Demographic Information 46
Table 2	Prevalence of Adverse Childhood Experiences 47
Table 3	Adverse Childhood Experiences: Correlations and Descriptive Statistics 47
Table 4	Child Internalizing/Externalizing Problems: Correlations 48
Table 5	Results of Random Intercept Cross-Lagged Panel Model 49
Table 6	Description of Study Measures 80
Table 7	Prevalence of ACEs among Chinese Young Adults 81
Table 8	Multivariate Model Results 82
Table 9	Description of Study Variables 105
Table 10	Correlations Between Childhood Adversity, Adulthood Adversity, Mother Mental Health Problems, and Child's Problem and Competence Outcomes 106
Table 11	Regression Analysis of the Effects of Maternal Childhood Adversity on Child's Problem and Competence Outcomes 107

ACKNOWLEDGMENTS

I am deeply grateful to many people who provided guidance, assistance, encouragement, support, and love during the journey of my doctoral program. First and foremost, I would like to extend my sincere gratitude to my advisor, Dr. Joshua Mersky, for his insightful advice and constant encouragement over the past four years. His marvelous thinking style and challenging comments on my work have shaped my intelligence and skills as a social work researcher for the long run.

I would also like to thank all my committee members. Dr. Steven McMurtry, I can never thank you enough for your endless support and encouragement over these years. Dr. Gwat-Yong Lie once joked that you were protecting me like a father protecting his daughter. Dr. Lie was right. Dr. James “Dimitri” Topitzes, you are a wonderful example that I want to follow. I truly feel grateful for your infinite humanity, warmth and support. Dr. Susan Rose, thank you for showing me how to be an outstanding female scholar in the academic world. I will never forget your smile, grace and warmth. Dr. Bo Zhang, thank you for your great guidance for my dissertation, especially the methodology part.

Other faculty members and administrative staff also have contributed to my dissertation and doctoral program journey. I thank Dr. Michael Brondino who has equipped me with significant statistical knowledge and skills to advance my dissertation. I also thank Dr. Stan Stojkovic, Dr. Gwat-Yong Lie, Dr. David Pate, Dr. Laura Otto-Salaj, Dr. Nancy Rolock, Dr. Lisa Berger, Dr. Linda Britz, Dr. Yura Lee, and Dr. Chienti Lee, for their priceless support, advice and encouragement during my Ph.D. study. In addition, I’d like to acknowledge our administrative staff: Mary Heller, Quinn Cory, and Alissa Mathison for their professionalism, warmth, and helpfulness.

The journey of Ph.D. program is like a marathon. I wouldn’t have reached the finish line without the friendship and support from my dear fellow Ph.D. students: Rebekah Johnson,

Daria Muller, Katelyn Blair, Nicole Robinson, and Laura Voith. My life-long friends and sisters, thanks for sharing the joy and tears with me through the long process.

I am extremely indebted to my families: my father (Qinxin Zhang), my mother (Shimei Liu), my sisters (LiLi and XiaoDong), and my brother (Tao Zhang), for their unconditional love and support. Special thanks go to my husband, Guang Gao. You are the light in my life. To my dear son, Brady Gao, who makes my life so joyful and hopeful. I love you forever and ever.

Last, I would also like to extend my gratitude to the Graduate School of University of Wisconsin-Milwaukee, which provided me the Distinguished Dissertation Fellowship for my dissertation research. My sincere thanks and respect go to the study participants in the Fragile Families and Child Wellbeing Study (FFCWS), Families and Children Thriving (FACT) Study, and China ACEs and Wellbeing Study. May social change make their life better and better.

CHAPTER 1

Introduction

Adverse childhood experiences (ACEs) include experiences of abuse and neglect and exposure to various forms of household dysfunction such as domestic violence, parental mental illness, substance abuse, incarceration and divorce/separation. More than two decades of research has led to growing consensus that ACEs are a major public health problem. Increasingly, the field has landed on the conclusion that ACEs and other sources of toxic stress in childhood are major drivers of poor health outcomes over the life course.

Much of the early evidence on ACEs was generated by the seminal Adverse Childhood Experiences Study, a well-known investigation of over 17,000 individuals who received medical care from 1995 to 1997 in San Diego, California. More than 200 publications have emerged from analyses of this dataset, yielding significant contributions to the knowledge base. For one, we have learned that ACEs are prevalent; more than half of the study participants reported at least one ACE (Felitti et al., 1998). These findings have been replicated by a large body of research with nationally representative samples (Green et al., 2010; Merrick, Ford, Ports, & Guinn, 2018).

Second, the Adverse Childhood Experiences Study shifted researchers' attention from single forms of childhood adversity to multiple and accumulating levels of adversity (Nurius, Green, Logan-Greene, & Borja, 2015). It is now understood that ACEs usually co-occur; approximately 38% of the participants in the Adverse Childhood Experiences Study reported that they had been exposed to at least two types of ACEs (Centers for Disease Control and Prevention, Kaiser Permanente, 2016). These findings have been replicated consistently by other studies (e.g., Green et al., 2010; Merrick et al., 2018; Mersky, Topitzes, & Reynolds, 2013). Thus, one of the contributions of ACE research is that it has unified disparate strands of literature that have historically been held separate. A long line of research has documented the impact of specific types of childhood adversity, such as physical abuse and neglect (Malinosky-Rummell & Hansen, 1993; Prino & Peyrot, 1994), sexual abuse (Briere & Runtz, 1998; Mullen,

Martin, Anderson, Romans, & Herbison, 1993), and exposure to domestic violence (Sternberg et al., 1993). However, adversities are often interrelated. To illustrate, children who are raised in households where domestic violence is present are at an elevated risk of being maltreated (Herrenkohl, Sousa, Tajima, Herrenkohl, & Moylan, 2008).

Third, the Adverse Childhood Experiences Study demonstrated that greater exposure to childhood adversity increases the risk of poor physical health, mental health, and behavioral health outcomes over the life course (e.g., Anda et al., 2002; Dube et al., 2001; Felitti et al., 1998). More specifically, there is often a dose-response relationship between ACE exposure and the likelihood of poor outcomes (Felitti et al., 1998). That is, as the number of reported ACEs increases, so does the risk of deleterious health consequences. A burgeoning body of research has replicated these findings with different sample populations and an array of health-related outcomes (Hughes et al., 2017; Kalmakis & Chandler, 2015). This body of research has contributed to paradigm shift in our understanding of health and disease across the lifespan (Shonkoff et al., 2012). That is, ACEs research has significant implications for the everyday practice of medicine and psychiatry, given that many health and mental health problems in later life can be tracked back to experiences that occur in childhood (Felitti, 2002).

Despite the proliferation of ACE studies over the past two decades, there are still significant research gaps that need to be addressed. First, many ACE studies have examined the health outcomes of adults. To better understand the origins of disease and death, further research is needed that examines the effects of ACEs on mental health and behavioral health earlier in the life course. Second, most ACE research has been based on adults' retrospective accounts of childhood adversity. Prospective, longitudinal research is needed to better understand the effects and mechanisms through which ACEs alter development and functioning over time. Third, most ACE research has been conducted in the United States and other Western nations. Although international interest in ACEs is on the rise, few investigations

have cross-validated the measurement of ACEs or examined the effects of ACEs in less developed countries. Finally, ACE studies have almost exclusively explored the connection between individuals' accounts of adversity and their own functioning. Despite longstanding speculation that adversity and trauma can have intergenerational consequences, the literature supporting this hypothesis remains underdeveloped.

The Current Dissertation Research

This dissertation comprises three studies that aim to address the above research gaps. The first study is a prospective, longitudinal investigation of the bidirectional relations between ACEs and child externalizing/internalizing problems. Data derived from the Fragile Families and Child Wellbeing Study (FFCWS), a cohort study of 4,898 children born between 1998 and 2000 in the U. S. A random intercept cross-lagged panel model was fit to estimate the reciprocal relationship between ACEs and internalizing/externalizing symptoms from early childhood through mid-adolescence. The study findings may help identify particular age points when ACEs may significantly impact child internalizing/externalizing problems, and when child internalizing/externalizing problems may significantly increase later exposure to ACEs. Such findings may also be used to optimize the timing of prevention and intervention programs and to target those strategies to populations that may benefit the most. Two main research questions were addressed in this study:

1. Does earlier exposure to ACEs increase the risk of later child internalizing/externalizing problems in early childhood, middle childhood, and adolescence?
2. Do earlier child internalizing/externalizing problems also have impacts on the trajectories of children's ACEs exposure from early childhood through middle adolescence?

The second study aimed to assess the prevalence of conventional ACEs and other potential adversities, and test associations between cumulative exposure to ACEs and psychological functioning in a sample of 1,019 Chinese young adults. A web-based survey

was used to gather data on participants' childhood adversities and health outcomes.

Descriptive analyses were completed to describe the prevalence of conventional ACEs and other new adversities. Multivariate regression analysis was applied to assess the associations between cumulative exposure to ACEs and psychological functioning in early adulthood. The study findings may help generate new knowledge about the cross-cultural validity of a new ACEs measure. Study outcomes may also help translate evidence into culturally appropriate prevention and intervention policies and programs in China. The study answered the following research questions:

1. What is the prevalence of conventional ACEs and other potential adversities in a sample of Chinese youth?
2. Does exposure to a greater number of ACEs increase the risk of poor psychological outcomes among Chinese youth?

The third study aimed to test if mothers' ACEs increase her children's risk of poor socio-emotional outcomes, and whether the effects of childhood adversity are mediated by mothers' experiences of adult adversity and mental health difficulties. The study sample includes 498 mothers with children aged 12-36 months who participated in the Families and Children Thriving (FACT) Study, a longitudinal investigation into the health and well-being of at-risk families in Wisconsin who received home visiting services. Multiple regression models were performed to assess associations between mothers' ACEs' scores and their children's socio-emotional development. Path analysis was also applied to assess whether mothers' mental health problems and adult adversity mediated the association between maternal ACEs and children's socio-emotional outcomes. The study findings underscore the need for early intervention and support for women who have endured significant childhood adversity and adulthood adversity. Study results also have implications for designing intervention strategies that can address maternal trauma and children's socio-emotional problems. This study also

examined two main research questions:

1. Is there an association between the number of ACEs a mother endured and her child's risk of socio-emotional problems?
2. Do mothers' self-reported mental health problems and cumulative adult adversity mediate the association between mothers' ACE scores and their children's socio-emotional problems?

Altogether, using different samples and methods, the three dissertation studies addressed significant research gaps in the literature. Results of the current dissertation generated new knowledge about the prevalence and sequelae of childhood adversity, and help to promote evidence-informed and culturally appropriate prevention and intervention services.

Theoretical Foundation

Three theoretical perspectives provide theoretical rationale for this dissertation: social determinants of health, life course perspective and developmental psychopathology perspective. Each perspective provides a conceptual foundation for scientific inquiry into ACEs generally and the dissertation research questions specifically.

Social Determinants of Health

The social determinants of health (SDoH) framework provides great insights into a better understanding of how social conditions decisively influence health outcomes. It also reflects that health inequalities cannot be addressed without addressing social inequalities first. Comparing to other theories which focus on individual's health development (e.g., Life Course Perspective), SDoH framework explains health inequalities from a global and public health perspective. It suggests a number of broad directions for public health policies and programs to tackle health gaps and disadvantages. For example, reorient health care services and public health programs to reduce inequities, and institutionalize equity into health systems governance (WHO, 2011).

With regard to ACEs research, the SDoH framework provides several implications for

ACEs study. First, SDoH framework indicates that the distribution of ACEs in society is, to a great extent, socially determined. That is, the way our environments structured and the distribution of social resources and power greatly determine who is exposed to adversity and who is not. People who have better socioeconomic status and enjoy more resources and power, tend to have less adversities. Second, SDoH has implications for understanding which individuals and groups are more likely to adapt successfully to adversity. More advantaged populations may be better equipped to adapt successfully due to a greater richness of protective factors, including social support and economic stability, in their environments.

Third, the SDoH framework offers a new direction for expanding ACE research and advancing the measurement of ACEs. As the most widely used measure for childhood adversities, the original CDC ACEs scale focuses exclusively on child maltreatment and household dysfunction. However, researchers have become increasingly interested in examining other potential adversities that occur outside the home such as peer victimization and community violence (Finkelhor, Shattuck, Turner, & Hamby, 2013; Finkelhor, Shattuck, Turner, & Hamby, 2015; Mersky, Janczewski, & Topitzes, 2017). The SDoH framework indicates that researchers may also want to attend to how socioeconomic status and inequalities, such as extreme poverty and discrimination, may impact individuals' health outcomes. Enlightened by the SDoH framework, the second dissertation study and the third dissertation study both examined the traditional ACEs and also explored other potential adversities such as family financial hardship, food insecurity, homelessness, and discrimination.

Life Course Perspective

The life course perspective is another framework that can be applied to understand the origins of health. It focuses on understanding how early life experiences can contribute to health outcomes across the life span and potentially across generations (Braveman & Barclay, 2009).

The life course perspective is appropriate to guide ACEs research given that ACEs are salient early life experiences during sensitive periods and potential indicators of cumulative stress across life span. The tenets of life course perspective also have significant implications for ACEs research. First, the life course perspective posits that health is determined by the complex interaction of many different levels of factors. Thus, to better understand individuals' health and development, ACEs research also need to consider factors outside the family, such as genetic factors, biological factors, community factors and societal factors. Second, the life course perspective recognizes that health disparities are the result of recurring interactions between risk and protective factors. Future ACEs research should assess whether protective factors, such as social support, buffer against the negative effect of adversities. Third, the life course perspective emphasizes the adverse events happened during critical period may have lifetime effects on individual's health. ACEs research has illuminated that early adversities undermine adult health and well-being. But less is known about the underlying pathways that link ACEs to these later-life health consequences. The life course perspective can be applied to help uncover how health trajectories are influenced by ACEs across childhood, adolescence, adulthood and even next generation. Under the guidance of life course perspective, the first dissertation study examined how ACEs would impact the trajectories of children's internalizing/externalizing problems from early 3 years old through 15 years old.

Developmental Psychopathology

Developmental psychopathology is an evolving interdisciplinary field that exerts a major impact on the study of individuals with high-risk conditions and psychological health problems (e.g., Cicchetti, 1990; Cicchetti & Cohen, 1995; Cicchetti & Dawson, 2002). It attends to how the interaction between nature and nurture influences the pathways by which normal and pathological, adaptive and maladaptive developmental outcomes emerge (Cicchetti, 1990; Cicchetti & Cohen, 1995; Cicchetti & Dawson, 2002; Cicchetti & Toth, 2009).

Developmental psychopathology can also provide a theoretical support for future ACEs research. First, developmental psychopathology suggests that ACEs research can help us have a better understanding of the normal development through studying the pathology caused by ACEs. At the same time, the study of how normal development unfolds in an average expected environment can help to inform the study of how ACEs and other environmental risks lead to maladaptation. Moreover, the concepts of equifinality suggests that although individuals who exposed to ACEs may have similar health problems, their developmental trajectories may be very different, while the concept of multifinality indicates that even individuals experience the same adversities, they may have different health results. Last, developmental psychopathology illustrates the organizational stages of human development and posits that early disturbances may harm later development systems. Thus, it can be applied to elucidate the mechanisms that cause developmental pathways to diverge toward unwanted outcomes. Thus, in addition to examining the deleterious consequences of ACEs, developmental psychopathology also requires to explore the underlying mechanisms (e.g., cognitive; socio-emotional) through which ACEs leads to these consequences. With regard to the third dissertation study, developmental psychopathology can help figure out the mechanisms through which ACEs impact mothers' well-being and the next generation's well-being.

Conclusion of Theoretical Perspectives

To conclude, social determinants of health, the life course perspective and developmental psychopathology are complementary conceptual frameworks that provide theoretical support for ACEs research. Research on the social determinants of health has implication for recognizing that the distribution of ACEs in society is not random and is, to some degree, socially determined. In addition, because social determinants research has shown that health and well-being is impacted by broad ecological forces, providing a rationale for expanding the measurement of ACEs to include other social and economic indicators of risk. The life course

perspective is also appropriate to guide ACEs research, since ACEs are early life experiences during sensitive periods and potential indicators of cumulative stress over lifetime. Finally, developmental psychopathology will assist ACEs researchers in exploring the underlying mechanisms through which ACEs lead to different health outcomes.

Summary of this Dissertation

This dissertation mainly consists of five chapters. Chapter One is the introduction section, which provides a review, and integrative synthesis of literature that is germane to ACE research along with gaps that require further scholarly attention. It also illustrates the three dissertation studies that address significant research gaps. Finally, it reviews three theoretical perspectives that can provide theoretical rationale for ACE research. Chapter Two is the first dissertation study: *Bidirectional Relations Between Adverse Childhood Experiences and Internalizing/Externalizing Problems from Early Childhood to Middle Adolescence*. Chapter Three is the second dissertation study: *Adverse Childhood Experiences and Psychological Well-being in a Rural Sample of Chinese Young Adults*. Chapter Four is the third dissertation study: *Intergenerational Effects of Maternal Adversity on Child Socio-Emotional Development*. Chapter Five is the conclusion section, which summarizes the findings of the three dissertation studies and highlights the implications for practice, research, and policy.

References

- Anda, R. F., Whitfield, C. L., Felitti, V. J., Chapman, D. P., Edwards, V. J., Dube, S. R., & Williamson, D. F. (2002). Adverse childhood experiences, alcoholic parents, and later risk of alcoholism and depression. *Psychiatric Services, 53*, 1001-1009.
- Bethell, C. D., Newacheck, P., Hawes, E., & Halfon, N. (2014). Adverse childhood experiences: assessing the impact on health and school engagement and the mitigating role of resilience. *Health Affairs, 33*(12), 2106-2115.
- Braveman, P., & Barclay, C. (2009). Health disparities beginning in childhood: A life course perspective. *Pediatrics, 124*(3), 163-175.
- Briere, J., & Runtz, M. (1998). Symptomatology associated with childhood sexual victimization in a non-clinical sample. *Child Abuse & Neglect, 12*, 51-59.
- Centers for Disease Control and Prevention, Kaiser Permanente. (2016). *The ACE Study Survey Data* [Unpublished data]. Atlanta, GA: U.S. Department of Health and Human Services, Center for Disease Control and Prevention. Retrieved from: <https://www.cdc.gov/violenceprevention/acestudy/about.html>
- Cicchetti, D. (1990). Developmental psychopathology: Reactions, reflections, projections. *Developmental Review, 13*, 471-502.
- Cicchetti, D., & Cohen, D. J. (1995). *Developmental psychopathology: Theory and method*. New York: John Wiley & Sons.
- Cicchetti, D., & Dawson, G. (2002). Multiple levels of analysis [Special issue]. *Development and Psychopathology, 5*(4), 497-774.
- Cicchetti, D., & Toth, S. L. (2009). The past achievements and future promises of developmental psychopathology: The coming age of a discipline. *Journal of Child Psychology and Psychiatry, 50*, 16-25.

- Dube, S. R., Anda, R. F., Felitti, V. J., Chapman, D. P., Williamson, D. F., & Giles, W. H. (2001). Childhood abuse, household dysfunction, and the risk of attempted suicide throughout the life span: Findings from the Adverse Childhood Experiences Study. *Pediatrics, 111*, 564-572.
- Felitti, V. J. (2002). The relationship of adverse childhood experiences to adult health: Turning gold into lead. *Zeitschrift Fur Psychosomatische Medizin und Psychotherapie, 48*(4), 359-369.
- Felitti, V. J., Anda, R. F., Nordenberg, D., Williamson, D. F., Spitz, A. M., Edwards, V., Koss, M. P., & Marks, J. S. (1998). Relationship of childhood abuse and household dysfunction to many of the leading causes of death in adults: The Adverse Childhood Experiences (ACE) Study. *American Journal of Preventive Medicine, 14*(4), 245-258.
- Finkelhor, D., Shattuck, A., Turner, H., & Hamby, S. (2013). Improving the adverse childhood experiences study scale. *JAMA Pediatrics, 167*, 70-75.
- Finkelhor, D., Shattuck, A., Turner, H., & Hamby, S. (2015). A revised inventory of adverse childhood experiences. *Child Abuse & Neglect, 48*, 13-21.
- Green, J. G., McLaughlin, K. A., Berglund, P. A., Gruber, M. J., Sampson, N. A., Zaslavsky, A. M., & Kessler, R. C. (2010). Childhood adversities and adult psychiatric disorders in the national comorbidity survey replication I: associations with first onset of DSM-IV disorders. *Archives of General Psychiatry, 67*(2), 113-123.
- Herrenkohl, T. I., Sousa, C., Tajima, E. A., Herrenkohl, R. C., & Moylan, C. A. (2008). Intersection of child abuse and children's exposure to domestic violence. *Trauma, Violence, & Abuse, 9*(2), 84-99.
- Hughes, K., Bellis, M. A., Hardcastle, K. A., Sethi, D., Butchart, A., Mikton, C., ... & Dunne, M. P. (2017). The effect of multiple adverse childhood experiences on health: a systematic review and meta-analysis. *The Lancet Public Health, 2*(8), e356-e366.

- Kalmakis, K. A., & Chandler, G. E. (2015). Health consequences of adverse childhood experiences: A systematic review. *Journal of the American Association of Nurse Practitioners*, 27(8), 457-465.
- Malinosky-Rummell, R., & Hansen, D. J. (1993). Long term consequences of childhood physical abuse. *Psychological Bulletin*, 114, 68-79.
- Merrick, M.T., Ford, D.C., Ports, K. A., & Guinn, A. S. (2018). Prevalence of Adverse Childhood Experiences From the 2011-2014 Behavioral Risk Factor Surveillance System in 23 States. *JAMA Pediatrics*, 172(11), 1038-1044.
- Mersky, J. P., Janczewski, C. E., & Topitzes, J. (2017). Rethinking the measurement of adversity: Moving toward second-generation research on adverse childhood experiences. *Child Maltreatment*, 22(1), 58-68.
- Mersky, J. P., Topitzes, J., & Reynolds, A. J. (2013). Impacts of adverse childhood experiences on health, mental health, and substance use in early adulthood: A cohort study of an urban, minority sample in the U.S. *Child Abuse & Neglect*, 37, 917-925.
- Mullen, P. E., Martin, J. L., Anderson, J. C., Romans, S. E., & Herbison, G. P. (1993). Childhood sexual abuse and mental health in adult life. *The British Journal of Psychiatry*, 163(6), 721-732.
- Nurius, P. S., Green, S., Logan-Greene, P., & Borja, S. (2015). Life course pathways of adverse childhood experiences toward adult psychological well-being: A stress process analysis. *Child Abuse & Neglect*, 45, 143-153.
- Prino, C. T., & Peyrot, M. (1994). The effect of child physical abuse and neglect on aggressive withdrawn, and prosocial behavior. *Child Abuse & Neglect*, 18(10), 871-884.

- Shonkoff, J. P., Garner, A. S., Siegel, B. S., Dobbins, M. I., Earls, M. F., McGuinn, L.,...& Wood, D. L. (2012). The lifelong effects of early childhood adversity and toxic stress. *Pediatrics*, *129*(1), 232-246.
- Sternberg, K. J., Lamb, M. E., Greenbaum, C., Cicchetti, D., Dawud, S., Cortes, R. M., Krispin, O., & Lorey, F. (1993). Effects of domestic violence on children's behavior problems and depression. *Developmental Psychology*, *29*(1), 44-52.
- WHO. (2011). *Closing the gap: Policy into practice on social determinants of health*. Rio de Janeiro: WHO World Conference on Social Determinants of Health.

CHAPTER 2

Bidirectional Relations between Adverse Childhood Experiences and Internalizing/Externalizing Problems from Early Childhood to Middle Adolescence

Abstract

Research has shown that adverse childhood experiences (ACEs) increase the risk of poor health and well-being, yet less is known about the pathways through which these life outcomes emerge. For instance, prospective, longitudinal research into the link between ACEs and the trajectories of internalizing/externalizing problems is limited. Moreover, no longitudinal study has investigated whether children's internalizing/externalizing problems also increase their risk of adverse experiences over time. Therefore, the main purpose of this study is to explore bidirectional relations between adverse childhood experiences and internalizing/externalizing trajectories in a sample of low-income children. This study is a secondary data analysis of the Fragile Families and Child Wellbeing Study (FFCWS) dataset. The FFCWS is a birth cohort study of 4,898 children born between 1998 and 2000. FFCWS families were interviewed soon after their child's birth and again when the child was about 1, 3, 5, 9 and 15 years old. For the current study, data on the focal child's ACEs and internalizing/externalizing problems were primarily obtained through telephone and in-home interviews with the child's primary caregiver at years 3, 5, 9 and 15. Eight ACEs were measured in this study, including four types of maltreatment (physical abuse, emotional abuse, neglect, sexual abuse) and four types of household dysfunction (domestic violence, mental illness, substance abuse, incarceration). At each time point, ACEs were dichotomized and summed to produce an aggregate score ranging from 0 to 8. Caregiver ratings on the Child Behavior Checklist (CBCL) were used to measure children's internalizing and externalizing problems at year 3, 5, 9 and 15. Total scores of four problem subscales of the CBCL were included in this study: anxious/depressed problem, withdrawn problem, aggressive problem, and destructive/delinquent problem. A random intercept cross-lagged panel model was fit to examine the reciprocal relations between ACEs and child internalizing/externalizing problems while controlling for child gender as well as maternal

race/ethnicity, education, income, and age at childbirth. Descriptive analyses showed that roughly half of children were exposed to an ACE at each measurement time point. Estimates of cumulative incidence indicated that 85% of children endured at least one ACE from ages 3 to 15 years. Results from the random intercept cross-lagged panel model indicated that year 5 ACE scores significantly predicted year 9 anxious/depressed problems ($\beta=0.116$, $SE=0.030$, $p < 0.001$) and year 9 aggressive problems ($\beta=0.080$, $SE=0.036$, $p < 0.05$). Year 5 anxious/depressed problems also significantly predicted year 9 ACE exposure ($\beta=0.094$, $SE=0.024$, $p < 0.001$). From year 3 to year 9, ACEs also played a dominant role in the bidirectional relationship with internalizing/externalizing problems. That is, the effect of early ACEs on later internalizing/externalizing problems was greater than the effect of early internalizing/externalizing problems on later ACEs. The findings have implications for understanding the etiology and consequences of adversity as well as the design of prevention and intervention strategies.

Keywords: Adverse childhood experiences (ACEs), child internalizing/externalizing problems, longitudinal study, bidirectional relationship

Research has shown that exposure to early adversity can compromise lifelong and even intergenerational health and wellness (Felitti et al., 1998; Lê-Scherban, Wang, Boyle-Steed, Lee, & Pachter, 2018). Despite the proliferation of adverse childhood experiences (ACEs) studies over the last two decades, many significant gaps in the literature remain. For instance, most studies measure ACEs retrospectively, and no study has examined the trajectories of ACE exposure across different childhood stages. Moreover, although the influence of ACEs on adult health has been investigated for a long time, the proximal impact on child development is underdeveloped. For example, little is known about the effects of ACEs on the trajectories of internalizing and externalizing problems from early childhood to adolescence. Furthermore, few studies have explored potential bi-directional relations between ACEs and maladaptive outcomes. That is, just as ACEs may undermine children's functioning, children with internalizing and externalizing problems may be at risk of certain ACEs such as physical abuse. This study aimed to address these research gaps by investigating the trajectories of children's ACEs and internalizing/externalizing problems from early childhood to middle adolescence. This study also examines if exposure to ACEs predict poorer internalizing/externalizing problems over time, and if internalizing/externalizing problems also contribute to the exposure of ACEs in later life.

Impact of Childhood Adversity on Child Internalizing/Externalizing Problems

Children who display early internalizing/externalizing problems are at risk of poor outcomes in later life such as delinquency, psychiatric disorders, health risk behaviors, low academic achievement, and relationship difficulties with peers and parents (Coie & Dodge, 1998; Duncan, Claussens, & Engel, 2004; Fanti & Henrich, 2010; Keiley, Lofthouse, Bates, Dodge, & Pettit, 2003; Kovacs & Devline, 1998; Roza, Hofstra, van der Ende, & Verhulst, 2003). Research has implicated many factors in the etiology of child internalizing/externalizing problems, including unalterable factors such as race (e.g., Hatcher,

Maschi, Morgen, & Toldson, 2009) and gender (e.g., Fanti & Henrich, 2010). Researchers have also identified several modifiable (i.e., alterable) factors that may contribute to the emergence of emotional and behavioral problems, including child maltreatment (e.g., Godinet, Li, & Berg, 2014), domestic violence (e.g., Moylan et al., 2010), parental incarceration (e.g., Wildeman, 2010), parental mental health problems (e.g., Turney, 2012) as well as parental substance use (e.g., Bountress & Chassin, 2015).

In addition to study the independent effects of particular ACEs, researchers have assessed the cumulative effect of multiple ACEs on child internalizing/externalizing problems. For example, using the Fragile Family and Child Wellbeing Study (FFCWS) data, Jimenez and colleagues (2016) found that greater exposure to ACEs by age 5 was associated with poorer academic performance, emergent literacy skills, and social-emotional functioning (e.g., attention problems, social problems, and aggression). Another recent investigation of the FFCWS dataset showed that enduring a greater number of ACEs from child's birth through age 5 was significantly associated with externalizing and internalizing behaviors (Hunt, Slack, & Berger, 2017). Another recent exploration of the FFCWS dataset by Wang and Maguire-Jack (2018) found that children's ACEs at age 3 mediated the relation between neighborhood disorder and child internalizing and externalizing problems at age 5.

Although scholars have tested the cumulative effect of ACEs on child internalizing/externalizing problems, these studies have focused on child outcomes at one time point. Less is known about the cumulative effect of ACEs on the trajectories of children's internalizing/externalizing development. Studies along these lines can be guided by similar research on the impact of child maltreatment. For instance, in a study of 484 children from the Longitudinal Studies of Child Abuse and Neglect (LONGSCAN), investigators examined the effect of maltreatment from birth to age 4 on the trajectories of both internalizing and externalizing problems at age 4, 6, 8, 10, and 12. They found that, for

boys, the impact of early maltreatment was strongest on the most proximal assessment of internalizing/externalizing outcomes and then decreased gradually over time. For girls, there was no significant impact observed at each time point, though the impact of early maltreatment increased over time (Godinet, Li, & Berg, 2014). Another study of the LONGSCAN dataset by Li and Godinet (2014) revealed that maltreatment was not associated with significant differences in behavior problems at discrete time points in early childhood (e.g., age 4 and age 6), but repeated maltreatment did increase the risk of internalizing and externalizing problems over time. Additionally, in another analysis of FFCWS data, Font and Berger (2015) reported that the effects of year 3 child maltreatment emerged soon on year 5 internalizing/externalizing problems, but the effect of year 5 maltreatment on year 9 internalizing/externalizing problems was not significant in general.

Impact of Child Internalizing/Externalizing Problems on Childhood Adversity

Although many child factors, parental, and environmental factors have been implicated in the etiology of child maltreatment (MacKenzie, Kotch, & Lee, 2011; Stith et al., 2009), few studies have explored whether children with internalizing/externalizing problems are at an elevated risk of experiencing maltreatment or other ACEs. One prospective study of 644 families in upstate New York did show that certain child characteristics, such as difficult temperament, anxiety or withdrawal are related with greater risk of child maltreatment (Brown, Cohen, Johnson, & Salzinger, 1998). Another study of 1,015 children and parents revealed that child internalizing/externalizing problems were related to perceived parent burden and psychological problems (Angold, Messer, Stangl & Burns, 1998), which are associated with potential child maltreatment (Stith et al., 2009). A more recent, longitudinal study by Font and Berger (2015) also found that year 3 child internalizing/externalizing problems significantly predicted year 5 maltreatment, and year 5 internalizing/externalizing problems also significantly predicted year 9 maltreatment. Yet, if child internalizing and

externalizing problems also increase ACEs, the cumulative risk is still unknown.

The Current Study

This study uses longitudinal data from the FFWCS to examine bidirectional relations between ACEs and child internalizing/externalizing problems at four different points from ages 3 to 15. The main research aim is to test whether exposure to ACEs significantly alters children's trajectories of internalizing/externalizing problems, and also to determine if internalizing/externalizing problems also increase the risk of ACEs over time. Such findings may also be used to optimize the timing of prevention and intervention programs and to target those strategies to populations that may benefit the most. Two main research questions are addressed in the current study:

1. Does earlier exposure to ACEs increase the risk of later child internalizing/externalizing problems in early childhood, middle childhood, and adolescence?
2. Do earlier child internalizing/externalizing problems also have impacts on the trajectories of children's ACEs exposure from early childhood through middle adolescence?

Methods

Data and Sample

This study is a secondary data analysis of the FFCWS dataset. The FFCWS is a birth cohort study of 4,898 children born into low-income families between 1998 and 2000. The study used a stratified random sample of 20 U.S. cities with more than 200,000 people, and then sampled hospitals within cities and births within hospitals. FFCWS families were interviewed soon after their child's birth and again when the child was about 1, 3, 5, 9 and 15 years old. For the current study, information on the focal child's ACEs and internalizing/externalizing problems was obtained from the primary caregiver's telephone and in-home interviews at four time points: year 3, year 5, year 9 and year 15. Usually, the primary caregiver is the child's mother. The current study sample included 4,231 primary

caregivers who ever accepted the telephone and in-home interviews at any of the four time points.

Measures

In this study, eight types of ACEs were measured: physical abuse, emotional abuse, sexual abuse, neglect, parental domestic violence, parental mental illness, parental substance use, and parental incarceration. Unlike the seminal Adverse Childhood Experiences Study (Felitti et al., 1998), parental divorce or separation was not included in this study, because FFCWS oversampled non-marital families (Reichman, Teitler, Garfinkel, & McLanahan, 2001). Also, divorce/separation is only an ACE when compared to being raised in a stable household with married parents (Wade, Shea, Rubin, & Wood, 2014). But in low-income samples such as the FFCWS, rates of marriage are low (FFCWS, 2014). Thus, the effects of divorce/separation are attenuated because children with divorced/separated parents are being compared to a mixed group of children-some whose parents are still married but many whose parents never married in the first place. Moreover, the original ACE Study was able to differentiate emotional neglect and physical neglect, while the FFCWS only permits the measurement of global child neglect. It should also be noted that data on sexual abuse were not gathered at year 3 (see Appendix A for all ACEs measures and scoring methods at each time point).

Child Maltreatment.

Primary child maltreatment data for this study were drawn from caregiver responses to the Conflict Tactics Scale: Parent Child Version (CTS-PC; Straus, Hamby, Finkelhor, Moore, & Runyan, 1998). CTS-PC has demonstrated adequate test-retest reliabilities, internal consistency and construct validity (Straus et al., 1998). In year 3, 5 and 9 surveys, caregiver parenting behaviors were measured by 3 subscales of CTS-PC: physical assault, psychological aggression and neglect. There are 5 items about physical assault (e.g., shook

child; hit child on bottom with hard object), 5 items about psychological aggression (e.g., shouted, yelled, or screamed at child; called child dumb or lazy), and 5 items about neglect (e.g., left child home alone; not able to make sure child got the food he/she needed; were not able to show love to child). Replicating similar studies of the FFCWS dataset (e.g., Hunt, Slack, & Berger, 2017; Jimenez, Wade, Lin, Morrow, & Reichman, 2016), a midpoint score was assigned for each physical assault item (i.e., never or not in the past year = 0; once = 1; twice = 2, 3-5 times = 4, 6-10 times = 8, 11-20 times = 15, more than 20 times = 25), and all item scores were summed to create a total domain score. Total scores were then dichotomized, with the top 10th percentile of physical assault frequency denoting physical abuse. The same methodology was used to create the emotional abuse variable from the psychological aggression subscale and the neglect variable from the neglect subscale. The year 15 survey included only one physical assault question (hit or slapped youth in past year) and one psychological aggression question (shouted, yelled, screamed or swore at youth in past year). A reply of “often” (vs. “never” and “sometimes”) was used to classify participants as physical abused and emotional abused, respectively.

A second complementary source of child maltreatment came from primary caregiver self-report at year 5, 9 and 15. Caregivers were asked if child protective services had concern about the family’s physical abuse, sexual abuse and neglect. An affirmative response to a concern was also used to classify participants as having experienced a given form of maltreatment.

Parental Domestic Violence.

For year 3, 5 and 9 interviews, parental responses to the Conflict Tactics Scale (CTS; Straus, Hamby, Boney-McCoy, & Sugarman, 1996) was the primary source of domestic violence data. CTS has been psychometrically validated (Straus et al., 1996). Mothers were asked if their child’s father or their current partner engaged in violent behaviors toward her

(e.g., slaps or kicks you (mother), tries to make you have sex or do sexual things you don't want to do). A response of "sometimes" or "often" to any item indicated domestic violence exposure while a response of "never" indicated no exposure. The CTS was not included in the year 15 interview, however. Secondary domestic violence data at year 15 and other time points were available from single-item survey measures, including: "Have you been seriously hurt in fight with father/current partner"; "(Primary caregiver) had physical fight with spouse/partner in front of youth in past year/since last interview". An affirmative response to any of these questions indicated parental domestic violence.

Parental Mental Illness.

Parental mental illness was measured by the Composite Interview Diagnostic Interview-Short Form (CIDI-SF; Kessler, Andrews, Mroczek, Ustun, & Wittchen, 1998). Respondents were asked if they have had feelings of depression or inability to enjoy what is usually pleasurable in the past year that lasted for two weeks or more, and if so, whether the symptoms lasted most of the day and occurred every day of the two-week period. If so, they were asked more specific questions about: 1) losing interest, 2) feeling tired, 3) change in weight, 4) trouble sleeping, 5) trouble concentrating, 6) feeling worthless, and 7) thinking about death. There are two ways to meet the diagnostic stem requirement for major depression: 1) to endorse all questions about having two weeks of dysphoric mood; or 2) to endorse all questions about having two weeks of anhedonia. CIDI-SF has demonstrated decent psychometric validity (Kessler et al., 1998). If a mother met the CIDI depression liberal criteria (see Walters, Kessler, Nelson, & Mroczek, 2002), it indicated child's exposure to parental mental illness.

Parental Substance Use.

Parental substance use was measured by mothers' responses to questions about personal use or use by the child's father or her current partner. Sample items included: "Did you (mother) use any of these drugs in the past year?" and "Does father/current partner have

problems keeping job or getting along with family and friends because of alcohol or drug use?” Any affirmative response to these questions indicated exposure. In addition, mothers were asked another four items about personal alcohol use (e.g., if drinking alcohol interfered with responsibilities in past year; if she had problems with people because of alcohol in past year). A response of “more than one time” to any of the four questions indicated parental substance use.

Parental Incarceration.

Parental incarceration indicates if the focal child’s mother, father and/or current partner was in jail or had spent some time in jail. Sample items included “Is father currently in jail?” and “Spouse/partner/primary caregiver spent some time in jail since last interview?”. An affirmative response to any of these questions was defined as exposure to parental incarceration.

Adverse Childhood Experiences Score.

All ACEs were dichotomized at each measurement time point according to whether the focal child has exposed to it or not, then all eight ACEs dichotomies were summed to produce an aggregate ACE score at each time point.

Child Internalizing/Externalizing Problems.

The Child Behavioral Checklist (CBCL; Achenbach, 1991) was used to measure children’s internalizing/externalizing problems reported by primary caregiver’s year 3, 5, 9 and 15 interviews. CBCL has demonstrated great psychometrical validity (Achenbach, 1991). Four CBCL problem subscales were measured: (1) anxious/depressed (sample item = child cries a lot), (2) withdrawn (sample item = child would rather be alone than with others), aggressive (sample item = child gets in many fights), and destructive/delinquent (child steals at home). Subscale items vary in content and numbers by age at each time point (all items are reported in Appendix B). Each CBCL item is measured on a 3-point scale: *not true for this*

child (0), sometimes or somewhat true (1), and very true or often true (2). For each subscale, the items were summed to create a total score at each time point. Then the subscale score was standardized to have a mean of zero and a standard deviation of one.

Covariates.

The following covariates were measured at or near the time of the child's birth: child gender and maternal age, race/ethnicity (non-Hispanic White, non-Hispanic Black, Hispanic, other), household annual income, and education level (range = less than high school to college graduate).

Analysis Strategy

Descriptive statistics were computed using SPSS version 23 for sample demographics and the prevalence of ACEs. Bivariate correlation analysis was also performed by SPSS for ACEs and internalizing/externalizing problems at different time points. A random intercept cross-lagged panel model (RI-CLPM) (Hamaker, Kuiper, & Grasman, 2015) was used to assess bidirectional relations between the number of ACEs and children's internalizing/externalizing problems across time. Unlike a traditional Cross Lagged Panel Model (CLPM), the RI-CLPM can adequately account for the trait-like, time-invariant nature stability of constructs. "Even if the constructs are not characterized by time-invariant, trait-like differences, running the RI-CLPM will not affect the results substantially" (Hamaker et al., 2015). The RI-CLPM analysis was performed with Mplus 8 using Information Maximum Likelihood (FIML) to handle missing data. Figure 1 shows the conceptual RI-CLPM (Hamaker, 2018) adopted in this study.

(Figure 1 Inserted Here)

Results

Table 1 presents the baseline demographic characteristics of the study sample. Results showed that 52.2% of children were male. The mean age of participant mothers was 25.1 (*SD*

= 6.0); 21.2% were White, 48.5% were Black, 26.8% were Hispanic, and 3.5% were other race/ethnicity. Less than two-thirds (65.3%) of mothers had high school or less education. The average annual household income of these women were 31759.9 (*SD* = 31334.8). Table 2 shows the prevalence of ACEs at four independent time points. Results showed that 52.4%, 55.0% and 53.6% of children had at least 1 reported ACE in study years 3, 5, and 9, respectively. For year 15, the number decreased slightly to 46.9%. From year 3 to year 15, 86.8% of children were exposed to at least 1 ACE, and 23.8% of children were exposed to 4 or more ACEs. The most prevalent ACEs were household mental illness (44.1%), substance use (37.0%), and incarceration (33.1%).

(Table 1 Inserted Here)

(Table 2 Inserted Here)

Table 3 presents bivariate correlations among ACEs at each time point. It also shows related mean, standard deviation, and range of ACEs. Correlations between ACEs measured at year 3, year 5, year 9, and year 15 were significant, with year-to-year correlations ranging from .317 (years 3 and 15) to .496 (years 3 and 5). The mean number of ACEs reported was .905 (*SD* = 1.102; range 0-6) at year 3, 1.028 (*SD* = 1.243; range = 0-7) at year 5, .933 (*SD* = 1.115; range = 0-6) at year 9, and .767 (*SD* = 1.007; range = 0-5) at year 15.

Table 4 shows the correlations among internalizing/externalizing problems at four time points. For each problem subscale, the correlations were significant at all time points. For anxious/depressed problem, the year to year correlations range from .151(year 3 and 15) to .364 (year 3 and 5). For withdrawn problem, the year to year correlations range from .132 (year 3 and 15) to .371(year 3 and 5). For aggression problem, the year to year correlations range from .288 (year 3 and 15) to .545 (year 3 and 5). For delinquent problem, the year to year correlations range from .203 (year 3 and 5) to .350 (year 3 and 15).

(Table 3 Inserted Here)

(Table 4 Inserted Here)

The RI-CLPM fit the data well according to four indicators of goodness of fit (see Appendix C): Comparative Fit Index (CFI), Tucker Lewis Index (TLI), Root Mean Square Error of Approximation (RMSEA), and Standardized Root Mean Square Residual (SRMR). The chi-square (χ^2) values were significant, which is common in large samples (Jöreskog & Sörbom, 1993).

Table 5 presents the results of RI-CLPM analysis. It shows that year 5 ACE scores significantly predicted year 9 anxious/depressed problems ($\beta=0.116$, $SE=0.030$, $p < 0.001$) and year 9 aggressive problem ($\beta=0.080$, $SE=0.036$, $p < 0.05$). Also, year 5 anxious/depressed problems significantly predicted later year 9 ACEs exposure ($\beta=0.094$, $SE=0.024$, $p < 0.001$). The coefficients for each case from year 3 to year 9 showed that the effect of earlier ACEs on later internalizing/externalizing problems was larger than the effect of earlier internalizing/externalizing problems on later ACEs, although the effect was not always statistically significant. However, this pattern was opposite between year 9 and year 15, and the potential reasons accounting for this would be discussed below.

(Table 5 Inserted Here)

Discussion

This study makes a novel contribution to the literature by examining the longitudinal and reciprocal relationship between ACEs and the emergence of internalizing/externalizing problems from early childhood to adolescence. Results indicated that roughly half of children were exposed to an ACE at each of the study's four measurement time points. In aggregate, approximately 87% endured one or more ACEs during the study period. This prevalence figure is much higher than published estimates in the general U.S. population (Green et al., 2010; Merrick, Ford, Ports, & Guinn, 2018), and it is more comparable to rates that have been reported in other low-income samples in the U.S. (Chung et al., 2010; Mersky,

Janczewski, & Topitzes, 2017; Topitzes, Pate, Berman, & Medina-Kirchner, 2016). ACE scores at years 3, 5, 9, and 15 of the study were significantly correlated, with correlations ranging from ($r = .317 - .496$), which indicated that there was variation of ACEs exposure over time.

Similarly, maternal ratings of children on the CBCL problem subscales were significantly correlated at each time point, signifying continuity in children's internalizing and externalizing problems. The results reinforce a large body of literature that has documented continuity in children's developmental trajectories (Bongers, Koot, van der Ende, & Verhulst., 2003; Colder, Mott, & Berman, 2002, Keiley, Lofthouse, Bates, Dodge, & Pettit, 2003; Owens & Shaw, 2003; Sterba, Prinstein, & Cox, 2007).

Results from a cross-lagged panel model indicated that year 5 ACEs scores were significantly related to year 9 anxious/depressed problems and year 9 aggressive problem. Also, year 5 anxious/depressed problems significantly predicted later year 9 ACEs exposure. It seems that significant bidirectional relationship was only found between year 5 and year 9. A possible explanation for this is that internalizing/externalizing problems have not yet showed up at such young age. In the study of Li and Godinet (2014), they found that repeated maltreatment was related with increases in internalizing/externalizing problems over time, but there were no differences in early internalizing/externalizing problems assessment at age 4 and age 6. Since age 8, internalizing/externalizing problems emerged and became more pronounced among those with repeated maltreatment. However, using the FFCWS data to assess the bidirectional relationship between child maltreatment and internalizing/externalizing problems from year 3 to year 9, Font and Berger (2015) had opposite findings. They reported that the effects of year 3 child maltreatment emerged soon on year 5 internalizing/externalizing problems, and year 3 internalizing/externalizing problems also significantly predicted year 5 child maltreatment. But year 5 maltreatment

didn't significantly predict year 9 internalizing/externalizing problems in general, although year 5 internalizing/externalizing problems was found to significantly predict year 9 child maltreatment in their study. Of course, Font and Berger's study used child maltreatment rather than ACEs to estimate the reciprocal relationship with internalizing/externalizing problems. This might make the findings different. But another potential reason is they used the traditional cross-lagged panel model rather than the random intercept cross-lagged panel model. In the article "A Critique of the Cross-Lagged Panel Model", Hamaker et al. (2015) had pointed out the weaknesses of traditional cross-lagged panel model, including the neglect of stable, trait-like individual differences. They also warned that the traditional cross-lagged panel model might get totally erroneous and different results from the random intercept cross-lagged model using the same data. Additionally, other ACEs studies using FFCWS data also found that year 5 ACEs significantly predicted internalizing/externalizing problems at year 9 (Hunt, Slack, & Berger, 2017; Jimenez, Wade, Schwartz-Soicher, Lin, & Reichman, 2017). These findings might further confirm that ACEs significantly predicted child internalizing and externalizing problems at later childhood among fragile family children.

In the current study, it was also found that there was no significant bidirectional relationship for year 9 and year 15. Also, results suggest that from year 3 to year 9, the coefficients of ACEs predicting internalizing/externalizing problems were always bigger than the coefficients of internalizing/externalizing problems predicting ACEs. This indicated that ACEs played a causally domain role in the reciprocal relationship with internalizing/externalizing problems. However, this result was not found for year 9 and year 15 either. Potential reasons accounting for this may be the following: First, the measurement of child maltreatment and internalizing/externalizing problems at year 15 was not as comprehensive as at other time points. As described in methods part, many items of CTS-PC and CBCL were not included at year 15 measurement. This might lead to spurious

measurement of ACEs and internalizing/externalizing problems, which biased the bidirectional relationship between ACEs and internalizing/externalizing problems for year 9 and year 15. Second, the time gap between year 9 and year 15 is big. According to the Life Course Perspective, there is greater impact from adverse experiences which is more proximal to the outcome of interest (Appleyard, Egeland, van Dulman, & Sroufe., 2005; Elder, 1998; Ireland, Smith, & Thornberry., 2002; Thornberry, Ireland, & Smith, 2001). Therefore, the big time gap may be another potential factor that biased the bidirectional results between year 9 and year 15.

Finally, this study only found significant results for anxious/depressed problem and aggressive problem, but not for withdrawn and delinquent problems. This finding is also supported by prior research. First of all, many studies have confirmed the comorbidity of anxious/depressive problem and aggressive problem in children (e.g., Garber, Quiggle, Panak, & Dodge, 1991; Weiss & Catron, 1994). Also, research has found that comparing to other internalizing and externalizing problems, anxious/depressive problem and aggressive problem are more likely to be caused by child maltreatment (Ethier, Lemelin, & Lacharite, 2004).

Limitations

This study is unique in its longitudinal design in examining the reciprocal effect of ACEs and internalizing/externalizing problems occurring at four different time points from early childhood through middle adolescence. However, some limitations should also be considered when interpreting the study results. First, the study sample consisted of children from relatively disadvantaged families in large U.S. cities. Thus, the study results may not be generalizable to the general population or samples of children who were raised in more advantaged contexts. Second, this study mainly relied on maternal self-report interview data, which have well-known limitations. For instance, children's ACEs and

internalizing/externalizing problems may have been underreported due to social desirability. Third, although the CTS-PC and CBCL are well validated measures, they were not implemented consistently at each time point. This may have led to mismeasurement of child maltreatment and internalizing/externalizing problems. Fourth, the ACEs included in this study might not fully reflect the adversities that disadvantaged urban children experienced. Some researchers have also suggested that other adversities such as community violence, peer victimization, family financial problems also greatly impact individuals' health outcomes (Finkelhor et al, 2015; Mersky et al., 2017; Wade, Shea, Rubin, & Wood, 2014).

Implications and Future Directions

Despite the above caveats, this research has highlighted the importance of understanding children's ACEs and internalizing/externalizing problems longitudinally and bidirectionally. The study findings also have significant implications for practice and future ACE research. First of all, study results reinforce the importance of early detection and intervention for ACEs and internalizing/externalizing problems since early childhood. Although internalizing and externalizing problems may not be seen in younger children who experience multiple adversities, it is prudent to be aware that the impact may likely emerge in later ages of the child. Thus, ongoing monitoring and assessment of treatment needs for children is necessary to break the trajectories of ACEs and internalizing/externalizing problems. Second, since most ACEs occur in the home environment, especially at earlier ages, there is a need for high-quality, evidence-based family support programs and policies that promote positive parenting and household stability.

There also is a great need for approaches that prevent ACEs and child emotional and behavioral difficulties. For example, there is some evidence to suggest that two-generation programs such as home visiting have the potential to enhance maternal sensitivity, household functioning, and child development. Home visiting practitioners may especially pay attention

to the anxious/depressive problem and aggressive problem in children since age 5, since the two problems often co-occur and they also significantly interact with ACEs during middle childhood. Home visiting practitioners may also work collaboratively with schools to identify and support children who are experiencing childhood adversities and internalizing/externalizing problems and other health problems.

Future research should use more consistent measurement for ACEs and internalizing/externalizing problems in longitudinal study. Researchers may also consider a wider range of childhood adversities, and include data from other collateral sources like fathers, grandparents and school teachers. Future studies should also explore whether associations between ACEs and the trajectories of internalizing/externalizing problems vary by gender, as prior studies have found that trajectories for internalizing/externalizing problems often differ for boys and girls (e.g., Bongers, Koot, van der Ende, & Verhulst, 2003; Broidy et al., 2003). Finally, the current study didn't consider any protective factors that might buffer the effect of ACEs on the trajectories of internalizing/externalizing problems. Future ACE research may include protective factors like social support from adults or peers to determine if they promote resilience in the face of adversity.

References

- Achenbach, T. M. (1991). *Manual for the Child Behavior Checklist/4-18 and 1991 profile*. Burlington: Department of Psychiatry, University of Vermont.
- Anda, R. F., Brown, D. W., Dube, S. R., Bremner, J. D., Felitti, V. J., & Giles, W. H. (2008). Adverse childhood experiences and chronic obstructive pulmonary disease in adult. *American Journal of Preventive Medicine, 34*, 396-403.
- Anda, R. F., Butchart, A., Felitti, V. J., & Brown, D. W. (2010). Building a framework for global surveillance of the public health implications of adverse childhood experiences. *American Journal of Preventive Medicine, 39*(1), 93-98.
- Anda, R. F., Chapman, D. P., Felitti, V. J., Edwards, V., Williamson, D. F., Croft, J. B., & Giles, W. H. (2002). Adverse childhood experiences and risk of paternity in teen pregnancy. *Obstetrics and Gynecology, 100*(1), 37-45.
- Anda, R. F., Croft, J. B., Felitti, V. J., Nordenberg, D., Giles, W. H., Williamson, D. F., & Giovino, G. A. (1999). Adverse childhood experiences and smoking during adolescence and adulthood. *JAMA, 282*, 1652-1658.
- Anda, R. F., Felitti, V. J., Bremner, J. D., Walker, J. D., Whitfield, C., Perry, B. D., Dube, S. R., & Giles, W. H. (2006). The enduring effects of abuse and related adverse experiences in childhood. *European Archives of Psychiatry and Clinical Neuroscience, 256*, 174-186.
- Angold, A., Messer, S. C., Stangl, D., & Burns, E. J. (1998). Perceived parental burden and service use for child and adolescent disorders. *American Journal of Public Health, 88*, 75-80.
- Appleyard, K., Egeland, B., van Dulman, M. H., & Sroufe, L. A. (2005). When more is not better: The role of cumulative risk in child behavior outcomes. *Journal of Child Psychology and Psychiatry, 46*, 235-245.

- Baglivio, M. T., Epps, N., Sheer, A., & Hardt, N. S. (2014). The prevalence of adverse childhood experiences (ACE) in the lives of juvenile offenders. *OJJDP Journal of Juvenile Justice*, 3(2), 1-23.
- Bethell, C. D., Newacheck, P., Hawes, E., & Halfon, N. (2014). Adverse childhood experiences: assessing the impact on health and school engagement and the mitigating role of resilience. *Health Affairs*, 33(12), 2106-2115.
- Bongers, I. L., Koot, H. M., van der Ende, J., & Verhulst, F. C. (2003). The normative development of child and adolescent problem behavior. *Journal of Abnormal Psychology*, 112(2), 179-192.
- Bountress, K., & Chassin, L. (2015). Risk for behavior problems in children of parents with substance use disorders. *American Journal of Orthopsychiatry*, 85(3), 275-286.
- Briere, J., & Runtz, M. (1998). Symptomatology associated with childhood sexual victimization in a non-clinical sample. *Child Abuse & Neglect*, 12, 51-59.
- Bright, M. A., Alford, S. M., Hinojosa, M. S., Knapp, C., & Fernandez-Baca, D. E. (2015). Adverse childhood experiences and dental health in children and adolescents. *Community Dentistry and Oral Epidemiology*, 43(3), 193-199.
- Broidy, L. M., Nagin, D. S., Tremblay, R. E., Bates, J. E., Brame, B., Dodge, K. A., . . . Vitaro, F. (2003). Developmental trajectories of childhood disruptive behaviors and adolescent delinquency: A six-site, cross-national study. *Developmental Psychology*, 39(2), 222-245.
- Brown, J., Cohen, P., Johnson, J. G., & Salzinger, S. (1998). A longitudinal analysis of risk factors for child maltreatment: Findings of a 17-year prospective study of officially recorded and self-reported child abuse and neglect. *Child Abuse & Neglect*, 22, 1065-1078.

- Burke, N. J., Hellman, J. L., Scott, B. G., Weems, C. F., & Carrion, V. G. (2011). The impact of adverse childhood experiences on an urban pediatric population. *Child Abuse & Neglect*, 35, 408-413.
- Centers for Disease Control and Prevention, Kaiser Permanente. (2016). *The ACE Study Survey Data* [Unpublished data]. Atlanta, GA: U.S. Department of Health and Human Services, Center for Disease Control and Prevention. Retrieved from: <https://www.cdc.gov/violenceprevention/acestudy/about.html>
- Chapman, D. P., Whitfield, C. L., Felitti, V. J., Dube, S. R., Edwards, V. J., & Anda, R. F. (2004). Adverse childhood experiences and the risk of depressive disorders in adulthood. *Journal of Affective Disorders*, 82, 217-225.
- Chung, E. K., Nurmohamed, L., Mathew, L., Elo, I. T., Coyne, J. C., & Culhane, J. F. (2010). Risky health behaviors among mothers-to-be: The impact of adverse childhood experiences. *Academic Pediatrics*, 10(4), 245-251.
- Coie, J. D., & Dodge, K. A. (1998). Aggression and antisocial behavior. In W. Damon & N. Eisenberg (Eds.), *Handbook of child psychology: Vol. 3. Social, emotional, and personality development* (PP. 779-862). New York, NY: Wiley.
- Colder, C. R., Mott, J. A., & Berman, A. S. (2002). The interactive effects of infant activity level and fear on growth trajectories of early childhood behavior problems. *Developmental & Psychopathology*, 14, 1-23.
- Dong, M., Dube, S. R., Felitti, V. J., Giles, W. H., & Anda, R. F. (2003). Adverse childhood experiences and self-reported liver disease: New insights into the causal pathway. *Archives of Internal Medicine*, 163, 1949-1956.
- Dong, M., Giles, W. H., Felitti, V. J., Dube, S. R., Williams, J. E., Chapman, D. P., & Anda, R. F. (2004). Insights into causal pathways for ischemic heart disease: Adverse childhood experiences study. *Circulation*, 110, 1761-1766.

- Dube, S. R., Anda, R. F., Felitti, V. J., Chapman, D. P., Williamson, D. F., & Giles, W. H. (2001). Childhood abuse, household dysfunction, and the risk of attempted suicide throughout the life span: Findings from the Adverse Childhood Experiences Study. *Pediatrics, 111*, 564-572.
- Dube, S. R., Anda, R. F., Felitti, V. J., Edwards, V. J., & Croft, J. B. (2002). Adverse childhood experiences and personal alcohol abuse as an adult. *Addictive Behaviors, 27*, 713-725.
- Dube, S. R., Fairweather, D., Pearson, W. S., Felitti, V. J., Anda, R. F., & Croft, J. B. (2009). Cumulative childhood stress and autoimmune diseases in adults. *Psychosomatic Medicine, 71*, 243-250.
- Dube, S. R., Felitti, V. J., Dong, M., Chapman, D. P., Giles, W. H., & Anda, R. F. (2003). Childhood abuse, neglect, and household dysfunction and the risk of illicit drug use: The adverse childhood experiences study. *Pediatrics, 111*, 564-572.
- Dube, S. R., Miller, J. W., Brown, D. W., Giles, W. H., Felitti, V. J., Dong, M., & Anda, R. F. (2006). Adverse childhood experiences and the association with ever using alcohol and initiating alcohol use during adolescence. *Journal of Adolescent Health, 38*, 444.e1-444.e10.
- Duke, N. N., Pettingell, S. L., McMorris, B. J., & Borowsky, I. W. (2010). Adolescent violence perpetration: Associations with multiple types of adverse childhood experiences. *Pediatrics, 125*, 778-786.
- Duncan, G., Claussens, A., & Engel, M. (2004). The contribution of hard skills and socio-emotional behavior to school readiness. Mimeo. Northwestern University.
- Elder, G. H. (1998). The life course as developmental theory. *Child Development, 69*, 1-12.

- Ethier, L. S., Lemelin, J. P., & Lacharite, C. (2004). A longitudinal study of the effects of chronic maltreatment on children's behavioral and emotional problems. *Child Abuse & Neglect, 28*, 1265-1278.
- Fanti, K. A., & Henrich, C. C. (2010). Trajectories of pure and co-occurring internalizing and externalizing problems from age 2 to age 12: findings from the National Institute of Child Health and Human Development Study of Early Child Care. *Developmental Psychology, 46*(5), 1159-1175.
- Feinstein, L., & Sabates, R. (2006). *Predicting adult life outcomes from earlier signals: Identifying those at risk*. London: Institute of Education, University of London.
- Felitti, V. J. (2002). The relationship of adverse childhood experiences to adult health: Turning gold into lead. *Zeitschrift Fur Psychosomatische Medizin und Psychotherapie, 48*(4), 359-369
- Felitti, V. J., Anda, R. F., Nordenberg, D., Williamson, D. F., Spitz, A. M., Edwards, V., Koss, M. P., & Marks, J. S. (1998). Relationship of childhood abuse and household dysfunction to many of the leading causes of death in adults: The Adverse Childhood Experiences (ACE) Study. *American Journal of Preventive Medicine, 14*(4), 245-258.
- FFCWS. (2014). Fragile Families and Child Wellbeing Study: A national, long-term study of the causes and consequences of childbearing outside marriage. Retrieved from https://fragilefamilies.princeton.edu/sites/fragilefamilies/files/rwjf_program_results_report.pdf
- Flaherty, E. G., Thompson, R., Dubowitz, H., Harvey, E. M., English, D., Everson, M. D., Proctor, L. J., & Runyan, D. K. (2013). Adverse childhood experiences and child health in early adolescence. *JAMA Pediatrics, 167*, 622-629.
- Flaherty, E. G., Thompson, R., Litrownik, A. J., Theodore, A., English, D. J., Black, M. M., Wike, T., & Whimper, L. (2006). Effect of early childhood adversity on child health.

- Archives of Pediatrics and Adolescent Medicine*, 160,1232-1238.
- Flaherty, E. G., Thompson, R., Litrownik, A. J., Zolotor, A. J., & Dubowitz, H. D. (2009). Adverse childhood exposures and reported child health at age 12. *Academic Pediatrics*, 9, 150-156.
- Font, S. A., & Berger, L. M. (2015). Child maltreatment and children's developmental trajectories in early to middle childhood. *Child Development*, 86(2), 536-556.
- Fox, B. H., Perez, N., Cass, E., Baglivio, M. T., & Epps, N. (2015). Trauma changes everything: Examining the relationship between adverse childhood experiences and serious, violent and chronic juvenile offenders. *Child Abuse & Neglect*, 46, 163-173.
- Freeman, P. (2014). Prevalence and relationship between adverse childhood experiences and child behavior among young children. *Infant Mental Health Journal*, 35(6), 544-554.
- Garber, J., Quiggle, N., Panak, W., & Dodge, K. (1991). Aggression and depression in children: Comorbidity, specificity, and social cognitive processing. In D. Cicchetti & S. L. Toth (Eds.), *Rochester Symposium on Developmental Psychopathology: Vol. 2. Internalizing and externalizing expressions of dysfunction* (pp. 225-264). Hillsdale, NJ: Erlbaum.
- Godinet, M. T., Li, F., & Berg, T. (2014). Early childhood maltreatment and trajectories of behavioral problems: Exploring gender and racial differences. *Child Abuse & Neglect*, 38, 544-556.
- Green, J. G., McLaughlin, K. A., Berglund, P. A., Gruber, M. J., Sampson, N. A., Zaslavsky, A. M., & Kessler, R. C. (2010). Childhood adversities and adult psychiatric disorders in the national comorbidity survey replication I: associations with first onset of DSM-IV disorders. *Archives of General Psychiatry*, 67(2), 113-123.
- Hatcher, S. S., Maschi, T., Morgen, K., & Toldson, I. A. (2009). Exploring the impact of racial and ethnic differences in the emotional and behavioral responses of maltreated

- youth: Implications for culturally competent services. *Children and Youth Services Review*, *31*, 1042-1048.
- Hamaker, E. L. (2018). How to run the RI-CLPM with Mplus. Retrieved from <https://www.statmodel.com/download/RI-CLPM%20Hamaker%20input.pdf>
- Hamaker, E. L., Kuiper, R. M., & Grasman, R. P. (2015). A critique of the cross-lagged panel model. *Psychological Methods*, *20*(1), 102-116.
- Henrichs, K. L., McCauley, H. L., Miller, E., Styne, D. M., Saito, N., & Breslau, J. (2014). Early menarche and childhood adversities in a nationally representative sample. *International Journal of Pediatric Endocrinology*, *2014*(1), 14.
- Hillis, S. D., Anda, R. F., Dube, S. R., Felitti, V. J., Marchbanks, P. A., & Marks, J. S. (2004). The association between adverse childhood experiences and adolescent pregnancy, long-term psychosocial consequences, and fetal death. *Pediatrics*, *113*, 320-327.
- Hillis, S. D., Anda, R. F., Felitti, V. J., & Marchbanks, P. A. (2001). Adverse childhood experiences and sexual risk behaviors in women: A retrospective cohort study. *Family Planning Perspectives*, *33*(5), 206-211.
- Hotaling, G. T., Straus, M. A., & Lincoln, A. J. (1989). Intrafamily violence, and crime and violence outside the family. In Lohlin & Mtonry (Eds.), *Family Violence* (pp. 315-375). Chicago: University of Chicago Press.
- Hunt, T. K. A., Slack, K. S., & Berger, L. M. (2017). Adverse childhood experiences and behavioral problems in middle childhood. *Child Abuse & Neglect*, *67*, 391-402.
- Ireland, T. O., Smith, C. A., & Thornberry, T. P. (2002). Developmental issues in the impact of child maltreatment on later delinquency and drug use. *Criminology*, *40*, 359-399.

- Isohookana, R., Riala, K., Hakko, H., & Räsänen, P. (2013). Adverse childhood experiences and suicidal behavior of adolescent psychiatric inpatients. *European Child & Adolescent Psychiatry*, 22(1), 13–22.
- Jacobs, J., Agho, K., Stevens, G., & Raphael, B. (2012). Do childhood adversities cluster in predictable ways? A systematic review. *Vulnerable Children & Youth Studies*, 7(2), 103-115.
- Jimenez, M. E., Wade, R. Jr., Lin, Y., Morrow, L. M., & Reichman, N. E. (2016). Adverse experiences in early childhood and kindergarten outcomes. *Pediatrics*, 137(2): e20151839.
- Jimenez, M. E., Wade, R. Jr., Schwartz-Soicher, O., Lin, Y., & Reichman, N. E. (2017). Adverse childhood experiences and ADHD diagnosis at age 9 years in a national urban sample. *Academic Pediatrics*, 17, 356-361.
- Jöreskog, K., & Sörbom, D. (1993). LISREL 8: Structural Equation Modeling with the SIMPLIS Command Language. Chicago, IL: Scientific Software International Inc.
- Keiley, M. K., Lofthouse, N., Bates, J. E., Dodge, K. A., & Pettit, G. S. (2003). Differential risks of covarying and pure components in mother and teacher reports of externalizing and internalizing behavior across ages 5 to 14. *Journal of Abnormal Child Psychology*, 31, 267-283.
- Kessler, R. C., Andrews, G., Mroczek, D., Ustun, T. B., & Wittchen, H. U. (1998). The world health organization composite international diagnostic interview short-form (CIDI-SF). *International Journal of Methods in Psychiatric Research*, 7, 171-185.
- Kovacs, M., & Devline, B. (1998). Internalizing disorders in childhood. *Journal of Child Psychology and Psychiatry*, 1, 47-63.

- Lê-Scherban, F., Wang, X., Boyle-Steed, K. H., Lee, M., & Pachter, D. O. (2018). Intergenerational Associations of Parent Adverse Childhood Experiences and Child Health Outcomes. *Pediatrics*, *141*(6): e20174274
- Li, F., & Godinet, M. T. (2014). The impact of repeated maltreatment on behavioral trajectories from early childhood to early adolescence. *Children and Youth Services Review*, *36*, 22-29.
- MacKenzie, M. J., Kotch, J. B., & Lee, L. (2011). Toward a cumulative ecological risk model for the etiology of child maltreatment. *Children and Youth Services Review*, *33*(9), 1638-1647.
- Malinosky-Rummell, R., & Hansen, D. J. (1993). Long term consequences of childhood physical abuse. *Psychological Bulletin*, *114*, 68-79.
- McLaughlin, K. A., Green, G. J., Gruber, M. J., Sampson, N. A., Zaslavsky, A. M., & Kessler, R. C. (2012). Childhood adversities and first onset of psychiatric disorders in a national sample of US adolescents. *Archives of General Psychiatry*, *69*(11), 1151–1160.
- Mersky, J. P., Janczewski, C. E., & Topitzes, J. (2017). Rethinking the measurement of adversity: Moving toward second-generation research on adverse childhood experiences. *Child Maltreatment*, *22*(1), 58-68.
- Merrick, M.T., Ford, D.C., Ports, K. A., & Guinn, A. S. (2018). Prevalence of Adverse Childhood Experiences From the 2011-2014 Behavioral Risk Factor Surveillance System in 23 States. *JAMA Pediatrics*, *172*(11), 1038-1044.
- Miller, E., Breslau, J., Chung, W. J. J., Green, J. G., McLaughlin, K. A., & Kessler, R. C. (2011). Adverse childhood experiences and risk of physical violence in adolescent dating relationships. *Journal of Epidemiology & Community Health*, *65*(11), 1006–1013.

- Moylan, C. A., Herrenkohl, T. I., Sousa, C., Tajima, E. A., Herrenkohl, R. C., & Russo, M. J. (2010). The effects of child abuse and exposure to domestic violence on adolescent internalizing and externalizing behavior problems. *Journal of Family Violence, 25*(1), 53-63.
- Mullen, P. E., Martin, J. L., Anderson, J. C., Romans, S. E., & Herbison, G. P. (1993). Childhood sexual abuse and mental health in adult life. *The British Journal of Psychiatry, 163*(6), 721-732.
- Nurius, P. S., Green, S., Logan-Greene, P., & Borja, S. (2015). Life course pathways of adverse childhood experiences toward adult psychological well-being: A stress process analysis. *Child Abuse & Neglect, 45*, 143-153.
- Owens, E. B., & Shaw, D. S. (2003). Predicting growth curves of externalizing behavior across the preschool years. *Journal of Abnormal Child Psychology, 31*, 575-590.
- Pretty, C., O'Leary, D., Cairney, J., & Wade, T. J. (2013). Adverse childhood experiences and the cardiovascular health of children: A cross-sectional study. *Journal of Abnormal Child Psychology, 36*(7), 1047-1056.
- Prino, C. T., & Peyrot, M. (1994). The effect of child physical abuse and neglect on aggressive withdrawn, and prosocial behavior. *Child Abuse & Neglect, 18* (10), 871-884.
- Reichman, N., Teitler, J., Garfinkel, I., & McLanahan, S. (2001). Fragile families: Sample and design. *Children and Youth Services Review, 23*(4-5), 303-326.
- Roza, S. J., Hofstra, M. B., van der Ende, J., & Verhulst, F. C. (2003). Stable prediction of mood and anxiety disorders based on behavioral and emotional problems in childhood: A 14-Year follow-up during childhood, adolescence, and young adulthood. *American Journal of Psychiatry, 160*(12), 2116-2121.

- Shipman, K. L., Schneider, R., Fitzgerald, M. M., Sims, C., Swisher, L., & Edwards, A. (2007). Maternal emotion socialization in maltreating and non-maltreating families: implications for children's emotion regulation. *Social Development, 16*(2), 268-285.
- Shonkoff, J. P., Garner, A. S., Siegel, B. S., Dobbins, M. I., Earls, M. F., McGuinn, L.,...& Wood, D. L. (2012). The lifelong effects of early childhood adversity and toxic stress. *Pediatrics, 129*(1), 232-246.
- Sterba, S. K., Prinstein, M. J., & Cox, M. J. (2007). Trajectories of internalizing problems across childhood: Heterogeneity, external validity, and gender differences. *Development and Psychopathology, 19*, 345-366.
- Sternberg, K. J., Lamb, M. E., Greenbaum, C., Cicchetti, D., Dawud, S., Cortes, R. M., Krispin, O., & Lorey, F. (1993). Effects of domestic violence on children's behavior problems and depression. *Developmental Psychology, 29*(1), 44-52.
- Stith, S. M., Liu, T., Davies, C., Boykin, E. L., Alder, M. C., Harris, J. M., Som, A., McPherson, M., & Dees, J. (2009). Risk factors in child maltreatment: A meta-analytic review of the literature. *Aggression and Violent Behavior, 14*(1), 13-29.
- Straus, M. A., Hamby, S. L., Boney-McCoy, S., & Sugarman, D. B. (1996). The revised Conflict Tactics Scales (CTS2): Development and preliminary psychometric data. *Journal of Family Issues, 17*(3), 283-316.
- Straus, M. A., Hamby, S. L., Finkelhor, D., Moore, D. W., & Runyan, D. (1998). Identification of child maltreatment with the Parent-Child Conflict Tactics Scales: Development and Psychometric Data for a national sample of American parents. *Child Abuse & Neglect, 22*(4), 249-270.
- Thompson, R., Flaherty, E. G., English, D. J., Litrownik, A. J., Dubowitz, H., Kotch, J. B., & Runyan, D. K. (2015). Trajectories of Adverse Childhood Experiences and Self-Reported Health at Age 18. *Academic Pediatrics, 15*(5), 503-509.

- Thompson, R., Litrownik, A. J., Isbell, P., Everson, M. D., English, D. J., Dubowitz, H., & Flaherty, E. G. (2012). Adverse experiences and suicidal ideation in adolescence: Exploring the link using the LONGSCAN samples. *Psychology of Violence, 2*(2), 211–225.
- Thornberry, T. P., Ireland, T. O., & Smith, C. A. (2001). The importance of timing: The varying impact of childhood and adolescent maltreatment on multiple problem outcomes. *Developmental Psychopathology, 13*, 957-979.
- Topitzes, J., Pate, D. J., Berman, N. D., & Medina-Kirchner, C. (2016). Adverse childhood experiences, health, and employment: A study of men seeking job services. *Child Abuse & Neglect, 61*, 23-34.
- Turney, K. (2012). Pathways of disadvantage: Explaining the relationship between maternal depression and children's problem behaviors. *Social Science Research, 41*, 1546-1564.
- Wade, R., Shea, J. A., Rubin, D., & Wood, J. (2014). Adverse childhood experiences of low-income urban youth. *Pediatrics, 134*(1), e13-e20.
- Walters, E. E., Kessler, R. C., Nelson, R. C., & Mroczek, D. (2002). Scoring the World Health Organization Composite International Diagnostic Interview Short Form (CIDI-SF).
- Wang, X., & Maguire-Jack, K. (2018). Family and environmental influences on child behavioral health: The role of neighborhood disorder and adverse childhood experiences. *Journal of Developmental & Behavioral Pediatrics, 39*(1), 28-36.
- Weiss, B., & Catron, T. (1994). Specificity of the comorbidity of aggression and depression in children. *Journal of Abnormal Child Psychology, 22*(3), 389-401.
- Wildeman, C. (2010). Paternal incarceration and children's physically aggressive behaviors: Evidence from the Fragile Families and Child Wellbeing Study. *Social Forces, 89*(1), 285-309.

Figure 1. Random Intercept Cross-Lagged Panel Model (RI-CLPM)

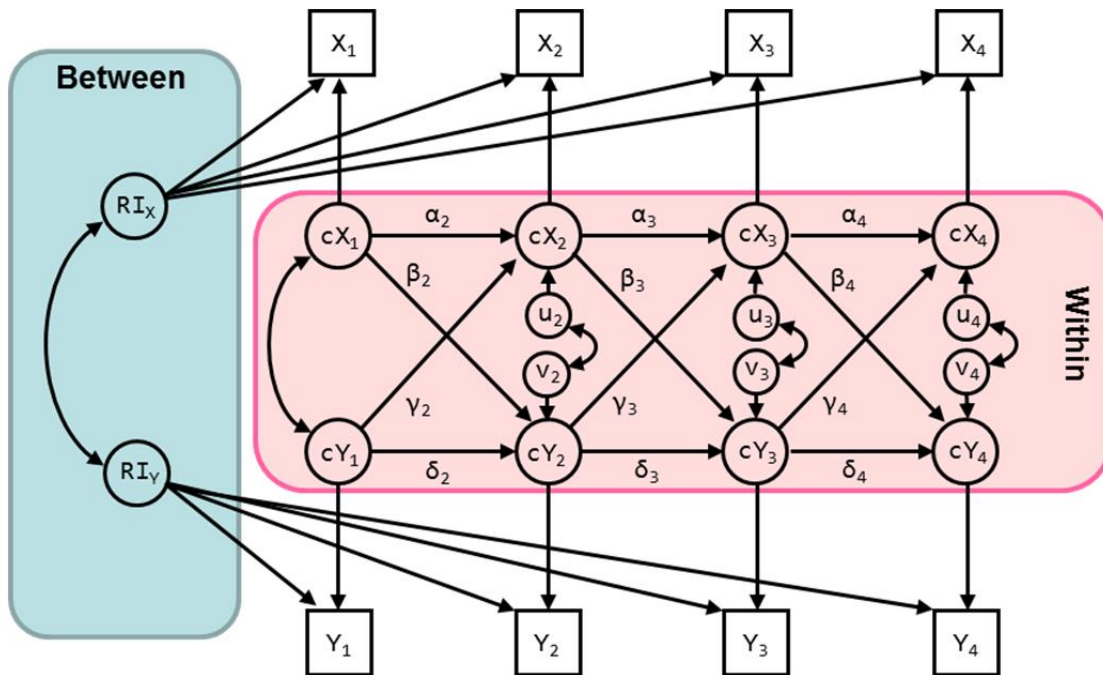

Note. X_1 = Year 3 ACEs, X_2 = Year 5 ACEs, X_3 = Year 9 ACEs, X_4 = Year 15 ACEs; Y_1 = Year 3 Internalizing/Externalizing Problems, Y_2 = Year 5 Internalizing/Externalizing Problems, Y_3 = Year 9 Internalizing/Externalizing Problems, Y_4 = Year 15 Internalizing/Externalizing Problems.

Table 1
Baseline Demographic Information

Variable	Study sample (n=4231) % (n) or Mean (SD)
Child gender	
Male	52.2% (2210)
Female	47.8% (2021)
Maternal age	M= 25.1 (SD= 6.0)
Maternal Race	
White	21.2% (898)
African American	48.5% (2051)
Hispanic	26.8% (1135)
Other	3.5% (147)
Maternal education	
Less than high school	39.5% (1673)
High school or equivalent	25.8% (1091)
Some college	24.1% (1021)
College or above	10.5% (446)
Maternal income	M= 31759.9 (SD= 31334.8)

Table 2
Prevalence of Adverse Childhood Experiences

Variables	Year 3 (n=3238) % (n)	Year 5 (n=2963) % (n)	Year 9 (n=3321) % (n)	Year 15 (n=3547) % (n)	Year 3-15 (n=3791) % (n)
Physical abuse	10.1 (328)	12.7 (376)	14.0 (466)	5.0 (179)	26.5 (1005)
Emotional abuse	11.1 (360)	10.5 (310)	11.2 (372)	14.2 (504)	29.6 (1121)
Neglect	11.1 (360)	15.7 (466)	13.8 (457)	2.2 (79)	28.4 (1077)
Sexual abuse	N/A	0.9 (28)	1.4 (46)	1.1 (39)	2.7 (104)
Domestic violence	11.3 (367)	12.8 (379)	7.9 (262)	3.4 (121)	27.6 (1048)
Substance abuse	15.3 (496)	14.7 (435)	20.6 (685)	15.0 (533)	37.0 (1402)
Mental illness	22.6 (731)	17.0 (505)	16.7 (556)	17.2 (610)	44.1 (1670)
Incarceration	8.9 (288)	18.5 (548)	7.6 (253)	18.5 (656)	33.1 (1253)
Total number of ACEs					
0	47.6 (1542)	45.0 (1332)	46.4 (1542)	53.1 (1883)	13.2 (501)
1	27.6 (895)	27.3 (808)	28.0 (929)	26.5 (940)	25.3 (960)
2	15.3 (496)	15.4 (455)	15.6 (518)	13.3 (470)	21.7 (822)
3	6.3 (204)	7.4 (219)	6.9 (229)	5.3 (188)	16.1 (610)
4	3.1 (101)	5.0 (149)	3.2 (103)	1.9 (66)	23.8 (898)

Table 3
Adverse Childhood Experiences: Correlations and Descriptive Statistics

Variables	1	2	3	4
1. Year 3 ACEs	-			
2. Year 5 ACEs	.496**	-		
3. Year 9 ACEs	.333**	.449**	-	
4. Year 15 ACEs	.317**	.381**	.384**	-
<i>M</i>	.905	1.028	.933	.767
<i>SD</i>	1.102	1.243	1.115	1.007
Range				
Potential	0-7	0-8	0-8	0-8
Actual	0-6	0-7	0-6	0-5

** p<.01.

Table 4
 Child Internalizing/Externalizing Problems: Correlations

	Y3 Anxious/ depressed	Y5 Anxious/ depressed	Y9 Anxious/ depressed	Y15 Anxious/ depressed
Y3 Anxious/ depressed (n=3230)	-			
Y5 Anxious/ depressed (n=2431)	.364**	-		
Y9 Anxious/ depressed (n=2474)	.187**	.343**	-	
Y15 Anxious/ depressed (n=2678)	.151**	.234**	.332**	-
	Y3 Withdrawn	Y5 Withdrawn	Y9 Withdrawn	Y15 Withdrawn
Y3 Withdrawn (n=3229)	-			
Y5 Withdrawn (n=2431)	.371**	-		
Y9 Withdrawn (n=2504)	.257**	.370**	-	
Y15 Withdrawn (n=2721)	.132**	.145**	.239**	-
	Y3 Aggressive	Y5 Aggressive	Y9 Aggressive	Y15 Aggressive
Y3 Aggressive (n=3229)	-			
Y5 Aggressive (n=2431)	.545**	-		
Y9 Aggressive (n=2465)	.382**	.481**	-	
Y15 Aggressive (n=2705)	.288**	.401**	.498**	-
	Y3 Destructive	Y5 Delinquent	Y9 Delinquent	Y15 Delinquent
Y3 Destructive (n=2799)	-			
Y5 Delinquent (n=2431)	.350**	-		
Y9 Delinquent (n=2501)	.246**	.316**	-	
Y15 Delinquent (n=2685)	.203**	.264**	.315**	-

Note. Y = Year; ** p<.01.

Table 5
Results of Random Intercept Cross-Lagged Panel Model

	Anxious/ Depressed	Withdrawn	Aggressive	Destructive/ Delinquent
Y5 Outcome				
β : Y3 ACEs	-.006 (.033)	.042 (.032)	.035 (.032)	.058 (.034)
Y5 ACEs				
β : Y3 Outcome	-.040 (.027)	.041 (.028)	.021 (.031)	.044 (.030)
Y9 Outcomes				
β : Y5 ACEs	.116 (.030)***	.021 (.031)	.080(.036)*	.056 (.035)
Y9 ACEs				
β : Y5 Outcome	.094 (.024)***	.018 (.031)	.019 (.034)	.006 (.033)
Y15 Outcomes				
β : Y9 ACEs	.014 (.027)	.007 (.026)	-.020 (.030)	-.021 (.031)
Y15 ACEs				
β : Y9 Outcome	.037 (.027)	.023 (.033)	.054 (.036)	-.006 (.030)

Note. Standardized coefficients and standard errors from Random Intercept Cross-Lagged Model are presented. Y = Year.

* $p < .05$. *** $p < .01$.

CHAPTER 3

Adverse Childhood Experiences and Psychological Well-being in a Rural Sample of Chinese Young Adults

Abstract

This study aimed to assess the prevalence and psychological consequences of adverse childhood experiences (ACEs) in a sample of 1,019 rural Chinese young adults who graduated from one of six high schools in 3 different provinces. A web-based survey was used to gather data on participants' health outcomes and exposure to ten conventional ACEs and seven other potential adversities. Six indicators of participants' psychological well-being were assessed: anxiety, depression, global stress, posttraumatic stress, loneliness, and suicidality. Results revealed that 75.0% of Chinese youth endorsed at least one of 10 conventional ACEs, and about 45.9% reported exposure to two or more ACEs. The most prevalent ACEs reported were physical abuse (52.3%) and domestic violence (43.2%). Among the seven other potential adversities assessed, parental absence (37.4%) and parental gambling problems (19.7%) were most prevalent. Higher cumulative ACE scores were significantly associated with poorer psychological functioning. Compared to participants with no ACEs, participants with four or more ACEs were significantly more likely to suffer from anxiety ($B = 2.73$; $CI = 1.77-3.70$), depression ($B = 4.29$; $CI = 3.21-5.36$), global stress ($B = 2.24$; $CI = 1.66-2.82$), posttraumatic stress ($OR = 4.32$; $2.51-7.45$), loneliness ($B = 1.71$; $1.24-2.17$), and suicidality ($OR = 15.46$; $CI = 7.27-32.89$). In conclusion, ACEs were prevalent among rural Chinese young adults and had deleterious effects on their psychological well-being. Further work is needed to adapt ACEs assessment practices as well as appropriate intervention and policy responses across cultures.

Keywords: Adverse childhood experiences, psychological well-being, Chinese youth, cross-cultural study

Over the past two decades, the study of adverse childhood experiences (ACEs) has added to our understanding of environmental conditions that increase the risk of morbidity and mortality in later life. ACEs usually refer to five types of child maltreatment (physical abuse, emotional abuse, sexual abuse, physical neglect, emotional neglect) and five types of household dysfunction (substance abuse, parental separation/divorce, mental illness, battered mother, criminal behavior). The seminal Adverse Childhood Experiences Study (Felitti et al., 1998) and many subsequent investigations in the U.S. have revealed that ACEs are prevalent and interrelated, and that there is a dose-response relationship between the number of ACEs individuals report and their likelihood of poor health outcomes (e.g., Anda et al., 2002; Hughes et al., 2017; Korkeila et al., 2004; Merrick, Ford, Ports, & Guinn, 2018).

International interest in ACEs has also been on the rise in recent years. Replicating seminal findings from the U.S., researchers from many western, developed countries have found that adverse childhood experiences are prevalent and deleterious to physical, mental and behavioral health (Barboza Solís, et al., 2015; Bellis, Lowey, Leckenby, Hughes, & Harrison, 2014; Cuijpers, et al., 2011; Faravelli, et al., 2014; Haatainen, et al., 2003; Honkalampi, et al., 2005; Müller, et al., 2015). Scholarship has also begun to emerge from developing countries such as South Africa, Uganda, the Philippines, and China, and these studies also have confirmed that ACEs are common and consequential (Benjet, 2010; Bruwer et al., 2014; Okello, De Schryver, Musisi, Broekaert, & Derluyn, 2014; Slopen et al., 2010; Ramiro, Madrid & Brown, 2010; Ding, Lin, Zhou, Yan, & He, 2014; Lee et al., 2011; Xiao, Dong, Yao, Li, & Ye, 2008).

ACEs Research in China

Some studies have retrospectively assessed the prevalence and consequences of ACEs in Chinese adults. For example, a study of 2,073 Chinese medical college students by Xiao et al. (2008) in Anhui province found that 68.9% of participants reported at least one of ten typical

ACEs; the most prevalent ACEs were physical neglect (26.9%), physical abuse (26.7%), and household mental illness (23.0%). In another study of 189 adult methamphetamine users, Ding and colleagues (2014) found that 50.8% participants reported at least one of eight ACEs, and the most prevalent ACEs were household substance abuse (22.7%), emotional abuse (22.2%), and sexual abuse (13.8%). Also, a study of 5,201 metropolitan adults in Beijing and Shanghai found that 31.0% of respondents reported at least one of twelve family childhood adversities, and the most prevalent childhood adversities were parental death (11.1%), parental loss other than death (9.5%), and physical abuse (8.9%) (Lee et al., 2011). Additionally, other studies in Chinese have indicated that around 45% to 77% of respondents reported at least one ACE, and the most prevalent ACEs were child physical and emotional abuse and neglect (Cui et al., 2013; Fan et al., 2011; Guo, Cao, & Cui, 2014; Ji & Wang, 2017; Ma, Dai, Ru, Liu, & Liu, 2013; Nie et al., 2015). These findings indicate that ACEs prevalence rates have varied widely in China, which may due to study differences in measurement protocols and sample populations.

While prevalence rates have varied, Chinese ACE studies have consistently shown that ACEs are associated with an array of poor health-related outcomes in adulthood. For example, extending a long line of research in the United States, studies in China have shown that increased ACE exposure is associated with poor physical health outcomes such as high blood pressure as well as respiratory and digestive problems (Nie et al., 2015). Various mental health impacts also have been detected earlier in the life course, including aggressive behaviors, interpersonal sensitivity, and poor coping styles (Cui et al., 2013; Fan et al., 2011; Guo, Cao, & Cui, 2014; Ma, Dai, Ru, Liu, & Liu, 2013).

Despite the emergence of ACE research in China, further study is needed to address significant limitations in this literature. To begin, most studies of ACEs in Chinese samples have not been published in journals that meet conventional standards for high scientific

quality. As of this writing, only three studies of ACEs in China have been published in ranked journals with known impact factors (Ding et al., 2014; Lee et al., 2011; Xiao et al., 2008). Moreover, most ACEs studies in China adopted the 10 typical ACEs measure. However, in addition to the 10 ACEs that have received the most scientific attention, researchers have acknowledged the need to investigate other common adversities that may improve our understanding of ACEs and their consequences (Cronholm et al., 2015; Finkelhor et al., 2013; Finkelhor et al., 2015; Mersky, Janczewski, & Topitzes, 2017; Wade et al., 2014). The imperative to explore the prevalence and consequences of other ACEs is especially important considering that the conventional ACE framework does not include indicators of adversity that occur outside the household (Mersky et al., 2017). For instance, studies by Finkelhor et al. (2015) and Mersky et al. (2017) have found that adding the new adversity items such as peer victimization and community violence can significantly improve the prediction of psychological well-being. Moreover, the original ACE framework may omit certain adversities that are especially prevalent and consequential in other nations. Thus, research is needed to determine whether expanded ACE measures can enhance our capacity to estimate the prevalence and consequences of ACEs in China.

The Current Study

The current study examines the prevalence and psychological consequences of adverse childhood experiences among a group of rural Chinese young adults. Specifically, this research aims to (1) assess the prevalence of conventional ACEs and other potential adversities, and (2) test associations between cumulative exposure to ACEs and salient indicators of psychological functioning in early adulthood. On a broader scale, the study has the potential to increase knowledge and awareness of the mental health implications of ACEs in China, which may have broader implications for prevention, intervention, and public health policy. This paper addresses two main research questions:

1. What is the prevalence of conventional ACEs and other potential adversities in a sample of Chinese youth?
2. Does exposure to a greater number of ACEs increase the risk of poor psychological outcomes among Chinese youth?

Methods

Participants and Research Design

For this study, 7,986 rural high school graduates were recruited from six high schools in 3 different provinces of China (Hebei, Anhui and Jiangsu). In each of the participating high schools, email addresses were collected from students in the first, second, and third year of high school. Unlike the United States, where most students attend high school for four years, Chinese students typically attend high school for three years. Three different survey waves were scheduled, one for each graduating class. Once students turned 18 years old and graduated from high school, a web-based survey was distributed via Qualtrics (Qualtrics, Provo, UT) to participants through their private email accounts. Participation was voluntary and confidential, and no personal identifying information was collected. Survey respondents received a 25 Yuan (approximately US\$3.80) Amazon gift card after completing the survey. The study was approved by administrators of the six high schools and the institutional review board (IRB) at the University of Wisconsin-Milwaukee.

From 2016 to 2018, one survey wave was conducted each year. Pre-notifications and reminders were also used before and after the invitation emails. Nearly 24% of the sample (n = 1,888) could not be reached because the emails were undeliverable. Of the 6,098 individuals to whom an email could be delivered, 1,091 completed the questionnaire, yielding a net response rate of 18%.

Measures

The survey asked participants about their family background, including ACEs, as well as questions about their physical health, mental health, risk behaviors, social relationships and academic performance. A back-translation method was used to translate the survey into Mandarin Chinese. The first author translated the English survey into Mandarin, and then three independent raters translated the survey from Mandarin to English. Discrepancies between different translations were discussed by all translators until a satisfactory version was reached. Before the final version of survey was sent to the study participants, pre-testing and cognitive interviewing were also implemented among 20 Chinese young adults. Specific measures used in this study are described as below:

Adverse childhood experiences.

Participants completed the Childhood Experiences Survey (CES; Mersky et al., 2017), a measure of 10 conventional ACEs (physical abuse and neglect, emotional abuse and neglect, sexual abuse, domestic violence, household mental health problem, household substance abuse, household incarceration, parental divorce or separation) and seven other potential adversities (family financial hardship, food insecurity, homelessness, peer victimization, parental absence, death of parent or sibling, violent crime victimization). Previous research has shown that the CES demonstrated good internal consistency, test-retest reliability, and predictive validity in a low-income sample of women (Mersky et al., 2017). For this study, the CES was modified for a Chinese sample in two ways. First, the question about homelessness was omitted because during adolescence, most participants attended boarding school. Second, parental gambling was added to the assessment because research indicates that gambling is a prevalent and consequential household problem in China (Loo, Raylu, & Oei, 2008). The following question was added to assess household gambling problems: “Before age 18, did you live with parent(s) who had a gambling problem?” Participants who

indicated that their parent(s) gambled were coded 1; all other participants were coded 0. For all remaining operational definitions and coding methods, please see Mersky et al. (2017).

Anxiety symptoms.

Anxiety symptoms were measured by the Generalized Anxiety Disorder 7-item (GAD-7) scale, which is a brief screen for generalized anxiety disorder (Spitzer, & Kroenke, Williams, & Lowe, 2006). The GAD-7 scale also has solid internal consistency ($\alpha = 0.92$), test-retest reliability ($r = 0.83$), and convergent validity (Spitzer et al., 2006). The Chinese version of GAD-7 has been validated among Chinese people with epilepsy (Tong, An, McGonigal, Park & Zhou, 2015). In this sample, the GAD-7 also demonstrated excellent internal consistency ($\alpha = 0.89$). A total score of anxiety was calculated by summing across all scale items.

Depressive Symptoms.

Depressive symptoms were measured using the Patient Health Questionnaire (PHQ-9), which is a widely used screen that has excellent internal reliability ($\alpha = 0.89$) and good criterion-related validity (Huang, Chung, Kroenke, Delucchi, & Spitzer, 2006; Kroenke, Spitzer, & Williams, 2001). Several studies have shown that the Chinese version of PHQ-9 is a valid and reliable tool for screening depression among Chinese people (Chen et al., 2013; Du, Yu, Ye, & Chen, 2017; Wang et al., 2014; Zhang et al., 2013). The PHQ-9 also demonstrated good internal consistency in this study sample ($\alpha = 0.86$). A total score was calculated by summing all scale items.

Global Perceived Stress.

Stress was measured via the 4-item form of Perceived Stress Scale (PSS-4), a widely-used and well validated instrument for measuring global perceived stress (Cohen & Williamson, 1988). The measure has also been validated in a study of Chinese outpatient clinic patients (Leung, Lam, & Chan, 2010). Most research has shown that the internal

consistency of PSS-4 is acceptable, though some studies have reported alpha reliabilities of less than .70 (Lee, 2012). In the present sample, the PSS-4 also showed acceptable internal consistency ($\alpha = 0.74$). A total score of stress was calculated by summing across the 4 items.

Posttraumatic Stress.

Posttraumatic stress was measured using the 4-item Primary Care PTSD Screen (PC-PTSD) instrument. This brief screen is a psychometrically sound screen for PTSD with comparable operating characteristics to other screens for mental disorders (Prins et al., 2003). This scale also has been shown to have sound psychometric properties, including good test-retest reliability (i.e., $r = 0.83$; Prins et al., 2003). It also has been validated in China study (Li et al., 2019). Participants who answered “yes” to any three items were coded “positive” for probable posttraumatic stress disorder.

Loneliness.

Loneliness was measured using total scores on the 4-item short form of UCLA Loneliness Scale, which is a commonly used measure to assess subjective feelings of loneliness or social isolation (Russell, Peplau, & Cutrona, 1980). Researchers have demonstrated that the 4-item UCLA Loneliness Scale has acceptable internal consistency ($\alpha = 0.75$) (Russell, 1980). The psychometrics of the UCLA Loneliness Scale have not been tested in China. In the current study, the measure had good internal consistency ($\alpha = 0.84$).

Suicidal Ideation.

Suicidal ideation was measured by a single question: During the past 12 months, did you ever seriously consider attempting suicide? An affirmative response to this question indicated suicide intention (1 = yes; 0 = no).

Covariates.

Demographic information collected from the participants was used to measure several covariates, including participant sex (0 = female; 1 = male). The educational level of

participants' parents was coded ranging from 1 (elementary school or less) to 6 (some college or more). In addition, participants provided information about their mother's and father's employment status (1 = full-time employed; 2 = part-time employed; 3 = unemployed). An ordinal measure of household socioeconomic status was created using the following item: "Please imagine a ten-step ladder where on the bottom (the first step), stand the poorest people, and on the highest step (the tenth step), stand the richest people. On which step is your family today?" This economic ladder question has also been validated in several studies to measure poverty or socioeconomic status (Koczan, 2016; Stillman, Gibson, McKenzie, Rohorua, 2012). Participants also reported the number of siblings they had (0; 1; 2; 3 or more) and if parent had been a migrant worker (1 = yes; 0 = no).

Data Analysis

Statistical analyses were performed by SPSS version 23. Descriptive analyses were completed to describe the sample demographics and the measures of ACEs and psychological problems. Adjusted associations between ACEs and an array of outcomes (anxiety, depression, perceived stress, loneliness, posttraumatic stress, and suicide ideation) were tested using multivariate regression analysis. The regression estimators applied depended on the distribution of the outcomes. Dichotomies were analyzed with logistic regression, while continuous measures were analyzed with Ordinary Least Squares (OLS) regression. All multivariate models controlled for gender, parent education level, parent employment status, family economic status, and number of siblings.

Results

Results showed that 53% of participants were male and their mean age was 18.6 (SD = 0.8). The average educational level for participants' fathers was 3.1 (SD = 1.5), and for participants' mothers was 2.5 (SD = 1.5). Results (not shown) indicated that 23.1 % of the participants' fathers and 15.2 % of their mothers completed high school or above education.

Approximately 12% of fathers and 27% of mothers were unemployed. The mean score on the socioeconomic ladder question was 4.1 (SD = 1.4); nearly two-thirds (65%) of participants reported that their families were below the fifth rung of the ladder. Respondents indicated that 71% one or more of their parents had been a migrant worker. The average number of siblings for participants was 1.0 (SD = 0.9).

For participants' psychological outcomes, the mean score of anxiety was 5.6 (SD = 4.2); the mean score of depression was 5.9 (SD = 4.8); the mean score of perceived stress was 6.1 (SD = 2.7); and the mean score of loneliness was 3.3 (SD = 2.1). Moreover, 21.6% of participants met the cutoff for probable posttraumatic stress disorder, and 14.2% reported suicidal ideation (see Table 6).

(Table 6 Inserted Here)

The prevalence of 10 conventional ACEs and seven other adversities are described in Table 7. Study results revealed that the most prevalent ACEs reported were physical abuse (52.3%) and domestic violence (43.2%). Also, 75% of Chinese youth endorsed at least one of the 10 conventional ACEs, about 46% exposed to two or more ACEs, and 11.2% experienced four or more ACEs in their childhood. Among other new adversities assessed, parental absence (37.4%), parental gambling (19.7%), and death of parent or sibling (14.3) were most prevalent, while food insecurity (3.2%) and peer victimization (3.5%) were the least prevalent.

(Table 7 Inserted Here)

Table 8 presents results from analyses that tested relations between a cumulative ACE measure and psychological outcomes. Results showed that there was a dose-response relationship between ACEs and psychological outcomes, meaning that the greater the number of ACEs the more likely that psychological problems were reported. To illustrate, compared to participants with no ACEs, participants with four or more ACEs were significantly more

likely to suffer from anxiety ($B = 2.73$; $CI = 1.77-3.70$), depression ($B = 4.29$; $CI = 3.21-5.36$), perceived stress ($B = 2.24$; $CI = 1.66-2.82$), loneliness ($B = 1.71$; $1.24-2.17$), posttraumatic stress ($OR = 4.32$; $2.51-7.45$), and suicide ideation ($OR = 15.46$; $CI = 7.27-32.89$).

(Table 8 Inserted Here)

Discussion

This study is the first to describe the prevalence and consequences of conventional ACEs and other potential adversities in a rural sample of young adults in China. Results indicated that 75% of participants reported at least one of 10 conventional ACEs and 46% reported exposure to multiple ACEs. These prevalence figures are higher than previously published estimates in China (e.g., Ding et al., 2014; Lee et al., 2011; Xiao et al., 2008) and in the general U.S. population (Green et al., 2010; Merrick et al., 2018), and they are more comparable to rates that have been documented in low-income samples in the U.S. (Chung et al., 2010; Mersky et al., 2017; Topitzes, Pate, Berman, & Medina-Kirchner, 2016).

Results showed that, among 10 indicators of adversity that are commonly assessed in the ACE literature, physical abuse and domestic violence were the most prevalent in this sample. The previous estimates of physical abuse in other ACEs studies in China have varied widely, ranging from 8.9% to 26.9% (Lee et al., 2011; Fan et al., 2011). Besides, Ji and Finkelhor (2015) have completed a meta-analysis of child physical abuse prevalence in China, and they concluded that prior to age 18, the lifetime prevalence of any child physical abuse in China was around 36.6%, which was significantly higher than the average estimated rate of physical abuse in other international samples. In the current study, over half of respondents (52.3%) reported that a parent or adult in the home had hit, beat, kick, or physically hurt them, signifying child physical abuse. The higher prevalence reported here, as compared to other China ACEs research and Ji and Finkelhor's analysis, may be related to the current study's

more rural composition. The findings may suggest that corporal punishment and physical abuse is more common in rural Chinese households than urban Chinese households, and that parenting norms differ between rural and urban Chinese parents (Yue et al., 2016).

In addition, 43.2% of participants reported parental domestic violence, far exceeding previous prevalence estimates of domestic violence in China. For example, other ACE studies have reported domestic violence rates ranging from 1.9% to 15.7% (Ding et al., 2014; Fan et al., 2011; Lee et al., 2011; Xiao et al., 2008). The higher prevalence observed in the current study may be due to the more rural and economically disadvantaged composition of the sample. Research has shown that Chinese women are at increased risk of domestic violence if they are of low educational and socioeconomic status or grew up in rural areas (Parish, Wang, Laumann, Pan, & Luo, 2004; Tang & Lai, 2008).

The high rate of household domestic violence witnessed by respondents in this study is especially noteworthy when juxtaposed with the low rate of reported divorce/separation (8.0%). Previous research suggests that many Chinese parents avoid divorce/separation due to concerns about social stigma, economic hardship, and fears of harming their children or losing them altogether (Chen & Shu, 2017; Platte, 1988). It is possible that, for many adults, these concerns override the threat of domestic violence. That is, domestic violence may have been prevalent in the sample, in part, because divorce/separation is uncommon.

It should also be acknowledged that, apart from physical abuse and domestic violence, the prevalence of most other typical ACEs was low as compared to U.S. estimates. In a recent synthesis of U.S. data collected through the Behavioral Risk Factor Surveillance System, Merrick et al. (2018) reported that the prevalence for emotional abuse, substance abuse, and parental mental health problems was 34.4%, 27.6%, and 16.5%, respectively (Merrick et al., 2018). By comparison, the prevalence of these ACEs in the present study was as follows: emotional abuse (6.0%), substance abuse (13.0%) and parental mental health problems

(8.5%). Further research needs to determine if the rates of these ACEs are truly lower than they are in the U. S. and other nations or if alternative assessment items are needed to generate valid estimates of ACEs in China.

Among the seven other adversities measured in this study, parental absence (37.4%) and frequent gambling (19.7%) were the most prevalent. The high rate of parental absence may be linked to the rapid development of the Chinese economy in the past three decades, which has motivated many rural poor to seek economic opportunities in urban economic centers. It has been estimated that during this period nearly 290 million adults have moved from rural agricultural areas to metropolitan areas (National Bureau of Statistics, 2019). Consequently, one in three children in rural China lives without one or both parents (All-China Women's Federation, 2013). The present findings also reinforce prior research that indicates gambling is a prevalent social problem in China. For example, Zhao and Peng (2010) reported that, in a village in Anhui province, nearly 60% of adults gambled and 7% did so on a daily basis. Research has also shown that parental gambling is consequential. Studies have linked parental gambling to an increased risk of suicide attempts of Chinese youth (Xing et al., 2010) and to an increased risk of other ACEs such as child neglect, domestic violence, financial problems, and family conflict (Abbott, Cramer, & Sherrets, 1995; Dowling, Smith, & Thomas, 2009; Hodgins, Shead, & Makarchuk, 2006; Kalischuk, Nowatzki, Cardwell, Klein, & Solowoniuk, 2006; Subramaniam, Chong, Satghare, Browning, & Thomas, 2017; Suomi et al., 2013).

This study confirmed that, controlling for demographic characteristics, exposure to a greater number of ACEs was significantly associated with elevated anxiety, depression, perceived stress, and loneliness scores as well as an increased risk of PTSD, and suicidal ideation. The findings are consistent with prior research. For instance, many studies in the Western nations have demonstrated that exposure to ACEs can significantly increase the risk

for anxiety and depression (De Venter, Demyttenaere, & Bruffaerts, 2013; Hughes et al., 2017). Studying a group of urban, minority young adults in Chicago, Mersky and colleagues (2013) found that ACEs were significantly associated with anxiety and depression symptoms, and there was a strong, dose–response relationship between ACEs score and anxiety, depression outcomes.

Few studies have examined the association between ACEs and perceived stress and loneliness, though a recent study of 305 adults in the United States found that higher ACEs were significantly related to increased stress and loneliness (Wong, Dirghangi and Hart, 2019). A more robust body of literature has examined the relationship between ACEs and posttraumatic stress. LeardMann et al. (2010) found that ACEs were significantly related to post-deployment PTSD in U.S. Marines. Swopes et al. (2013) also confirmed that higher ACEs significantly increase the risk of PTSD symptoms.

Last, many studies have examined the relationship between ACEs and suicidality (e.g., Dube et al., 2001; Thompson et al., 2012). For example, using data from the original ACE Study, Dube et al. (2001) uncovered a strong, graded relationship between ACEs and attempted suicide. For example, the adjusted odds ratio of ever attempting suicide among persons with 7 or more ACEs was 31.1 (95% CI, 20.6-47.1). In the current study, the adjusted odds ratio of suicidal intention among people with 4 or more ACEs was 15.46 (95% CI, 7.27 - 32.89). Research has shown that ACEs are among the leading environmental causes of death (Felitti et al., 1998; Brown et al., 2009). The consistent consequences of ACEs on mental health problems also underscore the universality of ACEs consequences and the importance of screening and intervention across cultures.

Limitations

There are limitations to this study that should be considered when interpreting the findings. First, the study sample was restricted to high school graduates from rural areas of

China. Thus, the study results may not be generalizable to Chinese children in urban settings or to other international populations. Second, this study mainly relied on self-report data, which have well-known limitations (Hardt & Rutter, 2004). It is possible, for example, that their ACEs and psychological problems were both underreported because of social desirability. Third, although seven new potential adversities were examined in this study, there may be other potential adversities that were not asked in this study. Fourth, this study is cross-sectional and, therefore, causality cannot be inferred. Finally, the study response rate is relatively low, which makes it another limitation of this study.

Implications & Future Directions

As the first investigation focusing on rural Chinese young adults' ACEs exposure and consequences, this study has significant implications for future research, policy, and practice in China. First, despite rapid scientific growth in China (Veugelers, 2017), research in the social and behavioral sciences is still limited. For example, no nationally representative study of ACEs generally, or child maltreatment specifically, has been conducted. Future research on ACEs, especially nationally representative studies, may help learn about the needs of the Chinese population overall as well as the needs of particular groups (e.g., rural households). The national research outcomes may help translate evidence into culturally appropriate prevention and intervention programs and services in China.

The current study also points to implications for policy. Although China has a constitution which states that children and youth are protected by law, and that child maltreatment is not permissible (Article 49), the constitution does not clearly define child maltreatment or stipulate what the penalties are if caregivers maltreat their children. Moreover, another law, Article 12, states that child custody may be deprived if parents abuse their children. However, there are no clear guidelines for residential care of children after they have been removed from their caregivers' custody. China does have a foster care system,

but it mainly serves orphans and abandoned children rather than abused children (Xu, Bright, & Ahn, 2018). In recent years, the Chinese government has taken steps to build a national child protection system. For example, in 2011 the government launched the National Program for Child Development. In 2013, China's ministry of Civic Affairs also initiated a pilot child protection program. However, these child protection programs mainly serve vulnerable and disadvantaged children rather than abused children (Man, Barth, Li, & Wang, 2017). China also lacks a mandatory reporting system for suspected child maltreatment. Future work in this area should address these gaps by translating research findings into child protection policies and programs.

Besides the above suggested changes at macro level, specific prevention and intervention strategies should also be implemented to reduce or mitigate the impact of ACEs on rural Chinese children's health. Considering that the public health system in China doesn't provide a platform for rural caregivers to learn about optimal parenting, Luo and colleagues suggested that the Health and Family Planning Commission (HFPC) can take a role in providing parenting education in rural China. This recommendation may be feasible given that HFPC is experienced in conducting village outreach and running informational campaigns in rural areas (Luo et al., 2017), and its mandate has been changed in 2016 from enforcing China's one-child-policy to improving children's quality of life. Along with parenting education, HFPC could also offer professional home visiting services and other prevention services for families at high risk for child maltreatment and other adversities. Since most ACEs take place in the home environment, home visiting services like this have the potential to enhance positive parenting and promote nurturing home environment.

Local health care providers could also collaborate with HFPC and school social workers or counselors to intervene when child maltreatment is suspected and develop intervention plans to protect children and stabilize families. However, at present, school social work is

still in its nascent stage in China (Levine & Zhu, 2010). Although some urban schools in China have counseling offices, most children in rural schools rarely have access to professional school counselor or community-based mental health services (Leuwerke & Shi, 2010). Considering that a substantial proportion of rural Chinese children attend boarding schools, there is a great need for advancements in school-based counseling to address the needs of children who have been exposed to significant adversity and trauma.

References

- Abbott, D. A., Cramer, S. L., & Sherrets, S. D. (1995). Pathological gambling and the family: Practice implications. *Families in Society*, 76(4), 213-219.
- All-China Women's Federation. (2013). 我国农村留守儿童、城乡流动儿童状况研究报告 [National survey report on the situation of left-behind children and migrant children in China]. (Beijing).
- Anda, R. F., Whitfield, C. L., Felitti, V. J., Chapman, D. P., Edwards, V. J., Dube, S. R., & Williamson, D. F. (2002). Adverse childhood experiences, alcoholic parents, and later risk of alcoholism and depression. *Psychiatric Services*, 53, 1001-1009.
- Barboza Solís, C., Kelly-Irving, M., Fantin, R., Darnaudéry, M., Torrisani, J., Lang, T., & Delpierre, C. (2015). Adverse childhood experiences and physiological wear-and-tear in midlife: Findings from the 1958 British birth cohort. *Proceedings of the National Academy of Sciences*, 112(7), E738-E746.
- Bellis, M. A., Lowey, H., Leckenby, N., Hughes, K., & Harrison, D. (2014). Adverse childhood experiences: Retrospective study to determine their impact on adult health behaviors and health outcomes in a UK population. *Journal of Public Health (Oxford, England)*, 36(1), 81–91.
- Benjet, C. (2010). Childhood adversities of populations living in low-income countries: Prevalence, characteristics, and mental health consequences. *Current Opinion in Psychiatry*, 23, 356–362.
- Brown, D. W., Anda, R. F., Tiemeier, H., Felitti, V. J., Edwards, V. J., Croft, J. B., & Giles, W. H. (2009). Adverse childhood experiences and the risk of premature mortality. *American journal of preventive medicine*, 37(5), 389-396.
- Bruwer, B., Govender, R., Bishop, M., Williams, D. R., Stein, D. J., & Seedat, S. (2014). Association between childhood adversities and long-term suicidality among South

- Africans from the results of the South African Stress and Health study: A cross-sectional study. *BMJ Open*, 4(6), e004644–e004644.
- Chen, J., & Shu, X. (2017). Gender and divorce in China. *Asia Dialogue*. Retrieved from <https://theasiadialogue.com/2017/10/09/gender-and-divorce-in-china/>
- Chen, L., Wang, L., Qiu, X., Yang, X., Qiao, Z., Yang, Y., & Liang, Y. (2013). Depression among Chinese university students: Prevalence and socio-demographic correlates. *PloS One*, 8: e58379.
- Chung, E. K., Nurmohamed, L., Mathew, L., Elo, I. T., Coyne, J. C., & Culhane, J. F. (2010). Risky health behaviors among mothers-to-be: The impact of adverse childhood experiences. *Academic Pediatrics*, 10(4), 245-251.
- Cohen, S., & Williamson, G. (1988). Perceived stress in a probability sample of the United States. In S. Spacapan, & S. Oskamp (Ed.), *The Social Psychology of Health: Claremont Symposium on Applied Social Psychology* (pp. 31-67). Newbury Park, CA: Sage.
- Cronholm, P. F., Forke, C. M., Wade, R., Bair-Merritt, M. H., Davis, M., Harkins-Schwarz, M., & Fein, J. A. (2015). Adverse childhood experiences: Expanding the concept of adversity. *American Journal of Preventive Medicine*, 49(3), 354-361.
- Cui, N., Cao, F., Li, Y., Long, Z., Li, J., & Dong, F. (2013). 医学新生的儿童期不良经历的累积效应与攻击行为[The accumulative effect of adverse childhood experiences and aggressive behaviors among medical college students]. *Chinese Mental Health Journal*, 27(3), 213-214. [In Chinese]
- Cuijpers, P., Smit, F., Unger, F., Stikkelbroek, Y., Ten Have, M., & de Graaf, R. (2011). The disease burden of childhood adversities in adults: A population-based study. *Child Abuse & Neglect*, 35(11), 937-945.

- Department of Health. (1985). Recent Life Events Questionnaire. Retrieved from <http://www.kenttrustweb.org.uk>
- De Venter, M., Demyttenaere, K., & Bruffaerts, R. (2013). The relationship between adverse childhood experiences and mental health in adulthood. A Systematic literature review. *Tijdschrift Voor Psychiatrie*, *55*(4), 259-268.
- Ding, Y., Lin, H., Zhou, L., Yan, H., & He, N. (2014). Adverse childhood experiences and interaction with methamphetamine use frequency in the risk of methamphetamine associated psychosis. *Drug and Alcohol Dependence*, *142*, 295-300.
- Dowling, N., Smith, D., & Thomas, T. (2009). The family functioning of female pathological gamblers. *International Journal of Mental Health and Addiction*, *7*(1), 29-44.
- Du, N., Yu, K., Ye, Y., & Chen, S. (2017). The validity study of Patient Health Questionnaire-9 items for internet screening in depression among Chinese University students. *Asia-Pacific Psychiatry*, *9*(3). doi:10.1111/appy.12266
- Dube, S. R., Anda, R. F., Felitti, V. J., Chapman, D. P., Williamson, D. F., & Giles, W. H. (2001). Childhood abuse, household dysfunction, and the risk of attempted suicide throughout the life span: Findings from the Adverse Childhood Experiences Study. *Pediatrics*, *111*, 564-572.
- Fan, Y., Pan, H., Zhang, Z., Zhang, N., Wang, C., & Ye, D. (2011). 医学生儿童时期不良经历与应付方式的关联性分析 [Correlative analysis between ACEs and coping styles among medical college students]. *Chinese Journal of School Health*, *32*(7), 774-776. [In Chinese]
- Faravelli, C., Castellini, G., Fioravanti, G., Lo Sauro, C., Pietrini, F., Lelli, L., & Ricca, V. (2014). Different childhood adversities are associated with different symptom patterns in adulthood. *Psychotherapy and Psychosomatics*, *83*(5), 320-321.

- Feinstein, L., & Sabates, R. (2006). *Predicting adult life outcomes from earlier signals: Identifying those at risk*. London: Institute of Education, University of London.
- Felitti, V. J., Anda, R. F., Nordenberg, D., Williamson, D. F., Spitz, A. M., Edwards, V., Koss, M. P., & Marks, J. S. (1998). Relationship of childhood abuse and household dysfunction to many of the leading causes of death in adults: The Adverse Childhood Experiences (ACE) Study. *American Journal of Preventive Medicine, 14*(4), 245-258.
- Finkelhor, D., Shattuck, A., Turner, H., & Hamby, S. (2013). Improving the adverse childhood experiences study scale. *JAMA Pediatrics, 167*, 70-75.
- Finkelhor, D., Shattuck, A., Turner, H., & Hamby, S. (2015). A revised inventory of adverse childhood experiences. *Child Abuse & Neglect, 48*, 13-21.
- Green, J. G., McLaughlin, K. A., Berglund, P. A., Gruber, M. J., Sampson, N. A., Zaslavsky, A. M., & Kessler, R. C. (2010). Childhood adversities and adult psychiatric disorders in the national comorbidity survey replication I: associations with first onset of DSM-IV disorders. *Archives of General Psychiatry, 67*(2), 113-123.
- Guo, W., Cao, F., & Cui, N. (2014). 医学生人际关系敏感与儿童期不良经历: 负性情绪的关系模型 [Interpersonal sensitivity and adverse childhood experiences among medical college students: The mediating role of negative emotions]. *Chinese Journal of Practical Nursing, 30*(21), 1-5. [In Chinese]
- Haatainen, K. M., Tanskanen, A., Kylmä, J., Honkalampi, K., Koivumaa-Honkanen, H., Hintikka, J., & Viinamäki, H. (2003). Gender differences in the association of adult hopelessness with adverse childhood experiences. *Social Psychiatry and Psychiatric Epidemiology, 38*(1), 12-17.

- Hardt, J., & Rutter, M. (2004). Validity of adult retrospective reports of adverse childhood experiences: review of the evidence. *Journal of child psychology and psychiatry*, 45(2), 260-273.
- Hodgins, D. C., Shead, W., & Makarchuk, K. (2006). Relationship satisfaction and psychological distress among concerned significant others of pathological gamblers. *The Journal of Nervous and Mental disease*, 195(1), 65-71.
- Honkalampi, K., Hintikka, J., Haatainen, K., Koivumaa-Honkanen, H., Tanskanen, A., Viinamaki, H., & Viinamäki, H. (2005). Adverse childhood experiences, stressful life events or demographic factors: which are important in women's depression? A 2-year follow-up population study. *The Australian and New Zealand Journal of Psychiatry*, 39(7), 627-632.
- Hughes, K., Bellis, M. A., Hardcastle, K. A., Sethi, D., Butchart, A., Mikton, C., ... & Dunne, M. P. (2017). The effect of multiple adverse childhood experiences on health: a systematic review and meta-analysis. *The Lancet Public Health*, 2(8), e356-e366.
- Ji, K., & Finkelhor, D. (2014). A meta-analysis of child physical abuse prevalence in China. *Child Abuse & Neglect*, 43, 61-72.
- Ji, S., & Wang, H. (2017). 大学生儿童时期不良经历近期生活事件与执行功能的关系 [Study on the relationships among adverse childhood experiences, life events and executive function of college students]. *Chinese Journal of School Health*, 38(12), 1831-1834. [In Chinese]
- Kalischuk, R. G., Nowatzki, N., Cardwell, K., Klein, K., & Solowoniuk, J. (2006). Problem gambling and its impact on families: A literature review. *International Gambling Studies*, 6(1), 31-60.

- Koczan. (2016). Being poor, feeling poorer: Inequality, poverty and poverty perceptions in the Western Balkans. Retrieved from <https://www.imf.org/external/pubs/ft/wp/2016/wp1631.pdf>
- Korkeila, K., Kivelä, S. L., Suominen, S., Vahtera, J., Kivimäki, M., Sundell, J., & Koskenvuo, M. (2004). Childhood adversities, parent-child relationships and dispositional optimism in adulthood. *Social Psychiatry and Psychiatric Epidemiology*, 39(4), 286–92.
- Kroenke, K., Spitzer, R., & Williams, W. (2001). The PHQ-9: Validity of a brief depression severity measure. *Journal of General Internal Medicine*, 16, 606-616.
- LeardMann, C. a, Smith, B., & Ryan, M. A. (2010). Do adverse childhood experiences increase the risk of postdeployment posttraumatic stress disorder in US Marines? *BMC Public Health*, 10, 437.
- Lee, E. H. (2012). Review of the psychometric evidence of the perceived stress scale. *Asian Nursing Research*, 6(4), 121-127.
- Lee, S., Guo, W. J., Tsang, A., He. Y. L., Huang, Y. Q., Zhang, M. Y., Liu, Z. R., Shen, Y. C., & Kessler, R. C. (2011). The prevalence of family childhood adversities and their association with first onset of DSM-IV disorders in metropolitan China. *Psychological Medicine*, 41(1), 85-96.
- Levine, K. A., & Zhu, K. (2010). The changing context of China: Emerging issues for school social work practice. *International Social Work*, 53(3), 339-352.
- Leung, D. Y. P., Lam, T. H., & Chan, S. S. C. (2010). Three versions of Perceived Stress Scale: Validation in a sample of Chinese cardiac patients who smoke. *BMC Public Health*, 10, 513.

- Leuwerke, W., & Shi, Q. (2010). The practice and perceptions of school counsellors: A review from urban China. *International Journal for the Advancement of Counselling*, 32, 75-89.
- Li, J., Zhang, W., Chen, W., Yuan, H., Zhang, S., Tian, M., & Qu, Z. (2019). Application of the Chinese version of Primary Care PTSD screen for DSM-5 (PC-PTSD-5) in Children. *Journal of Affective Disorders*, 254, 109-114.
- Luo, R., Jia, F., Yue, A., Zhang, L., Lyu, Q., Shi, Y., Yang, M., Medina, A., Kotb, S., & Rozelle, S. (2017). Passive parenting and its association with early child development. *Early Child Development and Care*, 1-15.
- Ma, J., Dai, J., Ru, J., Liu, W., & Liu, J. (2013). 医学生心理健康状况与儿童期不良经历的关系探讨 [Study on the relationship between adult mental health status and adverse childhood experiences among medical college students]. *Chinese Journal of Disease Control & Prevention*, 17(3), 218-221. [In Chinese]
- Mc Elroy, S., & Hevey, D. (2014). Relationship between adverse early experiences, stressors, psychosocial resources and wellbeing. *Child Abuse & Neglect*, 38(1), 65–75.
- Man, X., Barth, R. P., Li, Y. E., & Wang, Z. (2017). Exploring the new child protection system in Mainland China: How does it work? *Children and Youth Services Review*, 76, 196-202.
- Mersky, J. P., Janczewski, C. E., & Topitzes, J. (2017). Rethinking the measurement of adversity: Moving toward second-generation research on adverse childhood experiences. *Child Maltreatment*, 22(1), 58-68.
- Mersky, J. P., Topitzes, J., & Reynolds, A. J. (2013). Impacts of adverse childhood experiences on health, mental health, and substance use in early adulthood: A cohort study of an urban, minority sample in the U.S. *Child Abuse & Neglect*, 37, 917-925.

- Merrick, M.T., Ford, D.C., Ports, K. A., & Guinn, A. S. (2018). Prevalence of Adverse Childhood Experiences From the 2011-2014 Behavioral Risk Factor Surveillance System in 23 States. *JAMA Pediatrics*, *172*(11), 1038-1044.
- Müller, M., Vandeleur, C., Rodgers, S., Rössler, W., Castelao, E., Preisig, M., & Ajdacic-Gross, V. (2015). Childhood adversities as specific contributors to the co-occurrence of posttraumatic stress and alcohol use disorders. *Psychiatry Research*, 1–6.
- National Bureau of Statistics. (2019). 2018 农民工监测调查报告[2018 Annual survey of migrant workers]. Retrived from http://www.stats.gov.cn/tjsj/zxfb/201904/t20190429_1662268.html
- Nie, J., Yu, H., Wang, Z., Wang, L., Han, J., Wang, Y., Du., Y., & Shen, M. (2015). 儿童期不良经历与成年后慢性病的相关性研究 [Association between adverse experiences in childhood and risk of chronic diseases in adulthood]. *Chinese Journal of Epidemiology*, *36*(9), 953-957. [In Chinese]
- Okello, J., De Schryver, M., Musisi, S., Broekaert, E., & Derluyn, I. (2014). Differential roles of childhood adversities and stressful war experiences in the development of mental health symptoms in post-war adolescents in northern Uganda. *BMC Psychiatry*, *14*, 260.
- Parish, W. L., Wang, T., Laumann, E. O., Pan, S., & Luo, Y. (2004). Intimate partner violence in China: National prevalence, risk factors and associated health problems. *International Family Plan Perspectives*, *30*, 174-181.
- Platte, E. (1988). Divroce trends and patterns in China: Past and present. *Pacific Affairs*, *61*(3), 428-445.

- Prins, A., Ouimette, P., Kimerling, R., Cameron, R. P., Hugelshofer, D. S., Shaw-Hegwer, J., . . . & Sheikh, J. I. (2003). The primary care PTSD screen (PC-PTSD): Development and operating characteristics. *Primary Care Psychiatry, 9*(1), 9-14.
- Qualtrics (May 2018 of use) [Computer software]. Provo: UT. Available from <https://www.qualtrics.com>
- Ramiro, L. S., Madrid, B. J., & Brown, D. W. (2010). Adverse childhood experiences (ACE) and health-risk behaviors among adults in a developing country setting. *Child Abuse & Neglect, 34*(11), 842–855.
- Russell, D. (1980). The revised UCLA Loneliness Scale: Concurrent and discriminant validity evidence. *Journal of Personality and Social Psychology, 39*(3), 472-480.
- Russell, D., Peplau, L. A., & Cutrona, C. E. (1980). The Revised UCLA Loneliness Scale: Concurrent and discriminant validity evidence. *Journal of Personality and Social Psychology, 39*(3), 472-480.
- Slopen, N., Williams, D. R., Seedat, S., Moomal, H., Herman, A., & Stein, D. J. (2010). Adversities in childhood and adult psychopathology in the South Africa Stress and Health Study: Associations and first-onset DSM-IV disorders. *Social Science and Medicine, 71*(10), 1847-1854.
- Spitzer, R. L., & Kroenke, K., Williams, J., & Lowe, B. (2006). A brief measure for assessing generalized anxiety disorder. *Archives of Internal Medicine, 166*, 1092-1097.
- Stillman, S., Gibson, J. K., McKenzie, D. J., Rohorua, H. (2012). Miserable migrants? Natural experiment evidence on international migration and objective well-being, IZA Discussion Papers, No.6871, Institute for the Study of Labor (IZA), Bonn.
- Subramaniam, M., Chong, S. A., Satghare, P., Browning, C., & Thomas, S. (2017). Gambling and family: A two-way relationship. *Journal of Behavioral Addictions, 6*(4), 689-698.

- Suomi, A., Jackson, A. C., Dowling, N. A., Lavis, T., Patford, J., Thomas, S. A., Harvey, P., Abbott, M., Bellringer, M. E., Koziol-McLain, J., & Cockman, S. (2013). Problem gambling and family violence: Family member reports of prevalence, family impacts and family coping. *Asian Journal of Gambling Issues and Public Health*, 3(1), 13.
- Swopes, R. M., Simonet, D. V., Jaffe, A. E., Tett, R. P., & Davis, J. L. (2013). Adverse childhood experiences, posttraumatic stress disorder symptoms, and emotional intelligence in partner aggression. *Violence and Victims*, 28(3). Doi: 10.1891/0886-6708.VV-D-12-00026
- Tang, C. S., & Lai, B. P. (2008). Review of empirical literature on the prevalence and risk markers of male-on-female intimate partner violence in Contemporary China, 1987-2006. *Aggression and Violent Behavior*, 13, 10-28.
- Thompson, R., Litrownik, A. J., Isbell, P., Everson, M. D., English, D. J., Dubowitz, H., Flaherty, E. G. (2012). Adverse experiences and suicidal ideation in adolescence: Exploring the link using the LONGSCAN samples. *Psychology of Violence*, 2(2), 211–225.
- Tong, X., An, D., McGonigal, A., Park, S., & Zhou, D. (2015). Validation of the Generalized Anxiety Disorder-7 (GAD-7) among Chinese people with epilepsy. *Epilepsy Research*, 120, 31-36.
- Topitzes, J., Pate, D. J., Berman, N. D., & Medina-Kirchner, C. (2016). Adverse childhood experiences, health, and employment: A study of men seeking job services. *Child Abuse & Neglect*, 61, 23-34.
- Veugelers, R. (2017). China is the world's new science and technology powerhouse. Retrieved from <http://bruegel.org/2017/08/china-is-the-worlds-new-science-and-technology-powerhouse/>

- Wang, W., Bian, Q., Zhao, Y., Li, X., Wang, W., Du, J., Zhang, G., Zhou, Q., & Zhou, M. (2014). Reliability and validity of the Chinese version of the Patient Health Questionnaire (PHQ-9) in the general population. *General Hospital Psychiatry, 36*, 539-544.
- Wong, A. E., Dirghangi, S. R., & Hart, S. R. (2019). Self-concept clarity mediates the effects of adverse childhood experiences on adult suicide behavior, depression, loneliness, perceived stress, and life distress. *Self and Identity, 18*(3), 247-266.
- Wu, A. M. S., & Lau, J. T. F. (2015). Gambling in China: Socio-historical evolution and current challenges. *Addiction, 110* (2), 210-216.
- Xiao, Q., Dong, M., Yao, J., Li, W., & Ye, D. (2008). Parental alcoholism, adverse childhood experiences, and later risk of personal alcohol abuse among Chinese medical students. *Biomedical and Environmental Sciences, 21*, 411-419.
- Xing, X., Tao, F., Wan, Y., Xing, C., Qi, X., Hao, J., Su, P., Pan, H., & Huang, L. (2010). Family factors associated with suicide attempts among Chinese adolescent students: A national cross-sectional Survey. *Journal of Adolescent Health, 46*, 592-599.
- Xu, Y., Bright, C. L., & Ahn, H. (2018). Responding to child maltreatment: Comparison between the USA and China. *International Journal of Social Welfare, 27*(2), 107-120.
- Yue, A., Li, S., Shi, M., Shi, Y., Luo, R., Kenny, K., & Rozelle, S. (2016). Parental behavior and social-emotional development among infants in rural Shaanxi Province, China. Retrieved from <https://reap.fsi.stanford.edu/publication/parental-behavior-and-social-emotional-development-among-infants-rural-shaanxi-province>
- Zhang, Y., Liang, W., Chen, Z., Zhang, H., Zhang, J., Weng, X., Yang, S., Zhang, L., Shen, L., & Zhang, Y. (2013). Validity and reliability of Patient Health Questionnaire-9 and Patient Health Questionnaire-2 to screen for depression among college students in China. *Asia-Pacific Psychiatry, 5*, 268-275.

Zhao, Y., & Peng, Y. 乡村赌博的危害性及治疗的新路径 [The harm of gambling in rural areas and new paths for intervention]. *Legal System and Society*, 23, 203-204. [In Chinese]

Table 6
Description of Study Measures (N = 1,019)

Variable	% or mean (SD)
Age (range 18-21)	18.6 (0.8)
Gender (Male)	53.0
Father education (range 1-6)	3.1 (1.5)
Mother education (range 1-6)	2.5 (1.5)
Father unemployed	12.0
Mother unemployed	26.9
Parent was a migrant worker	71.3
Number of siblings (range 0-4)	1.0 (0.9)
<i>Social Economic Status Ladder</i> (range 1-10)	4.1 (1.4)
First ladder	1.2
Second ladder	9.1
Third ladder	29.0
Fourth ladder	25.2
Fifth ladder	22.2
Sixth ladder or above	13.1
<i>Mental Health Outcomes</i>	
Anxiety (range 0-21)	5.6 (4.2)
Depression (range 0-27)	5.9 (4.8)
Perceived stress (range 0-16)	6.1 (2.7)
Loneliness (range 0-8)	3.3 (2.1)
Posttraumatic stress (positive)	21.6
Suicide ideation (yes)	14.2

Table 7
Prevalence of ACEs among Chinese Young Adults (N = 1,019)

Measure	% or mean (SD)
<i>Conventional ACEs</i>	
Emotional abuse	6.0
Physical abuse	52.3
Sexual abuse	10.6
Physical neglect	4.7
Emotional neglect	8.2
Domestic violence	43.2
Household mental problem	8.5
Household substance abuse	13.0
Household crime	8.5
Parental divorce or separation	8.0
Cumulative score (range 0- 10)	1.6 (1.5)
0 ACEs	25.0
1 ACE	29.1
2 ACEs	21.5
3 ACEs	13.2
4 or more ACEs	11.2
<i>Other Potential Adversities</i>	
Family financial hardship	8.0
Food insecurity	3.2
Parental gambling problem	19.7
Peer victimization	3.5
Parental absence	37.4
Death of parent or sibling	14.3
Violent crime victimization	9.5

Table 8
Multivariate Model Results

Outcome	No of Typical 10 ACEs	B or OR (95% CI)
Anxiety	0	1.00 (referent)
	1	.92* (.194 - 1.64)
	2	.85* (.07 - 1.64)
	3	2.11*** (1.19 - 3.03)
	≥4	2.74*** (1.77 - 3.70)
Depression	0	1.00 (referent)
	1	.92* (.11 - 1.73)
	2	1.23* (.35 - 2.11)
	3	2.82*** (1.78 - 3.85)
	≥4	4.29*** (3.21 - 5.36)
Perceived stress	0	1.00 (referent)
	1	.62* (.18 - 1.06)
	2	.54* (.06 - 1.02)
	3	1.48*** (.93 - 2.04)
	≥4	2.24*** (1.66 - 2.82)
Loneliness	0	1.00 (referent)
	1	.41* (.05 - 0.76)
	2	.81*** (.43 - 1.20)
	3	1.16*** (.71 - 1.61)
	≥4	1.71*** (1.24 - 2.17)
Posttraumatic stress	0	1.00 (referent)
	1	1.42 (.87-2.33)
	2	1.71* (1.02-2.87)
	3	4.07*** (2.38-6.96)
	≥4	4.32*** (2.51-7.45)
Suicide ideation	0	1.00 (referent)
	1	3.74*** (1.80 - 7.74)
	2	4.25*** (2.00 - 9.05)
	3	5.97*** (2.72 - 13.10)
	4	15.46*** (7.27 - 32.89)

*p < .05, **p < 0.01, ***p < 0.001

CHAPTER 4

Intergenerational Effects of Maternal Adversity on Child Socio-Emotional Development

Abstract

This study examined how mothers' adverse childhood experiences (ACEs) relate to their offspring's socio-emotional outcomes, and how the association is mediated through mothers' adult adversity and mental health problems. The study sample includes 498 mothers with children aged 12-36 months who participated in the Families and Children Thriving (FACT) Study, a longitudinal investigation into the health and well-being of at-risk families in Wisconsin who received home visiting services. In addition to demographic information, survey data were collected on mothers' childhood and adult adversity, depression, anxiety, and posttraumatic stress. Children's socio-emotional development was measured via maternal responses to the Brief Infant Toddler Social Emotional Assessment. Multiple regression models were performed to assess associations between mothers' ACEs' scores and their children's socio-emotional development. Path analysis was also applied to assess whether mothers' mental health problems and adult adversity mediated the association between maternal ACEs and children's socio-emotional outcomes. Results indicated that around 83% of mothers reported at least 1 ACE, and over 84% reported one or more adult adversity. Maternal ACEs were significantly related to children's socio-emotional problems (OR = 1.12; 95% CI = 1.03, 1.21), but not with socio-emotional competence (OR = 0.99; 95% CI = .90, 1.10). Path analysis confirmed that maternal ACEs were associated with children's socio-emotional problems indirectly via maternal mental health problems and adult adversity. Implications of the study findings for prevention, intervention, and future research were also discussed.

Keywords: Adverse childhood experiences, adult adversity, child socio-emotional development, intergenerational study

Adverse childhood experiences (ACEs) such as child maltreatment and family dysfunction often have significant and lasting consequences. A large body of literature has documented an association between greater exposure to ACEs and an increased risk of a physical, mental and social problems over the life course (Hughes et al., 2017). It has been hypothesized that the negative impact of ACEs also may be transmitted across generations. That is, compared to adults who experienced normative levels of adversity in childhood, adults who experienced significant childhood adversity may be more likely to have offspring whose development is compromised. For example, recent studies have revealed that children whose parents endured childhood adversities such as emotional abuse and neglect are at risk of being maltreated and experiencing negative health outcomes (Dahlen, 2016; Hughes & Cossar, 2016; Plant, Barker, Waters, Pawlby, Pariante, 2013; Valentino, Nuttall, Comas, Borkowski, Akai, 2012). Still, research on the intergenerational impact of ACEs remains underdeveloped, and the mechanisms through which parents' ACEs impact their children's health outcomes are largely unknown.

In the last few years, scholars have begun to fill in these gaps in the literature. For example, Christiaens and colleagues conducted a case-control study 223 Canadian women, of which 75 were mothers with a spontaneous singleton preterm birth and 148 were mothers with an uncomplicated singleton birth and no history of preterm birth. They found that there was a significant association between ACEs and spontaneous preterm birth, which was the leading cause of infant mortality and morbidity. Adjusted for maternal age, smoking, educational status, and history of miscarriage, each additional ACE increased the risk of spontaneous preterm birth by 18% (Christiaens, Hegadoren, & Olson, 2015).

Another study of an at-risk sample of 398 pregnant women who were recruited from health clinics assessed the association between maternal ACE exposure and infant socio-emotional functioning (McDonnell & Valentino, 2016). Results showed that mothers who

were child maltreatment victims were more likely to have infants with maladaptive socio-emotional symptoms at six months of age. In addition, mothers' exposure to household dysfunction in childhood indirectly predicted infant socio-emotional functioning through maternal age at first pregnancy and infant birth weight. A third study of 350 parent-child dyads in Philadelphia, Pennsylvania found that a greater number of parent ACEs was associated with a greater likelihood of poor child health, asthma, and excessive television watching (Lê-Scherban, Wang, Boyle-Steed, Lee, & Pachter, 2018). Last, a study conducted by Folger and colleagues (2018) retrospectively examined 311 mother-child and 122 father-child dyads who attended a large pediatric primary care practice. They discovered that parental ACEs were associated with an increased risk of child developmental delays, including problem solving, communication, person-social, and motor skills at age two.

Extending research on the direct relationship between parental ACEs and child outcomes, researchers have also tested potential mechanisms through which parental ACEs may impact the next generation's health and development. For instance, in a study of 1,293 parent-child dyads who were recruited from the emergency department of a children's hospital, Sun et al. (2017) found that mothers with greater exposure to ACEs were more likely to have children with early developmental problems, including social-emotional and behavioral difficulties. They also found that mothers' depressive symptoms and self-rated health mediated the association between mothers' ACEs and children's developmental risks. A recent analysis of data from the Panel Study of Income Dynamics also revealed that parents' ACEs increased their children's risk of behavioral problems, and the relationship was mediated by parent emotional distress and aggravation with parenting (Schickedanz, Halfon, Sastry, & Chung, 2018).

The emerging body of intergenerational ACE research holds the promise of deepening our understanding of risk transmission. This knowledge may ultimately inform both universal

prevention strategies and more targeted intervention services and programs that aim to interrupt these intergenerational cycles. Replication research along these lines is needed, particularly with diverse populations. In addition, other potential pathways need to be explored to expand our knowledge about the mechanisms of risk transmission.

Using data from a sample of low-income families in Wisconsin, this study aims to examine associations between maternal ACE exposure and young children's socioemotional development. In addition to main-effect analyses, this study assesses two mechanisms that may contribute to the intergenerational transmission of effect. The first hypothesized mechanism is *parental mental health*. This hypothesis posits that parents' exposure to ACEs increases their mental health problems such as depression, anxiety, and posttraumatic stress (e.g., Kalmakis & Chandler, 2015; Merrick et al., 2017), which, in turn, increase their children's risk of socio-emotional disturbances (e.g., Goodman et al., 2011; Treyvaud et al., 2010; Van den Bergh & Marcoen, 2004). The second mechanism is *adult adversity*. The hypothesis is that parents' exposure to childhood adversity increases their risk of adult adversities such as domestic violence, homelessness, and poverty (Roos et al., 2013; Whitfield, Anda, Dube, & Felitti., 2003; Zielinski, 2009). Children's social-emotional development may be impacted directly by these adversities when they occur in a shared environment (e.g., Bethell, Newacheck, Hawes, & Halfon, 2014; Burke, Hellman, Scott, Weems, & Carrion, 2011; Freeman, 2014; Hunt, Slack, Berger, 2017). Children also may be impacted indirectly by their parents' adversity, as it may compromise their caregiving and their capacity to provide their children with an average expected environment (Cicchetti & Valentino, 2006). In sum, this study examines two main research questions:

1. Is there an association between the number of ACEs a mother endured and her child's risk of socio-emotional problems?
2. Do mothers' self-reported mental health problems and cumulative adult adversity mediate

the association between mothers' ACE scores and their children's socio-emotional problems?

Methods

Research Design

This study used data from the Families and Children Thriving (FACT) Study, a longitudinal investigation into the health and well-being of at-risk children and families in Wisconsin since July 2015. Mothers of young children were recruited from Wisconsin's Family Foundations Home Visiting (FFHV) program, which is a statewide network of agencies that provide evidence-based home visiting services beginning prenatally and lasting up to a child's 2nd or 3rd birthday. All English- and Spanish-speaking primary caregivers that received services from a FFHV-supported program were eligible. Recruitment activities were initiated with potential participants at least 30 days after the birth of an index child associated with a home visiting service episode (For more research design details, please refer to Mersky, Janczewski, & Nitkowski, 2018).

Data and Sample

Survey data were drawn from Wave I and Wave II of the FACT Study. Mothers participating in home visiting services are asked to complete the Wave I survey as early as 30 days postpartum. Wave II survey data are collected approximately one year later. For the present study, Wave I data are used to measure household demographics as well as maternal mental health and adult adversities. Wave II supplies data regarding the index child's development. Approximately 98% of the participant households are at or below 200% of the federal poverty threshold or are eligible for federal means-tested benefits such as the Supplemental Nutrition Assistance Program.

The study sample consists of 498 mother-child dyads who met four inclusion criteria. First, all mothers must have completed both Wave I and Wave II surveys. Second, because adult adversity is one of the study's hypothesized mediators, all mothers had to be at least 19

years old at Wave I so they could have experienced adult adversity for at least one year.

Third, mothers had to have matching ACE data that were assessed by home visiting staff and recorded in a state public health database. Fourth, at Wave II the mother's focal child must have been between 12 and 36 months old, the validated age range for the Brief Infant-Toddler Social and Emotional Assessment (BITSEA).

Measures

Adverse Childhood Experiences.

ACEs were measured using the Childhood Experiences Survey (CES; Mersky, Janczewski, & Topitzes, 2017), which includes 10 conventional ACEs (e.g., physical abuse; sexual abuse; parental mental illness) and seven other potentially significant adversities, including family financial hardship, food insecurity, homelessness, parental absence, death of parent or sibling, violent crime victimization, and peer victimization. The CES has demonstrated solid internal consistency, test-retest reliability, and predictive validity (Mersky et al., 2017). Replicating measurement conventions in the literature, each of the 10 conventional ACEs was dichotomized and summed to produce an aggregate score (range 0-10).

Child Socioemotional Functioning.

Child socioemotional functioning was measured by the Brief Infant Toddler Social Emotional Assessment (BITSEA; Briggs-Gowan, Carter, Irwin, Watchtel, & Cicchetti, 2004), a 42-item screener for social-emotional difficulties in children ages 12 to 36 months. The BITSEA Parent Form yields two broadband scales: (1) Social Emotional Problem and (2) Social Emotional Competence. The Problem scale includes 31 items that assess externalizing problems (e.g. aggression and defiance), internalizing problems (e.g. anxiety and depression), and problems of dysregulation (e.g. eating and sleeping problems). The Competence scale includes 11 items on social-emotional abilities such as sustained attention

and compliance. Higher Problem scores indicate greater levels of social-emotional or behavioral problems, while lower Competence scores indicate a possible deficit/delay in social emotional competence. The measure also has Problem cut scores and Competence cut scores based on different age groups (12 to 17 months, 18 to 23 months, 24 to 29 months, and 30 to 35 months 30 days) by sex. The BITSEA has been shown to have good test-retest reliability, interrater agreement, and supporting validity (Briggs-Gowan et al., 2004). In this sample, internal consistency reliabilities were 0.84 for the Problem scale and 0.66 for the Competence scale.

Maternal Mental Health Problems.

Maternal mental health problems were measured in three different domains: depression, anxiety and posttraumatic stress. Depression was measured by the Patient Health Questionnaire (PHQ-9), which is a 9-item instrument for screening, diagnosing, monitoring and measuring the severity of depression in primary care settings (Kroenke, Spitzer, & Williams, 2001). Research has shown that the PHQ-9 has sound internal reliability ($\alpha = 0.89$) and diagnostic validity (Huang, Chung, Kroenke, Delucchi, & Spitzer, 2006; Kroenke et al., 2001). The internal reliability of PHQ-9 for the current sample was 0.89.

Anxiety was assessed by the Generalized Anxiety Disorder 7-item (GAD-7) scale, which is a brief measure for assessing generalized anxiety disorder (Spitzer, & Kroenke, Williams, & Lowe, 2006). Research has shown that the GAD-7 scale also has sound internal consistency ($\alpha = 0.92$), test-retest reliability ($r = 0.83$), and convergent validity (Spitzer et al., 2006). For this sample, the internal consistency of the GAD-7 was 0.90.

Posttraumatic stress was measured using the 4-item Primary Care PTSD Screen (PC-PTSD). This scale also has been shown to have sound psychometric properties, including good test-retest reliability (i.e., $r = 0.83$; Prins et al., 2003). If participant answered “yes” to any three items, the result of the PC-PTSD was considered “positive” for probable PTSD.

Adult Adversity.

Adult adversity was measured using the Adult Experiences Survey (Mersky et al., 2018). Ten potential adult adversities were assessed, including five that reference a current or former partner or spouse: physical abuse, emotional abuse, alcohol misuse or drug use, mental health problem, and incarceration or jail. Five other adversities that were assessed include forced sexual activity (partner/spouse or other perpetrator), crime victimization, homelessness, chronic financial problems, and discrimination. The 10 indicators of adult adversity were dichotomized and summed to create a cumulative risk score (range 0–10).

Covariates.

Significant demographic variables were included as covariates in multivariate analyses. Maternal age and child age were coded as continuous variables. Maternal race/ethnicity was coded as five distinct groups: White, Black, Hispanic, American Indian and Other. Maternal education was coded as an ordinal variable ranging from less than high school (1) to completion of a four-year college or higher (6). Maternal employment (full-time or part-time) was coded as a dichotomous variable which indicates whether or not mothers were employed. Last, maternal cohabitation was coded as a dichotomous variable that denotes if mothers were currently living with a spouse or partner.

Data Analysis

Descriptive analyses were performed with SPSS (version 23), rendering percentages, means, and standard deviations for all study variables. Multiple regression models were also performed by SPSS to assess associations between mothers' ACEs' scores and their children's socioemotional development. Path analysis using Mplus (version 8) was applied to assess whether mothers' mental health problems and adult adversity mediate the association between maternal ACEs and children's socioemotional outcomes (see Fig. 1). Bootstrapped standard errors and confidence intervals were used to assess the indirect effects (Preacher &

Hayes, 2004). For the path analysis, a latent mental health variable was created from the three mental health variables: depression, anxiety, and posttraumatic stress, because they were highly correlated (see Table 2). Scores of the three mental health variables were also standardized respectively. All analyses controlled for covariates described above.

Results

Results of descriptive analyses are presented in Table 9. The mean age of participant mothers was 27.6 ($SD = 5.8$). An analysis of race/ethnicity showed that 40.4% were White, 21.1% were Black, 27.3% were Hispanic, 5.8% were American Indian, and 5.4% were other race/ethnicity. The mean education level of mothers was 3.4 ($SD = 1.1$) on a scale of 1-6. Results (not shown) indicated that 55.6% had completed high school or obtained a general equivalency diploma. 42.8% of mothers reported that they were full-time or part-time employed. The majority of women were cohabitating with a partner or spouse (57.2%). The average age of children was nearly 20 months, and 52.2% of children were female.

The mean number of ACEs reported by mothers was 3.3 ($SD = 2.6$). About 83% of the sample reported at least 1 ACE exposure in their childhood, and nearly 43% reported 4 or more ACEs. The most prevalent ACEs were parental substance use (49.9%), mental illness (43.7%), and physical abuse (43.3%). The mean number of adult adversities was 3.9 ($SD = 2.9$); 84.3% of mothers reported at least 1 adult adversity, and 51.4% reported 4 or more adult adversities. The most prevalent adult adversities were emotional abuse by a spouse or partner (58.1%), discrimination (54.2%), and incarceration or jail by spouse or partner (46.2%).

Mothers' mean score on depression was 5.4 ($SD = 5.7$), and 19.6% met the screening criteria for potential depression. Mothers' mean score on anxiety was 5.3 ($SD = 5.4$), and 18.9% met the criteria for potential anxiety. Mothers' mean score on the PTSD screen was 1.0, and 19.5% met the criteria for positive PTSD. For children's BITSEA results, the mean score on Problem scale was 10.7 ($SD = 7.3$), and 29.5% of children met the screening criteria

for social emotional problems. The mean score on the Competence scale was 17.0 ($SD = 3.2$), and 15.8% of children met the screening criteria for social emotional competence delay.

(Table 9 Inserted Here)

Table 10 shows the correlations among independent variable, dependent variables, and mediators in this study. Results indicated that there were significant bivariate relationships among ACEs, adult adversity, mental health problems, and children's problem total scores. Children's Competence scale scores were significantly associated with their Problem scale scores but not with other study measures.

(Table 10 Inserted Here)

Table 11 presents the results from the logistic regression analysis. Black race ($OR = 1.94$; 95% $CI = 1.12, 3.37$) and maternal ACE scores ($OR = 1.12$; 95% $CI = 1.03, 1.21$) were both positively associated with children's problem scores while mother's age ($OR = 0.96$; 95% $CI = 0.92, 0.99$) and education level ($OR = .80$; 95% $CI = 0.65, 0.99$) were negatively associated with children's problem scores. Only child age ($OR = 1.05$; 95% $CI = 1.01, 1.10$) was significantly associated with children's competence scores.

(Table 11 Inserted Here)

Figure 2 reveals the results of path analysis between maternal ACEs and child problem total score. Fit statistics indicated that the model fit the data well ($\chi^2 = 105.6$, $p < 0.001$; $RMSEA = 0.06$ (90% $CI = 0.04, 0.07$); $CFI = 0.95$; $SRMR = 0.04$). The effects of maternal ACEs on both maternal adult adversity ($\beta = 0.50$, 95% $CI = 0.43, 0.56$) and mental health ($\beta = 0.18$, 95% $CI = 0.07, 0.20$) were significant. Adult adversity also forged a significant association with maternal mental health ($\beta = 0.58$, 95% $CI = 0.48, 0.67$), and maternal mental health was significantly associated with child problem scores ($\beta = 0.41$, 95% $CI = 0.25, 0.58$). The adult adversity index was not directly associated with child problem scores, however ($\beta = -0.09$, 95% $CI = -0.25, 0.06$).

The hypothesis that maternal ACEs had direct association with child problem scores was not supported ($\beta = -0.01$, 95% *CI* = -0.12, 0.09), but the total indirect effect of ACEs on child problem via adult adversity and mental health was significant ($\beta = 0.15$, 95% *CI* = 0.08, 0.23). In sum, maternal ACE scores did not have a direct association with child socio-emotional problems. Their effects, instead, appeared to manifest indirectly via adult adversity and mental health.

(Figure 2 Inserted Here)

Discussion

This study joins an emerging body of literature that aims to uncover the mechanisms through which parents' adversity and trauma might impact the health outcomes of their offspring. Descriptive statistics from the current investigation indicate that women of low socioeconomic status were at higher risk for childhood adversity, adult adversity, and mental health problems. For example, 82.9% of women were exposed to at least 1 ACE, and 84.3% of women were exposed to at least 1 adult adversity. The prevalence of ACEs in this sample is higher than prior national estimates in the U.S. (Green, et al., 2010; Merrick, Ford, Ports, & Guinn, 2018). The sample also reported high rates of adverse adult experiences. For instance, the rates of domestic violence (58.1% emotional abuse; 45.9% physical abuse; 19.7% sexual abuse) reported in this study exceeds the estimated prevalence in the U.S. population. According to the study of Breiding et al. (2014), within the context of an intimate partner relationship, nearly 50% of U.S. women experienced emotional abuse, 25% experienced physical abuse, and approximately 10% experience sexual abuse. The rest of adverse adult experiences measured were also prevalent in this economically disadvantaged sample of women.

Considering the high rates of adversity that the study participants endured, it is unsurprising that they frequently reported mental health difficulties. For instance, 19.5% of

women in the current study met the screening criteria for posttraumatic stress, 19.6% met the criteria for depression, and 18.9% met the criteria for anxiety. Also, about 35% of women (not shown in table) had experienced at least one of the three mental health problems. This number is higher than that of the national mental illness report which revealed that approximately 1 in 5 adults in the U.S. experienced mental illness in a given year (National Institute of Mental Health, 2017).

This study confirmed that childhood adversity, adult adversity, adult mental health problems, and child socio-emotional problems were significantly inter-correlated. A multivariate analysis also showed that higher maternal ACE scores were significantly associated with increased child socio-emotional problems, though the magnitude of association was small. This finding is consistent with prior research, which has shown that maternal ACEs are significantly associated with child outcomes, though the magnitude of effect tends to be small (Lê-Scherban et al., 2018). In addition, children's social-emotional competence ratings were not significantly associated with maternal ACE scores. One possible explanation for this result is that the competence scale may not be a sound measure of child social-emotional functioning in the present sample. The internal consistency reliability of the scale ($\alpha = 0.66$) was in the low-to-moderate range, and it was not correlated with various indicators of risk and adversity, raising questions about its convergent validity. Assessing young children accurately is inherently difficult because their development is relatively undifferentiated and changing at a rapid rate (Konold, Hamre, & Pianta, 2003). Further research is needed to determine whether the BITSEA, and more specifically the competence subscale, is a reliable and valid measure in diverse samples.

Findings from the path analysis revealed that the association between maternal ACEs and children's social-emotional problems were mediated by maternal adult adversity and mental health problems. Specifically, the results suggested that mothers who were exposed to

childhood adversity were more likely to have mental health disturbances in adulthood, increasing their children's risk of social-emotional problems. Also, results suggested that mothers who experienced more adversity in childhood also experienced more adult adversity. Although adult adversity didn't have direct impact on child social emotional problems, it affected maternal mental health directly, then impacted children's social-emotional functioning indirectly.

This path analysis finding is consistent with a prior study, which confirmed the relationship between maternal ACEs, adult adversity and mental health problems (Mersky et al., 2018). Additionally, a large body of research has shown that witnessing adult adversity, like domestic violence is harmful to children (Kitzmann, Gaylord, Holt, & Kenny, 2003). Even if they do not witness the domestic violence or other adversities, children can still be impacted indirectly if their mothers experience adversity. The current study and many other studies have confirmed this: adult adversity can undermine parents' mental health (e.g., Geller & Franklin, 2014; Mersky et al., 2018; Walker & Druss, 2017; Walker, Liddle, Jordan, & Campbell, 2017), and parents' poor mental health may compromise their' ability to protect and nurture their children (Goodman et al., 2011; Treyvaud et al., 2010; Van den Bergh & Marcoen, 2004).

Limitations

The study findings should be interpreted in light of the following limitations. First, sample participants were women from predominantly lower socioeconomic backgrounds, and as a result, the findings may not be generalizable to other populations. Second, this study relied mainly on self-report data. It is possible that, due to social desirability, mothers may have underreported their adversity as well as their children's social-emotional challenges. Third, this study used cumulative scores for childhood adversity and adult adversity, which means each adversity was weighted equally. Although cumulative risk scores have

advantages, including strong predictive validity and replicability, they do not differentiate the severity, timing, and duration of each adversity (Mersky et al., 2018). Lastly, research has confirmed that protective factors, particularly the stable relationships with caring and supportive adults, can buffer the detrimental effects of adversity (National Scientific Council on the Developing Child, 2015). However, this study only highlighted the negative impacts of adversity, but omitted the positive effects of protective factors which may counterbalance the effects of adversity.

Implications and Future Directions

Corroborating previous findings (Christiaens et al., 2015; Folger et al., 2018; Lê-Scherban et al., 2018; McDonnell & Valentino, 2016), this study confirmed that a child's social-emotional outcomes can be partly explained, not only by their own environmental experiences, but also by environmental influences that preceded their conception and birth. This study also demonstrated that the route from maternal ACEs to child social-emotional problems was indirect. Child problems emerged via two pathways: adult adversity and mental health problems.

The findings have significant practical implications. First, the study results underscore the need for early intervention and support for women who have been endured significant childhood adversity. It also highlights the need for approaches that can prevent these women from experiencing domestic violence and other adult adversities. As implemented among the current sample, two-generation home visiting programs, for instance, may have the potential to mitigate the effects of adversity for mothers and reduce the likelihood that their children will be exposed to similar adversities. In this regard, home visiting can simultaneously operate as an intervention and a primary prevention strategy. By interrupting the intergenerational transmission of trauma, home visiting programs represent an important public health strategy for promoting the health and well-being of vulnerable mothers and

children.

Second, the research findings indicate that maternal mental health problems which directly impact children's social emotional problems, were prevalent among this economically disadvantaged group. Therefore, there is great need for targeted intervention strategies that can address maternal mental health problems and children's social emotional problems. Again, Two-generation models such as home visiting services may be particularly promising because they can simultaneously address caregiver mental health problems, enhance parenting practices as well as promote child development.

Future research should examine whether different types, severity, timing and chronicity of exposure to childhood adversity and adulthood adversity play a role in the transmission from mothers' trauma to their offspring. To ensure the accuracy of child outcomes measure, future studies may also consider including other types of measure of child socio-emotional outcomes, such as observation, daycare teacher report, rather than only rely on mother's self-report. Moreover, protective factors such as intimate relationship and social support that may buffer against the effect of childhood adversity and promote resilience should also be considered in future adversity studies. Additionally, this study only focused on psychosocial mechanisms. However, several other studies have revealed that maternal ACEs might also transmitted effect through biological mechanisms (Madigan, Wade, Plamondon, Maguire, & Jenkins, 2017; Racine, Plamondon, Madigan, McDonald, & Tough, 2018). Future research may need to measure genetic, biological, psychological, and social pathways all together, to provide a full picture for the intergenerational transmission of ACEs. Finally, further research is needed that examines prevention and intervention approaches that have the potential to interrupt the intergenerational transmission of trauma.

References

- Bethell, C. D., Newacheck, P., Hawes, E., & Halfon, N. (2014). Adverse childhood experiences: assessing the impact on health and school engagement and the mitigating role of resilience. *Health Affairs, 33*(12), 2106-2115.
- Breiding, M. J., Chen, J., & Black, M. C. (2014). Intimate Partner Violence in the United States -2010. National Center for Injury Prevention and Control, Centers for Disease Control and Prevention, Atlanta, GA.
- Briggs-Gowan, M. J., Carter, A. S., Irwin, J. R., Watchtel, K., & Cicchetti, D. V. (2004). The Brief Infant-Toddler Social Emotional Assessment: Screening for social-emotional problems and delays in competence. *Journal of Pediatric Psychology, 29*(2), 143-155.
- Burke, N. J., Hellman, J. L., Scott, B. G., Weems, C. F., & Carrion, V. G. (2011). The impact of adverse childhood experiences on an urban pediatric population. *Child Abuse & Neglect, 35*, 408-413.
- Christiaens, I., Hegadoren, K., & Olson, D. M. (2015). Adverse childhood experiences are associated with spontaneous preterm birth: A case-control study. *BMC Medicine, 13*(1), 124.
- Cicchetti, D., & Valentino, K. (2006). An ecological-transactional perspective on child maltreatment: Failure of the average expectable environment and its influence on child development. In D. Cicchetti & D. J. Cohen (Eds.), *Developmental psychopathology* (2nd ed., pp. 129–201). Hoboken, NJ: Wiley.
- Dahlen, H. M. (2016). The impact of maternal depression on child academic and socioemotional outcomes. *Economics of Education Review, 52*, 77-90.
- Folger, A. T., Eismann, E. A., Stephenson, N. B., Shapiro, R. A., Macaluso, M., Brownrigg, M. E., & Gillespie, R. J. (2018). Parental adverse childhood experiences and offspring development at 2 years of age. *Pediatrics, 141*(4): e20172826.

- Freeman, P. (2014). Prevalence and relationship between adverse childhood experiences and child behavior among young children. *Infant Mental Health Journal, 35*(6), 544-554.
- Geller, A., & Franklin, A. W. (2014). Paternal incarceration and the housing security of urban mothers. *Journal of Marriage and Family, 76*(2), 411-427.
- Goodman, S. H., Rouse, M. H., Connell, A. M., Broth, M. R., Hall, C. M., & Heyward, D. (2011). Maternal depression and child psychopathology: A meta-analytic review. *Clinical Child and Family Psychology Review, 14*(1), 1-27.
- Green, J. G., McLaughlin, K. A., Berglund, P. A., Gruber, M. J., Sampson, N. A., Zaslavsky, A. M., & Kessler, R. C. (2010). Childhood adversities and adult psychiatric disorders in the national comorbidity survey replication I: associations with first onset of DSM-IV disorders. *Archives of General Psychiatry, 67*(2), 113-123.
- Huang, F. Y., Chung, H., Kroenke, K., Delucchi, K. L., & Spitzer, R. L. (2006). Using the patient health questionnaire-9 to measure depression among racially and ethnically diverse primary care patients. *Journal of General Internal Medicine, 21*(6), 547-552.
- Hughes, K., Bellis, M. A., Hardcastle, K. A., Sethi, D., Butchart, A., Mikton, C., Jones, L., & Dunne, M. P. (2017). The effect of multiple adverse childhood experiences on health: A systematic review and meta-analysis. *The Lancet Public Health, 2*(8), e356-e366.
- Hughes, M., & Cossar, J. (2016). The relationship between maternal childhood emotional abuse/neglect and parenting outcomes: A systematic review. *Child Abuse Review, 25*(1), 31-45.
- Hunt, T. K. A., Slack, K. S., & Berger, L. M. (2017). Adverse childhood experiences and behavioral problems in middle childhood. *Child Abuse & Neglect, 67*, 391-402.
- Kalmakis, K. A., & Chandler, G. E. (2015). Health consequences of adverse childhood experiences: A systematic review. *Journal of the American Association of Nurse Practitioners, 27*(8), 457-465.

- Kitzmann, K. M., Gaylord, N. K., Holt, A. R., & Kenny, E. D. (2003). Child witness to domestic violence: A meta-analytic review. *Journal of Consulting and Clinical Psychology, 71*(2), 339-352.
- Konold, T. R., Hamre, B. K., & Pianta, R. C. (2003). Measuring problem behaviors in young children. *Behavioral Disorders, 28*(2), 111-123.
- Kroenke, K., Spitzer, R., & Williams, W. (2001). The PHQ-9: Validity of a brief depression severity measure. *Journal of General Internal Medicine, 16*, 606-616.
- Lê-Scherban, F., Wang, X., Boyle-Steed, K. H., Lee, M., & Pachter, D. O. (2018). Intergenerational Associations of Parent Adverse Childhood Experiences and Child Health Outcomes. *Pediatrics, 141*(6): e20174274
- Madigan, S., Wade, M., Plamondon, A., Maguire, J. L., & Jenkins, J. M. (2017). Maternal adverse childhood experience and infant health: Biomedical and psychosocial risks as intermediary mechanisms. *The Journal of Pediatrics, 187*, 282-289.
- McDonnell, C. G., & Valentino, K. (2016). Intergenerational effects of childhood trauma: Evaluating pathways among maternal ACEs, perinatal depressive symptoms, and infant outcomes. *Child Maltreatment, 21*(4), 317-326.
- Merrick, M. T., Ford, D. C., Ports, K. A., & Guinn, A. S. (2018). Prevalence of Adverse Childhood Experiences From the 2011-2014 Behavioral Risk Factor Surveillance System in 23 States. *JAMA Pediatrics, 172*(11), 1038-1044.
- Merrick, M. T., Ports, K. A., Ford, D. C., Afifi, T. O., Gershoff, E. T., & Grogan-Kaylor, A. (2017). Unpacking the impact of adverse childhood experiences on adult mental health. *Child Abuse & Neglect, 69*, 10-19.
- Mersky, J. P., Janczewski, C. E., & Nitkowski, J. C. (2018). Poor mental health among low-income women in the U. S.: The roles of adverse childhood and adult experiences. *Social Science & Medicine, 206*, 14-21.

- Mersky, J. P., Janczewski, C. E., & Topitzes, J. (2017). Rethinking the measurement of adversity: Moving toward second-generation research on adverse childhood experiences. *Child Maltreatment, 22*(1), 58-68.
- National Institute of Mental Health. (2017). Prevalence of Any Mental Illness (AMI). Retrieved from https://www.nimh.nih.gov/health/statistics/mental-illness.shtml#part_154785
- National Scientific Council on the Developing Child. (2015). Supportive Relationships and Active Skill-Building Strengthen the Foundations of Resilience: Working Paper 13. Retrieved from <http://www.developingchild.harvard.edu>
- Plant, D. T., Barker, E. D., Waters, C. S., Pawlby, S., & Pariante, C. M. (2013). Intergenerational transmission of maltreatment and psychopathology: The role of antenatal depression. *Psychological Medicine, 43*(3), 519-528.
- Preacher, K. J., & Hayes, A. F. (2004). SPSS and SAS procedures for estimating indirect effects in simple mediation models. *Behavior Research Methods, 36*(4), 717-731.
- Prins, A., Ouimette, P., Kimerling, R., Cameron, R. P., Hugelshofer, D. S., Shaw-Hegwer, J., . . . & Sheikh, J. I. (2003). The primary care PTSD screen (PC-PTSD): Development and operating characteristics. *Primary Care Psychiatry, 9*(1), 9-14.
- Racine, N., Plamondon, A., Madigan, S., McDonald, S., & Tough, S. (2018). Maternal adverse childhood experiences and infant development. *Pediatrics, 141*(2): e20172495.
- Roos, L. E., Mota, N., Afifi, T. O., Katz, L. Y., Distasio, J., & Sareen, J. (2013). Relationship between adverse childhood experiences and homelessness and the impact of axis I and II disorders. *American Journal of Public Health, 103*(S2), S275-S281.
- Schickedanz, A., Halfon, N., Sastry, N., & Chung, P. J. (2018). Parents' adverse childhood experiences and their children's behavioral health problems. *Pediatrics, 142*(2): e20180023

- Spitzer, R. L., & Kroenke, K., Williams, J., & Lowe, B. (2006). A brief measure for assessing generalized anxiety disorder. *Archives of Internal Medicine*, *166*, 1092-1097.
- Sun, J., Patel, F., Rose-Jacobs, R., Frank, D. A., Black, M. M., & Chilton, M. (2017). Mothers' adverse childhood experiences and their young children's development. *American Journal of Preventive Medicine*, *53*(6), 882-891.
- Treyvaud, K., Anderson, V. A., Lee, K. J., Woodward, L. J., Newnham, C., Inder, T. E., Doyle, L. W., & Anderson, P. J. (2010). Parental mental health and early social-emotional development of children born very preterm. *Journal of Pediatric Psychology*, *35*(7), 768-777.
- Valentino, K., Nuttall, A. K., Comas, M., Borkowski, J. G., & Akai, C. E. (2012). Intergenerational continuity of child abuse among adolescent mothers: authoritarian parenting, community violence, and race. *Child Maltreatment*, *17*(2), 172-181.
- Van den Bergh, B. R. H., & Marcoen, A. (2004). High antenatal maternal anxiety is related to ADHD symptoms, externalizing problems, and anxiety in 8- and 9-year olds. *Child Development*, *75*, 1085-1097.
- Walker, E. R., & Druss, B. G. (2017). Cumulative burden of comorbid mental disorders, substance use disorders, chronic medical conditions, and poverty on health among adults in the USA. *Psychology, Health & Medicine*, *22*(6), 727-735.
- Walker, J., Liddle, J., Jordan, K. P., & Campbell, P. (2017). Affective concordance in couples: A cross-sectional analysis of depression and anxiety consultations within a population of 13,507 couples in primary care. *BMC Psychiatry*, *17*(1), 190.
- Whitfield, C., Anda, R., Dube, S., & Felitti, V. (2003). Violent childhood experiences and the risk of intimate partner violence in adults: assessment in a large health maintenance organization. *Journal of Interpersonal Violence*, *18*(2), 166-185.

World Health Organization. (2013). *Global and Regional Estimates of Violence against Women: Prevalence and Health Effects of Intimate Partner Violence and Non-Partner Sexual Violence*. WHO Press, Geneva.

Zielinski, D. S. (2009). Child maltreatment and adult socioeconomic well-being. *Child Abuse and Neglect*, 33(10), 666-678.

Table 9
Description of Study Variables (N = 498)

	% or Mean (SD) ^a
<i>Demographic Information</i>	
Maternal age (range 19-47 years)	27.6 (5.8)
Maternal education level (range 1-6)	3.4 (1.1)
Maternal race/ethnicity	
White	40.4%
Black	21.1%
Hispanic	27.3%
American Indian	5.8%
Other	5.4%
Maternal employment	42.8%
Maternal cohabitation with partner or spouse	57.2%
Child age (range 12-36 months)	19.4 (5.8)
Child sex (female)	52.2%
<i>Adverse Childhood Experiences (ACE)</i>	
Cumulative score (range 0-10)	3.3 (2.6)
0 ACE	17.1%
1 ACE	15.1%
2 ACEs	12.9%
3 ACEs	12.2%
4 or above ACEs	42.7%
Physical abuse	43.3%
Emotional abuse	27.1%
Sexual abuse	25.9%
Physical neglect	12.5%
Emotional neglect	16.9%
Domestic violence	39.6%
Substance use	49.9%
Mental illness	43.7%
Parental separation or divorce	40.0%
Household crime	34.2%
<i>Adverse Adult Experiences (AAE)</i>	
Cumulative score (range 0- 10)	3.9 (2.9)
0 AAE	15.7%
1 AAE	13.5%
2 AAEs	10.6%
3 AAEs	8.8%
4 or above AAEs	51.4%
Physical abuse, partner or spouse	45.9%
Emotional abuse, partner or spouse	58.1%
Alcohol misuse/drug use, partner or spouse	42.7%
Mental health problem, partner or spouse	32.3%
Incarceration/jail, partner or spouse	46.2%
Forced sexual activity	19.7%
Crime victimization	29.6%
Homelessness	34.3%

Financial problems (often or very often)	25.1%
Discrimination (sometimes, often or very often)	54.2%

Mental Health Problems

Depression scale (range 0-27)	5.4 (5.7)
Depression score ≥ 10	19.6%
Anxiety scale (range 0-21)	5.3 (5.4)
Anxiety score ≥ 10	18.9%
PTSD scale (range 0-4)	1.0 (1.4)
PTSD score ≥ 3	19.5%

Brief Infant-Toddler Social and Emotional Assessment

Problem total score (range 0-62)	10.7 (7.3)
Problem \geq cut-off score	29.5%
Competence total score (range 0-22)	17.0 (3.2)
Competence \leq cut-off score	15.8%

a Values for dichotomous measures are expressed as percentages (%). Mean and standard deviation (SD) values are presented for all other measures.

Table 10
Correlations between Childhood Adversity, Adulthood Adversity, Mother Mental Health Problems, and Child's Problem and Competence Outcomes

	1.	2.	3.	4.	5.	6.	7.
1. ACEs Index	-						
2. Adult Adversity Index	.50**	-					
3. Depression Total Score	.34**	.51**	-				
4. Anxiety Total Score	.33**	.50**	.84**	-			
5. PTSD Total Score	.36**	.47**	.54**	.53**	-		
6. Problem Total Score	.12**	.11*	.25**	.26**	.20**	-	
7. Competence Total Score	.04	.04	-.06	-.06	.03	-.27**	-

Note. Asterisks indicate statistical significance. * $P < .05$; ** $P < .01$.

Table 11
Regression Analysis of the Effects of Maternal Childhood Adversity on Child's Problem and Competence Outcomes

	Problem cutoff	Competence cutoff
	OR (95% CI)	OR (95% CI)
Mother age	.96* (.92 - .99)	1.01 (.97 - 1.05)
Race/ethnicity		
Hispanic	1.05 (.60 - 1.83)	.68 (.35 - 1.32)
Black	1.94* (1.12 - 3.37)	.84 (.41 - 1.71)
American Indian	1.52 (.65 - 3.60)	.58 (.16 - 2.06)
Other	1.45 (.57 - 3.65)	.77 (.24 - 2.46)
Education level	.80* (.65 - 0.99)	.88 (.68 - 1.14)
Employment status	.85 (.55 - 1.30)	.60 (.35 - 1.04)
Cohabitation status	.90 (.58 - 1.38)	1.29 (.75 - 2.23)
Child age	1.00 (.968 - 1.04)	1.05* (1.01 - 1.10)
ACEs index	1.12** (1.03 - 1.21)	.99 (.90 - 1.10)

* $p \leq 0.05$, ** $P \leq 0.01$.

Figure 2
Mediation Analysis Model Linking Maternal ACEs to Child Problem through Maternal Adult Adversity and Mental Health Problems

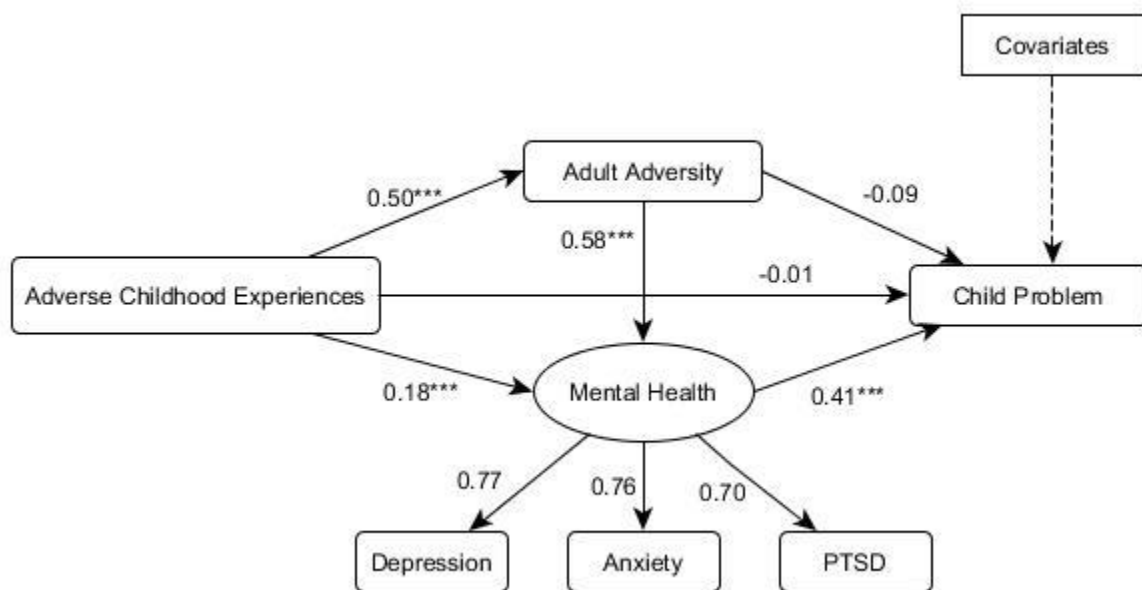

Coefficients are standardized. *** $P < 0.001$.

CHAPTER 5

Conclusion

The purpose of this dissertation was to generate new knowledge about the prevalence and consequences of adverse childhood experiences, and to help promote evidence-informed and culturally appropriate preventions and interventions. Toward these ends three separate studies were conducted. The first dissertation study is a longitudinal ACEs study. Using national data from the Fragile Families and Child Well-being Study (FFCWS), this study explored bidirectional relationships between ACEs and internalizing/externalizing problems in early childhood through middle adolescence. The second dissertation study is a cross-cultural ACEs Study. Original data was collected from over 1,000 high school graduates in China to test the effects of ACEs on psychosocial well-being in emerging adulthood. The third dissertation study is an intergenerational ACEs study. Adopting data from Wisconsin Families and Children Thriving (FACT) Study, this study explored how mothers' exposure to ACEs could affect the socio-emotional development of their children, and if mothers' mental health problems and cumulative adult adversity would mediate the association between mothers' ACE scores and their children's socio-emotional problems.

Results from the three dissertation studies suggest that ACEs were prevalent among economically disadvantaged populations. Over 80% of study participants had exposed to at least 1 typical ACE in the three studies. Furthermore, exposure to ACEs could impact individuals' psychosocial functioning from early childhood through next generation. Specifically, the first study revealed that although the bidirectional relationship between ACEs and child internalizing/externalizing problems was not always significant from early childhood through middle adolescence, earlier ACEs did significantly predict child anxious/depressive problems and aggressive problems at age 9. Also, child aggressive problems at age 5 significantly increased ACEs exposure at age 9. The second dissertation study demonstrated that ACEs were significantly related with Chinese young adults' psychological problems, including anxiety, depression, perceived stress, traumatic stress,

loneliness, and suicide intention. The third dissertation study highlighted that maternal ACEs was significantly related with children's socio-emotional problems, but not with socio-emotional competence. Also, the relationship between maternal ACEs and children's socio-emotional problems was mediated by maternal mental health problems and adult adversity.

Strengths and Limitations

This dissertation has the potential to contribute to research in many ways. The first study adopted the random intercept cross-lagged panel model to reveal the longitudinal and bidirectional relationships between ACEs and child development trajectories. Both the research method and findings are novel in literature. The second study generated new knowledge about the prevalence of conventional ACEs measure and other potential indicators of adversity in China, like gambling, financial hardship, and parental absence. It also documented the prevalence and consequences of ACEs among rural Chinese young adults, which had not been studied before. The third study findings not only help deepen our understanding of intergenerational impacts of ACEs, but also revealed new mechanisms through which maternal ACEs impact children's outcomes.

Of course, this dissertation research is not free from limitations. First of all, the three dissertation studies all relied on self-report data, which have obvious limitations. It is possible, for instance, that participants' ACEs and psychosocial problems were both underreported because of social desirability. Second, all the three study samples were economically disadvantaged populations. Therefore, study results may not be generalizable to other populations. Third, all the three studies used cumulative scores for ACEs, and each type of ACE was weighted equally. But the severity, timing, and duration of each adversity were not considered. These factors may have different effects on health development. Finally, research has demonstrated that protective factors, especially the stable relationships with caring and supportive adults, can buffer the detrimental effects of adverse childhood

experiences (National Scientific Council on the Developing Child, 2015). However, all the three studies only highlighted the negative impacts of childhood adversity, no protective factors which may counterbalance the effects of adversity was considered.

Implications and Future Directions

Taken together, findings from this dissertation research point to several practice and policy recommendations related to prevention and intervention. First, prevention and early intervention is very necessary. Results of this dissertation suggest that even young children aged 12 months to 36 months were affected indirectly by their mothers' adverse experiences. Other research has also confirmed that well-implemented "research-based" prevention or early intervention programs for youth can achieve significantly more benefits than costs (Aos, Lieb, Mayfield, Miller, & Pennucci, 2004). Therefore, prevention and early intervention not only can prevent further adversity and trauma for children and families, but also save societal cost in the long run.

Second, lifetime monitoring of adversity and health outcomes for at-risk populations is strongly recommended. The dissertation findings demonstrated that ACEs would impact individuals' psychological health at every life stage: childhood, adolescence, adulthood, even next generation. Not surprisingly, childhood adversity also significantly increased the exposure of adult adversity. Thus, ongoing monitoring, assessment and intervention is necessary to break the trajectories of childhood adversity, adulthood adversity, and related negative health outcomes.

Third, culturally appropriate prevention and intervention should be emphasized in practice. The second dissertation study revealed that some childhood adversities like parental absence and parental problematic gambling were especially prevalent among rural Chinese children. Moreover, the third dissertation study showed that social adversity like discrimination was very prevalent among low-income women. Practitioners should keep

these social cultural differences in mind, and implement culturally appropriate programs and services to address ACEs and trauma.

Lastly, special attention should be paid to individuals' psychological health in China. This dissertation research found that psychological health problems were severe among rural Chinese young adults. However, not as obvious as physical health problems, psychological health problems very often are not paid enough attention in less developed countries like China. For example, in 2012, researchers reported that approximately 173 million Chinese were estimated to have diagnosable mental illnesses or psychiatric disorders. But 158 million people never sought treatment (Xiang, Yu, Ungvari, Lee, & Chiu, 2012). Furthermore, China faces big deficits in mental health resources (Xiang, Ng, Yu, & Wang, 2018). In the near future, China Government need to reform its public health system and policies, and invest more in the mental health area to tackle its mental health crisis.

Turning to future research, there are two broad implications that stem from this dissertation. First, ACEs measure should be expanded. Although many scholars have proposed alternative ACEs measures (Cronholm et al., 2015; Finkelhor, Shattuck, Turner, & Hamby, 2013; Mersky, Janczewski, & Topitzes, 2017), most studies still adopted the typical 10 types of ACEs, which ignores the broader community and social factors, such as poverty, food insecurity, homelessness, racism, as well as community violence. Future ACEs research should have a more precise understanding of broader environmental adversities, to inform prevention and intervention policies and services. Additionally, most ACEs studies relied too much on the cumulative ACEs score, which assigns the same weight to each ACE. Future research should also explore the effects of timing, severity, and duration of adversities, to build a more precise and sensitive ACEs measure. Second, like the current dissertation research, most ACEs studies didn't consider any protective factors that might buffer the effect of ACEs on individuals' health development. Future ACE research should include

protective factors like care and support from adults or peers to determine if they promote resilience in the face of adversity.

References

- Aos, S., Lieb, R., Mayfield, J., Miller, M., & Pennucci, A. (2004). Benefits and Costs of Prevention and Early Intervention Programs for Youth. Retrieved from http://www.wsipp.wa.gov/ReportFile/881/Wsipp_Benefits-and-Costs-of-Prevention-and-Early-Intervention-Programs-for-Youth_Summary-Report.pdf
- Cronholm, P. F., Forke, C. M., Wade, R., Bair-Merritt, M. H., Davis, M., Harkins-Schwarz, M., Pachter, L. M., Fein, J. A. (2015). Adverse childhood experiences: Expanding the concept of adversity. *American Journal of Preventive Medicine*, 49(3), 354-361.
- Finkelhor, D., Shattuck, A., Turner, H. A., & Hamby, S. (2013). Improving the adverse Childhood Experiences Study scale. *JAMA Pediatrics*, 167(1), 70-75.
- Mersky, J. P., Janczewski, C. E., & Topitzes, J. (2017). Rethinking the measurement of adversity: moving toward second-generation research on adverse childhood experiences. *Child Maltreatment*, 22(1), 58-68.
- National Scientific Council on the Developing Child. (2015). Supportive Relationships and Active Skill-Building Strengthen the Foundations of Resilience: Working Paper 13. Retrieved from <http://www.developingchild.harvard.edu>
- Xiang, Y., Ng, C. H., Yu, X., & Wang, G. (2018). Rethinking progress and challenges of mental health care in China. *World Psychiatry*, 17(2), 231-232.
- Xiang, Y., Yu, X., Ungvari, G. S., Lee, E. H. M., & Chiu, H. F. K. (2012). China's national mental health law: a 26-year work in progress. Doi: [https://doi.org/10.1016/S0140-6736\(11\)61704-2](https://doi.org/10.1016/S0140-6736(11)61704-2)

Appendix A
Measure of ACEs in FFCWS

ACEs	Year 3	Year 5	Year 9	Year 15
Physical abuse	<p>Subscales of the Parent-Child Conflict Tactics Scales (CTS-PC). If primary caregiver or other caregiver:</p> <ol style="list-style-type: none"> 1. Shook child 2. Hit child on bottom with some hard object (belt, hairbrush stick...) 3. Spanked child on the bottom with your bare hand 4. Slapped child on the hand, arm, or leg 5. Pinched child <p>Scoring method: for each item, responses were assigned a score (0 for never or not in the past year; 1 for event occurred once, 2 for twice, 4 for 3-5 times; 8 for 6-10 times; 15 for 11-20 times, and 25 for more than 20 times). The scores from each item were summed to get a domain score. The domain score then were transformed into a dichotomous variable considering domain score in the</p>	<p>Subscales of the Parent-Child Conflict Tactics Scales (CTS-PC). If primary caregiver and other caregiver:</p> <ol style="list-style-type: none"> 1. Shook child 2. Hit child on bottom with some hard object (belt, hairbrush stick...) 3. Spanked child on the bottom with your bare hand 4. Slapped child on the hand, arm, or leg 5. Pinched child <p>Scoring method: Same with year 3 physical abuse scoring method.</p> <p>Year 5 also considers if mother reported CPS concern about physical abuse. A confirmative response to the concern indicated an exposure.</p>	<p>Subscales of the Parent-Child Conflict Tactics Scales (CTS-PC). If primary caregiver and other caregiver:</p> <ol style="list-style-type: none"> 1. Shook child 2. Hit child on bottom with some hard object (belt, hairbrush stick...) 3. Spanked child on the bottom with your bare hand 4. Slapped child on the hand, arm, or leg 5. Pinched child <p>Scoring method: Same with year 3 physical abuse scoring method.</p> <p>Year 9 also considers if mother reported CPS concern about physical abuse. A confirmative response to the concern indicated an exposure.</p>	<p>Subscales of the Parent-Child conflict Tactics Scales (CTS-PC). Primary caregiver report:</p> <ol style="list-style-type: none"> 1. Hit or slapped youth in past year <p>Scoring method: A reply of “often” as opposed to “never” and “sometimes” indicates high risk for physical abuse.</p> <p>Year 15 also considers if mother reported CPS concern about physical abuse. A confirmative response to the concern indicated an exposure.</p>

	top 10 th percentile of the whole sample as high risk for physical abuse.			
Neglect	<p>Subscales of the Parent-Child Conflict Tactics Scales (CTS-PC): primary caregiver and other caregiver:</p> <ol style="list-style-type: none"> 1. Left child home alone, but thought some adult should be with (him/her) 2. You are caught up with your own problem that you were not able to show love to child 3. Were not able to make sure child got the food he/she needed 4. Not able to make sure child got a doctor or hospital when needed 5. Were so drunk/high that you had a problem taking care of your child <p>Scoring method: same with CTS-PC physical abuse scoring method. Domain score in the top 10th percentile of the whole sample indicated high risk for neglect.</p>	<p>Subscales of the Parent-Child Conflict Tactics Scales (CTS-PC): primary caregiver and other caregiver:</p> <ol style="list-style-type: none"> 1. Left child home alone, but thought some adult should be with (him/her) 2. You are caught up with your own problem that you were not able to show love to child 3. Were not able to make sure child got the food he/she needed 4. Not able to make sure child got a doctor or hospital when needed 5. Were so drunk/high that you had a problem taking care of your child <p>Scoring method: same with year 3 scoring method.</p> <p>Year 5 also considers if mother reported CPS concern about neglect. Confirmative response indicated exposure.</p>	<p>Subscales of the Parent-Child Conflict Tactics Scales (CTS-PC): Parent</p> <ol style="list-style-type: none"> 1. Left child home alone, but thought some adult should be with (him/her) 2. You are caught up with your own problem that you were not able to show love to child 3. Were not able to make sure child got the food he/she needed 4. Not able to make sure child got a doctor or hospital when needed 5. Were so drunk/high that you had a problem taking care of your child <p>Scoring method: same with year 3 scoring method.</p> <p>Year 9 also considers if mother reported CPS concern about neglect. Confirmative response indicated exposure.</p>	<p>Year-15 only has information on CPS concern about neglect.</p> <p>Scoring method: A confirmative response to the concern indicated an exposure.</p>

Emotional abuse	<p>Subscales of the Parent-Child Conflict Tactics Scales (CTS-PC): primary caregiver and other caregiver:</p> <ol style="list-style-type: none"> 1. Shouted, yelled, or screamed at child 2. Swore or cursed at child 3. Said you would send child away or would kick child out of the house 4. Threatened to spank or hit child but did not actually do it 5. Called child dumb or lazy, or some other name like that <p>Scoring method: same with CTS-PC physical abuse scoring method. Domain score in the top 10th percentile of the whole sample indicated high risk for emotional abuse.</p>	<p>Subscales of the Parent-Child Conflict Tactics Scales (CTS-PC): primary caregiver and other caregiver:</p> <ol style="list-style-type: none"> 1. Shouted, yelled, or screamed at child 2. Swore or cursed at child 3. Said you would send child away or would kick child out of the house 4. Threatened to spank or hit child but did not actually do it 5. Called child dumb or lazy, or some other name like that <p>Scoring method: same with year 3 scoring method.</p>	<p>Subscales of the Parent-Child Conflict Tactics Scales (CTS-PC): mom, dad, partner, primary caregiver:</p> <ol style="list-style-type: none"> 1. Shouted, yelled, or screamed at child 2. Swore or cursed at child 3. Said you would send child away or would kick child out of the house 4. Threatened to spank or hit child but did not actually do it 5. Called child dumb or lazy, or some other name like that <p>Scoring method: same with year 3 scoring method.</p>	<p>Subscales of the Parent-Child conflict Tactics Scales (CTS-PC). Primary caregiver report:</p> <p>Shouted, yelled, screamed or swore at youth in past year</p> <p>Scoring method: A reply of “often” as opposed to “never” and “sometimes” indicates high risk for emotional abuse.</p>
Sexual abuse	Not asked in Year-3 survey.	Year-5 considers if mother reported CPS concern about sexual abuse. A confirmative response to the concern indicated an exposure.	Year-9 considers if mother reported CPS concern about sexual abuse. A confirmative response to the concern indicated an exposure.	Year-15 considers if mother reported CPS concern about sexual abuse. A confirmative response to the concern indicated an exposure.

<p>Mother treated violently</p>	<p>If child father or current partner:</p> <ol style="list-style-type: none"> 1. Slaps or kicks you 2. Hits you with a fist or an object that could hurt you 3. Tries to make you have sex or do sexual things you don't want to do 4. Slapped or kicked you in front of child? 5. Slapped or kicked you while child was in the house? 6. Hit you with a fist or an object that could hurt you in front of child 7. Hit you with a fist or an object that could hurt you while child was in the house 8. Since child's 1st birthday, have you been seriously hurt in fight with father/current partner? 9. Did father/current partner hurt you in front of child? <p>Scoring method: For questions 1-3, a reply of "sometimes" or "often" as opposed to "never", indicated an exposure. For questions 4-9, any affirmative response indicated exposure.</p>	<p>If child father or current partner:</p> <ol style="list-style-type: none"> 1. Slaps or kicks you 2. Hits you with a fist or an object that could hurt you 3. Tries to make you have sex or do sexual things you don't want to do 4. Throw something at you 5. Push, grab or shove you 6. You and father/current partner had a physical fight in front of child in the last 2 years 7. You have been seriously hurt in a fight with father/current partner in the last 2 years 8. Did father/current partner hurt you in front of child? <p>Scoring method: For questions 1-5, a reply of "sometimes" or "often" as opposed to "never", indicated an exposure. For questions 6-8, any affirmative response indicated exposure.</p>	<p>If child father or current partner:</p> <ol style="list-style-type: none"> 1. Slaps or kicks you 2. Hits you with a fist or an object that could hurt you 3. Tries to make you have sex or do sexual things you do not want to do 4. Throw something at you. 5. Push, grab or shove you. 6. You and father/current partner had a physical fight in front of child in the last 2 years 7. You have been seriously hurt in a fight with father/current partner in the last 2 years 8. Did father/current partner hurt you in front of child? <p>Scoring method: For questions 1-5, a reply of "sometimes" or "often" as opposed to "never", indicated an exposure. For questions 6-8, any affirmative response indicated exposure.</p>	<p>Primary caregiver:</p> <ol style="list-style-type: none"> 1. Had physical fight with spouse/partner in front of youth in past year 2. Seriously hurt in a fight with spouse/partner in past year 3. Spouse/partner hurt you in front of youth in past year 4. Had physical fight with spouse/partner since last interview 5. Seriously hurt in a fight with spouse/partner since last interview 6. Spouse/partner hurt you in front of youth since last interview <p>Scoring method: affirmative response to any of above questions indicated exposure.</p>
---------------------------------	--	--	---	--

Household substance abuse	<p>1. Does father have problems such as keeping a job or getting along with family and friends because of alcohol or drug use?</p> <p>2. Does (current partner) have problems such as keeping a job or getting along with family and friends because of alcohol or drug use?</p> <p>3. In the past 12 months, was there ever a time when your (mother) drinking or being hung over interfered with your work at school, or a job, or at home?</p> <p>4. Did you (mother) use any of these drugs on your own during the past 12 months?</p> <p>Scoring method: any affirmative response to the above questions indicated exposure.</p>	<p>1. Father have problems keeping job, getting along family/friends b/c alcohol/drugs?</p> <p>2. Current partner has problems keeping job/getting along w/family/friends b/c alcohol/drug?</p> <p>3. In last year, did drinking/hangover interfere with your (mother's) work at school/job/home?</p> <p>4. During the past 12 months, did you use any of the drugs?</p> <p>Scoring method: any affirmative response to the above questions indicated exposure.</p>	<p>1. Father has problems because of alcohol or drug use</p> <p>2. Current partner has problems because of alcohol or drug use</p> <p>3. Mother has problems because of alcohol or drug use</p> <p>4. Mother's Drinking/hangover interfered with work at school/job/home during past 12 months</p> <p>5. Mother used one of drugs</p> <p>Scoring method: any affirmative response to the above questions indicated exposure.</p>	<p>1. Spouse/partner has alcohol or drug use problems.</p> <p>2. Nonresident parent has alcohol or drug use problems.</p> <p>3. (Primary caregiver) drinking alcohol interfered with responsibilities in past year</p> <p>4. (Primary caregiver) drank alcohol when someone could have been hurt in past year</p> <p>5. (Primary caregiver) had problems with people because of alcohol in past year</p> <p>6. (Primary caregiver) had legal problems because of alcohol in past year</p> <p>7. (Primary caregiver) ever used any illicit drugs in past year?</p> <p>Scoring method: For questions 1, 2, 7, any affirmative response indicated exposure. For questions 3-6, a reply of "more than one time" indicated exposure.</p>
---------------------------	---	---	--	---

Mental illness in household	1. Mother meets CIDI depression criteria (liberal) at year 3 Scoring method: any affirmative response indicated exposure.	1. Mother meets CIDI depression criteria (liberal) at year 5 Scoring method: any affirmative response indicated exposure.	1. Mother meets CIDI depression criteria (liberal) at year 9 Scoring method: any affirmative response indicated exposure.	1. Primary caregiver meets CIDI depression criteria (liberal) in past year or since last interview Scoring method: any affirmative response indicated exposure.
-----------------------------	--	--	--	--

<p>Criminal household member</p>	<p>1. Mother reported that father was in jail at year 1 interview. 2. Is father currently in jail? 3. What was (current partner) doing most of last week? (can indicate “in jail”) 4. Thinking about (that/the most recent) separation, why were you (mother) and (child) separated? (can indicate “in jail”) 5. Thinking about the second most recent separation, why were you and (child) separated (can indicate “in jail”)</p> <p>Scoring method: For questions 1 and 2, any affirmative response indicated exposure. For questions 3, 4, 5, a reply of “in jail” indicated exposure.</p>	<p>1. What was father doing in the last week-working (can indicate “in jail”) 2. Has father spent any time in jail in the past two years? 3. Is father currently in jail? 4. What was (current partner) doing most of last week (can indicate “in jail”) 5. What was the main reason he/she stopped living with you most of the time? (can indicate mother “in jail”) 6. What is the main reason child doesn't live with you all the time? (can indicate mother “in jail”)</p> <p>Scoring method: For questions 2 and 3, an affirmative response indicated exposure. For questions 1, 4, 5, 6, a reply of “in jail” indicated exposure.</p>	<p>1. What father was doing most of last week (can indicate “in jail”) 2. What current partner was doing most of last week (can indicate “in jail”) 3. Constructed item: mother and father reported that father in jail at nine-year interview Non parent caregiver report: child not living with biological mother because mother in jail</p> <p>Scoring method: For questions 1, 2, a reply of “in jail” indicated exposure. For question 3, an affirmative response indicated exposure.</p>	<p>1. Spouse/partner spent time in jail since last interview. 2. (Primary caregiver) spent time in jail since last interview. 3. Nonresident parent spent time in jail since last interview.</p> <p>Scoring method: any affirmative response to the above questions indicated exposure.</p>
----------------------------------	---	--	---	---

Appendix B

Measure of Child Internalizing/Externalizing Problems in FFCWS

CBCL subscales	Year 3	Year 5	Year 9	Year 15
Anxious/ Depressed	<ol style="list-style-type: none"> 1. Clings to adults 2. Feelings hurt easily 3. Too upset by separation 4. Look unhappy 5. Nervous/high strung 6. overtired 7. Self-conscious/easily embarrassed 8. Too shy or timid 9. Too fearful or anxious 10. Unhappy, sad, depressed 11. Wants a lot of attention 	<ol style="list-style-type: none"> 1. (he/she) complains of loneliness 2. Child cries a lot 3. (he/she) fears that (he/she) might think or do something bad 4. (he/she) feels (he/she) has to be perfect 5. (he/she) feels or complains that no one loves (him/her) 6. (he/she) feels others are out to get (him/her) 7. Child feels worthless or inferior 8. Child is nervous, high strung, or tense 9. Child is too fearful or anxious 10. (he/she) feels too guilty 11. (he/she) is self-conscious or easily embarrassed 12. (he/she) is suspicious 13. Child is unhappy, sad, depressed 14. (he/she) worries 	<ol style="list-style-type: none"> 1. Child cries a lot 2. Child fears certain animals, situations, or places, other than school 3. Child fears going to school 4. Child fears he or she might do something bad 5. Child feels he or she has to be perfect 6. Child feels or complains that no one loves him or her 7. child feels worthless or inferior 8. Child is nervous, high-strung or tense 9. Child is too fearful or anxious 10. Child feels too guilty 11. Child is self-conscious or easily embarrassed 12. Child talks about killing self 13. Child worries 	<ol style="list-style-type: none"> 1. Child cries a lot 2. Child feels worthless or inferior 3. Child is nervous, high-strung, or tense 4. Child is too fearful or anxious 5. Child feels too guilty 6. Child worries

Withdrawn	<ol style="list-style-type: none"> 1. Acts too young for age 2. Avoids eye contact 3. Doesn't answer when spoken to 4. Doesn't get along with other children 5. Doesn't know how to have fun 6. Doesn't seem to feel guilty after misbehaving 7. Refuses to play games 8. Unresponsive to affection 9. Shows little affection 10. Shows little interest in things 11. Stubborn, sullen, or irritable 12. Uncooperative 13. Under active, slow moving or lacks energy 14. Withdrawn /doesn't get involved with others 	<ol style="list-style-type: none"> 1. Child would rather be alone than with others 2. Child refuse to talk 3. Child is secretive, keeps things to self 4. Child is shy or timid 5. Child stares blankly 6. Child sulks a lot 7. Child is underactive, slow moving, lacks energy 8. Child is unhappy, sad, or depressed 9. Child is withdrawn, doesn't get involve with others 	<ol style="list-style-type: none"> 1. Child enjoys very little 2. Child would rather be alone than with others 3. Child refuses to talk 4. Child is secretive, keep things to self 5. Child is shy or timid 6. Child is underactive, slow moving, o lacks energy 7. Child is unhappy, sad, or depressed 8. Child is withdrawn, doesn't get involved with others 	<ol style="list-style-type: none"> 1. Child is underactive, slow moving or lacks energy 2. Child is unhappy, sad or depressed
Aggressive	<ol style="list-style-type: none"> 1. He/she is Defiant 2. His/her demands must be met immediately 3. He/she is disobedient 4. He/she is easily frustrated 5. He/she is easily jealous 6. He/she gets in many fights 7. He/she hits others 8. He/she has angry moods 	<ol style="list-style-type: none"> 1. Child argues a lot 2. Child brags or boasts 3. Child is cruel, bullying, or mean to others 4. Child demands a lot of attention 5. Child destroys his/her own things 	<ol style="list-style-type: none"> 1. Child argues a lot 2. Child is cruel, bullies, or shows meanness to others 3. Child demands a lot of attention 4. Child destroys his or her own things 5. Child destroys things belonging to family or others 	<ol style="list-style-type: none"> 1. Child is cruel, bullies, or shows meanness to others 2. Child destroys things belonging to the family or others 3. Child is disobedient at home 4. Child is disobedient at school 5. Child gets in many fights

	<ul style="list-style-type: none"> 9. Punishment doesn't change (his/her)behavior 10. He/she screams a lot 11. He/she is selfish or won't share 12. He/she has sudden changes in mood or feelings 13. He/she has temper tantrums or hot temper 14. He/she is unusually loud 15. He/she is whiny 	<ul style="list-style-type: none"> 6. Child destroys things belong to his/her family or others 7. He/she is disobedient at home 8. He/she is disobedient in school or in childcare 9. Child is easily jealous 10. He/she gets in many fights 11. Child physically attacks people 12. Child screams a lot 13. Child is showing off or clowning 14. Child is stubborn, sullen, or irritable 15. Child has sudden changes in mood of feelings 16. Child talks too much 17. Child teases a lot 18. Child has temper tantrums or hot temper 19. Child threatens people 20. Child threatens people 	<ul style="list-style-type: none"> 6. Child is disobedient at home 7. Child is disobedient at school 8. Child gets in many fights 9. Child physically attacks people 10. Child screams a lot 11. Child is stubborn, sullen or irritable 12. Child has sudden changes in mood or feelings 13. Child sulks a lot 14. Child is suspicious 15. Child teases a lot 16. Child has temper tantrums or a hot temper 17. Child threatens people 18. Child is unusually loud 	<ul style="list-style-type: none"> 6. Child physically attacks people 7. Child is stubborn, sullen, or irritable 8. Child has temper tantrums or a hot temper 9. Child threatens people 10. Child is unusually loud 11. Child argues a lot
Destructive/ Delinquent	<ul style="list-style-type: none"> 1. Child can't concentrate, can't pay attention for long 2. Child is cruel to animal 3. Child destroys his/her own things 	<ul style="list-style-type: none"> 1. Not seems to feel guilty after misbehaving 2. Hangs around with others who get in trouble 3. Lying or cheating 4. Prefers being with older kids 	<ul style="list-style-type: none"> 1. child drinks alcohol without parents' approval 2. Child doesn't seem to feel guilty after misbehaving 3. Child breaks rules at home, school or elsewhere 4. Child lies or cheats 	<ul style="list-style-type: none"> 1. Child doesn't seem to feel guilty after misbehaving 2. Child hangs around with others who get in trouble 3. Child lies or cheats 4. Child runs away from home

	<p>4. Child destroys things belonging to his family or other children</p> <p>5. Child gets into everything</p> <p>6. Child hurts animals or people without meaning to</p> <p>7. Child quickly shifts from one activity to another</p>	<p>5. Runs away from home</p> <p>6. Sets fire</p> <p>7. Steals at home</p> <p>8. Steals outside home</p> <p>9. Swears or uses obscene language</p> <p>10. Vandalizes</p>	<p>5. Child prefers being with older kids</p> <p>6. Child runs away from home</p> <p>7. Child sets fires</p> <p>8. Child has sexual problems</p> <p>9. Child steals at home</p> <p>10. Child steals outside the home</p> <p>11. Child swears or uses obscene language</p> <p>12. Child think about sex too much</p> <p>13. Child smokes, chews or niffs tobacco</p> <p>14. Child is truant, skips school</p> <p>15. Child uses alcohol or drugs for nonmedical purposes</p> <p>16. Child vandalizes</p>	<p>5. Child sets fires</p> <p>6. Child steals at home</p> <p>7. Child steals outside the home</p> <p>8. Child swears or uses obscene language</p> <p>9. Child vandalizes</p>
--	---	--	---	--

Appendix C
Model Fit Index

	RMSEA	CFI	TLI	SRMR
Anxious	0.031	0.960	0.922	0.020
Withdrawn	0.024	0.971	0.948	0.019
Aggressive	0.022	0.984	0.971	0.015
Delinquent	0.014	0.990	0.981	0.013

CURRICULUM VITAE

Lixia Zhang

EDUCATION

PhD	School of Social Welfare, University of Wisconsin-Milwaukee	Aug 2019
MSW	School of Social Welfare, University of Wisconsin-Milwaukee	Dec 2014
MA	School of Foreign Languages, East China Normal University	June 2010
BA	School of Foreign Languages, Huaibei Normal University	June 2006

RESEARCH INTERESTS

Adverse childhood experiences (ACEs), toxic stress, trauma and resilience, children and youth development, intergenerational transmission of ACEs, cross-cultural childhood adversity and trauma, translational research

TEACHING INTERESTS

Research Methods, Evaluation of Practice, Program Evaluation, Human Behavior and Social Environment, Social Work with Children and Families, Trauma Theory and Research

PROFESSIONAL EXPERIENCE

Aug 2019 - Present Assistant Professor University of Northern Iowa

GRANTS AND FELLOWSHIPS

Funded Research Grants

- 2017-2020 The Construction of Knowledge Graph Concerning School Disciplinary Climate: From A Perspective of School Effectiveness. Amount: ¥40,000. Funded by: Shanghai Philosophy and Social Sciences Planning Project Funds (Specialized Planning of Education for Youth in Shanghai). Role: Co-Investigator
- 2016-2018 A Comparative Study of School Effectiveness between Shanghai and Hong Kong. Amount: ¥100,000. Funded by: Shanghai Pujiang Talents Planning Program. Role: Co-Investigator
- 2018-2020 The Study of Adolescents' Self-Management – Designing and Implementing Evidence-based Positive Behavioral Support Program. Funder: Botou Education Bureau in Hebei Province, China. Role: Co-Investigator

Fellowships

- 2017-2018 Distinguished Dissertation Fellowship. Amount: \$17,500
Funded by: University of Wisconsin-Milwaukee, Graduate School
- 2013-2014 Dean's Fellowship. Amount: \$20,000
Funded by: University of Wisconsin-Milwaukee, Helen Bader School of Social Welfare
- 2008-2009 Outstanding Graduate Student Fellowship. Amount: ¥15, 000
Funded by: East China Normal University, Graduate School
- 2007-2008 Fucheng-Shuqing Fellowship. Amount: ¥2,000
Funded by: East China Normal University, Graduate School
- 2008 China ShixueJuncai Fellowship. Amount: ¥5,000
Funded by: Peking University

AWARDS AND HONORS

- 2006 Outstanding Graduate of Anhui Province
Huaibei Normal University
- 2006 University Outstanding Graduate
Huaibei Normal University
- 2004 Excellent Volunteer in Summer Service for Farmers
Huaibei Normal University
- 2002-2004 Excellent Student Leader for Outstanding Leadership
Huaibei Normal University
- 2004-2005 Excellent Academic Scholarship, First Prize
Huaibei Normal University
- 2003-2004 Excellent Academic Scholarship, Second Prize
Huaibei Normal University

PUBLICATIONS

Peer-Reviewed Journal Articles

1. Blair, K., Voith, L., **Zhang, L.**, & Yoon, S. (2019). Expanding the scope of resilience research with socioeconomically disadvantaged men: Considering the sociocultural context. *Journal of Men's Studies*, 1-19.
2. Rolock, N., White, K. R., Ocasio, K., **Zhang, L.**, MacKenzie, M. J., Fong, R. (2018). A comparison of foster care reentry after adoption in two large U.S. states. *Research on Social Work Practice*. Doi: 10.1177/1049731518783857

3. Kavanaugh, M., Noh, H., & **Zhang, L.** (2016). Caregiving youth knowledge and perceptions of parental end-of-life wishes in Huntington's disease. *Journal of Social Work in End-of-life & Palliative Care*, 12(4), 348-365.
4. Kavanaugh, M., Stamatopoulos, V., Cohen, D., & **Zhang, L.** (2015). Unacknowledged caregivers: A scoping review of research on caregiving youth in the United States. *Adolescent Research Review*, 1(1), 29-49.
5. Gao, G., Chen, F., & **Zhang, L.** (2014). TALIS 2008 survey results: Professional teachers, effective teaching. *Shanghai Education*, 26, 1-4. (In Chinese).

Manuscripts under Review

1. **Zhang, L.**, & Mersky, J. Adverse childhood experiences and psychological wellbeing in a rural sample of Chinese young adults. *Child Abuse & Neglect*.

Manuscripts in Preparation

1. **Zhang, L.**, & Mersky, J. (Ready to submit). Bidirectional relations Between adverse childhood experiences and internalizing/externalizing problems from early childhood to middle adolescence.
2. **Zhang, L.** (Ready to submit). Intergenerational Effects of Maternal Adversity on Child Socio-Emotional Development.
3. Xu, Y., Man, X., **Zhang, L.**, & DeForge, B. (Draft available). Family foster care and children's outcomes in China: Evidence from a scoping review.
4. **Zhang, L.** (In progress). The impact of fathers' unwanted pregnancy on their engagement with young children in fragile families.

Other Publications

1. **Zhang, L.**, & Berger, L. (Accepted). Substance-abusing parents and their children: An interview with Dr. Joan Blakey and Dr. Christine Fewell. *Journal of Social Work Practice in the Addictions*.
2. Berger, L., & **Zhang, L.** (2016). Substance use and street violence: An interview with Ruben Burgos, senior lecturer in criminal justice and retired police lieutenant of the Milwaukee Police Department. *Journal of Social Work Practice in the Addictions*, 00:1-7.
3. Gao, G., Chen, F., & **Zhang, L.** (2016). *Creating Effective Teaching and Learning Environments: First Results from TALIS*. OECD (Eds). Peking University Press, Beijing. (Translated book in Chinese).

PEER REVIEWED CONFERENCE PRESENTATIONS

1. **Zhang, L.**, & Mersky, J. (2019, January). Adverse Childhood Experiences and Behavioral Trajectories from Early Childhood to Adolescence. Oral paper presented at the

23rd Annual Conference of the Society for Social Work and Research (SSWR), San Francisco, CA.

2. Man, X., Xu, Y., **Zhang, L.**, & DeForge, B. (2018, November). Family Foster Care and Children's Outcomes in China: Evidence from a Scoping Review. Oral paper to be presented at the 64th Annual Program Meeting of the Council on Social Work Education, Orlando, FL.

3. Rolock, N., White, K. R., Ocasio, K., **Zhang, L.**, MacKenzie, M. J., & Fong, R. (2018, July). An Examination of Post-Adoption Experiences of Children, Young Adults, and Families in the U.S. Symposium presentation at the 6th Edition of the International Conference on Adoption Research (ICAR), Montreal, Canada.

4. **Zhang, L.**, Mersky, J., & Topitzes, J. (2018, June). Cross-cultural Research on Adverse Childhood Experiences: Prevalence and Consequences among Chinese Youth. Poster presented at the 25th Annual Colloquium of the American Professional Society on the Abuse of Children (APSAC), New Orleans, LA.

5. Rolock, N., White, K. R., Ocasio, K., **Zhang, L.**, MacKenzie, M. J., & Fong, R. (2018, April). Using Administrative Data to Understand Longitudinal Postadoption Outcomes. Poster presented at the Rudd Adoption Research Conference, Amherst, MA. **Winner of the Outstanding Poster Presentation Award.**

6. **Zhang, L.**, & Gao, G. (2017, January). Making a Colorful PLATE: Exploring New Teaching Methods for Social Work Research Methods Class. Oral paper presented at UWM 2017 Teaching and Learning Symposium, Milwaukee, WI.

7. Mersky, J., Janczewski, C., & **Zhang, L.** (2017, January). ACEs, Races, and Poverty: Racial/Ethnic Differences in Self-Reported Childhood Adversity in a Low-Income Sample. Oral paper presented at the 21st Annual Conference of the Society for Social Work and Research (SSWR), New Orleans, LA.

8. Cao, Y., & **Zhang, L.** (2016, November). Importance of Civic Responsibility and Child Maltreatment Risk: The Protective Role of Civic Engagement. Poster presented at 2016 American Public Health Association (APHA) Annual Meeting and Expo, Denver, CO.

9. **Zhang, L.**, & Gao, G. (2016, June). Impacts of Adverse Childhood Experiences on Fragile Family Children's Delinquent Behavior and Academic Achievement. Oral paper presented at the 24th Annual Colloquium of the American Professional Society on the Abuse of Children (APSAC), New Orleans, LA.

10. **Zhang, L.** (2016, January). How Unwanted Pregnancy for Fathers Impact their Engagement with Young Children in Fragile Families. Oral paper presented at the 20th Annual Conference of Society for Social Work and Research (SSWR), Washington, DC.

11. Kavanaugh, M., Noh, H., & **Zhang, L.** (2016, January). "I Wish I Knew What He Wanted": An Exploration of Youth Caregivers' Understanding of Parental End of Life Wish. Oral paper presented at the 20th Annual Conference of the Society for Social Work and Research (SSWR), Washington, DC.

12. **Zhang, L.** (2015, September). Fathers' Engagement with Young Children in Fragile Families. Workshop presented at the 29th Annual Children's Network Conference, Ontario, CA.

13. **Zhang, L.** (2015, July). The Impacts of Adverse Childhood Experiences on Young Children's Behavioral Problems and Developmental Delays. Oral paper presented at the 23rd Annual Colloquium of American Professional Society on the Abuse of Children (APSAC), Boston, MA.

RESEARCH EXPERIENCE

- 2017-Present Research Assistant
National Quality Improvement Center for Adoption and Guardianship Support and Preservation. Amount: \$25,000,000.
Funded by: U.S. Department of Health and Human Services, Administration for Children and Families, Administration on Children, Youth and Families.
Supervisor: Dr. Nancy Rolock (Co- Principal Investigator)
- 2016-2017 Research Assistant
Improving the Transition from Jail to the Community for Impoverished Women. Amount: \$25,000.
Funded by: UWM Social Compact Grants Program
Supervisor: Dr. Susan Rose (Principal Investigator)
- 2015-Present Student Principal Investigator
Childhood Adversity and Wellbeing of Chinese Youth (Dissertation Project)
Supervisor: Dr. Joshua Mersky (Principal Investigator)
- 2015-2016 Research Assistant
Expanding Home Visiting with Fidelity
Funded by: U.S. Department of Health and Human Services, Health Resources and Services Administration. Amount: \$13,927,566.
Supervisor: Dr. Joshua Mersky (Principal Investigator)
- 2015 Research Assistant
Qualitative Study on Young Caregivers Whose Parent with ALS
Supervisor: Dr. Melinda Kavanaugh (Principal Investigator)
- 2013-2014 Research Assistant
Alcohol and Energy Drink among College Students
Supervisor: Dr. Lisa Berger (Principal Investigator)
- 2012-2013 Research Assistant
Keeping Families Together: Investigation of Mothers on Jail
Funded by the Bureau of Justice Administration. Amount: \$50,000.
Supervisor: Dr. Susan Rose (Principal Investigator)

TEACHING EXPERIENCE

- 2018 Summer Instructor
Evaluation of Practice (Graduate Level)
University of Wisconsin-Milwaukee
- 2017 Spring Co-Instructor
Methods of Social Welfare Research (Graduate Level)
University of Wisconsin-Milwaukee
- 2015 Fall Guest Lecturer
Methods of Social Welfare Research (Graduate Level)
University of Wisconsin-Milwaukee
Topic: Purpose and Methods of Sampling in Social Work Research
- 2015 Fall Teaching Assistant
Methods of Social Welfare Research (Graduate Level)
University of Wisconsin-Milwaukee
- 2014 Fall Teaching Assistant
Methods of Social Welfare Research (Graduate Level)
University of Wisconsin-Milwaukee
- 2010 Spring Instructor
Comprehensive English for College Students
East China Normal University
- 2009 Fall Instructor
Comprehensive English for College Students
East China Normal University
- 2008 Fall Teaching Assistant
English Writing for College Students
East China Normal University
- 2008 Spring Teaching Assistant
English Writing for College Students
East China Normal University

NON-PROFIT WORKING EXPERIENCE

- 2014 Research Intern
Children's Hospital of Wisconsin-Community Service
Supervisor: Gabriel McGaughey (Director)
Responsible for: selecting measurements for child well-being project;
doing literature review on toxic stress and adversities; conducting data
analysis for monthly placement stability and child behavioral problems
treatment; aiding in program evaluation for family counseling department.
- 2013 Research Intern

Penfield Children's Center
Supervisor: Christine Holmes (CEO)
Responsible for: helping with office administration; assisting with data analysis for Child Behavior Clinic; helping with grant writing and fundraising events.

- 2011-2012 Program Coordinator
Steppingstones China, Shanghai
Supervisor: Corinne Hua (Founder & Executive Director)
Responsible for: coordinating 10 school and community programs for migrant children in Shanghai; liaising with community centers and schools teachers; assigning volunteers and managing assigned volunteers; liaising with volunteers, monitoring needed support and providing appropriate feedback.
- 2007-2010 Volunteer Coordinator
Steppingstones China, Shanghai
Supervisor: Corinne Hua (Founder & Executive Director)
Responsible for: coordinating 15 volunteers for a school program; liaising with school teachers; liaising with volunteers, monitoring needed support and providing appropriate feedback; organizing team-building activities.

SERVICE

- 2019 Committee Member
Annual Rewards Committee
Helen Bader School of Social Welfare
University of Wisconsin-Milwaukee
- 2017-Present Journal Reviewer
Perspectives on Social Work Journal
- 2017-2018 Graduate Student Representative
Graduate Faculty Committee
University of Wisconsin-Milwaukee
- 2017-2018 Committee Member
International Education Committee
Helen Bader School of Social Welfare
University of Wisconsin-Milwaukee
- 2017 Student Mentor
International Students Mentor Program
Center for International Education
University of Wisconsin-Milwaukee
- 2015-2016 Committee Member
Doctoral Students Recruitment Committee
Helen Bader School of Social Welfare
University of Wisconsin-Milwaukee

REFERENCES

- Dr. Joshua Mersky
(Advisor & Chair) Professor and Co-Director, Institute on Child and Family Welfare
Helen Bader School of Social Welfare
University of Wisconsin-Milwaukee
mersky@uwm.edu, (414)-229-5003
- Dr. Steven McMurtry Professor and Doctoral Program Director
Helen Bader School of Social Welfare
University of Wisconsin-Milwaukee
mcmurtry@uwm.edu, (414)-229-2249
- Dr. James (Dimitri)
Topitzes Associate Professor
Helen Bader School of Social Welfare
University of Wisconsin-Milwaukee
topitzes@uwm.edu, (414)-229-3004
- Dr. Susan Rose Professor
Helen Bader School of Social Welfare
University of Wisconsin-Milwaukee
sjrose@uwm.edu, (414)-229-6301