

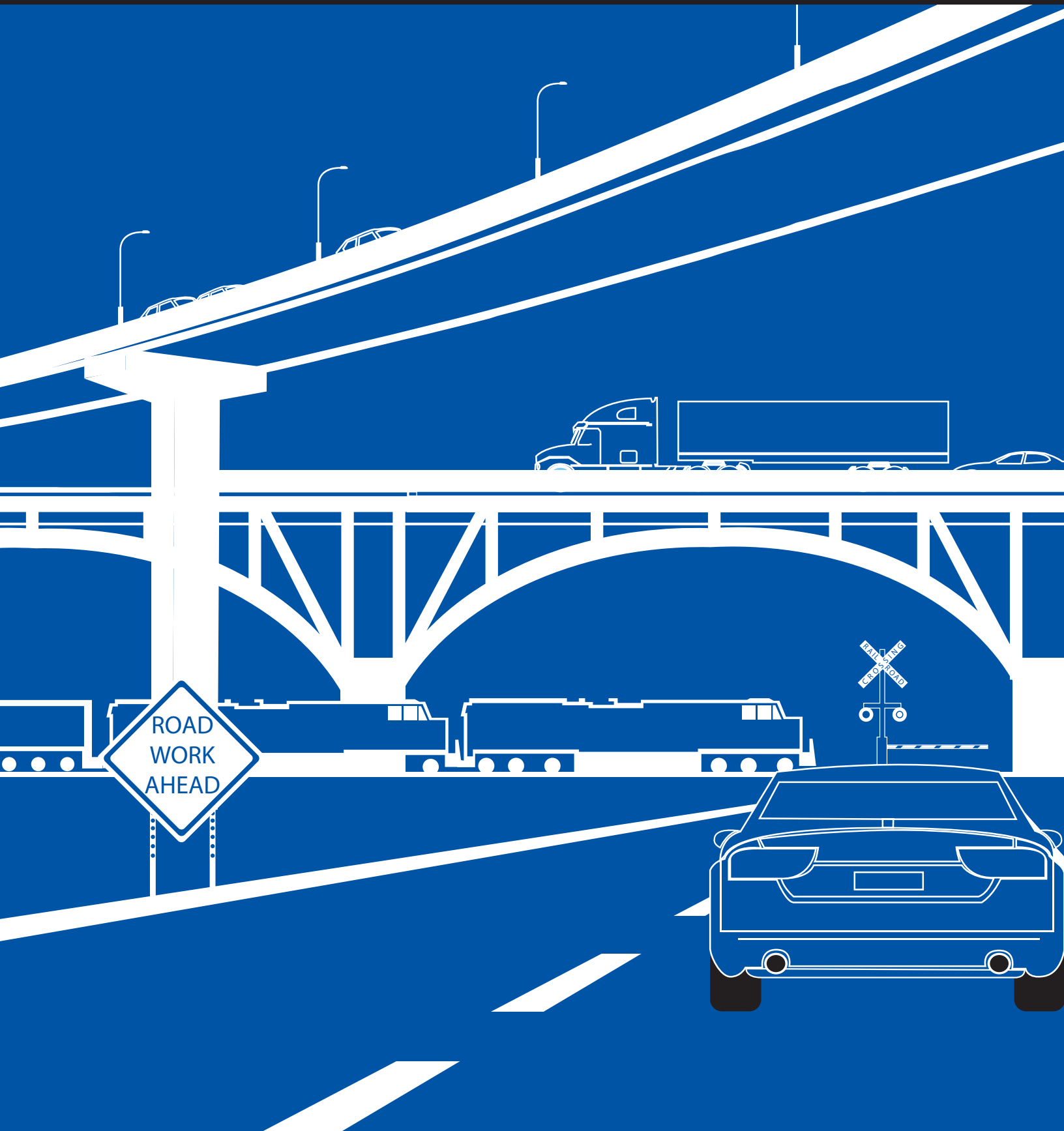

Investigating the Use of In-Place Lateral Pull Off Tests to Determine the Compressive Strength of Structural Concrete

Report Number: KTC-19-01/SPR17-541-1F

DOI: <https://doi.org/10.13023/ktc.rr.2019.01>



Kentucky Transportation Center
College of Engineering, University of Kentucky, Lexington, Kentucky

in cooperation with
Kentucky Transportation Cabinet
Commonwealth of Kentucky

The Kentucky Transportation Center is committed to a policy of providing equal opportunities for all persons in recruitment, appointment, promotion, payment, training, and other employment and education practices without regard for economic, or social status and will not discriminate on the basis of race, color, ethnic origin, national origin, creed, religion, political belief, sex, sexual orientation, marital status or age.

Kentucky Transportation Center
College of Engineering, University of Kentucky, Lexington, Kentucky

in cooperation with
Kentucky Transportation Cabinet
Commonwealth of Kentucky

© 2018 University of Kentucky, Kentucky Transportation Center
Information may not be used, reproduced, or republished without KTC's written consent.

Research Report
KTC-19-01/SPR17-541-1F

**Investigating the Use of In-Place Lateral Pull Off Tests to Determine the
Compressive Strength of Structural Concrete**

By

Charlie Sun, PhD, P.E.
Research Engineer

Kentucky Transportation Center
College of Engineering
University of Kentucky
Lexington, Kentucky

In cooperation with
Kentucky Transportation Cabinet
Commonwealth of Kentucky

The contents of this report reflect the views of the authors, who are responsible for the facts and accuracy of the data presented herein. The contents do not necessarily reflect the official views or policies of the University of Kentucky, the Kentucky Transportation Center, the Kentucky Transportation Cabinet, the United States Department of Transportation, or the Federal Highway Administration. This report does not constitute a standard, specification, or regulation. The inclusion of manufacturer names or trade names is for identification purposes and should not be considered an endorsement.

January 2019

1. Report No. KTC-19-01/SPR17-541-1F	2. Government Accession No.	3. Recipient's Catalog No.	
4. Title and Subtitle Investigating the Use of In-Place Lateral Pull Off Tests to Determine the Compressive Strength of Structural Concrete		5. Report Date January 2019	
		6. Performing Organization Code	
		8. Performing Organization Report No. KTC-19-01/SPR17-541-1F	
7. Authors Charlie Sun		10. Work Unit No. (TRIAS)	
9. Performing Organization Name and Address University of Kentucky College of Engineering Kentucky Transportation Center 176 Oliver Raymond Building Lexington, KY 40506-0281		11. Contract or Grant No. KYSPR-17-541	
12. Sponsoring Agency Name and Address Kentucky Transportation Cabinet 200 Mero Street Frankfort, KY 40622		13. Type of Report and Period Covered Final	
		14. Sponsoring Agency Code	
15. Supplementary Notes Prepared in cooperation with the Federal Highway Administration, US Department of Transportation			
16. Abstract The Kentucky Transportation Cabinet's current practice for determining the compressive strength of structural concrete consists of two methods. Both methods require that samples be delivered to an off-site facility for testing. Accordingly, affected parties on the project site must wait for the delivery of samples to the off-site facility, the performance of tests and analysis of test data, and the return of test results to the project site. Analysis of existing structural concrete requires core samples to be taken from the structural element in question. As a result, sample locations must be patched and repaired. Sampling can also potentially damage an element's structural integrity. A quick, on-site method that requires minimal repair is needed to determine the compressive strength of concrete. The lateral pull off test, which is conceptually and methodologically similar to the pull off/pull out test, can be used to determine the compressive strength of in-place concrete. It appears to be an accurate, non-destructive, and reliable method. This method also requires minimal patch work at sample locations. Samples are easily obtained and the test results are quickly determined on-site. Two series of tests — a laboratory test on freshly poured concrete slabs and an in-situ test on ready-to-demolish old bridges — were carried out. Both series of tests run the compressive strength cylindrical concrete test and lateral pull off test simultaneously to validate lateral pull off test as an acceptable and dependable method of determining concrete compressive strength. The test procedure and results look very promising based on the project's objective.			
17. Key Words		18. Distribution Statement Unlimited, with approval of the Kentucky Transportation Cabinet	
19. Security Classification (of this report) None	20. Security Classification (of this page) None	21. No. of Pages 35	22. Price

Table of Contents

Acknowledgements.....	i
Executive Summary	1
1. Introduction.....	1
1.1 Background	1
1.2 Problem Statement	1
2. Objectives	3
3. Test Procedures.....	4
3.1 Laboratory Test.....	5
3.1.1 Apparatus for Lateral Pull Off Test.....	6
3.1.2 Procedure for Lateral Pull Off Test.....	6
3.2 In-Situ Test.....	12
3.2.1 Apparatus for In-Situ Test.....	13
3.2.2 Procedure for In-Situ Lateral Pull Off Test.....	13
4. Test Results and Discussion.....	15
4.1 Laboratory Test Results	16
4.2 In-Situ Test Results.....	16
5. Conclusions and Future Works.....	18
References.....	19
Appendix A.....	21

List of Figures

Figure 1 Three (3) concrete slabs with dimensions of 30.5” (width) x 46.5” (length) x 5.5” (depth) and twenty (20) 4” (diameter) x 8” (length) cast-in-place cylinder modal concrete samples are poured in the garage.	5
Figure 2 Coring with a water-cooled 0.72 in. diamond coring bit takes place to full 2.76 in. depth of the coring bit.	6
Figure 3 Remove core and ensure the hole is cleaned out.	7
Figure 4 The centering brass rod is inserted in the hole and the diamond planning wheel is centered on the rod’s top. Planning takes place with water cooled to a 1/10 in. depth by pressing the units axel connected to the drill machine against the surface, which has to be plane in its total circumference. ..	7
Figure 5 Surface ground.....	8
Figure 6 The diamond recess router is inserted in the drilled hole and turned on. The bit is water cooled. The flange of the recess router must rest firmly against the planed surface.	8
Figure 7 Recess routing is done by pressing the flange of the router against the planed surface and moving it sideways in progressively larger circles until the recess router shaft follows the side face of the cored 0.72 in. hole. The diameter of the recess must be 1.0 ± 0.01 in. after routing and the depth to the recess 1.0 in.....	9
Figure 8 Hole with ground surface and undercut groove.....	9
Figure 9 The assembled expansion tool with installed expandable ring is inserted in the hole.	10
Figure 10 The expansion of the expandable ring is done by turning the big nut to the fully expanded position of the ring while keeping the center pull bolt in the same position.	11
Figure 11 The expandable insert expanded before and after. The left insert in both pictures is the shape before expansion; the right one in both pictures is the shape after expansion.....	11
Figure 12 After fully expanding the expandable ring in the routed recess the counter pressure is installed on the surface and the coupling threaded to the center pull bolt. The hydraulic CAPO-TEST instrument is coupled to the coupling and the slack removed between instrument and counter pressure. Loading is done by turning the instruments handle slowly.	12
Figure 13 Detect and draw the locations of reinforcement.....	14
Figure 14 Sample from Pendleton County shown inhomogeneous and very poor gradation.....	17

List of Tables

Table 1. A typical AA Concrete Mix Design (for a one cubic yard mix).....	6
Table 2. Summary of laboratory test results from lateral pull off and cylindrical concrete compressive strength	15
Table 3. Summary of in-situ test results from lateral pull off and cylindrical concrete compressive strength	16

Acknowledgements

The author would like to express his thanks to Tim Jones, transportation technician at KTC, for his help on running both compressive strength cylindrical concrete test and lateral pull off test.

The author further wishes to thank and acknowledge the members of the Study Advisory Committee. Their guidance and advice during the course of this study was most helpful. In particular, the authors would like to thank Mr. Ryan Gossom, Division of Construction, Chairman of the Study Advisory Committee, for his leadership.

Executive Summary

The Kentucky Transportation Cabinet's (KYTC) current practice for determining the compressive strength of structural concrete consists of two methods. Both methods require the delivery of samples to an off-site facility for testing. As such, affected parties on the project site must wait for the delivery of samples to the off-site facility, the performance of tests and analysis of test results, and the return of results to the project site. Analysis of existing structural concrete requires core samples be taken from the structural element in question. As a result, sample locations must be patched and repaired, which can potentially damage an element's structural integrity. A quick, on-site method with minimal repair is needed to determine the compressive strength of concrete. The lateral pull off test (which uses a similar principle and procedure as the pull off/pull out test) can be used to determine the compressive strength of in-place concrete. It appears to be an accurate, non-destructive, and reliable procedure. This method also requires minimal patch work at sample locations. Samples are easily obtained and the test results are determined quickly on-site. Two series of tests — a laboratory test on freshly poured concrete slabs and an in-situ test on ready-to-demolish old bridges — were carried out. Both series of tests run the compressive strength cylindrical concrete test and lateral pull off test simultaneously to validate the lateral pull off test as an acceptable and trustworthy method of determining concrete compressive strength. The largest difference of average strengths from the compressive strength cylindrical concrete test is 2.488% greater than those obtained from the lateral pull off test. This small bias is believed to be of no practical significance for the purpose of strength evaluation of concrete. The test procedure and results look very promising based on the project's objective.

Based on the analysis presented in this report, KTC researchers have reached the following conclusions:

- (1) The lateral pull off test is a viable complement for testing cores, provided the concrete in the 1 in. (25 mm) cover layer is representative of the interior concrete. This opens up the possibility of testing existing concrete structures with the lateral pull off test at a much higher testing frequency than is possible using cores alone. Compared with core testing, the lateral pull off test is less expensive, test results are obtained immediately, and there is little damage inflicted on the structure needing repair. It is recommended, however, that a limited number of cores always be taken to confirm that the correlation being used is applicable to the concrete in the structure.
- (2) The lateral pull off test is a viable option if the concrete grading is good and the maximum aggregate size 1.25 in. (32 mm). It is important to scrutinize the uniformity of the aggregate grading and the maximum aggregate size on the tested structure.
- (3) Usually, no large aggregates are present in the 1 in. (25 mm) cover, but if they are, the lateral pull off test performed through a large, hard aggregate, will give a high strength relative to a concrete with no large aggregates (as the test results for the KY-159 bridge over Kincaid Creek, Pendleton County, indicate).

With respect to implementation, the test device can be transferred to KYTC for future use. KTC researchers are also ready to assist with further activities at the request of the Cabinet, such as:

- (1) Test demonstration and/or a video of a test demonstration to optimize implementation.

(2) Test demonstration on a pilot project to help bridge the gap between the research and its implementation.

The second option would give KTC the opportunity to promote the test method in practice.

1. Introduction

1.1 Background

In reinforced concrete structures, the strength of concrete is one of the most important properties, and is the main parameter used for design. Identifying methods to evaluate this property in finished structures or structures in use, without damaging its functionality or appearance, has concerned engineering professionals over the years. There are many test methods to evaluate concrete strength. The most frequently used test measures the compressive strength of concrete at the age of 28 days using simple compression in cylindrical and prismatic specimens. The simple compression test on cylindrical specimens is standard in the United States. Despite the ease of implementing this kind of test, both in terms of specimen preparation and obtaining results, the test requires planning before the execution of structures through the creation of test specimens. This does not favor inspections in finished structures or control the development of the material resistance over time.

In recent decades, other tests have been developed, such as non-destructive tests. These tests are faster, simpler, and more economical processes for obtaining information on concrete properties. Once they are run, these tests also return an estimate for the compression strength of the measured concrete in-situ, eliminating the need for extracting many specimens to determine the compressive strength of inspected structures. One of the most popular tests is pull off/pull out test, which has been presented as viable alternative to compression testing on cylindrical specimens.

Different researchers [ACI228.1R, 2003; Bickley, 1982, 1984; Carrette and Malhotra 1984; Carino, 2004; Dilly and Ledbetter, 1984; Hindo and Bergstrom, 1985; Khoo, 1985; Malhotra and Carrette, 1980; Parsons and Naik, 1984; Petersen, 1997; Richards, 1977; Soutsos, Bungey, and Long; 2005; Stone and Giza, 1985; Vogt, Beizai, and Dilly, 1984; Yener and Chen, 1984] have reviewed their experiences using pull off/pull out test equipment. The pull off/pull out test does little damage to the inspected part, can be implemented in concrete structures currently in use, and allows for the detection of problems in their early stages. This can be advantageous, especially from a financial perspective, because when a problem is detected at an early stage necessary interventions can be undertaken before the structure is completely damaged.

1.2 Problem Statement

The Kentucky Transportation Cabinet's (KYTC) current practice for determining the compressive strength of structural concrete consists of two methods. For newly placed concrete, test cylinders are prepared on-site and later tested for their compressive strength. For existing concrete, cores are taken from the in-place concrete and tested to determine their compressive strength. Both practices require the delivery of samples to an off-site facility for testing. As such, the affected parties on the project site must wait for the delivery of samples, the performance of tests and analysis of results, and the return of results to the project site. Analysis of existing structural concrete requires core samples to be taken from the structural element in question. This introduces a requirement to patch and repair sample locations and introduces the possibility of damaging an element's structural integrity. A quick, on-site method with minimal repair is needed to determine the compressive strength of concrete. The lateral pull off test, which has a similar principle and procedure as the pull off/pull out test, appears to be an accurate, non-destructive, and reliable procedure state transportation agencies can use to determine the compressive strength of concrete

in-place. This method also requires minimal patch work at sample locations. Samples are easily obtained and the test results are quickly determined on-site. However, there is gap between this method and current acceptable method of determining concrete compressive strength. To validate the accuracy and reliability of the lateral pull off test, data are needed to verify that information derived from it and the current acceptable method are similar. Additionally, specifications must be developed for KYTC to incorporate the lateral pull off test as an acceptable method of determining concrete compressive strength.

2. Objectives

The main objectives of this research study are:

1. Provide verification data that demonstrates the lateral dull off test and current acceptable method for determining concrete compressive strength produce similar results. Data are used to validate the lateral pull off test and show it is an acceptable and dependable method for determining concrete compressive strength.
2. Prepare and deliver specifications for the lateral pull off test so the Cabinet can use it routinely for determining concrete compressive strength.

3. Test Procedures

This research project involved laboratory tests and in-situ tests. The lateral pull off and compressive strength of cylinder tests on concrete slabs are run side by side in the laboratory. The lateral pull off test method is fully exercised. Cores taken from the concrete slab are tested in the laboratory. Results of the compressive strength of cylinder test are compared to those obtained from the lateral pull off test. Based on outputs from laboratory tests, test skill is fully developed. For this study, the lateral pull off test was run on concrete from bridges which are ready to be demolished. The compressive strength of cylinder was performed on cores taken from concrete bridges in-situ; it was run in the laboratory to compare with the results from lateral pull off test.

3.1 Laboratory Test

The first step of the laboratory test is to form the molds for concrete slabs. Three (3) concrete slabs with dimensions of 30.5" (width) x 46.5" (length) x 5.5" (depth) and twenty (20) 4" (diameter) x 8" (length) cast-in-place cylinder modal concrete samples are poured in the garage (Figure 1). A typical AA concrete mix design is used (Table 1). Testing for compressive strength of cylindrical concrete specimens follows ASTM C39/C39M – 14. Detailed procedures for this test are not reproduced here. Only details for lateral pull off test are elaborated in this report.



Figure 1 Three (3) concrete slabs with dimensions of 30.5" (width) x 46.5" (length) x 5.5" (depth) and twenty (20) 4" (diameter) x 8" (length) cast-in-place cylinder modal concrete samples are poured in the garage.

Table 1 A typical AA Concrete Mix Design (for a one cubic yard mix)

Material	Weight (lbs)	Percent
Water	260	6.6%
Cement	620	15.8%
Fine Aggregate	1204	30.7%
Coarse Aggregate	1838	46.9%
* 6% Air content by volumn		

3.1.1 Apparatus for Lateral Pull Off Test

The apparatus for the lateral pull off test requires three basic sub-systems: 1). a pullout insert, 2). a loading system, and 3). a load-measuring system. Additional equipment includes a core drill, a grinding wheel to prepare a flat bearing surface, a milling tool to undercut a groove to engage the insert, and an expansion tool to expand the insert into the groove. Commercial CAPO-TEST equipment was used for this study. It provides all the tools perform the appropriate functions.

3.1.2 Procedure for Lateral Pull Off Test

The procedure for lateral pull off test is as follows:

3.1.2.1 Install Inserts

The selected test surface shall be flat to provide a suitable working surface for drilling the core and undercutting the groove. Drill a core hole perpendicular to the surface to provide a reference point for later operations and to accommodate the expandable insert and associated hardware (Figures 2 and 3).

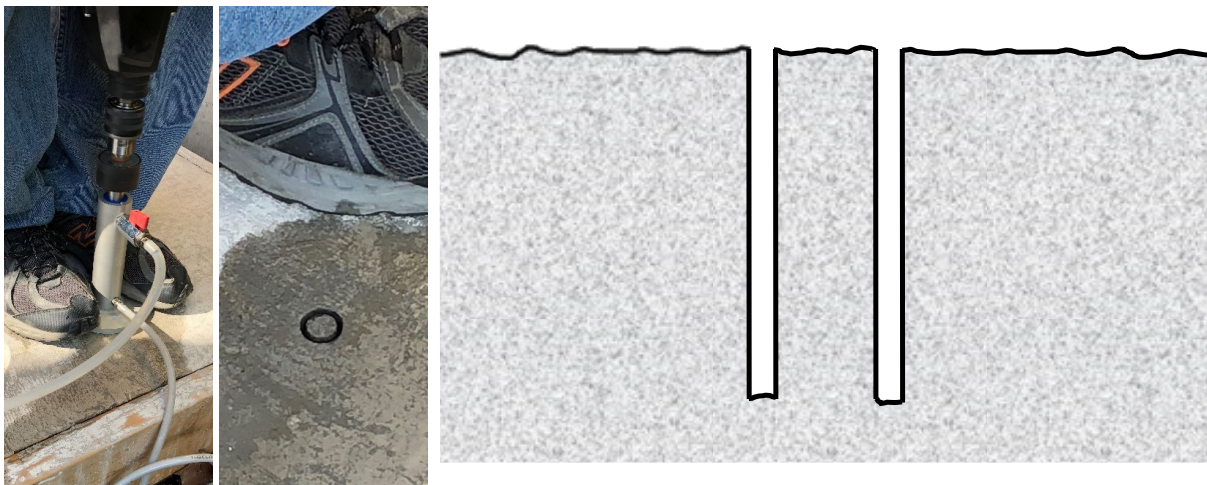

Figure 2 Coring with a water-cooled 0.72 in. diamond coring bit takes place to full 2.76 in. depth of the coring bit.



Figure 3 Remove core and ensure the hole is cleaned out.

Use a grinding wheel to prepare a flat surface so the base of the milling tool is supported firmly during test preparation and so the bearing ring is supported uniformly during testing. The ground surface shall be perpendicular to the axis of the core hole (Figures 4 and 5).

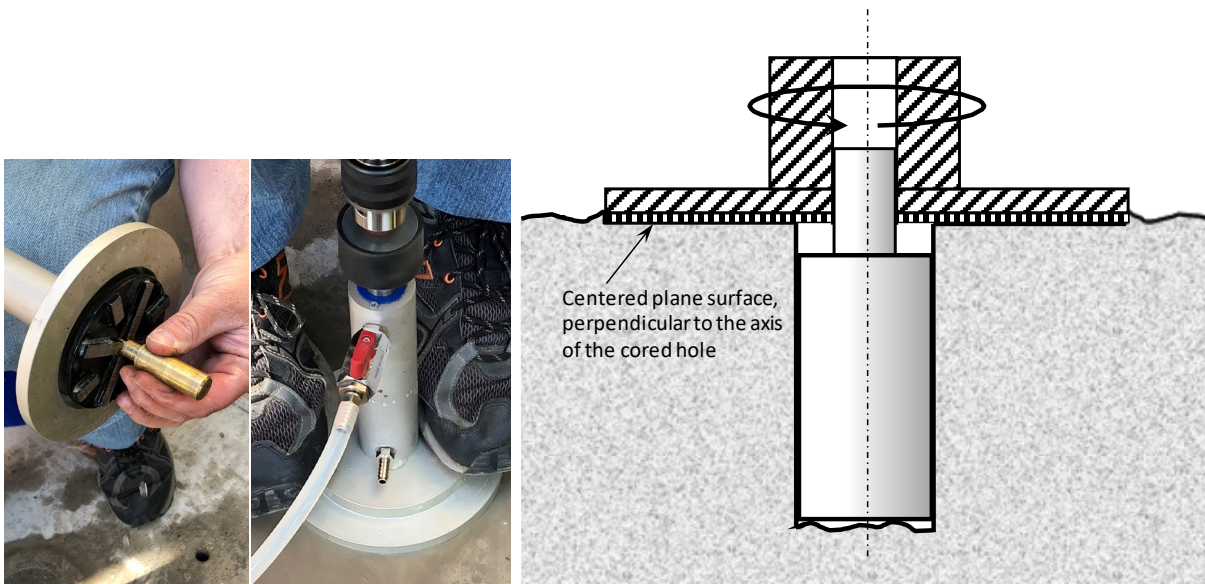

Figure 4 The centering brass rod is inserted in the hole and the diamond planning wheel is centered on the rod's top. Planning takes place with water cooled to a 1/10 in. depth by pressing the units axel connected to the drill machine against the surface, which has to be plane in its total circumference.



Figure 5 Surface ground.

Use the grinding tool to undercut a groove of the correct diameter at the correct depth in the core hole. The groove shall be concentric with the core hole (Figures 6 through 8).

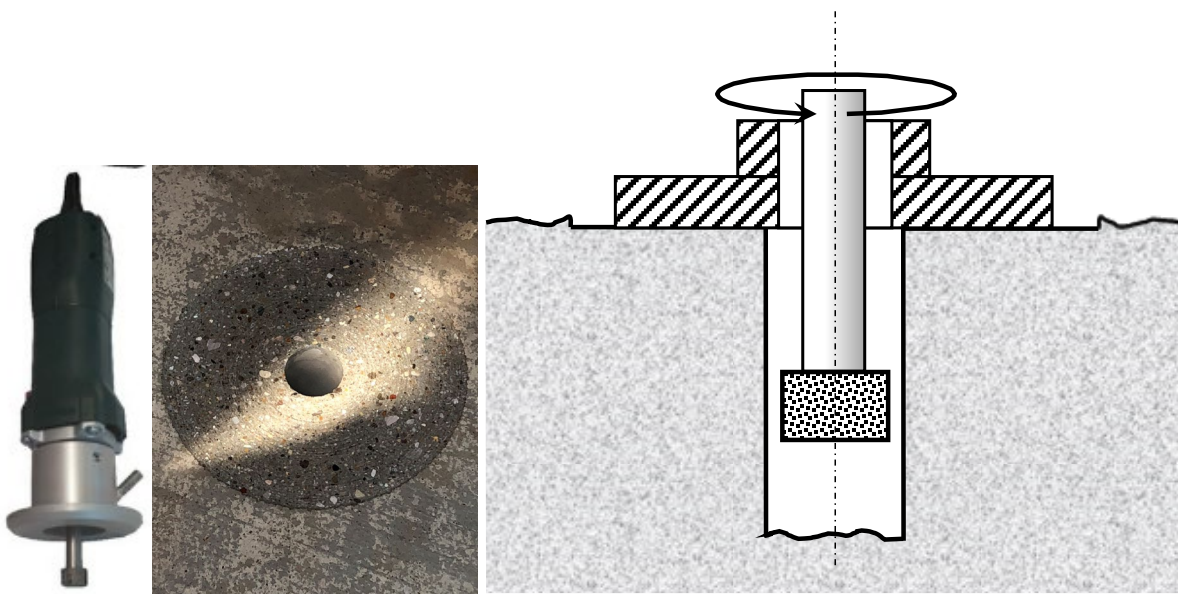

Figure 6 The diamond recess router is inserted in the drilled hole and turned on. The bit is water cooled. The flange of the recess router must rest firmly against the planed surface.

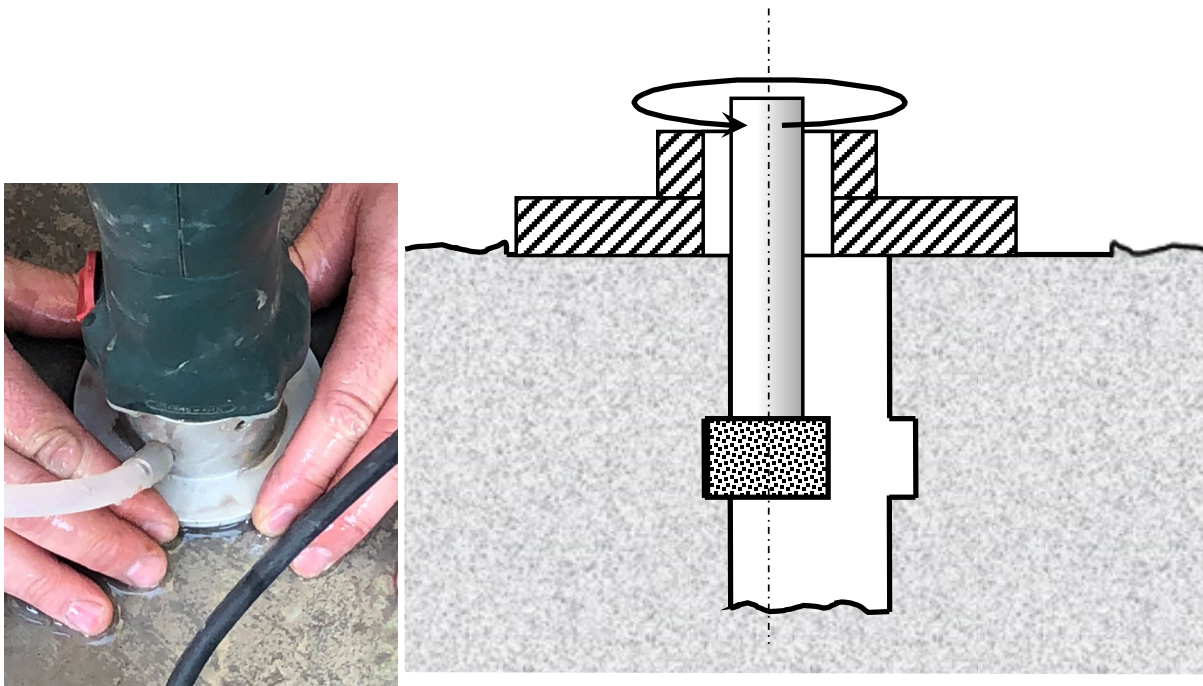

Figure 7 Recess routing is done by pressing the flange of the router against the planed surface and moving it sideways in progressively larger circles until the recess router shaft follows the side face of the cored 0.72 in. hole. The diameter of the recess must be 1.0 ± 0.01 in. after routing and the depth to the recess 1.0 in.

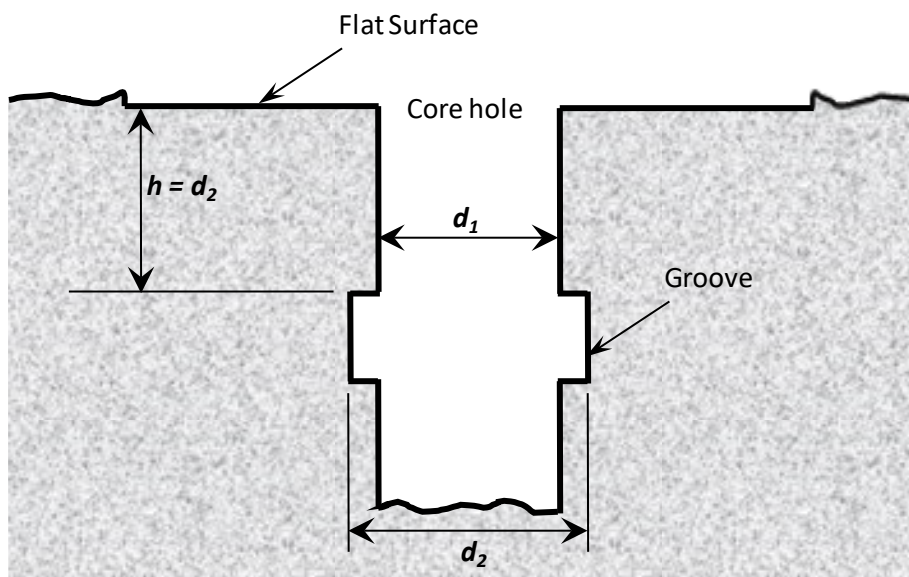

Figure 8 Hole with ground surface and undercut groove.

Remove freestanding water from the hole once drilling and undercutting are completed. Protect the hole from the ingress of additional water until the test is completed.

Use the expansion tool to position the expandable insert into the groove. Expand the insert to 1.0 ± 0.01 in. at 1.0 ± 0.01 in. depth (Figures 9 and 10). The expandable insert is shown in Figure 11. The expanded insert in the pictures is taken after test.

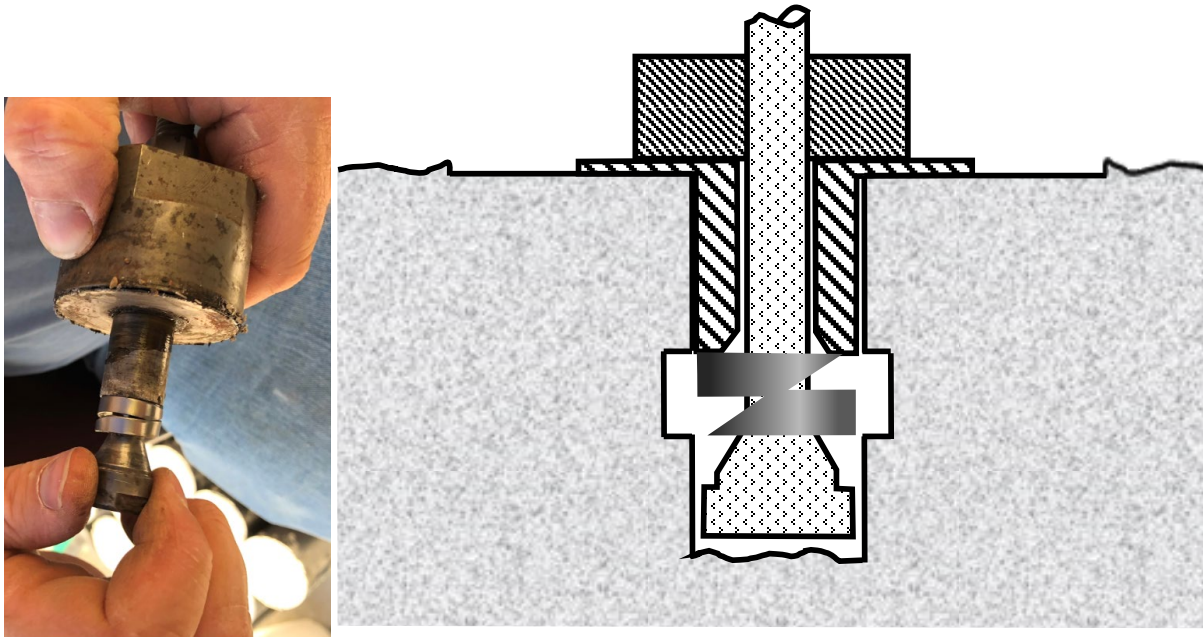

Figure 8 The assembled expansion tool with installed expandable ring is inserted in the hole.

3.1.2.2 Place Bearing Ring and Connect Pullout Parts

Place the bearing ring around the pullout insert shaft (Figure 12b), connect the pullout shaft to the hydraulic ram, and tighten the pullout assembly snugly against the bearing surface, checking to see that the bearing ring is centered around the shaft and flush against the concrete (*c* and *d* of Figure 12).

3.1.2.3 Pullout at Uniform Loading Rate

Apply load at a uniform rate (Figure 12e) so that the nominal normal stress on the assumed conical fracture surface increases at a rate of 10 ± 4 psi/s (70 ± 30 kPa/s). If testing the insert to rupture of the concrete, load at the specified uniform rate until rupture occurs. Record the maximum gauge reading to the nearest 112 lbf (0.5 kN) for analog gauges and to the nearest 22 lbf (0.1 kN) for digital gauges. If testing the insert only to a specified level for acceptance, load at the specified uniform rate until the specified pullout load is reached. Maintain the specified load for at least 10 seconds. For the pullout test system used in this project, in which $d_2 = 1.0$ in. (25 mm) and $d_3 =$

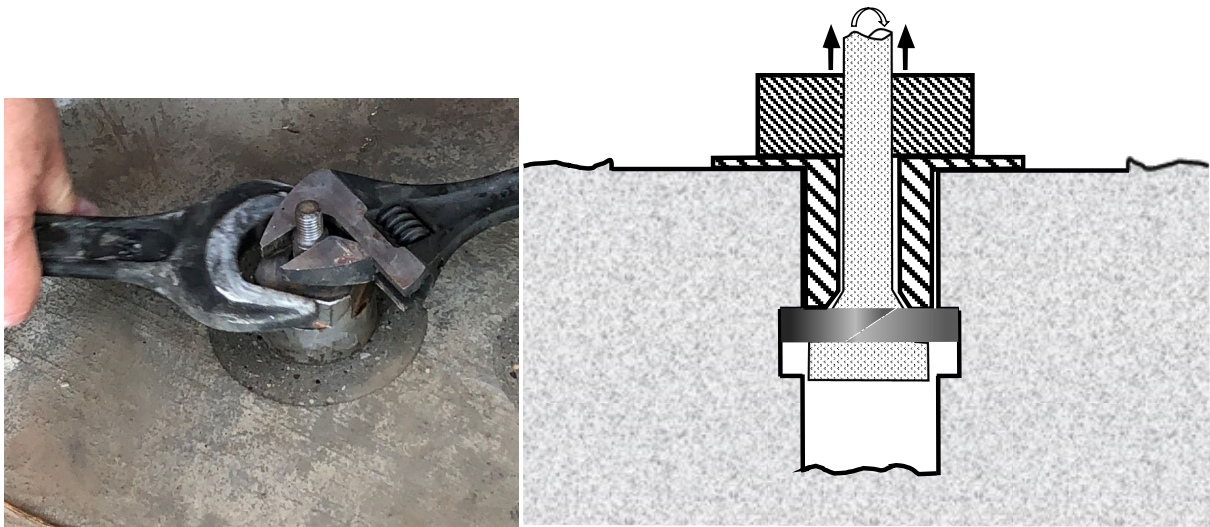

Figure 10 The expansion of the expandable ring is done by turning the big nut to the fully expanded position of the ring while keeping the center pull bolt in the same position.

2.2 in. (55 mm), (see Figure 8), the specified stress rate corresponds to a loading rate of approximately 112 ± 45 lbf/s (0.5 ± 0.2 kN/s).



Figure 9 The expandable insert expanded before and after. The left insert in both pictures is the shape before expansion; the right one in both pictures is the shape after expansion.

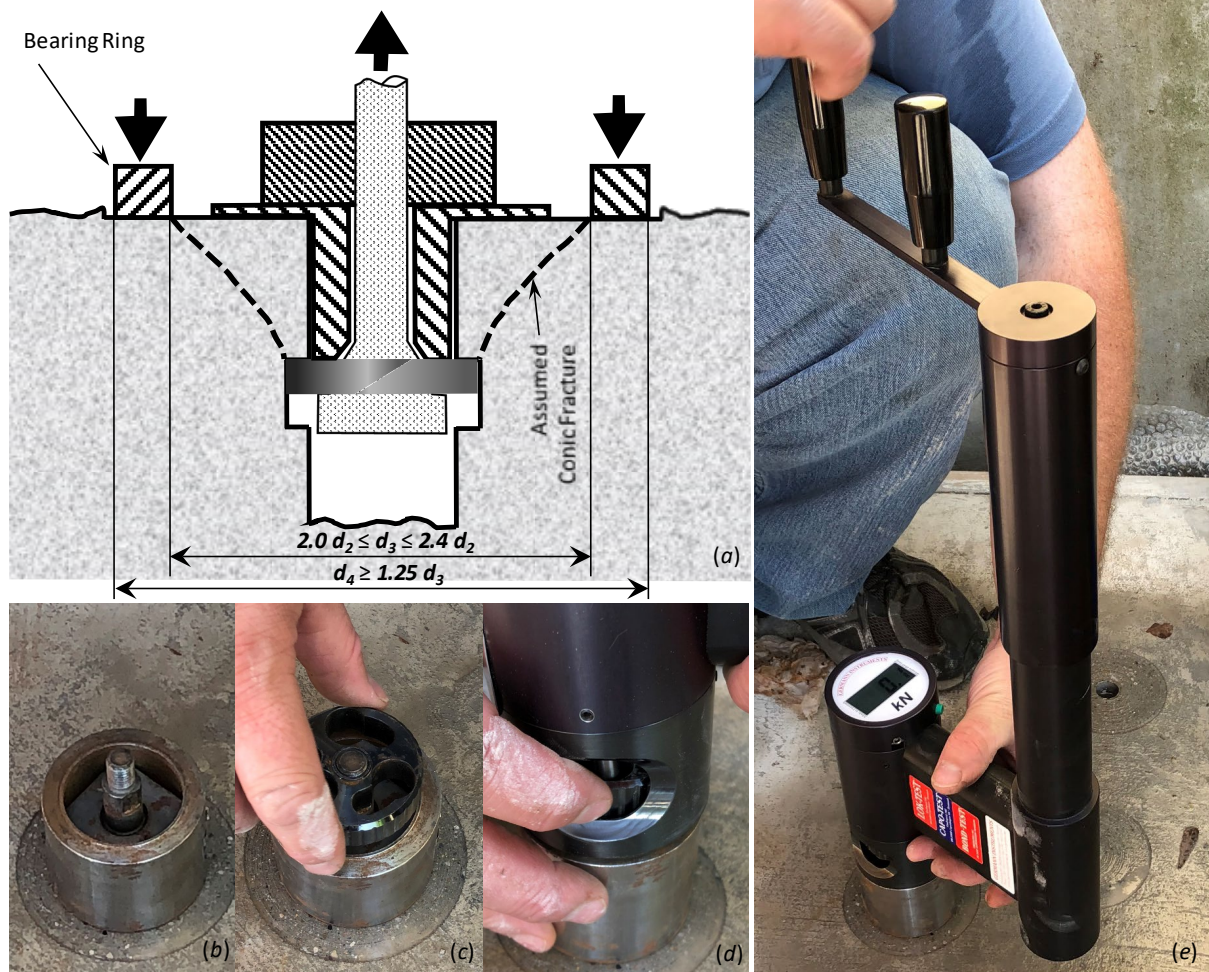

Figure 11 After fully expanding the expandable ring in the routed recess the counter pressure is installed on the surface and the coupling threaded to the center pull bolt. The hydraulic CAPO-TEST instrument is coupled to the coupling and the slack removed between instrument and counter pressure. Loading is done by turning the instruments handle slowly.

3.1.2.4 Test Result Rejection

Reject a test result if one or more of the following conditions is encountered:

- (1) The large end of the conic frustum is not a complete circle of the same diameter as the inside diameter of the bearing ring;
 - (2) The distance from the surface to the insert head (h in Figure 8) is not equal to the insert diameter;
 - (3) The diameter of the groove in an in-place installed test is not equal to the design value;
 - (4) The expanded insert diameter in an in-place installed test is not equal to the design value;
- or,
- (5) A reinforcing bar is visible within the failure zone after the conic frustum is removed.

3.2 In-Situ Test

With assistance from Cabinet and district engineers, two concrete bridges were successfully tested by performing lateral pull off test in-situ and running the compressive strength of cylinder test in

the laboratory on the samples cored from same bridges. The bridge were: 1) KY-159 over Kincaid Creek, Pendleton County (constructed 1940), and 2) US-42 over McCool Creek, Carroll County (constructed 1984). Similar to the description of the laboratory test, detailed procedures for testing specimens using the compressive strength of cylindrical concrete are omitted. Only details for lateral pull off test are elaborated in this report.

3.2.1 Apparatus for In-Situ Test

Apart from the apparatus used in laboratory tests, a Pachometer or a Ground Penetrating Radar (GPR) system is used for detecting reinforcement position on site. A GPR system was used for this research.

3.2.2 Procedure for In-Situ Lateral Pull Off Test

The procedure for in-situ lateral pull off test is as follows:

3.2.2.1 Detect Locations of Reinforcements

Locations of reinforcements on the bridge are detected using the GPR system. A lattice showing the steel reinforcement locations is drawn on bridge's surface (Figure 13). When running the lateral pull off test, care should be taken to avoid hitting steel reinforcements.

3.2.2.2 Run in-situ Lateral Pull Off Test

The rest of procedure to perform the in-situ lateral pull off test is identical to what is described in Sections 3.1.2.1 through 3.1.2.4.

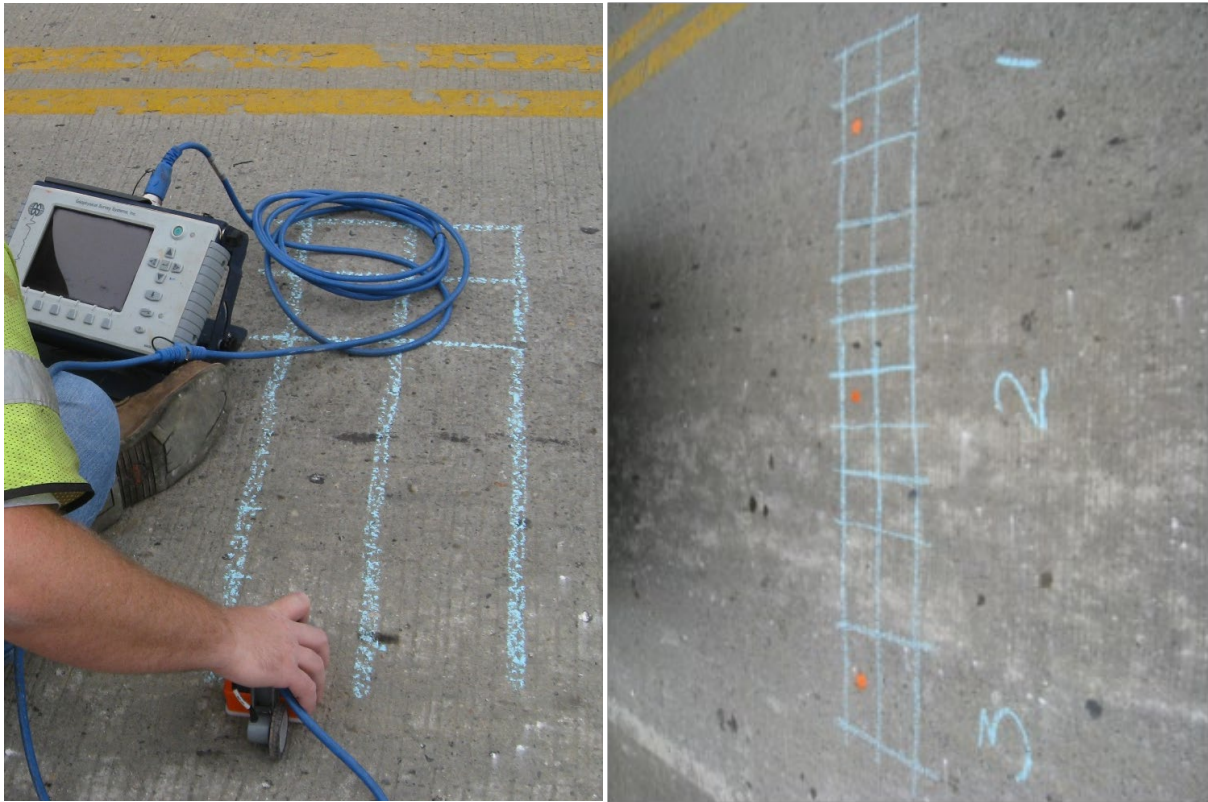

Figure 12 Detect and draw the locations of reinforcement.

4. Test Results and Discussion

Table 2 compares the test results for both the lateral pull off and compressive strength cylindrical concrete tests. The coefficient of variation (CV), which is a statistical measure of the dispersion of data points in a data series around the mean and is calculated as (standard deviation) / (mean value), is listed for both tests.

Table 2 Summary of laboratory test results from lateral pull off and cylindrical concrete compressive strength

(1)	(2)	(3)	(4)	(5)	(6)	(7)	(8)	(9)
Age of Samples (Days)	Core Strength (ksi)	Cylinder Modal Strength (ksi)	Average (ksi)	Coefficient of Variation (CV, %)	Lateral Pull Off Strength (ksi)	Average (ksi)	Coefficient of Variation (CV, %)	Strength Diff. btw Two Methods (%)
74		4.388			4.208			
		4.572			4.317			
		4.792	4.584	4.416	4.441			
					4.653			
					4.774	4.479	5.218	2.359
95	4.556				4.826			
	5.140				4.618			
	5.082				4.722			
	5.142				4.982			
	4.962				5.364			
	5.063		4.991	4.471	4.913	4.904	5.308	1.768
620	5.363				5.052			
	5.494				5.086			
	5.417				4.548			
	4.758				4.405			
	4.721				5.243			
	4.691				5.139			
	4.615				5.069			
	5.418				5.243			
	5.018		5.055	7.264	5.017	4.978	5.970	1.549
		4.525						
		5.726						
		5.055	5.102	11.788		4.978	5.970	2.488
Average CV (%)				6.985			5.498	

4.1 Laboratory Test Results

Table 2 summarizes the results for core strengths and lateral pull off test strength from the laboratory tests. To present all data for the different Age of Samples in a compact format, in Table 2, Columns 2, 3 and 6 provide individual test results for different tests or samples; Column 4 indicates the average core strength in ksi (average of 3 to 9 cores or cylinders by different Age of Samples); Column 5 contains the coefficient of variation (CV) of core strengths; the average pull off strength, in ksi, from the lateral pull off test (average of 5 to 9 tests by different Age of Samples) and the CV of the pull off strength are shown in Columns 7 and 8, respectively. The average CV of the core strengths is 6.985% and the average CV of the lateral pull off test pullout forces is 5.498%.

The average strengths from the compressive test and lateral pull off test indicate a positive correlation between the Age of Samples and concrete compressive strength. Average strengths from the compressive strength cylindrical concrete test are always higher than those obtained from the lateral pull off test. The average strength differences between test results from two different test methods are displaced in column 9. The largest difference of average strengths from the compressive strength cylindrical concrete test is 2.488% greater than those obtained from the lateral pull off test. This small bias is believed to be of no practical significance for the purpose of strength evaluation of concrete.

4.2 In-Situ Test Results

Table 3 summarizes the in-situ test results from the lateral pull off and cylindrical concrete compressive strength tests at two bridge sites. A large dispersal in values for core strengths are

Table 3 Summary of in-situ test results from lateral pull off and cylindrical concrete compressive strength

(1)	(2)	(3)	(4)	(5)	(6)	(7)	(8)
Location	Core Strength (ksi)	Average (ksi)	Coefficient of Variation (CV)	Lateral Pull Off Strength (ksi)	Average (ksi)	Coefficient of Variation (CV)	Strength Diff. btw Two Methods (%)
KY-159 over Kincaid Creek, Pendleton County	11.884			6.834			
	7.621			9.048			
	13.405	10.970	27.331	7.459	7.780	14.671	40.997
US-42 over McCool Creek, Carrol County	6.384			6.637			
	6.964			6.229			
	6.361	6.570	5.201	5.934			
				6.854			
				6.491	6.429	5.569	2.193



Figure 13 Sample from Pendleton County shown inhomogeneous and very poor gradation

observed for test results from the bridge on KY-159 over Kincaid Creek, Pendleton County. The CV of 27.331% indicates the standard deviation of these results reaches 27.331% of the average value of test results. Comparing with test results for core strength, results from the lateral pull off test are less dispersed. But the CV for these results is still 14.671%. The difference between these two average results is 40.997% (10.970 ksi vs 7.780 ksi). Figure 14 depicts the core sample after the break down test. Two issues are apparent in this image: (1) inhomogeneous and very poor gradation in concrete aggregates; (2) the gradation in the top one fifth of the sample differs from the gradation in rest of sample. This signifies either the top layer was added after the bottom bridge deck had been poured, or the top layer was a patch layer added in at some point after the original construction in 1940. Results off the lateral pull off test only pertain to the property of the top one fifth of bridge deck.

On the other hand, test results from the bridge on US-42 over McCool Creek, Carroll County, are more acceptable. The CVs of both test results are 5.201% for the core sample test and 5.569% for lateral pull off test. The average strength (6.429 ksi) from the lateral pull off test is 2.193% less than the value (6.570 ksi) from core sample test. This is similar to the difference in results obtained from laboratory testing.

5. Conclusions and Future Works

For this project, two series of tests — a laboratory test on freshly poured concrete slabs and an in-situ test on ready-to-demolish old bridges — were carried out. Both series of tests run the compressive strength cylindrical concrete test and lateral pull off test simultaneously to validate the lateral pull off test as an acceptable and dependable method for determining concrete compressive strength. The largest difference of average strengths from the compressive strength cylindrical concrete test is 2.488% greater than those obtained from the lateral pull off test. This small bias is believed to be of no practical significance for the purpose of strength evaluation of concrete. The test procedure and results look very promising based on the project's objective.

Based on the analysis presented in this report, KTC researchers have reached the following conclusions:

- (1) The lateral pull off test is a viable complement of the compressive strength cylindrical test for testing cores, provided the concrete in the 1 in. (25 mm) cover layer is representative of the interior concrete. This opens up the possibility of testing existing concrete structures with the lateral pull off test at a much higher testing frequency than is possible using cores alone. Compared with core testing, the lateral pull off test is less expensive, test results are obtained immediately, and there is little damage inflicted on the structure needing repair. It is recommended, however, that a limited number of cores always be taken to confirm that the correlation being used is applicable to the concrete in the structure.
- (2) The lateral pull off test is a viable option if the concrete grading is good and the maximum aggregate size 1.25 in. (32 mm). It is important to scrutinize the uniformity of the aggregate grading and the maximum aggregate size on the tested structure.
- (3) Usually, no large aggregates are present in the 1 in. (25 mm) cover, but if they are, the lateral pull off test performed through a large, hard aggregate, will give a high strength relative to a concrete with no large aggregates (as the test results for the KY-159 bridge over Kincaid Creek, Pendleton County, indicate).

With respect to implementation, the test device can be transferred to KYTC for future use. KTC researchers are also ready to assist with further activities at the request of the Cabinet, such as:

- (1) Test demonstration and/or a video of a test demonstration to optimize implementation.
- (2) Test demonstration on a pilot project to help bridge the gap between research and implementation.

The second option would give KTC the opportunity to promote the test method in practice.

References

- ACI228.1R-03, "In-Place Methods to Estimate Concrete Strength," *American Concrete Institute*, Farmington Hills, MI, www.concrete.org, 44 pp.
- ASTM Standard C39/C39M, 2014, "Compressive Strength of Cylindrical Concrete Specimens," *ASTM International*, 100 Barr Harbor Drive, West Conshohocken, PA, 2014.
- ASTM Standard C900, 2015, "Standard Test Method for Pullout Strength of Hardened Concrete," *ASTM International*, 100 Barr Harbor Drive, West Conshohocken, PA, 2015.
- Bickley, J. A., "The Variability of Pullout Tests and In-Place Concrete Strength," *Concrete International, American Concrete Institute*, Vol 4, No. 4, April 1982, pp. 44–51.
- Bickley, J. A., "The Evaluation and Acceptance of Concrete Quality by In-Place Testing," *In Situ/Nondestructive Testing of Concrete*, American Concrete Institute, 1984, pp. 95–109.
- Carrette, G. G., and Malhotra, V. M., "In Situ Tests: Variability and Strength Prediction of Concrete at Early Ages," *In Situ/Nondestructive Testing of Concrete*, American Concrete Institute, 1984, pp. 111–141.
- Carino, N.J., "Pullout Test," Chapter 3 in *Handbook on Nondestructive Testing of Concrete*, 2nd Edition, V.M. Malhotra and N.J. Carino, Eds., CRC Press, Boca Raton, FL, and ASTM International, West Conshohocken, PA, www.astm.org, 2004.
- Dilly, R. L., and Ledbetter, W. B., "Concrete Strength Based on Maturity and Pullout," *ASCE Journal of Structural Engineering, American Society of Civil Engineers*, Vol 110, No. 2, Feb. 1984, pp. 354–369.
- Hindo, K. R., and Bergstrom, W. R., "Statistical Evaluation of the In-Place Compressive Strength of Concrete," *Concrete International, American Concrete Institute*, Vol 7, No. 2, Feb. 1985, pp. 44–48.
- Khoo, L. M., "Pullout Technique—An Additional Tool for In Situ Concrete Strength Determination," *In Situ/Nondestructive Testing of Concrete, American Concrete Institute*, 1984, pp. 143–159.
- Malhotra, V. M., and Carrette, G., "Comparison of Pullout Strength of Concrete with Compressive Strength of Cylinders and Cores, Pulse Velocity and Rebound Number," *Journal, American Concrete Institute*, Vol 77, No. 3, May–June 1980, pp. 161–170.
- Parsons, T. J., and Naik, T. R., "Early Age Concrete Strength Determination Pullout Testing and Maturity," *In Situ/Nondestructive Testing of Concrete*, American Concrete Institute, 1984, pp. 177–199.

- Petersen, C.G., “LOK-TEST and CAPO-TEST Pullout Testing, Twenty Years Experience,” *Proceedings of Conference on Nondestructive Testing in Civil Engineering*, J.H. Bungey, Ed., British Institute of Nondestructive Testing, U.K., Liverpool, 8–11 April 1997, pp. 77–96.
- Richards, O., “Pullout Strength of Concrete,” *Reproducibility and Accuracy of Mechanical Tests*, ASTM STP 626, ASTM 1977, pp. 32–40.
- Soutsos, M.N., Bungey, J.H., and Long, A.E., “Pullout Test Correlations and In-Place Strength Assessment—The European Concrete Frame Building Project,” *ACI Materials Journal*, Vol 12, No. 6, Nov-Dec 2005, pp 422–428.
- Stone, W. C., and Giza, B. J., “The Effect of Geometry and Aggregate on the Reliability of the Pullout Test,” *Concrete International, American Concrete Institute*, Vol 7, No. 2, Feb. 1985, pp. 27–36.
- Vogt, W. L., Beizai, V., and Dilly, R. L., “In Situ Strength of Concrete with Inserts Embedded by ‘Finger Placing’,” *In Situ/Nondestructive Testing of Concrete*, American Concrete Institute, 1984, pp. 161–175.
- Yener, M., and Chen, W. F., “On In-Place Strength of Concrete and Pullout Tests,” *Cement, Concrete, and Aggregates, CCAGDP*, Vol 6, No. 2, Winter 1984, pp. 90–99.

Appendix A

Test Specification

IN-PLACE LATERAL PULL OFF TEST

The majority of information in this specification was taken from ASTM C 900 - 15, Standard Test Method for Pullout Strength of Hardened Concrete.

1. Scope:

- 1.1. This specification defines a test procedure for measuring the force required to pull an embedded metal insert and the attached concrete fragment from a concrete test specimen or structure. The insert is in-place installed in hardened concrete. (NOTE: The contents of this method are the responsibility of the Division of Construction. The Division of Materials is responsible for printing and distribution of this method.)
- 1.2. The values stated in Imperial units are to be regarded as the standard. SI units are included in parentheses as reference.
- 1.3. This specification does not purport to address all of the safety concerns, if any, associated with its use. It is the responsibility of the user of this specification to establish appropriate safety and health practices and determine the applicability of regulatory limitations prior to use.

2. Reference Documents

- 2.1. This specification complies with the following documentation:
 - ASTM Standard C 900 Standard Test Method for Pullout Strength of Hardened Concrete
 - ASTM Standard C125 Terminology Relating to Concrete and Concrete Aggregates
 - ASTM Standard C670 Practice for Preparing Precision and Bias Statements for Test Methods for Construction Materials
 - ASTM Standard E4 Practices for Force Verification of Testing Machines
 - ASTM Standard E74 Practice of Calibration of Force-Measuring Instruments for Verifying the Force Indication of Testing Machines
 - Kentucky Method 64-313-08

3. Summary of Test Method

- 3.1. A metal insert is in-place installed into hardened concrete. When an estimate of the in-place strength is desired, the insert is pulled by means of a jack reacting against a bearing ring. The pullout strength is determined by measuring the maximum force required to pull the insert from the concrete mass.

4. Significance and Use

- 4.1. For a given concrete and a given test apparatus, pullout strengths can be related to compressive strength test results. Such strength relationships depend on the configuration of the embedded insert, bearing ring dimensions, depth of embedment, and the type of aggregate (lightweight or normal weight). Prior to use, these relationships must be established for each system and each new combination of

concreting materials. Such relationships tend to be less variable where both pullout test specimens and compressive strength test specimens are of similar size, compacted to similar density, and cured under similar conditions.

- 4.2. If a strength relationship has been established experimentally and accepted by the specifier of tests, pullout tests are used to determine whether the in-place strength of concrete has reached a specified level so that, for example:
 - (1) post-tensioning may proceed;
 - (2) forms and shores may be removed;
 - (3) structure may be placed into service; or
 - (4) winter protection and curing may be terminated.

In addition, in-place installed pullout tests may be used to estimate the strength of concrete in existing constructions.

- 4.3. When planning pullout tests and analyzing test results, consideration should be given to the normally expected decrease of concrete strength with increasing height within a given concrete placement in a structural element. The measured pullout strength is indicative of the strength of concrete within the region represented by the conic frustum defined by the insert head and bearing ring. For typical surface installations, pullout strengths are indicative of the quality of the outer zone of concrete members and can be of benefit in evaluating the cover zone of reinforced concrete members.
- 4.4. In-place installed inserts can be placed at any desired location in the structure provided the requirements of following are satisfied: *Pullout test locations shall be separated so that the clear spacing between inserts is at least eight times the pullout insert head diameter. Clear spacing between the inserts and the edges of the concrete shall be at least four times the head diameter. Inserts shall be placed so that reinforcement is outside the expected conical failure surface by more than one bar diameter, or the maximum size of aggregate, whichever is greater.*

5. Apparatus

- 5.1. The apparatus requires three basic sub-systems: a pullout insert, a loading system, and a load-measuring system. Additional equipment includes a core drill, a grinding wheel to prepare a flat bearing surface, a milling tool to undercut a groove to engage the insert, and an expansion tool to expand the insert into the groove.
 - 5.1.1. In-place installed inserts shall be designed so that they will fit into the drilled holes, and can be expanded subsequently to fit into the grooves that are undercut at a predetermined depth (see Figure 1). A successful in-place installed system uses a split ring that is coiled to fit into the core hole and then expanded into the groove.

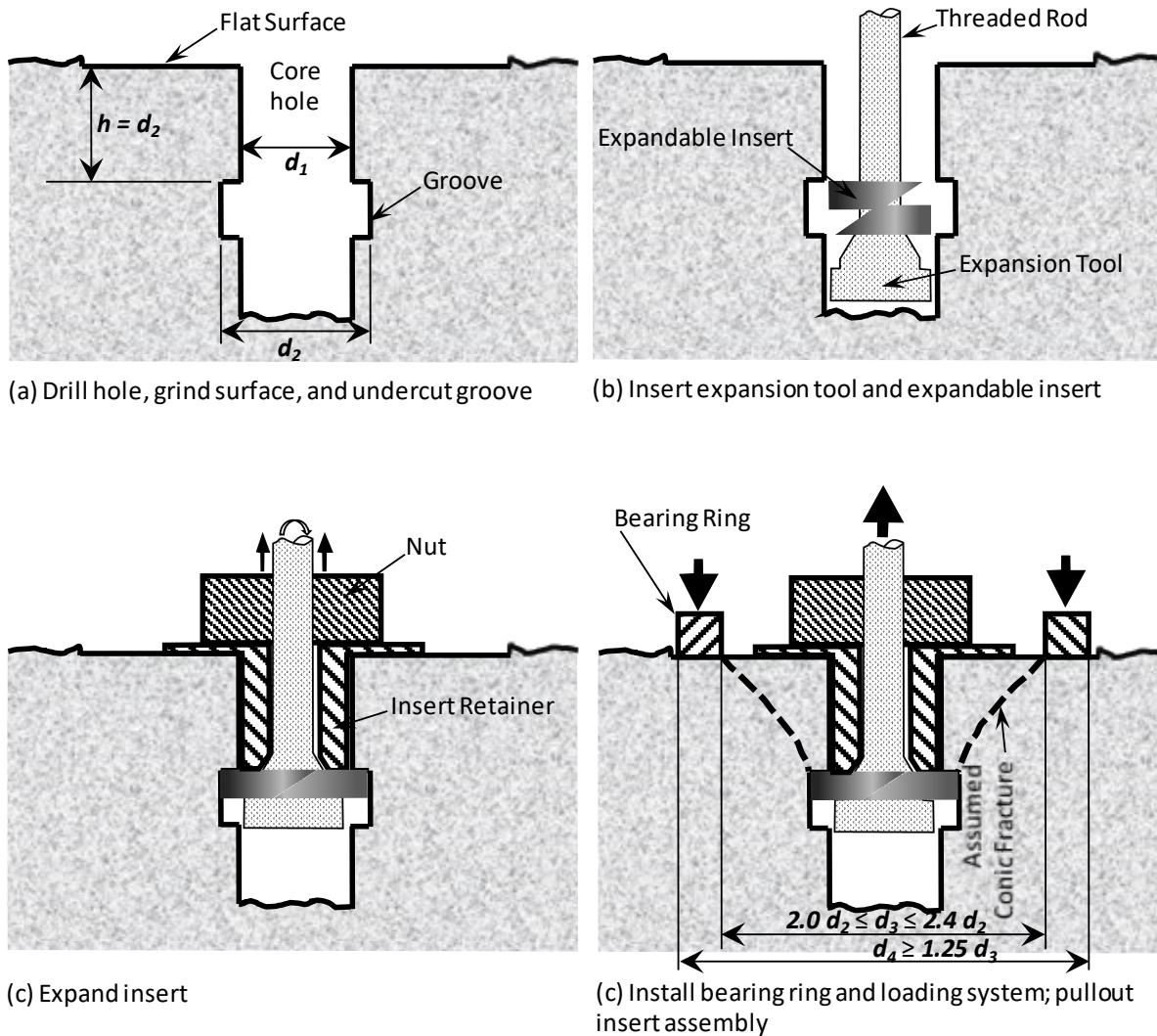

Figure 1. Schematic of Procedure for In-place Installed Pullout Test

- 5.1.2. The loading system shall consist of a bearing ring to be placed against the hardened concrete surface (see Figure 1) and a loading apparatus with the necessary load measuring devices that can be readily attached to the pullout shaft.
- 5.1.3. The test apparatus shall include centering features to ensure that the bearing ring is concentric with the insert, that the applied load is axial to the pullout shaft, perpendicular to the bearing ring, and uniform on the bearing ring.
- 5.2. Equipment dimensions shall be determined as follows (see Figure 1):
 - 5.2.1. The diameter of the insert head (d_2) is the basis for defining the test geometry. The thickness of the insert head and the yield strength of the metal shall be sufficient to avoid yielding of the insert during test. The insert head diameter shall be at least $\frac{2}{3}$ of the nominal maximum size of aggregate.

- 5.2.2. For in-place installed inserts, the groove to accept the expandable insert shall be cut so that the distance between the groove and concrete surface equals the insert diameter after expansion (d_2). The difference between the diameters of the undercut groove and the core hole (d_1) shall be sufficient to prevent localized failure and ensure that a conic frustum is extracted during the test. The expanded ring shall bear uniformly on the entire bearing area of the groove.
- 5.2.3. The bearing ring shall have an inside diameter (d_3) of 2.0 to 2.4 times the insert head diameter, and shall have an outside diameter (d_4) of at least 1.25 times the inside diameter. The thickness of the ring (t) shall be at least 0.4 times the pullout insert head diameter.
- 5.2.4. Tolerances for dimensions of the pullout test inserts, bearing ring and embedment depth shall be ± 2 % within a given system.
- 5.2.5. The loading apparatus shall have sufficient capacity to provide the uniform loading rate so that the nominal normal stress on the assumed conical fracture surface increases at a rate of 10 ± 4 psi/s (70 ± 30 kPa/s) and exceed the maximum load expected.
- 5.2.6. The gauge to measure pullout force is permitted to be of the analog or digital type. Analog gauges shall be designed so that the pullout force can be estimated to the nearest 112 lbf (0.5 kN). Digital gauges shall display the pullout force to the nearest 22 lbf (0.1 kN). For the most accurate results, gauges should have a maximum value indicator that preserves the value of the ultimate load when ultimate failure and subsequent stress release occur.
- 5.2.7. The pullout apparatus shall be calibrated in accordance with Annex A1 as defined in ASTM C900-15 at least once a year and after all repairs. Calibrate the pullout apparatus using a testing machine verified in accordance with Practices E 4 or a Class A load cell as defined in Practice E 74. The indicated pullout force based on the calibration relationship shall be within ± 2 % of the force measured by the testing machine or load cell.

6. Sampling

- 6.1. Pullout test locations shall be separated so that the clear spacing between inserts is at least eight times the pullout insert head diameter. Clear spacing between the inserts and the edges of the concrete shall be at least four times the head diameter. Inserts shall be placed so that reinforcement is outside the expected conical failure surface by more than one bar diameter, or the maximum size of aggregate, whichever is greater. A reinforcement locator is recommended to assist in avoiding reinforcement when preparing in-place installed tests (Kentucky Method 64-313-08). Follow the manufacturer's instructions for proper operation of such devices.
- 6.2. When pullout test results are used to assess the in-place strength in order to allow the start of critical construction operations, such as formwork removal or application of post tensioning, at least five individual pullout tests shall be performed as follows:
 - 6.2.1. For a given placement, every 150 yd³ (115 m³), or a fraction thereof, or

- 6.2.2. For slabs or walls, every 560 yd² (47 m²), or a fraction thereof, of the surface area of one face.
- 6.2.3. Inserts shall be located in those portions of the structure that are critical in terms of exposure conditions and structural requirements.
- 6.3. When pullout tests are used for other purposes, the number of tests shall be determined by the specifier.

7. Procedure

7.1. In-place Installed Inserts:

- 7.1.1. The selected test surface shall be flat to provide a suitable working surface for drilling the core and undercutting the groove. Drill a core hole perpendicular to the surface to provide a reference point for subsequent operations and to accommodate the expandable insert and associated hardware. The use of an impact drill is not permitted.
 - 7.1.2. If necessary, use a grinding wheel to prepare a flat surface so that the base of the milling tool is supported firmly during test preparation and so that the bearing ring is supported uniformly during testing. The ground surface shall be perpendicular to the axis of the core hole.
 - 7.1.3. Use the grinding tool in accordance with the manufacturer's instructions to undercut a groove of the correct diameter and at the correct depth in the core hole. The groove shall be concentric with the core hole.
 - 7.1.4. If water is used as a coolant, remove freestanding water from the hole at the completion of the drilling and undercutting operations. Protect the hole from ingress of additional water until the completion of the test.
 - 7.1.5. Use the expansion tool to position the expandable insert into the groove and expand the insert to its proper size in accordance with the manufacturer's instructions.
- 7.2. Bearing Ring—Place the bearing ring around the pullout insert shaft, connect the pullout shaft to the hydraulic ram, and tighten the pullout assembly snugly against the bearing surface, checking to see that the bearing ring is centered around the shaft and flush against the concrete.
- 7.3. Loading Rate—Apply load at a uniform rate so that the nominal normal stress on the assumed conical fracture surface increases at a rate of 10 ± 4 psi/s (70 ± 30 kPa/s). If the insert is to be tested to rupture of the concrete, load at the specified uniform rate until rupture occurs. Record the maximum gauge reading to the nearest 112 lbf (0.5 kN) for analog gauges and to the nearest 22 lbf (0.1 kN) for digital gauges. If the insert is to be tested only to a specified level for acceptance, load at the specified uniform rate until the specified pullout load is reached. Maintain the specified load for at least 10 s. For a pullout test system in which $d_2 = 1.0$ in. (25 mm) and $d_3 = 2.2$ in. (55 mm), the specified stress rate corresponds to a loading rate of approximately 112 ± 45 lbf/s (0.5 ± 0.2 kN/s).
- 7.3.1. Do not test frozen concrete.

- 7.4. Rejection—Reject a test result if one or more of the following conditions are encountered:
- 7.4.1. The large end of the conic frustum is not a complete circle of the same diameter as the inside diameter of the bearing ring;
 - 7.4.2. The distance from the surface to the insert head (h in Figure 1) is not equal to the insert diameter;
 - 7.4.3. The diameter of the groove in an in-place installed test is not equal to the design value;
 - 7.4.4. The expanded insert diameter in an in-place installed test is not equal to the design value; or,
 - 7.4.5. A reinforcing bar is visible within the failure zone after the conic frustum is removed.

8. Calculation

- 8.1. Convert gage readings to pullout force on the basis of calibration data.
- 8.2. Compute the average and standard deviation of the pullout forces that represent tests of a given concrete placement.

9. Report

- 9.1. Report the following information:
 - 9.1.1. Dimension of the pullout insert and bearing ring (sketch or define dimensions),
 - 9.1.2. Identification by which the specific location of the pullout test can later be determined,
 - 9.1.3. Date and time when the pullout test was performed.
 - 9.1.4. For tests to failure, maximum pullout load of individual tests, average, and standard deviation, lbf (kN). For tests to a specified load, the pullout load applied in each test, lbf (kN).
 - 9.1.5. Description of any surface abnormalities beneath the reaction ring at the test location,
 - 9.1.6. Abnormalities in the ruptured specimen and in the loading cycle,
 - 9.1.7. Concrete curing methods used and moisture condition of the concrete at time of test, and
 - 9.1.8. Other information regarding unusual job conditions that may affect the pullout strength.

10. Precision and Bias

- 10.1. Single Operator Precision—Based on the data summarized by Peterson (1997) for in-place installed pullout tests with embedment of about 25 mm (1 in.), the average coefficient of variation for tests made on concrete with maximum aggregate of 3/4 in. (19 mm) by a single operator using the same test device is 8 %. Therefore, the range in individual test results, expressed as a percentage of the average, should not exceed the following:

Number of Test	Acceptable Range, (Percent of Average)
5	31 %
7	34 %
10	36 %

- If the range of tests results exceeds the acceptable range, further investigation should be carried out. Abnormal test results could be due to improper procedures or equipment malfunction. The user should investigate potential causes of outliers and disregard those test results for which reasons for the outlying results can be identified positively. If there are no obvious causes of the extreme values, it is probable that there are real differences in concrete strength at different test locations. These differences could be due to variations in mixture proportions, degree of consolidation, or curing conditions.
- 10.2. Multi-Operator Precision—Test data are not available to develop a multi-operator precision statement.
- 10.3. Bias—The bias of this test method cannot be evaluated since pullout strength can only be determined in terms of this test method.

REFERENCES

Petersen, C.G., “LOK-TEST and CAPO-TEST Pullout Testing, Twenty Years Experience,” *Proceedings of Conference on Nondestructive Testing in Civil Engineering*, J.H. Bungey, Ed., British Institute of Nondestructive Testing, U.K., Liverpool, 8–11 April 1997, pp. 77–96.