



Evaluation of a provenance trial of *Acacia tortilis* at Khor Donia, Sudan

Trial no. 26 in the arid zone series

Ræbild, Anders; Graudal, Lars Ole Visti

Publication date:
2004

Document version
Publisher's PDF, also known as Version of record

Citation for published version (APA):
Ræbild, A., & Graudal, L. O. V. (2004). *Evaluation of a provenance trial of Acacia tortilis at Khor Donia, Sudan: Trial no. 26 in the arid zone series*. Danida Forest Seed Centre. Results and Documentation, No. 30

Evaluation of a provenance trial of *Acacia tortilis* at Khor Donia, Sudan

Trial no. 26 in the arid zone series

by

Anders Ræbild¹ and Lars Graudal¹

Forest Research Centre /Agricultural Research Corporation, Sudan

Food and Agriculture Organization, Rome

Danida Forest Seed Centre¹, Denmark

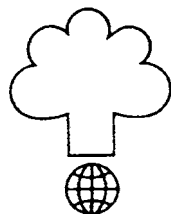

Results and Documentation no. 30

Danida Forest Seed Centre

2004

Citation:

A. Ræbild and Lars Graudal. 2004. Evaluation of a provenance trial of *Acacia tortilis* at Khor Donia, Sudan. Trial no. 26 in the arid zone series. Results and Documentation No. 30. Danida Forest Seed Centre, Humlebaek, Denmark.

Reproduction is allowed with citation

ISSN 0902-3224

Cover photo: View of the trial area at Khor Donia (above). Village nearby (below). Phot. Holger E. Nielsen 1994.

This publication can be requested from:

Forest & Landscape Denmark

Hørsholm Kongevej 11, DK-2970 Hørsholm, Denmark

Phone: +45-35281503 Fax: +45-35281517

Email: sl@kvl.dk

Web Site: www.SL.kvl.dk

and/or be downloaded from the DFSC homepage:

www.dfsc.dk/publications/

Technical Editor: Melita Jørgensen

Print:

Toptryk A/S, Graasten

From 1st January 2004, Danida Forest Seed Centre (DFSC) is part of the Danish Centre for Forest, Landscape and Planning, which is an independent centre under the Royal Veterinary and Agricultural University (KVL), in short *Forest & Landscape Denmark*.

Forest & Landscape is a merger between DFSC, the Danish Forestry College, the Danish Forest and Landscape Research Institute and the Department of Economics and Natural Resources at the Royal Veterinary and Agricultural University of Copenhagen (KVL).

Results and documentations are publications of analyses of e.g. provenance trials, carried out between DFSC and other institutions. DFSC publications are distributed free of charge.

Danida Forest Seed Centre (DFSC) is a Danish non-profit institute which has been working with development and transfer of know-how in management of tree genetic resources since 1969. The development objective of DFSC is to contribute to improve the benefits of growing trees for the well-being of people in developing countries. DFSC's programme is financed by the Danish International Development Assistance (Danida).

Preface

This report belongs to a series of analysis reports originally published by the Danida Forest Seed Centre. The series has served as a place for publication of trial results for the Centre itself as well as for our collaborators. With the integration of DFSC into the Danish Centre for Forest, Landscape and Planning, the series will be taken over by *Forest & Landscape* publication series.

The reports are available from the *Forest & Landscape* publication service and online from the web-site www.dfsc.dk. The scope of the series is in particular the large number of trials from which results have not been made available to the public, and which are not appropriate for publication in scientific journals. We believe that the results from these trials will contribute considerably to the knowledge on genetic variation of tree species in the tropics. Also, the analysis reports will allow a more detailed documentation than is possible in scientific journals.

This report presents results from a trial within the framework of the 'International Series of Trials of Arid and Semi-Arid Zone Arboreal Species', ini-

tiated by the FAO. Following collection and distribution of seed between 1983-87, a large number of trials were established by national institutions during 1984-1989. An international assessment of 26 trials took place from 1990 to 1994. DFSC was responsible for the reporting of this assessment.

This trial was established and maintained by the Forest Research Centre (FRC), Soba in collaboration with Agricultural Research Corporation (ARC), Gezira Research Station, Forestry Research Section, Medani in Sudan. The assessment team consisted of Kamal Hamad El Amin, El Amin Yosif A/Raddad, Mohamad Adam Burma, Farog Mohammed Ahmed, Adb El Bagi El Shami, Ramadan El Nour (FRC/ARC), Agnete Thomsen (FAO) and Holger Nielsen (DFSC).

The authors wish to acknowledge the help of the personnel at FRC/ARC with the establishment, maintenance and assessment of the trials, and thank the personnel of DFSC for their help with the data management and preliminary analyses. Drafts of the manuscript were commented on by Marcus Robbins, consultant to FAO.

Abstract

This report describes results from the analysis of a trial including five provenances of *Acacia tortilis* and one provenance of each of the species *A. albida*, *A. seyal* and *Prosopis chilensis*. The trial was established with a spacing of 3 x 3 metres in 1984 at Khor Donia in Sudan, and the assessment, which took place after 10 years in 1994, included a number of vegetative and growth characters. The provenances represented were from Israel, Senegal and Sudan.

On the average, survival in the trial was low. The provenance of *A. albida* and one of the provenances of *A. tortilis* had no surviving plants, and the rest of the provenances had survival ranging from 50 to 85 %. The differences between the rest of the provenances were less conspicuous and only on the limit of statistical significance. A multivariate test did not detect any differences between these provenances. When the provenances of *A. tortilis* were considered alone, no signs of statistical differences were found.

In terms of total basal area, the three best provenances were the provenances of *A. seyal* and *P. chilensis* together with a provenance of *A. tortilis* from Senegal. This provenance of *A. tortilis* had a production of biomass corresponding to 1.5 t ha⁻¹ y⁻¹.

Contents

Preface	i
Abstract	ii
Contents	iii
1. Introduction	1
2.. Materials and Methods	2
2.1 Site and establishment of the trial	2
2.2 Species and provenances	2
2.3 The experimental design	2
2.4 Assessment of the trial	2
3. Statistical analyses	3
3.1 Variables	3
3.2 Statistical model and estimates	3
4. Results	4
4.1 Survival	4
4.2 Height	6
4.4 Number of stems	7
4.5 Basal area of the mean tree	8
4.6 Total basal area	9
4.7 Dry weight of the mean tree	10
4.8 Total dry weight	12
4.9 Multivariate analysis	13
5. Discussion and conclusions	14
6. References	15
Annexes	
Annex 1. Description of the trial site	16
Annex 2. Seedlot numbers	17
Annex 3. Design of the trial	18
Annex 4. Plot data set	19
Annex 5. Graphical presentation of the health data	20

1. Introduction

This report describes the results from trial no. 26 in a large series of provenance trials within the 'International Series of Trials of Arid and Semi-Arid Zone Arboreal Species'. The main goals of the series were to contribute to the knowledge on the genetic variation of woody species, their adaptability and productivity and to give recommendations for the use of the species. The species included in this series of trials are mainly of the genera *Acacia* and *Prosopis*. A detailed introduction to the series is given by DFSC (Graudal *et al.* 2003)

The trial includes five provenances of *Acacia tortilis* and one provenance of each of the species *A. albida*, *A. seyal* and *Prosopis chilensis*. *A. tortilis* is widespread in the Sahel, East Africa and Arabia (Ross 1979, Brenan 1983, von Maydell 1986, Fagg & Barnes 1990), and the provenances in this trial are from Israel, Sudan and Senegal. At present four subspecies are recognised (Brenan 1983, Fagg & Barnes 1990), but in this trial only the subspecies *raddiana* and a provenance not yet classified is included. Provenances of the other species are from Senegal and Sudan, although the provenance of *P. chilensis* is a landrace (the species being introduced from South America).

2. Materials and Methods

2.1 Site and establishment of the trial

The trial is located at Khor Donia (12°22'N, 01°19'W) in Sudan at an altitude of 470 m. The mean annual temperature is approximately 28.1 °C, and the annual rainfall is 736 mm with a dry period of eight months. Seed was sown in the nursery in February 1984, and the trial was established in July 1984. Further site information is given in the assessment report (DFSC 1994) and summarised in annex 1.

2.2 Species and provenances

The provenances in the trial are presented in Table 1. As mentioned above the species included are *A. albida*, *A. seyal*, *A. tortilis* and *Prosopis chilensis* and represent a selection from Israel, Senegal and Sudan. Please note that *A. albida* according to newer literature is considered as belonging to a separate genus and thus is named *Faidherbia albida* (e.g. Fagg & Barnes 1990). For practical reasons we here use the terminology applied by the seed collectors. In Table 1 the provenances are given identification numbers relating to their geographical origin (name of province or country followed by a number). The original seedlot numbers are provided in annex 2.

2.3 The experimental design

The experimental design is a randomised complete block design with three blocks. In each block each provenance is represented by 9 trees in a plot, planted in a square of 3×3 trees. The trees are placed with a spacing of 3×3 m. The layout of the design is shown in annex 3, and further details are given in DFSC (1994).

2.4 Assessment of the trial

In February 1994 FRC/ARC, FAO and DFSC undertook a joint assessment. A detailed account of the assessment methods is given by DFSC (Graudal *et al.* 2003). The assessment included the following characters:

- Survival
- Health status
- Vertical height
- Diameter of the three largest stems at 0.05 and 0.3 m
- Number of stems at 0.3 m
- Crown diameter

Raw data from the assessment are documented in DFSC (1994). The plot data set on which the statistical analyses in this report are performed is shown in annex 4. This data set includes directly observed as well as derived values.

Table 1. Species and provenances tested in trial no. 26 at Khor Donia, Sudan. Data from seed suppliers except 1) from Pélissier (1983).

Provenance identification	Species	Seed collection site	Country of origin	Latitude	Longitude	Altitude (m)	Annual rainfall (mm)	No. of mother trees
Senegal08	<i>Acacia albida</i>	Bellokho	Senegal	15°20' N	16°21' W	38	600	30
Sudan13	<i>A. seyal</i>	Soba, Khartoum	Sudan	15°27' N	32°40' E	330	165	
Israel1	<i>A. tortilis</i>	Ein-Hazeva, Arava	Israel	30°47' N	35°12' W	100	40	
Senegal32	<i>A. tortilis</i> subsp. <i>raddiana</i>	Diengue-Dior	Senegal	15°20' N	16°20' W	38	600	
Senegal33	<i>A. tortilis</i> subsp. <i>raddiana</i>	Foret Classe Rao	Senegal	15°56' N	16°23' W	8	400 ¹	30
Senegal34	<i>A. tortilis</i> subsp. <i>raddiana</i>	Foret Classe Keur-Mbaye	Senegal	16°29' N	15°35' W	6	400 ¹	30
Sudan14	<i>A. tortilis</i> subsp. <i>raddiana</i>	Khartoum, West Of The Nile	Sudan	15°36' N	32°33' E	330	165	
Sudan25	<i>Prosopis chilensis</i>	Soba, Khartoum	Sudan	15°27' N	32°40' E	330	165	

3. Statistical analyses

3.1 Variables

In this report the following eight variables are analysed:

- Survival
- Vertical height
- Crown area
- Number of stems at 0.3 m
- Basal area of the mean tree at 0.3 m
- Total basal area at 0.3 m
- Dry weight of the mean tree
- Total dry weight

The values were analysed on a plot basis, i.e. ratio, mean or sum as appropriate. Survival was analysed as the rate of surviving trees to the total number of trees per plot. Height, crown area and number of stems were analysed as the mean of surviving trees on a plot, as were the basal area and the dry weight of the mean tree. The total basal area and the total dry weight represent the sum of all trees in a plot, expressed on an area basis. Note that the calculations of basal area are based on measurements of the three largest stems per tree.

A large proportion of the trees was damaged either by fire, water stress and attack from insects or by cutting off branches for firewood. However, as the initial graphical analysis gave no indications of provenance differences in susceptibility to damage, no statistical analysis of this character was performed. The interpretation of such analysis would have been difficult as the damage was due to several different causes. Instead a graphical presentation of the health scores is given in annex 5.

Due to illegal cutting, it was impossible to measure the diameter at 0.3 m for 14 of the 90 trees alive at the time of assessment. However, since trees were cut at some distance above the ground, it was possible to measure the diameter at 0.05 m. By comparing basal area at 0.05 m and 0.3 m for the trees that were not cut, it was possible to establish a regression between basal areas for the two heights and thus calculate the basal area at 0.3 m for the trees that were cut. The reason that the analysis of basal area is not performed for values that were measured at 0.05 m (which would be simpler) is to enable comparison with other trials in the arid zone series. The regressions are of the type

$$ba30 = a + b \times ba05$$

where *ba05* and *ba30* are the basal areas measured at 0.05 and 0.3 m respectively, and *a* and *b*

are constants specific for each provenance. The constants appear in Table 2. Since there were no surviving trees in the provenances Senegal08 and Senegal32, no constants are available for these trees.

Table 2. Constants used in the regression between basal area measured at 0.05 and 0.3 m.

Provenance	a	b
Sudan14	6.30	0.415
Sudan13	2.85	0.747
Sudan25	25.98	0.382
Israel1	-1.21	0.637
Senegal33	-3.48	0.749
Senegal34	0.83	0.702

Obviously it was not possible to measure height and crown area for felled trees, and these are therefore omitted from the analyses of these variables. Even for the trees where diameter was measured at 0.3 m, there were some which had no measurements of crown diameter (9 trees), number of stems and vertical height (3 and 4 trees), presumably because of cutting at a point higher than 0.3 m. No correction was made for this.

The dry weight values were calculated from regressions between biomass and basal area, established in another part of this study (Graudal et al., in prep.). For *A. tortilis* the regression is

$$TreeDW = e^{(2.294 \times \ln(basalarea) - 1.685)}$$

where *TreeDW* expresses the dry weight of the tree in kg tree⁻¹, and *basalarea* expresses the basal area (at 0.3 m) of the tree in cm².

No such regressions were available for *A. seyal* and *P. chilensis*.

3.2 Statistical model and estimates

For each variable, two tests were performed. The first test was a test of differences between all provenances, whereas the second tested only for differences between the provenances of *A. tortilis*. Since the provenances Senegal08 (*A. albidia*) and Senegal32 (*A. tortilis*) had a survival of zero, these were excluded from all analyses except for survival.

All tests were based on the model:

$$X_{ij} = \mu + provenance_i + block_j + \epsilon_{ij}$$

where *X_{ij}* is the value of the trait in plot *ij*, μ is the

grand mean, *provenance*_{*i*} is the fixed effect of provenance number *i*, *block*_{*j*} is the fixed effect of block *j*, and ϵ_{ij} is the residual of plot *ij* and is assumed to follow a normal distribution $N(0, \sigma_e^2)$.

To complement blocks in adjusting for uneven environments, co-variables related to the plot position were included. In the initial models, the co-variables were distances along the two axes of the trial, plotx and ploty, and squared values of these, plotx2 and ploty2. The co-variables were excluded successively if they were not significant at the 10% level.

Standard graphical methods and calculated standard statistics were applied to test model assumptions of independence, normality and variance homogeneity (Snedecor & Cochran 1980, Draper & Smith 1981, Ræbild et al. 2002). In one case it was necessary to exclude one observation to fulfil the basic model assumptions (ibid.; Afifi & Clark 1996).

The P-values from the tests of provenance differences were corrected for the effect of multiple comparisons by the sequential tablewise Bonferroni method (Holm 1979). First the tests were ranked according to their P values. The test cor-

responding to the smallest P value (P_1) was considered significant on a "table-wide" significance level of α if $P_1 < \alpha/n$, where *n* is the number of tests. The second smallest P value (P_2) was declared significant if $P_2 < \alpha/(n-1)$, and so on (c.f. Kjær & Siegismund 1996). The number of tests of differences between all provenances was six (dry weight variables were not included) and eight in the tests of differences between the provenances of *A. tortilis*. The significance levels are indicated by (*) (10%), * (5%), ** (1%), *** (1 ‰) and N.S. (not significant).

A multivariate analysis providing canonical variates, and Wilk's lambda and Pillai's trace statistics, complemented the univariate analyses (Chatfield & Collins 1980, Afifi & Clark 1996, Skovgård & Brockdorf 1998).

The statistical software package used was the Statistical Analysis System (SAS 1988a, 1988b, 1991, Littell et al. 1996). A more detailed description of the methods used for the analyses of variance is given in Ræbild et al. (2002), and a short description of the analysis of each variable is given in the result section.

4. Results

4.1 Survival

Survival is regarded as one of the key variables when analysing tree provenance trials, since it indicates the adaptability of the provenance to the environment at the trial site. It should be noted that survival reflects only the conditions experienced during the first years growth of the trial and not necessarily the climatic extremes and conditions that may be experienced during the life-span of a tree in the field.

Statistical analysis

In this analysis there were no problems with the distribution of the residuals. The co-variate ploty was significant in both analyses.

Results

Of the 209 trees planted, only 90 were alive at the time of assessment. Of these, 14 had been recently cut but were considered as being alive in the statistical calculations. Two provenances, Senegal08 of *A. albida* and Senegal32 of *A. tortilis* had no surviving plants. For the rest of the provenances, survival varied between 50 and 85 % (Fig. 1). The highest survival was found in the provenances Senegal33 and Sudan14, both *A. tortilis*.

The differences between provenances were highly significant when all provenances were included (Table 3), but when Senegal08 and Senegal32 were excluded, the provenance effect was no longer significant ($P=0.15$, not shown).

The same was the case in the analysis of *A. tortilis* differences. When all provenances were included, the provenance effect was significant, but significance disappeared if Senegal32 was not included ($P=0.10$, not shown).

Table 3. Results from analysis of variance of provenance differences of survival in trial 8.

Effect	DF	MS	F-value	P-value	Bonferroni sequential tablewise correction
Test of all provenances					
Provenance	7	0.28	14.0	<0.0001	***
Block	2	0.09	4.4	0.04	
Ploty	1	0.11	5.5	0.04	
Error	13	0.02			
Test of <i>A. tortilis</i> provenances					
Provenance	4	0.30	18.7	0.0008	**
Block	2	0.03	1.6	0.27	
Ploty	1	0.07	4.1	0.08	
Error	7	0.02			

Figure 1. Survival in the provenance trial at Khor Donia, Sudan (Trial no. 26 in the arid zone series). Values presented are least square means with 95 % confidence limits.

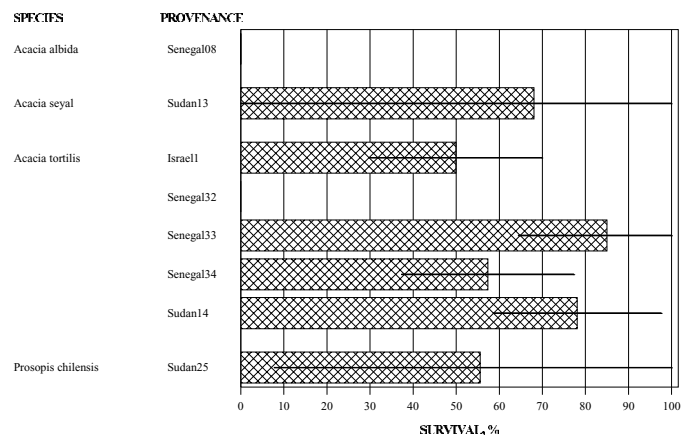

4.2 Height

Height is usually considered an important variable in the evaluation of species and provenances. However, this of course depends on the main uses of the trees. Apart from indicating productivity, height may also be seen as a measure of the adaptability of trees to the environment, tall provenances/trees usually being better adapted to the site than short provenances/trees. This interpretation need not always be true, as there have been cases where the tallest provenances are suddenly affected by stress with a subsequent die-off of the trees.

Statistical analysis

There were no complications in the statistical analyses, and no co-variates were significant.

Results

Sudan13 of *A. seyal* was the highest provenance with 4.8 m, followed by Sudan25 (*P. chilensis*) with 3.8 m. The surviving provenances of *A. tortilis* were surprisingly uniform with respect to height, all being 2.5-2.8 m. The provenance effect was at the border of significance when all provenances were included (Table 4), but when only *A. tortilis* was analysed, there was absolutely no sign of significant differences.

Table 4. Results from analysis of variance of provenance differences of height in trial 26.

Effect	DF	MS	F-value	P-value	Bonferroni sequential tablewise correction
Test of all provenances					
Provenance	5	2.6	5.4	0.01	*
Block	2	4.3	9.0	0.006	
Error	10	0.5			
Test of <i>A. tortilis</i> provenances					
Provenance	3	0.02	0.1	0.97	n.s.
Block	2	5.17	16.3	0.004	
Error	6	0.31			

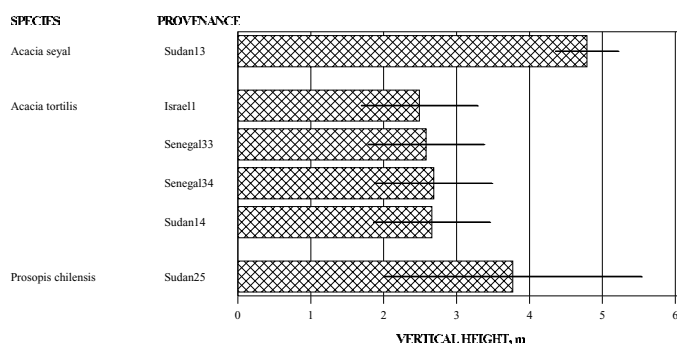

Figure 2. Vertical height in the provenance trial at Khor Donia, Sudan (Trial no. 26 in the arid zone series). Values presented are least square means with 95 % confidence limits.

4.3 Crown area

The crown area variable indicates the ability of the trees to cover the ground. The character is of importance in shading for agricultural crops, in evaluating the production of fodder and in protection of the soil against erosion.

Statistical analysis

Due to cutting, there were no measurements of crown area for 23 of the trees alive. One plot had a substantially larger value for crown area than the other plots (Senegal33 in block 1). When considering this plot closer, it appeared that there was only one tree left on the plot, which may justify taking the observation away, because trees without competition tend to develop large crowns. Data are presented without the outlier.

The co-variate ploty2 was significant in the test of differences between all provenances.

Results

Sudan25 (*P. chilensis*) had the highest crown area with 25 m² tree⁻¹, followed by Israel1 (*A. tortilis*) with 20 m² tree⁻¹ and Sudan13 (*A. seyal*) with 15 m² tree⁻¹. The three remaining provenances of *A. tortilis* all had crown areas below 10 m² tree⁻¹ (Fig. 3). The provenance differences were significant when all provenances were included, but again the differences were no longer significant when *A. tortilis* was analysed alone (Table 5).

Table 5. Results from analysis of variance of provenance differences of crown area in trial 26.

Effect	DF	MS	F-value	P-value	Bonferroni sequential tablewise correction
Test of all provenances					
Provenance	5	197	13.2	0.002	**
Block	2	44	3.0	0.12	
Ploty2	1	62	4.2	0.08	
Error	7	15			
Test of <i>A. tortilis</i> provenances					
Provenance	3	95	4.0	0.11	n.s.
Block	2	36	1.5	0.32	
Error	4	24			

Figure 3. Crown area in the provenance trial at Khor Donia, Sudan (Trial no. 26 in the arid zone series). Values presented are least square means with 95 % confidence limits.

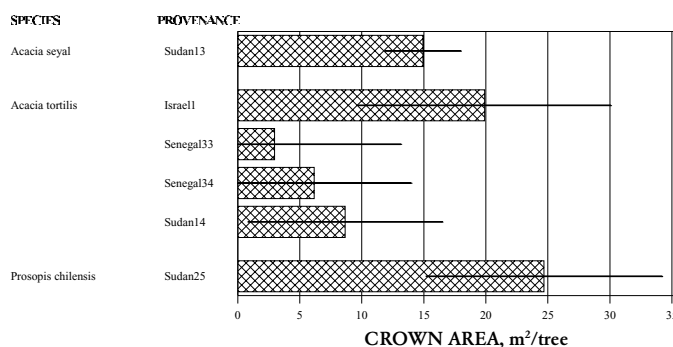

4.4 Number of stems

The number of stems gives an indication of the growth habit of the species. Trees with large number of stems are considered bushy, whereas trees with only one stem have a more tree-like growth.

Statistical analysis

For 17 of the trees alive, there were no records of the number of stems, and these trees are therefore excluded from the analyses. There were no problems with distribution of the residuals, and the un-transformed data were used for the model. The co-variate ploty was significant in the test of all provenances.

Results

A. seyal and *P. chilensis* were representing the extremes with regard to number of stems, having 1.2 and 2.2 stems tree⁻¹, respectively (Fig. 4). The provenances of *A. tortilis* were intermediate. The test of all provenances demonstrated that the provenances were significantly different, but when only *A. tortilis* provenances were tested, the significance disappeared (Table 6).

Table 6. Results from analysis of variance of provenance differences of number of stems in trial 26.

Effect	DF	MS	F-value	P-value	Bonferroni sequential table-wide correction
Test of all provenances					
Provenance	5	0.50	4.8	0.02	(*)
Block	2	0.31	2.9	0.10	
Ploty	1	0.59	5.6	0.04	
Error	9	0.10			
Test of <i>A. tortilis</i> provenances					
Provenance	3	0.06	0.5	0.70	n.s.
Block	2	0.22	1.7	0.26	
Error	6	0.13			

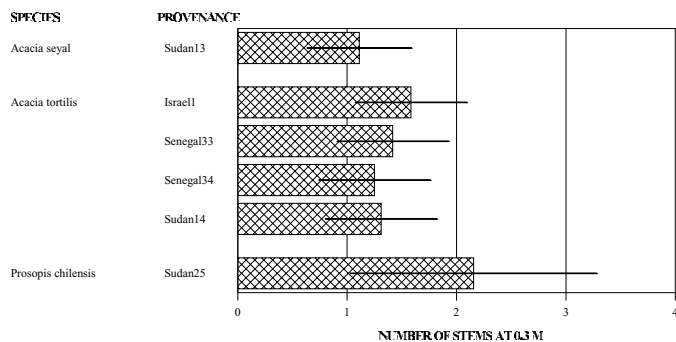

Figure 4. Number of stems in the *A. tortilis* provenance trial at Khor Donia, Sudan (Trial no. 26 in the arid zone series). Values presented are least square means with 95 % confidence limits.

4.5 Basal area of the mean tree

The basal area is often used as a measure of the productivity of stands, since it is correlated with the production of wood. The basal area of the mean tree is calculated on the live trees only and gives an indication of the potential basal area production of the provenance provided that all trees survive.

Statistical analysis

Note that due to cutting, the basal area for some trees had to be estimated (see 3.1). Apart from this, the analyses proceeded without problems. No co-variables were significant.

Results

The provenance Sudan25 (*P. chilensis*) took the lead with a basal area of the mean tree of 85 cm² tree⁻¹ (Fig. 5). Sudan13 (*A. seyal*) was next with 57 cm² tree⁻¹, followed by the provenances of *A. tortilis*, having mean basal areas of 40 cm² tree⁻¹ or below. The differences were balancing on the edge of significance when all provenances were included (Table 7). As regards the provenances of *A. tortilis* no significant differences were found.

Table 7. Results from analysis of variance of provenance differences of basal area of the mean tree in trial 26.

Effect	DF	MS	F-value	P-value	Bonferroni sequential tablewise correction
Test of all provenances					
Provenance	5	1207	3.2	0.06	(*)
Block	2	927	2.5	0.14	
Error	10	377			
Test of <i>A. tortilis</i> provenances					
Provenance	3	67	0.35	0.79	n.s.
Block	2	1886	9.8	0.01	
Error	4				

Figure 5. The basal area area of the mean tree in the *Acacia tortilis* provenance trial at Khor Donia, Sudan (Trial no. 26 in the arid zone series). Values presented are least square means with 95 % confidence limits.

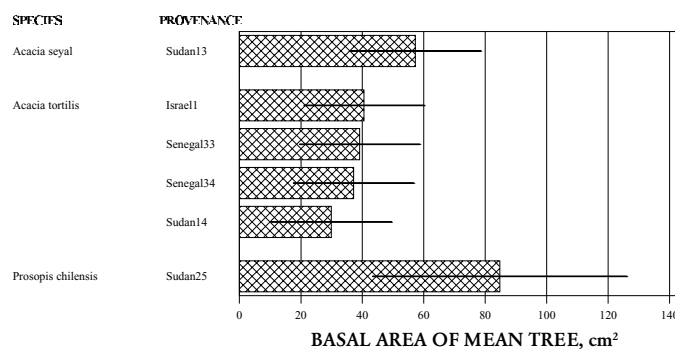

4.6 Total basal area

In comparison to the basal area of the mean tree, the total basal area accounts for missing trees and is thus a better measure of the actual production on the site.

Statistical analysis

The original, un-transformed model was applied for the analyses. Plotx2 and ploty were significant in both analyses.

Results

The total basal areas of the three largest provenances, Sudan13 (*A. seyal*), Senegal33 (*A. tortilis*) and Sudan25 (*P. chilensis*), were in the range of 4.4 to 5.1 m² ha⁻¹ (Fig. 6). Israel1 and Senegal34 had the lowest basal areas with only approximately 1 m² ha⁻¹, whereas the last provenance of *A. tortilis* (Sudan14) was intermediate. When all provenances were included, the differences were significant or, after the correction for multiple comparisons, almost significant (Table 8). For the *A. tortilis* provenances, the differences were also almost significant, but the Bonferroni test was not significant at all.

Table 8. Results from analysis of variance of provenance differences of total basal area in trial 26.

Effect	DF	MS	F-value	P-value	Bonferroni sequential tablewise correction
Test of all provenances					
Provenance	5	9.1	5.4	0.02	(*)
Block	2	13.8	8.3	0.01	
Plotx2	1	8.4	5.0	0.06	
Ploty	1	11.9	7.1	0.03	
Error	8	1.7			
Test of <i>A. tortilis</i> provenances					
Provenance	3	3.34	5.6	0.06	n.s.
Block	2	6.91	11.6	0.02	
Plotx2	1	4.14	6.9	0.06	
Ploty	1	2.93	4.9	0.09	
Error	4	0.60			

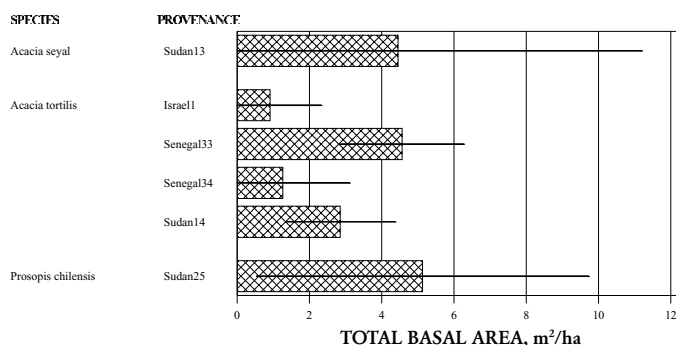

Figure 6. Total basal area in the provenance trial at Khor Donia, Sudan (Trial no. 26 in the arid zone series). Values presented are least square means with 95 % confidence limits.

4.7 Dry weight of the mean tree

The dry weight of the mean tree is comparable to the basal area of the mean tree in that they both are calculated on the live trees only and thus serve as a measure of the potential production at the site, provided that all trees survive. Furthermore, the two variables are linked closely as the basis for estimation of the dry weight is the basal area. However, an important difference is that the dry weight include a cubic term (in comparison to basal area having only a square term), meaning that large trees with a large dry mass are weighted heavily in this variable. The dry weight is thus the best estimate for the production of biomass at the site.

Statistical analysis

As there are no estimates for species other than *A. tortilis*, tests and results are given only for this species. Apart from this there were no problems with the analysis. No co-variates were significant.

Results

The differences between provenances were not significant (Table 9), but the dry weight of the mean tree ranged from 10 to 15 kg tree⁻¹ with Sudan14 and Israel1 as the extremes, respectively (Fig. 7).

Table 9. Results from analysis of variance of provenance differences of dry weight of the mean tree in trial 26.

Effect	DF	MS	F-value	P-value	Bonferroni sequential tablewise correction
Test of <i>A. tortilis</i> provenances					
Provenance	3	14	0.42	0.75	n.s.
Block	2	280	8.6	0.02	
Error	6	33			

Figure 7. Dry weight of the mean tree in the *A. tortilis* provenances in the trial at Khor Donia, Sudan (Trial no. 26 in the arid zone series). Values presented are least square means with 95 % confidence limits.

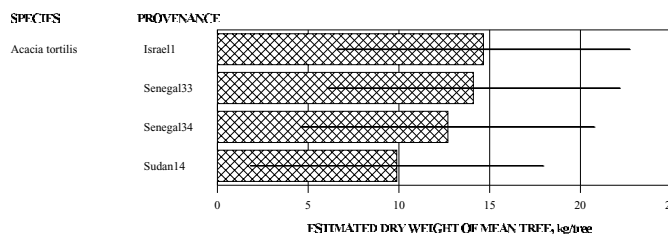

4.8 Total dry weight

As with the total basal area, the total dry weight includes missing trees and gives the best measure of the actual production on the site.

Statistical analysis

The analysis was performed without transformations. Though not significantly different from the Gauss distribution, the distribution of the residuals appeared somewhat strange, and the results should be interpreted with caution. The co-variables plotx, ploty and ploty2 were significant.

Results

In this variable, Senegal33 took the lead with 15 t ha⁻¹ (Fig. 8), corresponding to an annual increment of 1.5 t ha⁻¹. Israel1 and Senegal34 had the lowest values with approximately 4 t ha⁻¹, whereas Sudan14 had a value of 11 t ha⁻¹. According to the analysis of variance, the provenances were significantly different (Table 10). However, the significance disappeared after the correction for multiple comparisons.

Table 10. Results from analysis of variance of provenance differences of total dry weight in trial 26.

Effect	DF	MS	F-value	P-value	Bonferroni sequential tablewise correction
Test of <i>A. tortilis</i> provenances					
Provenance	3	27	18.3	0.02	n.s.
Block	2	0.4	0.3	0.76	
Plotx	1	22	15.0	0.03	
Ploty	1	32	22.6	0.02	
Ploty2	1	36	24.8	0.02	
Error	3	1.5			

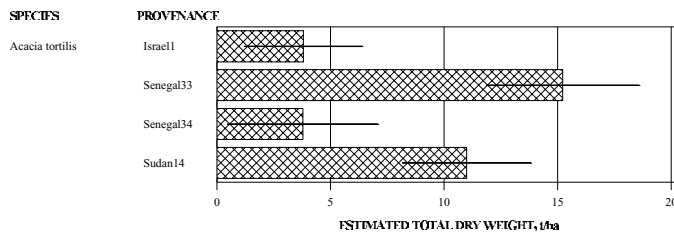

Figure 8. Total dry weight of the mean tree in the *A. tortilis* provenances in the trial at Khor Donia, Sudan (Trial no. 26 in the arid zone series). Values presented are least square means with 95 % confidence limits.

4.9 Multivariate analysis

It was intended to perform the multivariate analysis in two steps: One analysis of the differences between all provenances of the trial, and another in which only the provenances of *A. tortilis* were analysed.

In the analysis of all provenances, the variables survival, height, crown area, number of stems, basal area of the mean tree and the total basal area were included. Since the multivariate analysis does not permit missing values, the two provenances in which the mortality was 100 % were excluded.

According to the analysis there were no significant differences between the provenances (P-value for Wilk's lambda=0.22, P-value for Pillai's trace=0.20). Thus these results differ from the univariate analyses, where in some cases the differences were at the limit of significance.

It was impossible to perform the test of differences between the provenances of *A. tortilis*, as the error degrees of freedom were insufficient. This is partly attributed to the fact that missing values are not included, leaving only 11 observations for the analysis.

5. Discussion and conclusions

Productivity

The best provenance of *A. tortilis* had a production of 1.5 t ha⁻¹ y⁻¹, which corresponds to the production in the parallel trial of *A. nilotica*, also at Khor Donia (trial no. 25 in this series). However, the possibility that the provenances of *A. seyal* and *P. chilensis* would have an even higher production cannot be excluded, since the provenances of both species were higher and had a larger basal area than *A. tortilis*. Both for trial no. 25 and no. 26 the productivity is quite low when compared to the precipitation at the site.

Provenance differences

Only in survival, there were convincing differences between the provenances in the trial. The provenance of *A. albida*, Senegal08, and Senegal32 of *A. tortilis* had no trees surviving at all. These two provenances originate in areas with high precipitation (600 mm) compared to the other provenances, but by no means high compared to the precipitation at the trial site (>700 mm).

For the rest of the provenances, the picture is rather unclear. In the multivariate analysis, there were no signs of significant differences, but in most of the univariate tests the differences were significant and close to being significant when the correction for multiple comparisons was made. With the crown area variable the differences were significant even after the correction for multiple comparisons. Thus the question of provenance differences remains unresolved, and conclusions from the trial should not be drawn too far. Within *A. tortilis*, the differences between provenances were small, and there were few signs indicating statistically valid differences.

Despite the lack of convincing statistical evidence, a more practical approach suggest that it is natural to choose the provenances having the best performance when planning planting programmes. In this trial, the provenances of *A. seyal* and *P. chilensis* together with Senegal33 of *A. tortilis* seemed to have the largest production of biomass and may be considered if further plantations for wood production are needed.

6. References

- Afifi, A.A. and V. Clark. 1996 Computer-aided multivariate analysis. Chapman & Hall, London, 3rd ed., 455 pp.
- Brenan, J.P.M. 1983. Manual on taxonomy of *Acacia* species. Food and Agriculture Organisation of the United Nations, Rome, 47 pp.
- Chatfield, C. and A.J. Collins. 1980 Introduction to multivariate analysis. Chapman and Hall, London.
- DFSC 1994. Preliminary assessment report – trial no. 26. *Acacia tortilis* provenance trial, Khor Donia, Sudan, joint assessment, January 1994. Danida Forest Seed Centre, Humlebaek, Denmark.
- Draper, N. and H. Smith. 1981. Applied regression analysis, second edition. John Wiley & Sons, New York, 709 pp.
- Fagg, C.W. and R.D. Barnes. 1990. African Acacias: Study and acquisition of the genetic resources. Final report, ODA Research Scheme R.4348, Oxford Forestry Institute, UK. 170 pp.
- Graudal, L *et al.* 2003. Introduction to the Evaluation of an International Series of Field Trials of Arid and Semi-arid Zone Arboreal Species'. Danida Forest Seed Centre, Humlebaek, Denmark.
- Graudal, L. *et al.* (in prep.). Biomass regressions for some species of *Acacia* and *Prosopis*.
- Holm, S. 1979. A simple sequentially rejective multiple test procedure. Scandinavian Journal of Statistics 6: 65-70.
- Kjaer, E.D. and H.R. Siegismund, H.R. 1996. Allozyme diversity in two Tanzanian and two Nicaraguan landraces of teak (*Tectona grandis* L.). Forest Genetics 3: 45-52.
- Littell, R.C., G.A. Milliken, W.W. Stroup and R.D. Wolfinger. 1996. SAS® System for mixed models. SAS Institute Inc., Cary, NC, 633 pp.
- Pélissier, P. 1983. Les atlas jeune Afrique: Senegal. Les Editions Jeune Afrique, Paris, 72 pp.
- Ross, J.H. 1979. A conspectus of the African *Acacia* species. Memoirs of the Botanical Survey of South Africa, 44, 155 pp.
- Ræbild, A., C.P. Hansen and E.D. Kjaer. 2002. Statistical analysis of data from provenance trials. DFSC Guidelines and Technical Notes 63. Danida Forest Seed Centre, Humlebaek, Denmark.
- SAS 1988a. SAS® Procedures Guide, Release 6.03 Edition. SAS Institute Inc., Cary, NC, 441 pp.
- SAS 1988b. SAS/STAT® Users Guide, Release 6.03 Edition. SAS Institute Inc., Cary, NC, 1028 pp.
- SAS 1991 SAS® System for Statistical Graphics, First Edition. SAS Institute Inc., Cary, NC, 697 pp.
- Skovgaard, I.M. and P. Brockhoff. 1998 Multivariate analysis and variance components. Lecture notes, Dept. of Mathematics and Physics, The Royal Veterinary and Agricultural University, Copenhagen, 41 pp.
- Snedecor, G.W. and W.G. Cochran. 1980 Statistical methods. Iowa State University Press, 7th ed., 507 pp.
- von Maydell, H.-J. 1986. Trees and shrubs of the Sahel, Their characteristics and uses. TZ-Verlagsgesellschaft, Rossdorf, Germany. 525 pp.

Annex 1. Description of the trial site

Name of site:	Khor Donia (Ed Damazin). Latitude: 11°47'N Longitude: 34°23'E Altitude: 470 m
Meteorological station:	Damazin (FAO 1984)
Rainfall:	Mean (period): 736 mm (FAO 1987)
Rainy season:	May-October Type: Normal with dry period (FAO 1984) Length (days): Intermediate 43, Wet 80 (FAO 1984)
Dry months/year:	No. of dry months (< 50 mm): 8 No. of dry periods: 1
Temperature:	(°C <(FAO 1984)): Annual mean: 28.1 Coldest month: 16.2 Hottest month: 39.5
Wind:	Prevailing directions: Northern dry winter wind December-February, Southern summer wind June-October (Mustafa 1986). Speed at 2 m: 1.6 m/s (FAO 1984)
Topography:	Flat
Soil:	Type: Neutral, black cracking clay soil Depth: Deep
Climatic/agroecological zone:	Semi-arid
Dominant natural vegetation:	<i>Acacia seyal</i> , <i>Balanites aegyptiaca</i> , <i>Compretum spp.</i> , rarely <i>Acacia senegal</i> .
Koepfen classification:	BSh

Annex 2. Seedlot numbers

The plot number refers to the seedlot in the map of the trial, see annex 3. Species codes: aal: *Acacia albida*, asey: *A. seyal*, ato: *A. tortilis*, atora: *A. tortilis* subsp. *raddiana*, pch: *Prosopis chilensis*.

Seedlot numbers			Provenance information								
Provenance	DFSC	Country of origin or CTFT	Plot	Species code	Origin	Country of origin	Latitude	Longitude	Altitude (m)	Rainfall (mm)	No. of mother trees
Senegal08	1042/82	82/618	1042	aal	Bellokho	Senegal	15 20 N	16 21 W	38	600	30
Sudan13		0.717	717	asey	Soba, Khartoum	Sudan	15 27 N	32 40 E	330	165	
Israel1	1012/81		1012	ato	Ein-Hazeva, Arava	Israel	30 47 N	35 12 W	100	40	
Senegal32		80/3257N (CTFT)	3257	atora	Diengue-Dior	Senegal	15 20 N	16 20 W	38	600	
Senegal33	1040/82	82/622	1040	atora	Foret Classe Rao	Senegal	15 56 N	16 23 W	8		30
Senegal34	1041/82	82/621	1041	atora	Foret Classe Keur-Mbaye	Senegal	16 29 N	15 35 W	6		30
Sudan14		0.715	715	atora	Khartoum, West Of The Nile	Sudan	15 36 N	32 33 E	330	165	
Sudan25		0.751	751	pch	Soba, Khartoum	Sudan	15 27 N	32 40 E	330	165	

Annex 3. Design of the trial

Layout of blocks and plots in the field:

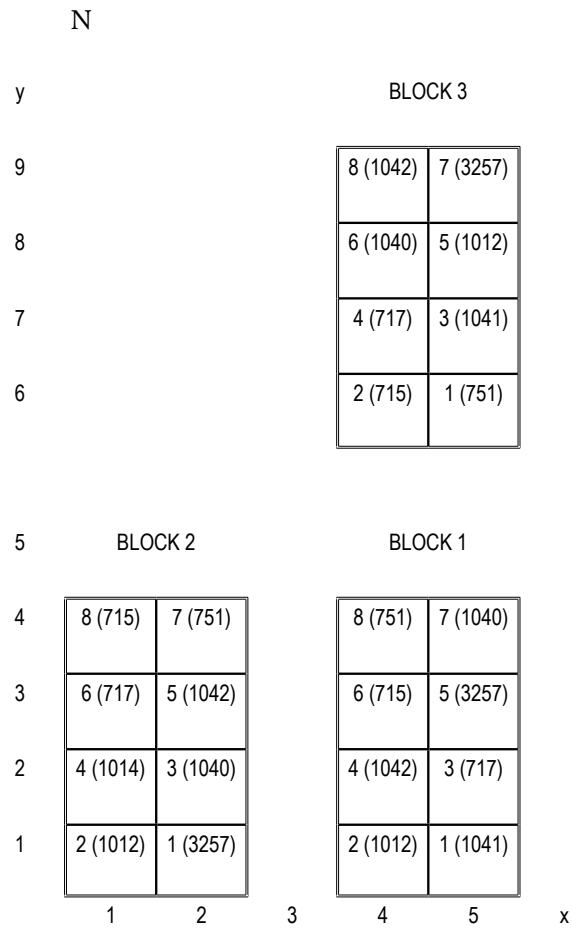

Individual tree positions in each plot:

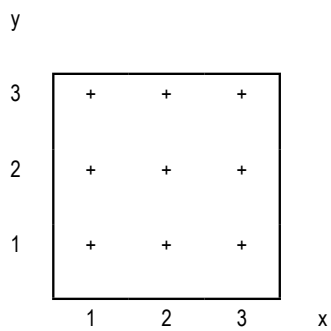

Annex 4. Plot data set

Species codes: aal: *Acacia albida*, asey: *A. seyal*, ato: *A. tortilis*, atora: *A. tortilis* subsp. *raddiana*, pch: *Prosopis chilensis*.

Block	Plotx	Ploty	Species	Provenance	Plot	Survival	Height	Crown area	Number of stems	Basal area of the mean tree	Total basal area	Dry weight of the mean tree	Total dry weight
						%	m	m ² tree ⁻¹	no. tree ⁻¹	cm ² tree ⁻¹	m ² ha ⁻¹	kg tree ⁻¹	t ha ⁻¹
1	4	1	ato	Israel1	2	56	2.92	17.1	1.75	46.4	2.87	17.0	10.50
1	4	2	aal	Senegal08	4	0							
1	4	3	atora	Sudan14	6	56	2.83	14.8	1.33	50.7	3.13	17.3	10.69
1	4	4	pch	Sudan25	8	67	3.54	20.3	1.80	65.5	4.86		
1	5	1	atora	Senegal34	1	89	3.47	9.2	1.00	57.1	5.64	20.7	20.42
1	5	2	asey	Sudan13	3	100	4.94	13.7	1.33	64.9	7.21		
1	5	3	atora	Senegal32	5	0							
1	5	4	atora	Senegal33	7	78	3.10	44.8	1.00	72.5	6.27	27.7	23.96
2	1	1	ato	Israel1	2	67	3.65	26.9	2.00	62.9	1.55	23.7	5.85
2	1	2	atora	Senegal34	4	44	3.93	8.7	1.75	30.6	1.51	9.8	4.83
2	1	3	asey	Sudan13	6	38	4.60	16.1	1.00	47.8	1.77		
2	1	4	atora	Sudan14	8	67	3.26	8.4	1.40	26.4	1.96	8.6	6.36
2	2	1	atora	Senegal32	1	0							
2	2	2	atora	Senegal33	3	89	2.88	1.9	1.50	39.0	3.85	13.1	12.98
2	2	3	aal	Senegal08	5	0							
2	2	4	pch	Sudan25	7	22	4.57	26.2	2.00	92.7	3.43		
3	4	6	atora	Sudan14	2	67	1.89	2.7	1.20	12.5	0.93	3.7	2.77
3	4	7	asey	Sudan13	4	67	4.82	14.9	1.00	58.9	4.36		
3	4	8	atora	Senegal33	6	44	1.77	1.9	1.75	5.9	0.29	1.4	0.71
3	4	9	aal	Senegal08	8	0							
3	5	6	pch	Sudan25	1	67	3.20	27.5	2.67	95.9	7.10		
3	5	7	atora	Senegal34	3	22	0.68	0.6	1.00	23.7	0.59	7.7	1.89
3	5	8	ato	Israel1	5	11	0.90		1.00	12.3	0.15	3.3	0.41
3	5	9	atora	Senegal32	7	0							

Annex 5. Graphical presentation of the health data

The health status of the trees were evaluated on a scale from 0 to 3, where 0 indicates no damage, and 1, 2 and 3 indicates light, moderate and severe damage, respectively. The health status code is named SCSEV in the diagrams on the following pages.

The diagrams present the mean survival ratios, the damage ratios of the surviving trees and the average damage scores for the damaged trees. They also indicate the distribution of the damage on the trees and the cause of the damage. The damage scores are presented according to plots, blocks and seedlots.

Please note that the seedlot codes correspond to the numbers given in annex 2.

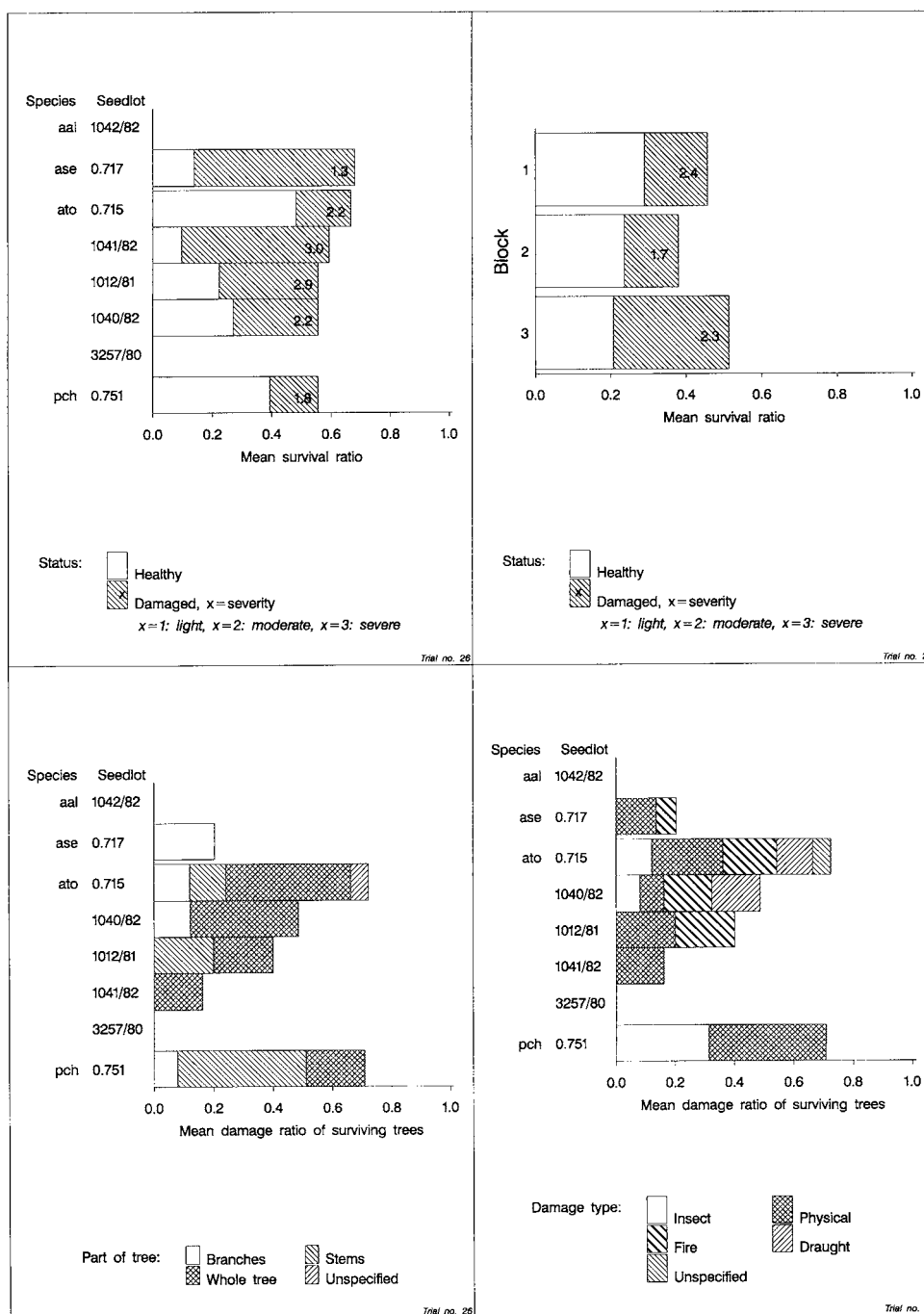

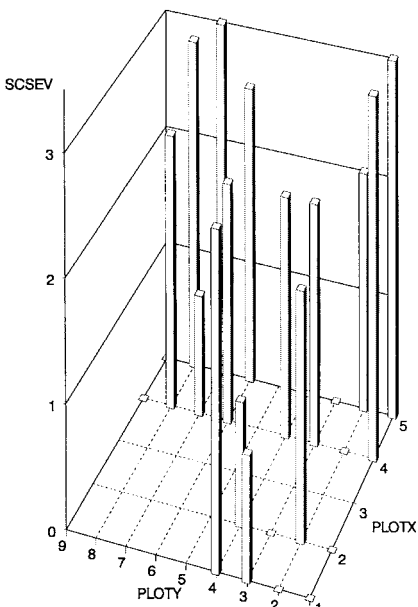

SCSEV = Health status code, severity of attack
Scatter of plot mean values

Trial no. 26

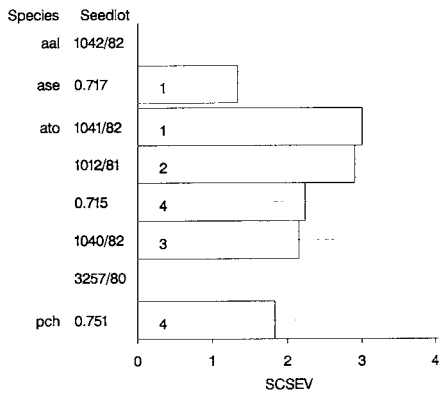

Mean SCSEV of seedlot with error bar line (+/- standard deviation of the mean) and the average number of assessed (living) trees per plot for each seedlot.

Trial no. 26

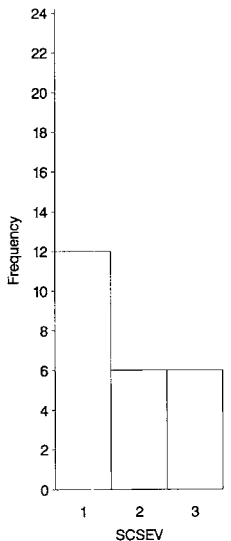

Frequency distribution of plot mean values

Trial no. 26

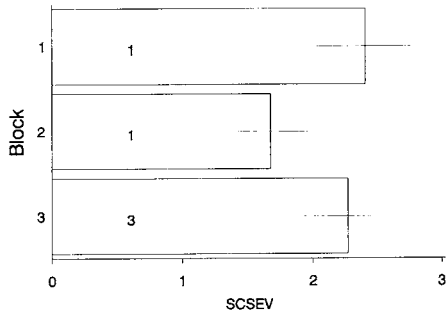

Mean SCSEV of block with error bar line (+/- standard deviation of the mean) and the average number of assessed (living) trees per plot in each block.

Trial no. 26

