



## Seed crop evaluation

Barner, H.; Olesen, Kirsten

*Publication date:*  
1994

*Document version*  
Publisher's PDF, also known as Version of record

*Citation for published version (APA):*  
Barner, H., & Olesen, K. (1994). *Seed crop evaluation*. Danida Forest Seed Centre. Technical note, Vol.. 19

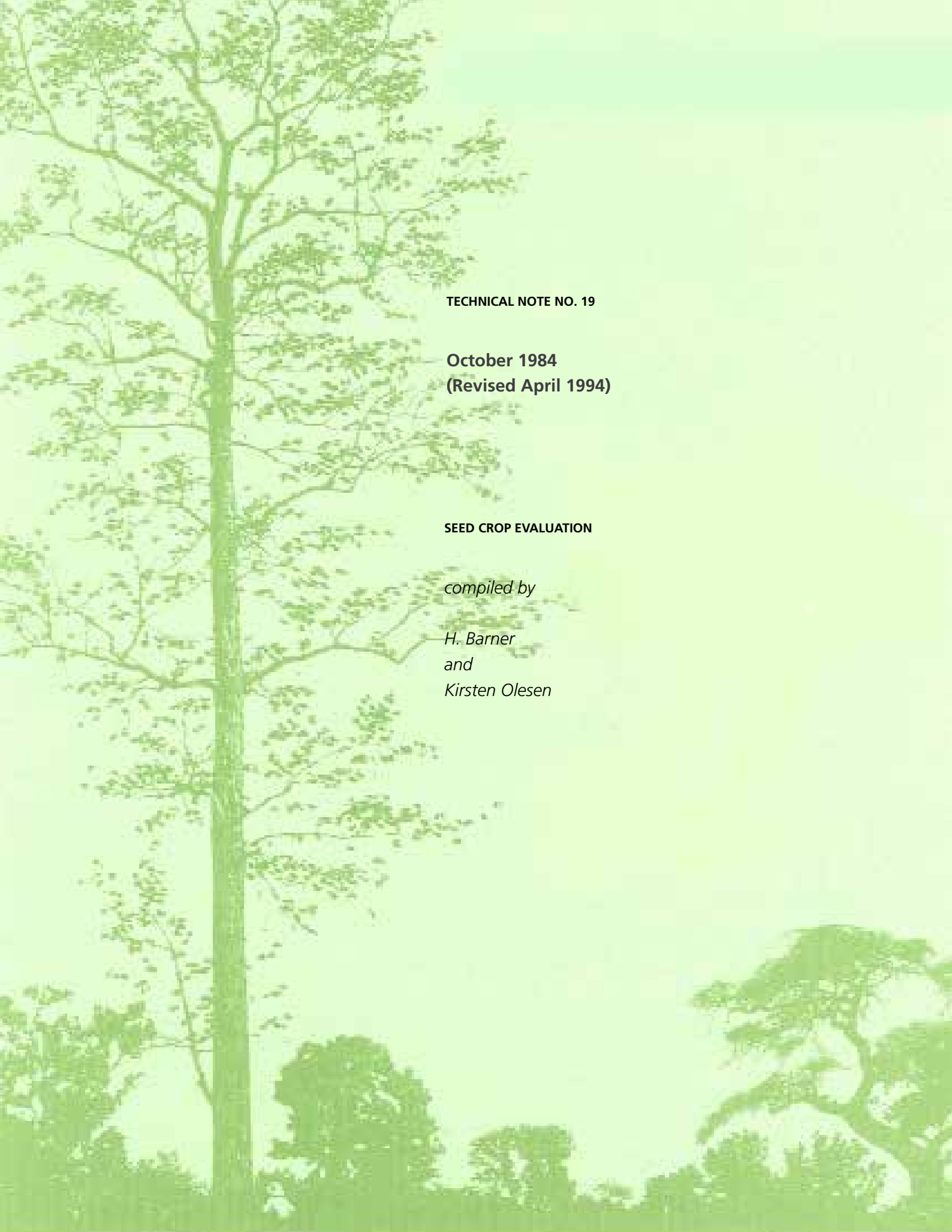

TECHNICAL NOTE NO. 19

October 1984  
(Revised April 1994)

SEED CROP EVALUATION

*compiled by*

*H. Barner  
and  
Kirsten Olesen*



**Titel**

Seed Crop Evaluation

**Author**

H. Barner and Kirsten Olesen

**Publisher**

Danida Forest Seed Centre

**Series - title and no.**

Technical Note no. 19

**ISSN:**

0902-3224

**DTP**

Melita Jørgensen

**Citation**

Barner, H. and Olesen, K. 1984. Seed Crop Evaluation. Technical Note no.19, Danida Forest Seed Centre, Denmark

**Citation allowed with clear source indication**

Written permission is required if you wish to use Forest & Landscape's name and/or any part of this report for sales and advertising purposes.

**The report is available free of charge**

SL-International@life.ku.dk

**Electronic Version**

[www.ign.ku.dk](http://www.ign.ku.dk)

# CONTENTS

|   |           |
|---|-----------|
| <b>1. INTRODUCTION</b>                                      | <b>1</b>  |
| <b>2. COUNTING THE FRUIT</b>                                | <b>2</b>  |
| <b>3. DETERMINING TIME FOR COLLECTION</b>                   | <b>4</b>  |
| 3.1 Specific Gravity of Fruits or Cones                     | 4         |
| 3.2 Examination of Seed Contents                            | 6         |
| 3.3 Colour of Fruits or Cones                               | 6         |
| <b>4. COUNTING FULL SEEDS BY CUTTING TEST</b>               | <b>8</b>  |
| <b>5. REFERENCES</b>  | <b>9</b>  |
| <b>6. APPENDICES</b>  | <b>11</b> |
| 1. Cone ripeness criteria for some pines and spruces        | 11        |
| 2. Fruit ripeness criteria for some tropical tree species   | 13        |
| 3. Number of filled seeds as indicator of collectable crops | 14        |
| 4. Cone cutter  | 15        |
| 5. Cutter for sampling cone seed quality                    | 17        |
| 6. Table model cone cutter                                  | 19        |



# 1. INTRODUCTION

Seed bearing of many trees is rather irregular from year to year. The collection of seed should, if possible, be concentrated in good seed years. This makes the expenditure per kilo seed smaller, and seed quality is normally better in good seed years than in poor years. In order to be able to plan seed collections properly, so that sufficient men and equipment are available, it is necessary to evaluate the fruit crop and seed quality in time.

## 2. COUNTING THE FRUIT

The first evaluation may take place at the time of flowering, and it is possible to estimate (1) that there will be no crop, i.e. when there are no or hardly any flowers, or (2) that there may be a crop, i.e. when there is a reasonable number of flowers which may develop successfully. The fruit crop may be evaluated at the time of fruiting, according to a scale.

The one shown in Table 1 is used in Tanzania (Pleva 1973).

Table 1.

| <b>Crop rating</b> | <b>Criteria</b>   |
|--------------------|---|
| 0 None             | Trees without flowers and fruits  |
| 1 Weak             | Flowering and medium size seed crop on free growing trees and on trees on free borders of stands  |
| 2 Medium           | Flowering and very good crop on free-growing trees and on free borders of stands; trees within the stands bearing crop at the top of crowns |
| 3 Very good        | Flowering and very good crop on most trees  |

In North America the following scale is used extensively, see Table 2. A modified version is shown in Table 3.

Table 2 - (from Dobbs et al.)

| <b>Crop rating</b> | <b>Criteria</b>                            |
|--------------------|--|
| 1 None             | No cones on seed trees *)                  |
| 2 Very light       | Few cones on less than 25 % of seed trees  |
| 3 Light            | Few cones on more than 25 % of seed trees  |
| 4 Medium           | Many cones on 25-50 % of seed trees        |
| 5 Heavy            | Many cones on more than 50 % of seed trees |

\*) Seed trees are upper storey (dominant and co-dominant) trees.

Table 3

| <b>Crop rating</b> | <b>Criteria</b>   |
|--------------------|---|
| 1 Failure          | No cones to a few scattered on a few trees                |
| 2 Very light       | Some cones on some trees                                  |
| 3 Light            | Good to fair crop on 1/2 of exposed crown of 1/2 trees    |
| 4 Medium           | Good to medium crop on 3/4 of exposed crown of most trees |
| 5 Heavy            | Good crop of cones on all exposed crowns of most trees    |

A rating of 4 or 5 is good prospect for all pickers. A rating of 3 has possibilities for more experienced pickers. A rating of 1 or 2 is poor prospect for all pickers.

In Arizona and New Mexico a ten-class system is used for conifers (Schubert & Pitcher , 1973). The cone-crop rating is based on the relative number of cones produced on a proportion of the seed trees at each sampling area. A seed tree, in this case, is defined as a dominant tree over 30 cm in diameter with a full, vigorous crown. The 10-unit system provides intermediate ratings between those of lesser-unit classifications. An exact cone count is not required for a reasonable evaluation of the cone-crop rating. See Table 4.

Table 4

| Classification        | Description *)   |
|-----------------------|--|
| 1 None                | No cones on any seed tree  |
| 2 Very light          | Few cones on less than 1/4 of seed trees   |
| 3 Very light to light | Few cones on 1/4 to 1/2 of the seed trees  |
| 4 Light               | Few cones on more than 1/2 of the seed trees   |
| 5 Light to medium     | Few cones on more than 1/2 and many cones on less than 1/4 of the seed trees               |
| 6 Medium              | Many cones on 1/4 to 1/2 of the seed trees   |
| 7 Medium to heavy     | Many cones on more than 1/2 of the seed trees  |
| 8 Heavy               | Many cones on more than 1/2 of the seed trees with less than 1/4 of them loaded cones      |
| 9 Heavy to very heavy | Many cones on more than 1/2 of the seed trees with 1/4 to 1/2 of them loaded with cones    |
| 10 Very heavy         | Many cones on more than 1/2 of the seed trees with more than 1/2 of them loaded with cones |

\*) Cones per tree: few = 1-20; many = 21-160; loaded = 161 or more

In earlier years a fruit crop might be evaluated in such vague terms as 'half crop', 'full crop' or 'super crop', which covered a variety of crop sizes according to the disposition of the evaluator.

A scale which states the size of the crop in proportion to a full crop is known from Germany (Rohmeder 1972):



Table 5

| Crop rating           | Criteria   |
|-----------------------|--|
| 1 0%                  | No crop/failure  |
| 2 10-30 % poor crop   | Fruits on some trees along stand edges;<br>inside stand only on a few dominant trees |
| 3 40-60 % medium crop | Fruits on most trees along stand edges;<br>inside stand only on dominant trees       |
| 4 70-90 % good crop   | Almost all trees (except suppressed trees)<br>bear fruits                            |
| 5 100 % full crop     | All trees (except suppressed trees) bear<br>fruits                                   |

Crop rating requires some training. It is important that the rating takes place within the stand (not only along roads or other stand edges) and on trees that are representative of the stand. Good field glasses are essential, a minimum of 50 mm aperture and magnification x7 or x8 are suitable. A common error is that old cones are included in the counting. It should be remembered that for practical collection purposes where climbing is necessary, it is not a matter of counting all fruits or cones, but of counting those that are accessible.

### 3. DETERMINING TIME FOR COLLECTION

Seed collectors must be able to time collection for the period when seeds are fully ripe but before they are dispersed by fruit dehiscence or consumed by animals. To achieve this aim, collectors must be able to distinguish between ripe and unripe seeds/fruits, and the success of the collection depends largely on the experience of the collector.

Different laboratory methods exist for determining the ripeness of fruit, e.g. dry-weight determination, chemical analyses, x-ray radiography, and determination of the moisture content.

Described below are some field methods (mostly as summarized by Wil1an, 1985).

#### 3.1. Specific Gravity of Fruits and Cones

As moisture content of fruits and cones decreases with maturation, specific gravity or density (i.e. the ratio of unit weight to unit volume) will also decrease. Unlike moisture content, it is not too difficult to determine approximate specific gravity in the field by flotation in liquids of known specific gravity. Specific gravity indices of maturity have been established for cones of a number of "coniferous" species; the cone to be tested is placed in a liquid in which it will float if mature and sink if immature (Stein et al. 1974). Various mixtures of kerosene (SG = 0.80), light SAE 20 motoroil (SG=0.88) and linseed oil (SC = 0.93) have been used to prepare flotation liquids having a designated specific gravity. Tests must be made immediately after cones are picked from a tree.

Specific gravity indices have proved reliable for some temperate conifers e.g. an SG of 0.74 for *Picea glauca* (Cram and Worden 1957), but not for several southern hardwoods in the USA (Bonner 1972); cf. section 3.3 on colour of fruits and cones.

For *Pinus caribaea* the guideline is that if more than 3/4 of a cone sample floats in water (specific gravity = 1), then collection can start in the area that the sample represents (Hughes 1981).

Further details for some pine and spruce species are found in Table 6 (Schopmeyer 1974).

Table 6

Specific gravity of ripe pine cones and liquids used for testing ripeness by flotation.

| Species                                  | Specific gravity of ripe cones | Flotation test liquid <sup>1</sup>                          |
|--|--------------------------------|---|
| <i>P. aristata</i>                       | 0.59-0.80                      | kerosene  |
| <i>P. contorta</i> var. <i>latifolia</i> | 0.43-0.89                      |   |
| <i>P. densiflora</i>                     | 1.10                           |   |
| <i>P. echinata</i>                       | 0.88                           | SAE 20 motor oil, or 1 part kerosene to 4 parts linseed oil |
| <i>P. edulis</i>                         | 0.80-0.86                      | ketosene  |
| <i>P. elliotii</i>                       |                                |   |
| var. <i>donsa</i>                        | <0.89                          | SAE 20 motor oil  |
| var. <i>elliottii</i>                    | <0.90                          | SAE 20 motor oil  |
| <i>P. glabra</i>                         | 0.88                           | SAE 20 motor oil  |
| <i>P. jeffreyi</i>                       | 0.81-0.86                      |   |
| <i>P. lambertiana</i>                    | 0.70-0.80                      |   |
| <i>P. palustris</i>                      | 0.80-0.89                      | SAE 20 motor oil  |
| <i>P. ponderosa</i>                      |                                |   |
| var. <i>arizonica</i>                    | 0.88-0.97                      | kerosene  |
| var. <i>ponderosa</i>                    | 0.80-0.86                      | ketosene  |
| var. <i>scopulorum</i>                   | <0.85                          | water   |
| <i>P. radiata</i>                        | <1                             | ketozene <sup>2</sup>                                       |
| <i>P. resinosa</i>                       | 0.80-0.94                      |   |
| <i>P. serotina</i>                       | 0.88                           | 95% ethanol   |
| <i>P. strobiformis</i>                   | 0.85-0.95                      | Linseed oil   |
| <i>P. strobus</i>                        | 0.92-0.97                      |   |
| <i>P. sylvestris</i>                     | 0.88- 1.00                     | SAE 20 motor oil, or 1 part kerosene to 4 parts liaseed oil |
| <i>P. taeda</i>                          | 0.88                           |   |
| <i>P. virginiana</i>                     | <1.00                          |   |

1 Test should be made as soon after picking as possible to prevent excessive drying; the liquids have the following specific gravities: kerosene 0.80, 95 percent ethanol 0.82, SAE 20 motor oil 0.88, linseed oil 0.93. Five or more freshly picked cones should float before crop is considered ripe.

2 Red pine cones which float in a 50-50 mixture of linseed oil and kerosene are within 10 days of being ripe.

When the relationship between seed maturity and specific gravity of freshly picked cones has been established, a container of suitable liquid with known specific gravity can be taken into the field for testing relative specific gravity of cone samples.

### 3.2 Examination of Seed Contents

Examination of seed contents exposed by cutting open fruits or cones lengthwise can be a reliable and simple method of assessing seed ripeness, provided the operator is experienced. Most embryos and endosperm pass through an immature 'milk' stage, followed by a 'dough' stage when the tissue becomes firmer. Mature seeds have a firm white endosperm (where present) and a firm fully developed embryo (Turnbull 1975).

For further details on the cutting test, see section 4.

### 3.3 Colour of Fruits or Cones

Colour changes in fruits or cones provide a simple and, in some species, reliable criterion for judging seed maturity, but the operator must be experienced in the characteristics of the species concerned. In common with the specific gravity method, it involves no destruction of the seeds in the sample examined. Colour changes are usually from green of the immature fruit or cone to various shades of yellow, brown or grey, and this may be accompanied by hardening of cone scales or of the pericarp of dehiscent or woody fruits.

Fruits that are fleshy and do not dry out on the tree are ready for collection when they have changed from green to their normal ripe colour. When the fruits of such species are cut in halves, the contents of the seed should be white, firm and fill the seedcoat with a few empty spaces (Robbins & Shrestha 1986).

Colour change was found to be the most reliable indicator of maturity for general practice in several southern hardwoods in the USA (Bonner 1972). It has also given good results in a number of temperate conifers. In Malaysia, Tamari (1976) found that the best results were obtained by collecting *Dipterocarp* fruits when the wings turned brown but before the fruit itself changed colour.

Maturity of seeds of dehiscent acacia species is usually indicated by the cracking of the dark coloured pods. With indehiscent acacia species the darkening of the pods is also the main indicator of maturity. Collection of 'green' acacia seed has been advocated as a means of arresting severe bruchid attack and avoid the need for presowing treatment, and it has worked well with *Acacia mearnsii*, *A. senegal* and *A. tortilis subsp. raddiana* and several Australian acacias (e.g. *A. salicina*) (Doran et al. 1983).

Since the seed normally matures before the fruit, it is advisable in some species to time collection at an earlier rather than a later stage of the colour change.

In Thailand cone colour is used as a guide to optimise time of collection of pines, but it differs according to species. In *Pinus kesiya* collection starts when cones have hardened and the colour is changing from green to brown in proportions of 50 : 50. In *Pinus merkusii* optimum time of collection is reached when the majority of cones are brownish and some have started to open (Granhof 1975). Trials with the Zambales (Philippines) provenance of *P. merkusii* have shown not only that extraction is a much more lengthy and expensive operation with green than with brown cones but also that the seed extracted has lower germination rate (Gordon et al - 1972).

About *Pinus caribaea* in Honduras, Robbins (1983 a) states: 'Estimation of maturity is best done using several indices, since none is sufficiently reliable by itself. Cones should generally be more than half-brown

in colour, and when cut in two, the cone axis should be dark-brown. If the apex of the cone is pressed with the thumb, it should feel firm, the scales easily cracking open, coloured light-brown on the interior surfaces. The seed coat must be darkening in colour, and the gametophytic tissue and embryo should be firm and nearly white or completely filling their respective cavities.'

For *Pinus oocarpa* in Honduras, Robbins (1983 b) states: 'The best maturity index of the cone crop is cone colour, and cones should be collected when totally brown. Because the period from cone maturation to cone opening in individual trees is quite long (1 - 2 months), and there is considerable variation in maturing times between stands, collection operations can be extended over several months, and it is not normally necessary, nor advisable, to collect green cones. If green cones have to be collected, they should have a greasy appearance and a dark green/brown colour that is lending to yellow/brown.'

According to Schopmeyer (1974), cones of *Pinus patula* are ripe when they are yellow-ochre to nut-brown, *P. roxburghii* when they are light-brown and *P. wallichiana* when they are tawny-yellow to light-brown. Cones of *P. roxburghii* may be collected while they are still green, as the seeds ripen early, and cones of *P. wallichiana* should be collected as soon as they are about to open or just before (FAO 1956).

When the bladder like involucre of teak (*Tectona grandis*) seeds turn from green to brown, the seeds are ripe (Schopmeyer 1974). Experience from Thailand show that the most viable fruits of teak are those that are shed last, so collection operations should be timed accordingly (Hedegart 1975).

When ripe, fruits of *Gmelina arborea* are yellow with a leathery shining pericarp. Eucalypt seeds are usually ripe when the fruits become brown and hard, but seeds may be viable before the fruits appear fully matured (Boland et al. 1980).

Seed of *Terminalia* species appear brown even when they are unripe. Careful observation is important to ensure that the seeds are mature before harvest (Mbonye & Kiambi).

Appendix 1 gives a list of some pine and spruce species and the colour criteria for the ripeness of the cones.

Appendix 2 gives a list of some tropical species and the fruit colour at maturity.

## 4. COUNTING FULL SEEDS BY CUTTING TEST

A medium or heavy cone or fruit crop is no guarantee for a good seed yield. Seed quality should be assessed concurrently with the rating of the fruit crop. For practical reasons, such an assessment is often not carried out in due time before the time of collection. But as a minimum, seed maturity and seed quality must be assessed on **a number of representative trees the first day of collection**. Much money may be wasted if collections are carried out blindly.

The seed-crop evaluation involves observing the inside of seeds by slicing fruits or cones in halves lengthwise and evaluating the ripeness and quality of the exposed seeds, including the incidence of damage by pests and diseases.

The slicing of fruits and cones can be done with a knife, a pair of pincers or the like. For cones, in particular pine cones some of which are very hard, a cone cutter is recommended, see appendices 4-6. Cones may also be forced open by being dipped in boiling water for 10-20 seconds and then placed at 50- 60°C for a couple of hours.

When counting the number of full seeds on the cut surface, only normal seeds should be included. Underdeveloped seeds, which often occur at the top or base of cones, should not be included.

The exposed seeds should be examined carefully with a X10 hand lens.

The relationship of the total number of full seeds per cone to number of full seeds exposed on a cut surface is known for some species, for example a factor of x4 or x5 has been found appropriate for *Pseudotsuga* in the western USA. For many tropical species such factors are not known and need to be established under local conditions.

For *Pinus caribaea* the ratio of the number of cut seeds per surface to full seeds per cone is from 1 : 12 to 1 : 18. Average counts for natural stands are 1 - 5 cut seeds representing 14-80 full seeds per cone. Yields from coastal provenances of *P. caribaea* var. *hondurensis* tend to be much lower than inland provenances. For *Pinus caribaea* the relation between the number of cut seeds per surface and full seeds per cone is approximately 1:10 for small cones, 1:20 for large cones. Average counts for natural stands are 1-3 cut seeds, representing 10-40 full seeds per cone (Robbins 1983 b).

For a number of temperate species' see appendix 3.

The final decision on whether a seed crop collection is heavy enough to justify a seed collection should depend on the rating of the crop as well as the result of the cutting tests.

## 5. REFERENCES

- Boland, D.J., Brooker, M.I.H, Turnbull, J.U. & Kleinig, D.A. 1980  
Eucalyptus Seed. Division of For. Res., CSIRO Canberra.
- Bonner, F.T. 1972  
Technology of eastern tree seed - a five year report on research. Proc' S.E. Area For. Tree Nursery-men's Conf., Mississippi and N. Carolina : 13-21.
- Cram, W.H. & Worden, H.A. 1957  
Maturity of white spruce cones and seed. For. Sci. 3: 263-269.
- DeBarr, Gary L. & Proveaux, M.T. 1969  
A New Table Model Cone Cutter. Tree Planters' Notes, Vo1.19 No.4.
- Dobbs, R.C., Edwards, D.G.W., Konishi, J. & Wallinger, D. 1976  
Guideline to Collecting Cones of B.C. Conifers. British Columbia Forest Service/Canadian Forestry Service. Joint Report No. 3.
- Doran, J.C., Turnbull, J.W., Boland, D.J. & Gunn, B.V. 1983  
Handbook on Seeds of Dry-zone Acacias. FAO.
- F.A.O. 1956  
Tree Planting Practices in Temperate Asia. Burma - India - Pakistan. FAO For. Dev. Paper 10.
- Gordon, A.G., Estaban, I.D & Wakeman, D.C. 1972  
Cone handling, seed quality and seed testing of *Pinus merkusii*. Commonw. For. Rev. 51 (1).
- Granbois, J. 1975  
Seed collection of pine. In: Report on FAO/Danida Training Course Forest Seed Collection and Handling. Vol. 2. FAO Rome.
- Hedegart, T. 1975  
Seed collection of teak. In: Report on FAO/Danida Training Course Forest Seed Collection and Handling. Vol. 2. FAO Rome.
- Hughes, C.E., 1981  
Cone opening of *P. caribaea var hondurensis* in relation to cone density and cone moisture content. Internal- Note, Banco de Semillas, ESNACIFOR, Honduras.
- Mbonye, Arsen & Kiambi, Kibika, 1984  
How to collect, handle and store seeds. Kengo Indigenous Trees Training Series. Kenya.
- Pleva, J.R. 1973  
Some remarks to seed procurement in Tanzania. In: "Seed Processing" Proc. Symposium IUFRO Wkg. Group on Seed Problems, Bergen, Vol. II. Paper 24.
- Prasad, Rem & Kandy, A.K. 1992  
Handling of Forestry Seeds in India. Associated Publishing Company, New Delhi.
- Robbins, A.M.J. 1983 a  
*Pinus caribaea* Morelet. Danida Forest Seed Centre, Seed Leaflet No. 2.
- Robbins, A.M.J. 1983 b  
*Pinus oocarpa* Schiede. Danida Forest Seed Centre, Seed Leaflet No. 3.
- Robbins, A.M.J. & Shrestha, N.B. 1986  
Tree Seed Handling. Field Document No. 11. Community Forestry Development Project. Kathmandu, Nepal.
- Robmeder, Ernst 1972  
Das Saatgut in der Forstwirtschaft. Paul Parey Hamburg und Berlin.
- Schopmeyer, C.S. 1974  
Seeds of Woody Plants in the United States. Forest Service. US Dept. of Agriculture. Agricultural Handbook No. 450.

*Schubert, G.H. & Pitcher, J.A. 1973*

A Provisional Tree Seed Zone and Crop Rating System from Arizona and New Mexico. USDA Forest Service Res. Pap. RM-105.

*Stein, W.I., Slabaugh, P.E. & Plummer, A.P. 1974*

Harvesting, processing and storage of fruits and seeds. In: Seeds of Woody Plants in the United States, Agricultural Handbook No. 450.

*Syverson, Martin L. 1960*

Cone Cutter. Tree Planters' Notes No. 42.

*Tamari, C. 1976*

Phenology and seed storage trials of *Dipterocarps*. Res. Pamphlet No. 69, For. Res. Inst. Kepong, Malaysia.

*Turnbull, J.W. 1975*

Assessment of seed crops and the timing of seed collections. In: Report on FAO/Danida Training Course on Forest Seed Collection and Handling, Vol. 2, FAO Rome.

*Willan, R.L. 1985*

A Guide to Forest Seed Handling. FAO Forestry Paper 20/2.

*Wilson, Boyd C. 1968*

A Cutter for Sampling Cone Seed Quality. Tree Planters' Notes, Vol. 19 No. 2.

## CONE RIPENESS CRITERIA FOR SOME PINES AND SPRUCES (Schopmeyer 1974)

Pinus:

| Species  | Pre-ripe color               | Ripe color   | Species  | Pre-ripe color                              | Ripe color   |
|--|------------------------------|--|--|---|--|
| <i>P. albicaulis</i> .....                       | dark purple.....             | dull purple to brown                                 | <i>P. koraiensis</i> .....                           |   | yellowish brown.   |
| <i>P. aristata</i> .....                         | green to brownish<br>purple. | deep chocolate brown                                 | <i>P. lambertiana</i> .....                          | green.....                                  | lustrous greenish brown<br>to light brown.                           |
| <i>P. armandii</i> .....                         | green.....                   | yellowish brown                                      | <i>P. leiophylla</i> var<br><i>chihuahuana</i> ..... | green.....                                  | light brown  |
| <i>P. attenuata</i> .....                        | greenish brown.....          | lustrous tawny yellow<br>to light brown.             | <i>P. merkusii</i> .....                             | do.....                                     | light brown.   |
| <i>P. balfouriana</i> .....                      | deep purple.....             | dark brown, red brown<br>or russet brown.            | <i>P. monophylla</i> .....                           | do.....                                     | shining deep russet<br>brown.  |
| <i>P. banksiana</i> .....                        | green.....                   | lustrous tawny yellow<br>to brown.                   | <i>P. monticola</i> .....                            | green to purple<br>black.                   | yellowish or beige brown<br>thru reddish brown<br>and dark brown.    |
| <i>P. brutia</i> .....                           | do.....                      | yellow to reddish brown                              | <i>P. mugo</i> .....                                 | violet purple.....                          | lustrous tawny yellow<br>to dark or cinnamon<br>brown.               |
| <i>P. canariensis</i> .....                      |                              | nut brown  | <i>P. muricata</i> .....                             | green to purple.....                        | shiny light chestnut<br>brown.                                       |
| <i>P. caribaea</i> .....                         |                              | yellow tan to light brown                            | <i>P. nigra</i> .....                                | yellowish green.....                        | shiny yellow brown to<br>light brown.                                |
| <i>P. cembra</i> .....                           | greenish violet.....         | purplish brown                                       | <i>P. palustris</i> .....                            | green.....                                  | green to dull brown  |
| <i>P. cembroides</i> .....                       | green.....                   | yellowish to reddish<br>brown, or lustrous<br>brown. | <i>P. patula</i> .....                               |   | yellow ochre to nut brown.   |
| <i>P. clausa</i> .....                           |                              | dark yellow brown                                    | <i>P. parviflora</i> .....                           |   | leathery-woody, brownish<br>red to reddish brown.                    |
| <i>P. contorta</i><br>var. <i>contorta</i> ..... | purple green.....            | lustrous light yellowish<br>brown to yellow brown.   | <i>P. peuce</i> .....                                | green to yellow.....                        | tawny yellow to light<br>brown.                                      |
| var. <i>latifolia</i> .....                      | do.....                      | light brown  | <i>P. pinaster</i> .....                             | purplish.....                               | lustrous light brown   |
| var. <i>murrayana</i> .....                      | do.....                      | clay brown   | <i>P. pinea</i> .....                                | green.....                                  | shiny nut brown  |
| <i>P. coulteri</i> .....                         | green.....                   | shining brown to yel-<br>lowish brown.               | <i>P. ponderosa</i><br>var. <i>arizonica</i> .....   | do.....                                     | green brown to dull<br>yellowish buff or<br>brown.                   |
| <i>P. densiflora</i> .....                       |                              | dull tawny yellow to<br>brown.                       | var. <i>ponderosa</i> .....                          | green to yellow<br>green, rarely<br>purple. | lustrous brownish green<br>or yellow brown to<br>to russet brown.    |
| <i>P. echinata</i> .....                         | green.....                   | green to light or dull<br>brown.                     | var. <i>scopulorum</i> .....                         | green.....                                  | purplish brown   |
| <i>P. edulis</i> .....                           | do.....                      | light yellow brown                                   | <i>P. sumilata</i> .....                             | green to violet<br>purple.                  | dull reddish or yellowish<br>brown.                                  |
| <i>P. elliotii</i><br>var. <i>densa</i> .....    | do.....                      | brown  | <i>P. pungens</i> .....                              | deep green to<br>brown.                     | lustrous light brown   |
| var. <i>elliottii</i> .....                      | do.....                      | brown yellow to brown                                | <i>P. quadrifolia</i> .....                          | green.....                                  | yellowish or reddish<br>brown.                                       |
| <i>P. engelmannii</i> .....                      | brownish purple<br>green.    | light brown  | <i>P. radiata</i> .....                              | do.....                                     | lustrous nut brown to<br>light brown.                                |
| <i>P. flexilis</i> .....                         | green.....                   | lustrous yellowish to<br>light brown.                | <i>P. resinosa</i> .....                             | do.....                                     | purple with reddish<br>brown scale tips to<br>nut brown.             |
| <i>P. gerardiana</i> .....                       | do.....                      | brown  | <i>P. rigida</i> .....                               | do.....                                     | lustrous brown or light<br>yellow brown.                             |
| <i>P. glabra</i> .....                           | do.....                      | green  | <i>P. roxburghii</i> .....                           | green to brown.....                         | light brown  |
| <i>P. halepensis</i> .....                       | do.....                      | lustrous yellowish brown<br>or reddish brown.        | <i>P. sabiniana</i> .....                            | green to light<br>brown.                    | reddish to red or chest-<br>nut brown.                               |
| <i>P. heldreichii</i> .....                      |                              | yellowish or light to<br>dull brown.                 | <i>P. serotina</i> .....                             |   | lustrous light yellow<br>to brown.                                   |
| <i>P. insularis</i> .....                        | green.....                   | bright brown to dark<br>brown.                       | <i>P. sibirica</i> .....                             | green.....                                  | violet to light gray or<br>brown.                                    |
| <i>P. jeffreyi</i> .....                         | dark purple to<br>black.     | dull purple to light brown.                          | <i>P. strobiformis</i> .....                         | do.....                                     | greenish brown to dark<br>brown.                                     |
|  |                              |  | <i>P. strobus</i> .....                              | green.....                                  | yellow green to light<br>brown.                                      |
|  |                              |  | <i>P. sylvestris</i> .....                           | do.....                                     | dull tawny yellow, grey-<br>ish or dull brown, or<br>cinnamon brown. |
|  |                              |  | <i>P. taeda</i> .....                                | do.....                                     | green, shiny light brown,<br>or dull pale reddish<br>brown.          |
|  |                              |  | <i>P. thunbergiana</i> .....                         | deep lustrous<br>purple.                    | nut or reddish brown   |
|  |                              |  | <i>P. torreyana</i> .....                            | green to dark<br>violet.                    | shiny deep chestnut<br>brown to chocolate<br>brown.                  |
|  |                              |  | <i>P. virginiana</i> .....                           | green.....                                  | lustrous dark purple to<br>reddish brown and<br>dark brown.          |
|  |                              |  | <i>P. wallichiana</i> .....                          | do.....                                     | tawny yellow to light<br>brown.                                      |



**Picea:**

| Species                     | Preripe color                 | Ripe color                  |
|-----------------------------|-------------------------------|-----------------------------|
| <i>P. abies</i> .....       |                               | Brown.                      |
| <i>P. asperata</i> .....    |                               | Fawn grey.                  |
| <i>P. breweriana</i> .....  | Green.....                    | Brown to black.             |
| <i>P. engelmannii</i> ..... | Green tinged with<br>crimson. | Shining brown.              |
| <i>P. glauca</i> .....      | Green.....                    | Pale brown.                 |
| <i>P. glehnii</i> .....     |                               | Shining brown.              |
| <i>P. jezoensis</i> .....   | Crimson.....                  | Leather brown.              |
| <i>P. koyamai</i> .....     | Pale green.....               | Shining brown.              |
| <i>P. mariana</i> .....     | Green.....                    | Purple turning<br>to brown. |
| <i>P. omorika</i> .....     | Bluish black.....             | Dark brown.                 |
| <i>P. orientalis</i> .....  | Purple.....                   | Brown.                      |
| <i>P. polita</i> .....      | Yellowish green.....          | Cinnamon.                   |
| <i>P. pungens</i> .....     | Green tinged with<br>red.     | Pale shining<br>brown.      |
| <i>P. rubens</i> .....      | Green or purplish             | Shining brown.              |
| <i>P. sitchensis</i> .....  | Light yellow green            | Yellow red                  |
| <i>P. smithiana</i> .....   | Bright green.....             | Bright brown.               |

## Fruit Ripeness Criteria for Some Tropical Tree Species

(Prasad & Kandya L992)

| Species                | Fruit Colour at maturity |
|------------------------|--------------------------|
| Acacia auriculiformis  | Brown                    |
| Acacia senegal         | Bronze                   |
| Albizia procera        | Yellowish                |
| A. lebbek              | Light brown              |
| Bauhinia variegata     | Brown                    |
| Cassia siamea          | Brownish black           |
| Cassia fistula         | Light brown              |
| Dendrocalamus strictus | Yellowish brown          |
| Leucaena latisiliqua   | Brownish                 |
| Leucaena leucocephala  | Dark brown               |
| Mitragyna parviflora   | Light brown              |
| Prosopis juliflora     | Golden brown             |
| Wrightia tinctoria     | Yellowish grey           |

Number of filled seeds as indicator of collectable crops (Dobbs et al . 1976)

**Minimum Number of Filled Seeds for Collectable Crops**

| Species                    | per half cone | per cone |
|----------------------------|---------------|----------|
| Chamaecyparis nootkatensis | 6-8           | 2        |
| Larix occidentalis         | 7-10          | 40       |
| Picea engelmanni           | 7-10          |          |
| - glauca                   | 7-10          |          |
| - sitchensis               |               |          |
| Pinus contorta             |               | 20       |
| - monticola                |               | 90       |
| - ponderosa                |               | 75       |
| Pseudotsuga menziesii      | 5-7           |          |
| Tsuga heterophylla         | 3-4           |          |

**Average Number of Filled Seeds Exposed per Half Cone**

| Species               | for medium crop *) | for heavy crop |
|-----------------------|--------------------|----------------|
| Pseudotsuga menziesii | 5                  | 7              |
| Picea spp.            | 7                  | 10             |
| Tsuga heterophylla    | 3                  | 4              |
| Larix spp.            | 6                  | 8              |

\*) Recommended minimum counts for collectable crops. These figures are only applicable just prior to collection because insects or disease may further decrease counts if there is a significant time lag between examination and collection.

## CONE CUTTER

Martin L. Syverson, Forester  
Division of State & Private Forestry, U. S. Forest Service  
Portland, Ore.

Good coniferous seed depends on the cone collector making cut tests on several cones from each tree before picking begins. The cone cutter should be lightweight, pocket-sized, and safe and simple to operate. The homemade cone cutter (see illustration on following page) is patterned after one first made by Horner Ward, Nurseryman, State of Washington Department of Natural Resources. It is made from a piece of metal conduit, saw blade, hardwood and rivets for handle, and a bolt to hinge the blade. Best results are obtained when the blade is kept sharp and the cone is cut lengthwise through the center with its tip facing away from the handle. A dull blade will compress the cone and make a ragged cut. This results in an inaccurate seed count. Cone collectors and buyers make cut tests to:

- (1) Determine seed maturity.
- (2) Determine the seed count of a cone.
- (3) Observe cone quality (pitch, worms, etc.).

Tests for maturity start about the first of August. To be sufficiently mature, seed must be ripened beyond the 'milk' stage and contain a solid white kernel. The seed count is determined by the number of sound seed kernels exposed by the cut on either half section of the cone. Seed count requirements vary with the species. Cone buyers usually require not less than six seed counts for Douglas-fir.

In the Pacific Northwest, cone picking usually starts in the middle of August for lower elevations and continues to early November for high elevations.

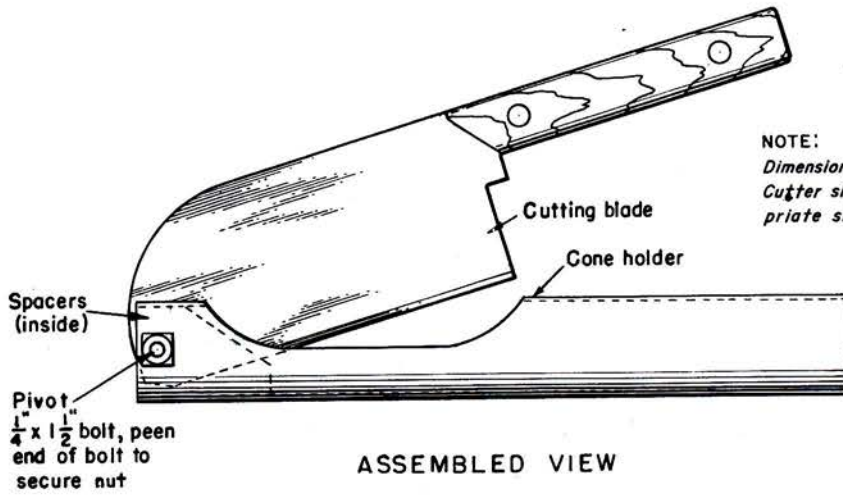

NOTE:  
 Dimensions shown are proportionate.  
 Cutter should be built to an appropriate size for cone.

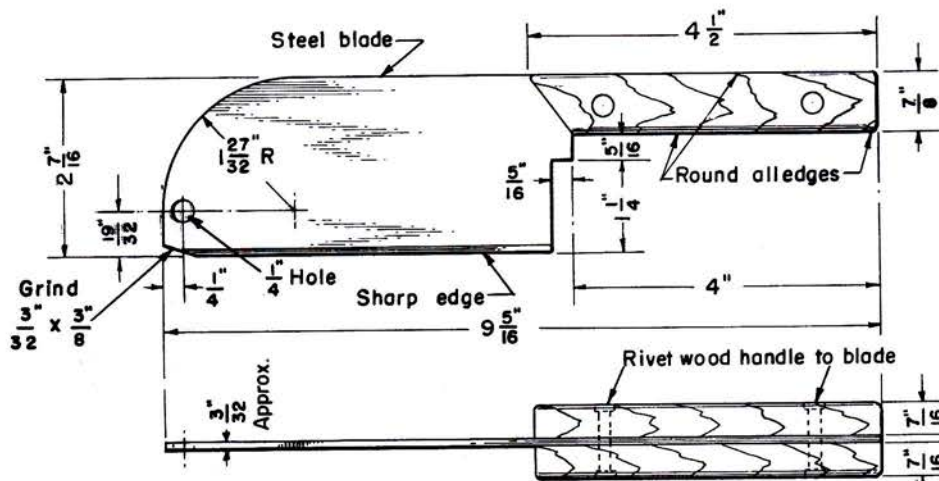

DETAIL OF BLADE

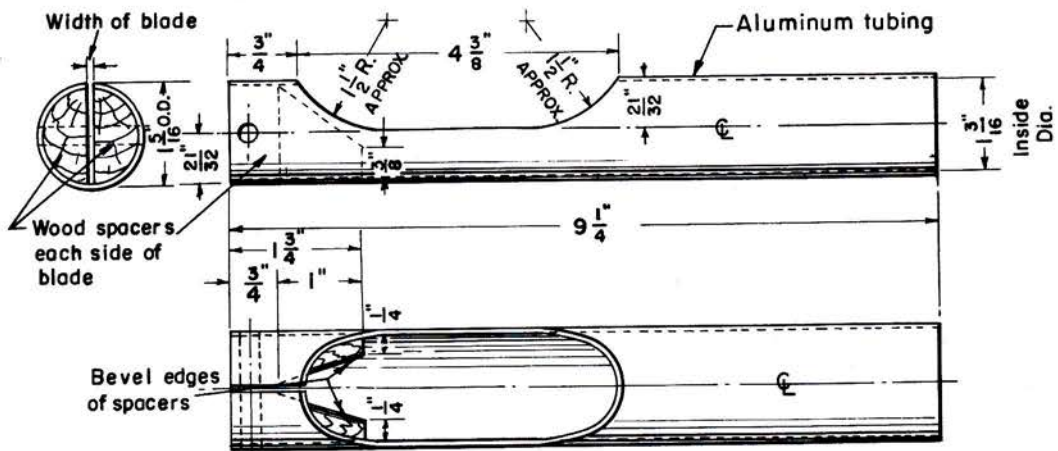

DETAIL OF CONE HOLDER

# A CUTTER FOR SAMPLING CONE SEED QUALITY

Boyd C. Wilson,  
Forest Geneticist,  
Washington State Department of Natural Resources  
Olympia, Wash.

When cones are collected or purchased in the Pacific Northwest, cutting a sample of these cones is standard practice to get an estimate of the number of full seed they contain and therefore the amount of seed likely to be extracted from them as a guide to their worth for collecting or buying.

Cones can be cut by many methods! Sometimes a knife or an axe is used, sometimes sharpened files or saw blades mounted on a base and having a chopping action. A good cutter for field use on Douglas-fir and smaller cones is the Osborne cone cutter described by Hopkins<sup>1</sup> and by Syverson<sup>2</sup>. This cutter is adequate for limited field use, but for cone buying, when 5 to 10 cones are sampled from every sack, a more efficient and less tiring tool is required.

The type of cone cutter presently used by State of Washington, Department of Natural sources, was designed similarly to those used many years by the Manning Seed Co.

This cone cutter (fig. 1) is ideally suited for Douglas-fir, the species of cones most commonly collected. But it has been used to cut cones of practically every species in this region, including ponderosa pine, the true firs, and western hemlock. Cones too big to be cut in one motion, such as noble fir, are cut in two or three.

Although easily portable, the cutter can be fastened to a table or a bench for work in one

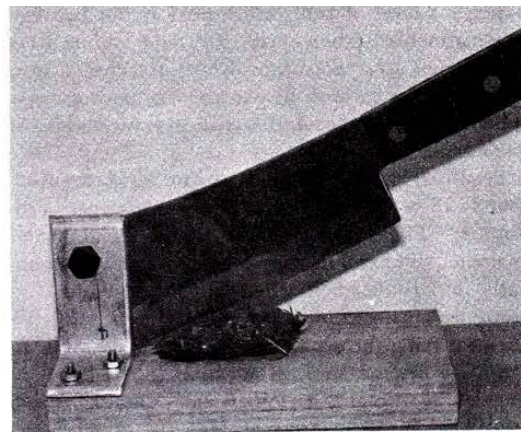

Figure 1. Cone cutter with a Douglas-fir cone in position to be cut.

location. The wide handle provides a broad, comfortable grip for the operator, and is high enough so that he does not rap his knuckles each time he makes a cut. The pivot hole is about 2 inches higher than the blade edge and, as pointed out by Winjum and Johnson,<sup>3</sup> this arrangement gives a forward and slicing movement to the cutting edge rather than a chopping action. This provides a much smoother cut and makes the full seeds easier to see and count.

The cone cutter (see diagram, fig. 2) is constructed of the following materials:

1. *The blade.* The blade of the cone cutter is a small meat cleaver and is about 7 inches long and 2½ inches high. The overall length is 12 inches. The cleavers are manufactured in different sizes. For this reason, the exact location is not shown, and the dimensions of the pivot hole are not given.

2. *The base.* To withstand the repeated cutting action of the blade, the base must be of a very tough material. For this base, oak was used. Although another hardwood could be substituted, softwood lumber or plywood would likely splinter in a short time.

<sup>1</sup> Hopkins, Donald R. The Osborne Tree Cone Cutting Knife. J. Forest.54: 534. 1956.

<sup>2</sup> Syverson, Martin L. Cone Cutter. Tree Planters' Notes 42. 1960.

<sup>3</sup> Winjum, J. K., and Johnson, N. E. A modified-knife cone cutter for Douglas-fir seed studies. J. Forest. 58: 487-488. 1960.

3. *Blade supports.* Two pieces of angle aluminum provide brackets to pivot the cleaver. Each piece is held to the base by two flathead countsunk stove bolts  $1\frac{1}{8}$  inches long and  $\frac{3}{16}$  inch in diameter. The diameter of the bolt holding the cleaver must be matched to the cleaver hole size. The aluminum

angle is used because it is lighter than angle iron and does not rust. All screws and bolts are plated to prevent rusting. Although not absolutely necessary, a nylon or polyethylene washer between each side of the blade and the aluminum bracket will provide smoother action.

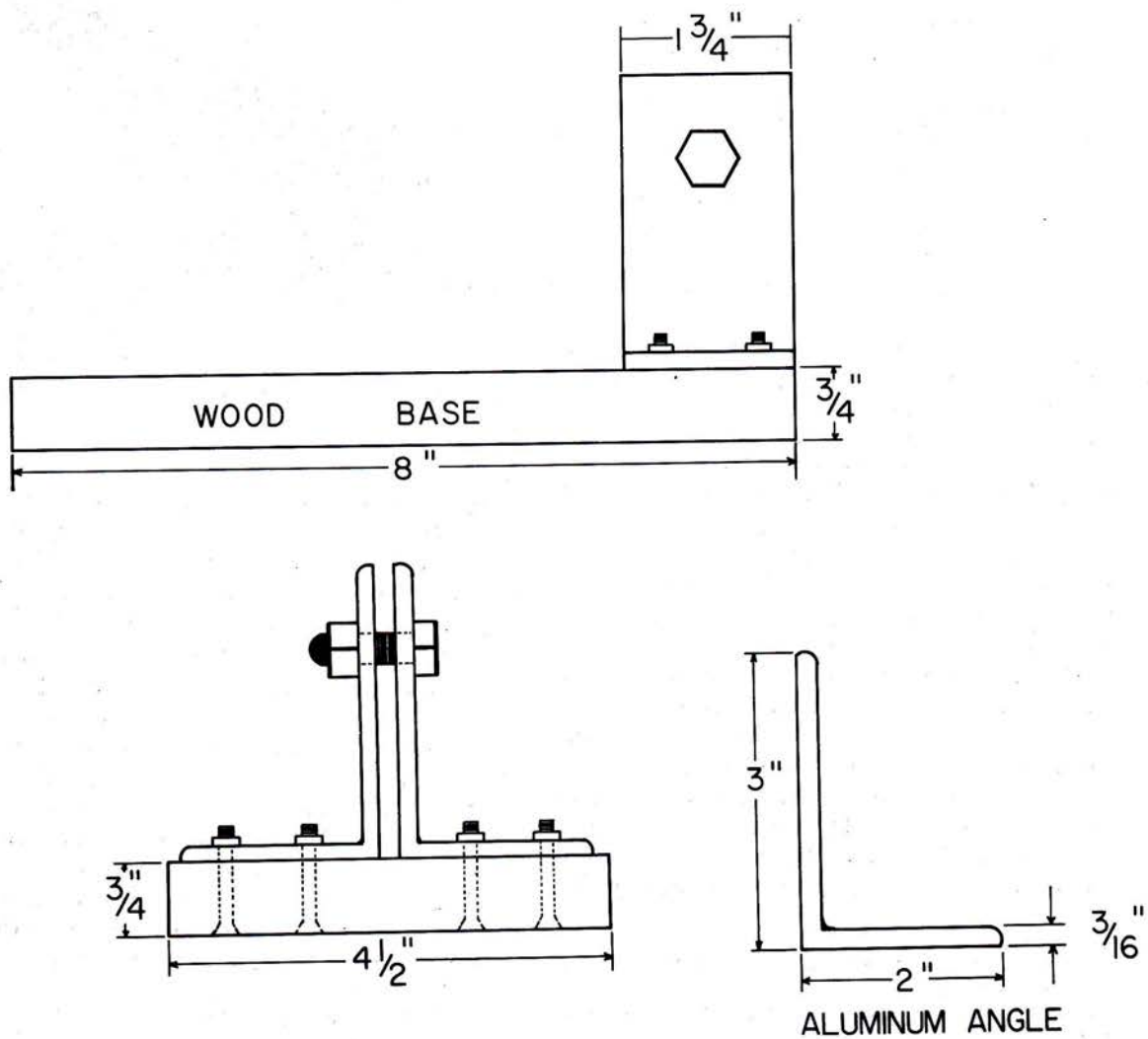

Figure 2.—Diagram of cone cutter base and blade supports.



## A NEW TABLE MODEL CONE CUTTER

GARY L. DEBARR and M. T. PROVEAUX<sup>1</sup>

Foresters and forest entomologists have developed different types of cone cutters that make it easier to evaluate seed crops and to appraise insect-caused seed losses. Hopkins<sup>2</sup> described a portable cone cutter, which consisted of a piece of metal pipe to hold the cones and a knife made from an old saw blade. This lightly constructed cutter was most effective on small cones, such as Douglas-fir and western hemlock. Winjum and Johnson<sup>3</sup> improved the design by using a thin-bladed butcher knife for the cutter and raising the knife fulcrum so that a rolling-slice action was achieved, resulting in smooth, clean sectioning of cones. This cone cutter was used primarily for bisecting green cones of Douglas-fir, grand fir, Pacific silver fir, and ponderosa pine.

We have modified the hand-operated cutters used in the past<sup>4</sup>, but they have not been entirely satisfactory. Because we cut thousands of cones each year for observation, a cutter was needed that would be easy to operate and also split the cones in one cut. By designing a table model cutter with a connecting linkage from the blade to a foot pedal, we increased the mechanical advantage many times.

The table (fig. 1) consists of a 20- by 35-inch top of  $\frac{1}{4}$ -inch steel plate (A), with short stubs (B) of  $\frac{1}{4}$ -inch by  $1\frac{1}{2}$ -inch angle iron welded to the plate at the corners on a  $5^\circ$  angle. Four 30-inch legs (C) of  $\frac{1}{4}$ -inch by  $1\frac{1}{2}$ -inch angle iron are bolted to the stubs with  $\frac{5}{16}$ -by 1-inch bolts, for easy disassembly for storage.

Two end crossmembers (D) of  $\frac{1}{4}$ -inch by 2-inch angle iron are bolted, with the angle to the inside, to the legs with  $\frac{5}{16}$ -by 1-inch bolts. A piece of  $\frac{1}{4}$ -inch by 2- by 2-inch angle iron is welded to the two

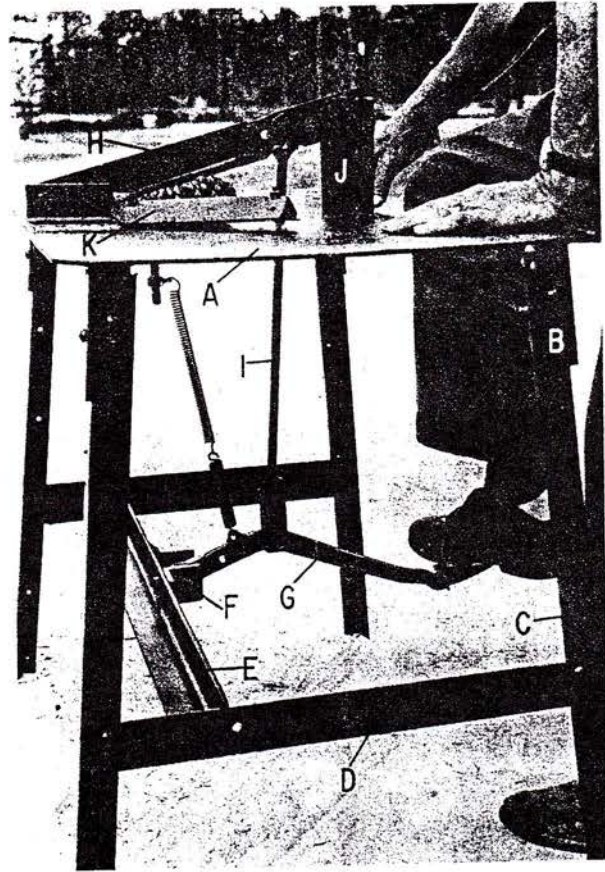

Figure 1.—The component parts of the table model, foot-operated cone cutter: (A) Table top, (B) leg stub, (C) leg, (D) end cross member, (E) pivot support member, (F) pivot pin, (G) foot pedal lever, (H) blade, (I) pull rod, (J) blade guide, and (K) cone guide.

end cross pieces,  $5\frac{1}{2}$  inches from the back side, to form a support member (E) for the foot pedal pivot. The pivot pin (F) is a  $\frac{7}{8}$ -inch round steel rod 3 inches long, welded to a piece of  $\frac{1}{4}$ - by 2- by 2-inch angle iron, which is welded to the foot pedal support member in the center. Another piece of  $\frac{1}{4}$ - by 2- by 2-inch angle iron is drilled to slip over the pivot pin and is bolted to the support member.

We made the foot pedal lever (G) from an old Jeep brake lever. But this can be made from any  $\frac{1}{2}$ -inch by 1-inch steel with a piece of  $\frac{3}{4}$ -inch pipe welded to the end.

<sup>1</sup> Assoc. Entomologist and Instrument Maker, respectively, Southeast. Forest Exp. Sta., Forest Service, NSDA, Obustee, Fla.

<sup>2</sup> Hopkins, D. R. The Osborne tree cone cutting knife. *J. Forest.* 54: 534. 1956.

<sup>3</sup> Winjum, J. K., and Johnson, N. E. A modified-knife cone cutter for Douglas-fir seed studies. *J. Forest* 58: 487-488. 1960.

<sup>4</sup> Southeast. Forest Exp. Sta. Insects destructive to flowers, cones, and seeds of pine. *Annu. Rep.* 1959: 76. 1960.



The 17-inch blade (H) is  $\frac{1}{8}$ - by 2-inch OI S.A.E. oil-hardened steel. A grinding wheel is used to bevel the cutting edge on both sides of the blade, and the final sharpening is done with an oil stone. Two holes are drilled in the blade. The first is a  $\frac{1}{2}$ -inch hole drilled  $\frac{3}{4}$  inch from one end and  $\frac{7}{8}$  inch from the top side. A  $\frac{1}{2}$ - by 1-inch bolt fastens the blade between two  $\frac{1}{4}$ - by 2- by 2- by 4-inch angle iron brackets welded to the rear center of the table top. The holes for this pivot bolt are drilled in the brackets  $1\frac{3}{8}$  inches above the table top. Because the pivot end of the blade is mounted slightly above the table top, the actual cutting edge does not come in direct contact with the table surface.

A second hole is drilled through the blade 12 inches forward from the center of the first one. A bolt through this hole fastens the blade to the pull rod (I), which extends through the table and bolts to the foot pedal lever. The pull rod is a  $\frac{1}{2}$ -inch round steel rod with the blade and foot pedal attachment brackets welded on. Springs fastened to the foot pedal lever at a point 3 inches from the center of the pivot pin, and then attached to a nut and bolt welded to the underside of the table top, return the blade to the up position. Two blade-guide brackets (J) are welded to the table to hold the blade in a straight cut through the cone. These are 6-inch pieces of  $\frac{1}{4}$ - by 2- by 2-inch angle iron.

Two 2- by 2- by 10-inch angle iron guides (K) are used to center the cone under the blade. These are loosely bolted to the table top at one end and swing freely in and out to adjust for different size cones (fig. 2).

This foot-operated, table model cone cutter is much easier to use than the old hand-operated models. Also, because it splits southern pine cones exactly through the axis with one cut, it is very sat-

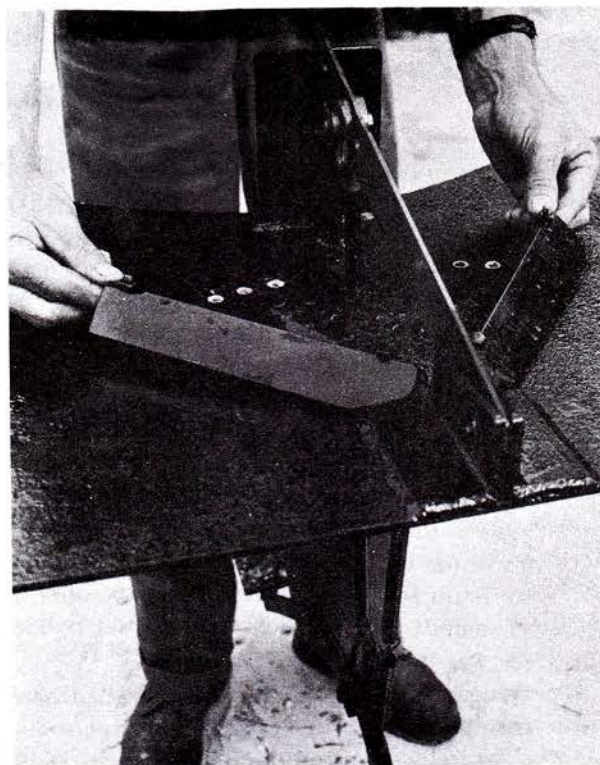

Figure 2.—Adjustable angle-iron guides center the cone under the blade.

isfactory for observing insect infestation and damage. One of our biggest cone-cutting jobs is in late October and November after slash and longleaf cones have matured. Cones are bisected at this time to determine the presence or absence of mature overwintering seedworm larvae in the cone axis. It is very difficult to bisect these dry, opened, mature cones with a clean cut; but after soaking them in water for 4 hours, the cones close and are readily sliced with the foot-operated cone cutter.

