

**FEASIBILITY STUDY OF PALM OIL CLINKER AS
ENVIRONMENTALLY FRIENDLY SELF-COMPACTING
CONCRETE**

JEGATHISH KANADASAN

**FACULTY OF ENGINEERING
UNIVERSITY OF MALAYA
KUALA LUMPUR**

2016

**FEASIBILITY STUDY OF PALM OIL CLINKER AS
ENVIRONMENTALLY FRIENDLY SELF-
COMPACTING CONCRETE**

JEGATHISH KANADASAN

**THESIS SUBMITTED IN FULFILMENT OF THE
REQUIREMENTS FOR THE DEGREE OF DOCTOR OF
PHILOSOPHY**

**FACULTY OF ENGINEERING
UNIVERSITY OF MALAYA
KUALA LUMPUR**

2016

UNIVERSITY OF MALAYA
ORIGINAL LITERARY WORK DECLARATION

Name of Candidate: **Jegathish Kanadasan**

Registration/Matric No: **KHA 110025**

Name of Degree: **Doctor of Philosophy (Ph.D)**

Title of Project Paper/Research Report/Dissertation/Thesis (“this Work”):

Feasibility Study Of Palm Oil Clinker As Environmentally Friendly Self-Compacting Concrete

Field of Study: **Construction Technology & Management (Civil Engineering)**

I do solemnly and sincerely declare that:

- (1) I am the sole author/writer of this Work;
- (2) This Work is original;
- (3) Any use of any work in which copyright exists was done by way of fair dealing and for permitted purposes and any excerpt or extract from, or reference to or reproduction of any copyright work has been disclosed expressly and sufficiently and the title of the Work and its authorship have been acknowledged in this Work;
- (4) I do not have any actual knowledge nor do I ought reasonably to know that the making of this work constitutes an infringement of any copyright work;
- (5) I hereby assign all and every rights in the copyright to this Work to the University of Malaya (“UM”), who henceforth shall be owner of the copyright in this Work and that any reproduction or use in any form or by any means whatsoever is prohibited without the written consent of UM having been first had and obtained;
- (6) I am fully aware that if in the course of making this Work I have infringed any copyright whether intentionally or otherwise, I may be subject to legal action or any other action as may be determined by UM.

Candidate’s Signature

Date:

Subscribed and solemnly declared before,

Witness’s Signature

Date:

Name:

Designation:

ABSTRACT

The environmental problems resulting from a myriad of improper waste management issues have been on the rise for the past few decades. Some of these wastes have a high potential to be converted into usable materials to avoid excessive use of natural resources. In this study, the incorporation of palm oil clinker (POC), a waste from the palm oil mill as a lightweight aggregate for the production of self-compacting concrete (SCC) was researched thoroughly. A complete characterisation study on POC was carried out to understand its physical, chemical and microstructural properties. POC specimens were collected from the respective states throughout Malaysia to identify the variations and the likely causes leading to differences. Since POC is lightweight, porous and irregular in shape, a new mix design methodology was required to accommodate these properties to boost the fresh and hardened SCC properties. Particle packing (PP) concept was developed to suit the special POC characteristics. The void volume and the packing values were analysed and later integrated into a mix proportion. POC powder was introduced instead of using excessive amount of cement to supplement the need for extra paste. Fresh properties of SCC were determined and checked against a normal accepted standard to ensure they comply with the regulated limits. The hardened properties of the concrete were determined through compressive strength, flexural strength, splitting tensile strength and modulus of elasticity. The long-term behaviour of the concrete was investigated through a series of durability tests. As this study focuses on the use of waste material, a sustainability assessment is necessary to highlight the advantages and contributions. This was carried out through a complete greenhouse gas emission study, life cycle assessment, cost efficiency and energy efficiency. Smaller variations in strength and sustainability properties of the POC specimens throughout Malaysia indicate the adaptability of the material to be used in concrete. POC powder, a new material introduced in this study showed significant achievement in strength,

engineering economic index (ECI) and engineering environmental index (EEI) by 71%, 26% and 42% respectively when 50% of cement is replaced. For mass production, POC powder can save about 3.3% of cement for every tonne of crude palm oil produced. Generally, substitution of POC has the ability to produce almost 70% to 78% strength properties of the conventional concrete, making it feasible to be used in construction industry. Sustainable assessment carried out showed that the EEI and ECI for POC concrete were enhanced by 25% and 36% respectively. From durability standpoint, POC showed significant improvement at a longer assessment period indicating the quality of the waste material. Parallel with the principle of ‘research leading towards applications’, two products namely palm oil clinker ornament (POCON) and palm oil clinker drain (POCDRA) were designed and tested for commercial use. POC which is being disposed off without any value definitely would provide a much needed impetus to the construction industry by supplementing quality aggregates and cement alternative. In a nutshell, this research has enabled the successful utilization of POC for the production of SCC.

ABSTRAK

Sejak kebelakangan ini, masalah alam sekitar yang disebabkan oleh pengurusan sisa buangan yang tidak efisien telah meningkat. Sebahagian daripada bahan buangan ini berpotensi tinggi untuk dibangunkan sebagai bahan yang berguna bagi mengurangkan penggunaan berlebihan sumber alam semula jadi. Penyelidikan ini bertujuan untuk membangunkan penggunaan batu hangus minyak sawit atau 'palm oil clinker (POC)' sejenis bahan buangan dari kilang kelapa sawit sebagai konkrit memadat sendiri yang ringan. Kajian pencirian yang lengkap untuk mendapatkan ciri-ciri fizikal, kimia dan mikrostruktur telah dijalankan. Sampel POC dari beberapa lokasi di setiap negeri dalam Malaysia telah di analisa untuk mengenalpasti punca yang menjurus kepada perbezaan tersebut. Oleh kerana POC adalah ringan, berliang dan mempunyai bentuk yang tidak sekata, satu metodologi campuran rekabentuk yang baru diperlukan untuk menampung ciri-ciri tersebut bagi meningkatkan sifat segar dan keras konkrit memadat sendiri. Konsep 'particle packing' atau pembungkusan zarah telah dibangunkan untuk mengatasi masalah tersebut. Jumlah liang konkrit dikenalpasti dan diintegrasikan ke dalam formula campuran. Serbuk POC diperkenalkan bagi menampung keperluan pes tambahan untuk mengelakkan penggunaan simen yang berlebihan. Sifat segar konkrit pemadatan sendiri ini telah diperiksa supaya mematuhi had kawal selia yang ada. Ciri-ciri konkrit keras telah dianalisa melalui kekuatan mampatan, kekuatan lenturan, kekuatan belahan tegangan dan modulus keanjalan. Beberapa ujian ketahanan telah dijalankan untuk menyiasat kebolehan jangka panjang konkrit ini. Oleh kerana penyiasatan ini bertumpukan kepada penggunaan bahan buangan, penilaian kemampuan konkrit adalah penting untuk menyerlahkan keupayaan sebenar konkrit ini. Ini telah dianalisa melalui kajian pelepasan gas rumah hijau, penilaian kitar hayat, kecekapan kos dan penggunaan tenaga efisien. Variasi yang kecil dalam sifat kekuatan dan kemampuan POC diseluruh Malaysia menunjukkan kesesuaian penggunaan bahan

ini dalam konkrit. Serbuk POC yang diperkenalkan baru dalam kajian ini menunjukkan pencapaian yang ketara dari segi kekuatan, indeks kejuruteraan ekonomi (IKE) dan indeks kejuruteraan alam sekitar (IKAS) sebanyak 71%, 26% dan 42% masing-masing apabila 50% simen digantikan. Penggunaan serbuk POC secara besar-besaran boleh menjimatkan sebanyak 3.3% simen bagi setiap ton pengeluaran minyak sawit mentah. Secara umumnya, penggantian POC mempunyai keupayaan untuk menghasilkan sifat kekuatan sebanyak 70% hingga 78% daripada konkrit konvensional sesuai untuk diadaptasikan dalam industri pembinaan. Penilaian lestari mendemonstrasikan peningkatan IKAS dan IKE sebanyak 25% dan 36% masing-masing. Dari sudut ketahanan konkrit, POC telah memaparkan peningkatan kualiti yang ketara walaupun ia adalah sisa buangan. Selari dengan konsep penyelidikan menjurus ke arah aplikasi, dua jenis produk iaitu hiasan pratuang POC dan longkang pratuang POC telah direka dan diuji untuk kegunaan komersial. Sedasawarsa ini, POC yang sedang dilupuskan tanpa sebarang nilai sudah pasti akan menjadi alternatif yang berkualiti tinggi kepada agregat dan simen. Secara tuntasnya, boleh dikonklusikan bahawa kajian ini telah menonjolkan manfaat sebenar POC sebagai agregat dan bahan pengganti simen dalam konkrit memadat sendiri.

ACKNOWLEDGEMENTS

I would like to sincerely thank Professor.Dr.Hashim Abdul Razak for guiding and continuously providing me with the knowledge required to conduct the research successfully besides sharing the excitement of new discoveries. His faith and encouragement kept me steadfast in the process of acquiring the knowledge. Besides that, my profound gratitude to all Professors, Associate Professors, senior lectures and lecturers of Department of Civil Engineering for supporting the research work in every possible way to ensure its successful completion. All staff members of Civil Engineering and Mechanical Engineering Laboratories are thanked sincerely for their assistance rendered. I also deeply appreciate and thankful for the kind contributions by the Malaysian Palm Oil Board (MPOB) and the Sime Darby Research Centre (SDRC) on feasibility studies. All the palm oil mills in Malaysia which contributed substantially by providing research samples are not forgotten for.

Besides that, I am eternally grateful to Dr.Vijaya Subramaniam (MPOB), Dr.Paramanathan Selliah (Param Agricultural Services), Professor.Dr.Sumiani Yusoff (Civil Engineering Department, UM) for assisting me in completing the research work. In addition, undergraduate students namely Ms.Auni Filzah and Mr.Zack Kuan who have contributed significantly for this research work are also thanked and sincerely appreciated. I would like to also express my sincerest gratitude to Mr.Kumar Ellappan for his contribution in proofreading the thesis.

Above all, I would like to thank my dearest family members especially parents Mr.Kanadasan Pachiappan and Mrs.Vijaya Kothandaraman who have been always there for me whenever I faced obstacles due to my nature of work. Their presence and support gave me the strength and courage to overcome the arduous task in completing the thesis successfully.

TABLE OF CONTENTS

Abstract	iii
Abstrak	v
Acknowledgements	vii
Table of Contents	viii
List of Figures	xv
List of Tables	xxiii
List of Symbols and Abbreviations	xxv
List of Appendices	xxviii
CHAPTER 1: INTRODUCTION.....	1
1.1 Background.....	1
1.2 Research Objectives.....	6
1.3 Scope of Research.....	7
1.4 Research Significance.....	8
1.5 Thesis Overview.....	10
CHAPTER 2: LITERATURE REVIEW.....	11
2.1 Introduction.....	11
2.2 Malaysian Palm Oil Industry and their Waste.....	11
2.3 Hardened Properties of Palm Oil Waste Concrete	15
2.3.1 Palm Oil Clinker (POC)	15
2.3.2 Oil Palm Shell (OPS)	16
2.3.3 Palm Oil Fuel Ash (POFA)	17
2.4 Self-Compacting Concrete (SCC)	18
2.5 Mix Design for SCC	19

2.6	Waste Material Consumption in SCC.....	25
2.6.1	Agricultural Industry Waste	26
2.6.2	Manufacturing Industry Waste	27
2.6.3	Plastic Industry Waste	29
2.6.4	Glass Industry Waste	30
2.6.5	Construction and Quarry Industry Waste	30
2.6.6	Outcome of Waste Material Utilisation in SCC	32
2.7	Lightweight Aggregates in Conventional Concrete and SCC	32
2.8	Durability Properties of Conventional Concrete and SCC	34
2.9	Rheological Properties of Self-Compacting Mortar and SCC	37
2.10	Sustainability Assessments	39
2.11	Utilisation of Waste Material for Non-Structural Applications	41
2.12	Knowledge Gap in Palm Oil Waste Utilisation for the Construction Industry	43
CHAPTER 3: METHODOLOGY.....		44
3.1	Material Characterisation Tests	44
3.1.1	Moisture Content of Aggregates	44
3.1.2	Specific Gravity and Water Absorption for Aggregates	45
3.1.3	Aggregate Crushing Value (ACV)	46
3.1.4	Aggregate Impact Value (AIV)	47
3.1.5	X-Ray Fluorescence	48
3.1.6	X-Ray Diffraction.....	49
3.2	Mix Design Development.....	49
3.2.1	Determination of Particle Packing.....	53
3.2.1.1	Phase 1.....	53
3.2.1.2	Phase 2.....	53
3.2.1.3	Phase 3.....	53

3.2.1.3	Phase 4.....	54
3.2.2	Application of Particle Packing (PP) Values for Mix Design.....	55
3.3	Fresh Self-Compacting Concrete (SCC) Properties Test	56
3.3.1	Slump Flow Test	57
3.3.2	V-funnel and T ₅₀₀ Test	58
3.3.3	L-Box Test.....	59
3.3.4	Sieve Segregation Test	61
3.3.5	Rheology of Self-Compacting Concrete (SCC) and Mortar	62
3.4	Hardened Properties of Self-Compacting Concrete	63
3.4.1	Density.....	63
3.4.2	Compressive Strength.....	64
3.4.3	Ultrasonic Pulse Velocity (UPV) test.....	65
3.4.4	Flexural Strength	68
3.4.5	Splitting Tensile Strength.....	69
3.4.6	Modulus of Elasticity	70
3.4.7	Drying Shrinkage	70
3.5	Durability Tests	71
3.5.1	Rapid Chloride Penetration Test (RCPT).....	71
3.5.2	Sulfate Attack	74
3.5.3	Water Absorption	75
3.5.4	Sorptivity Test	76
3.5.5	Elevated Temperature Test.....	78
3.6	Sustainability Assessment.....	79
3.6.1	Cost.....	80
3.6.2	Greenhouse Gas (GHG) Emission.....	81
3.6.3	Life Cycle Assessment	82

CHAPTER 4: MATERIAL CHARACTERISATION	83
4.1 Introduction.....	83
4.2 Material Characterisation.....	83
4.2.1 Aggregate Specific Gravity, Water Absorption and Moisture Content ...	83
4.2.2 POC Microstructural Analysis	85
4.2.3 Particle Size Distribution.....	89
4.2.4 Aggregate Bulk Density	90
4.2.5 Aggregate Crushing Value (ACV)	91
4.2.6 Aggregate Impact Value (AIV).....	93
4.2.7 Characteristics of Cement and POC Powder.....	94
4.3 Classification of Local POC Throughout Malaysia.....	99
4.3.1 Physical and Chemical Properties of POC Throughout Malaysia.....	100
4.3.2 Heavy Metal Analysis for Selected POC State Samples.....	105
4.3.3 Contributory Factors towards Variation in the POC Sample Constituents.....	107
 CHAPTER 5: MECHANICAL, ENGINEERING AND DURABILITY PROPERTIES	 112
5.1 Introduction.....	112
5.2 Assessment of Local Palm Oil Clinker (POC) Aggregates	113
5.2.1 Fresh Properties	113
5.2.2 Density.....	115
5.2.3 Compressive Strength and Structural Efficiency	116
5.2.4 Flexural Strength	118
5.2.5 Microstructural Analysis	119
5.3 Evaluation of POC Powder Self-Compacting Mortar (SCM).....	121
5.3.1 Fresh Properties	123

5.3.2	Rheological Behaviour of Fresh Self-Compacting POC Powder Mortar.....	125
5.3.3	Compressive Strength.....	129
5.3.4	Ultrasonic Pulse Velocity (UPV)	134
5.3.5	Flexural Strength	136
5.3.6	Structural Efficiency.....	137
5.3.7	Microstructural Analysis for POC Powder SCM	138
5.3.8	POC powder SCM Elevated Temperature Test.....	139
5.4	POC Fine SCM.....	141
5.4.1	Fresh Properties	141
5.4.2	Density.....	143
5.4.3	Compressive Strength.....	143
5.4.4	Ultrasonic Pulse Velocity (UPV)	145
5.4.5	Microstructural Properties.....	146
5.5	Palm Oil Clinker (POC) Self-Compacting Concrete (SCC) Properties	149
5.5.1	Palm Oil Clinker (POC) Self-Compacting Concrete Mix Proportion....	149
5.5.2	Fresh SCC Properties Tests	152
5.5.2.1	Slump flow	158
5.5.2.2	V-flow flow time and T_{500} time.....	160
5.5.2.3	Segregation resistance test	162
5.5.2.4	L-box test.....	164
5.5.2.5	Rheological properties of SCC.....	164
5.5.3	Hardened Properties of POC SCC.....	167
5.5.3.1	Density	168
5.5.3.2	Ultrasonic pulse velocity (UPV)	170
5.5.3.3	Compressive strength	174
5.5.3.4	Splitting tensile strength.....	179

5.5.3.5	Flexural strength.....	183
5.5.3.6	Modulus of elasticity.....	187
5.5.3.7	Structural efficiency.....	190
5.5.3.8	Drying shrinkage.....	192
5.5.4	Durability Properties of POC SCC.....	195
5.5.4.1	Sulfate resistance.....	196
5.5.4.2	Elevated temperature analysis.....	197
5.5.4.3	Water absorption.....	202
5.5.4.4	Rapid chloride penetration (RCPT) test.....	205
5.5.4.5	Sorptivity.....	208
5.6	Non-Structural Application of POC for Commercialisation.....	211
5.6.1	Palm Oil Clinker Drain (POCDRA).....	212
5.6.2	Palm Oil Clinker Ornament (POCON).....	213
 CHAPTER 6: SUSTAINABILITY AND ENVIRONMENTAL ASSESSMENT		219
6.1	Introduction.....	219
6.2	Assessment of Local Palm Oil Clinker (POC) Aggregates in Mortar.....	219
6.3	POC Powder Self-Compacting Mortar (SCM).....	221
6.4	POC Fine SCM.....	224
6.5	POC SCC.....	225
6.5.1	Green Building Index (GBI).....	226
6.5.2	Cost Analysis.....	227
6.5.3	Greenhouse Gas (GHG) Emissions.....	230
6.5.4	Energy Efficiency.....	234
6.5.5	Life Cycle Assessment.....	235

CHAPTER 7: CONCLUSIONS.....	238
7.1 Conclusions	238
7.2 Recommendation for Future Study.....	244
7.3 Contribution to the Society.....	244
References	245
List of Publications and Papers Presented	278
Appendix A.....	279
Appendix B	280
Appendix C	281
Appendix D.....	282

University of Malaya

LIST OF FIGURES

Figure 1.1:	Biomass produced by different industries in Malaysia (Adapted from Shuit et al. (2009))	4
Figure 1.2:	Dry weight of oil palm biomass in Malaysia in 2009 (Adapted from Awalludin et al. (2015) and Ng et al. (2012))	4
Figure 1.3:	POC production phase in a palm oil mill (Adapted version) (Sulaiman et al., 2011; Awalludin et al., 2015)	5
Figure 1.4:	Large chunks of POC obtained from the oil palm mill	6
Figure 1.5:	POC fine and POC coarse.....	6
Figure 2.1:	Process operation and product of palm oil mill (Mahlia et al. (2001))..	13
Figure 2.2:	Mass balance of palm oil processing (Adapted from Hambali et al. (2010))	13
Figure 2.3:	Differences between self-compacting concrete (SCC) and conventional concrete (Okamura and Ouchi (2003))	19
Figure 2.4:	Mix design procedure for SCC using packing factor method (Su et al., 2001) (Adapted from (Shi et al., 2015))	20
Figure 2.5:	Mix design procedure based on rheology of paste (Bui et al., 2002) (Adapted from (Shi et al., 2015))	23
Figure 2.6:	Mix design flow for SCC by compressive strength method (Ghazi & Al Jadiri, 2010) (Adapted from (Shi et al., 2015))	24
Figure 3.1:	Aggregate impact value test setup	48
Figure 3.2:	Coating of binders into pores during mixing process.....	50
Figure 3.3:	Flow chart of mix design process	51
Figure 3.4:	Schematic diagram of PP test	54
Figure 3.5:	Particle packing test set-up	54
Figure 3.6:	Mixing procedure for POC SCC	56
Figure 3.7:	Vertical concrete mixer.....	57
Figure 3.8:	Base plate for slump flow test (Source :EFNARC (2005))	58
Figure 3.9:	Dimensions of V-funnel (Source : EFNARC, 2005).....	59

Figure 3.10:	V-funnel test set-up.....	59
Figure 3.11:	Dimensions of L-Box apparatus (Source : EFNARC, 2005)	60
Figure 3.12:	L-box test set-up	61
Figure 3.13:	An ICAR rheometer set-up.....	63
Figure 3.14:	A Brookfield rheometer with Rheo3000 software.....	63
Figure 3.15:	100mm cube gang moulds used in this study	65
Figure 3.16:	Compressive strength test machine	65
Figure 3.17:	‘PUNDIT’ UPV test machine.....	66
Figure 3.18:	UPV test for concrete specimen	67
Figure 3.19:	Flexural strength test machine.....	68
Figure 3.20:	Splitting tensile strength molds (200 mm × 100mm diameter).....	69
Figure 3.21:	Modulus of elasticity molds (150mm × 200mm diameter)	70
Figure 3.22:	Rapid chloride penetration test vacuum pump and dessicator (Adapted from PROOVE’it Instruction and Maintenance Manual).....	73
Figure 3.23:	Rapid chloride penetration test setup (Adapted from PROOVE’it Instruction and Maintenance Manual).....	73
Figure 3.24:	Sulfate curing tank.....	75
Figure 3.25:	Sorptivity test schematic diagram.....	77
Figure 3.26:	Sorptivity test set-up.....	78
Figure 3.27:	A schematic temperature and load histories steady-state temperature tests (Phan and Carino (2000))	79
Figure 4.1:	Coarse aggregates used for casting in this study	84
Figure 4.2:	Fine aggregates used for casting in this study	85
Figure 4.3:	Porous structure on (a)(b) POC fine and (c) POC coarse ; red arrow indicates large porous and green arrows indicates micro voids	87
Figure 4.4:	EDX on (a)(b) POC fine and (c) POC coarse.....	87
Figure 4.5:	POC powder morphology obtained through SEM test.....	88
Figure 4.6:	POC powder particle of irregular shape and structure with EDX	

	results.....	89
Figure 4.7:	Fine aggregates grading curve.....	80
Figure 4.8:	Particle size analysis for POC powder and cement.....	95
Figure 4.9:	X-Ray diffraction (XRD) of POC powder.....	95
Figure 4.10:	Comparison of QXRD between (a) POC, (b) silica fume and (c) fly ash.....	96
Figure 4.11:	Location of palm oil mills selected for POC sampling in Malaysia (Map from www.Mapsof.net).....	100
Figure 4.12:	Aggregate crushing values for various states.....	103
Figure 4.13:	X-Ray diffraction results for all states.....	104
Figure 4.14:	Schematic diagram of a typical power house in palm oil mill (Adapted from Yusoff (2006)).....	108
Figure 4.15:	Overlaid oil palm mill location with soil map (Selangor) (Red dot indicates the GPS location of Selangor palm oil mill).....	110
Figure 4.16:	Overlaid oil palm mill location with soil map (Kelantan) (Red dot indicates the GPS location of Kelantan palm oil mill).....	110
Figure 5.1:	Slump flow values for POC samples from each state in Malaysia.....	114
Figure 5.2:	V-Funnel test results for POC samples from each state in Malaysia.....	115
Figure 5.3:	Variation in density for the samples from each state.....	116
Figure 5.4:	Compressive strength of POC samples from each state in Malaysia ..	117
Figure 5.5:	Structural efficiency for POC samples from each state in Malaysia ...	118
Figure 5.6:	Flexural strength results for POC samples from each state in Malaysia.....	119
Figure 5.7:	Aggregate cement paste interface ; CH=calcium hydroxides, CSH=calcium silicate hydrates.....	121
Figure 5.8:	POC aggregate - cement paste interface.....	121
Figure 5.9:	EDX of POC aggregate - cement paste interface – (a) Spot 1 and (b) Spot 2.....	121
Figure 5.10:	Slump flow results for POC powder mortar.....	124
Figure 5.11:	Relationship between shear rate and viscosity of POC powder SCM.....	126

Figure 5.12:	Relationship between shear stress and shear rate of POC powder SCM.....	126
Figure 5.13:	Correlation between yield stress and slump flow of POC powder SCM.....	128
Figure 5.14:	Correlation between V-funnel flow time and viscosity at 5 rev/s of POC powder SCM.....	129
Figure 5.15:	Evolution of compressive strength of mortars as a function of POC powder content.....	130
Figure 5.16:	Comparison of relative compressive strength between POC powder and OPC-pozzolan mortar mixes (Adapted from (Hewlett, 2003)) ...	131
Figure 5.17:	Relationship between POC powder replacement and compressive strength drop	132
Figure 5.18:	Relationship between cumulative strength difference and POC powder replacement.....	133
Figure 5.19:	Evolution of UPV values as a function of POC powder replacement.....	134
Figure 5.20:	Correlation between UPV values and compressive strength for POC powder specimens.....	136
Figure 5.21:	Relationship between POC powder replacement and flexural strength	137
Figure 5.22:	Structural efficiency of POC powder mortar specimens	138
Figure 5.23:	Aggregate paste interface (a) POC 0 and (b) POC 40	139
Figure 5.24:	Relative strength and mass loss for POC powder samples subjected to elevated temperature.....	140
Figure 5.25:	UPV for POC powder samples subjected to elevated temperature	141
Figure 5.26:	Slump flow values of POC fine SCM.....	142
Figure 5.27:	Density of POC fine SCM specimens (Horizontal dashed line indicates the boundary of lightweight mortar).....	143
Figure 5.28:	Evolution of compressive strength of mortars as a function of POC fine content.....	145
Figure 5.29:	Correlation between compressive strength and density for POC fine SCM specimens	145
Figure 5.30:	Effect of POC fine addition on UPV values for POC fine SCM specimens.....	146
Figure 5.31:	(a) Microstructural properties of POC fine (POC 100) and (b)	

	EDX of Spot 3	148
Figure 5.32:	Presence of substantial amount of voids on POC fine aggregates in mortar (as indicated by the red arrows)	148
Figure 5.33:	POC fine-cement paste interface	148
Figure 5.34:	Particle packing for 0.6 F/A mixes	150
Figure 5.35:	Particle packing for 0.5 F/A mixes	151
Figure 5.36:	Properties of SCC for various types of application based on Walraven (2003) (Adapted from EFNARC (2005))(Red mark indicates the selected region)	153
Figure 5.37:	Effect of CLF values on slump flow diameter	155
Figure 5.38:	Effect of CLF values on V-funnel flow time	155
Figure 5.39:	Slump flow values for 0.6 F/A POC SCC	159
Figure 5.40:	Slump flow values for 0.5 F/A POC SCC	160
Figure 5.41:	Effect of paste volume on the slump flow values of POC SCC	160
Figure 5.42:	V-funnel flow time and T_{500} time for 0.6 F/A POC SCC	161
Figure 5.43:	V-funnel flow time and T_{500} time for 0.5 F/A POC SCC	162
Figure 5.44:	Segregation resistance (0.6 F/A)	163
Figure 5.45:	Segregation resistance (0.5 F/A)	163
Figure 5.46:	Correlation between slump flow and yield stress for 0.6 F/A mixes ..	165
Figure 5.47:	Correlation between slump flow and yield stress for 0.5 F/A mixes ..	166
Figure 5.48:	Correlation between V-funnel flow time and viscosity for 0.6 F/A mixes	167
Figure 5.49:	Correlation between V-funnel flow time and viscosity for 0.5 F/A mixes	167
Figure 5.50:	Relationship between density and POC replacement (0.6 F/A)	169
Figure 5.51:	Relationship between density and POC replacement (0.5 F/A)	170
Figure 5.52:	Correlation between density and particle packing of all POC mixes ..	170
Figure 5.53:	Effect of POC replacement on UPV values (0.6 F/A)	171
Figure 5.54:	Effect of POC replacement on UPV values (0.5 F/A)	172
Figure 5.55:	Correlation between particle packing and UPV values of POC SCC mixes (28 days)	173

Figure 5.56:	Correlation between density and UPV values of POC SCC mixes (28 days).....	174
Figure 5.57:	Effect of POC replacement on compressive strength (0.6 F/A).....	175
Figure 5.58:	Effect of POC replacement on compressive strength (0.5 F/A).....	175
Figure 5.59:	Correlation between compressive strength and UPV values.....	178
Figure 5.60:	Effect of POC replacement on splitting tensile strength (0.6 F/A).....	180
Figure 5.61:	Effect of POC replacement on splitting tensile strength (0.5 F/A).....	180
Figure 5.62:	Relationship between splitting tensile strength and compressive strength at 28 days (0.6 F/A).....	181
Figure 5.63:	Relationship between splitting tensile strength and compressive strength at 28 days (0.5 F/A).....	181
Figure 5.64:	Comparison of crack pattern between normal weight concrete and lightweight concrete (Dhir, 1999).....	182
Figure 5.65:	Splitting tensile failure zone (horizontal view) on POC 100 specimen.....	183
Figure 5.66:	Effect of POC replacement on flexural strength (0.6 F/A).....	184
Figure 5.67:	Effect of POC replacement on flexural strength (0.5 F/A).....	184
Figure 5.68:	Relationship between compressive strength and flexural strength (0.6 F/A).....	186
Figure 5.69:	Relationship between splitting tensile strength and flexural strength (0.6 F/A).....	186
Figure 5.70:	Relationship between compressive strength, flexural strength and splitting tensile strength.....	187
Figure 5.71:	Failure mode for POC 0 (control) and POC 100 (side view).....	187
Figure 5.72:	Relationship between modulus of elasticity and POC replacement (0.6 F/A).....	189
Figure 5.73:	Relationship between modulus of elasticity and POC replacement (0.5 F/A).....	190
Figure 5.74:	Correlation between particle packing and modulus of elasticity of POC SCC.....	190
Figure 5.75:	Structural efficiency of POC mixes (0.6 F/A).....	192
Figure 5.76:	Structural efficiency of POC mixes (0.5 F/A).....	192
Figure 5.77:	Relationship between shrinkage and POC replacement (0.6 F/A).....	194

Figure 5.78:	Relationship between shrinkage and POC replacement (0.5 F/A)	195
Figure 5.79:	Correlation between shrinkage and POC replacement (180 Days)	195
Figure 5.80:	Relative strength of POC SCC specimens subjected to sulfate attack.....	197
Figure 5.81:	Compressive strength and mass loss at elevated temperatures for different POC replacement.....	201
Figure 5.82:	Color change between POC 0 and POC 100 specimens.....	201
Figure 5.83:	Structural efficiency of concrete specimens subjected to different temperature regimes (0.6 F/A).....	202
Figure 5.84:	Relative normal strength of concrete under different temperature regimes (0.6 F/A).....	202
Figure 5.85:	Water absorption for 0.6 F/A POC SCC	204
Figure 5.86:	Water absorption for 0.5 F/A POC SCC	204
Figure 5.87:	Rapid chloride penetration test (0.6 F/A)	207
Figure 5.88:	Rapid chloride penetration test (0.5 F/A)	208
Figure 5.89:	Sorptivity values for 0.6 F/A mixes at different replacement levels ...	209
Figure 5.90:	Sorptivity values for 0.5 F/A mixes at different replacement levels ...	210
Figure 5.91:	A POCDRA sample.....	213
Figure 5.92:	A POCON sample.....	214
Figure 5.93:	POCON mortar compressive strength	215
Figure 5.94:	Relationship between compressive extension and compressive load	217
Figure 5.95:	Correlation between POCON compressive strength and POCON maximum load (180 Days)	218
Figure 5.96:	Relationship between POCON structural efficiency and compressive load for different mixes (180 Days).....	218
Figure 6.1:	Cost of mortar incorporating local POC aggregate (RM/L).....	220
Figure 6.2:	Relationship between carbon emission, mix type and engineering environmental index (EEI)	221
Figure 6.3:	Cost comparison of specimens incorporating POC powder with engineering economic index (ECI).....	222
Figure 6.4:	Carbon emissions of specimens incorporating POC powder with	

	engineering environmental index (EEI).....	223
Figure 6.5:	Relationship between engineering economic index (ECI) and engineering environmental index (EEI) for POC powder specimens .	223
Figure 6.6:	Relationship between cost, POC fine replacement and engineering economic index (ECI).....	224
Figure 6.7:	Effect of POC fine addition on carbon emission and engineering environmental index (EEI)	225
Figure 6.8:	Relationship among the cost of concrete, POC replacement ratio and engineering economic index (ECI) (0.6 F/A)	228
Figure 6.9:	Relationship among the cost of concrete, POC replacement ratio and engineering economic index (ECI) (0.5 F/A).....	229
Figure 6.10:	Relationship among the carbon emission, POC replacement ratio and engineering environmental index (per kilometer) (0.6 F/A).....	232
Figure 6.11:	Relationship among the carbon emission, POC replacement ratio and engineering environmental index (per kilometer) (0.5 F/A).....	232
Figure 6.12:	Correlation between carbon emission and cost	234
Figure 6.13:	Comparison of weighted LCIA for 1 ton CPO when POC was used for land application versus when used in the construction industry	237

LIST OF TABLES

Table 2.1:	Major oil crops and production capacity in the world (Basiron, 2007; Johari et al., 2015).....	12
Table 2.2:	Number of palm oil processing sectors in Malaysia (Adapted from (MPOB, 2015)).....	14
Table 2.3:	Oil palm planted areas and fresh fruit bunch (FFB) yield (MPOB, 2015).....	15
Table 2.4:	Summary of SCC mix design comparison.....	25
Table 2.5:	Global carbon emissions from cement production (Ali et al., 2011).....	40
Table 2.6:	Comparison of wastes in concrete	42
Table 3.1:	Ratio of aggregate combinations for PP determination	52
Table 3.2:	Slump flow classes (Source : EFNARC (2005))	58
Table 3.3:	Viscosity classes (Source : EFNARC (2005))	59
Table 3.4:	Passing Ability classes (Source : EFNARC (2005)).....	60
Table 3.5:	Sieve Segregation Classes (Source : EFNARC (2005))	62
Table 3.6:	Classification of the ultrasonic pulse velocities (Anon, 1979)	67
Table 3.7:	Concrete classification based on UPV values (V. M. Malhotra, 1976).....	67
Table 3.8:	Chloride ion permeability based on charges passing (ASTM C1202, 2012)	74
Table 3.9:	Cost of materials by weight (RM/kg)	81
Table 4.1:	Physical properties of POC coarse (coarse aggregate)	84
Table 4.2:	Physical properties of gravel (coarse aggregate)	84
Table 4.3:	Physical properties of fine aggregates	85
Table 4.4:	Bulk density of aggregates used in this study	91
Table 4.5:	Aggregate crushing values of coarse aggregates	92
Table 4.6:	Ten Per Cent Fines Value of coarse aggregates.....	92

Table 4.7:	Aggregate impact values of coarse aggregates	93
Table 4.8:	Chemical and physical properties of binders	98
Table 4.9:	Guidelines for autoclave expansion due to MgO in cement	99
Table 4.10:	ASTM C618 (2015) Class N requirements.....	99
Table 4.11:	Physical characteristics of POC from various sources.....	102
Table 4.12:	Chemical composition of the POC samples from different states	103
Table 4.13:	Heavy metal analysis comparison with standards.....	106
Table 4.14:	Soil types of each state in Malaysia	111
Table 5.1:	Mix proportion for feasibility study	114
Table 5.2:	Mix proportion for self-compacting POC powder mortar	123
Table 5.3:	Particle size distribution of cement and POC powder.	132
Table 5.4:	Mix proportion for POC fine SCM	142
Table 5.5:	Mix proportion for 0.6 F/A	151
Table 5.6:	Mix proportion for 0.5 F/A	152
Table 5.7:	Mix proportion for POCDRA and POCON	212
Table 5.8:	Strength results for POCON samples.....	216
Table 6.1:	POC contribution towards green building index (GBI) assessment	227
Table 6.2:	Mix design comparisons	230

LIST OF SYMBOLS AND ABBREVIATIONS

ACV	:	Aggregate crushing value
AIV	:	Aggregate impact value
ASR	:	Alkali silica reaction
BET	:	Brunauer, Emmett and Teller
BRHA	:	Black rice husk ash
COD	:	Chemical oxygen demand
CPO	:	Crude palm oil
DEM	:	Discrete element method
DMDA	:	Densified mixture design algorithm
ECI	:	Engineering economic index
EDX	:	Energy dispersive X-ray
EEL	:	Engineering environmental index
EFB	:	Empty fruit bunch
EVA	:	Ethylene vinyl acetate
FBA	:	Furnace bottom ash
FFB	:	Fresh fruit bunch
GP	:	Granite powder
GBI	:	Green building index
GHG	:	Greenhouse gas emission
GGBS	:	Ground granulated blast furnace slag
HRWR	:	High range water reducer
ITZ	:	Interfacial transition zone
LCA	:	Life cycle assessment
LCD	:	Liquid crystal device

LCIA	:	Life cycle inventory assessment
LECA	:	Lightweight expanded clay aggregate
LSP	:	Limestone powder
MPOB	:	Malaysian palm oil board
NML	:	Normal
NWC	:	Normal weight concrete
OPF	:	Oil palm fiber
OPC	:	Ordinary Portland cement
OPS	:	Oil palm shell
PD	:	Packing density
PF	:	Packing factor
PP	:	Particle packing
PP	:	Polypropylene
PBC	:	Pulverized burnt clay
PET	:	Polyethylene terephthalate
PFA	:	Pulverised fly ash
PFAD	:	Palm fatty acid distillate
PKM	:	Palm kernel meal
PKO	:	Palm kernel oil
POC	:	Palm oil clinker
PUR	:	Polyurethane
POFA	:	Palm oil fuel ash
POME	:	Palm oil mill effluent
PBWF	:	Plastic bag waste fibers
RHA	:	Rice husk ash
RBDPL	:	Refined palm olein

RBDPO	:	Refined bleached deodorized palm oil
RBDPS	:	Refined bleached deodorized palm oil stearine
RCPT	:	Rapid chloride penetration test
SE	:	Structural efficiency
SP	:	Superplasticizer
SCC	:	Self-compacting concrete
SCM	:	Self-compacting mortar
SEM	:	Scanning electron microscopy
SSD	:	Saturated surface dry
SCLC	:	Self-compacting lightweight concrete
UPV	:	Ultrasonic pulse velocity
VMA	:	Viscosity modifying admixture
W/B	:	Water binder

University of Malaya

LIST OF APPENDICES

Appendix A: Mix design procedure.....	279
Appendix B: Malaysian soil classification (soil taxonomy)	284
Appendix C: Overlay of palm oil mill GPS on soil map	285
Appendix D: Experimental photos.....	286

University of Malaya

CHAPTER 1: INTRODUCTION

1.1 Background

Construction industry and environmental management system has undergone major development over the years throughout the world. Unfortunately, development of construction industry and the environmental management have resulted in escalating usage of unsustainable raw materials and continuous generation of the waste from various sources, respectively. Thus, the need for good coherence between these two entities has been a major focus for most if not all the engineers and scientists to ensure safer living and appropriate atmosphere for current and future generations. Management of waste materials from major processing and production plants be it from agricultural industry, food industry, metal industry, power plant, waste treatment plant or others into a proper channel is of the utmost important to avoid serious environmental catastrophe. In tandem with that, re-usage of waste materials in construction industry would be a way of managing the waste appropriately. Construction industry would benefit greatly from the inclusion of these waste materials taking into account the reduction in availability of natural resources to supplement the increasing need. These waste materials could pave a better way to avoid excessive utilisation of natural resources for use as construction materials. Among the avenues of the waste materials to be incorporated into the construction industry is in the concrete mixture.

Traditionally, conventional vibrated concrete has been the popular type of concrete over many decades in the construction industry until the need for different performance and application were required. Subsequently, the industry moved towards high and ultra-performance concrete to supplement the constantly changing industry. Self-compacting concrete (SCC), a latest advancement in concrete has become one of the most important elements in construction industry lately. Generally, SCC can be

described as a concrete that has the ability to flow under its own weight without the need of any external vibration. Besides that, the enhancement made through introduction of extra powder materials to make it highly flowable and fill up voids has improved its capability to produce quality concrete with good surface finishing, improved hardened properties and enhanced durability features. SCC usage has been diversified to construct various components of building structure such as beams, columns, slabs and also the precast concrete elements. As the concrete has the capability to consolidate on its own, the need for labourers to vibrate and place the concrete can be significantly reduced. The fast casting process speeds up the overall project schedule to allow for earlier completion. It is also proven to be economically viable as the cost of construction could be decreased substantially due to reduced labour requirements and shorten construction time (Daczko, 2012). Next, the ability of SCC to fill areas of congested reinforcements and adjust according to different shapes and sizes of molds allows for detailed and fine structural designs. In addition, designs which were thought to be architecturally challenging and technically impossible were made possible.

The use of waste materials in SCC would be an interesting area to be explored. The abundantly available waste materials can be utilised in concrete as a replacement for aggregates, cement, binder or filler materials to achieve industrial ecology. An 'industrial ecology' is a practice which substitutes the natural materials with a by-product of an industry (Mehta, 2002). Excessive use of natural resources could be significantly reduced to ensure its sustainability for future needs. In most of the cases, this method does pave the way for systematic waste treatment and disposal method to avoid serious environmental pollutions. As some of the wastes require another piece of land or location and expensive mode of disposal, utilisation of this waste in the construction industry indeed fosters economically viable and safer disposal. In line with global push towards the '3R' concept which integrates recycling, reducing and reusing

principle, channelling this waste into construction industry would be a smart and ideal way.

The deteriorating environmental problems have become a major topic of interest currently. Agricultural or plantation industry has been the backbone of Malaysia for the past few decades. Thousands of hectares are planted with oil palm, rubber, paddy, cocoa, coconut, sugar cane, herbs, fruits and others. Despite getting valuable goods at the end of processing stages, equal amounts of waste are also generated which needs to be dumped appropriately. If these wastes are deposited without proper treatment or management system, it will lead to serious environmental catastrophe which could harm health of living things. In turn, consuming these waste materials in construction industry will be a good and ideal method to reduce environmental pollution besides ensuring sustainability of materials. Malaysia is one of the producers and exporters of palm oil products. The tropical location of Malaysia and Indonesia makes these countries suitable for growing oil palm (*Elaeis Guineensis*) (Loh et al., 2013). The first oil palm plantation estate was established in Tennamaram Estate, Selangor which was used for commercial purpose (Abdullah & Sulaiman, 2013). Figure 1.1 shows the biomass produced by different industries in Malaysia. As observed, palm oil industry contributes around 85.5% to the overall biomass produced in Malaysia. It was reported that almost 80 million tonnes of dry solid biomass waste was discharged from the palm oil industry annually and the value is expected to increase to 85-110 million tonnes by 2020 (A. I. Malaysia, 2011). One hectare of palm oil plantation has the ability to provide between 10 tonnes and 35 tonnes of fresh fruit bunch (FFB) annually (Igwe & Onyegbado, 2007). In May 2015, the overall FFB received by the palm oil mills in Malaysia was approximately 9 million tones (MPOB, 2015). Palm oil processing generates various types of waste that have the potential to be utilised in other industries. These include palm oil clinker (POC), palm oil fuel ash (POFA), oil palm shell (OPS), empty fruit

bunch (EFB), palm oil mill effluent (POME) and oil palm fibres (OPF). Figure 1.2 depicts the percentage weight of dry biomass discharged from a palm oil mill. The waste discharge is also prone to cause environmental problems to the nature through air, water and soil pollution (Loh et al., 2013).

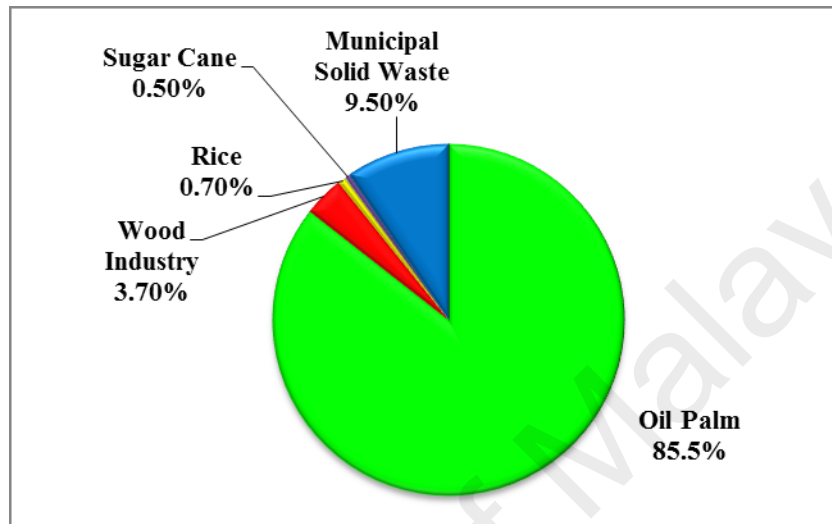

Figure 1.1: Biomass produced by different industries in Malaysia (Adapted from Shuit et al. (2009))

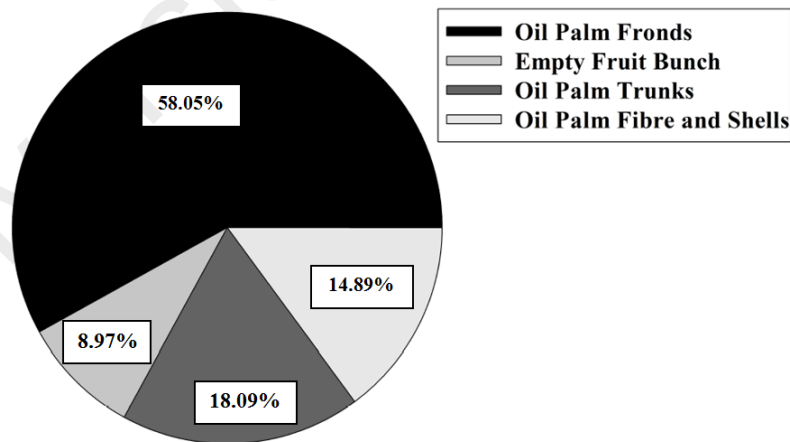

Figure 1.2: Dry weight of oil palm biomass in Malaysia in 2009 (Adapted from Awalludin et al. (2015) and Ng et al. (2012))

As the fibers and shells possess a huge amount of calorific value, they are used to produce steam and electricity for mill consumption (Hansen & Nygaard, 2014). It is also reported that fibers and shells are utilised as boiler fuel to avoid pollution problems arising from the improper disposal of this waste (Mahlia et al., 2001; Harimi et al., 2005). On the other hand, POC is a waste from the incineration process of mesocarp fiber and OPS. Figure 1.3 shows the processes involved in a palm oil mill to produce POC. After the incineration process at high temperature, they turn into hardened state with immense amount of pores on the surface due to the pyrolysis process. Moreover, the lower bulk density of POC compared to natural aggregates makes them suitable for production of concrete with lower density.

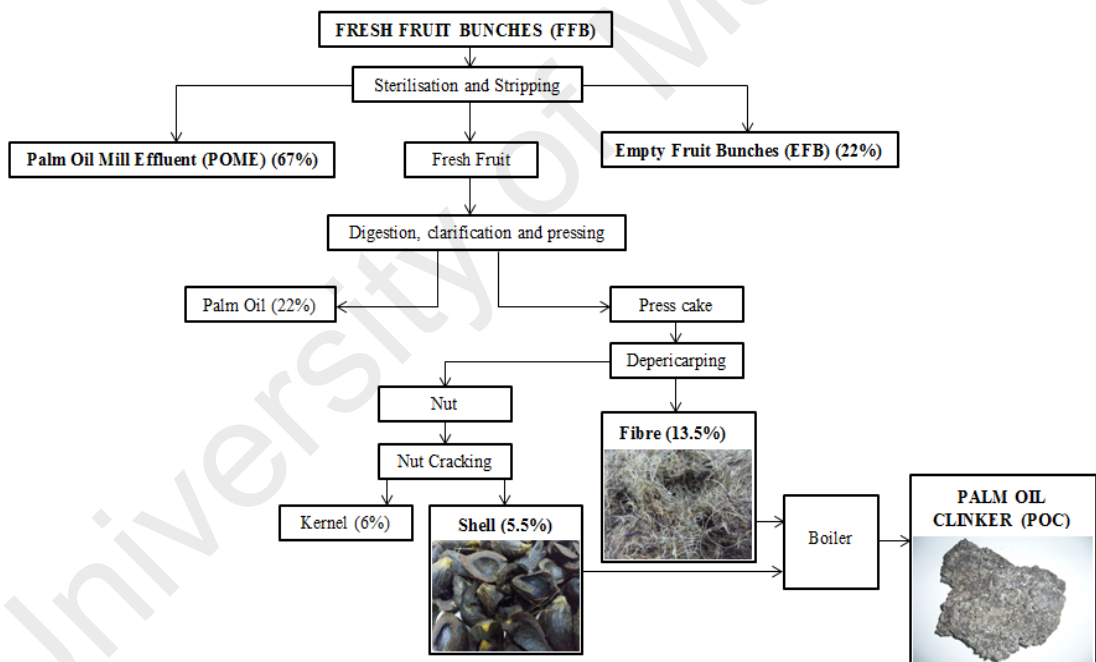

Figure 1.3: POC production phase in a palm oil mill (Adapted version)(Sulaiman et al., 2011; Awalludin et al., 2015)

Figure 1.4 shows large chunks of POC aggregates obtained from the oil palm processing mill. The size of the chunks varies between 5 and 400 mm. They could be crushed in the laboratory to provide the required aggregate size for consumption in concrete. Figure 1.5 shows POC coarse and POC fine which are prepared in the laboratory. In addition to that, POC was also ground into fine powder to produce palm

oil clinker powder of size less than 300 microns to satisfy the need for additional paste volume.

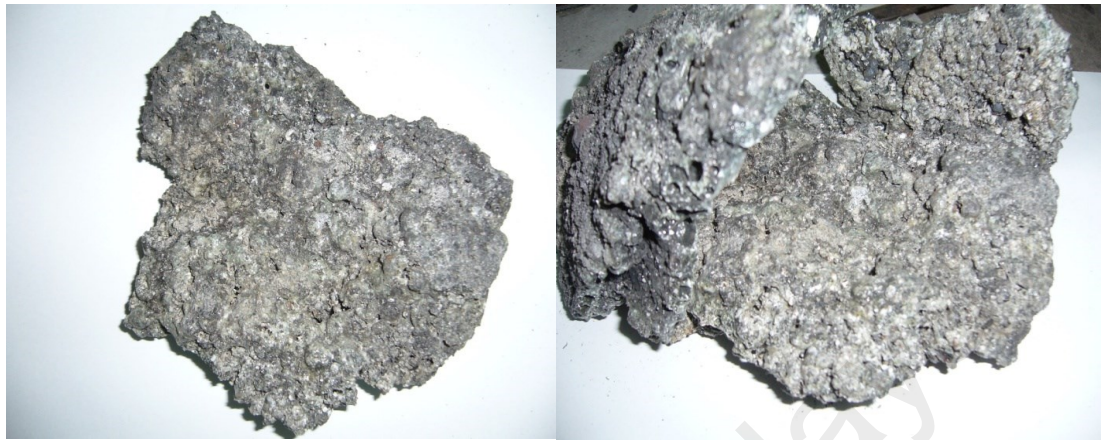

Figure 1.4: Large chunks of POC obtained from the oil palm mill

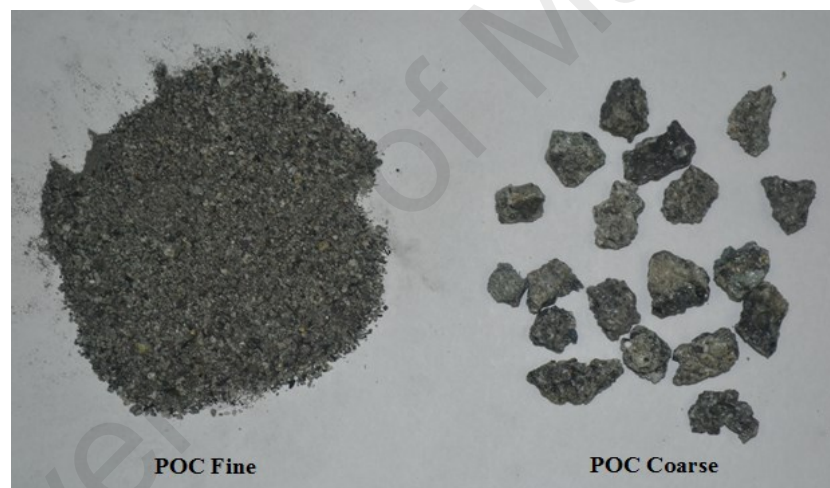

Figure 1.5: POC fine and POC coarse

1.2 Research Objectives

The objectives were planned and carried out by taking into consideration the complete properties of using POC as aggregates and filler materials in concrete as it would be the pioneering work. The objectives of this study are,

- 1) To identify the characteristics of POC from various locations in Malaysia and determine its variations and possible ways to adapt them in concrete.
- 2) To develop and propose a new mix design methodology incorporating particle packing (PP) concept for generally porous and lightweight concrete.

- 3) To study the mechanical and engineering properties of POC self-compacting mortar (SCM), POC fine SCM and POC SCC developed and propose a suitable application for utilising them in construction industry. Cost efficiency, environmental impacts and sustainability performance were also evaluated to study the positive contribution.
- 4) To investigate the long term and durability properties of selected POC SCC.
- 5) To develop and test prototype building components incorporating POC to promote low cost construction.

1.3 Scope of Research

The study is mainly focussed on achieving SCC using waste material from the palm oil industry. POC, a by-product from the oil palm incineration process will be utilised as aggregates as well as filler in the production of SCC. Generally, the study can be divided into 3 phases. The first phase deals with study on the literature reviews and material characterisations. Past and currently available research works on ordinary SCC and waste materials consumption in SCC were given focus. POC and other materials to be consumed in SCC are experimented for their properties to ensure effectiveness in the mix design process. One of the vital parts is to assess the feasibility or properties of POC samples from all over Malaysia. POC samples were collected from every state in Malaysia including Sabah and Sarawak. This is vital in order to evaluate the differences in the physical and chemical properties of POC which will vary according to type of soil, weather, and fertilizers. The data will serve as a guide for further research in terms of attainment of fresh and hardened properties.

The second phase involves study on the SCC mix design methods available as well as changes to suit the waste material usage. Despite having few types of mix design methods for SCC, it is still in need of proper and consistent mix design process which

integrates the material properties especially for the waste material. Hence, a new mix design process taking into consideration the PP concept was integrated into this study to optimize the right combination of aggregates and paste volume. Adjustments were made in mix proportioning method to cater for the utilisation of waste material and most importantly satisfying SCC characteristics. Rheological studies on concrete and mortar were carried out during this stage to ascertain the basic direct properties of SCC and self-compacting mortar (SCM) such as viscosity and yield stress. In addition, a pioneer study was carried out on the performance of POC powder and POC fine as supplementary research works to support the major study. It is a vital part of the study as it provides correlation between the particle properties and mix design procedure adapted. Engineering and mechanical properties of concretes incorporating POC were evaluated to establish various relationships. The long term behaviour of the concrete was established through durability studies. It gives further benefit to the utilisation of the waste materials in the construction industry. The third phase involves assessing the 'green' components of this waste material through environmental and sustainability aspects. Sustainability and environmental components were assessed via a complete review on economic, energy efficiency, greenhouse gas emissions and life-cycle assessment. Lastly, two products using high volume of POC as major components were developed to suit the low cost housing scheme thus promoting direct use of POC for construction purposes.

1.4 Research Significance

Environmental pollution and sustainability of the construction industry were the major considerations for initiating this research. With the environment pollutions escalating due to a myriad of reasons, recycling waste materials would be an ideal choice to overcome them. Waste from agricultural industry not only worsens the pollution problem but also increases the demand for landfill plots. Land that is utilised

for waste disposal may not be useful for crops and plants due to lack of nutrients and high impurity level. The varying nature of agricultural waste may greatly affect the soil condition and their nutrient structures to reduce the chances of replantation and further crop growth. Economically, the revenue expected from the plantation may decline over a longer period of time. Besides that, land filling these wastes could cause leachates which can harm living things. Natural habitats for soil life may also be destroyed in certain ways that would result in environmental issues. The groundwater table may be also polluted due to excessive landfilling over ground water catchment area. Hence, experimenting ways to reuse or recycle wastes from various sources will help to lessen these problems.

Sustainability of the construction industry is a major current issue that needs to be addressed. The usage of gravel and sand which are the major constituents of a concrete has to be reduced to ensure sustainability. Hence, utilisation of these waste products which has good capability and enhanced properties could well serve as a supplementary material to support the construction industry. The misconception of SCC being expensive based on the cost of materials which is usually regarded as a disadvantage was tackled in this study to support the idea of constructing a cheap and affordable house for the lower income group (Naik et al., 2012). The novelty of the research which involves incorporation of POC as aggregates and filler material in SCC could benefit the construction industry in the long run. The unique 'selling point' of this research will be focussed mainly on the utilisation of a completely waste material from the palm oil mill as aggregates and powder materials for the production of SCC. This would be the first comprehensive study carried out on POC as aggregates and filler material in concrete.

1.5 Thesis overview

Chapter 1 introduces the main concept of the thesis together with the objectives and scope of research. Chapter 2 highlights the literature review works done in the past focusing on the agricultural industry, use of waste material and sustainability components. Meanwhile, chapter 3 discusses the methodology and experimental programmed used throughout the research. Chapter 4 outlines the characterization of the aggregates and powder materials incorporated in this study. Chapter 5 provides the results and discussions of the overall outcome of the study. The sustainability and environmental assessments are included in Chapter 6. Lastly, Chapter 7 summarizes the content of the thesis.

University of Malaya

CHAPTER 2: LITERATURE REVIEW

2.1 Introduction

Studies were carried out on the utilisation of waste materials, self-compacting concrete (SCC), Malaysian palm oil industry, engineering and mechanical properties of ordinary and lightweight concrete, durability features of lightweight concrete, mix design modifications to suit SCC and rheological behaviour of self-compacting mortar (SCM) and concrete. These aspects were important to detail out the required scope of study for this research.

2.2 Malaysian Palm Oil Industry and their Waste

The palm oil industry in Malaysia has developed progressively over the years with substantial production of oil palm based products and refineries. Oil palm has become the main type of oil production crops in the world compared to other minority oil production plants. Table 2.1 shows the major oil crops and their production capacity in the world (Basiron, 2007; Johari et al., 2015). A report from Malaysia Palm Oil Board (MPOB) indicates that in 2013, 5.23 million hectares of land in Malaysia was planted with oil palm which was 3% higher than in 2012. This suggests a possible direct proportional relationship to the increase in total oil palm products. Researchers also reported that in 2014 the palm oil export was estimated about RM63.6 billion which is around 9% of the total exports of Malaysia (Sundram et al., 2015). As of July 2014, in Peninsular Malaysia, Sabah and Sarawak there are 440 fresh fruit bunch (FFB) mills (MPOB, 2014). Aforementioned, out of these 440 mills, 247 are located in Peninsular Malaysia and remaining are in Sabah and Sarawak respectively. Halimah et al. (2013) reported that a total of 18.7 million tonnes of crude palm oil were produced.

Table 2.1: Major oil crops and production capacity in the world (Basiron, 2007; Johari et al., 2015)

Oil seed crop	Oil production (million tonnes)	Area cultivated (million hectares)	Total production (%)	Average oil yield (tonnes/hectare/yr)
Palm oil	33.73	9.17	31.84	3.68
Soy bean	33.58	92.10	31.69	0.36
Sun flower	9.66	22.90	9.12	0.42
Rapeseed	16.21	27.30	15.30	0.59

Figure 2.1 shows the process operation and product of an oil palm mill. Meanwhile, Figure 2.2 shows the mass balance of an oil palm processing. As seen in Figure 2.2, there are a number of by-products being produced during the processing stages of crude palm oil. Some of the by-products like sludge, oil palm shell (OPS), oil palm fibre (OPF) and palm oil clinker (POC) are considered as waste materials. It is evidently seen that FFB contains the highest portion of fruits which produces about 53.4% mesocarp fibre and 6.4% OPS. The higher availability of waste material from the palm oil industry has the potential to be converted into another renewable energy source (Yusoff, 2006). 140 kg of fiber and 60 kg of shell can be produced by a palm oil mill of capacity 1 tonne FFB/hr (Ngan & Ong, 1987; Mahlia et al., 2001). Table 2.2 tabulates the number of palm oil processing sectors in Malaysia.

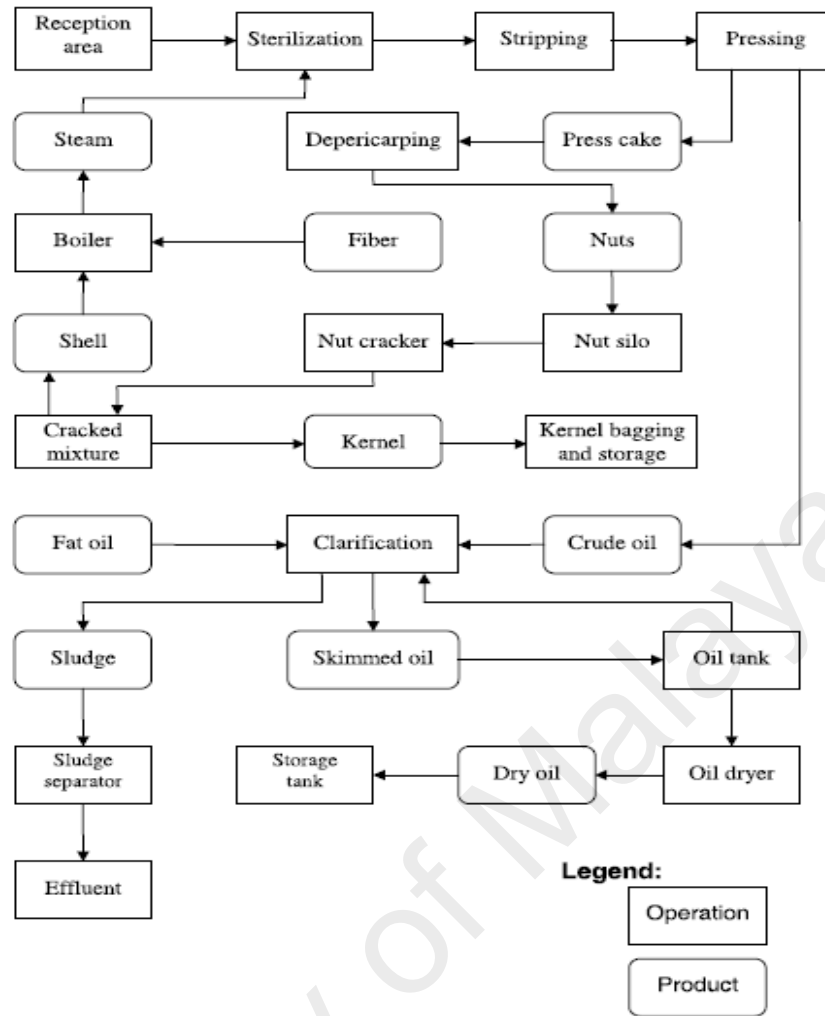

Figure 2.1: Process operation and product of palm oil mill (Mahlia et al. (2001))

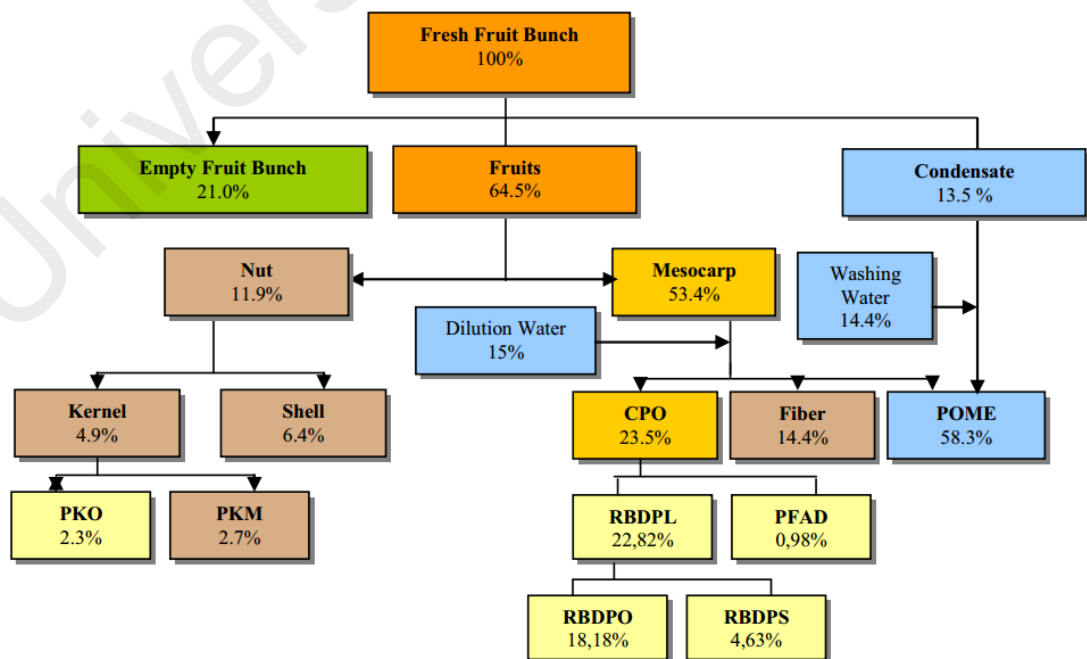

Figure 2.2: Mass balance of palm oil processing (Adapted from Hambali et al. (2010))

Table 2.2: Number of palm oil processing sectors in Malaysia (MPOB, 2015)

Sector	Peninsular Malaysia	Sabah	Sarawak	Total
FFB Mills	244	127	71	443
PK Crushers	27	12	4	43
Refineries	35	10	5	50
Oleochemicals	17	-	-	17

OPS and OPF have high dry calorific value of 20.8 GJ/ton and 18.6 GJ/ton (Ma, 1999). Yusoff (2006) mentioned that fiber and shells are pressed in the palm oil mill as a fuel to produce energy. A major drawback of the industry is the production of the waste from the processing stages which requires a proper disposal and management system. OPS, POC, OPF, palm oil fuel ash (POFA), empty fruit bunch (EFB) and palm oil mill effluent (POME) are the by-products from these stages. Around 1.5 m³ of water is expected to be required to process one tonne of FFB whereby half of this would be discharged as a wastewater (Mumtaz et al., 2010). Researchers reported that this waste contains high turbidity level and chemical oxygen demand (COD) (Latif Ahmad et al., 2003; Gobi et al., 2011). It is reported that the biochemical oxygen demand and COD values are 25000 mg/L and 50000 mg/L respectively (Mumtaz et al., 2010). Table 2.3 shows the palm oil mill distribution and plantation area for each state in Malaysia. It is obvious that most of the oil palms are cultivated in Sabah and Sarawak. The availability of large land areas could be reason behind this large cultivation in Sabah and Sarawak.

Table 2.3: Oil palm planted areas and fresh fruit bunch (FFB) yield (MPOB, 2015)

State	Oil palm planted area (hectares)	FFB Yield (tones/hectares)
Kedah	87,244	19.53
Kelantan	151,973	10.80
Terengganu	172,583	14.63
Pulau Pinang	14,447	16.26
Perak	398,314	21.24
Pahang	725,239	18.47
Negeri Sembilan	177,741	18.72
Selangor	137,336	20.63
Melaka	54,603	22.22
Johor	739,583	20.00
Sabah	1,544,223	19.99
Sarawak	1,439,359	16.21
Total	5,642,943	218.7

2.3 Hardened Properties of Palm Oil Waste Concrete

Over the years few comprehensive researches have been carried out on the utilisation of OPS, POC and POFA in concrete.

2.3.1 Palm Oil Clinker (POC)

Researchers reported that addition of POC showed only 13% to 31% reduction in strength compared to conventional concrete (Ahmad et al., 2007). The singly reinforced POC beams with reinforcement ratio lower than 0.5% showed deflection within the standard range. Besides that, the crack widths of POC beams were between 0.24 mm and 0.30 mm which is also within the regulated limits (B. S. Mohammed et al., 2014). In the latest development, researchers reported that when POC particles were incorporated with aluminium components as green roof system, the wear resistance was improved compared to the ordinary mix. It should be noted that the cavities that form

on the surface and pores surrounding the POC particles tends to lower the crack generation (Khairul Anuar et al., 2015). The conventional OPS concrete containing 25% of POC fine produced similar 28 day compressive strength compared to plain Portland cement concrete. This substitution level may be considered as an optimum as further replacement beyond 37.5% is not suitable (Shafiqh et al., 2014). Incorporation of POC in OPS concrete lowers the formation of cracks besides limiting the crack width. This may be due to the reduction in the vapour pressure as a result of the pores within the POC aggregates (Jumaat et al., 2015). Recent study on POC powder shows that the total organic carbon (TOC) for POC powder reduced through thermal activation which increases the organic content besides decreasing the porosity of the powder particles (Karim et al., 2016). Use of POC also reduces the shrinkage of the concrete in comparison to the OPS control concrete by 40% (Aslam et al., 2016). Generally most of the researches on POC focus on the use of POC as replacement to the conventional aggregates only. Besides that, the variation of the material due to the source which could play an integral part for mass concrete production is not reported till date. Sustainability and environmental components are also not highlighted by researchers.

2.3.2 Oil Palm Shell (OPS)

The studies on OPS in concrete have been extensively investigated in the past by few researchers. Mannan and Ganapathy (2002) found that use of OPS in concrete can produce strength between 20 and 25 N/mm² at 28 days which is within the limits of the structural lightweight concrete. Shafiqh et al. (2011) found from their studies that OPS can be used in concrete to produce high strength concrete between 43 MPa and 48 MPa with densities around 1870 kg/m³ and 1990 kg/m³. In addition, the water absorption property was also between 3.1% and 6.2% which are in the class of good concretes. In a separate study, Mo et al. (2014) discussed that when 1% of steel fiber is used in OPS concrete, the flexural toughness behaviour improved by 16 times. The steel-concrete

bond strength of OPS concrete was enhanced between 50% and 80% compared to conventional concrete which has similar compressive strength (Mo et al., 2015). Researchers found that addition of oil palm boiler clinker in OPS concrete between 0% and 50% managed to lower the density of the concrete by 21% to 27% (Shafiqh et al., 2014). Moreover, OPS concrete showed 3.9 and 2.2 times higher modulus of toughness compared to POC and NWC (normal weight concrete), respectively (Ahmmad et al., 2014). Use of palm oil fruit fiber at 0.5% with 10% crumb tire rubber enhanced the compressive strength compared to mix without fiber. It may due to the improvement in the bond strength through inclusion of these fibers that is connecting the composites together. Moreover, the flexural behaviour also improved with 0.5% to 1.5% of fiber addition (Abd. Aziz et al., 2014).

2.3.3 Palm Oil Fuel Ash (POFA)

Substituting cement with 80% of palm oil fuel ash (POFA) with some modifications can produce strength higher than the conventional mortar at later ages. In addition, use of ultrafine palm oil fuel ash can bring down the heat of hydration which would be suitable for application to avoid thermal cracking due to high heat (Lim et al., 2015). Incorporation of POFA and pulverized burnt clay (PBC) in SCM averted bleeding at high use of high range water reducer (HRWR) dosage whereby at mix up to 30% (15% PBC and 15% POFA) would be suitable as the no significant changes in flow diameter was observed (Hassan et al., 2014). While on the other hand, POFA which has been ground to a fine form can help to reduce the expansion and reduction in strength properties when exposed to magnesium sulfate solution (Jaturapitakkul et al., 2007). Besides that, water permeability properties of high strength concrete utilising ground POFA of higher fineness was between 3.11×10^{-14} m/s and 4.62×10^{-14} m/s which is only 50% compared to ordinary control concrete. This may due to the capability of POFA to refine the voids to elevate the density of the concrete structure (Tangchirapat

et al., 2009). Besides that, inclusion of this material also showed greater resistance when subjected to 10% magnesium sulfate solution as the expansion and compressive strength loss was minimized. It was reported by previous researchers that incorporation of fine POFA between 10% and 30% can reduce the shrinkage properties by 10-17% (Tangchirapat & Jaturapitakkul, 2010). A feasibility study which was performed on treated effluent palm oil mill to be used as mixing water in concrete showed more than 2 minutes setting time which is beyond the maximum limit (Noruzman et al., 2012). This may be contributed by the availability of oil particles which may delay the hydration process from taking place (Jones, 1990).

2.4 Self-Compacting Concrete (SCC)

SCC is one of the latest promising advancements in the construction industry to improve both hardened and fresh properties of traditionally vibrated concrete. SCC can be defined as concrete that has the ability to flow under its own weight without need of any vibration across space or reinforcements. The high powder content and enhanced viscosity properties allow for better flow ability and passing ability features. Figure 2.3 shows the differences between SCC and conventional concrete. Practically, the term rheological behaviour has been used to define or quantify the properties of SCC. From rheology point of view, SCC can be defined as concrete with low yield stress but different plastic viscosity (López et al., 2009). The advantages and ease of using SCC in construction sites have increased its popularity within the construction industry. Corinaldesi and Moriconi (2011) mentioned that fresh SCC provides good flow properties and resistance to segregation. SCC can reduce the construction period, enhance the compaction in congested sections where vibration is not possible and avoid noise pollution at construction site due to vibration (Okamura & Ouchi, 2003). On the other hand, hardened properties aspects were also improved through low voids or porosity, high strength and enhanced durability features. Researchers found that the

high amount of fine and extra fine material content in SCC enhances the interfacial zone properties (Ferrara et al., 2007). Studies also show that the bond properties of SCC are much better or almost equivalent to that of conventional vibrated concrete (Sfikas & Trezos, 2013). SCC design and evaluation properties may differ according to the engineering, judgment, material type and variety. The concrete design process has to be carried out through series of trial and error method and the properties may vary according to the possible variations listed before (Felekoğlu et al., 2007). From the aspects of working conditions, Rwamamara and Simonsson (2012) found that SCC requires much lesser physical activity which could lead to lower stress condition compared to ordinarily vibrated concrete. The minor disadvantages of SCC would be the high cost of materials, precise selection of materials, control and measurement in material properties and need for extensive trial tests (Naik et al., 2012).

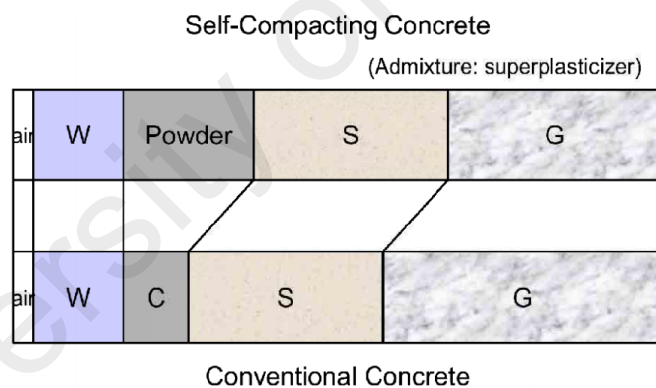

Figure 2.3: Differences between self-compacting concrete (SCC) and conventional concrete (Okamura and Ouchi (2003)) (W-water, S-sand, G-gravel, C-cement)

2.5 Mix Design for SCC

Limited mix design procedures and guidelines are available for SCC production and most of them are still not direct due to the variation in materials and changes in flow behaviours. Currently, the popular Japanese (Okamura & Ozawa, 1995) and British (P Domone, 2006) method of mix proportioning determine the suitable water powder ratio and superplasticizer (SP) dosage on paste and mortar scale. This reduces the need for

extreme amount of tests on concrete mixture. However, there is no studies to formulate or analyze the relationship between paste or mortar with SCC (Wu & An, 2014). New methods and techniques are being developed considering various aspects of the concrete. Modifications and different approach on the aggregates properties, cementitious material and rheological behaviour are being evaluated in depth to develop a new mix design methodology. Su et al. (2001) reported a mix design procedure using packing factor (PF) determination. Figure 2.4 shows the mix design steps proposed by them. PF was obtained by having a simple ratio between tightly packed state of aggregate to that of loose packed state. These values were incorporated with the unit mass of loosely piled saturated surface dry (SSD) condition aggregates to determine the aggregate content required. Additional binder materials required were introduced taking into consideration the remaining portion of SCC other than aggregate content, cement content and air content. Final adjustments were made to SP dosage as well as aggregate absorptions rate through trials to ensure sufficient SCC properties are achieved.

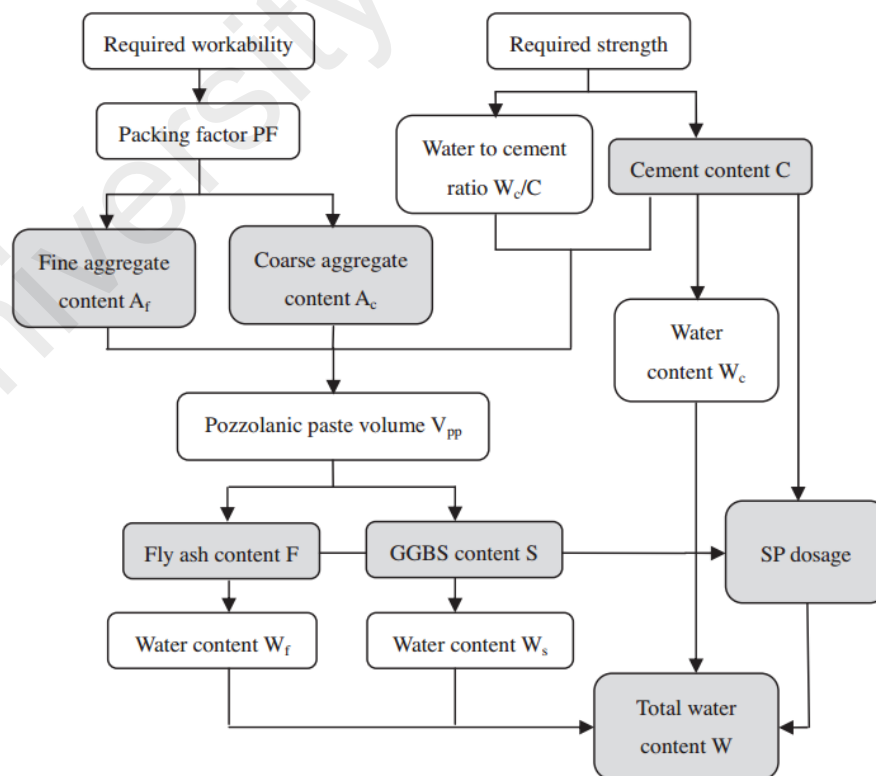

Figure 2.4: Mix design procedure for SCC using packing factor method (Su et al., 2001) (Adapted from (Shi et al., 2015))

Choi et al. (2006) conducted a different study whereby they modified Nan Su PF by evaluating the packing model for each aggregates separately and obtained the final packing values. Hwang and Hung (2005) developed a durability mix design for lightweight SCC. It was focussed on densified mixture design algorithm (DMDA) method which involves configuration between aggregate phase and paste phase. In addition, Dinakar et al. (2013) applied efficiency factor study to develop a new SCC mix design for GGBS. In their study, the slag activity efficiency was studied at different substitution levels to determine the appropriate substitution level based on needed strength. Mostofinejad and Reisi (2012) used a different method through computer simulation to predict the packing density (PD) of coarse aggregates based on their shape and grading. Discrete element method (DEM) was applied in their study for this purpose. As of their research, a friction coefficient (μ) was introduced to indicate the shape of the aggregates as the all aggregates are identified as spheres. They also reported that high PD aggregates mixtures require lower paste volume to fill in the empty spaces. This will also lead towards reduction in durability issues and help in cost cutting measures.

In a latest development, Le et al. (2015b) introduced a new method of mix design for high performance SCC using Funk and Dinger (1994) packing theory. Q value of 0.25 was used as the aggregate grading. The empty spaces within the compacted aggregates state were utilised to determine the paste volume required. SP content determined from the saturation dosage as required for mortar. The water binder (W/B) ratio was determined through the required compressive strength and the efficiency factors which are later used to check the effect of mineral admixtures on the strength of concrete. Nepomuceno et al. (2014) used a different approach on designing a SCC mix. They took into consideration mortar and coarse aggregates as two different phases. Addition of powder materials is used to control the viscosity of the mixtures. For concrete

production, binary blends with two cement and three powder additions namely limestone powder, fly ash and granite filler were incorporated. The mix design components which were given importance include volumetric of fine aggregates in overall fine aggregate volumetric content, volumetric content of coarse aggregates in overall coarse aggregate content, powder mix constituents, volume of powder to fine aggregate content, volume of water to powder, mass percentage between SP and powder content and lastly volume of mortar and coarse aggregates. The workability and strength properties were integrated to propose a new SCC mix design method.

An alternative approach through rheology of paste was adapted by Bui et al. (2002) to develop a mix design for SCC. Figure 2.5 depicts the mix design procedure proposed by them. This is an extension of the work carried out previously by Saak et al. (2001). The study involved a few important aspects such as aggregate particle size distribution, fine to coarse aggregate ratio and aggregate paste volume ratio. The empty space within the aggregates was filled with a minimum amount of paste to ensure sufficient coating on aggregates which will create the segregation resistance and flow ability. Average aggregate diameter and spacing between them is integrated to evaluate the rheological behaviour of the paste. Later on, Khaleel and Abdul Razak (2014) developed another mix design for SCC using metakaolin through three different phases. First phase involves design of cement paste and followed by mortar. Lastly, the concrete phase designed. The air content by volume of concrete was assumed at the first stage after which the cement paste proportion is determined. Sand to mortar ratio and cement paste is then altered. The right mix of mineral admixtures with cement was then decided. At the end, the amount of coarse aggregates by volume is determined for the concrete mix design.

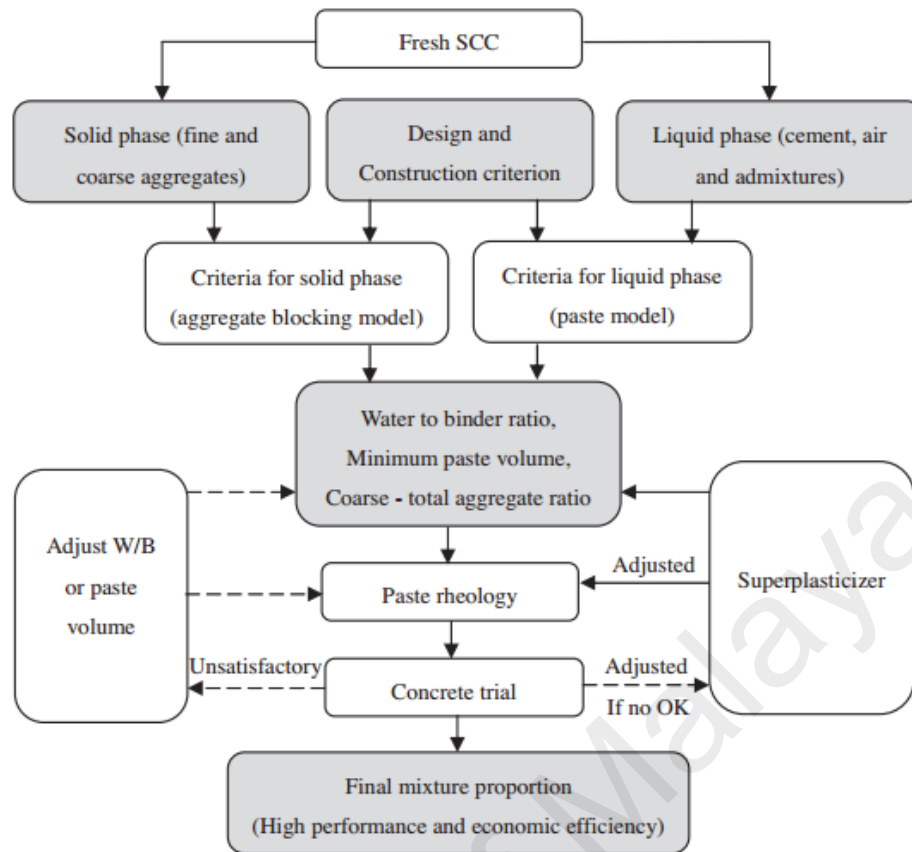

Figure 2.5: Mix design procedure based on rheology of paste (Bui et al., 2002) (Adapted from (Shi et al., 2015))

Mathew and Paul (2012) presented a work on obtaining a mix design for laterized SCC. They modified the mix design method previously produced by Su et al. (2001) which was also enhanced by Karjinni and Anadinni (2009). Trials were carried out on concrete with strength class between M20 and M40 utilising weathered laterite aggregate while also observing the filling ability and stability. The methodology indicated that the total powder content varies between 670 kg and 810 kg with fly ash content between 46% and 50%. Dinakar and Manu (2014) researched on achieving a mix design for concrete using metakaolin. They simplified the process into 5 steps. The first step involves determination of total powder content. Secondly, the percentage of metakaolin fixed based on required strength and the efficiency factors (k) obtained through the proposed equation. The third step involves setting of the water content. While the fourth step determines the coarse and fine aggregate content utilising DIN 1045 standard grading curves for combined aggregates. Finally, the fresh properties

verified through V-funnel and slump flow to assess the flow ability and L-box test to evaluate the passing ability criteria.

Sebaibi et al. (2013) proposed a different mix design method using a compressive packing model. The packing density from a polydisperse combination was checked through the help of three parameters namely PD of monosize, compaction energy and size distribution of the constituents. They also reported that, the final mix proportion contained more aggregate content than the binder to provide greater advantages in terms of economy and ecology. Ghazi and Al Jadiri (2010) used a different approach of developing a mix design through the compressive strength method which is based on ACI 211.1–91 (1991). Figure 2.6 shows the mix design method adapted by them. Based on the required strength properties, the concrete components including the aggregate content and powder content are determined concurrently. Tests are conducted on these mixes to ensure they meet the regulated required strength properties. Table 2.4 tabulates the summary of the mix design.

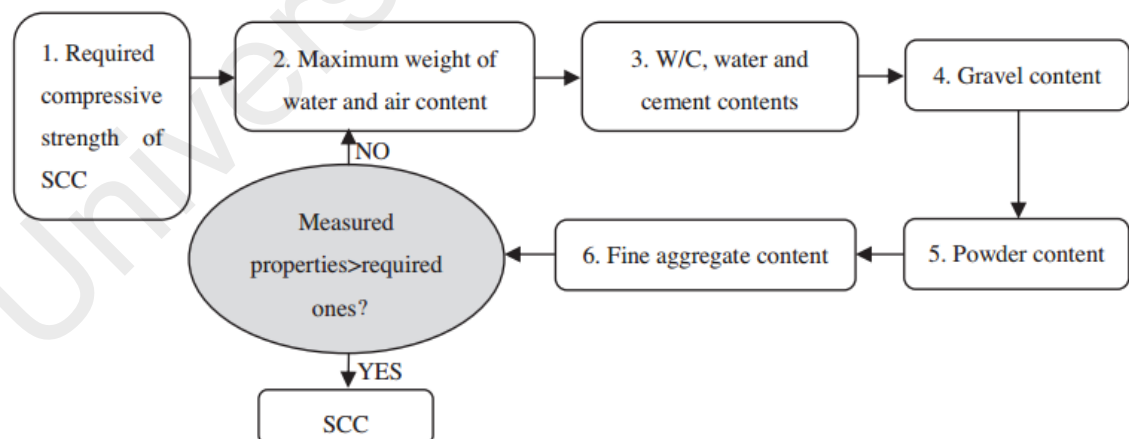

Figure 2.6: Mix design flow for SCC by compressive strength method (Ghazi & Al Jadiri, 2010) (Adapted from (Shi et al., 2015))

Table 2.4 : Summary of SCC mix design comparison

SCC Mix design	Concept of mix design
P. L. Domone (2006) & Okamura and Ozawa (1995)	Suitable water powder ratio and superplasticizer (SP) dosage on paste and mortar scale
Su et al. (2001)	Packing factor (PF) determination
Choi et al. (2006)	Modified packing factor (PF) method by evaluating the packing model for each aggregates separately
Hwang and Hung (2005)	Densified mixture design algorithm (DMDA) method which involves configuration between aggregate phase and paste phase
Dinakar et al. (2013)	Slag activity efficiency was studied at different substitution levels to determine the appropriate substitution level based on needed strength.
Mostofinejad and Reisi (2012)	Predicted the packing density (PD) of coarse aggregates based on their shape and grading using discrete element method (DEM)
Le et al. (2015b)	Aggregate packing theory
Nepomuceno et al. (2014)	Consideration of mortar and concrete as two different phases and addition of powder material to control viscosity
Bui et al. (2002)	Based on the rheological behavior of paste
Khaleel and Abdul Razak (2014)	SCC design for metakaolin using three level mix design (cement paste, mortar, concrete)
Mathew and Paul (2012)	Modified packing factor concept to observe the filling ability and stability of weathered laterite aggregate
Ghazi and Al Jadiri (2010)	Determination of aggregate content and powder concurrently based on required strength

2.6 Waste Material Consumption in SCC

Waste materials originating from processing and manufacturing stages of certain products have high economic and material value to be utilised. Currently, by-products

from agricultural industry, manufacturing industry, plastic industry, construction and quarry industry and glass industry are being widely incorporated as supplementary materials in concrete. Proper characterisation and study are required to fully understand the physical and chemical effect these materials impart to concrete when mixed together.

2.6.1 Agricultural Industry Waste

In addition to the palm oil industry, waste from rubber, paddy, sugarcane and timber manufacturing industry are also being used widely as replacement material for concrete or mortar production. Researchers reported that self-compacting rubberized concrete Young's modulus of elasticity was generally much lower but their flexural toughness was better thus resulting in improved energy absorption and ductility behaviour (Najim & Hall, 2012). On the other hand, researchers also found that SCC using rubber aggregates between 15% and 25% managed to enhance the cracking characteristics compared to conventional concrete (Turatsinze & Garros, 2008). A reduction of about 10% to 20% was observed for dynamic modulus in rubber modified self-compacting concrete (Rahman et al., 2012). When waste tire rubber powder used to produce SCC, the electrical resistivity was reported to be higher with increasing replacement level (Yung et al., 2013a). Crumb rubber addition in concrete has elevated the fracture energy capacity of the concrete by 3.5-5.4 times compared to control concrete (Grinys et al., 2013). When SCC incorporating waste rubber tire is subjected to load beyond maximum stress, the strength reduction was gradual indicating good capability of the concrete to stand against post load (Bignozzi & Sandrolini, 2006). Consumption of waste tire rubber powder passing #50 sieve at 5% increased the strength of SCC by 1-10% (Yung et al., 2013a). The fracture energy was found to have improved by 194% and 268% when 10% and 20% of sand was replaced with crumb rubber respectively (Al-Tayeb et al., 2013). Replacement of 30% saw dust ash in SCC mortar mix produced strength

higher than control mix (Elinwa et al., 2008). Addition of rice husk ash (RHA) between 10% - 15% was found to be optimum for SCC mix relying on W/B ratio whereby good self-compacting behaviour, unit weight and air content were achieved (Safiuddin et al., 2012). Replacing cement at 0% to 40% of black rice husk ash (BRHA) has the ability to produce lower autogenous shrinkage of the concrete (Chatveera & Lertwattanakul, 2011). Incorporating 30% of bagasse ash in concrete has the ability to produce compressive strength greater than control specimens (Rukzon & Chindaprasirt, 2012). Akram et al. (2009) reported that two mixes with bagasse ash produced higher compressive strength compared to control concrete which may be due to lower water/binder ratio, higher PP, pore size refinement and grain size refinement. In the latest development, use of 20% ground bagasse ash (BA20) in place of cement managed to produce greater compressive strength compared to control concrete. It should be also noted that BA 20 exhibited strength more than 55MPa at 90 days which can be classified as high strength concrete (Rerkpiboon et al., 2015). Moreover, combined waste of sugarcane bagasse ash sand and construction waste produced almost 93% of the control specimens (Moretti et al., 2016).

2.6.2 Manufacturing Industry Waste

SCC with modified fly ash showed higher crack restraining capacity than the slipform concrete (Gao et al., 2012). 35% of fly ash class C substitution with cement to develop high strength economical SCC showed enhanced compressive strength characteristics at 28 days than the ordinary concrete (Naik et al., 2012). Waste bituminous filler inclusion in SCC showed compressive strength properties similar to that of control specimen at 28 days which also satisfied the minimum value (Martín et al., 2013). Strength of SCC increased when ground clay brick powder consumed up to 250 kg/m³, while usage of 12.5% and 37.5% of GCB replacing ordinary Portland cement (OPC) paste produced higher strength achievement at 28-1095 days (Heikal et

al., 2013). Utilisation of treated effluent originating from heavy industry has the capability to act as a substitute for mixing water whereby it can produce greater compressive strength compared to potable water (Noruzman et al., 2012). Hamad et al. (2003) reported that incorporation of used engine oil as air entraining agent in concrete reduced the concrete properties such as flexural strength, modulus of elasticity and splitting tensile strength by 21%, 6% and 17% respectively. Compressive strength and UPV values were greater by 5% to 15% when brass by-products were substituted with cement (Zubaidi et al., 2013). Colliery spoil when used with sand and aggregates has the ability to produce concrete with almost 42% of the conventional concrete strength (Kinuthia et al., 2009). Although GGBS incorporation reduced the early strength achievement but at 56 days and 90 days the strength was similar to that of control concrete (Boukendakdji et al., 2012). Biomass fly ash which was replaced as conventional filler produced better hardened properties results than conventional concrete and commercial filler concrete in terms of compressive strength (Cuenca et al., 2013). Use of recovered fillers from bituminous mixture plants in concrete gave similar strength, carbonation durability and self-compactability nature compared to conventional concrete of same water cement ratio and dosage (Martín et al., 2013). Red mud obtained from the alumina refineries when utilised in SCC showed lower hardened density when replacement level increased. However, at 90 days of curing the compressive strength and tensile strength were enhanced when the substitution level between 30% and 40% to that of fly ash (Liu & Poon). When silica fume was utilised at 15%, a higher strength of 10% for 450 kg/m³ and 12% for 550 kg/m³ can be obtained in place of 30% fly ash substitution (Mohamed, 2011). Steel chips which are used in place of sand produced higher compressive strength concrete when the replacement amount increased (Alwaeli & Nadziakiewicz, 2012). Incorporation of natural pozzolan with waste materials such as limestone powder (LSP), cement kiln dust and pulverised steel

slag can produce high strength SCC of 36-49 MPa, 47-56 MPa, 65-68 MPa and 70-83 MPa at 3, 7, 28 and 90 days respectively (Tennich et al., 2015). Spent catalysts from two different refineries used to replace sand showed low level of leachate content and expected not to have any dangerous effect to the environment. Use of 10% Sohar spent catalyst produced strength properties greater than control specimens (Al-Jabri et al., 2013).

2.6.3 Plastic Industry Waste

Addition of waste polyethylene terephthalate (PET) bottles lightweight aggregates in concrete showed similar structural efficiency behaviour to that of ordinary concrete (Choi et al., 2009). Furthermore, Yang et al. (2015) found that addition of recycled modified polypropylene (PP) plastic particles enhances the compressive strength, flexural strength and splitting tensile strength until 15% replacement level. Further incorporation reduced the strength which could be due to additional water discharge to cause weakening of the cement paste plastic zone. Incorporation of PET bottles in lightweight concrete showed only 21% decrement in strength for 75% replacement level for same water cement ratio. The lower weight of PET and composite strength may be the reason behind this scenario (Choi et al., 2005). Waste plastic utilisation in concrete showed lower concrete strength behaviour which may be primarily due to reduced adhesive properties between cement paste and plastic (Ismail & Al-Hashmi, 2008). Ethylene vinyl acetate (EVA) waste used in concrete can help to increase the toughness and compressive over tensile strength characteristics (Lima et al., 2010). Ghernouti et al. (2015) explained that the splitting tensile properties of concrete incorporating plastic bag waste fibers (PBWF) enhanced by almost 74% depending on the quantity used irrespective of the fiber length. They also reported that PBWF can prevent sudden failure and elevate the crack toughness.

2.6.4 Glass Industry Waste

Flexural strength of the self-compacting glass concrete improved higher than ordinary concrete when replaced with 20% and 30% of glass sand (H.-Y. Wang & W.-L. Huang, 2010). Sewage sludge and glass powder use in lightweight concrete produced greater electrical resistivity values than conventional concrete (Tuan et al., 2013). Incorporation of liquid crystal glass sand as substitution to aggregates between 10% - 30% performed better in terms of ultrasonic pulse velocity test (UPV) and electrical resistivity with the highest at 30% (H.-Y. Wang & W.-L. Huang, 2010). Utilisation of liquid crystal device (LCD) glass sand at 30% replacement level has the ability to elevate the UPV and electrical resistivity values with respect to control mixes (H.-Y. Wang & W.-L. Huang, 2010). Addition of crushed funnel glass and treated funnel glass in heavyweight barite concrete showed lower drying shrinkage properties compared to conventional concrete (Ling & Poon, 2012). This may be due to the lower water absorption properties of these additions. This finding was almost similar to the one reported by (S. Kou & C. Poon, 2009); S. C. Kou and C. S. Poon (2009) which also mentioned that lower drying shrinkage was observed when 45% of recycled glass was used in concrete as replacement for fine aggregates. Utilisation of fine glass fiber reinforced polymer waste in place of sand exhibited slight reduction of splitting tensile strength and modulus of elasticity by 2.7% and 3.0% respectively (Correia et al., 2011). When 20% to 30% of glass sand used in self-compacting glass sand concrete, the flexural strength was higher than control specimens at 90 days (H. Y. Wang & W. L. Huang, 2010).

2.6.5 Construction and Quarry Industry Waste

Topçu et al. (2009) found that addition of 200kg/m³ marble dust which is the maximum and an optimum amount has positive effects on the fresh and hardened behaviour of SCC. Use of waste tiles gravel and waste marbles as fillers increased the

tensile strength properties by 4% and 42% respectively (Tennich et al., 2015). Based on paste and concrete experiments, it was found that SCC utilising quarry dust could be used for production, but consideration has to be given to increasing SP ratio due to shape and size of quarry dust particles (Gołaszewski & Szwabowski, 2004). Besides that, SCC with fine recycled aggregates was found to have increased resistance to chloride ion penetration which may due to high ratio of finer particles (<0.3mm) compared to river sand (S. C. Kou & C. S. Poon, 2009). Granite in concrete which is replaced with less than 30% of fresh concrete waste as coarse aggregates was able to produce concrete with a strength of 40 MPa at 28 days after casting. Although the dry shrinkage and chloride penetration increased with fresh concrete waste replacement level, at 90 days these values were within the stipulated range provided that the water cement ratio was kept at 0.30 and the substitution level less than 30% (Kou et al., 2012). Although recycled masonry aggregates addition to replace conventional sand showed linear decrement in strength, all the mortar samples with 50% substitution showed strength values above 10 MPa at 28 days (Ledesma et al., 2015). Pumice, tuff and diatomite incorporated in self-compacting lightweight concrete (SCLC) showed greater abrasion depth than conventional concrete regardless of their water to binder ratio (Topçu & Uygunoğlu, 2010). Increasing dolomite powder which is generally a non-pozzolanic material by substitution with fly ash shows decrease in compressive strength but generally satisfied for use in structures (Barbhuiya, 2011). SCC mix with 75% fly ash and 25% dolomite powder showed good SCC properties and the compressive strength achievement is suitable for construction applications (Barbhuiya, 2011). A past study showed that utilisation of waste foundry sand in place of normal sand in ready mix concrete produced satisfactory mechanical, environmental and micro-structural impacts provided that the replacement level do not exceed 20% (Basar & Deveci Aksoy, 2012). Moreover, equal quantities of bottom ash and waste foundry sand used to

substitute sand showed improvement in strength of about 14.52%-23.89% and 2.02%-6.94% at 28-90 days and 90-365 days respectively (Aggarwal & Siddique, 2014). Despite reducing the compressive strength and splitting tensile of concrete, addition of foundry sand at 10% replacement showed comparable results to that of conventional concrete (Guney et al., 2010). Incorporation of 25% of recycled ceramic aggregates has the ability to improve the compressive strength and spitting tensile strength to that of control specimens by 12% to 25% (Medina et al., 2012).

2.6.6 Outcome of Waste Material Utilisation in SCC

These studies prove that waste materials have been widely used to replace conventional aggregates and powder materials. Generally, most of them gave a positive outcome in terms of hardened and durability properties which promotes sustainability largely. In addition to the combined effect of conventional aggregates and cementitious material, utilisation of lightweight aggregate only in concrete also warrants a review.

2.7 Lightweight Aggregates in Conventional Concrete and SCC

Natural and manufactured lightweight aggregates are widely used in conventional concrete and SCC. Wu et al. (2009) investigated the fresh properties of lightweight SCC using expanded shale and sand showed satisfactory SCC properties besides producing high strength lightweight concrete. Sewage sludge glass powder inclusion resulted in an improved hardened property whereby almost 73% of strength can be attained besides producing good electrical surface resistivity values (Tuan et al., 2013). Researchers found that municipal solid waste incinerator fly ash and reservoir sediment can be utilised to develop lightweight aggregates to produce lightweight SCC with fine strength and satisfactory UPV and electrical resistivity values (Hwang et al., 2012). Addition of lightweight slag aggregates produced concrete compressive strength of about 55 MPa and also showed enhanced shear capacity behaviour whereby the beam

did not show any significant crack. This could be due to the enhanced aggregate interconnection (Abouhussien et al., 2015). Alduaij et al. (1999) also found from their research that the high water absorbing properties of lightweight bricks, light expanded clay aggregate (LECA) and no fines aggregates gives significant effect to water demand which subsequently lead to greater water cement ratio. Bogas et al. (2012) reported that the enhanced self-compacting capability and slight reduction in aggregates content of the lightweight aggregates mixtures managed to produce higher elasticity behaviour as compared to the conventional vibrated lightweight concrete. They also reported that SCLC with Arlita managed to produce 15% higher structural efficiency value compared to self-compacting normal weight aggregate concrete.

Volland and Brötz (2015) found that addition of 20% of zeolite in sand sludge as the main component managed to lower the temperature of the process developing lightweight aggregates by 50°C besides creating almost 60-70% porous structure aggregate. Use of furnace bottom ash (FBA) as a replacement material for fine aggregates reduced the thermal conductivity of the samples due to higher void content of FBA. This indicates the applicability of the material to be utilised as an envelope in building to save energy (Zhang & Poon, 2015). Volcanic pumice can be used as coarse aggregates in the production of lightweight concretes whereby it possesses greater shock absorbing properties compared to conventional concrete without taking into consideration the impact velocity and buffer layer thickness (Onoue et al., 2015). An ultra-lightweight concrete with density of about 650-700 kg/m³ can produce thermal conductivity of 0.12 W/(mK) and strength of 10 N/mm². In addition, this concrete produced also reduced the water penetration properties and the lightweight aggregates utilised do not have alkali-silica reaction (Yu et al., 2015).

Researchers found that addition of rigid polyurethane (PUR) foam waste for coarse aggregates managed to produce lightweight concrete with strength between 8 MPa and 16 MPa and modulus of elasticity between 10 GPa and 15 GPa (Ben Fraj et al., 2010). Use of lightweight aggregates made up of sewage sludge for nonstructural concrete managed to produce lightweight concrete with density between 1400 kg/m³ and 1500 kg/m³ and thermal conductivity between 0.59 W/mK and 0.73 W/mK. In addition, this aggregate also did not exhibit any toxic components when both minimum or maximum sewage sludge was utilised (Mun, 2007). When waste LCD glass and waste rubber tire particles are combined for lightweight concrete production, the surface resistivity of 70% replacement level showed 1.8 times higher values compared to control concrete. This was probably because of the insulating characteristics of these waste materials (Chen et al., 2013). Karahan et al. (2012) reported that the greater fineness of metakaolin enhanced the water absorption capacity and porosity characteristics of SCLC. Polypropylene fiber introduction in SCC incorporating LECA elevated both splitting tensile strength and flexural strength (Mazaheripour et al., 2011). Researchers reported that a regression coefficient of about 0.92 was achieved for compressive strength and splitting tensile strength for high strength lightweight self-compacting concrete (Choi et al., 2006). According to Bogas et al. (2015), substitution of lightweight aggregate with recycled lightweight concrete aggregates generally enhanced the structural efficiency values of the concrete. From the overall analysis, it should be noted that few studies have been carried out to incorporate lightweight waste material from agricultural industry especially palm oil industry in concrete or mortar.

2.8 Durability Properties of Conventional Concrete and SCC

The durability properties of conventional concrete and SCC have to be assessed thoroughly to evaluate the long term behaviour of a concrete. Andrade (2004) and Maia et al. (2012) mentioned that electrical resistivity helps to provide some insight on the

void network or connectivity which helps in diagnose of gas or liquid intrusion in concrete. Vijayalakshmi et al. (2013) reported that the presence of void in the dense structure of concrete is closely related to the electrical resistivity of the concrete. In their study, granite powder (GP) provides greater surface area resulting in lower workability of the concrete to cause lower packing level and subsequently creating greater void structure (Vijayalakshmi et al., 2013). Addition of imploded glass and crushed glass at 10% and 20% replacement level managed to enhance the chloride ion ingress resistance in concrete (Cassar & Camilleri, 2012). Elevation in fine recycled concrete aggregate content has increased the resistance of concrete against chloride ion penetration (S. C. Kou & C. S. Poon, 2009). Incorporation of recycled glass in SCC above 600°C shows good resistance to water ingress due to the filling ability of molten glass within the concrete pores (Ling et al., 2012). Glass aggregates utilisation in concrete showed similar carbonation depth to that of control concrete at 91 days (de Castro & de Brito, 2013). Incorporation of metakaolin enhanced the pore structure system to create a lower connection between pores to bring down rapid chloride penetration test (RCPT) values. This is probably caused by the reduction in OH⁻ ions as a result of pozzolanic reaction within the pore solution as reported by another research (Ramezaniapour, 2014; Ramezaniapour et al., 2014).

The higher content of alumina in metakaolin has resulted in greater weight reduction and degradation of SCC which was soaked in sulfuric acid. This situation leads to production of calcium sulfoaluminate (ettringite) (Kannan & Ganesan, 2014). Preceding research shows that the reaction between alumina (Al₂O₃) and sulfate (SO₄) and the ratio between them influences the production of ettringite (Merlini et al., 2008). The already set cement paste is disturbed due to the presence of ettringite causes expansion in concrete (Rawal, 2003). Utilising GP also elevates the production of ettringite to cause decay in concrete due to significant presence of sulphur ions which helps to

enhance the sulfate strength (Vijayalakshmi et al., 2013). A. Hassan et al. (2013) found that addition of different types of mineral in the form of fly ash, RHA and GGBS produced higher strength under magnesium sulfate attack compared to normal water soaked specimens. Milled glass addition in concrete produces lower water absorption characteristics as the empty voids or pores in concrete matrix is generally filled leading towards highly packed concrete matrix (Nassar & Soroushian, 2012). The porosity ratio presence within the interfacial transition zone (ITZ) greatly contributes towards significant difference in permeation characteristics between ceramic insulator waste and conventional aggregates concrete (Senthamarai et al., 2011). The rougher properties of normal aggregates compared to ceramic insulator waste which are smoother may affect the creation of good bond. Inclusion of 20% waste glass powder enhanced the mortar chloride diffusion properties in comparison to conventional mixes and mixes with silica fume (Matos & Sousa-Coutinho, 2012).

Researchers found that inclusion of fly ash lightweight aggregates produced 'low' to 'very low' chloride penetration rate than the natural aggregates, indicating the suitability of the material to resist against reinforcement corrosion (Kayali, 2008). Addition of metakaolin performed better in terms of surface resistivity compared to Pomis, Trass and limestone by 15.3%, 63.6% and 68.2% respectively. This may be attributed to the C-S-H gel introduction which produces lesser voids due to enhancement in pore structure. Although these mineral additives have the capability to take up C_3A , this property is still less effective (Ramezani pour et al., 2014). Addition of POFA up to 20% in SCC improved the reduction in strength due to sulfate attack which may be caused by the pozzolanic activity of POFA. Decrement in free calcium $Ca(OH)_2$ content from cement hydration process as a result of C-S-H formation refined the pores to make the concrete much denser (Ranjbar et al., 2015). The use of kaolin waste in concrete produced 'very low' chloride penetration rate (<1000 Coulombs) although the water

absorption and porosity values were higher. This can be explained through the characteristic of kaolin itself which has greater porous nature thus providing greater capillary porosity (Lotfy et al., 2015).

2.9 Rheological Properties of Self-Compacting Mortar and SCC

In a general situation, the rheology of a concrete mix is affected by coarse aggregate content, paste volume, additives and water/powder ratio used (PL Domone, 2006). Based on rheological studies, to achieve 20 Pa of yield stress of cement paste, the SP dosage required for paste with granite fillers was 0.35% compared to 0.15% for limestone powder which also implies increase in cost (Gołaszewski & Szwabowski, 2004). The plastic viscosity of the SCC mix reduced with the increase in the addition of slag (Boukendakdji et al., 2012). Saleh et al. (2015) found from their study that incorporation of metakaolin, Class F fly ash, Class C fly ash and viscosity modifying admixtures (VMA) tends to increase the plastic viscosity of the concrete mix than the reference mixtures irrespective of their water to binder ratio. In their study, highest plastic viscosity was observed with 36% metakaolin inclusion. The trend changed opposite way when silica fume and blast furnace slag was utilised in place of cement Gesoglu et al. (2015). Research proved that addition of zeolite has the capability to alter the rheological properties of concrete whereby at constant SP ratio the yield stress and viscosity increases (Şahmaran et al., 2008). Besides that, replacement of blast furnace slag with cement lowers the viscosity and yield stress of cement paste (Park et al., 2005). However, this could be on the opposite trend whereby surface area of cement and slag plays a vital role to impart different water requirements. This was observed by a few researchers in their study (Atzeni et al., 1986; Adjoudj et al., 2014).

Use of LSP with higher fineness in self-compacting cement paste tends to reduce the viscosity indicating lowering in yield stress of the mixture (Adjoudj et al., 2014). Silica

fume or natural pozzolan incorporation can lead to 3 to 10 times increment in yield stress as result of improved interaction between fine particles (Nanthagopalan et al., 2008; Şahmaran et al., 2008; Hallal et al., 2010). From another point of view, the lower density of natural pozzolans produces greater paste volume which in turn increases the viscosity or plasticity of the paste (Şahmaran et al., 2008). Moreover, Le et al. (2015a) found that higher mean particle size (higher pore volume and water demand) of RHA increased the viscosity and yield stress of the mortar which were concurrent with mini slump flow and T_{250} time results. Use of sugar cane baggase ash as a replacement for cement produced greater yield stress and viscosity values which are highly due to the morphology of the particles. The tendency of the particles to form agglomerates is high whereby addition of water increases the packing density resulting in reduction in availability of free water content (Jiménez-Quero et al., 2013). Surface area of mineral admixtures plays a vital role to affect the yield stress and viscosity of the mixes. Detailed microstructure studies showed that POFA and PBC have Brunauer, Emmett and Teller (BET) specific surface area of 23.75 m²/kg and 2.98 m²/kg respectively (I. Hassan et al., 2013). The highly irregular and porous nature together with greater surface area of POFA increases the viscosity and yield stress of the mixture (Hassan et al., 2014). Utilisation of fine recycled aggregates in SCC increases the viscosity of the mix which is evident from the increasing slope of torque-velocity curve. This change is due to the high water absorption properties of this aggregate (Carro-López et al., 2015). Increasing slag content from 30% to 90% produced a plastic viscosity range between 162.5 Pa.s and 418.2 Pa.s (Sethy et al., 2016). Higher replacement level produced lower yield stress and viscosity may be contributed by the ability of slag to disperse the agglomeration of cement particles (Nehdi et al., 2004). It should be noted that few studies are carried out on assessing the rheological behaviour of concrete or mortar on agricultural waste especially from the palm oil industry.

2.10 Sustainability and Environmental Assessment

Cement production or processing stages are known to be a major carbon emitting industry whereby for every ton of cement, about 900 kg of CO₂ is discharged (Hasanbeigi et al., 2010; Benhelal et al., 2013). This value is about 5-7% of the anthropogenic CO₂ discharge worldwide (Chen et al., 2010; Benhelal et al., 2013). Malhotra (1999) reported precisely that the cement industry itself contributes around 7% of overall CO₂ generated. Table 2.4 tabulates the total global carbon emission from cement production. Researchers found that when GGBS is incorporated in cement as a replacement for cement, there is a 47.5% decrease in greenhouse gas emission if the supply is not constrained (Crossin, 2015). Slag addition in concrete managed to lower down the carbon dioxide emission by 29.2% to 46.1% and gave between 21.1% and 36.5% of energy savings (Prusinski et al., 2004). The cost of cement was reported to have decreased by 31.5% with 25% replacement of RHA (Khan et al., 2012). Compared to control specimens, the concrete with 5% of RHA produced lower cost per m³ for compressive strength between 35 MPa and 55 MPa with no regards to curing time intervals (Gastaldini et al., 2014). Sua-iam and Makul (2014) found from their study that incorporation of unprocessed lignite coal fly ash and RHA in place of cement and fine aggregates respectively, helped to decrease the cost of SCC production. Baggase ash inclusion in concrete can lower down the cost of SCC by 35.63% when compared to conventional concrete (Akram et al., 2009). Study performed on SCC using alumina waste showed substantial cost saving whereby at 75% replacement level with 550 kg/m³ powder content, the cost of concrete was saved by 1.0 US dollar/MPa/m³ (Sua-iam & Makul, 2015).

Table 2.5: Global carbon emissions from cement production (Ali et al., 2011)

Country	Cement production (Tg)	Clinker/cement ratio (%)	Primary intensity (MJ/kg)	Primary energy (PJ)	Process carbon (Tg CO ₂)	Carbon emissions (Tg CO ₂)	Total (Tg CO ₂)
China	423	83	5	2117	175	197	372
Europe	182		4.1	749	73	56	129
OECD Pacific	151		3.5	533	65	41	105
Other ASIA	124		4.9	613	56	179	105
Middle East	111		5.1	563	51	44	95
North America	88		5.4	480	39	40	78
EE/FSU	101		5.5	558	42	38	80
Latin America	97		4.7	462	42	30	71
India	62	89	5	309	28	30	60
Africa	41		4.9	201	18	15	33
Total	1381		4.8	6585	587	830	1126

Meyer (2009) has outlined five methods or strategies to overcome the environmental effects in construction industry: (1) substitute as much as possible Portland cement using waste from the industrial processing stages (2) utilisation of recycled materials as a replacement for natural materials (3) enhancing the durability and service life of building which will lower the materials required for substitution (4) enhance mechanical and other properties of concrete to reduce material consumption (5) recycled wash water. Three mineral admixtures (fly ash, GGBS, LSP) incorporated for SCC production managed to reduce the environmental impact as it managed to reduce the e-CO₂ index, e-resource index and e-energy index (Long et al., 2015). Substitution of 65% slag in place of 100% cement managed to reduce the emission for concrete grade 32MPa and 40MPa by 42.7% and 44.8% respectively (Berndt, 2015). Naik et al. (2012) reported that almost 39.6% of cost can be saved when cement is replaced with 55% fly ash. Replacement of 20% Class C fly ash with foundry silica-dust produced similar cost of materials compared to conventional concrete (Kraus et al., 2009). Use of 40% waste marble as a replacement material for production of concrete paving blocks reduces cost by 12% (Gencel et al., 2012). Addition of 15% sewage sludge ash which produced similar technical performance compared to control specimen showed 7.7% of savings per ton of concrete (Baeza-Brotons et al., 2014). Generally, cost, sustainability and environmental assessment of concrete incorporating agricultural waste are not highlighted in the past by researchers.

2.11 Utilisation of Waste Material for Non-Structural Applications

Few non-structural applications incorporating waste material have been designed and tested to highlight the potential of these materials as an alternative. Use of 35% marble powder in production of fired bricks showed the lowest thermal conductivity in the range between 0.401 and 0.411 W/mK (Sutcu et al., 2015). When 4 wt.% of sunflower seed cake of lowest grinding was utilised to produce fired clay bricks, the bending strength and thermal conductivity were reduced by 17% and 61% respectively (Bories et al., 2015). Ceramic bricks with 10 wt.% compost, 5 wt.% sawdust, 15 wt.% spent earth from oil filtration and marble waste satisfied the mechanical and normal standards of control clay bricks (Eliche-Quesada et al., 2012). Blending 7% OPC, 0.7% cement bypass dust and 6.3% GGBS for production of concrete paving block managed to satisfy 3.6MPa spitting tensile strength requirement besides lowering the cement content up to 30% (Ganjian et al., 2015). Porcelain tile waste utilised up to 20% to substitute cement in paving blocks achieved 50 MPa of strength required for heavy vehicles. In addition, replacement of sand with porcelain waste decreased the water absorption and porosity of the paving blocks (Penteado et al., 2016).

Furthermore, cathode ray tube funnel glass incorporated in concrete paving blocks enhanced the water absorption and drying shrinkage besides producing satisfactory compressive strength ($>45\text{MPa}$) and alkali silica reaction (ASR) expansion ($<0.1\%$) (Ling & Poon, 2014). Replacement of waste clay brick from earthquake waste as fine (50% to 75%) and coarse aggregates (25%) was suitable to produce non-structural partition wall blocks (Xiao et al., 2011). Pre-fabricated concrete interlocking blocks with crushed sand stone and marble waste achieved the minimum splitting tensile strength (3.6 MPa) as stipulated in standard but not with 40% fly ash addition (Uygunoğlu et al., 2012). Recycled crushed glass and recycled fine aggregates can be used at 50:50 ratio with 10% pulverised fly ash (PFA) to produce environmentally

feasible concrete paving blocks (Lam et al., 2007). Strength of tactile paving blocks using tire rubber decreased with increasing replacement level expect for 10% substitution whereby the strength was higher by 8.5% and 2.2% at 7 and 28 days respectively (da Silva et al., 2015). Incorporation of 50% fine and 75% coarse crushed brick and tile aggregates produced satisfactory geometrical, mechanical, acoustic and thermal properties as stipulated by the national standard for concrete block floor and in beam systems (Miličević et al., 2015). Concrete blocks with 25% of waste glass powder showed only 16% lower strength properties compared to control blocks after a period of one year (Chidiac & Mihaljevic, 2011). Table 2.6 compares the wastes in concrete.

Table 2.6 : Comparison of wastes in concrete

Reference	Type of waste	Content	Findings
Jumaat et al. (2015)	Agricultural waste	Palm oil clinker	Lowers formation of crack
Shafigh et al. (2011)	Agricultural waste	Oil palm shell	High strength concrete (43-48MPa)
(Mo et al., 2015)	Agricultural waste	Oil palm shell	50-80% enhancement in bond strength
Tangchirapat and Jaturapitakkul (2010)	Agricultural waste	Palm oil fuel ash	10-17% shrinkage reduction
Kinuthia et al. (2009)	Manufacturing industry waste	Colliery spoil	42% of conventional concrete strength
Martín et al. (2013)	Manufacturing industry waste	Fillers from bituminous plant	Similar strength, carbonation durability to control
Ghernouti et al. (2015)	Manufacturing industry waste	Plastic bag waste fibers	Splitting tensile enhanced by 75%
Ling and Poon (2012)	Glass industry waste	Crushed funnel glass	Reduced drying shrinkage
Tennich et al. (2015)	Construction and quarry industry waste	Waste tiles gravel and waste marble	Increased tensile strength by 4% and 42%, respectively

2.12 Knowledge Gap in Palm Oil Waste Utilisation for the Construction Industry

From the thorough literature analysis carried out, it is evident that very few research works have emphasized on the use of POC in concrete (Ahmad et al., 2007; Mohammed et al., 2013; Shafiqh et al., 2014; Jumaat et al., 2015). The performance of POC was not entirely explored as the use was very much limited as aggregates only until today. The quality of the POC itself as a waste material was not characterised completely from the physical and chemical point of view. Furthermore, the variation in terms of waste source also plays a crucial role if it is intended to be incorporated into construction industry. It has to be noted that palm oil mill is available throughout Malaysia. However, no data is available on the variation in terms of physical and chemical properties of POC from various parts of Malaysia till date. It is crucial to study the feasibility of POC itself especially taking into account the availability of the material from various sources in Malaysia.

Besides that, utilisation of waste materials especially agricultural waste was limited in SCC. This may be due to the special characteristics of the waste material itself which are not addressed for use in SCC. The potential of palm oil mill waste in different forms such as fine aggregates and powder material were also not tackled in the past. The environmental and sustainability components which are becoming an integral part of the construction industry are another branch of research which is not highlighted before. Lastly, very few researchers have stressed on the development of a useful or pertinent final consumer product incorporating waste material. Taking all of these into account, this study was designed to address and highlight every aspect of POC utilization. Without these considerations, application of POC in construction industry would be ill-advised.

CHAPTER 3: METHODOLOGY

3.1 Material Characterisation Tests

POC is one of the by-products originating from the palm oil processing. Hence, an extensive material characterisation study is required to ensure all the physical and chemical properties are evaluated and tested. These tests are also vital as they contribute towards the development of the new mix design for SCC which is related to POC properties. In addition to POC utilisation as aggregates, it is also being employed to supplement the need for extra paste volume based on PP method. Both physical and chemical characterisation tests were performed on POC coarse, POC fine and POC powder. Physical tests involve specific gravity, water absorption, moisture content, aggregate crushing value (ACV) and aggregate impact value (AIV). Chemical tests carried out were X-ray fluorescence (XRF) and X-ray diffraction (XRD). For the major works carried out, POC samples for the tests were collected from Seri Ulu Langat palm oil mill located at Dengkil, Selangor. Meanwhile, POC samples were also collected throughout Malaysia for feasibility studies.

3.1.1 Moisture Content of Aggregates

Moisture content of aggregates was determined based on BS 812-109 (1990). This is an important test which gives the amount of moisture available within the aggregates. For this test, 500g of fine aggregates and 2500g of coarse aggregates were prepared before measuring the dry weight. They were then placed in an oven for 24 hours at temperature of about 105°C. The weight loss of samples after being placed in the oven gives the moisture content. Furthermore, this test is useful for mix design purpose considering the aggregates condition during casting.

$$\text{Moisture content (\%)} = \frac{M_1 - M_2}{M_2} \times 100 \quad (1)$$

where M_1 = mass of the air-dried aggregates (g)

M_2 = mass of the oven dry aggregates (g)

3.1.2 Specific Gravity and Water Absorption for Aggregates

The specific gravity of aggregates and binders were determined to ensure the correct amounts are utilised during mix proportioning. This test was performed according to BS 812-2:1995 (1995). The aggregates prepared for this study were immersed in water with minimum 50mm of water on top of the basket. To remove any entrapped air, the basket was taken out from the water and immersed, and the process repeated for 25 times. The aggregates were then allowed to be immersed completely in water for about $24 \text{ hr} \pm 0.5 \text{ hr}$. Weight of the basket with aggregates in water was taken (B). The aggregates were then placed on a dry absorbent cloth. The empty basket was later measured for its mass in water (C). Using a cloth, the aggregates were made surface dry. Once the water on the aggregate surface is not visible, the weight of the aggregates was taken (A). For water absorption determination, the aggregates were then placed in an oven at $105^\circ\text{C} \pm 5^\circ\text{C}$ for $24 \text{ hr} \pm 0.5 \text{ hr}$. All the values were calculated based on the formula below.

$$\text{Apparent specific gravity} = \frac{D}{D - (B - C)} \quad (2)$$

$$\text{Specific gravity (Saturated Surface Dry (SSD))} = \frac{A}{A - (B - C)} \quad (3)$$

$$\text{Oven specific gravity (OD)} = \frac{D}{A - (B - C)} \quad (4)$$

$$\text{Absorption (\%)} = \frac{A - D}{D} \times 100\% \quad (5)$$

where A = mass of saturated surface-dry (SSD) sample in air (g)

B = apparent mass in water of the basket containing the sample of saturated aggregate (g)

C = apparent mass in water of the empty basket (g)

D = mass of the oven-dried aggregate in air (g)

3.1.3 Aggregate Crushing Value (ACV)

This test was carried out according to BS 812-110 (1990). Crushing value of aggregates is an important parameter to determine the strength of the aggregate only. The principle of this method is to determine the aggregates resistance against gradually increasing crushing load. The aggregates to be tested were placed within steel compartment which is fitted with a moving steel plunger. The aggregates were then subjected to load at a standard loading rate. The rate of crushing is dependent on the type and characteristics of the aggregate. Aggregates in between 10 to 14mm were prepared (segregated by using a sieve) for this study. Three test specimens were prepared to obtain an average value. The specimens were then oven dried at a temperature of $105 \pm 5^\circ\text{C}$ for not more than 4 hours. They were then cooled down to room temperature before testing. The aggregates were then placed in a steel cylinder in three layers whereby each layer was subjected to 25 equal strokes from a height of about 50mm using a tamping rod. The top surface of the aggregates was then leveled before the plunger was placed to rest on them. The setup was then placed within the plates of a testing machine with setting to reach 400 kN in $10 \text{ min} \pm 30 \text{ s}$. Once the test is over, the crushed portion of the aggregates were then removed slowly from the cylinder to a tray. The samples were then sieved (mesh size 2.36mm) until no aggregates were observed to pass through for a minute. The aggregate crushing values were then determined using the formula below.

$$\text{ACV} = \frac{m_2}{m_1} \times 100\% \quad (6)$$

where m_1 = mass of the test sample before crushing (g)

m_2 = mass of the test sample passing through 2.36mm sieve after crushing (g)

This method is not applicable or suitable if the ACV is more than 30. In such cases, the test method has to be modified according to BS 812-111 (1990) which is referred as Ten Per Cent Fines value (TFV) test. In this test, the loading rate was set to produce a given plunger penetration within $10\text{min} \pm 30\text{s}$ according to the type and characteristics of the aggregate; 15mm for round or partially rounded aggregates, 20mm for normally crushed aggregates, 24mm for vesicular (honeycombed) aggregates. The values of TFV obtained were then checked to be within a range of 7.5% to 12.5%. The required force to produce TFV is determined from the test setup.

$$\text{TFV} = \frac{14f}{m + 4} \quad (7)$$

where f = maximum force in kN

m = percentage of material passing through sieve 2.36mm at the maximum force

3.1.4 Aggregate Impact Value (AIV)

This test provides vital information on the impact resistance of the aggregates subjected to constant blows of load. The test was performed according to BS 812-112 (1990). Figure 3.1 shows the AIV setup. Three samples each of POC coarse and gravel were prepared for this test. The aggregate size was between 10 to 14 mm (prepared using a sieve). The specimens were oven dried for $105 \pm 5^\circ\text{C}$ for not more than 4 hours. They were then let to cool under room temperature. The holding cup was filled with aggregates until it overflowed and was subjected to 25 blows from a height of 50mm above the aggregates. The excess aggregates were removed by rolling the tamping rod across the holding cup. The impact machine is allowed to rest on top of the floor or block to ensure that the vertical guide column is in place. The hammer was raised up to $380 \pm 5\text{mm}$ above the upper level of aggregates on the holding cup before releasing to allow free fall. The aggregate in the holding cup was subjected to 15 blows. The crushed portions of the aggregates in the cup were then transferred to a clean tray. A

rubber mallet was used to knock the sides of the cup to ensure all the aggregates are collected on the tray. The fine aggregates which were still intact or adhered to the surface were removed by using a stiff brittle brush. The mass of tray and aggregates was taken and the net weight of aggregates recorded (M_A). The crushed aggregates were then sieved (mesh size of 2.36mm) whereby the portions that passes and retained were recorded as M_B and M_C , respectively. If the initial mass of the sample (M_A) and total sieved portions (M_B and M_C) varied by more than 1g, the test was discarded and repeated. The aggregate impact value then calculated as below.

$$AIV = \frac{M_B}{M_A} \times 100\% \quad (8)$$

where M_A = initial mass of the test sample (g)

M_B = mass of the sample passing through 2.36mm sieve (g)



Figure 3.1: Aggregate impact value test setup

3.1.5 X-Ray Fluorescence

X-ray fluorescence is one of the important tests that provide the chemical elements of the materials used. This test was performed at YTL research laboratory, Port Klang using Philips PW 1480 X-ray spectrometer and a Philips PW 1570 samples charger. Major chemical elements such as Na, Mn, Ti, K, P, Mg, Al, Fe, S, Si and Ca were

characterised from this test. Cement and POC powder were analyzed using this test method where the samples were ground in the range of 20 to 30 microns. Loss of ignition was obtained when the water crystals containing water elements and organic carbons were eliminated by subjecting the samples to high temperature (1000°C).

3.1.6 X-Ray Diffraction

The crystalline phases of the raw materials used in this study such as cement and POC powder were characterized using semi-quantitative X-ray diffraction method. The test specimens were sieved using a 75 µm sieve prior to the analysis. A monochromatic x-ray radiation which was subjected to the crystals diffracts at different angles compared to the original source. The degree of diffraction of the specimens subjected to radiation was obtained through the function of two theta (2θ) with a diffractometer. The compounds obtained were compared to the available intensities and spacings of standard diffraction database. This test was performed at School of Materials Mineral Resources Engineering, Universiti of Sains Malaysia using a Philips X'Pert diffractometer.

3.2 Mix Design Development

Since POC characteristics differ from ordinary aggregates, the basic mix design process was modified to provide the most optimum performance for SCC. Preliminary trials were carried out on the aggregates and the fresh properties to understand the need for a new mix design method. Together with the preliminary trials, additional tests were done to assess the effect of using POC in conventional concrete. The highly porous and irregular nature of POC aggregates may reduce the flow ability of the mix which indicates that a modification in the mix design is required. Fresh SCC exhibits poor self-compacting properties when a conventional mix proportioning technique was used. This clearly shows that most of the aggregates take up the available powder content to reduce

the self-compactability property. The new proportioning method must have the capability to cater the demand of excess paste due to porous nature of POC aggregates to ensure sufficient free paste is available to satisfy the passing and filling ability. Most of the currently available particle packing (PP) methods are focussed on the particle shape and size models whereby only some of them were involving the void volume. Taking that into account, the proposed method was modified by incorporating the actual void volume for a combination of aggregates. Indirectly this volume represents the paste volume that will be required to coat and lubricate the aggregate particles to provide the SCC properties. Figure 3.2 shows the coating of binders into the pores during the concrete mixing process. The need for additional paste volume to create SCC properties was established through correcting lubrication factor (CLF). Figure 3.3 shows the complete flow chart used in obtaining a mix proportion using PP method. Table 3.1 tabulates the ratio of aggregate combinations for PP determination.

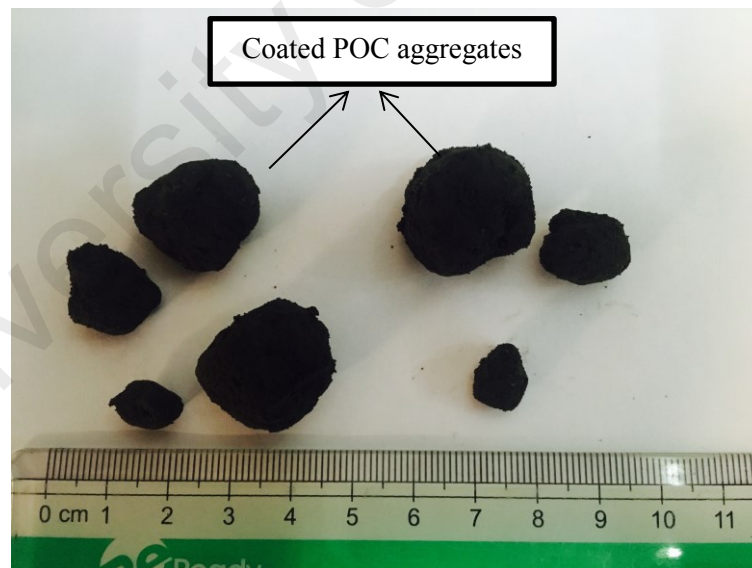

Figure 3.2: Coating of binders into pores during mixing process

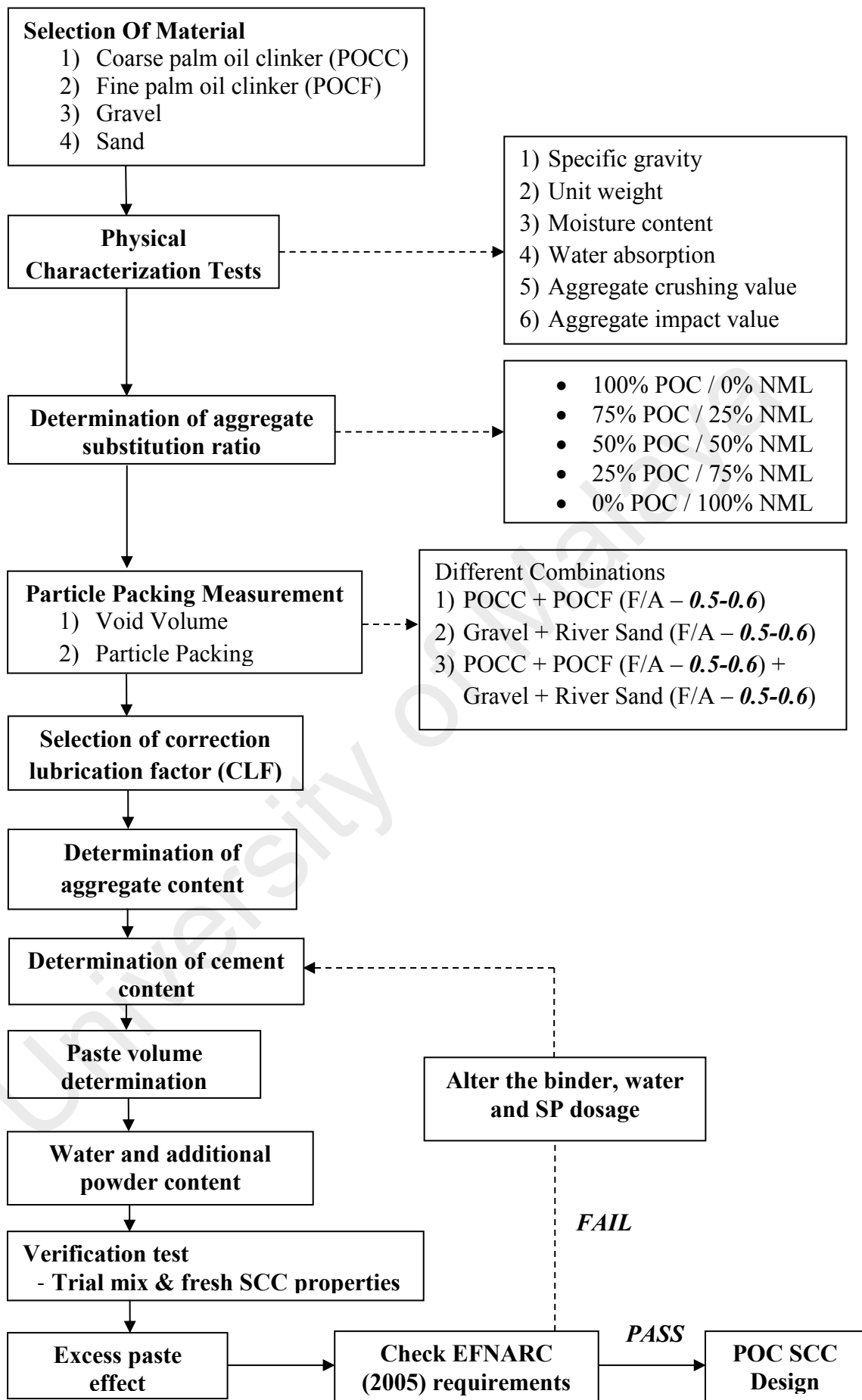

Figure 3.3: Flowchart of mix design process

Table 3.1: Ratio of aggregate combinations for PP determination

Fine Aggregate Ratio	Mix proportion	Ratio (by volume)			
		Coarse Aggregate		Fine Aggregate	
		POC Coarse	Gravel	POC Fine	River Sand
0.5	POC 0	0.500	0.000	0.500	0.000
	POC 25	0.375	0.125	0.375	0.125
	POC 50	0.250	0.250	0.250	0.250
	POC 75	0.125	0.375	0.125	0.375
	POC 100	0.000	0.500	0.000	0.500
	POC S	0.500	0.000	0.000	0.500
	POC G	0.000	0.500	0.500	0.000
	POC C (10-14)	0.500	0.000	0.000	0.500
	POC C (5-10)	0.500	0.000	0.000	0.500
	POC G (10-14)	0.000	0.500	0.000	0.500
POC G (5-10)	0.000	0.500	0.000	0.500	
0.6	POC 0	0.400	0.000	0.600	0.000
	POC 25	0.300	0.100	0.450	0.150
	POC 50	0.200	0.200	0.300	0.300
	POC 75	0.100	0.300	0.150	0.450
	POC 100	0.000	0.400	0.000	0.600
	POC S	0.400	0.000	0.000	0.600
	POC G	0.000	0.400	0.600	0.000

*POC 100 – 100% replacement of POC aggregates

*POC S - Replacement of gravel with POC coarse only

*POC G - Replacement of sand with POC fine only

*POC G (10-14) - Replacement of sand with POC fine only with 10-14mm aggregate size

3.2.1 Determination of Particle Packing (PP)

PP method was analysed and experimented in depth to ensure it will be easily assessable and understandable to every researcher taking up SCC. This is to ensure the long lasting and further improvement of this method in future. Although it was catered to absorb the special characteristics of POC particles, generally the method will definitely permit for designing conventional and highly fluid concrete. This flexibility established a wide range of design method which allows the end users to choose their required type of concrete

3.2.1.1 Phase 1

All the aggregate particles are checked to ensure they have been soaked in water for 24 hours. They were later brought into the SSD condition.

3.2.1.2 Phase 2

A clean and dry baseplate is prepared for mixing the aggregate. The combination of aggregate is prepared on the baseplate, as per the ratio in Table 3.1. They were thoroughly mixed using a scoop and trowel for five (5) minutes. Once a homogenous mixture of aggregate was achieved, it was later placed into the PP container in a loosely packed state. The container is checked to ensure that it was clean from any type of impurities.

3.2.1.3 Phase 3

Clean water was prepared of known volume. It was checked to ensure that it is warm and at room temperature to maintain the average density of water. Subsequently, the water was poured slowly into each corner of the container filled with aggregate. Figure 3.4 depicts the schematic diagram for determining the PP values.

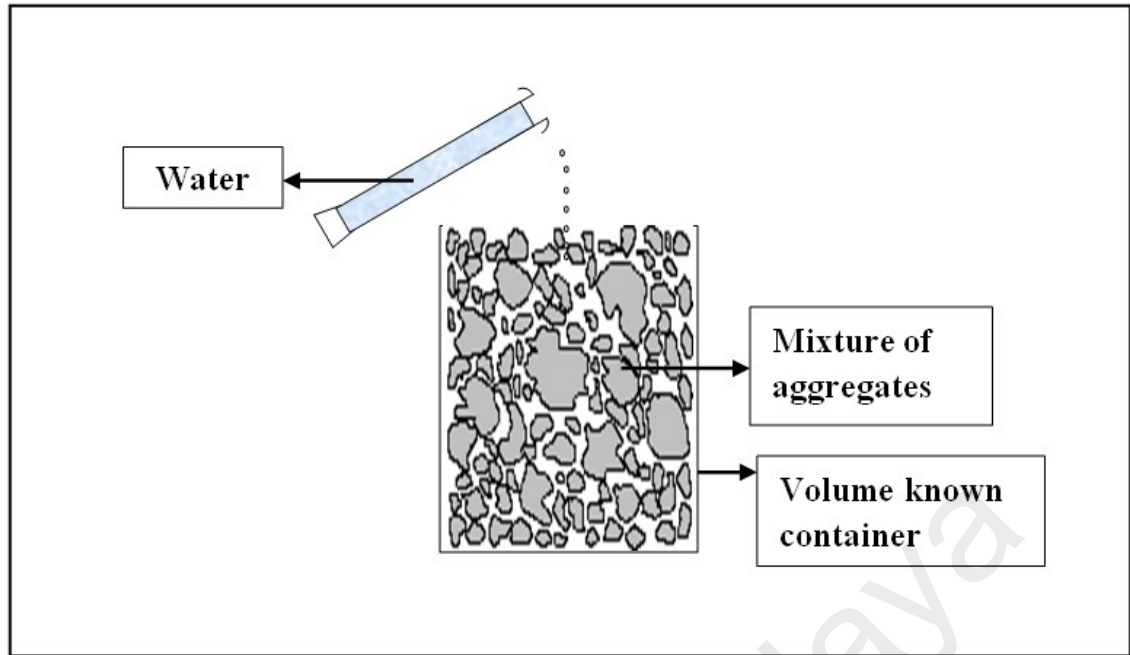

Figure 3.4: Schematic diagram of PP test



Figure 3.5: Particle packing test set-up

3.2.1.4 Phase 4

Once the water level reaches the top surface of the container, the time on the stopwatch was started. The water level was checked consecutively every 30 seconds for a period of 2 minutes. This is basically to allow for saturation of water into the pores on the POC aggregate. Water was constantly added if there is a reduction in water level. For complete ordinary natural aggregate substitution, this process was also carried out to ensure the same level of consistency. The amount of water utilized represents the

total amount of voids recorded. The obtained values were then converted into PP through a series of calculation as outlined in section 3.2.2.

3.2.2 Application of Particle Packing (PP) Values for Mix Design

The PP values obtained for each particular mix are determined for its paste volume. Since the fine aggregate/total aggregate (F/A) ratio and POC substitution ratio varies, the paste volume requirement for each mix will differ accordingly. The basic idea of this method is to ascertain the void volume between aggregates which will provide the paste volume that is required. However, consideration has to be given to the paste volume determined as it would be the minimum paste volume required. This value caters for only the coating and small amount for lubrication between the aggregates. As the aggregates are intact with each other during this test procedure, the values obtained may be suitable for concrete with lower flowability or to be more precise conventional concrete. As this study mainly focuses on SCC, the quantity of paste volume is highly dependent on the additional powder material which plays a vital role to create the passing and filling ability. Basically to design SCC, there are no direct and exact methods of proportioning. Currently, a few guidelines proposed by other researchers and organization are being utilised to design SCC mix proportion. Therefore fine adjustments after acquiring the basic proportion are vital to get the best SCC properties. To add to their contribution, a new mix design approach is proposed through PP method.

In this process, first the basic volume and aggregate content are determined from a fixed aggregate ratio proportion. Void volume for each mix represents the paste volume that will be required. Consideration was given to POC aggregates which are porous since it will affect the amount of free paste available to provide the lubrication between aggregate and rolling capability. Rolling capability refers to the ability of the aggregates

to flow or move on its own weight with the help of the available paste. The substantial amount of pores within the aggregate skeleton affects the free paste available for aggregate to satisfy both these criteria. Hence, an increase in paste volume may be required to compensate for the loss of paste within the aggregate which will be determined through trials. CLF is applied to PP values to increase the paste volume. This not only fulfills POC aggregates for better flow ability and passing ability criteria but could also promote enhanced hardened properties. The procedure for application of PP values and complete mix design are outlined in Appendix A.

3.3 Fresh Self-Compacting Concrete (SCC) Properties Test

The fresh SCC test was performed according to European Federation of National Association Representing Concrete EFNARC (2005) standard. Four different criteria or classes were evaluated to ensure the concrete meets the requirements for SCC as stipulated in the standard. The tests include slump flow, viscosity, passing ability and segregation resistance. Mixing process plays a vital role in giving different flow characteristics of SCC. Taking into account the porous nature of POC aggregates, importance was given to ensure the aggregates are coated to enhance the flow properties. Figure 3.6 shows the mixing procedure for POC SCC. The time frame of material addition plays an important role in achieving a stable SCC. Figure 3.7 shows the vertical concrete mixer used for SCC production.

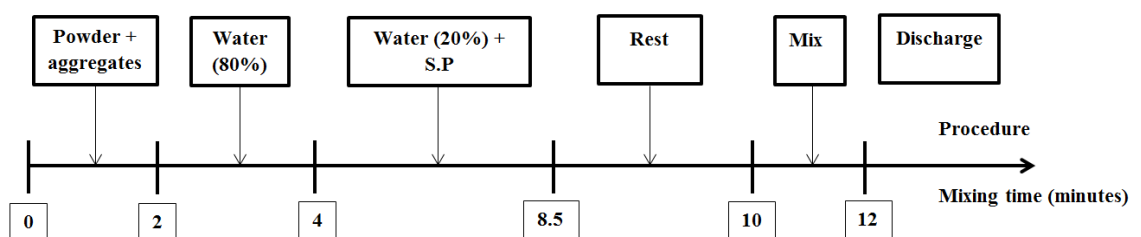

Figure 3.6: Mixing procedure for POC SCC



Figure 3.7: Vertical concrete mixer

3.3.1 Slump Flow Test

The slump cone and base plate were prepared as per EN 12350-2. Figure 3.8 shows a base plate used to determine the slump flow of SCC. The base plate was marked with 200 mm and 500 mm diameter circles. The slump cone was placed on the base plate on the 200 mm diameter circle. A cone collar was used to avoid spilling of concrete onto the base plate. The SCC mixture was then filled into the cone until the top of the cone without any rodding or tamping. Then the cone was lifted vertically to allow the concrete to flow across the base plate. The time taken for the SCC mixture to travel from the edge of the 200 mm diameter circle to the 500 mm diameter circle was recorded as T_{500} time. The flow spread of the mixture was determined by measuring the diameter at right angles. Table 3.2 shows the classification of slump flow specified by EFNARC (2005).

Table 3.2: Slump flow classes (Source : EFNARC (2005))

Class	Slump flow diameter (mm)
SF1	550 to 650
SF2	660 to 750
SF3	760 to 850

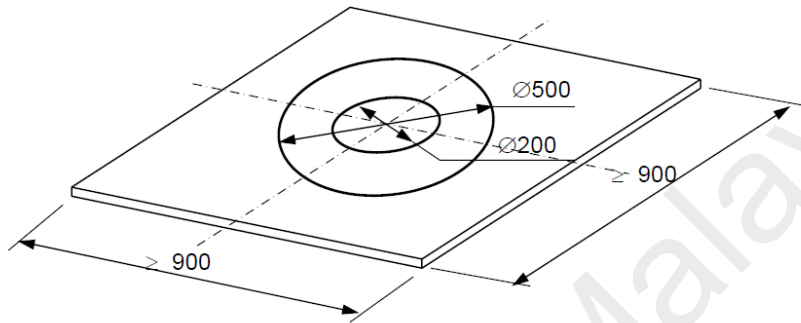

Figure 3.8: Base plate for slump flow test (Source :EFNARC (2005))

3.3.2 V-funnel & T₅₀₀ Test

The test evaluates the viscosity and filling ability of the SCC mixture. A V-funnel was fabricated according to the dimensions provided by European Federation of Specialist Construction Chemicals and Concrete Systems (EFNARC). Figure 3.9 shows the dimension of a V-funnel used in this study. Figure 3.10 depicts the V-funnel test set-up in the laboratory. Before the test, the V-funnel bottom gate is closed and the side surfaces were dampened. Next, the fresh mix was poured into the V-funnel without any tamping or rodding. Excess concrete on the surface of the funnel was stroked off with a trowel. After 10 ± 2 s, the gate was opened to allow the concrete mixture to flow into a container placed at the bottom of the funnel. The V-funnel time taken for the concrete mix to flow out of the funnel until the first glimpse of the receiving container was noted. Table 3.3 tabulates the viscosity classes stipulated by the standard.

Table 3.3: Viscosity classes (Source : EFNARC (2005))

Class	Time to reach 500mm slump diameter, T_{500} (s)	V-funnel time, (s)
VS1/VF1	≤ 2	≤ 8
VS2/VF2	≤ 5	9 to 25

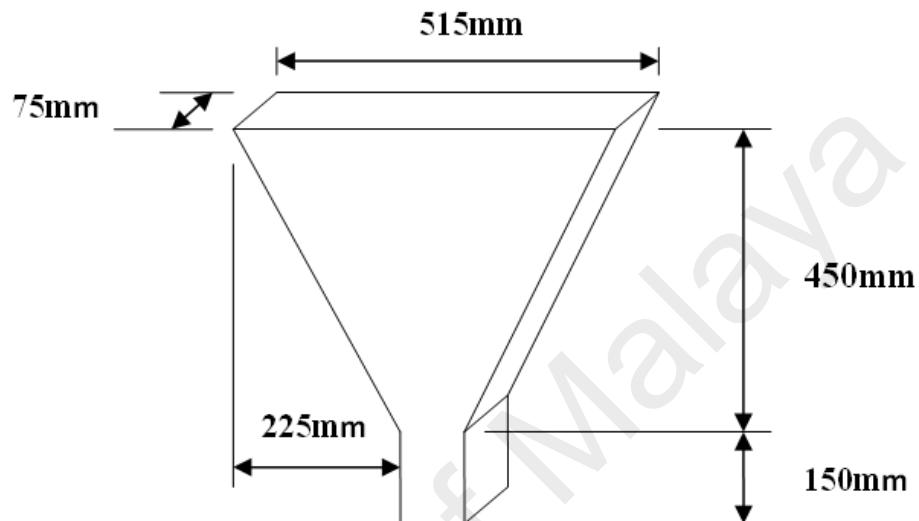

Figure 3.9: Dimensions of V-funnel (Source : EFNARC, 2005)



Figure 3.10: V-funnel test set-up

3.3.3 L-box Test

The principle of this test is to measure the “passing ability” of the SCC mixture when it flows against narrow openings of a formwork or an obstruction of reinforcing steel bar. The difference in the height level of the concrete in both sections of the concrete categorizes the passing ability class. The test was performed according to EFNARC

(2005). Figure 3.11 shows the dimension of an L-box used in this study. Meanwhile, Figure 3.12 depicts the L-box test set-up in the laboratory. The gate was closed completely before the fresh SCC mixture was poured into the filling hopper and allowed to stand for 60 ± 10 s. The gate was then opened to allow SCC mixture to flow through the smooth bars. When the mixture stopped moving, the vertical distance between the top of the concrete and top of the L-box horizontal section were measured. The same method was used to determine the height of the concrete behind the gate. Passing ability classes are tabulated in Table 3.4.

Table 3.4 : Passing Ability classes (Source : EFNARC (2005))

Class	Passing Ability
PA 1	≥ 0.8 with two rebars
PA 2	≥ 0.8 with three rebars

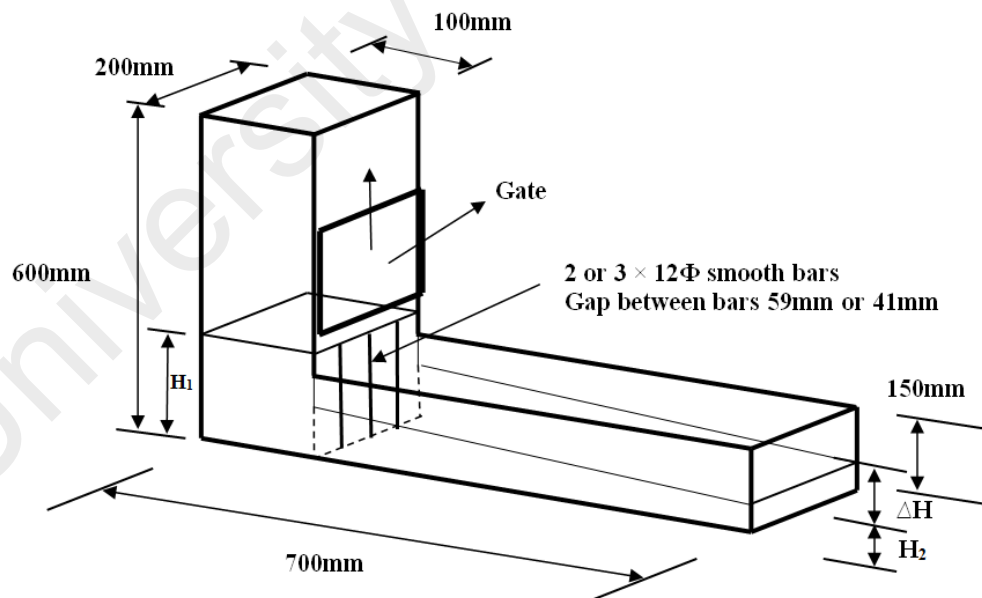

Figure 3.11: Dimensions of L-Box apparatus (Source : EFNARC, 2005)



Figure 3.12: L-box test set-up

3.3.4 Sieve Segregation Test

Sieve segregation resistance test provides an indication on the possible rate of segregation of a SCC mix. Concrete with a volume of 10 ± 5 L is prepared and allowed to stand without disturbance for 15 ± 0.5 min. A pan was prepared and its mass was taken (W_p g). Then the sieve was placed on top of the receiver and their mass was recorded. At the end of the standing period, any bleeding observed on the surface of the concrete was checked. 4.8 ± 0.2 kg of concrete was then poured into the sieve center. The mass of concrete poured was recorded (W_c). The concrete was let to be on the sieve for 120 ± 5 s before the sieve was removed vertically. The mass of the concrete passing through the sieve was then taken as W_{ps} . Table 3.5 tabulates the sieve segregation classes as outlined by the standard. The segregation resistance was calculated based on Eq.9.

$$SR = \frac{W_{ps} - W_p}{W_c} \times 100\% \quad (9)$$

where W_{ps} = mass of concrete passed the sieve;

W_p = mass of sieve receiver;

W_c = mass of concrete poured

Table 3.5 : Sieve Segregation Classes (Source : EFNARC (2005))

Class	Segregation Resistance (%)
SR 1	≤ 20
SR 2	≤ 15

3.3.5 Rheology of Self-Compacting Concrete (SCC) and Mortar

The rheological behaviour of SCC and SCM were evaluated using rheometers. A rheometer developed by International Centre for Aggregate Research (ICAR) was used to characterize the rheological characteristics of SCC. Figure 3.13 shows the setup of the ICAR rheometer used in this study. The yield stress and plastic viscosity of the SCC mix can be obtained through this test. The static yield stress was calculated when the vane is allowed to rotate at constant speed of 0.025 rev/s. The maximum torque obtained during this increase in torques indicated the static yield stress. On the other hand, the dynamic yield stress and plastic viscosity were determined through the flow curve test. During this test, the vane speed is rotated at a high speed before reduced in steps at a regular time interval. The average torque and speed were measured at every interval. On the other hand, the rheological behaviour of SCM incorporating POC powder and POC fine was obtained using a Brookfield rheometer. Figure 3.14 shows the setup of the Brookfield rheometer used in this study. A vane spindle (V30-15) with

a shear range of 120 to 4000 Pa was specifically selected to cater the high viscosity nature of mortar. This rheometer collects and analyses data using software called 'Rheo3000'. The software provides detailed correlation with a few types of regression curves such as Bingham, Casson, Ostwald, HershelBulkley and SteigerOry.

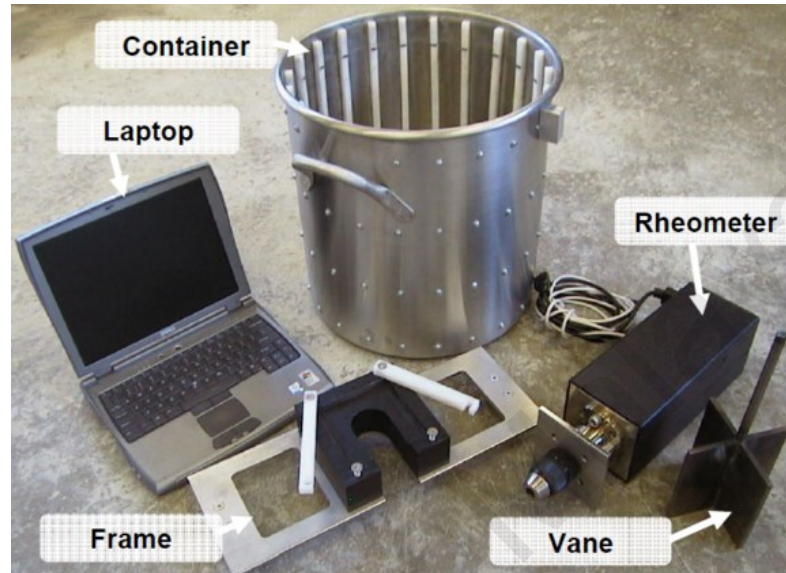

Figure 3.13: An ICAR rheometer set-up



Figure 3.14: A Brookfield rheometer with Rheo3000 software

3.4 Hardened Properties of Self-Compacting Concrete

3.4.1 Density

The test was carried out according to BS EN 12390-7 (2009). Demolded cubes of 100 mm³ were measured for its mass and dimension. The length, width and height of

the specimens were measured using a Vernier caliper to calculate its volume. Each time three specimens were taken to obtain an average value. The density was calculated through Eq.10.

$$\text{Density (kg/m}^3\text{)} = \frac{\text{Mass (kg)}}{\text{Volume (m}^3\text{)}} \quad (10)$$

3.4.2 Compressive Strength

Samples of 100 mm³ cube were prepared to determine the strength of SCC at different ages of 1, 3, 28, 56, 90, 120 and 180 days. Figure 3.15 shows the 100mm cube gang molds used in this research. 50mm cube samples were used to test for strength properties of SCM samples. The test was carried out according to BS EN 12390-3 (2009). The structural efficiency (SE) was calculated based on the 28 day compressive strength values using Eq.11.

$$\text{Structural efficiency (SE)} = \frac{\text{Compressive strength (28 days)}}{\text{Density}} \quad (11)$$

Before carrying out this destructive test, the density and UPV values of the samples were determined. Three cube samples were tested at each age to increase the consistency of the results. Figure 3.16 shows the compressive strength machine used which was produced by Engineering Laboratory Equipment Limited (ELE).



Figure 3.15: 100mm cube gang moulds used in this study



Figure 3.16: Compressive strength test machine

3.4.3 Ultrasonic Pulse Velocity Test (UPV)

This test is a non-destructive test (NDT) method which determines the rate of pulse travelling across the samples to provide vital information on the packing level, voids and any irregularities in the concrete specimens. 100 mm cube and 50 mm cubic specimens were prepared for concrete and mortar respectively to carry out the test.

“PUNDIT” UPV test machine was utilised in this study. This test was conducted based on BS EN 12504-4 (2004). The UPV test was carried out at 3, 28, 56, 90, 120 and 180 days. This non-destructive test (NDT) was conducted on each cube prior to the strength test. A conductive UPV gel was applied to the surface of the transducers to impose better contact between the surfaces to enhance the pulse transfer. The time taken for the pulse to travel from a transmitter to the receiver across the concrete cube gives the intensity of pulse transfer. The UPV values are calculated according to the formula below. Figure 3.17 shows the ‘PUNDIT UPV’ test setup available in the laboratory. Figure 3.18 shows the UPV test for a concrete specimen. Table 3.6 and Table 3.7 show the different classifications used to characterize the concrete or mortar based on the UPV values obtained. The UPV values can be obtained using Eq.12.

$$\text{UPV (km/s)} = \frac{\text{Distance (km)}}{\text{Pulse transfer time (s)}} \quad (12)$$



Figure 3.17: ‘PUNDIT’ UPV test machine



Figure 3.18: UPV test for concrete specimen

Table 3.6: Classification of the ultrasonic pulse velocities (Anon, 1979)

Class	V (m/s)	Definition
1	<2000	Very low velocity
2	2500 - 3500	Low velocity
3	3500 - 4000	Middle velocity
4	4000 - 5000	High velocity
5	>5000	Very high velocity

Table 3.7: Concrete classification based on UPV values (Malhotra, 1976)

Pulse Velocity (m/s)	Concrete classification
$V > 4575$	Excellent
$4575 > V > 3660$	Good
$3660 > V > 3050$	Questionable
$3050 > V > 2135$	Poor
$V < 2135$	Very poor

3.4.4 Flexural Strength

Flexural strength test was conducted based on BS EN 12390-5 (2009). Concrete prisms of 100 mm × 100 mm × 500 mm were prepared for this test. It involves a detailed study on the fractured portion of the concrete prisms. The measurements across the cracks formed were taken after the flexural test. A similar test setup was employed to test mortar prisms of size 40 mm × 40 mm × 160 mm. The test was carried out as outlined by ASTM C348 (2014). Tests were carried out at 28, 90 and 180 days to ascertain the flexural behaviour of the concrete. Figure 3.19 shows the setup of flexural strength machine in the laboratory by ELE. The flexural strength was obtained through Eq.13.

$$\text{Flexural Strength, } R = \frac{PL}{bd^2} \quad (13)$$

where R = flexural strength (MPa)

P = maximum applied load on the specimen (kN)

L = span length (mm)

b = width of the specimen (mm)

d = depth of the specimen (mm)



Figure 3.19: Flexural strength test machine

3.4.5 Splitting Tensile Strength

This test was conducted based on BS EN 12390-6 (2009). Cylinder samples of 100 mm in diameter and 200 mm in length were prepared for this test. Load was applied across the horizontal length of the samples to evaluate the tensile strength required. Tests were performed at 3, 28, 90 and 180 days to determine the tensile performance of concrete in this study. Figure 3.20 shows the cylinder molds used for this test. The splitting tensile strength values can be determined through Eq.14.

$$\text{Splitting tensile strength, } f_{cs} = \frac{2P}{\pi dL} \quad (14)$$

where f_{cs} = splitting tensile strength

P = maximum applied load on the specimen (kN)

L = cylinder length (mm)

d = cylinder diameter (mm)



Figure 3.20: Splitting tensile strength molds (200 mm × 100 mm diameter)

3.4.6 Modulus of Elasticity

Cylinder samples of 150 mm in radius and 300 mm in length were utilised for this test. The static modulus elasticity of the concrete was established through the relationship between stress and strain. The test was conducted according to BS EN 12390-13 (2013). Tests were performed on 28, 90 and 180 days to ascertain the elastic behaviour of concrete in this study. Figure 3.21 shows the molds used for the modulus of elasticity test. The elasticity values can be obtained using Eq.15.

$$\text{Modulus of elasticity, } f_{ce} = \frac{\sigma}{\epsilon} \quad (15)$$

where σ = unit stress

ϵ = unit strain



Figure 3.21: Modulus of elasticity molds (300mm × 200mm diameter)

3.4.7 Drying Shrinkage

Three prisms of 100 mm × 100 mm × 500 mm were prepared for this test. ‘Demac’ gauge points were attached to the prism at a distance of 200mm between each other on

the three smooth faces of the concrete. These points are attached to the concrete as soon as the concrete is demolded. The specimens were kept in a normal room temperature condition and were air cured. Shrinkage readings were taken at 1, 2, 3, 7, 14, 21, 28, 56, 90, 120, 150, 180, 210, 240, 270, 300, 330 and 365 days respectively. The change in length was measured using an extensometer which has a precision up to 0.001 strains. The samples were all placed under normal room temperature and humidity level to replicate the actual construction site environment. The shrinkage values are determined through Eq.16.

$$\text{Shrinkage} = \frac{\text{length difference}}{\text{original length}} \quad (16)$$

3.5 Durability Tests

Long term behaviour of concrete is vital to determine the quality of concrete. With the utilisation of waste, the extended properties of SCC against durability tests are vital to ensure the sustainability of the concrete over a prolonged period of time. Incorporation of POC needs an extensive test on durability properties as it is new and novel material to be utilised for the construction industry.

3.5.1 Rapid Chloride Penetration Test (RCPT)

The amount of chloride ingress in concrete is an important aspect that must be taken into consideration. It determines the quality of the concrete with the establishment of chloride content in concrete. “PROOVE-it” rapid chloride penetration test (RCPT) was used to ascertain the amount of chloride ingress into the samples. The test was carried out according to ASTM C1202 (2012). Figure 3.22 shows the setup for the RCPT test. Before the test, the specimens have to be prepared and conditioned according to the standard. Cylindrical concrete specimens of size 100 mm in diameter

and 50 mm in height were prepared for this test. These concrete samples were then placed in the vacuum desiccator. Few drops of silicon oil are placed on the edge of the cover lid before placing it tightly against the desiccator. This will make sure the desiccator is fully in vacuum throughout the immersion period. Then the connection hose from the lid was connected to the vacuum pump. The valve and the pump are then switched on. The vacuum condition was maintained for three (3) hours. The vacuum pump was then turned off. The second hose are connected to the lid on the desiccator and placed into the container containing aerated water. Aerated water was required to ensure greater permeation rate into the concrete specimens. It was prepared by allowing the water to boil for half an hour which will remove the air content.

The aerated water was allowed to flow into the desiccator by turning on the valve at a slower rate and ensured to completely submerge the cylindrical specimens. Once done, the second valve was closed and the primary hose was opened before switching on the vacuum pump. The pump was let to run for one (1) hour before be turned off. The specimens were allowed to soak in water for a span of 18 hours. Then, the concrete cylinders were placed between the two cells containing NaOH and HCl solutions, respectively. Figure 3.23 shows the schematic setup of a cell used in this study. The amount of charge in coulombs that passes through the specimens subjected to 60V potential difference was measured for each replacement rate. The samples were tested for RCPT at 180 and 365 days respectively. The late age testing of the samples is vital to assess the real long term behaviour of the concrete. Table 3.8 shows the limit provided by ASTM C1202-12.



Figure 3.22: Rapid chloride penetration test vacuum pump and dessicator (Adapted from PROOVE'it Instruction and Maintenance Manual)

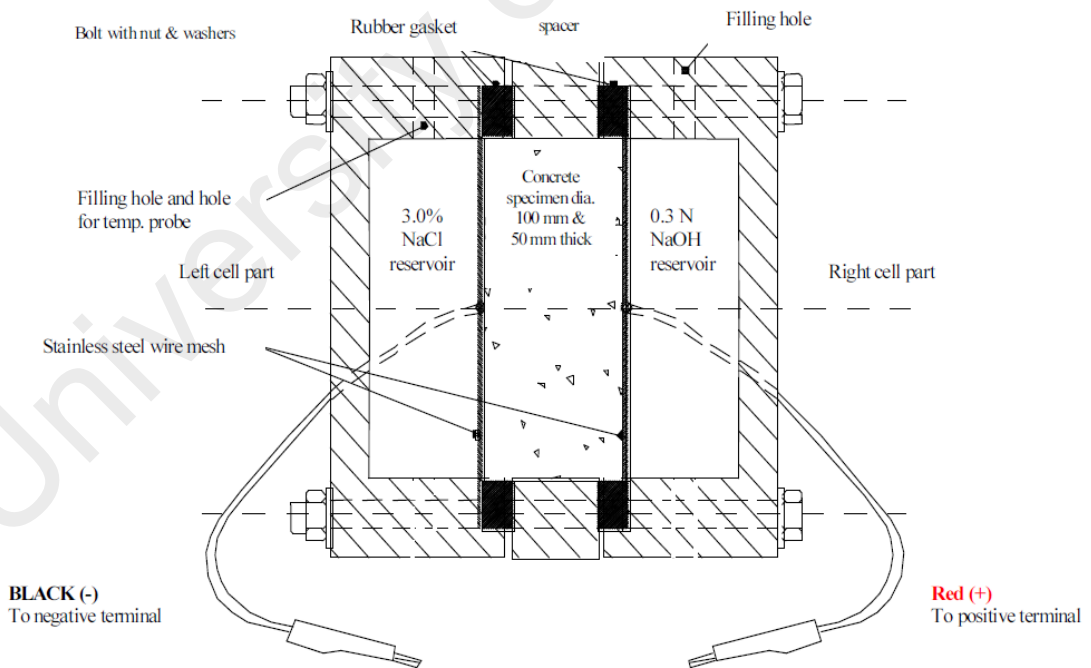

Figure 3.23: Rapid chloride penetration test setup (Adapted from PROOVE'it Instruction and Maintenance Manual)

Table 3.8: Chloride ion permeability based on charges passing (ASTM C1202, 2012)

Coulombs	Chloride Ion Permeability
>4000	High
4000-2000	Moderate
2000-1000	Low
1000-100	Very low
<100	Negligible

3.5.2 Sulfate Attack

This test measures the sulfate resistance of SCC, SCM and microconcrete specimens. 10 mixes (0.5 F/A and 0.6 F/A) were selected based on their mix proportion to ensure every range of POC replacement is studied under sulfate attack. The mixes are POC 100, POC 50, POC 0, POC S and POC G. These mixes were selected taking into consideration the higher and lower ends of the strength and durability properties. For concrete specimens, 100mm³ cubes were prepared for this test and were water cured for 28 days. Subsequently, they were placed in 5% of magnesium sulfate (MgSO₄) solution. Figure 3.24 shows the sulfate curing tank used in this study. These cubes were measured for its dimension and mass before sulfate cured. The solution was renewed every 15 days to ensure the consistency of the sulfate ion presence. Three cycles of wetting and drying were carried out at an interval of 37 days. The weight loss and compressive strength was measured at regular intervals at the end of each cycle. The strength loss or gain was evaluated to understand the effect of sulfate on POC incorporated specimens. While for SCM mixes, the same sulfate condition and testing procedure are followed with 50mm³ cubes.



Figure 3.24: Sulfate curing tank

3.5.3 Water Absorption

Water absorption of concrete plays a vital role to exhibit the porosity within the concrete matrix. Addition of lightweight aggregates may affect the capillary suction properties due to the high water absorption properties of POC aggregates. Besides that, the poor connectivity between aggregates due to the aggregate shape and size may also induce greater absorption characteristics due to the higher amount of voids. For this test, three cube specimens of 100mm^3 were used. Before testing, the samples were oven dried to achieve a constant mass at a temperature of 105°C . Secondly, they were cooled to room temperature in a desiccator for further 24 hours. Then, the samples were immersed in a container filled with water. All the specimens were made sure to be immersed completely under water. They were removed from water after 24 hours before being wiped with cloth to achieve SSD condition. The weight of the samples was then taken. Eq. 17 was used to determine the water absorption of the specimens.

$$\text{Water absorption (\%)} = \frac{M_a - M_o}{M_o} \times 100 \quad (17)$$

where M_a = mass of the specimen after immersion (g)

M_o = mass of the oven dry specimens specimen (g)

3.5.4 Sorptivity Test

The pore structure connectivity of a concrete specimen can be determined through sorptivity test. Micro pores that exist within the aggregate and binding agents allows for water intake through the capillary that are present. The higher rate of water intake is highly related to larger pore structures that are available within the concrete structure. In this study, POC aggregates and powder materials which were irregular in shape and having different sizes may cause some effects to the water capillary intake rate. Through this test, the porosity of the concrete can be assessed and determined. Three cylindrical specimens of size 50 mm in height and 100 mm in diameter for each mix proportion were prepared for this study. Figure 3.25 shows the schematic diagram of sorptivity test setup, meanwhile Figure 3.26 shows the test setup. Before the test, they were placed in oven for 72 hours at a temperature of $105 \pm 5^\circ\text{C}$. Then they were removed from the oven and placed in a desiccator to cool down for 24 hours. The ends of the cylindrical samples which are to be immersed were covered with water prove silicon (adhesive) to prevent water intake through the sides of the specimens. The initial weight of each cylindrical block was measured to the nearest 0.01g with an electronic balance. An immersion tray was prepared with a few pieces of 5 mm steel rods to ensure the specimens are at a height of 5mm from the base. The water level in the tray was maintained to be within a depth of about 1mm to 2mm. Water intake rate was monitored by measuring the weight of the blocks at a regular intervals of 1, 5, 10, 20, 30, 60, 120, 180, 240, 300 and 360 minutes. Each block surface which is in contact with water was wiped thoroughly using a paper towel to ensure there are no any excess water. Once the weight was taken, the specimens were returned immediately to the immersion tray to

maintain the consistency of water intake with respect to time. A graph of $W_s(t)$ against square root of time was plotted for each mix. The sorptivity coefficient (S_{rp}) is obtained as a ratio or slope of graph $W_s(t)$ and square root of time. Eq.18 and Eq.19 can be used to determine the sorptivity values.

$$i = \frac{M_t - M_o}{Ap} \times 10^3 \text{ mm}^3/\text{mm}^2 \quad (18)$$

where i = cumulative absorption

M_t = mass of specimen at time t , (g)

M_o = mass of oven dry specimens (g)

A = cross sectional area of the surface (mm^2)

p = density of water (kg/m^3)

$$i = S\sqrt{t} \quad (19)$$

where i = cumulative absorption

S = sorptivity ($\text{mm}/\text{s}^{0.5}$)

t = time (s)

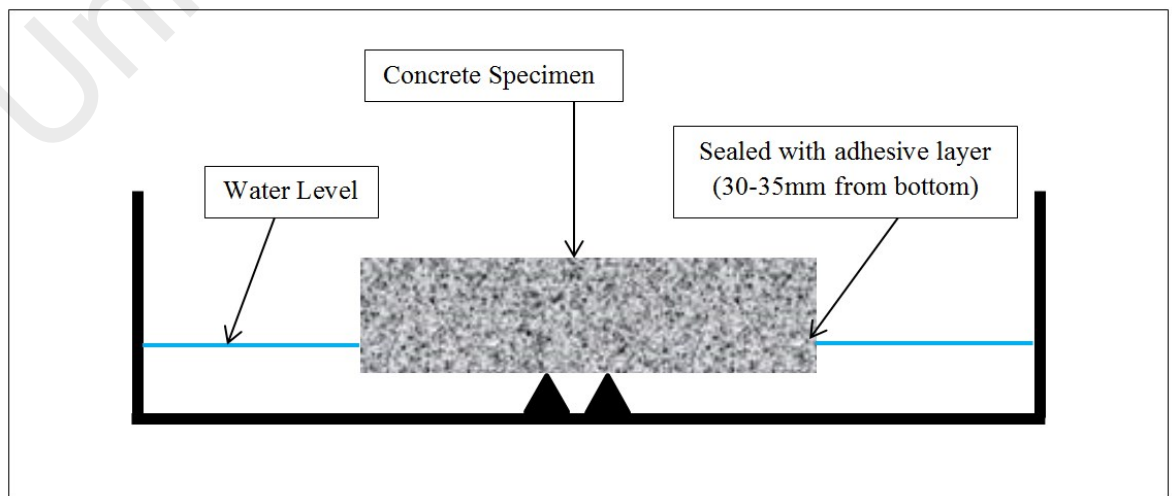

Figure 3.25: Sorptivity test schematic diagram

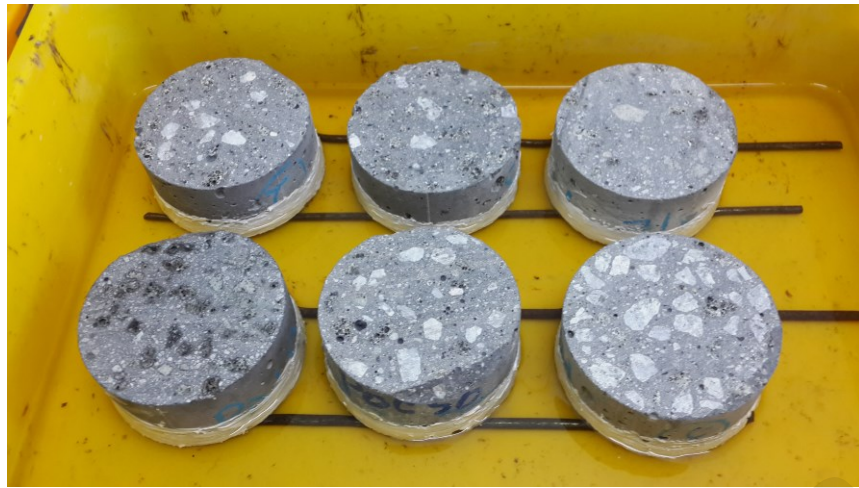

Figure 3.26: Sorptivity test set up

3.5.5 Elevated Temperature Test

This residual property test provides in depth information on the resistance of concrete and mortar specimens subjected to elevated temperature. Figure 3.27 shows a schematic temperature and load histories for steady-state temperature tests (Phan & Carino, 2000). There is a possibility of evaluating the variation in the stress and strain of the concrete samples when they are preloaded to almost 20% to 40% of the compressive strength and subsequently exposed to high temperature as depicted in (a). Meanwhile, unstressed test performed when the samples is constantly exposed to heat before being tested until failure. However, in this study the focus was given on the unstressed residual property as it provides the properties of POC only as a heat resisting material whereby the samples are heated and allowed to cool before being tested at room temperature. For mortar specimens, 50 mm cubic specimens were prepared for the mixes. While for concrete specimens, 100 mm cubic samples were used. The mass and density of the mortar specimens were taken to measure weight loss of the specimens. At the same time, control specimens from mortar and concrete were prepared to get residual strength properties. A furnace having temperature limit up to 1250°C was used in this study. The mortar specimens were placed in the furnace chamber without any loading on samples and their temperature rise was monitored every 10s to obtain a

temperature-time graph. This graph is vital to understand the rate of temperature increase per unit time. Once the required target temperature is reached, the samples were allowed to achieve a thermal equilibrium or constant condition. The samples were then cooled for 30 minutes in oven before being transferred in a desiccator. Mass loss and notable physical changes were checked on each specimen. Once the specimens have reached the room temperature, UPV and compressive strength test were carried out to determine the residual mechanical property change.

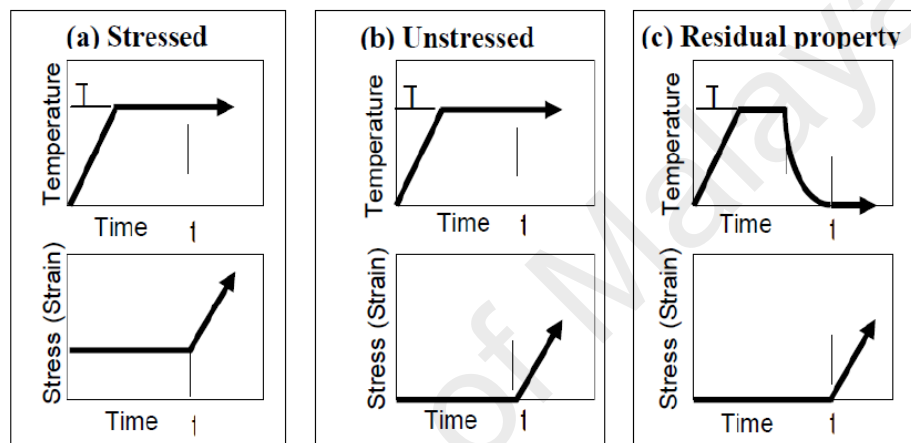

Figure 3.27: A schematic temperature and load histories steady-state temperature tests (Phan and Carino (2000))

3.6 Sustainability Assessment

As the study focuses on the evaluation of utilisation of waste materials in concrete, there is a need to assess the sustainability or environmental performance of the ‘green’ concrete. Moving parallel with global push towards green building index and importance of using waste resources in various sectors, the evaluation was made through three important components namely cost, greenhouse gas emission and energy efficiency. Although some of them remain qualitative in nature, POC introduction needs to be checked to understand the positive contribution towards these sustainability aspects.

3.6.1 Cost

A cost comparison was made taking into consideration the current market cost of materials obtained from various sources. Table 3.9 lists the market price of materials used in this study. These values are the average values obtained for a fixed period of time to ensure consistency in the cost evaluation. Besides that, these values are obtained from the current market of materials in 2015 by a detailed survey of average values as quoted by retailers including the transportation and labors cost. As for POC, the values obtained are obtained though inclusion of cost of transportation, materials and labour charges. At the current state, POC are available for very low of cost and most of them are available without any cost involved. Cost of the mixture was calculated by integrating the mix design of concrete or mortar into the current cost of materials. In addition to that, a new index system called Engineering Economical Index (ECI) was developed to study the cost effectiveness to the mechanical properties of POC concrete. The values obtained for control and maximum POC substitution would be normalized to provide a good medium or platform of comparison between conventional concrete and lightweight concrete. This would again serve as a benchmark to determine the best mix that could be used to maximize the economic and hardened concrete quality. Eq.20 was used to obtain the ECI values.

$$ECI = \frac{\text{Structural efficiency at 28 days}}{\text{Cost of the concrete mix}} \quad (20)$$

Table 3.9: Cost of materials by weight (RM/kg)

Materials	Cost (RM/kg)
Cement	0.44
Gravel	0.05
Sand	0.08
POC Coarse	0.02
POC Fine	0.02
Fly Ash	0.03
Ground granulated blast-furnace slag (GGBS)	0.03
POC Powder	0.02
Limestone Powder (LP)	0.22
Superplasticizer (SP)	15.28

3.6.2 Greenhouse Gas (GHG) Emission

Greenhouse gas emission (GHG) is an important study to understand the effect of waste materials addition towards enhancement in quality of environment. It provides an insight towards quantifying the rate of carbon discharge to our mother nature. They are obtained from a series of GHG emission factsheet provided by Mineral Products Association (2012) and DECC (2011). Similar to ECI, another index namely engineering environmental index (EEI) was introduced to assess the rate of GHG emission with respect to the mechanical properties. It would provide direct quantified values in bringing together the engineering and environmental components. Eq.21 was used to determine the values of EEI.

$$EEI = \frac{\text{Structural efficiency at 28 days}}{\text{GHG emission of the concrete mix}} \quad (21)$$

3.7 Life Cycle Assessment

As part of the environmental study on POC, a complete life cycle assessment was made to determine the effect of using this by-product in concrete instead of landfilling it. Six main criteria were considered in evaluating the LCA. They are respiratory organics, respiratory inorganics, climate change, ecotoxicity, acidification/eutrophication and fossil fuels. The LCIA was carried out using the SimaPro Software version 8.0.1 and the Eco-indicator 99 methodology. The inventory data for this special assessment was obtained from Malaysian Palm Oil Board (MPOB). Collaboration works was initiated with MPOB to evaluate the life cycle assessment of POC as the data available is up to date and is consistent.

University of Malaya

CHAPTER 4: MATERIAL CHARACTERISATION

4.1 Introduction

Studies were conducted on various parts such as fresh properties, hardened properties, rheological properties and durability. As palm oil clinker (POC) is being introduced for use in the construction industry, the aforementioned studies is required to understand its real characteristics and behaviour in concrete. POC aggregates from various states in Malaysia were characterised through a detailed feasibility study whereby the physical and chemical were scrutinized. POC powder which was incorporated as an additional powder material was also characterised thoroughly.

4.2 Material Characterisation

4.2.1 Aggregates Specific Gravity, Water Absorption and Moisture Content

Figure. 4.1 and Figure. 4.2 shows the coarse and fine aggregates used in this study, respectively. The physical characteristics of these aggregates are presented in Table 4.1, Table 4.2 and Table 4.3. It should be noted that the average specific gravity of POC coarse is only about 65% compared to gravel of similar size. Meanwhile, the specific gravity of POC fine is approximately 82% of the conventional sand used in construction. These findings suggest that POC aggregates could be a good substitute for conventional aggregates. However, the nature of POC aggregates which are porous and lightweight in nature affects the saturation rate within them. This particular characteristic is important as it determines the need for additional amount of water beyond the moisture content. Water correction is made in laboratory mixing stage taking into account both the moisture and water absorption rate.

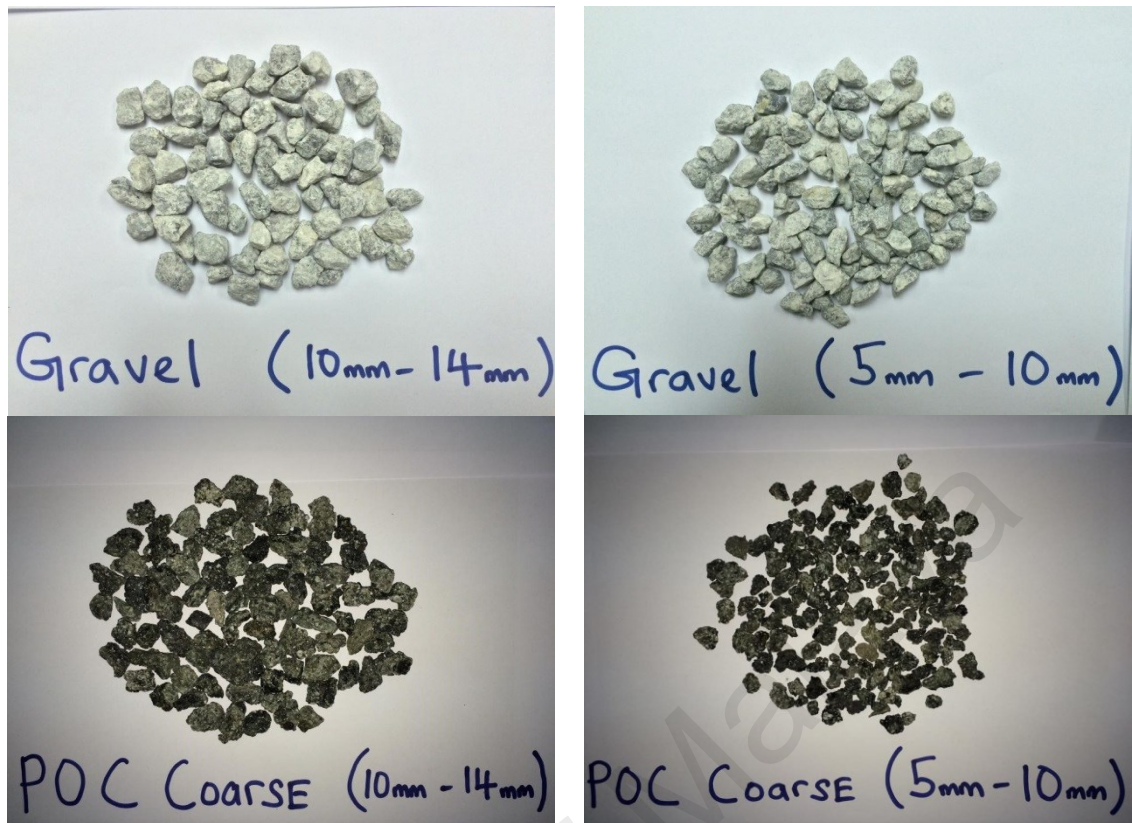

Figure 4.1: Coarse aggregates used for casting in this study

Table 4.1: Physical properties of POC coarse (coarse aggregate)

Physical Properties	POC Coarse (5mm-14mm)	POC Coarse (5mm-10mm)	POC Coarse (10mm-14mm)
Saturated surface dry (SSD)	1.73	1.87	1.72
Water absorption (%)	0.78	0.48	0.34
Moisture Content (%)	0.20	0.23	0.09

Table 4.2: Physical properties of gravel (coarse aggregate)

Physical Properties	Gravel (5mm-14mm)	Gravel (5mm-10mm)	Gravel (10mm-14mm)
Saturated surface dry (SSD)	2.65	2.64	2.63
Water absorption (%)	0.55	0.92	0.77
Moisture Content (%)	0.27	0.30	0.30

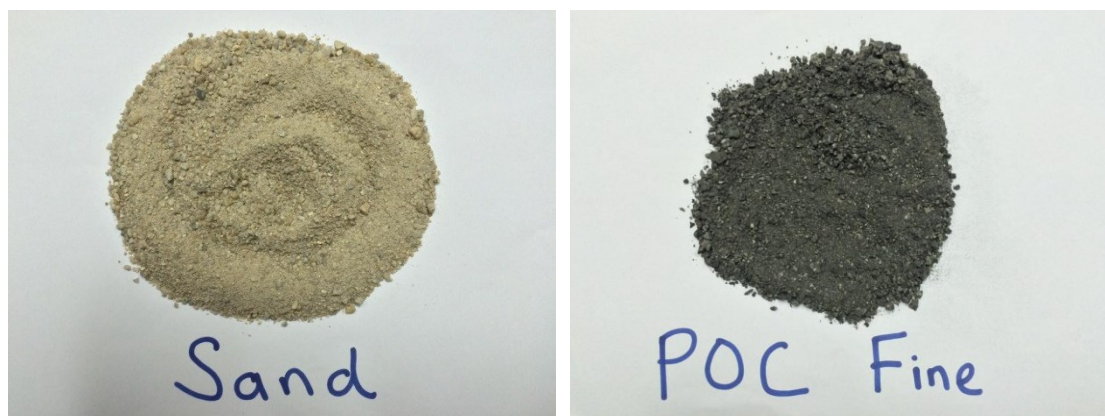

Figure 4.2: Fine aggregates used for casting in this study

Table 4.3: Physical properties of fine aggregates

Physical Properties	Sand	POC Fine
Saturated surface dry (SSD)	2.60	2.13
Water absorption (%)	1.59	5.79
Moisture Content (%)	0.07	1.68
Fineness modulus	2.58	2.71

4.2.2 POC Microstructural Analysis

Evaluation of POC structure is vital to assess the behavior of the material in concrete. As discussed earlier, particle packing (PP) method gives good indication on the amount of pores and voids that are existing within the aggregates. This affects greatly the need for extra amount of paste to ensure the flowability and passing ability of the mixes. Scanning electron microscopy (SEM) test was carried out on POC aggregates sample to check the microstructure properties besides getting some information on the possible reasons behind the effect to fresh and hardened properties. The EDX system used was of EDX Oxford. The samples were polished and precoated with gold before testing. Figure 4.3 (a) depicts the presence of large voids on the external surface of POC fines. Some of these pores are as big as 2 mm on average. These pores may be formed as a

result of pyrolysis process due to high temperature burning. Even on a larger magnification, the pores within POC are clearly visible. PP test performed on POC incorporated mixes also indirectly proved the existence of substantial amount of voids. This requires extra paste volume to substantiate the paste that would fill into the voids. PP method of mix design would be a good solution as the CLF values helped to introduce additional paste volume to create filling effect besides providing the self-compacting behaviour. Figure 4.3 (b) shows the micro voids that are present within the POC fine aggregates. As observed, the micro voids available affects the potential of having early crack propagation in concrete or mortar as it may induce a weaker region through connection of voids. As a result, these voids may provide some reduction in strength properties when incorporated in concrete. Besides that, these micro voids could also provide a decrease in the particle packing which will affect some other important hardened properties parameters. Figure 4.3 (c) depicts the SEM images for POC coarse. Meanwhile, Figure 4.4 shows the electron dispersive X-ray for micrographs on Figure 4.3, respectively. The irregularities in the surface area and texture of POC aggregates can be seen clearly besides immense voids on a smaller and larger scale.

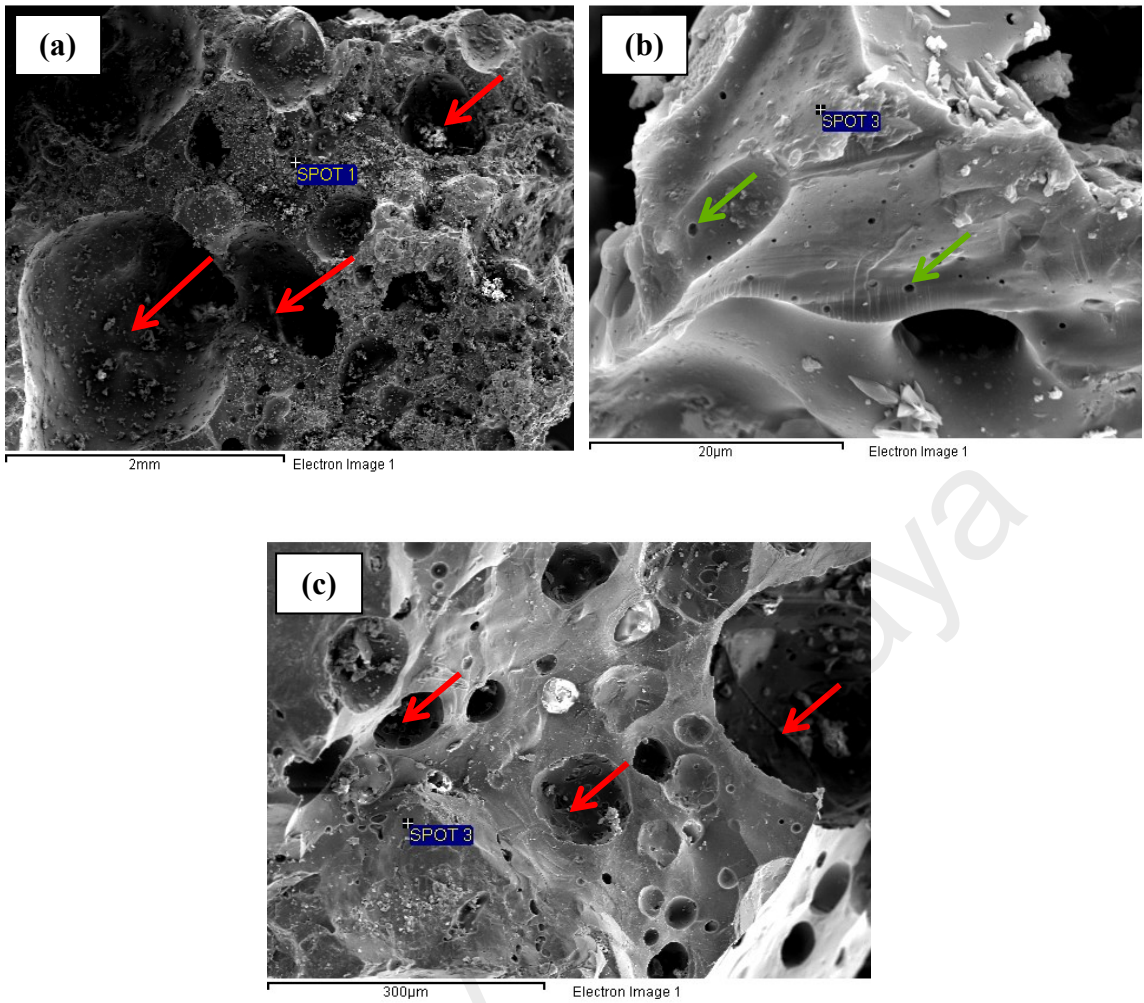

Figure 4.3: Porous structure on (a)(b) POC fine and (c) POC coarse ; red arrow indicates large porous and green arrows indicates micro voids

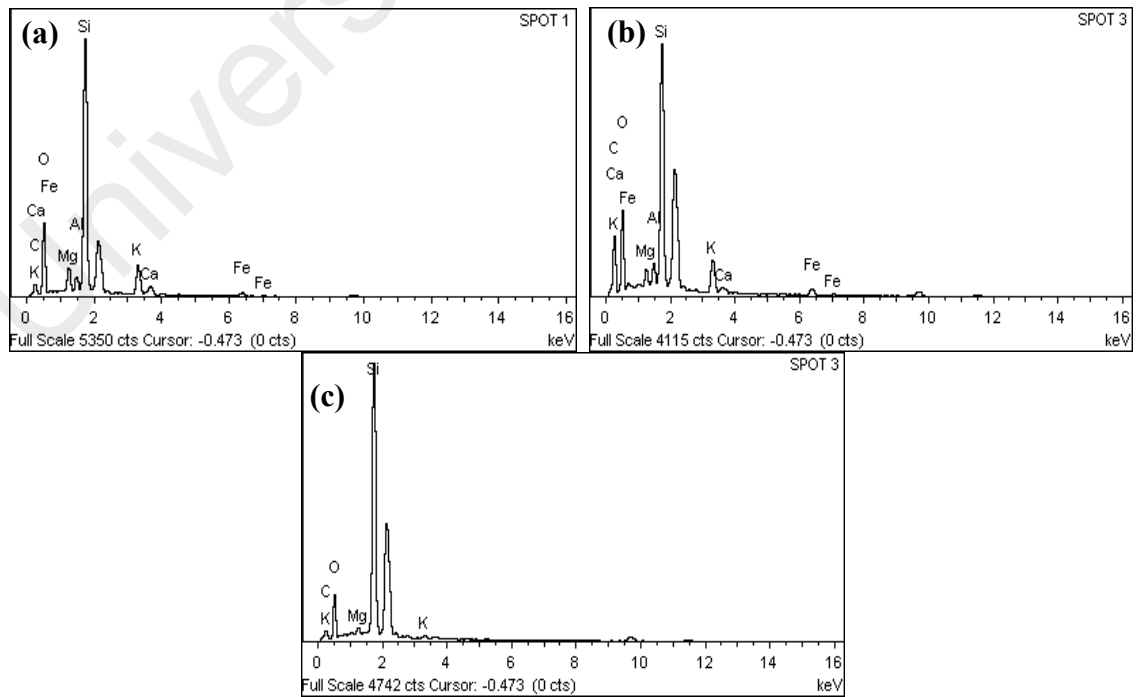

Figure 4.4: EDX on (a)(b) POC fine and (c) POC coarse

Figure 4.5 represents the POC powder morphology at 200× magnification. As observed from the morphology, POC powder can be categorized as generally angular and irregular. Irregularities can be seen clearly as some of them are flaky while some are with sharp edges. From Figure 4.8, as this POC powder does have some particles which are finer and coarser than cement at different intervals compared to cement, there is a huge possibility of creating micro voids or empty zones within the POC powder-cement interface. This would indeed create interstitial voids to reduce the particle packing of the mortar or concrete to certain extent to affect the hardened properties and durability characteristics. Figure 4.6 shows POC powder particle of irregular shape and structure with EDX results. The existence of smaller voids or perforated voids can be clearly seen. EDX plotted on the POC powder specimen also confirmed the XRF results on the major SiO₂ content. This result is parallel with the findings from the XRF chemical analysis. It is also evident that POC powder is generally irregular in shape whereby some flat surface layers can be also seen.

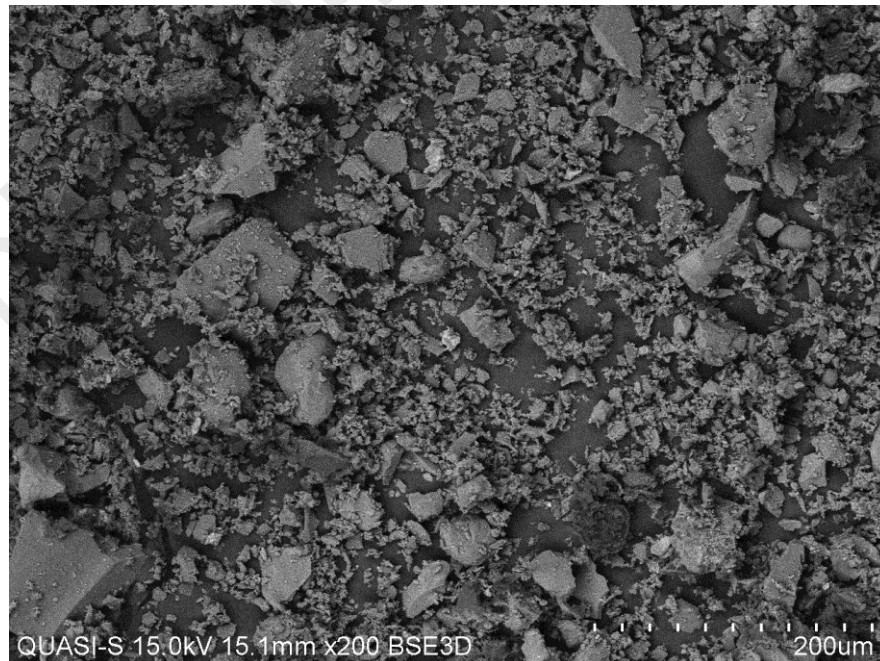

Figure 4.5: POC powder morphology obtained through SEM test

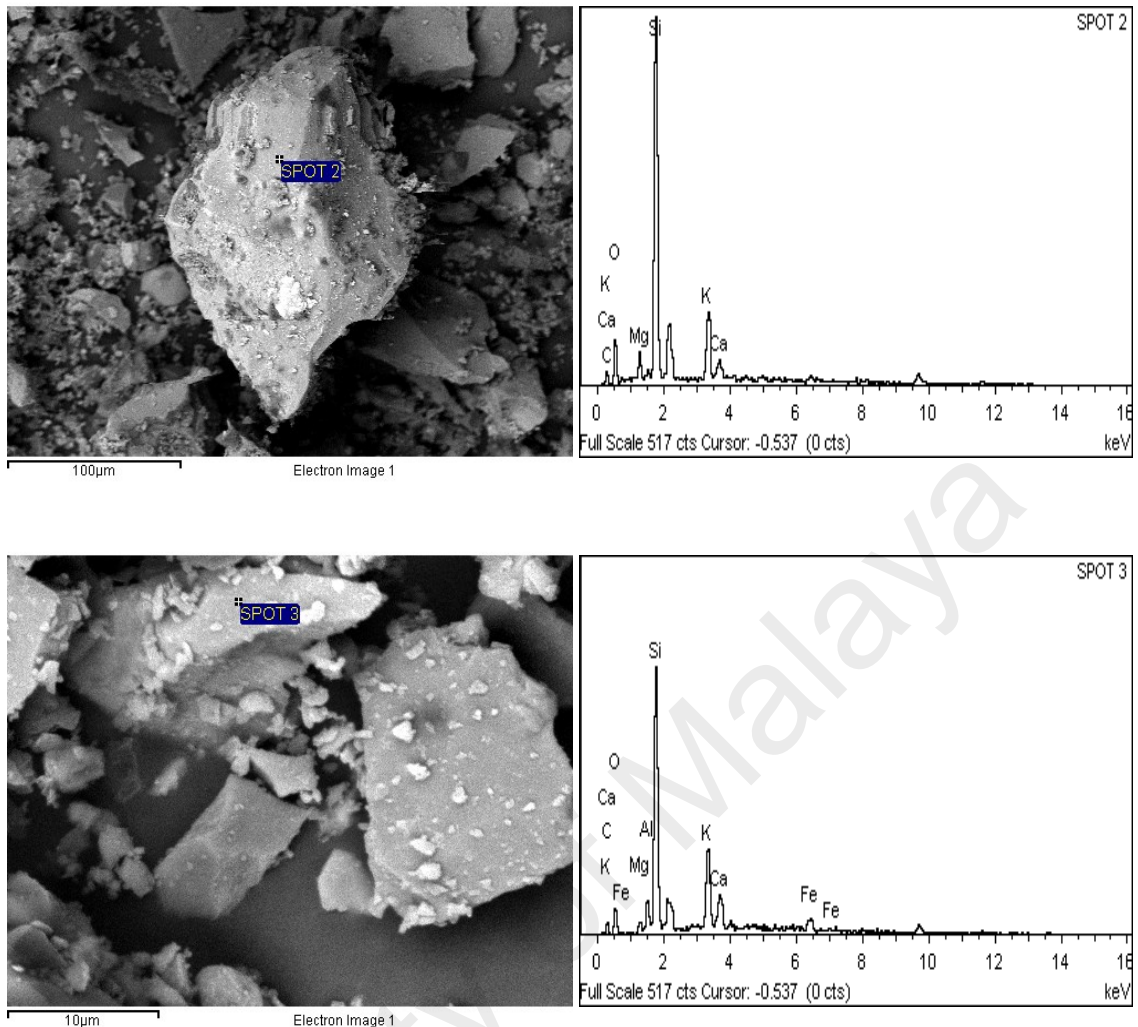

Figure 4.6: POC powder particle of irregular shapes and structures with EDX results

4.2.3 Particle Size Distribution

Grading of aggregates is one of the important factors that need to be considered in designing the self-compacting concrete (SCC) proportion as it affects the fresh properties substantially. Figure 4.7 shows the aggregate grading curves for POC fine and sand. As observed, POC fine and sand are within the limits stipulated by BS 882:1992 (1992). The similar grading curves between them indicate the similar distribution of fine particles between them which is expected to produce similar SCC and self-compacting mortar (SCM) properties. Moreover, the fineness modulus of POC fine and sand are 2.71 and 2.58 respectively. It is evident that the fineness modulus of these two aggregates is almost similar. Fineness modulus is one of important parameters that affects the SCC performance where it is helpful in containing the segregation in

addition to providing sufficient slump flow and viscosity properties (Khayat & Mitchell, 2009). Besides that, it is also expected to provide some effects to the strength propagation of the samples.

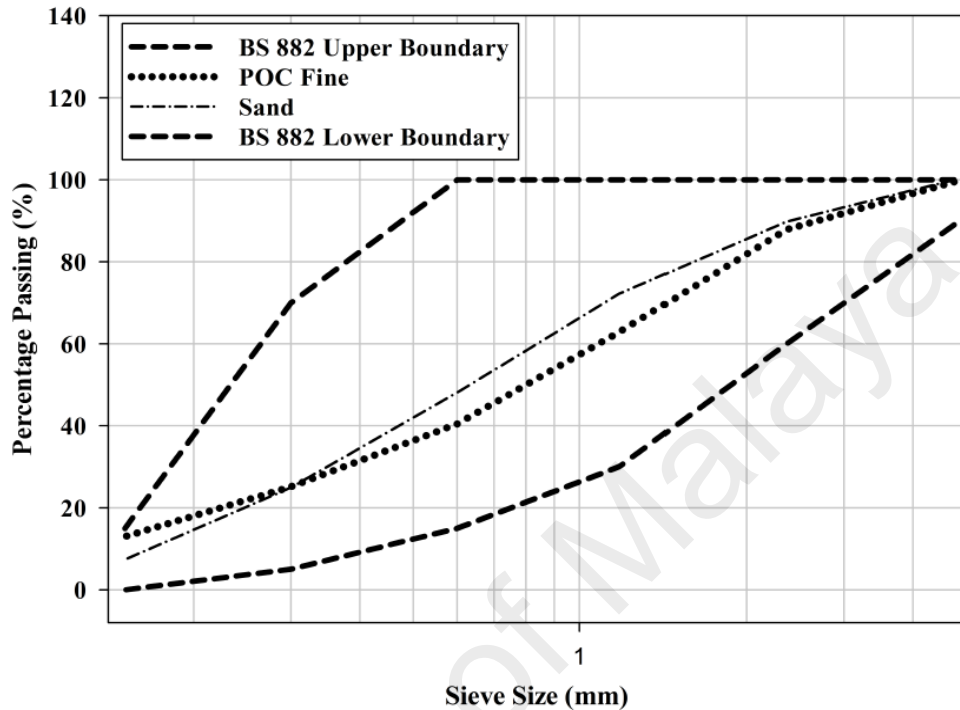

Figure 4.7: Fine aggregates grading curve

4.2.4 Aggregate Bulk Density

Bulk densities of aggregates are vital to check for the reduction in overall density of the concrete. The results obtained will be useful in understanding the possible difference in density of the concrete. Table 4.4 shows the bulk density of all the aggregates used in this study. As observed there is a significant reduction in the bulk density when POC coarse or POC fine were tested. On average, POC coarse is almost 44% lighter when compared to gravel. This may be due to the higher amount of voids on and within the aggregates which affects greatly towards the reduction in the density of the aggregates (as depicted in Figure 4.3). On the other hand, POC fine is about 38% lower in bulk density compared to sand. These two results are vital to help to bring down the density of concrete to achieve lightweight concrete range.

Table 4.4: Bulk density of aggregates used in this study

Material	Compacted SSD Bulk density (kg/m³)
Gravel (5-14mm)	1294.81
POC Coarse	731.49
Sand	1303.81
POC Fine	809.62
Gravel (5-10mm)	1438.62
Gravel (10-14mm)	1493.46
POC Coarse (5-10mm)	781.58
POC Coarse (10-14mm)	747.54

4.2.5 Aggregate Crushing Value (ACV)

The nature of POC which are porous may substantially affect the aggregate crushing value (ACV). Ten percent fines value (TFV) test was carried out according to BS 812 Part 111:1990 as the aggregate crushing value exceeded 30. Table 4.5 tabulates the ACV values for the coarse aggregates used in this study. Meanwhile, Table 4.6 depicts the TFV values of the coarse aggregates. It is evident that ordinary aggregates (gravel) are approximately three times resistant when subjected to crushing load compared to POC. Previous studies show that crushing strength of aggregates is affected by specific gravity, surface features, shape, water absorption, distribution and pore size (Fakhfakh et al., 2007; González-Corrochano et al., 2009; Hwang & Tran, 2015). The physical properties of POC which contains substantial amount of macro and micro voids affects the load bearing capacity of the POC aggregates when subjected to higher load. These voids allows for quick load propagation to make the POC aggregates weaker than the hardened concrete paste (as discussed in section 4.2.2). This is parallel with findings by

other researchers on POC (B. S. Mohammed et al., 2014). On the contrary, gravel which is of very smooth and solid surface requires a huge amount of force to create the separation between them. The lightweight properties of POC observed through lower specific gravity also greatly affects the strength of aggregates. The higher water absorption for POC as seen from Table 4.1 also confirms the presence of highly porous nature. The interstitial voids within the POC aggregates also confirm the possible greater water intake characteristics. Shape of the aggregates which are mostly irregular with sharp edges reduces load retention properties as the brittle nature of POC dominates and fails abruptly upon loading.

Table 4.5: Aggregate crushing values of coarse aggregates

Material	Aggregate Crushing Value (ACV)
Gravel	18.22
Gravel (5-10mm)	24.30
Gravel (10-14mm)	22.59
POC Coarse	56.40

Table 4.6: Ten Per Cent Fines Value of coarse aggregates

Material	Ten Per Cent Fines Value (TFV)
Gravel	-
POC Coarse	16.99
POC Coarse (5-10mm)	18.47
POC Coarse (10-14mm)	18.01

4.2.6 Aggregate Impact Value (AIV)

Aggregate impact value (AIV) values provide a measure of aggregate toughness. Table 4.7 shows the values obtained for ordinary aggregates and POC. Toughness properties are an important aspect that undermines possibly the failure rate of aggregate subjected to load. According to BS 882:1992 (1992), for non-wearing surfaces the AIV should be less than 45%. POC satisfied the range indicating the suitability of the material to be used as aggregates. Since the value is on the higher end of the limit, the aggregate should be considered less tougher compared to any other types of aggregates. This situation is due to the presence of internal voids in the form of honeycomb structure. Thin layers of POC coarse aggregate on the area surrounding the voids as depicted in Figure 4.3 (c) confirmed the reason behind this lower strength. It should be also noted that conventional aggregates (gravel) is about 6 times tougher compared to POC. The other two sizes of aggregates were tested according to the recommendation procedure outlined by BS 812-112 (1990). Both of these aggregates also satisfied well the range provided.

Table 4.7: Aggregate impact values of coarse aggregates

Aggregate Type	Aggregate Impact Value (AIV)
Gravel (10mm-14mm)	7.88
POC Coarse (10mm-14mm)	44.25
Gravel (5mm-10mm)	6.57
POC Coarse (5mm-10mm)	40.78
POC Coarse (5-14mm)	42.20
Gravel (5-14mm)	6.17

4.2.7 Characteristics of Cement and POC powder

Understanding POC powder characteristics are vital to assess the effect of using the powder in concrete. POC powder was prepared by grinding POC fine (<5mm) using a Los Angeles (LA) abrasion machine. Steel rods with similar diameters are used to crush and ground the POC fine in a Los Angeles abrasion machine. The running time is maintained constant for 24 hours before sieving POC powder under 300 μ m. Figure 4.8 shows the particle size distribution curve of POC powder. Particle size distribution curve of cement is also plotted together to understand the variation of sizes. It is evident from the plot that the fineness level of both cement and POC powder is almost similar. This is one of the most important aspects in evaluating the blending effects which could lead to some effects to the fresh, hardened and microstructural properties. Previous studies confirmed that fineness of powder or mineral admixtures is vital to alter the weakest part of the concrete which is the paste aggregate interfacial transition zone (ITZ) (Tasdemir et al., 1998; Tasdemir et al., 1999; Tasdemir, 2003). Meanwhile, Figure 4.9 shows the X-Ray diffraction pattern of POC powder. Significant silicon oxide (SiO₂) compounds are present within POC powder. Prominent peaks were observed for quartz and cristobalite components which is a sub-component or another form of silica. Sharp peaks were noted at 59.93° (Quartz), 50.11° (Quartz), 26.61° (cristobalite) and 20.83° (quartz). Figure 4.10 depicts the comparison of quantitative XRD results between POC powder, silica fume and fly ash. As observed, the amorphous quantity of materials is 39.9%, 37.6% and 37.5% respectively for POC powder, silica fume and fly ash, respectively which are almost similar.

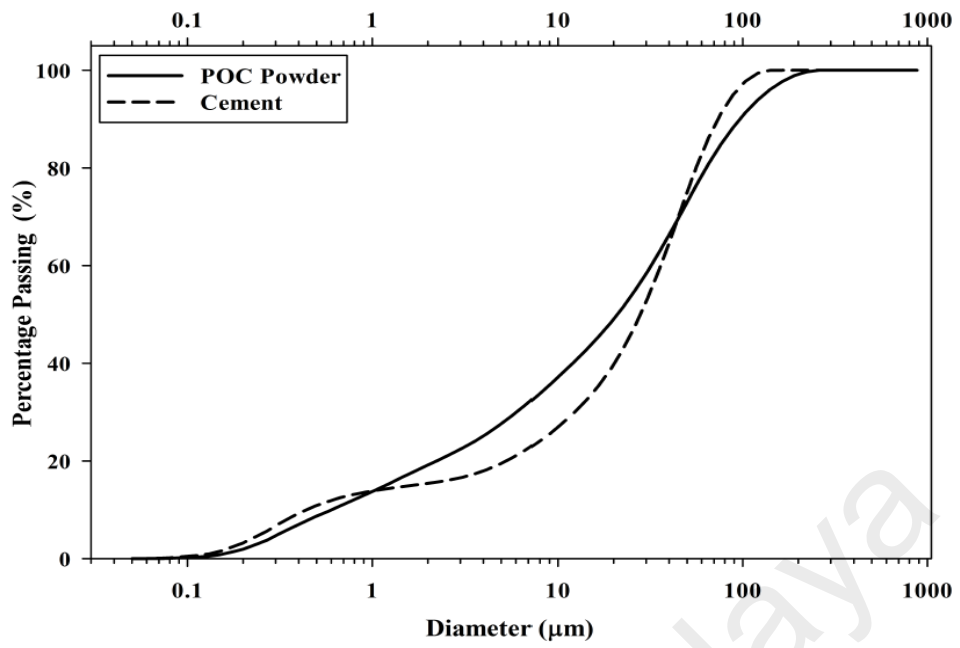

Figure 4.8: Particle size analysis for POC powder and cement

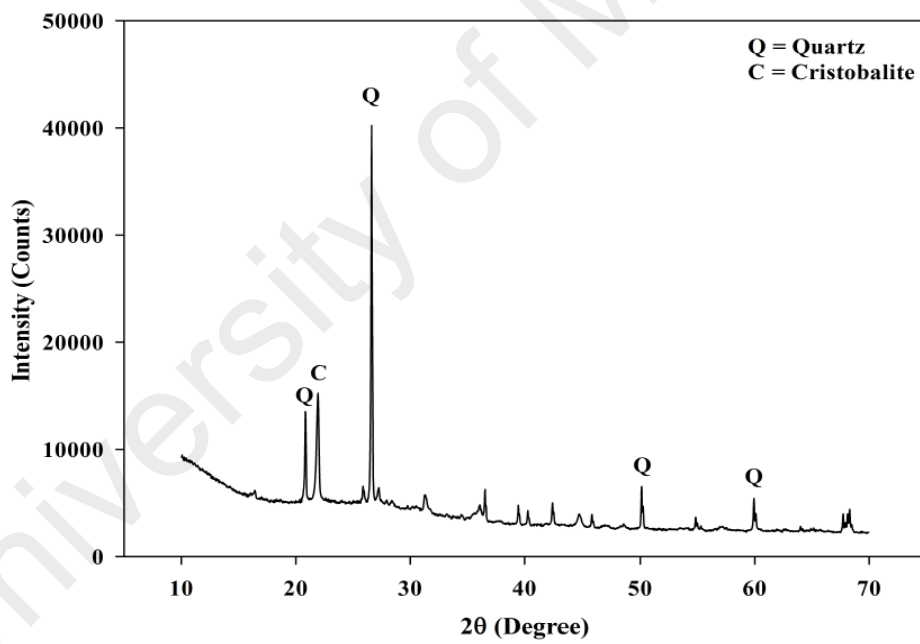

Figure 4.9: X-Ray diffraction (XRD) of POC powder

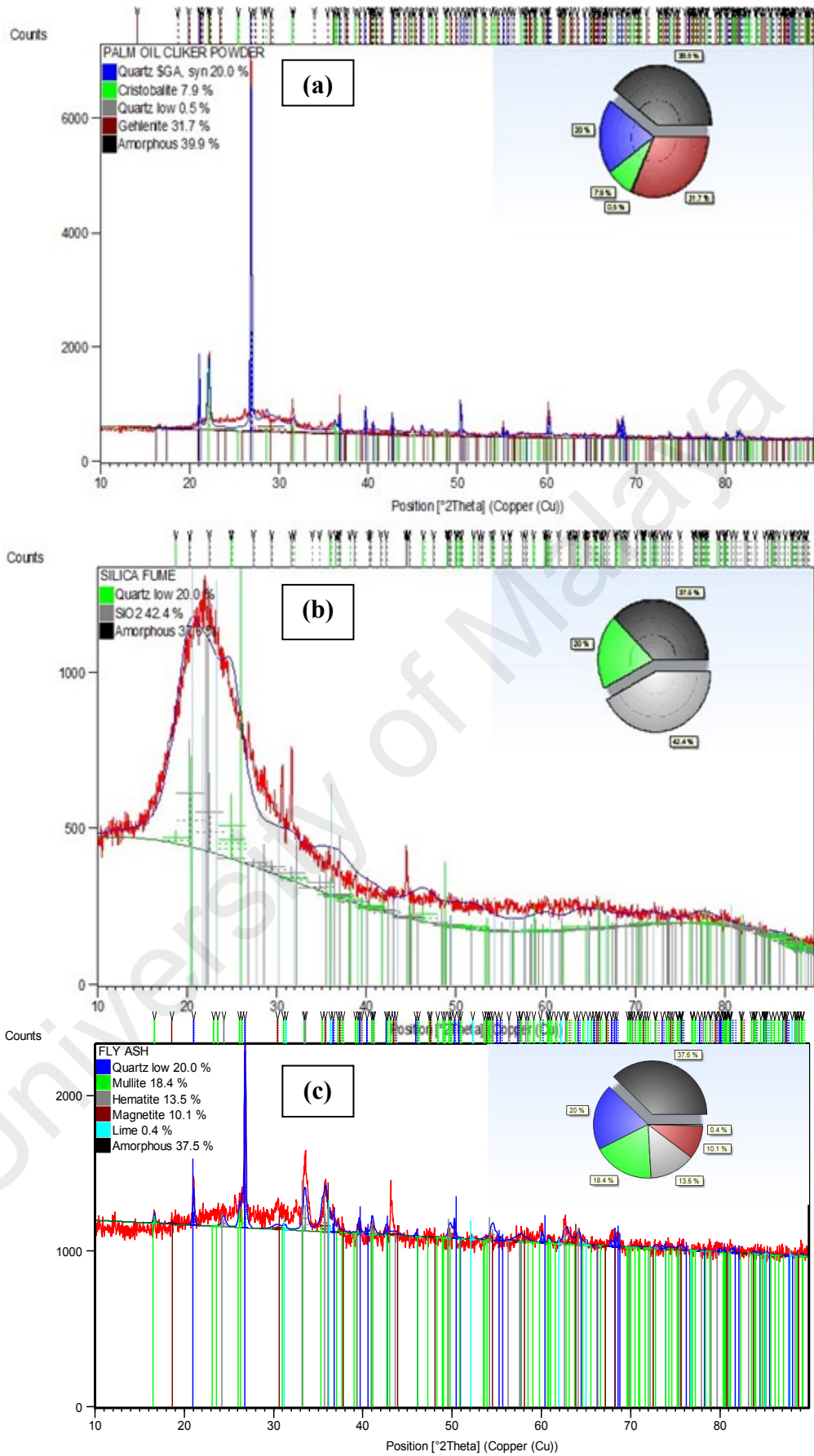

Figure 4.10: Comparison of QXRD between (a) POC, (b) silica fume and (c) fly ash

Table 4.8 tabulates the chemical and physical characteristics of cement and POC powder. Differences can be clearly observed between the values of SiO_2 and some other major oxides. SiO_2 which is generally on the higher side may help to increase the strength ratio due to its higher silica content. Cement used in this study satisfied well the minimum requirements of ASTM C150 (2012) and Neville (1973). Powder materials consumed in POC SCC were analyzed chemically to understand the major elements available within the material. This is vital to understand the reaction and behavior of material when utilised with other materials. The expansion due to MgO is a vital property to assess to avoid failures within the concrete. Table 4.9 shows the guidelines for autoclave expansion due to MgO. The ratio between $\text{MgO}:\text{Fe}_2\text{O}_3$ gives an indication on the possible autoclave expansion in concrete (Klemm, 2005). In this study, the ratio of $\text{MgO}:\text{Fe}_2\text{O}_3$ was 1.06 which satisfies the <1.20 limit. This shows that the cement is still within the acceptable range. As POC powder is also used in this study to supplement the need for extra powder, an analysis was also carried out on MgO expansion. The XRF analysis shows that POC powder has a ratio of 0.48, which is well within the acceptable range to avoid expansion due to MgO. This study was important to ensure the effectiveness of using this by-product in concrete as an additional powder material. On top of that, as POC powder is used to supplement cement, it is important to evaluate it against Class N of ASTM C618 (2015) for local class of natural pozzolans. ASTM C 311 provides further information on the sampling technique required to test the pozzolanic activity of the powder samples. Table 4.10 shows the comparison of POC powder to a standard. POC powder also conforms to the pozzolanicity requirement as indicated by ASTM C618 (2015).

Table 4.8: Chemical and physical properties of binders

Chemical Properties				
Oxides	Cement (%)	Cement Limits (%) (ASTM C150 (2012))	Cement Limits (%) (Neville, 1973)	POC Powder (%)
CaO	64.00	-	60 - 67	6.37
SiO ₂	20.29	-	17 - 25	59.90
SO ₃	2.61	3.50 (Max)	2.0 – 3.5	0.39
Fe ₂ O ₃	2.94	-	0.5 – 6.0	6.93
Al ₂ O ₃	5.37	-	3 - 8	3.89
MgO	3.13	6.00 (Max)	0.5 – 4.0	3.30
P ₂ O ₅	0.07	-	-	3.47
K ₂ O	0.17	-	-	15.10
TiO ₂	0.12	-	-	0.29
Mn ₂ O ₃	0.12	-	-	-
Na ₂ O	0.24	-	0.3 – 1.2	-
Others	0.94	-	-	0.36
Loss on ignition	1.40	3.00 (Max)	-	1.89
MgO : Fe ₂ O ₃	1.06	-	-	0.48
Bogue compound composition of cement	% by mass			
C ₃ S	58.62			
C ₂ S	13.95			
C ₃ A	9.26			
C ₄ AF	8.95			
Physical Properties				
Specific gravity	3.15	-		2.59
Surface Area (m ² /kg)	309.68			346.46

Table 4.9: Guidelines for autoclave expansion due to MgO in cement

MgO:Fe₂O₃	Effect
>1.53	Plant in trouble: autoclave expansion prevalent
>1.40	Danger zone; high probability of expansion; any appreciable free CaO gives excess expansion
<1.40	Probability of expansion failure decreases rapidly
<1.20	Standard control target (maximum value) – failure due to MgO very unlikely

Table 4.10: ASTM C618 (2015) Class N requirements

Component	POC Powder (%)	ASTM Class N Requirement (%)
Silicon Oxide (SiO ₂) + Aluminium Oxide (Al ₂ O ₃) + Iron Oxide (Fe ₂ O ₃)	70.72	70.0 (Minimum)
Sulfur Trioxide (SO ₃)	0.39	4.0 (Maximum)
Available Alkalies (Na ₂ O)	-	1.5 (Maximum)
Loss on ignition	1.89	10.0 (Maximum)

4.3 Classification of Local POC throughout Malaysia

This study was carried out to ascertain the quality or feasibility of POC available throughout each state in Malaysia. As it is a locally available material, a study on its feasibility will be helpful to further utilise it in the construction industry. Furthermore, this study being the ‘first of its kind’ to investigate the overall POC properties throughout Malaysia would impart an importance to the palm oil mill managements and business sectors to capitalize on the potential of the material. Through this study,

substantial information on the chemical and physical variation between each state can be gathered to classify and understand their ability. POC samples were collected from every state in Malaysia to check and analyse their characteristics. As of July 2014, there are almost 440 fresh fruit bunch (FFB) palm oil mills operating in Malaysia. 247 of them are located in Peninsular Malaysia, while others are in Sabah and Sarawak respectively (MPOB, 2014). One mill per state was selected randomly without taking into consideration any location and management factor. Although there are 14 states in Malaysia, samples were collected from 12 states excluding Perlis and Wilayah Persekutuan Kuala Lumpur (K.L) due to unavailability of palm oil mills. The POC collected from each mill would represent the fruit bunches received from the plantation areas which are within 100km of radius from the mill. Figure 4.11 shows the location of palm oil mills where the POC samples was obtained. This study was conducted parallel with laboratory works as all the samples were cast and tested for its hardened properties.

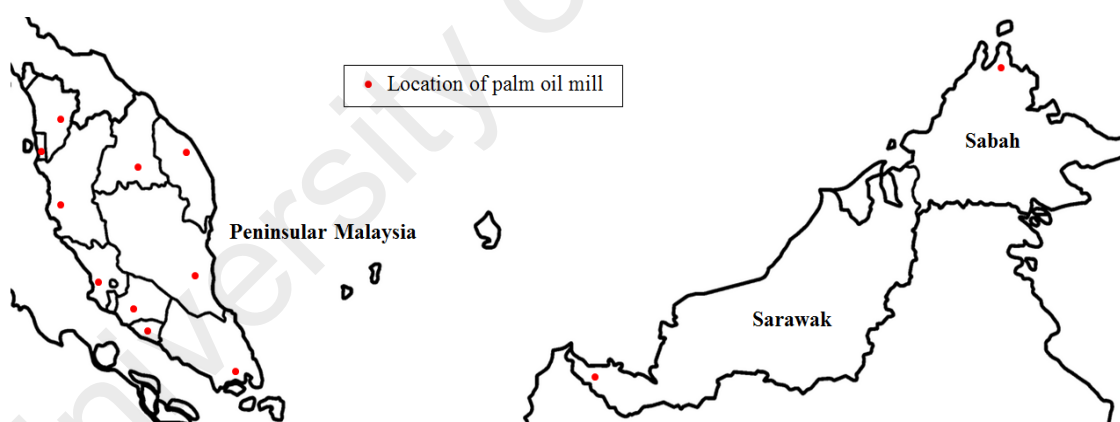

Figure 4.11: Location of palm oil mills selected for POC sampling in Malaysia (Map from www.Mapsof.net)

4.3.1 Physical and Chemical Properties of POC throughout Malaysia

The main objective of this exercise is to identify the variation of physical and chemical properties of POC samples from various locations in Malaysia. The state abbreviation and their respective physical properties are tabulated in Table 4.11. Chemical constituents of POC from each state were evaluated through X-ray

fluorescence (XRF) test and are presented in Table 4.12. As observed, the SiO₂ content showed small standard deviation value of 5.13% indicating small variation in terms of the factors discussed earlier. As SiO₂ is one of the important factors giving difference towards the engineering properties of the mortar and strength properties, a study is required to address this factor. Although the deviation is quite large compared to different states, generally they can be grouped to be within a range of between 60% and 75%. Figure 4.12 shows the ACV of the state POC samples obtained from different locations. It is one of the most important components as it could provide an indirect measurement for engineering properties prediction. The test was performed as stipulated by BS 812-110 (1990) and BS 812-111 (1990). A brief analysis showed that sample from Perak which had the highest SiO₂ content gave the highest ACV values indicating a possible correlation between them. However, a direct relationship cannot be obtained among them as further studies are required. As the silica content level is also a measurement of the strength of the material, higher SiO₂ value provided a higher strength property.

In order to further characterise POC, a mineralogical analysis on all the samples was performed using X-ray diffraction (XRD). XRD analysis was performed using a PANalytical Empyrean diffractometer which has a Cu K α of 45kV and 30mA. The specimens were ground to fine powder of size less than 45 μ m for this test. Figure 4.13 depicts the overall plot of XRD plot for each state. It is evident that all the samples showed similar peaks of predominantly quartz at 2 θ values of 20.83°, 26.61°, 50.11° and 59.93°. Besides that, cristoballite crystallised phases were also detected majorly at 21.92° peak. This pattern of peaks was also noted from previous study for different powder materials such as fly ash and RHA (Sua-iam & Makul, 2014). From an overall observation, it is clear that the results are very much consistent indicating the feasibility of utilising POC in concrete. As POC powder is also used to supplement the need for

extra paste volume, the amorphous state of the powder was assessed using QXRD with Rietveld analysis. This is one of the powerful analysis tools available to quantify the crystalline phases available within the powder samples compared to readily available analytical method. It will be discussed in POC powder section 5.3.

Table 4.11: Physical characteristics of POC from various sources

State	State Abbreviation	Specific Gravity	Water Absorption (%)	Moisture Content (%)
Kedah	KDH	2.23	1.93	0.17
Kelantan	KLT	1.81	4.12	0.25
Terengganu	TRG	2.07	2.28	0.04
Pulau Pinang	PNG	2.13	3.05	0.07
Perak	PRK	2.11	1.40	0.04
Pahang	PHG	2.29	2.34	0.03
Negeri Sembilan	NSE	2.33	4.05	0.31
Selangor	SEL	2.11	4.10	0.48
Melaka	MLK	2.28	1.65	0.02
Johor	JHR	2.21	2.37	0.17
Sabah	SBH	2.08	2.54	0.05
Sarawak	SWK	2.16	5.67	0.04
Selangor	NML*	2.60	1.59	0.07

*NML – River sand obtained from a source in state of Selangor

Table 4.12: Chemical composition of the POC samples from different states

State	SiO ₂	K ₂ O	CaO	SO ₃	Fe ₂ O ₃	Al ₂ O ₃	MgO	P ₂ O ₅	TiO ₂	Na ₂ O
KDH	65.10	9.23	3.89	0.16	6.34	3.28	2.34	3.06	0.13	0.07
KLT	73.31	8.78	4.01	0.13	6.13	6.00	2.83	1.43	0.28	0.09
TRG	72.64	9.65	4.42	0.17	3.89	5.18	2.56	3.96	0.17	0.01
PNG	69.91	9.24	8.56	0.14	5.15	4.15	3.92	3.24	0.15	0.12
PRK	74.29	6.22	5.10	0.15	2.09	3.11	1.72	2.79	0.15	<0.1
PHG	60.79	5.17	10.88	0.18	15.64	7.27	2.23	1.61	0.27	0.13
NSE	65.64	7.26	4.11	0.25	14.41	7.56	2.64	1.73	0.29	0.08
SEL	64.84	12.82	5.96	0.16	4.19	3.42	5.01	3.37	0.12	0.09
MLK	57.41	11.32	6.95	0.22	10.11	4.95	4.01	4.90	0.17	0.12
JHR	69.05	11.09	5.70	0.19	3.71	4.73	2.27	3.22	0.23	<0.1
SBH	62.45	13.48	9.51	0.21	2.20	1.42	6.09	7.33	0.07	0.05
SWK	62.52	8.44	16.74	0.23	1.10	0.82	3.43	4.75	0.08	0.11
Standard Deviation	5.13	2.40	3.63	0.04	4.54	1.99	1.24	1.59	0.07	0.03

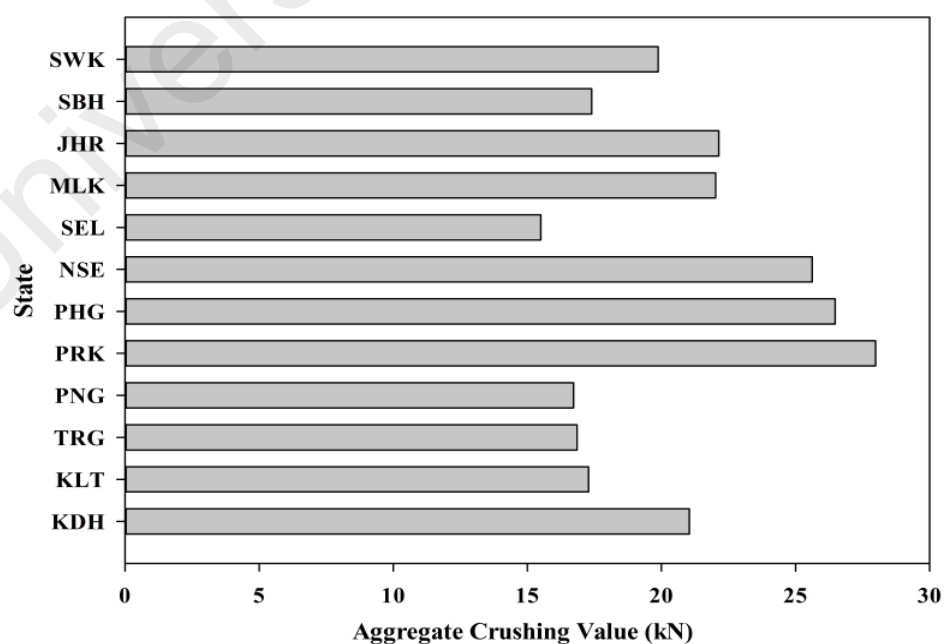

Figure 4.12: Aggregate crushing values (ACV) for various states

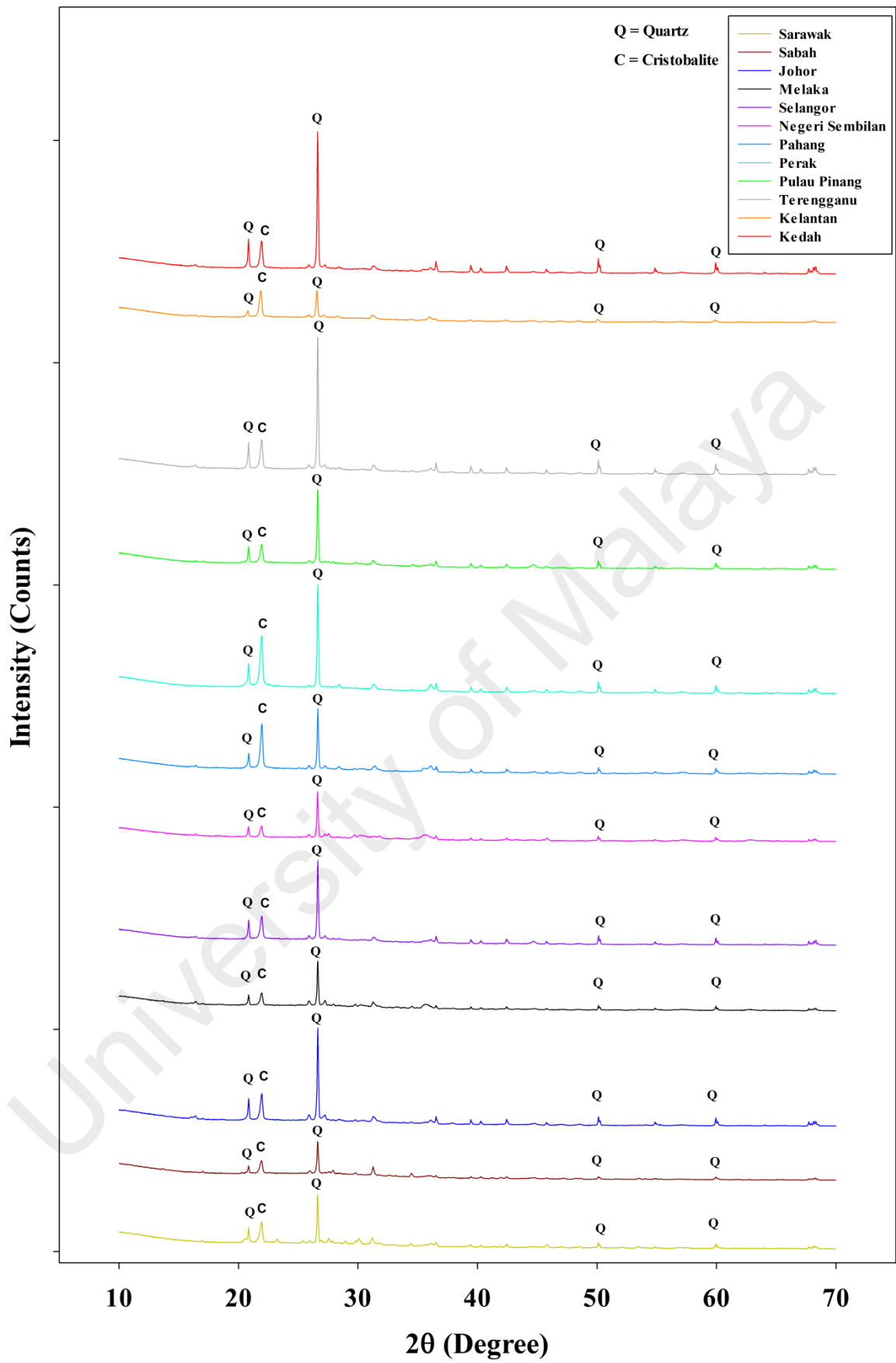

Figure 4.13: X-Ray diffraction results for all states

4.3.2 Heavy Metal Analysis for Selected POC State Samples

The leachate analysis is one of the vital parts of the study as it determines the possible effects of using these aggregates and powder material in concrete or mortar. As the material itself plays a vital role in exhibiting the hazardous properties to the surrounding, there is an important need to understand the concentration of the metal components that are present within the material. As discussed earlier, palm oil mills dispose POC in their plantation areas as covers for potholes or natural road curbs. This would lead to possible soil pollution if substantial metal components are present. As this study examines for the first time the use of POC in concrete, a complete assessment is required to highlight the metal constituents within POC to confirm the actual scenario in case there is hazardous materials presence. A heavy metal analysis was carried out using inductively coupled plasma (ICP) to check if the discharge of POC conforms to the regulation of soil discharge and water pollution. Few states were selected randomly considering their locations in the north (Terengganu), West (Perak), South (Johor) and East (Sarawak). It is important to analyse the data as it plays an important role to urge the palm oil mill owners to cut down on landfilling but alternatively divert them into another use. A direct measurement of the metal concentration allows for determination of the rate of leachate properties. The results obtained were compared with three different local regulations from Malaysia and Singapore. Table 4.13 shows the heavy metal concentration and their comparison to the regulated limits. As observed all the values are within the stipulated limits. It should be noted that use of POC in an alkaline cementitious mix will bind the heavy metal to provided non leaching properties. However, presence of certain traces such as chromium, magnesium and aluminium affect greatly the soil structure to cause serious harms to the plants such as reduced shoot and root growth, lower seed germination and inability of plant nutrient acquisition (Chibuike & Obiora, 2014). Drinking water quality standard was also provided to show

the variation in different types of standards as there is a possibility of POC leachates reaching the water table when improper land fillings are carried out.

Table 4.13: Heavy metal analysis comparison with standards

Analyte	Sarawak	Terengganu	Perak	Johor	Limits	Limits	Limits
					SDS*	MSoil*	DWQS*
Ag	0.00	0.00	0.00	0.00	-	-	0.05
Al	7.48	19.68	4.22	8.33	-	-	0.20
Ca	0.17	0.10	0.19	0.16	-	-	-
Cd	0.23	0.13	0.07	0.08	-	-	0.03
Co	0.04	0.05	0.07	0.04	-	-	1.0
Cr	0.19	0.56	1.50	0.16	5	-	0.05
Cu	0.53	0.39	0.78	0.52	100	13.8	1.0
Fe	9.31	53.74	72.49	2.58	100	12140	0.3
K	0.06	0.15	0.04	0.12	-	-	-
Mg	29.74	49.50	38.81	76.79	-	141.4	150
Mn	0.96	2.74	2.18	2.19	50	3.97	0.1
Na	0.00	0.01	0.00	0.01	-	-	200
Ni	0.08	0.16	0.29	0.11	5	-	-
Pb	0.15	0.14	0.11	0.10	-	10.37	0.01
Zn	0.13	0.16	0.09	0.22	100	21.9	3

*SG – Singapore Discharge Standard

*MSoil- Malaysian Soil Standard

*DWQS- Malaysian Drinking Water Quality Standard

4.3.3 Contributory Factors towards Variation in the POC Sample Constituent

There are a number of variations observed from the detailed analysis of these samples collected from various locations. Although the soil variation remains qualitative, this study provides some indications on the possible ways to standardize the POC obtained from various mills in Malaysia. One of the major variations will be probably due to the difference in burning temperature of the boiler. Based on the discussion and visit to almost 20 palm oil mills in Malaysia including Sabah and Sarawak, the temperature of the boiler for daily processing are kept on average between 600°C to 850°C. Figure 4.14 shows a schematic diagram of a typical power house in a palm oil mill. The temperature plays a vital role since it affects the complete combustion or burning process of oil palm shell (OPS) and oil palm fiber (OPF) to produce POC. The pyrolysis process which takes place during this high temperature (700°C) burning affects the formation of crystalline structure within OPS and OPF to produce some difference in the formation of honeycombed structure POC generally. Researchers report that a palm oil mill that was chosen for their study had a boiler temperature of 700°C, pressure 300psi and solid fuel (fiber and shell) intake rate of about 6000kg/hr (Rashid et al., 2013). It was observed at the end of burning process that there was substantial amount of macro voids and micro voids within the POC aggregates. There is a high possibility that at lower burning temperature, the formation of POC may not be that complete which in a way will affect the concrete properties (Guo & Lua, 2001).

In addition to that, the proportion of OPS and OPF used as feed in boilers also influences the burning temperature and formation of proper POC. As the physical and chemical properties of OPS and OPF vary greatly, the burning intensity may be different. Palm oil mill management does decide on the proportion to suit their economic and waste disposal system need. Vijaya et al. (2008) reported that palm oil

mills vary their boiler feed intake depending on their need of utilisation. Based on the economic and environmental point of view, the mill management varies its daily operation to accommodate the customer's request. Some mills sell their palm oil shells and fibers at certain proportion to meet other needs in another industry. 68% of the palm oil millers in a survey carried out preferred to sell their additional biomass waste to outsiders (Umar et al., 2014). This alters the proportion of boiler feed to generate fuel for burning. Harimi et al. (2008) carried out study on seven mills in Perak and found that all the mills opt for different proportion of oil palm shell to fiber ratio resulting in varying calorific values. Some mills do burn POC at OPS:OPF at 50:50, 60:40, 70:30 proportion in their boilers. Nowadays, OPS are used as a fuel in European and Asian countries as it contains high calorific value. Moreover, OPF are also being used as a replacement for wool or sponge and as fillers in energy absorbing applications. For an example, they are utilised as fillers in car seat, mattresses and insulators (Basiron & Simeh, 2005). Based on these applications, palm oil mill tends to vary their proportion of OPS and OPF according to their company's economic view.

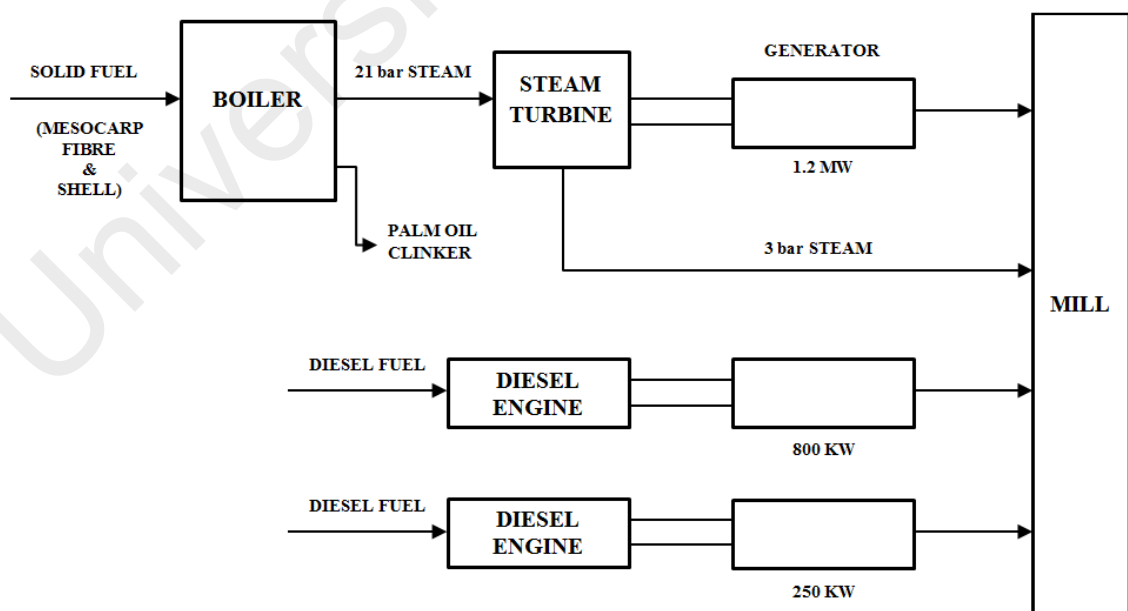

Figure 4.14: Schematic diagram of a typical power house in palm oil mill (Adapted from Yusoff (2006)).

In addition to that, the types of soil also play a vital role in affecting the properties and type of OPS and OPF produced. The nutrients absorbed by the tree during the production of these plant components will vary according to the available chemical nutrients in soil. The soil properties variation studies were carried out by determining the location of the palm oil mill sample collection with respect to their GPS coordinates. It would be a great finding that can help to control and optimize the quality of POC which will eventually enhance the hardened properties of concrete. In Malaysia, there is a classification system of soil which was carried out to differentiate the various types of soil. The soil classification was carried out according to Paramanathan (2000). Each palm oil mill location was overlaid on a soil map to distinguish the type of soil available on the surrounding area of the palm oil mill. Based on the GPS coordinates of each respective palm oil mills, the location was mapped on the soil map using MapInfo Software. The studies were carried out at Sime Darby Research Centre, Carey Island. Figure 4.15 and Figure 4.16 shows the overlay of GPS location on a soil map for soil classification studies for state of Selangor and Kelantan, respectively. Table 4.14 tabulates the overall soil classification for each state in Malaysia taking into consideration the majority of soil constituent that are present. There are almost 30 types of soil types depending on the geographical location of the plantation areas. They are named locally to ease the verification process. However, the soil type outlined was for the soil located within 100km of radius from the palm oil mill which was selected in each state. Hence, in future greater amount of samples can be collected from different oil palms in a state to get a much representative soil type of the particular state. Generally in Malaysia, the types of soil can be divided into coastal areas and highland areas. The coastal areas would majorly consist of sand such as silty sand, clayey sand. While the highland areas would be mostly of clay and conventional soil. Thus it can be

deduced that there are three major properties that affects the quality of POC produced in the factory. They are,

- Burning temperaute and pressure
- Proportion of OPF and OPS
- Soil type

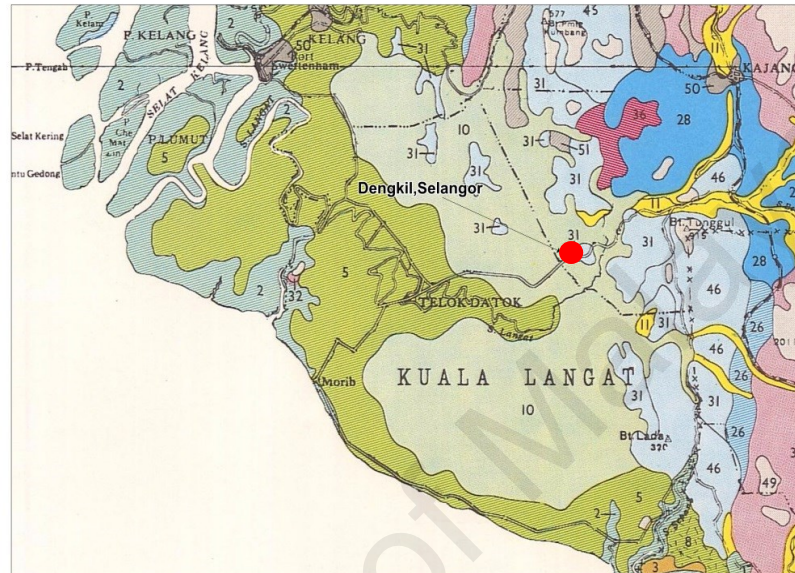

Figure 4.15: Overlaid oil palm mill location with soil map (Selangor) (Red dot indicates the GPS location of Selangor palm oil mill)

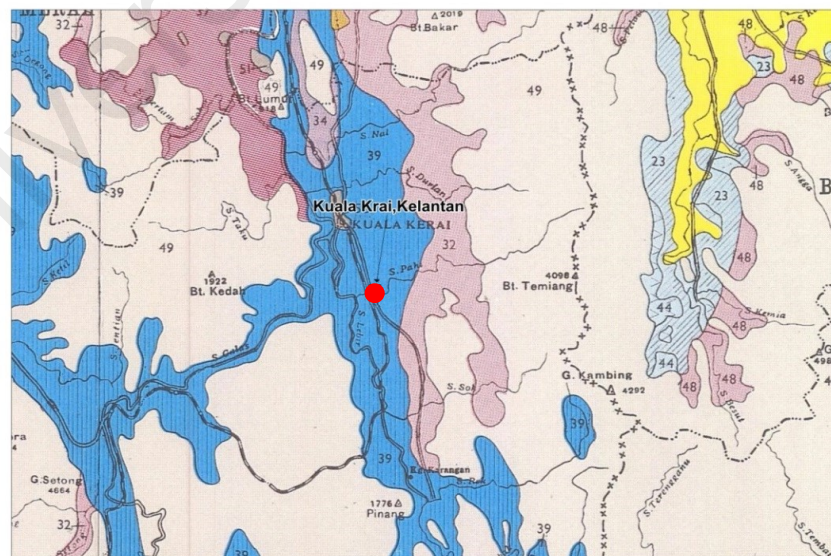

Figure 4.16: Overlaid oil palm mill location with soil map (Kelantan) (Red dot indicates the GPS location of Kelantan palm oil mill)

Table 4.14: Soil types of each state in Malaysia

State	Soil Type	Soil Classification
KDH	Gajah Mati	Clayey-Skeletal (>35% gravel within 50cm depth, >35% Clay)
KLT	Musang	Fine silty (35% - 60% Clay, >30% silt)
TRG	Kuala Brang	Fine clayey (35% - 60% Clay, <30% silt). Moderately deep (50-100 cm) soil
PNG	Briah	Clayey (>35% Clay)
PRK	Sogomana	Very fine (>60% Clay)
PHG	Rengam	Fine clayey (35-60% clay; <30% silt)
NSE	Batu Anam	Fine silty (35% - 60% Clay, >30% silt)
SEL	Bungor	Fine clayey (35% - 60% Clay, <30% silt)
MLK	Tai Tak	Fine clayey (35-60% clay; <30% silt)
JHR	Serdang	Fine loamy (18%-35% Clay)
SBH	Paliu	Fine sandy clay (35% - 60% Clay; <30% silt)
SWK	Bekenu	Fine loamy (18%-35% Clay)

CHAPTER 5: MECHANICAL, ENGINEERING AND DURABILITY

PROPERTIES

5.1 Introduction

The mechanical, engineering and durability properties of palm oil clinker (POC) powder mortar, POC fine mortar and self-compacting POC concrete specimens were evaluated. A pilot study was carried out on only POC powder and POC fine to investigate the enhancement and positive contribution of these materials in self-compacting mortar (SCM). The purpose of this study is to understand the effect of these materials separately and correlate their enhancements when they are incorporated in concrete. Fresh properties of self-compacting concrete (SCC) was discussed pertaining to the different POC replacement ratio and elevated POC powder usage. Tests carried out comprise of slump flow, V-funnel, L-box, T_{500} and segregation resistance evaluation. Moreover, a rheological study was carried out on SCC and SCM to establish a relationship between the POC component addition and fresh properties. These relationships were then correlated with available standard models provided by previous studies. The rheological study was vital to further establish quantified relationships between different proportions of POC materials. Hardened properties of SCM and SCC were evaluated to understand further the effect of using POC in concrete. The hardened properties tests include ultrasonic pulse velocity (UPV), density, compressive strength, flexural strength, indirect splitting tensile strength and modulus of elasticity. Besides hardened properties, durability studies were also conducted on selected mixes to check the long term behaviour of the concrete in structural elements. These tests comprises of water absorption, sorptivity, rapid chloride penetration test (RCPT) test and sulfate resistance test. Lastly, two prototypes incorporating high volume of POC were developed adhering to the concept of ‘research leading towards an invention’.

5.2 Assessment of Local Palm Oil Clinker (POC) Aggregates

A study was carried out to evaluate the performance of POC collected from every state in Malaysia in SCM. Their physical, chemical and microstructural characteristics were evaluated thoroughly before being incorporated into mortar mix to determine the effects of POC utilisation. The rationale behind this study is to understand the possible effects from different physical and chemical properties of POC obtained from various sources.

5.2.1 Fresh Properties

As a better medium of comparing the real performance of POC aggregates for construction purposes, POC fine from all the states were integrated into SCM. Similar to SCC, SCM also provides an enhanced performance in giving good flowability, segregation resistance and passing ability. Tests carried out include slump flow and V-funnel test. Taking into consideration the POC aggregates condition (porous and irregular), the particle packing (PP) would be seriously affected. This necessitates the need of coating the aggregates to enhance the fresh properties. With a layer of coating provided, the POC aggregates will have a better rolling capability which increases the flowability of the concrete or mortar. Table 5.1 tabulates the mix proportion for the feasibility study. Figure 5.1 shows the slump flow range for the POC samples from each state in Malaysia. The slump flow range was kept between 250mm and 300mm (as indicated by the horizontal dashed line) as it provides better deformation characteristics. This particular range was also suggested by other researchers for SCM (Domone & Jin, 1999; Benabed et al., 2012). As observed, all the slump flow values fell within the range. Figure 5.2 shows the V-funnel test time for all the state samples. This test provides an indication on the viscosity of the mixes. In this study, the fineness modulus of all state samples was maintained the same to achieve a similar workability range. Viscosity changes in the mixes are related back to the different water absorption and

physical characteristics of the aggregates from every state. The V-funnel range in this study can be classified as between 10s and 30s.

Table 5.1 : Mix proportion for feasibility study

State	Cement (kg/L)	Water (kg/L)	POC Fine (kg/L)	S.P Dosage (%)
KDH	0.91	0.26	1.00	0.6
KLT	0.91	0.26	0.81	0.5
TRG	0.91	0.26	0.93	0.5
PNG	0.91	0.26	0.96	0.5
PRK	0.91	0.26	0.95	0.6
PHG	0.91	0.26	1.03	0.6
NSN	0.91	0.26	1.05	0.5
SEL	0.91	0.26	0.95	0.4
MLK	0.91	0.26	1.03	0.5
JHR	0.91	0.26	0.99	0.4
SBH	0.91	0.26	0.94	0.5
SWK	0.91	0.26	0.97	0.4

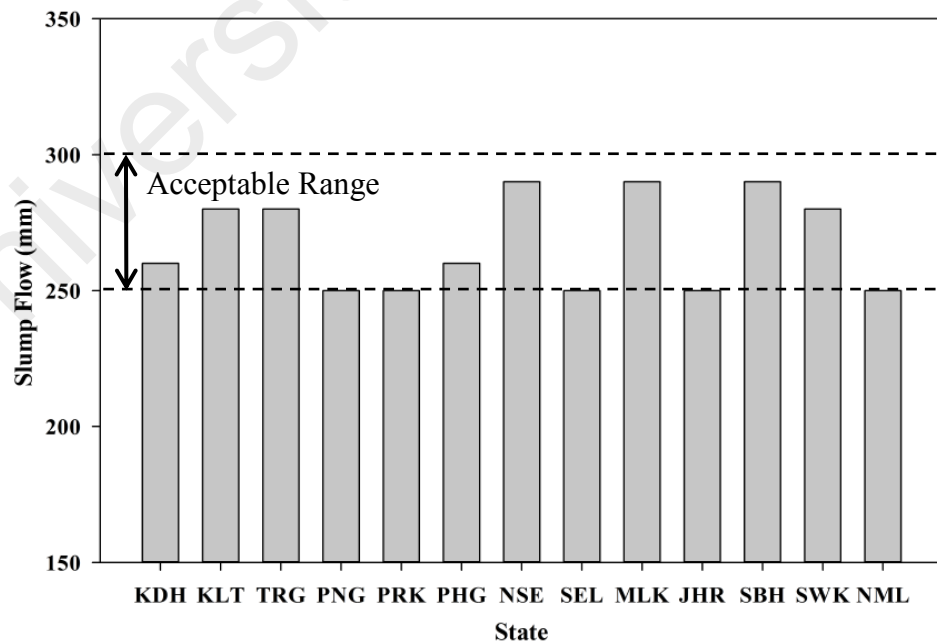

Figure 5.1: Slump flow values for POC samples from each state in Malaysia

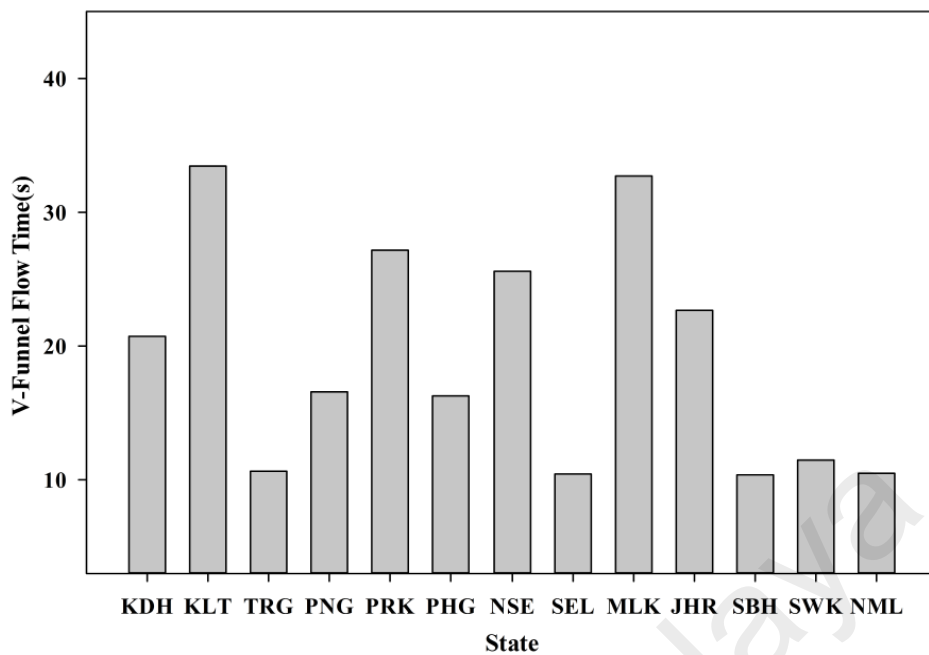

Figure 5.2: V-Funnel test results for POC samples from each state in Malaysia

5.2.2 Density

Figure 5.3 shows the density of mortars prepared from various state samples. The substitution of sand with sand reduced the density of the mixes as the density of POC fine is lower compared to conventional sand by 18%. All of them showed a substantial decrease in density within a limit of 1950 kg/m^3 to 2260 kg/m^3 . This was also reported by other researchers when other of types of lightweight waste materials are utilised (Siddique et al., 2008; Abd. Aziz et al., 2014; Ledesma et al., 2015). As a comparison to control mortar (NML), a reduction of about 7.0% was obtained when sand is totally replaced with POC fine. Besides lower density of POC fines itself, the decrease in density is also highly influenced by the presence of substantial amount of voids (either macrovoids or microvoids) within the aggregate interface. These voids increase the porosity within the mortar. This lowers the mass per unit volume of the aggregate itself to give a lightweight nature to the mortar component. A microstructure study performed on POC aggregates supported this finding (as described in Section 4.2.2). Despite this

reduction, these mortars did not attain the lightweight mortar criteria (density less than 2000 kg/m^3).

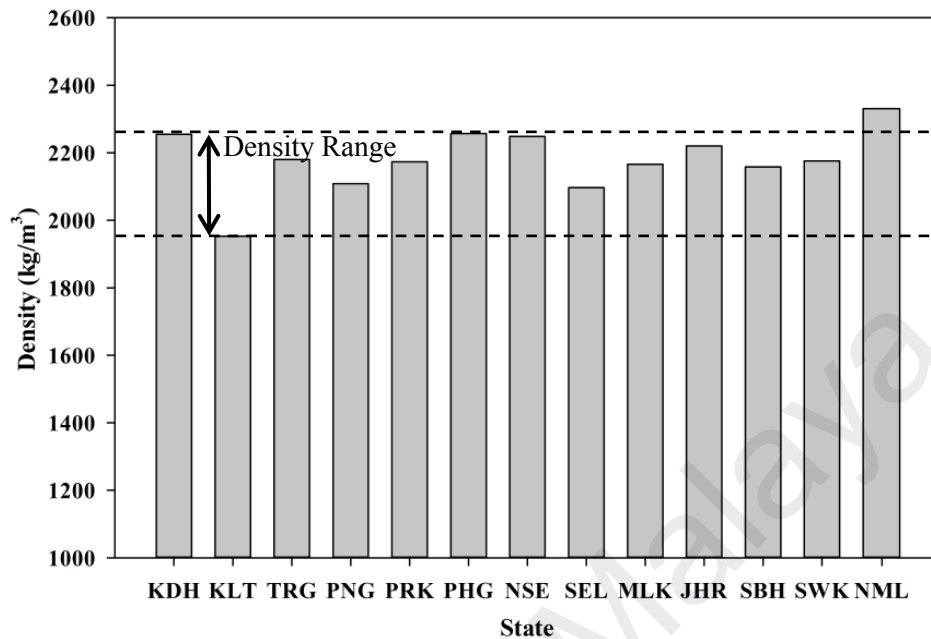

Figure 5.3: Variation in density for the samples from each state

5.2.3 Compressive Strength and Structural Efficiency

Compressive strength is one of the major deciding factors that govern the suitability of the material for use in concrete or mortar. The study was limited to mortar phase only due to the transport and economic constraints of collecting POC samples from each state in Malaysia. Figure 5.4 shows the compressive strength properties of mortar cubes incorporating POC from each state in Malaysia. A minimum of three 50mm^3 cubes were prepared for this test by incorporating the POC state samples into SCM. A reduction of strength was observed when the POC was incorporated in the mixes. The weaker aggregate crushing value (ACV) of POC aggregate affects greatly the load bearing capacity of the mortar. This may be due to the highly porous nature of POC with immense macro and micro voids that decreases the strength of the aggregate. This increases the void ratio in the mortar to allow for quick crack propagation as well as failing rapidly under applied load (Corinaldesi & Moriconi, 2009; Koksall et al., 2015). Figure 5.5 depicts the structural efficiency (SE) values for POC fine samples from

different states in Malaysia. As observed, mortar sample from Kelantan exhibited the highest SE values contributed by the lower density of the aggregates itself. Despite that, it is able to produce significantly high strength compared to any other state mix. This may be due to the presence of higher silicon oxide (SiO₂) compounds for Kelantan samples compared to other states (as observed in Table 4.12). All the state samples showed SE values within a range of 0.35 to 0.50 MPa / kg/m³. The values obtained are much higher than that of the industrial waste lightweight aggregate such WPLA (Choi et al., 2005) which indicates a satisfactory performance of POC as aggregates in mortar or concrete .

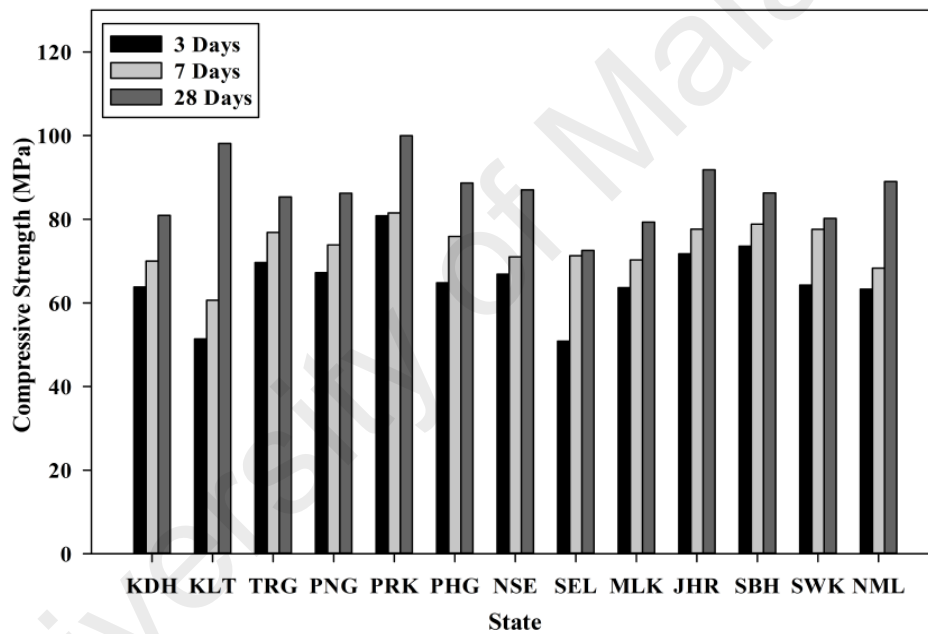

Figure 5.4: Compressive strength of POC samples from each state in Malaysia

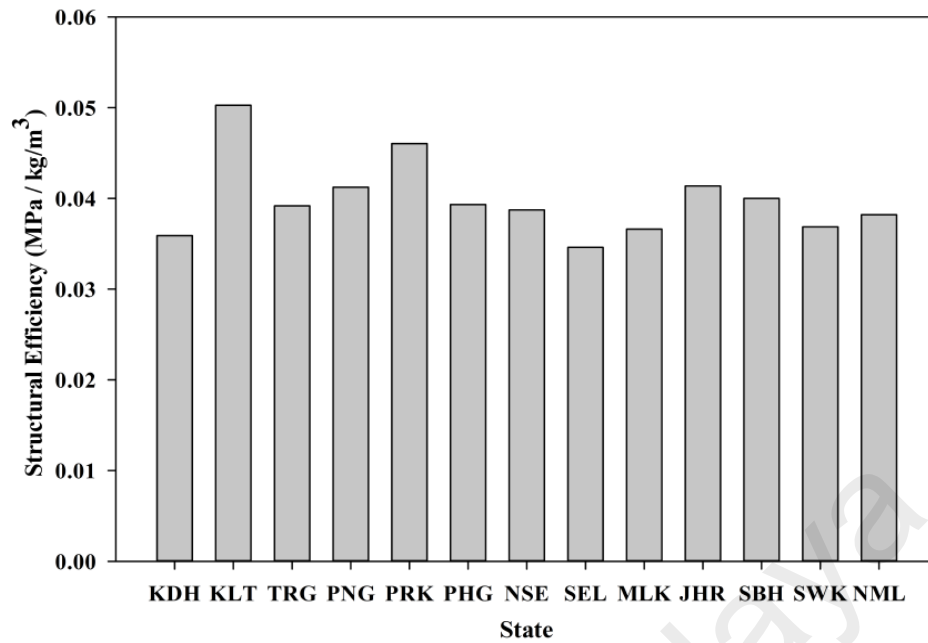

Figure 5.5: Structural efficiency for POC samples from each state in Malaysia

5.2.4 Flexural Strength

Aggregate impact value (AIV) could be a good factor to consider in explaining the significant reduction in the flexural load retaining property of POC aggregates. Figure 5.6 shows the flexural strength of mortar beams for all states in Malaysia. A minimum of three test mortar prisms of size 40 mm × 40 mm × 160 mm was prepared for this test. The test was carried out as outlined by ASTM C348 (2014). The lower AIV and ACV for POC gave a significant effect to the maximum load the mortar beams can take upon rupture. Upon observing the flexural strength test, all the samples broke into half at their respective maximum load indicating the high brittleness of the mix. This can be explained through the lower AIV which are obtained for POC aggregates which is about 40% to 44% generally. AIV which is also an indicator of toughness confirms the very low toughness behaviour of POC to produce high brittleness ratio. It should be noted that some of the samples showed greater flexural strength results compared to the control specimens. Correspondingly, the samples that showed higher strength results were composed of greater SiO₂ content. Hence, the strength of the aggregate against the

flexural behaviour might be higher than the control samples (NML). From microstructural point of view, the micro-crack creation is much more rapid when POC is incorporated as the interface between cement and POC is relatively weaker due to presence of substantial voids. Despite that, it can be concluded that the flexural strength remains within 8MPa to 14MPa for all state, which is still within the limits obtained by other researchers for other type of waste materials (Safi et al., 2015).

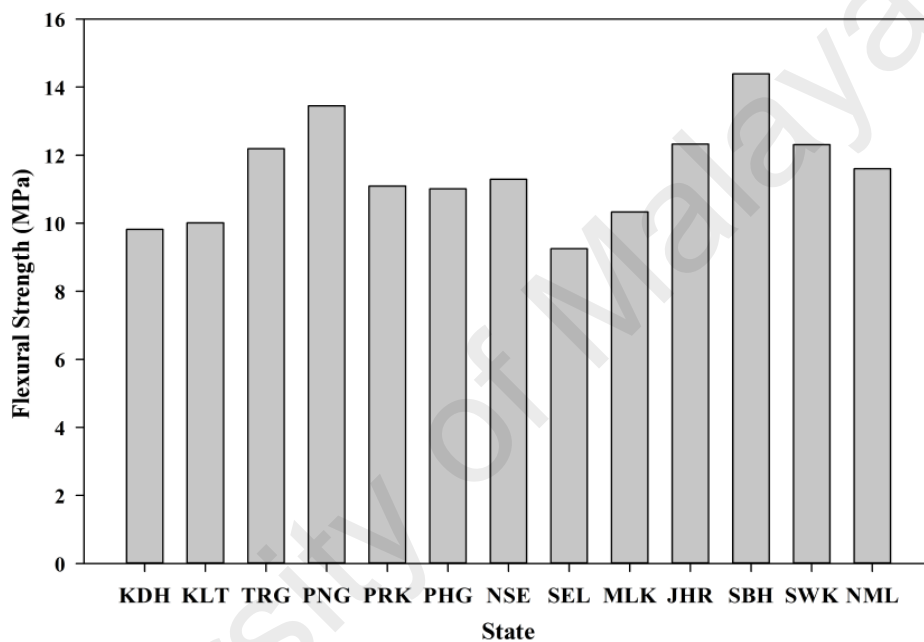

Figure 5.6: Flexural strength results for POC samples from each state in Malaysia

5.2.5 Microstructural Analysis

A randomly selected SCM sample was taken to analyse the POC fine aggregate cement paste matrix interface with the aid of scanning electron microscope (SEM). It is vital to study the interface as it provides an indication on the hydrates and bond characteristics. Figure 5.7 shows the cement-aggregate interface. An ordinary or routine formation of calcium silicate crystalline phase and calcium hydroxide elements can be observed clearly which is also present in any type of conventional mortar or concrete. Under very low magnification, a detachment can be observed between the aggregate and cement paste. In addition, micro voids on the POC aggregates are also visible to

confirm the characteristics of POC. Figure 5.8 depicts the SEM image of a POC aggregate-cement interface from Sabah. From the energy dispersive X-ray (EDX) results in Figure 5.9, the higher silica (Si) (SPOT 1) and calcium (Ca) (SPOT 2) peaks corresponding to the POC aggregate and cement paste, respectively, indicate the boundary between the aggregate and the cement paste. A packed or dense state of aggregate cement paste interface is evident as a myriad of SCM properties. Higher paste content coupled with enhanced workability improved the aggregate cement paste region to provide a better bond formation. A past study confirms that SCC generally brings down the void content on interface which promotes towards enhanced homogeneity to create an evenly distributed pore sections (Elinwa et al., 2008). Besides that, the irregular shape and rough surface texture of POC induces a strong bond between the aggregates which can be evaluated through the minimal loss in strength of POC fine mortar specimens. This was discussed before by other researchers who reported that if the surface roughness is high, there is a possibility of having an increment in the interface bond strength (Hong et al., 2014). The surface roughness effect was more dominant for POC when they are subjected to flexural load, as the interlocking behaviour is greater. However, the weaker POC aggregate compared to the paste dominates the failure mechanism as it might produce quick failure within the ITZ of the mortar due to its lower crushing value.

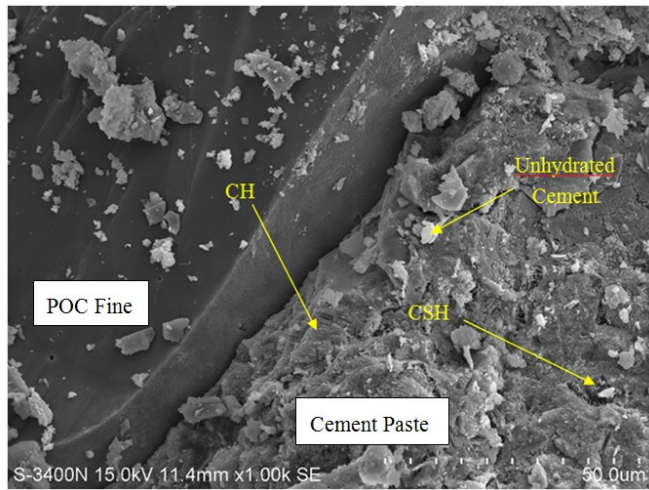

Figure 5.7: Aggregate cement paste interface ; CH=calcium hydroxides, CSH=calcium silicate hydrates

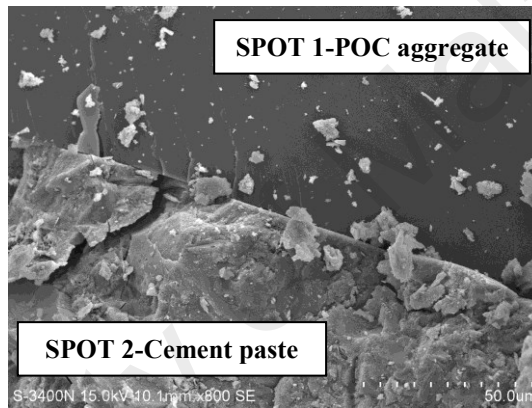

Figure 5.8: POC aggregate - cement paste interface

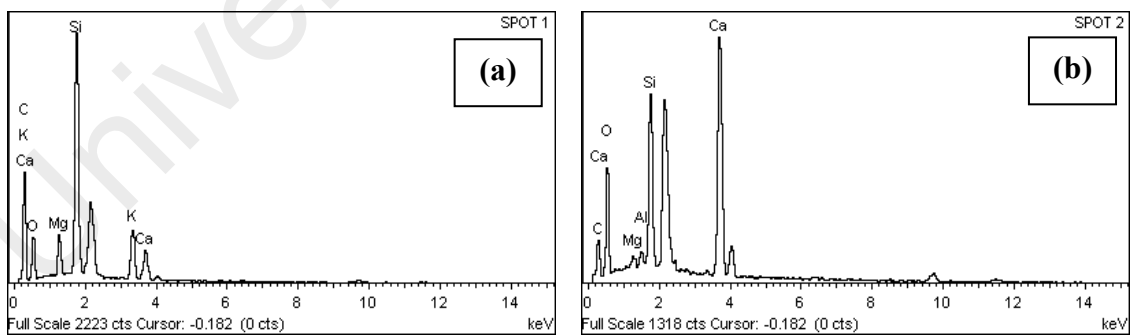

Figure 5.9: EDX of POC aggregate - cement paste interface – (a) Spot 1 and (b) Spot 2

5.3 Evaluation of POC Powder Self-Compacting Mortar (SCM)

The mix design method employed in this study required an additional paste volume to satisfy the self-compactability characteristics of POC. In this study, the effect of POC powder as a replacement material for cement was evaluated. Despite having alternatives

for choosing other types of powder materials such as fly ash, silica fume and limestone powder, POC powder was selected specifically to allow for maximum utilisation of palm oil mill waste. Besides replacing aggregates, consumption of this powder in place of cement could also reduce the cost and greenhouse gas (GHG) emissions problems. A study on the fresh and hardened properties of SCM incorporating POC powder is vital to understand the positive effects of using it in the concrete. Although the overall study does not entirely focusses on POC powder, simple analysis was required to obtain quantified results of the powder performance in concrete. Mortar specimens were used instead of concrete specimens to reduce the effect of coarse aggregates on the hardened properties. Aggregate (sand) parameters such as fineness modulus of sand, sand gradation, specific gravity of sand and water absorption were kept constant throughout the study to ensure that POC powder is the only manipulating variable. Moreover, the mixing procedure was also kept same to evaluate the complete fresh properties of POC powder SCM. This study will help to further explain other behaviour of POC concrete when coarse and fine POC are incorporated. The mix proportion for self-compacting POC powder mortar is tabulated in Table 5.2. In addition, simple environmental assessments and sustainability assessments (will be discussed in chapter 6) were carried out to evaluate the savings and benefits of introducing POC powder in concrete. These values may help to contribute to the later assessments involving concrete on a greater scale.

Table 5.2 : Mix proportion for self-compacting POC powder mortar

Mix	Sand (kg/L)	Cement (kg/L)	POC Powder (kg/L)	W/B	S.P Dosage (%)
POC 0	1.14	0.91	0.00		
POC 5	1.14	0.86	0.05		
POC 10	1.14	0.81	0.09		
POC 15	1.14	0.76	0.13	0.29	0.50 – 0.80
POC 20	1.14	0.71	0.18		
POC 30	1.14	0.62	0.26		
POC 40	1.14	0.52	0.35		
POC 50	1.14	0.43	0.43		

*POC 20 - refers to replacement of 20% cement with POC powder

5.3.1 Fresh Properties

The fresh state of POC powder SCM mixes was evaluated with slump flow test. Figure 5.10 depicts the slump flow range for POC powder mortar at different POC replacement percentage (%). The range of flow diameter was kept between 250 mm and 290 mm throughout the study to ensure consistency of the mixes which is in a smaller range as suggested by other researchers (Domone & Jin, 1999; Benabed et al., 2012). SCM was selected as it ensures good surface finishing and enhanced hardened properties. In this case, when cement is replaced with POC powder, the slump flow values tends to increase minimally at a higher replacement ratios. Generally, the workability retention of concrete is highly dependent on availability or depletion of free water in concrete as they get hydrated or absorbed by dry aggregates (P Kumar Mehta, 1986; Soroka & Ravina, 1998; Ahmad & Azhar, 2004; Erdođdu, 2005). The presence of free water that is neither absorbed by POC powder or aggregates increases the slump flow diameter which is contrary with other types of mineral admixtures or fillers such as silica fume, metakaolin and RHA. This trend was also observed for limestone powder whereby at higher replacement the slump flow diameter increased concurrently as a

result of reduction in yield stress and viscosity (Zhang & Han, 2000; Adjoudj et al., 2014). From another point of view, cement which is replaced with a lower density POC powder reduces the friction between paste and fine aggregate zone. This in turn enhances the cohesiveness and plasticity of the mix to produce mix with a lower yield stress due to improved workability (Paiva et al., 2006; Jiménez-Quero et al., 2013). It should be also noted that there is a reduction in slump flow values at the smaller percentage of POC powder replacement. This behaviour can be explained from the particle size distribution of cement and POC powder. As observed from Figure 4.8, the fineness of cement and POC powder are with small variation. There is a possibility that at a lower replacement level, the bonding or pore filling of POC powder into the arrangement of cement are much better creating less friction within the mixture. Meanwhile, as the replacement level increases, the presence of greater POC aggregates creates higher interparticular friction that results in greater slump flow diameter. Apart from that, a rheological study was also carried out to quantify the shear stress and viscosity as cement is replaced with POC powder.

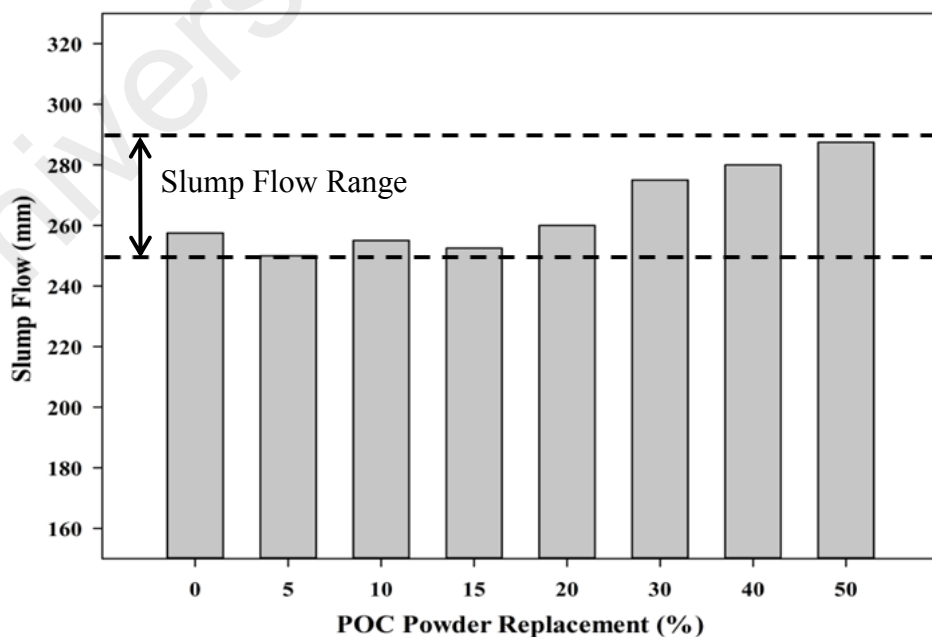

Figure 5.10: Slump flow results for POC powder mortar

5.3.2 Rheological Behaviour

The rheological behaviour of POC powder SCM plays a vital role in exhibiting the fresh state properties. Since this is the first attempt to utilise POC powder in mortar and concrete, a thorough assessment is required to report every aspect of the incorporation to establish the advantages for mass production. It is important to characterise any material that are used in concrete especially in SCC due to the very fluid and heavy suspension of aggregates. POC powder was incorporated in SCC to supplement the need for extra paste as required from the PP method of mix proportioning. The viscosity and flow behaviour of POC powder SCM was characterised through rheological test. The outcome of the study would assist in understanding the effect of POC powder when used in SCC. Figure 5.11 illustrates the viscosity changes of all POC powder SCM with respect to increasing shear rate. Meanwhile, Figure 5.12 shows the shear stress changes with POC powder replacement. A ‘shear thinning’ behaviour of the SCM is obvious from the decreasing viscosity graph pattern. Generally, all the mixes showed reduction in viscosity rate as the rotational speed was increased irrespective of the POC powder content. As observed, an increase in POC replacement lowered the viscosity of the mortar by almost 600% compared to control mix. It should be noted that all the mixes showed pseudoplastic behaviour as a function of time dependent shear rate. This can be explained through the higher viscosity properties at lower deformation rate and lower viscosity at higher deformation rate to become more flowable. This properties was also reported by Felekoğlu et al. (2006).

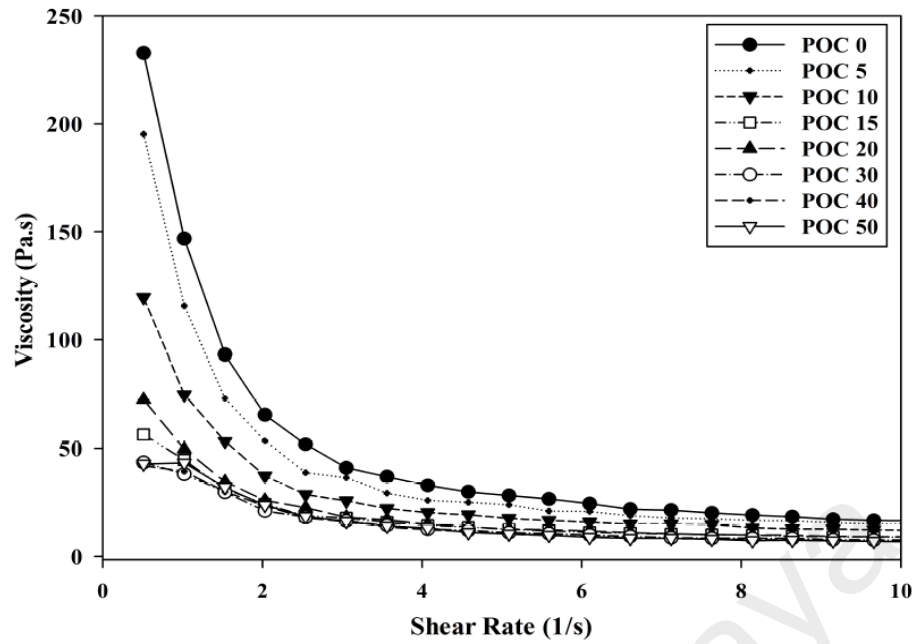

Figure 5.11: Relationship between shear rate and viscosity of POC powder SCM

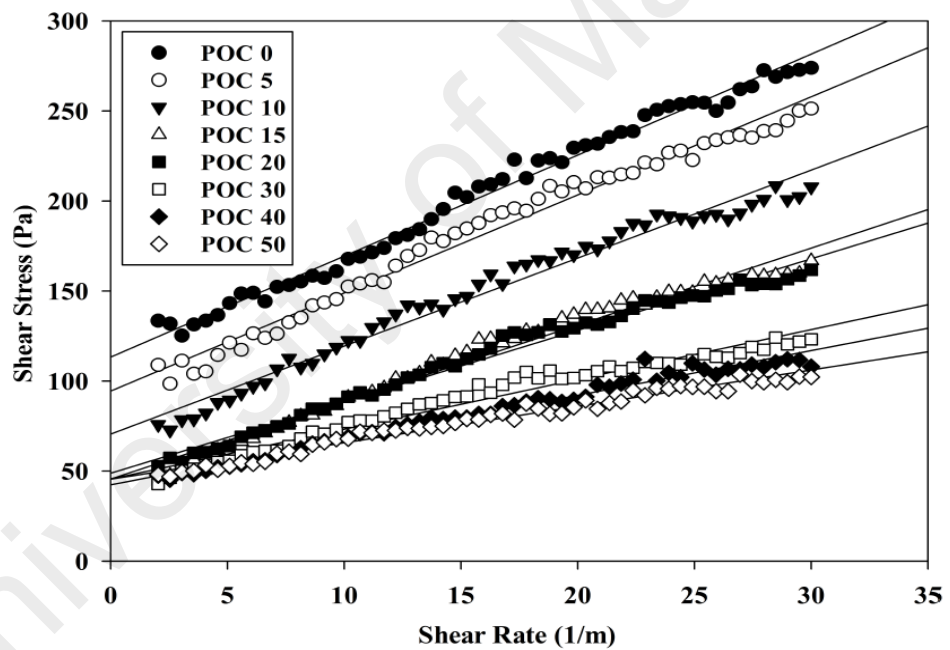

Figure 5.12: Relationship between shear stress and shear rate of POC powder SCM

The dilution effect of POC powder plays an important role in exhibiting lower viscosity behaviour as the substitution level increases. As previously described, POC powder is majorly composed of silica whereby it does not have significant hardening agent or cementitious material that will increase the viscosity with respect to time. Thus, the water provided to the mix adapting similar water binder (W/B) ratio throughout the study probably was only reacting with cement to become hardened. Although POC

powder does mix with water to achieve certain viscosity state, the rather non-significant cementitious properties reduces the reaction rate and it remains in its original state majorly. Test was carried out by diluting only POC powder with water to achieve a 'paste' consistency at different W/B ratio. They were casted using 50mm cubes. All the samples collapsed upon demoulding after 24 hours proving that POC powder maybe a just filler material. At a higher replacement rate, the POC powder is not helping the cement content to set which eventually increases the setting time of the mortar due to limited cement availability. This increases the water cement ratio of the mix to reduce the viscosity of the material. This in turn reduces the shear stress among the mix which is evident from the stress viscosity relationship and slump flow results obtained.

Figure 5.13 shows the correlation between yield stress and slump flow of POC powder SCM. The lower yield stress induced by the presence of less dense POC powder gave lower stress on the POC SCM mix to produce greater slump flow diameter. Specific gravity of POC powder which is 22% lower compared to cement reduced the weight of the mix. Secondly, the characteristics of the POC itself affects the mechanism of SCM whereby the influence by the shape, texture, particle size distribution and angularity is prominent (Felekoğlu et al., 2006). Moreover, different particle shapes of cement and POC powder particles may create a poor bond between them. Besides that, the variation in the particle size distribution between POC powder and cement may induce different bonding mechanism leading to significant difference in the flow properties. As observed from $D(v,0.5)$ values, POC powder is much finer by 25% on average compared to cement (as tabulated in Table 5.1). This may affect the bonding properties as the different particle size intervals may produce varying interlocking bond, thus leading to reduction in fresh properties.

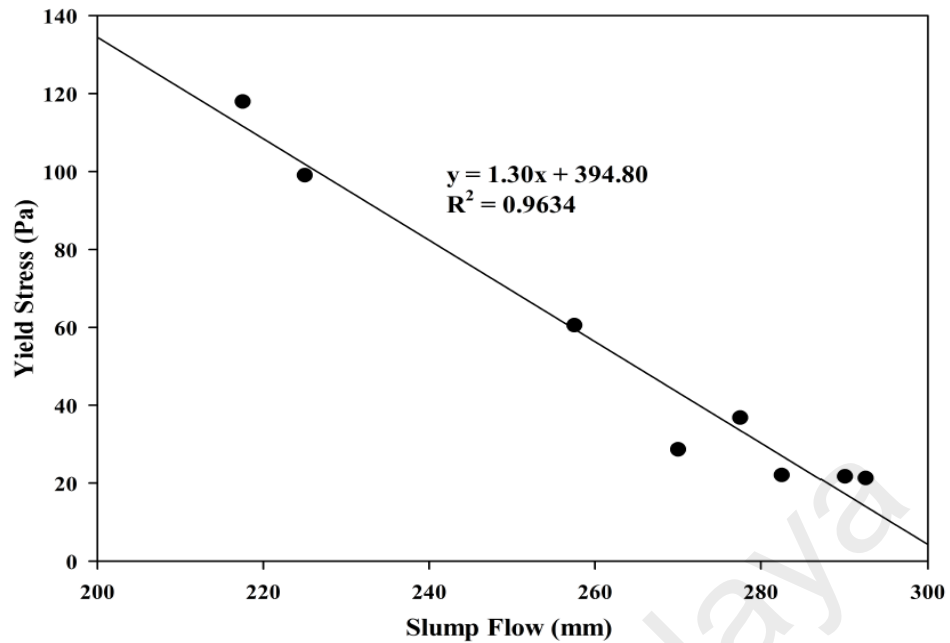

Figure 5.13: Correlation between yield stress and slump flow of POC powder SCM

Figure 5.14 shows the correlation between V-funnel flow time and viscosity at five revolutions per minute. It is generally accepted that V-funnel flow time test is an indirect measurement of the flowability or viscosity of SCM or SCC. It should be noted that a mix starts to flow when the yield stress of the mix is exceeded whereby a linear relationship between shear stress and strain can be observed. This portion of graph can be defined as plastic viscosity or sometimes referred as the rate of flow (Benabed et al., 2012). It is well known that a higher viscosity value will result in a greater V-funnel flow time (Felekoğlu et al., 2006; Güneyisi et al., 2009). As of this study, the POC powder tends to reduce the viscosity of the mix due to the dilution effect. The viscous state of the mix is reduced as the availability of cement to bind the mixture is greatly lowered as the ratio of cement to POC powder reduces.

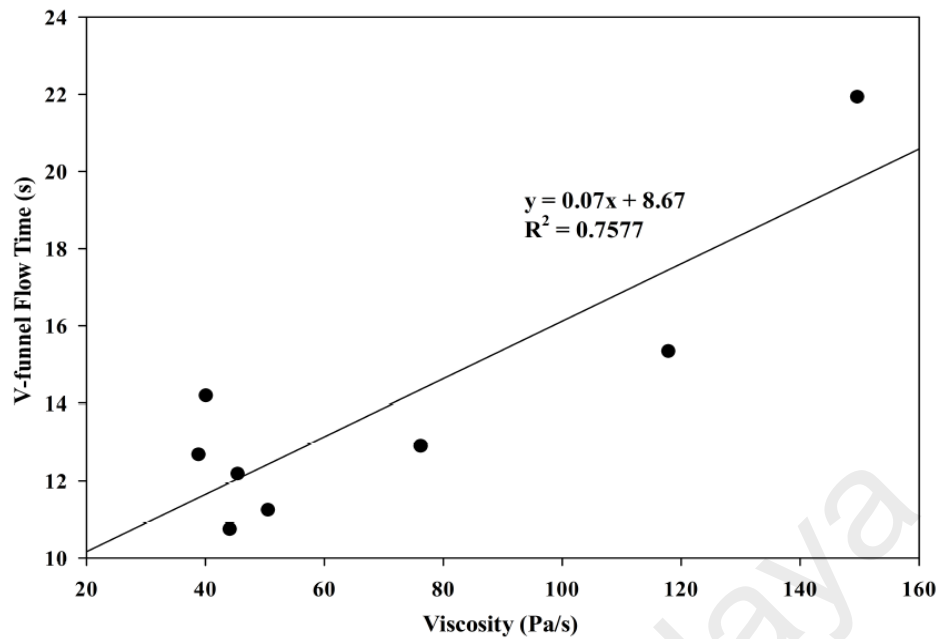

Figure 5.14: Correlation between V-funnel flow time and viscosity at 5 rev/s of POC powder SCM

5.3.3 Compressive Strength

Figure 5.15 shows the evolution of compressive strength of mortars as a function of POC powder content. Comparing the results up to 180 days, the strength attainment for the POC replacement samples at later stages did not exceed the strength of the control specimens. However, it should be noted that the 50% replacement mix gave a strength value of about 70% of the control mix. Figure 5.16 depicts the relative compressive strength of POC powder specimens at different replacement levels with a reference study (Ref) by Hewlett (2003) on OPC-pozzolan mortar mixes. It is apparent that the trend of the POC mixes is opposite to the trend compared with the reference mixes. Thus, it supports the dominance of the dilution and filler effects for the POC mixes since there is no significant strength gain as compared to the control mix in this study. In general the optimum cement replacement level with a pozzolanic material is 20%. Thus a comparison with a pozzolanic material such as fly ash at the same replacement level will give some indication of the pozzolanic reactivity of the POC powder. From this study, the late strength gain for 20% POC powder replacement is only about 12%

for the period between 28 and 90 days. In comparison, based on literature, SCM incorporating 20% fly ash produced approximately 20% strength gain for the same period (Razi & Abdul Razak, 2012). Despite having similar amorphous content, the strength pick up for POC powder is considerably lower indicating that it is a weak pozzolan compared to fly ash. If, however, there is significant pozzolanic reaction of the POC powder, a relative strength gain at 28 days and later should be noticeable in the trend giving higher strength values compared to the control. This trend can be observed for other replacement materials which are pozzolanic in nature such as fly ash, rice husk ash and POFA. Despite that, POC powder satisfied the requirements of ASTM C618 for local class of pozzolans indicating the material might have low pozzolanicity properties. The early strength achievement for the POC mixes was relatively slow compared to that of the control mix. The dilution effect could be one of the reasons behind the strength loss when cement is replaced. For the higher level of POC powder replacement, the availability of excess water from the dilution effect lowers the rate of the hydration process.

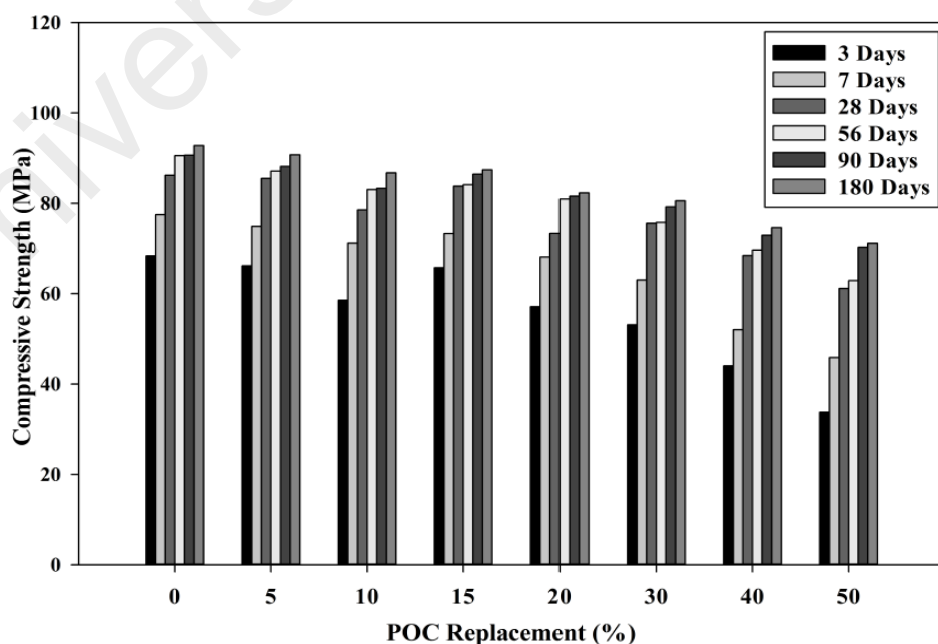

Figure 5.15: Evolution of compressive strength of mortars as a function of POC powder content

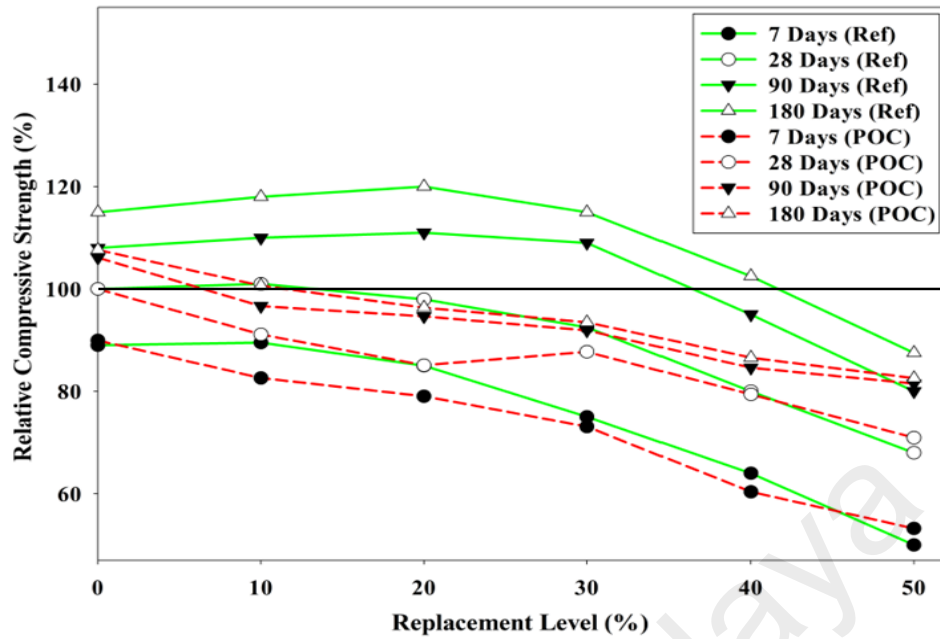

Figure 5.16: Comparison of relative compressive strength between POC powder and OPC-pozzolan mortar mixes (Adapted from (Hewlett, 2003))

From another point of view, addition of POC powder increases the availability of non-cementing agents in the mix than cementing cement content. This is in line with findings by Pliya and Cree (2015). Figure 5.17 shows the compressive strength drop analysis for each POC replacement. From the analysis, a similar pattern was observed for a typical PFA. For POC 50, at three days of curing, almost 49% strength loss was observed compared to the control mix. The evolution of strength for the POC powder incorporated mixes improved at later ages where at 28 days almost 70% of the strength could be achieved by the POC 50 mix. Researchers have also reported that the availability of a high amount of pores, which results in a state of high permeability could also affect the mortar strength achieved (Calmon et al., 2014). Again, the poor packing between the cement and the POC powder due to size difference and shape may contribute to the strength loss. In addition, the distribution of POC powder also greatly contributes towards strength loss. According to P.K. Mehta (1986) cement particles within a range of 10–45 μm delays strength properties while below 10 μm contributes towards early strength. A qualitative assessment of the particle size distribution from

Table 5.3 shows that 37.86% of the POC powder is finer than 10 μm compared to that of cement, which is only 27.58%. At a higher level of replacement, the early strength of the mortar specimens is much lower, which may be due to the highly substituted finer cement particles with non-reacting POC powder. In addition, the strength differences reduce drastically at a later age (28 days), which comes from the lower replacement of cement with POC powder in a range of 10–45 μm . The availability of high cement particles despite the higher replacement rate helps in respect of the late strength achievement.

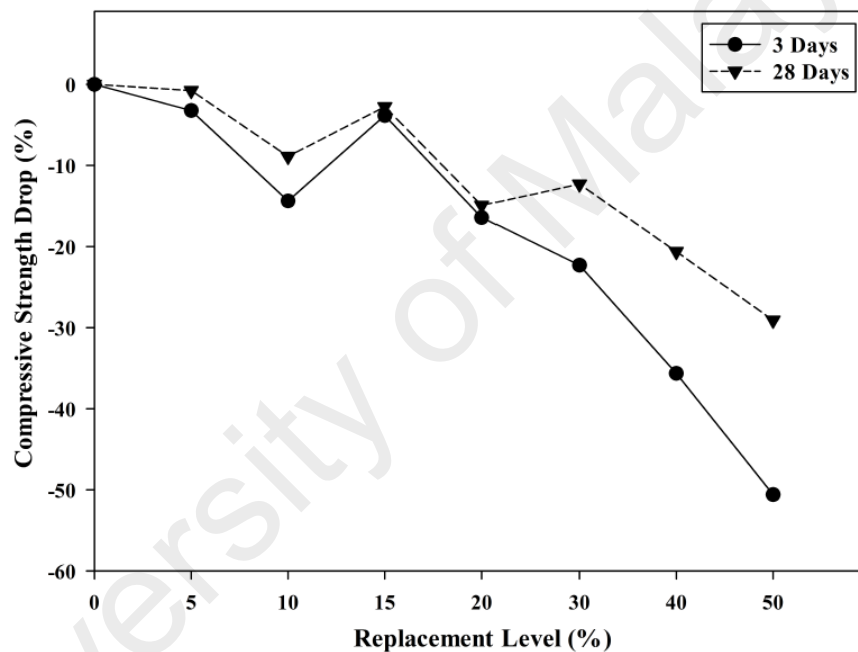

Figure 5.17: Relationship between POC powder replacement and compressive strength drop

Table 5.3: Particle size distribution of cement and POC powder

Properties	Cement	POC Powder
Average size, $D(v, 0.5)$	27.98 μm	20.97 μm
Passing 10.48 μm (%)	27.58	37.86
Retained 10.48 μm , Passing 48.27 μm (%)	45.80	34.05
Retained 48.27 μm (%)	26.62	28.09

Figure 5.18 shows a plot of the cumulative strength difference between three days and 28 days of hardened specimens against the POC powder replacement level. “Cumulative values of strength” was computed by accumulating the strength differences between three days and 28 days for each replacement level. Equation 22 shows the formula to calculate the cumulative compressive strength. The cumulative values of the strength difference show the possible replacement level that could provide good strength achievement even though the cement is replaced continuously. As observed, almost identical values in the strength drop between the 10% and 20% replacement level (as indicated by the dashed box) were obtained indicating that the decrease in strength for early age (three days) and later age (28 days) was similar despite increasing the POC powder replacement. It can be deduced that within this replacement level, the combination of cement particle size contributing to the early and later strength is almost identical, thus minimizing the drop in strength. Beyond 20% replacement, the POC powder takes out more of the cement particles of 10 μm and below, and, as a consequence, there is more inert material leading to higher strength loss at an early age.

$$\text{Cumulative Strength difference (\%)} = \frac{\sum \text{Strength (28 days - 3 days)}}{\text{Control strength}} \times 100\% \quad (22)$$

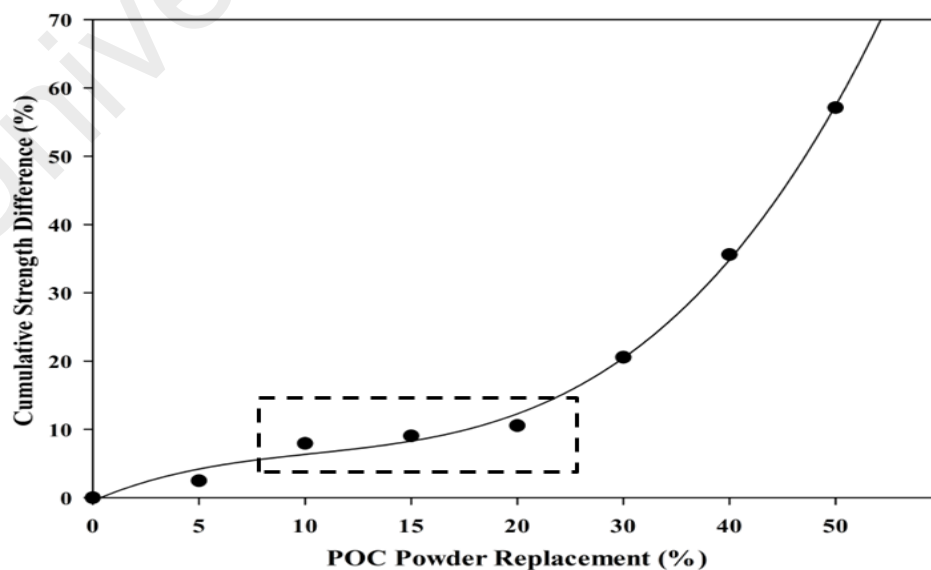

Figure 5.18: Relationship between cumulative strength difference and POC powder replacement

5.3.4 Ultrasonic Pulse Velocity (UPV)

The packing level of the aggregates and paste can be established using the UPV test. Previous studies have mentioned that SCC usually has a better interfacial transition zone (ITZ) and properly distributed voids within the concrete (Elinwa et al., 2008). Figure 5.19 shows the evolution of UPV values as a function of POC powder replacement. SCM tends to have a better interface between the aggregate and paste due to its self-compatibility nature whereby they integrate well to form an enhanced structure. The packing level of the aggregate and paste are further enhanced as the amount of voids or empty regions within the mortar specimens are minimized. As observed from the SEM morphology of the POC powder (as showed in Figure 4.5 and 4.6), the irregular shapes of the POC powder may exhibit poor packing capability when replaced with cement particles.

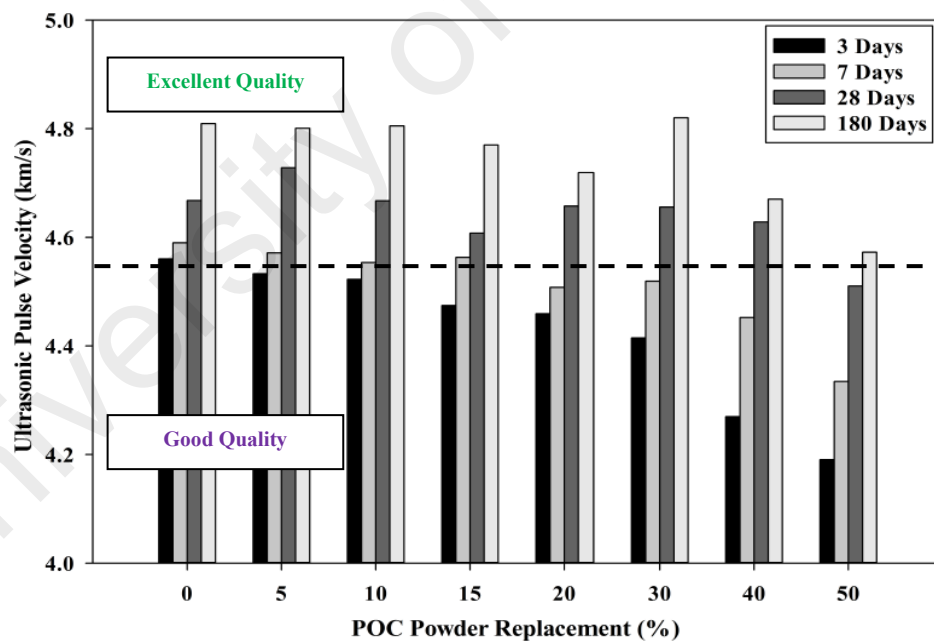

Figure 5.19: Evolution of UPV values as a function of POC powder replacement

The difference in self-compactability properties obtained through POC powder incorporation which was observed through fresh properties may also affect the pulse transfer rate. As discussed earlier, the presence of voids due to the POC powder shape may reduce the packing level of the mix to produce lower structural performance. This

may be indirectly shown by the slightly lower UPV values for specimens at higher replacement rates. The presence of higher micro voids left by the poor interlocking effect may induce an empty void zone, which may reduce the pulse transfer (Koksal et al., 2015). In addition, the strength development pattern due to the POC powder can also be observed through the UPV values. Although the reduction in strength for the POC powder samples provided a lower pulse transfer compared to the control specimens, the incorporation of POC powder showed satisfactory results as previous studies reported that UPV values of between 3660 and 4575 m/s can be deemed as “good” quality (Hwang et al., 2012). As observed from the results obtained in this study, at 28 days almost all the UPV values were well above 4500 m/s which can be categorised as “excellent” quality. Although the range was provided for concrete mainly, it can be also used relative to the control mortar specimens for a comparison purpose. The difference in the UPV readings between the control mortar and POC powder mortar indicates the possible effect of shape and nature of POC powder.

Figure 5.20 illustrates the correlation between UPV values and compressive strength. It would stand as a good indicator on the possible strength achievement at different ages (Kewalramani & Gupta, 2006; Hamid et al., 2010; Koksal et al., 2015). Moreover, it is worth to note that the degree of compaction in concrete structures can be assessed without having to cut the matrix of the samples through UPV test (Neville, 1973). Generally POC powder inclusion reduced the strength which was also observed through UPV values. The effect of POC powder shape and particle size distribution may have contributed towards lower strength besides giving lower compaction properties.

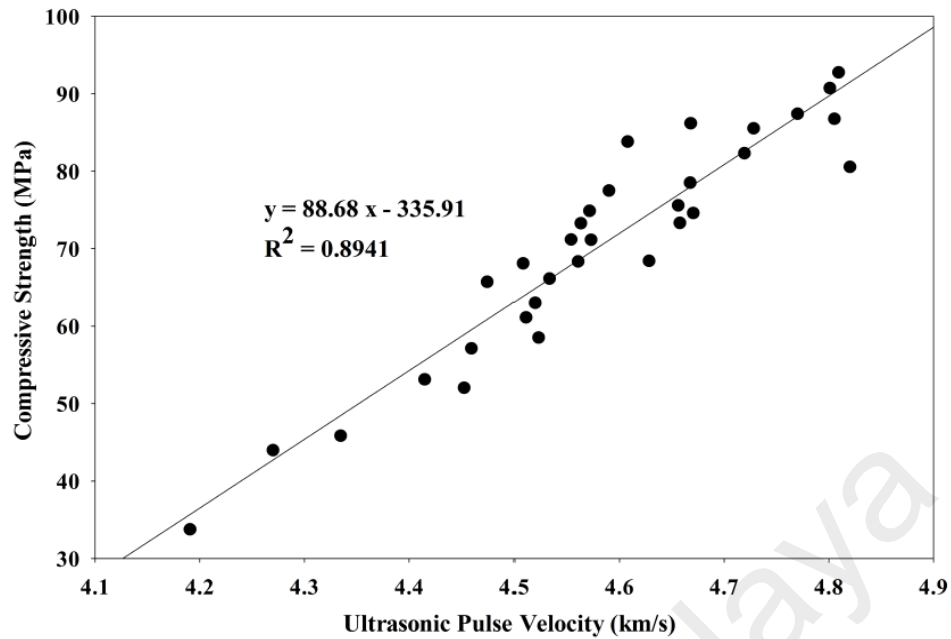

Figure 5.20: Correlation between UPV values and compressive strength for POC powder mortar specimens

5.3.5 Flexural Strength

Figure 5.21 shows the relationship between the replacement of POC powder and the flexural strength obtained. Mortar prisms of size 40 mm × 40 mm × 160 mm were used in this study. The test was performed as stipulated by ASTM C348 (2014). Although POC powder is being replaced with cement at a very high substitution rate (50%), the drop in the strength was only about 4 MPa lower than the control specimens. As observed, the flexural strengths were within a range between 8 MPa and 12.2 MPa. Despite replacing cement with 50% cement, almost 69% of flexural strength can be achieved at maximum replacement (POC 50) relative to the control specimens. The bond between the aggregate with significantly reduced cement content could provide some indication concerning the effectiveness of the powder to act as a binder to enhance aggregate paste interface. This affects the load bearing capacity of the aggregate paste structure. Besides that, the irregular and non-uniform shape of POC powder particles could also provide some effect to the flexural strength achievement. At higher replacement levels, the flexural strength is much lower which was probably contributed

by the poor mortar structure formation due to the presence of POC powder particles. A SEM test was carried out to investigate the boundary between the aggregate and the binder (will be discussed in section 5.3.7).

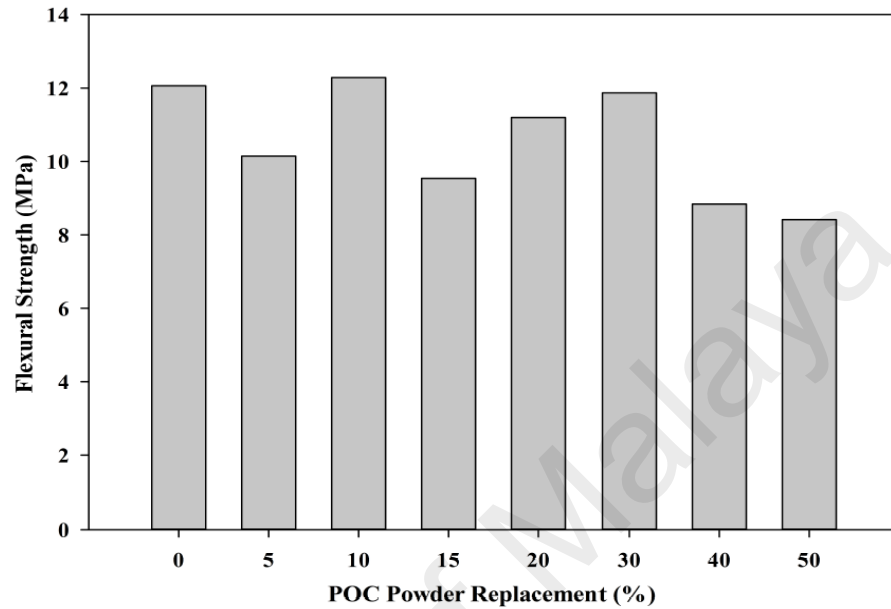

Figure 5.21: Relationship between POC powder replacement and flexural strength

5.3.6 Structural Efficiency

Figure 5.22 shows the structural efficiency of the samples incorporating POC powder. The structural efficiency concept was introduced and evaluated to have a similar platform for comparison between POC and non-POC (control) incorporated samples (Choi et al., 2006). At a higher replacement level, a reduction in strength was observed as the POC material is acting as a filler material besides having pozzolanicity properties which are rather not significant. The blend of binder between the POC powder and the cement produced a lower strength indicating a poor bond between the cement and the POC powder molecules. In addition, the POC powder acts as an inert material and creates a dilution effect within the hardened mortar structure. Although POC 0 showed significantly better efficiency values, POC powder samples do achieve satisfactory values. At the maximum replacement level, they are able to attain approximately 74% of the structural efficiency compared to the control samples.

Integrating both the environmental impact and engineering aspects, the mixes incorporating POC powder definitely provide satisfactory output, which are suitable for application in the construction industry.

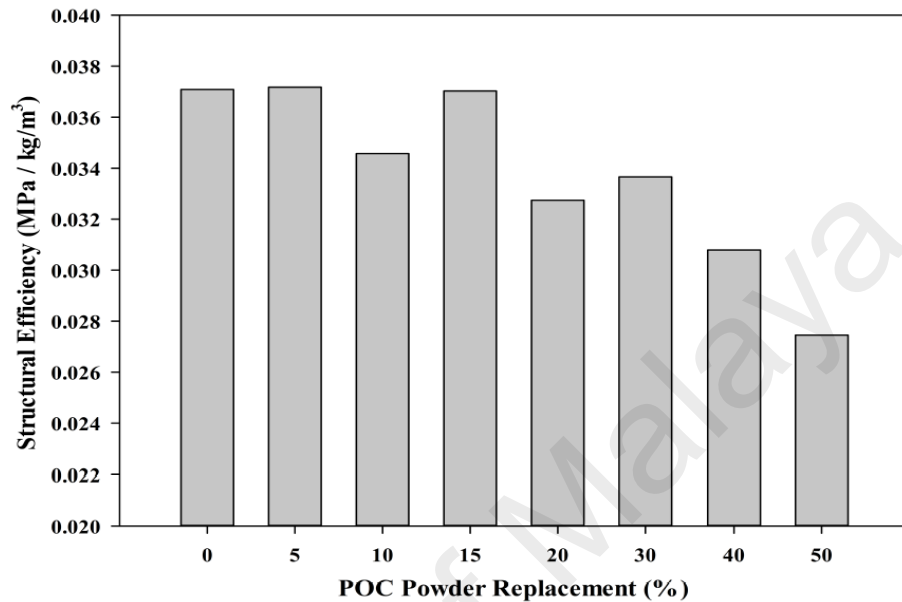

Figure 5.22: Structural efficiency of POC powder mortar specimens

5.3.7 Microstructural Analysis for POC powder SCM

The boundary between aggregate and paste for POC powder was studied through SEM test to understand the effect of adding POC powder on the microstructure of the mortar formed. However, through SEM examination it is not possible to quantify or determine the presence of POC powder as they tend to bind with cement particles. Figure 5.23 shows the POC 0 and POC 40 interface obtained through SEM studies, respectively. As observed, use of SCM improved significantly the aggregate cement interfacial zone due to its ability to fill the voids and take up the shape of the interacting boundary. This indeed may be the reason behind the high strength sustaining capacity of the mortar even with a higher POC powder replacement. A qualitative assessment on the cement paste region confirms the difference in the quality as cement is replaced. Solid and evenly distributed sections are visible for POC 0 confirming the denseness

and highly packed cement only state. Conversely, for POC 40, a relatively weaker region can be observed through the segmentation of cement – POC powder paste mix. This may be contributed by the shape of POC powder itself which are irregular which could lead to formation of uneven structure. Besides that, the variation in the particle size distribution between cement and POC powder at different size intervals also adversely affected the formation of good bond which results in a lower paste strength (as discussed in Section 5.3.3).

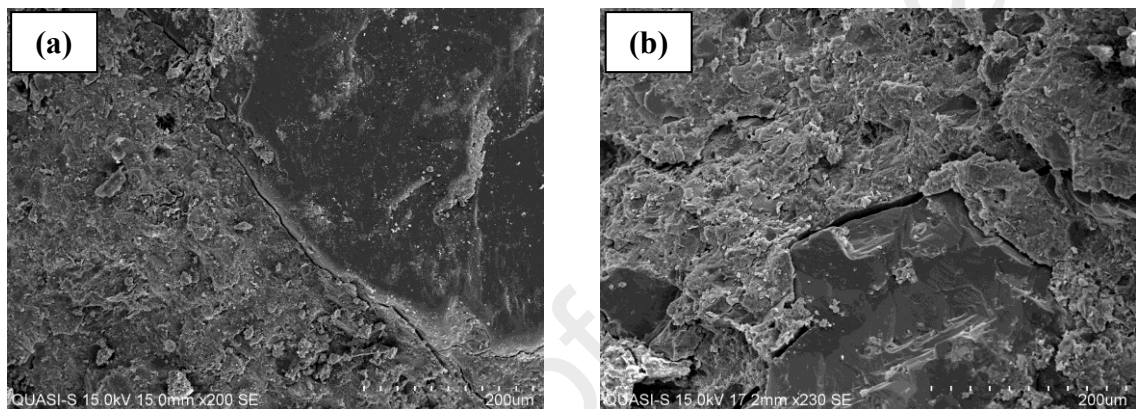

Figure 5.23: Aggregate paste interface (a) POC 0 and (b) POC 40

5.3.8 POC Powder SCM Elevated Temperature Test

Figure 5.24 shows the effect of elevated temperature on the relative strength and mass loss for different POC powder replacement levels. A good improvement in strength was observed at 250°C generally for all replacement levels. It could be due to the loss of interlayer water and water presence within C-S-H and sulphoaluminates hydrates (Mehta & Monteiro, 2006). Despite having higher replacement level, the mass loss for all replacement level remained constant. POC which are originally burned at high temperature during the processing stages in the palm oil mill may not react further upon this temperature and may remain as filler. When the temperature was increased to 500°C, the mass loss increased to an average of 5.20%. Figure 5.25 depicts the effect of POC powder on UPV values. At 250°C of heat exposure, the UPV value decreased marginally for most of the samples. Although strength improvement was observed,

dehydrated water from the mortar may have created voids within the specimen which resulted in UPV reduction. Upon reaching a higher temperature, the ITZ may have been damaged as the decomposition of the cement particles may have started to take place considerably. A notable trend was observed whereby the decrement level was similar for all replacement level. This confirms that the samples still maintain the same bonding irrespective of POC powder replacement. From another point of view, it shows that POC powder well gelled with cement particles and presence of this waste material did not cause any detrimental or deterioration effects to the matrix of the mortar at higher temperature. The outcome of this study highlights the good potential of the material to act as a fire resistance or thermal resistance material.

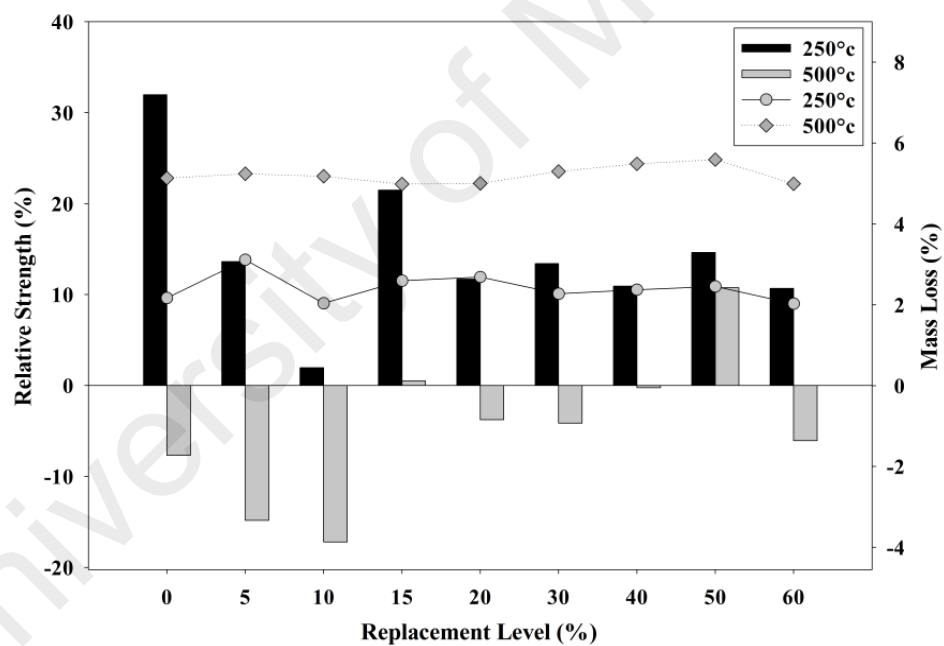

Figure 5.24: Relative strength and mass loss for POC powder samples subjected to elevated temperature

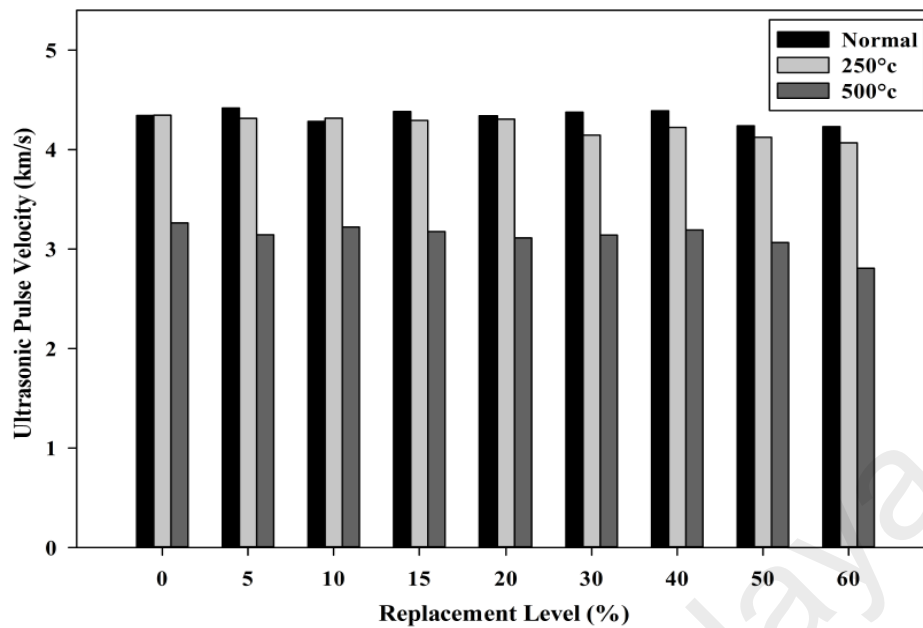

Figure 5.25: UPV for POC powder samples subjected to elevated temperature

5.4 POC Fine SCM

POC fine substitution study was conducted to understand the effect of POC fine only on the fresh, engineering, durability and sustainability properties of the mortar produced. As the feasibility studies reported earlier showed positive findings, there is a huge potential in using POC fine as a sand replacement material. As the natural sand availability is on depletion lately, it would be an innovative and productive idea to utilise POC fine for mass production. SCM was specifically chosen to ensure the results are indicative of only POC fine incorporation without any involvement of POC coarse. This will ensure a complete study carried out on POC fine and the results are reflective of the capability and potential of the material.

5.4.1 Fresh Properties

Table 5.4 tabulates the mix proportion for POC fine used in this study. Figure 5.26 shows the slump flow values of POC fine SCM. As the replacement level rises, the slump flow trend seems to be within the target slump diameter of between 240 to 300mm. As the POC fine replacement level increased, the slump flow increased

concurrently. The less dense POC fine relative to sand lowers the density of the POC mix to enhance the fresh SCM flow to produce a larger spread. This is in agreement with a study performed by Kim et al. (2010) who found that mix with a lower density produced a larger diameter spread. The mix design was specifically designed to achieve this particular range as it satisfies most of the SCM behaviour of flowability, passing ability and segregation resistance.

Table 5.4 : Mix proportion for POC fine SCM

POC Replacement (%)	POC Fine (kg/L)	Sand (kg/L)	Cement (kg/L)	W/B	S.P. (%)
0.0	-	1.14			
12.5	0.12	0.91			
25.0	0.23	0.86			
37.5	0.35	0.72			
50.0	0.46	0.57	0.90	0.30	0.60
67.5	0.63	0.37			
75.0	0.70	0.29			
87.5	0.81	0.14			
100.0	0.93	-			

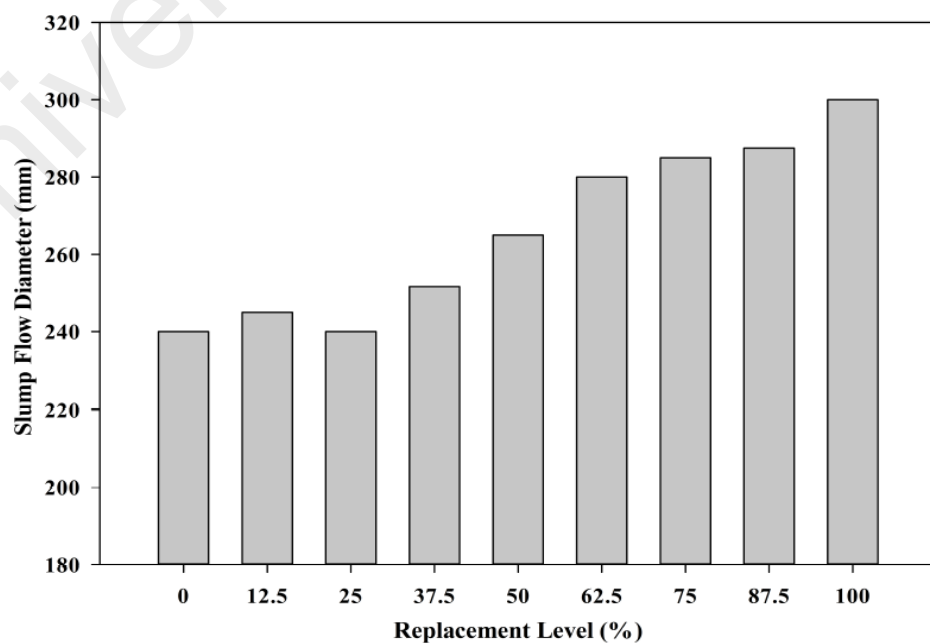

Figure 5.26: Slump flow values of POC fine SCM

5.4.2 Density

Figure 5.27 shows the effect of POC fine replacement on the density of POC fine mortar. The specific gravity of POC fine is 18% much lower compared to ordinary sand (as reported in Table 4.3). There is a reduction of about 6.52% in the density of the mortar when sand is totally replaced with POC fine. This decrease may be much more prominent when POC fine is used to replace sand in POC SCC. The presence of air voids within the POC fine aggregates reduces the density of the mortar. The density of the mortar plays a vital role in affecting the strength properties of the mortar as the strength retention properties reduces with a decrement in density. It should be noted that at a complete replacement of sand with POC fine, the density of the mortar was still above the lightweight mortar region (2000 kg/m^3).

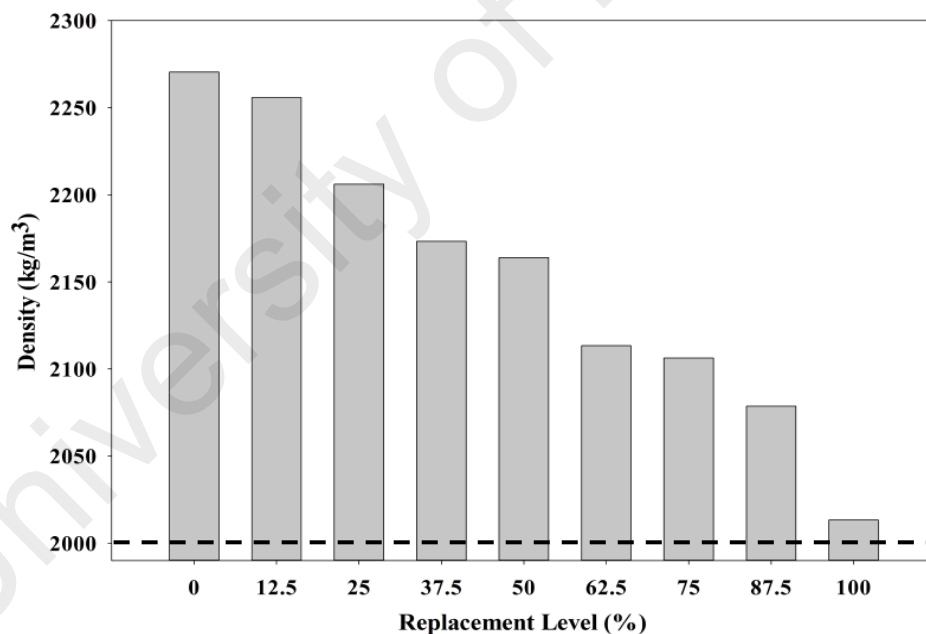

Figure 5.27: Density of POC fine SCM specimens (Horizontal dashed line indicates the boundary of lightweight mortar)

5.4.3 Compressive Strength

Figure 5.28 shows the effect of POC fine addition on mortar strength. As the main objective of this study is to study the feasibility of replacing sand with POC fine, the strength factor is important to evaluate the load bearing capacity of the aggregates in

mortar. As observed from Figure 5.28, the strength properties of the mortar are almost similar when conventional sand is replaced continuously. Almost 8.8% of reduction in strength was observed when sand is completely substituted with POC fine. One of the major reasons behind this would be the reduction in density of the mortar as POC fine is introduced. The lower specific gravity of the materials coupled with lightweight properties may have caused the mortar to fail earlier. In addition, the microstructure of POC fine with higher void content would also affect the maximum strength attaining capability. Meanwhile, a notable increment in strength was observed for POC 12.5% replacement level. This could be due to the good bonding between smaller POC fine content and sand particles. At a lower POC fine replacement, the POC fine particles which have similar particle size distribution might fill up the voids within the sand molecules arrangement to increase the denseness of the mortar to produce greater strength. Above all, the relatively small decrement in strength as compared to conventional sand confirms the capability of POC fine to be utilised in concrete as a fine aggregate replacement material. It would stand as a long term solution to replace sand which is on depletion over the years. Figure 5.29 depicts the relationship between compressive strength and density of the POC fine specimens. A minimum of three 50 mm³ specimens were prepared for this test. As observed, a correlation between them indicates the direct proportional effect of density on strength behaviour of POC fine mortar as mentioned earlier.

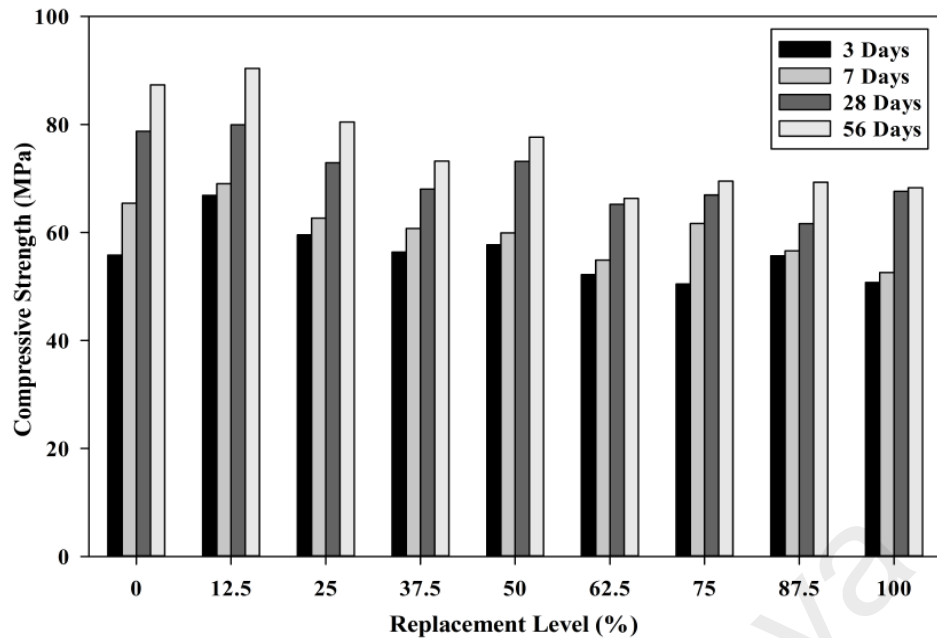

Figure 5.28: Evolution of compressive strength of mortars as a function of POC fine content

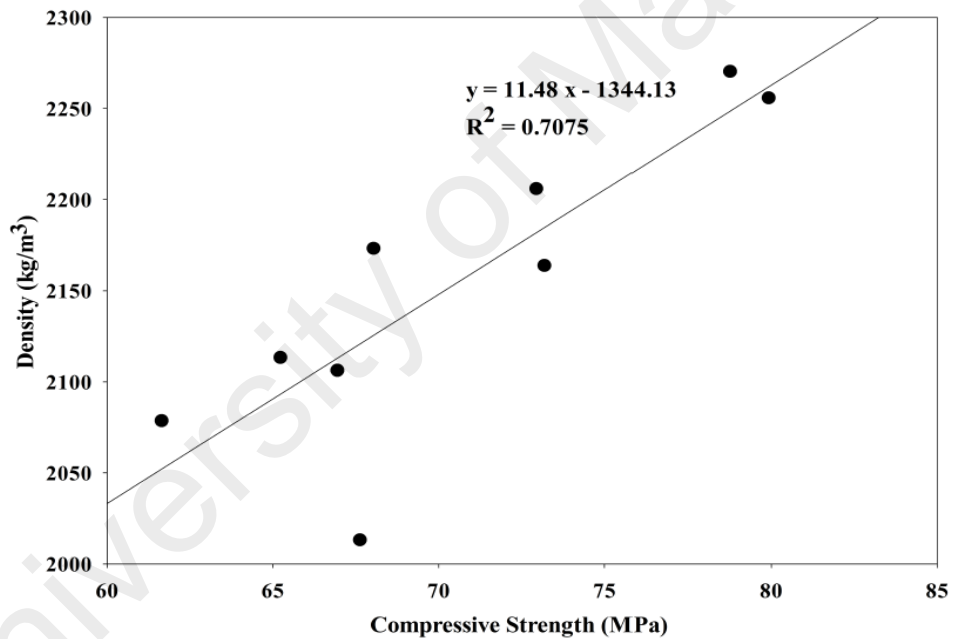

Figure 5.29: Correlation between compressive strength and density for POC fine SCM specimens

5.4.4 Ultrasonic Pulse Velocity (UPV)

UPV values play a vital role to indicate the particle packing of the mortar which provides the rigidity of the mortar or concrete matrix. Figure 5.30 shows the effect of density on compressive strength behaviour. The pulse transfer was observed to have decreased almost sequentially up to 7.25% as the POC replacement level increased to 100%. This can be attributed to the presence of POC fine which is irregular, sharp edges

and with substantial amount of pores. The irregular shape and rough surface of POC may impede the effective pulse transfer across the aggregate and cement paste. Furthermore, the highly porous structure of a POC aggregate with varying void sizes also contributes to lower the pulse transfer rate. The void content within the aggregate which contains air reduces the efficiency of pulse movement across the mortar specimen. (Koksal et al., 2015). This eventually brings down the UPV values for POC fine mortars.

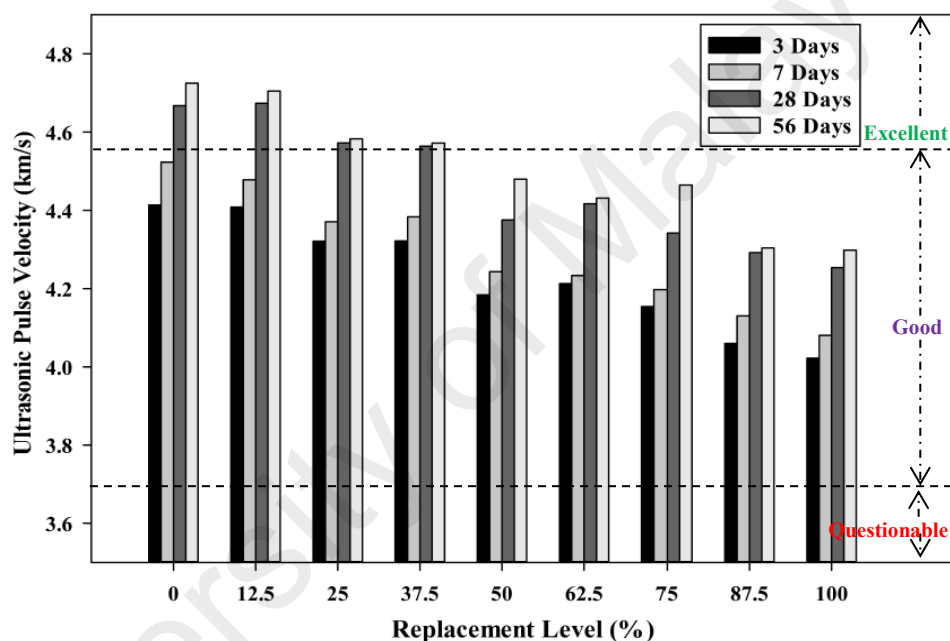

Figure 5.30: Effect of POC fine addition on UPV values for POC fine SCM specimens

5.4.5 Microstructural Properties of POC Fine SCM

POC fine characteristics play a vital role in exhibiting different engineering properties. A microstructural study is important to study the effect of physical characteristics of POC to the properties of the mortar. Figure 5.31 depicts the POC fine under 200x magnification in mortar with EDX result. As observed, the diameter of the void on each aggregate is approximately 100 μ m on average for large voids, meanwhile the smaller voids have diameters of between 25 μ m and 50 μ m. A mortar cube might

consist of immense voids in the range of few thousands and this could be much higher for a concrete cube. These voids may have increased the brittleness of the aggregate besides weakening the aggregate structure to produce lower strength mortar (as discussed in Section 5.4.3). Contrary to POC, conventional mixes incorporating sand exhibited a dense and rigid matrix contributed by the solid structure of the sand (as observed in Figure 5.23). Figure 5.32 shows the substantial amount of voids that are present on POC fine aggregates in mortar. Pyrolysis process that takes place at high temperature may significantly contribute to the higher void formation in POC. This will eventually lower the density of the concrete or mortar block. Similarly, these empty voids may create a poor bonding within the aggregates and paste region to create a lower strength mortar. Figure 5.33 depicts the POC fine-cement paste interface viewed through SEM images. The lower part of the image shows the cement paste while the upper region depicts the POC aggregate. As observed, the cement paste surrounding the irregular and rough POC aggregate produced a good mechanical interlock to induce bonding which helped to provide greater strength properties. This would provide a greater load transfer mechanism to produce greater strength achievement in early ages (Lo et al., 2016).

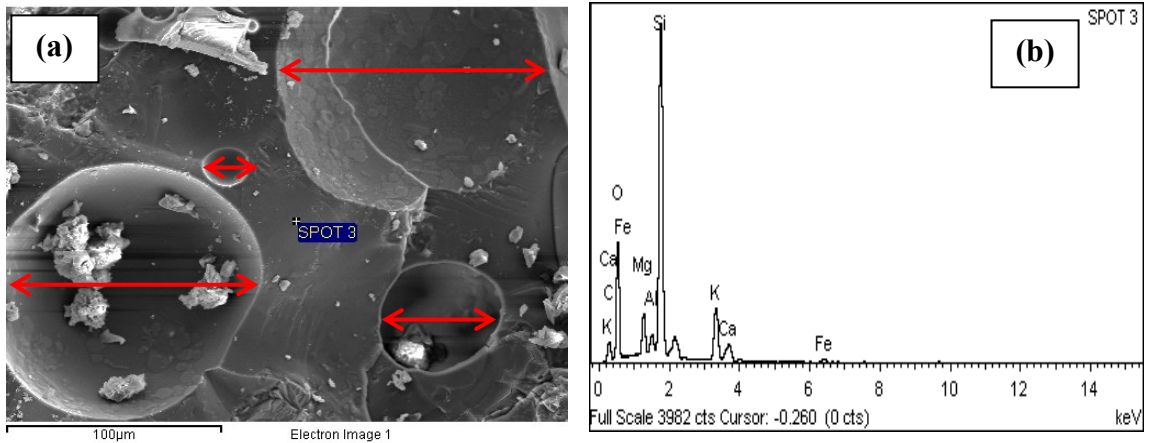

Figure 5.31: (a) Microstructural properties of POC fine (POC 100) and (b) EDX of Spot 3



Figure 5.32: Presence of substantial amount of voids on POC fine aggregates in mortar (as indicated by the red arrows)

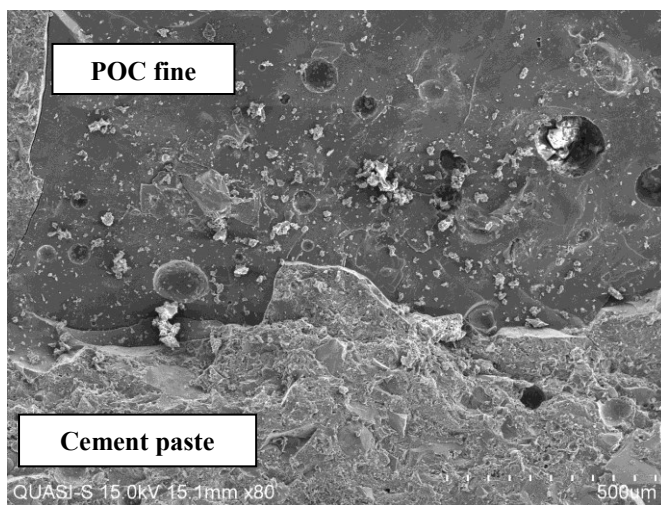

Figure 5.33: POC fine-cement paste interface

5.5 POC Self-Compacting Concrete (SCC) Properties

As discussed in the previous chapters (section 5.1 – 5.4), all the studies carried out converges towards the excellent applicability of POC fine and POC powder in place of sand and cement, respectively for the production of SCC. In this chapter, SCC incorporating POC were further assessed using PP mix proportion method. Their fresh and hardened properties were evaluated thoroughly to investigate the effects of substituting POC in concrete. The long term behaviour of POC SCC was analysed to check the durability performance of the concrete against different external regimes.

5.5.1 POC SCC Mix Proportion

This study introduces a new method of mix proportioning for SCC using PP method alternative to conventionally available mix design. This method of design is expected to ease the process of designing and achieving SCC not only for the researchers but also for an ordinary technician working in the construction industry. Figure 5.34 and Figure 5.35 shows the effect of POC replacement on the particle packing for 0.6 F/A and 0.5 F/A mixes respectively. As observed from the figure below, the PP values decrease with gradual increment of POC aggregates. POC which is of irregular shape with significant amount of voids create empty space when are combined in concrete. Besides that, the nature of POC is which highly porous also greatly contributes towards an increase in the PP values. The large and micro pores on the aggregates need extra paste or binder to coat to enhance the self-compactability of the mixture. Generally, combination of naturally occurring aggregates (gravel and sand) produced high packing level which may be due to the good surface finishing of the aggregates. The vertical shaft impact (VSI) gravel which was obtained from the quarry was of good surface finish with mostly round edges. This increases the possibility of forming highly packed concrete structure compared to flaky aggregates.

Moreover, as discussed in Chapter 3, PP mix design method was introduced in this study to compensate the amount of void on and within the POC particles besides providing sufficient lubrication between the aggregates. The highly porous POC aggregates and poorly packed region due to POC aggregate shape increase the need for extra amount of paste to provide sufficient flow ability and passing ability. Hence, availability of powder materials has to be enhanced to elevate the self-compacting behaviour of the concrete. POC powder was introduced for this purpose to compensate the increasing void content when POC particles are included. All the mixes were subjected to PP studies to optimize the real packing level to enhance the fresh SCC, hardened SCC and durability properties. Table 5.5 and Table 5.6 tabulate the mix proportions for 0.6 F/A and 0.5 F/A, respectively.

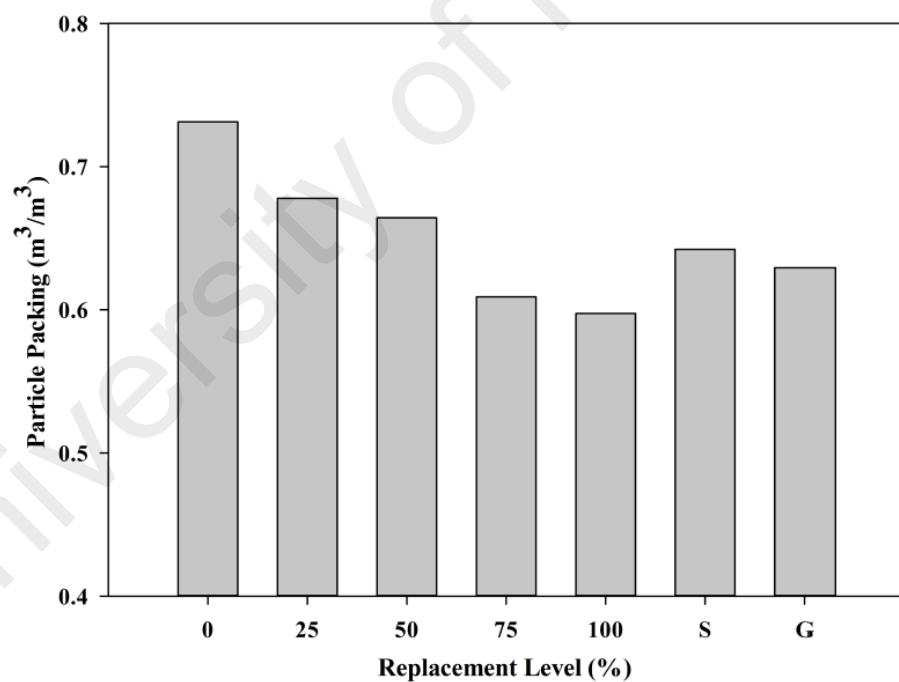

Figure 5.34: Particle packing for 0.6 F/A mixes

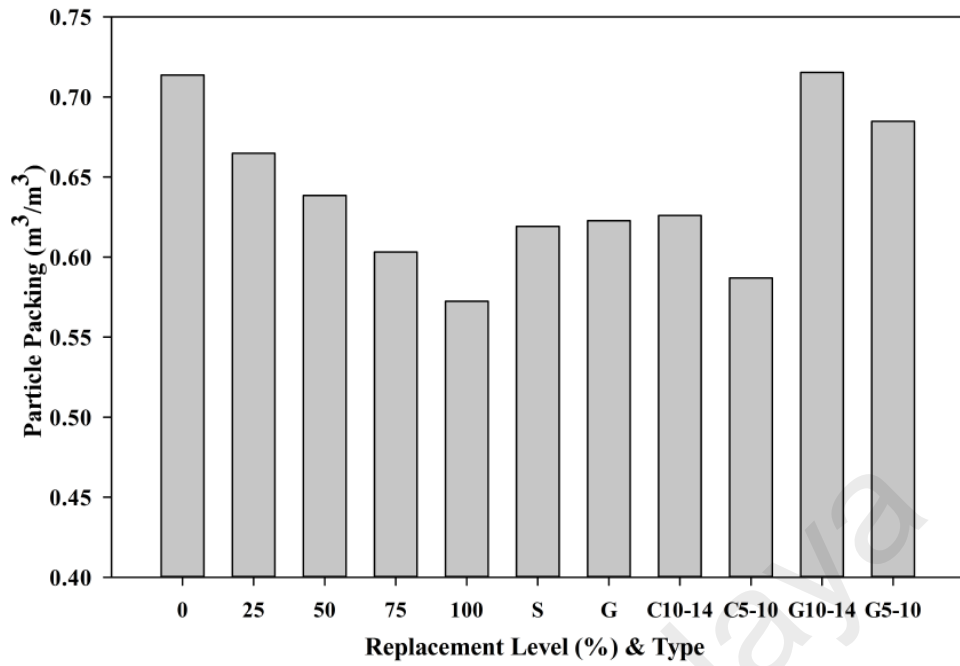

Figure 5.35: Particle packing for 0.5 F/A mixes

Table 5.5: Mix proportion for 0.6 F/A

Mix	POC C (kg/m ³)	POC F (kg/m ³)	Sand (kg/m ³)	Gravel (kg/m ³)	Cement (kg/m ³)	POC Powder (kg/m ³)	Water (kg/m ³)	SP (%)
POC 0	-	-	941	640	420	194	172	
POC 25	97	179	654	445	420	259	190	
POC 50	190	350	427	290	420	276	195	0.45
POC 75	261	482	196	133	420	343	214	-
POC 100	341	630	-	-	420	357	218	0.85
POC S	367	-	827	-	420	302	202	
POC G	-	664	-	550	420	318	207	

*POC 100 – 100% replacement of POC aggregates

*POC S - Replacement of gravel with POC coarse only

*POC G - Replacement of sand with POC fine only

Table 5.6: Mix proportion for 0.5 F/A

Mix	POC C (kg/m ³)	POC F (kg/m ³)	Sand (kg/m ³)	Gravel (kg/m ³)	Cement (kg/m ³)	POC Powder (kg/m ³)	Water (kg/m ³)	SP (%)
POC 0	-	-	765	780	420	215	178	
POC 25	119	146	535	545	420	275	196	
POC 50	228	281	342	349	420	305	204	
POC 75	323	397	162	165	420	350	216	
POC 100	409	503	-	-	420	388	226	
POC S	442	-	664	-	420	331	210	0.4
POC G	-	547	-	681	420	326	209	-
POC C (10-14)	444	-	671	-	420	322	208	0.6
POC C (5-10)	453	-	629	-	420	370	221	
POC G (10-14)	-	-	767	776	420	213	177	
POC G (5-10)	-	-	735	746	420	250	188	

*POC 100 – 100% replacement of POC aggregates

*POC S - Replacement of gravel with POC coarse only

*POC G - Replacement of sand with POC fine only

*POC G (10-14) - Replacement of sand with POC fine only with 10-14mm coarse aggregate size

5.5.2 Fresh SCC Properties Test

The first stage of the research was to establish the right proportion of materials that would provide the optimal and good performance in terms of SCC behaviour. Trial mixes were designed and carried out to determine the correcting lubrication factor (CLF) values, cement content, superplasticizer (SP) content, W/B and F/A ratio. Since the variation of cement content and W/B ratio are determined first throughout the study, the PP values were altered using a CLF constant. Figure 5.36 shows the properties of SCC for various types of application (Walraven, 2003). In this study, the target SCC criteria were carefully selected whereby a generalized category suitable for use in most

of construction applications was preferred. In this study the fresh SCC state was kept in class 2 in accordance to EFNARC (2005) to satisfy slump flow range between 650mm to 740mm; V-funnel range 7s-20s; T_{500} between 2s and 5s; segregation resistance class segregation resistance (SR) 3. This class was specifically chosen as it stands as an average for all the fresh properties class and it would satisfy most of the industrial application. Five different parameters mentioned earlier were checked to arrive at the right proportion of mix to produce a stable mix. All of them have equal importance considering the fact that all of them greatly affect the hardened properties behaviour of the concrete. Trial tests were performed on the most minimum and maximum replacement level to ensure that the boundary of the fresh properties meets the SCC criteria. As the PP values of other combinations were situated within these boundaries, the fresh properties are also expected to be within this range. Trials were only performed on the extreme replacement ratios of POC 100 and POC 0 considering the extreme PP values for these two mixtures.

Viscosity				Segregation resistance/ passing ability
VS 2 VF 2	Ramps			Specify passing ability for SF1& 2
VS 1 or 2 VF 1 or 2 or a target value.		Walls and piles 	Tall and slender	Specify SR for SF 3
VS 1 VF 1	Floors and slabs			Specify SR for SF 2 & 3
	SF 1	SF 2	SF 3	
	Slump-flow			

Figure 5.36: Properties of SCC for various types of application based on Walraven (2003) (Adapted from EFNARC (2005))(Red mark indicates the selected region)

The CLF values were checked and determined in prior to selecting the right dosage of SP, cement content, W/B ratio and F/A ratio. The obtained PP values were directly incorporated into the mix proportion initially to evaluate the possibility of having any self-compactability properties. Fresh tests were only performed on POC 0 and POC 100 mixes taking into account the maximum and minimum PP values respectively. Figure 5.37 depicts the effect of CLF values on slump flow diameter. The dashed lines indicate the required slump flow range. V-funnel flow time and T_{500} time for varying CLF values are presented in Figure 5.38. The dashed lines indicate the required flow time. As predicted, the concrete did not produce any flow and remained stiff. This concrete can be classified as 'conventional' concrete mix and may be useful for conventional concrete casting. In view of this, CLF values 0.95, 0.90, 0.85, 0.825 and 0.80 were introduced. As observed, increasing paste volume as the CLF values reduced produced higher slump flow values. This confirms that an increase in paste volume provides greater slump flow values due to the excess paste effect as provided by CLF values whereby it supports well the main concept of the study on enhancement in lubrication properties. Similar finding was reported by Girish et al. (2010) in which the slump diameter increased at different water content when the paste volume increased. A reduction in aggregate content with respect to overall concrete volume through CLF increases the tendency of the concrete to flow under substantial amount of paste content. Although high paste volume is more susceptible to segregation, introduction of POC powder managed to eliminate this problem. The high water absorption of POC powder reduces the availability of excess water leading towards segregation problems. CLF values of 0.95, 0.90, 0.85 and 0.80 produced slump values which are not within the required SF 2 range. Hence, CLF of 0.825 was selected as it gave the right self-compactability between passing, flow and segregation resistance. Although Rizwan and Bier (2012) stressed that particle shape have pronounced effect on the flow parameter,

introduction of CLF values increased the deformability of the concrete through effective coating and sufficient paste content to increase its performance against self-compactability criteria. From another point of view, as the ordinary paste volume obtained from the PP method does not cater for flow ability and passing ability aspect, the elevation provided an additional suspension performance of the aggregates within the concrete. This ensures the aggregates are provided with sufficient coating and a medium of transfer to allow them to migrate easily without any additional vibration.

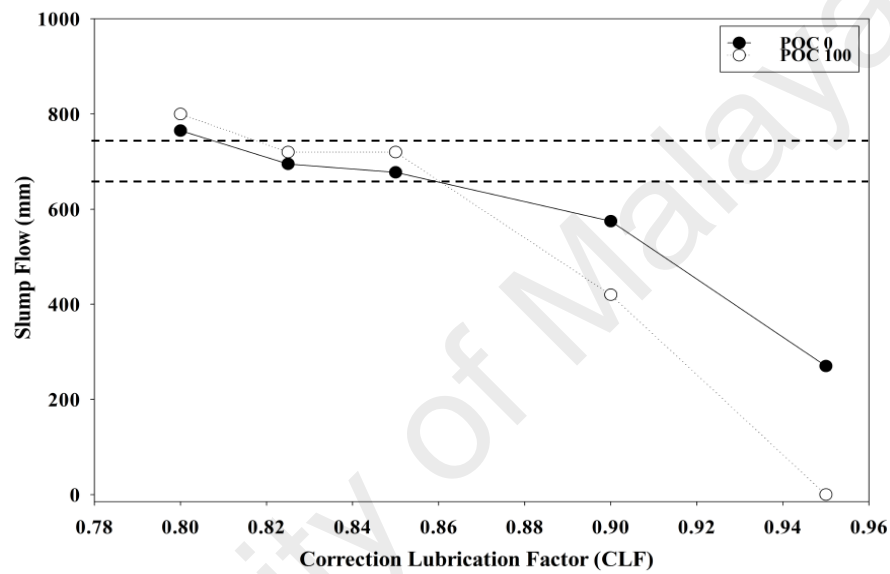

Figure 5.37: Effect of CLF values on slump flow diameter

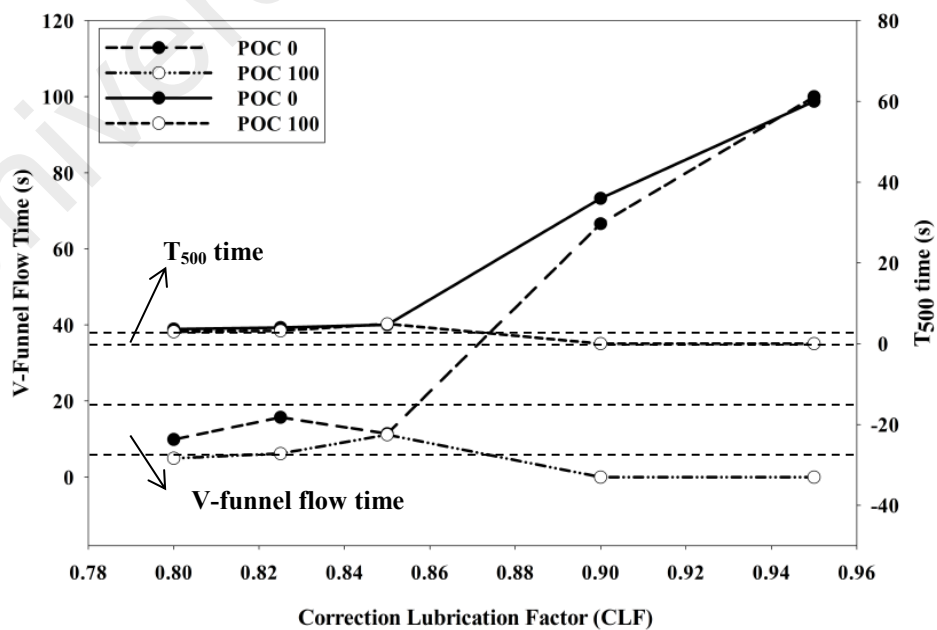

Figure 5.38: Effect of CLF values on V-funnel flow time

The cement content was determined by taking into consideration the GHG emission and cost of cement. Three different cement contents (380 kg/m^3 , 400 kg/m^3 , 420 kg/m^3) which are lower than 500 kg/m^3 were selected randomly to determine the fresh properties of the concrete. Based on the trial mix performed, it is evident that at lower cement content, presence of higher POC powder content showed non-conformity to the self-compacting range. This may be due the higher dilution effect contributed by the availability of higher POC powder. Although all the cement replacement levels showed good self-compactability properties, higher cement content was preferred considering the need for greater POC powder inclusion. This is important to maintain the stability of the mix with the presence of substantial cementitious material as compared to POC powder which may act only as a filler with weak pozzolanicity.

S.P dosage plays a vital role in achieving the right self-compactability of the fresh concrete state. As the PP values were different for each level of replacement, the use of similar S.P dosage throughout the study was not possible due to the SCC class conformity. Thus, few trial mixes were performed for each mix containing different proportion of POC to arrive at the right dosage. This process was further shortened as the range for maximum S.P dosage for POC 0 and POC 100 helped to set up a range that would be suitable for other mixes. This was possible as the PP values of all other mix combination were within POC 0 and POC 100. It is noted that a direct relationship between S.P dosage and fresh properties exists. The higher PP value for POC 0 mix required greater S.P dosage in comparison to lower PP value of POC 100. The mixes in between them i.e POC 25, POC 50 and POC 75 followed the similar pattern confirming to this relationship. Greater S.P dosage was required for higher PP mix considering the stiffness and lower paste content of the mix. Paste workability tends to increase as higher dosage of S.P is incorporated as a result of greater surface and dispersion properties creation (Heikal et al., 2013). Addition of S.P tends to create negative

charges on the cement particles to create an opposite forces among them. In addition, the lubrication of the mix improves as a result of the hindrance properties which increases the distance between particles. These properties will further influence when the S.P (polycarboxylate) dosage is increased (Heikal et al., 2004).

W/B ratio selection required a very careful analysis as the fresh properties, rheological properties and hardened properties of SCC would be affected. Although the objective of the study is not to produce SCC with high strength properties, a minimum strength that would be feasible for use in ordinary concrete structures and structural elements was made to be a priority. Three different W/B ratios were selected (0.28, 0.30, 0.32) in this study to arrive at the right balance between fresh and hardened properties. As expected higher W/B ratio satisfied POC 0 but not for POC 100 as the higher water content increased further the dilution effect. Besides that, higher paste volume content for POC 100 mix further influenced the selection to have a lower W/B ratio to avoid segregation. Hence, a lower W/B ratio (0.28) was selected to accommodate both the higher and lower extremes.

Ratio of fine aggregate over the total aggregate content (F/A) require a proper selection to ensure the right self-compactability is achieved. Three different F/A ratio (0.4 F/A, 0.5 F/A, 0.6 F/A) were tested to check the right proportion of mix design considering the effect of POC addition. Based on PP values tested, 0.4 F/A gave a very high void ratio for POC mixes which makes it not suitable. The possibility of segregation is high due to the higher amount of paste volume required. This increases the need to use a viscosity modifying admixture (VMA) to control the segregation which incurs an increase in cost of the concrete. Thus, 0.5 F/A and 0.6 F/A were selected as they best fits both extreme levels of POC 0 and POC 100. Besides contribution by the mix design proportion and CLF, the aggregates appearance and

density also play a vital role in exhibiting different fresh properties results. As described earlier, POC aggregates are lightweight, porous, irregular shape and contains huge amount of pores on the surface. These characteristics play an important role to influence the transport properties of the aggregates when subjected to suspension. In addition, the pores within POC aggregates is about $200\mu\text{m}$ and it should be taken into account as the severe paste reduction can lead to poor fresh properties. Thus, by considering these characteristics, a different mixing approach was implemented. A section of mixing procedure was dedicated to coat the aggregates with the available powder materials. This process reduces the voids that are present within the aggregates to enhance the flow properties.

5.5.2.1 Slump flow

The slump flow is a measurement of the flowability of the SCC mixture. Yield stress within the concrete plays a vital role to exhibit different flow properties. Flowability of SCC is affected by all the factors investigated in this research especially paste content, W/B ratio, superplasticizer dosage and aggregate ratio. Figure 5.39 and Figure 5.40 shows the slump flow values for 0.6 F/A and 0.5 F/A mixes experimented in this research, respectively. As observed, they were made sure to satisfy the ‘mid-range’ of SCC (660mm- 750mm) to maximize its application in other fields. This class was specifically chosen taking into consideration the applicability of the concrete in various locations as proposed by EFNARC (2005). Trials were conducted to ensure the concrete meets the requirements stipulated by the standard. Figure 5.41 depicts the effect of paste volume on the slump flow values. Lower PP values for higher replacement levels (POC 50, POC 75 and POC 100) produced greater slump flow values. The reduced stress within the aggregates for increasing POC replacement showed greater slump flow diameter but within the stipulated range (SF 2). Previous study also confirm that an increment in paste volume for different water content produced greater slump flow

values (Girish et al., 2010). Furthermore, the reduction in the weight of concrete matrix could also have a notable effect on the slump values. POC which is lighter or having lower density compared to normal aggregates reduces the total weight of the concrete to allow for greater flow properties. As both coarse and fine aggregates of POC are being substituted in place of natural aggregates, the rate of reduction is substantially predominant. Previous study shows that, when two lightweight aggregates are incorporated in SCC, the lower density aggregates tends to produce greater slump flow diameter compared to the heavier ones (Kim et al., 2010; Topçu & Uygunoğlu, 2010). This indicates that the lightweight aggregates have a greater momentum to move forward compared to the conventional aggregates.

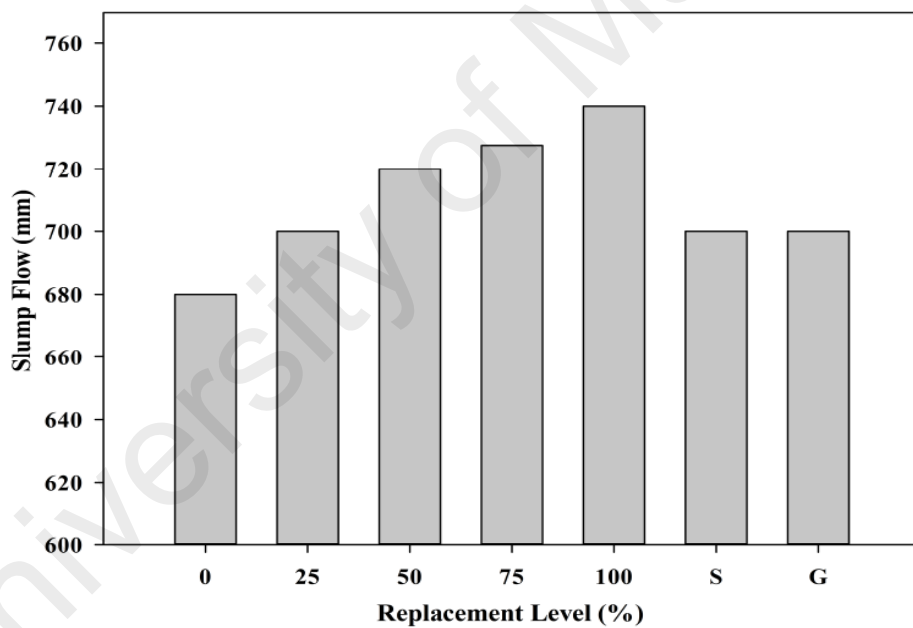

Figure 5.39: Slump flow values for 0.6 F/A POC SCC

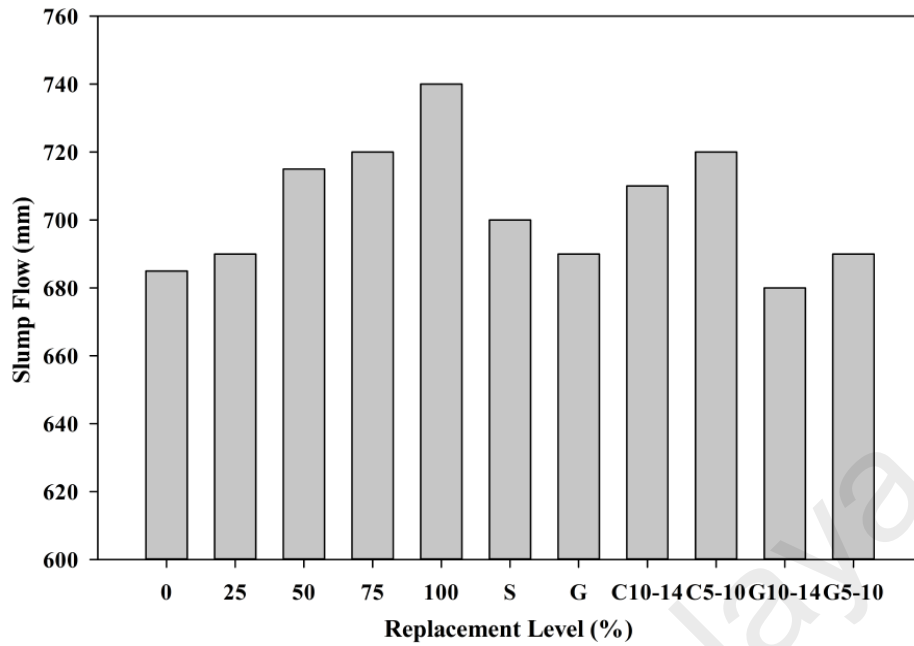

Figure 5.40: Slump flow values for 0.5 F/A POC SCC

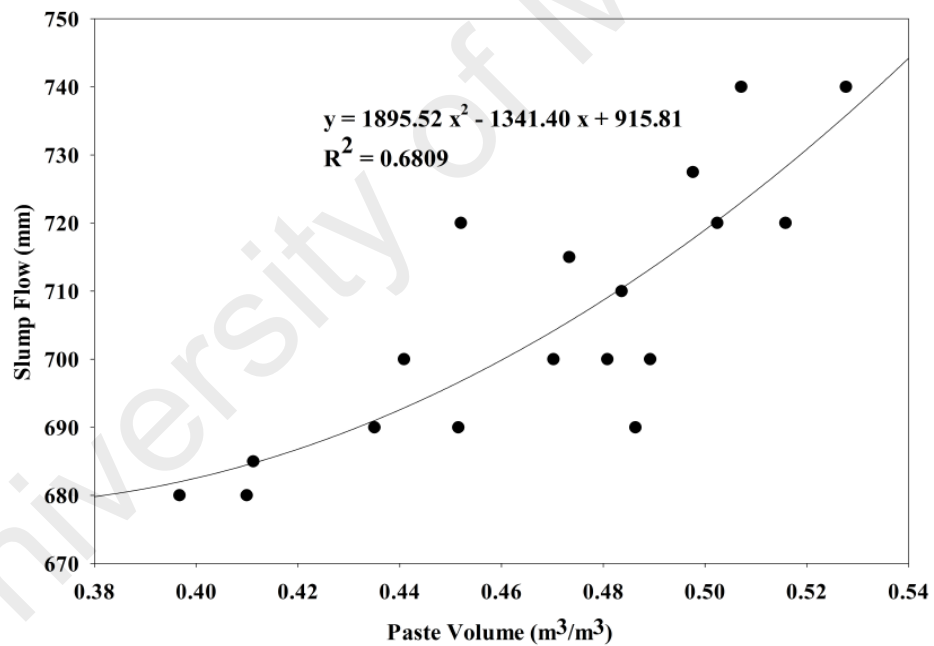

Figure 5.41: Effect of paste volume on the slump flow values of POC SCC

5.5.2.2 V-funnel flow time and T_{500} time

Figure 5.42 illustrates the V-funnel flow time and T_{500} results for 0.6 F/A. Meanwhile, Figure 5.43 shows the V-funnel flow time and T_{500} results for 0.5 F/A. A pronounced effect of POC addition can be observed whereby the V-funnel time

decreased for all the mixes indicating the lowering of the concrete matrix viscosity. Higher paste content for higher replacement level due to greater void content influenced the flow properties to enhance the flow behaviour. Although most of the researchers (Choi et al., 2006; Kim et al., 2010) reported that the V-funnel time increased with increment in lightweight aggregate proportion (coarse and fine), in this study a different trend was observed. Replacement of natural aggregates lowered the flow time of the mix which is due to the PP mix design concept. As the paste volume is also elevated correspondingly with replacement level, the less viscous state of the mix due to good lubrication between aggregates produced shorter flow time. POC 100 which is the lightest or least dense among all the mixes showed fastest flow time as the coating effect helped to alter the surface area of the aggregates to be round and smooth. This enhancement in turn increases the capability of POC aggregates to flow easily and produce better self-compactability. This is also in parallel with findings reported in past studies (Liu, 2010; Sua-iam & Makul, 2014).

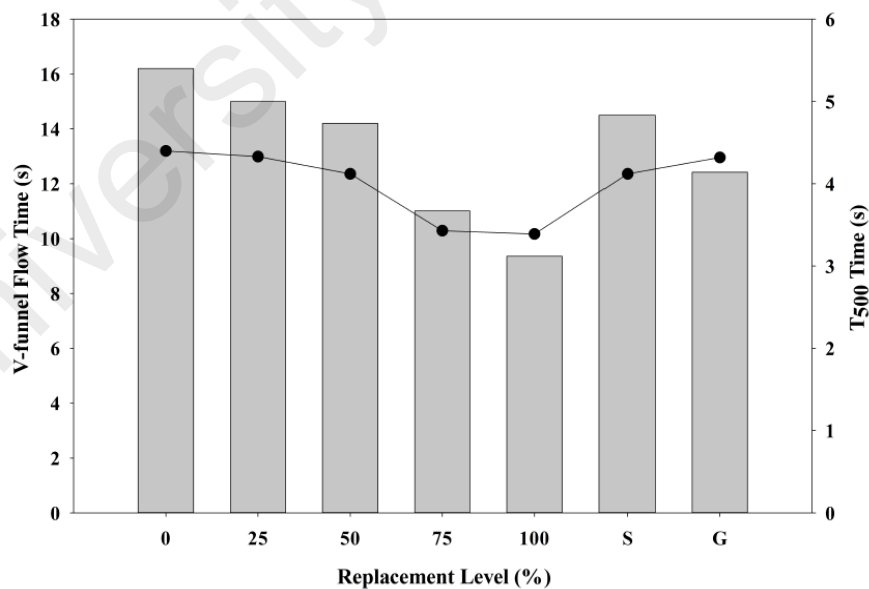

Figure 5.42: V-funnel flow time and T₅₀₀ time for 0.6 F/A POC SCC

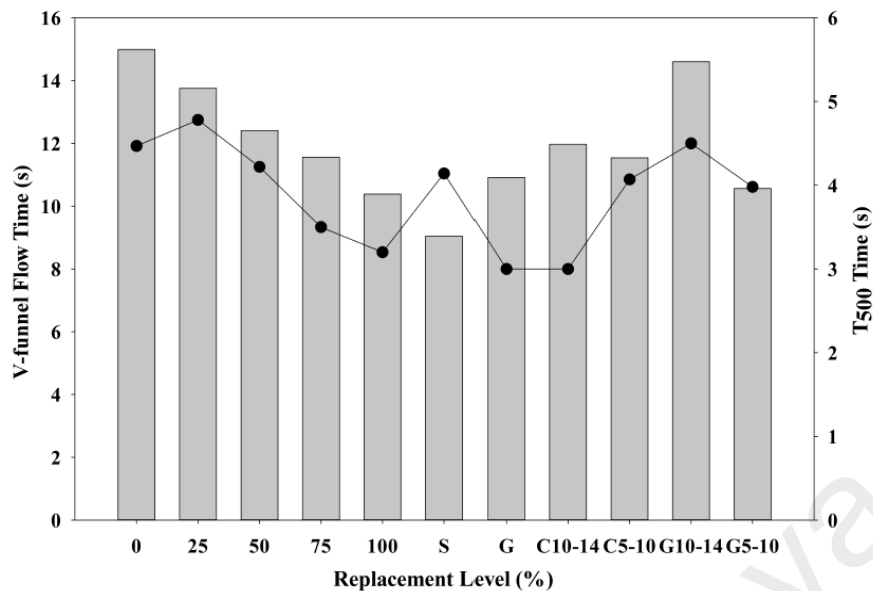

Figure 5.43: V-funnel flow time and T₅₀₀ time for 0.5 F/A POC SCC

Moreover, the larger size of aggregates (10mm-14mm) also has a predominant effect on the flowability of concrete. As observed the larger size of aggregates showed longer flow time for both POC and natural aggregates. This may be due to the greater aggregate volume within the concrete matrix as a result of higher PP values. Lower lubrication effects between aggregates increases the tendency of the mix to be stiffer and required greater yield stress for deformability. However, for POC mixture, the effect was rather small as the density of POC aggregates was lower and not significant.

5.5.2.3 Segregation resistance test

Segregation resistance is vital to ensure the stability of the SCC mix against segregation which would significantly affect the hardened and durability features of the concrete. Figure 5.44 and Figure 5.45 shows the sieve segregation resistance test results for 0.6 F/A and 0.5 F/A, respectively. All the mixes produced a segregation resistance percentage lower than 15%, thus satisfying the maximum range stipulated by EFNARC (2005). As predicted, higher paste volume content for high replacement of POC, produced greater percentage of segregation. However, this enhancement made through

PP method did not adversely affect the stability of the mix to cause segregation. Despite the need to increase the paste volume to substantiate the paste loss due to the special characteristics of POC aggregates, the segregation values still fell on limits indicating the suitability of CLF application. However, it should be noted that on average 0.5 F/A mixes showed greater segregation resistance percentage compared to 0.6 F/A mixes which is due to the higher paste volume content within the mixture.

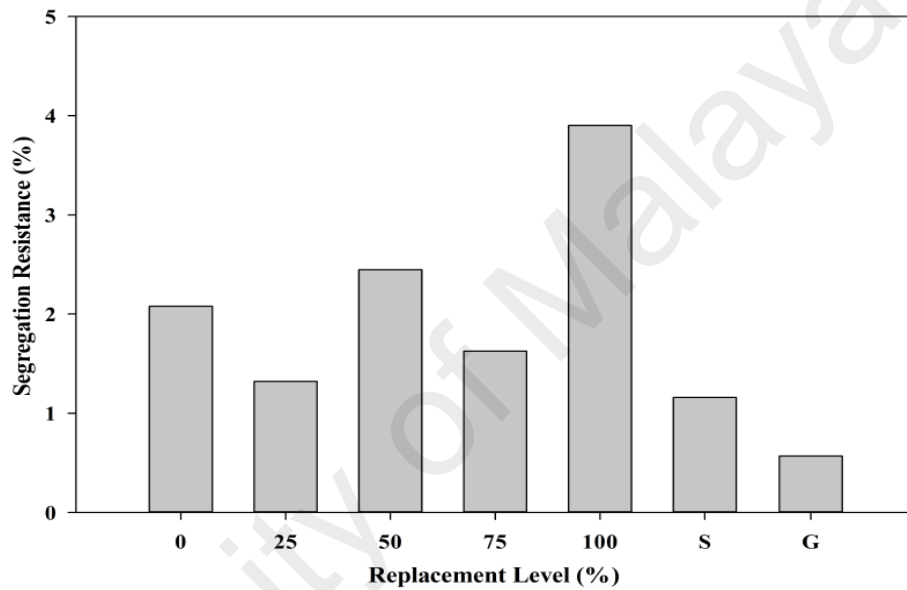

Figure 5.44: Segregation resistance (0.6 F/A)

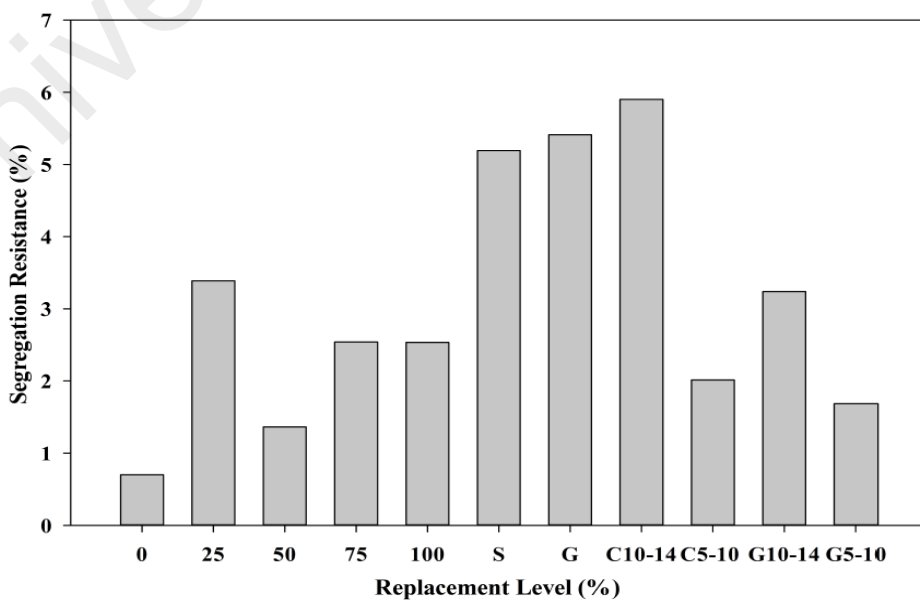

Figure 5.45: Segregation resistance (0.5 F/A)

5.5.2.4 L-box test

The passing ability of the concrete can be established through L-box test. Besides that, the highly flow able mix created with the introduction of CLF values helped to increase the passing ability features of SCC. All the mixes (0.5 F/A and 0.6 F/A) in this study produced L-box ratio of one (1) which indirectly indicates the high flowability of the mixes. Although presence of POC aggregates which are porous and irregular in shape expected to reduce the fresh SCC performance, enhancement made to the mix design using PP method helped significantly to coat and provide satisfactory flow properties. This indicates that the mix design is suitable to be used against heavy congested reinforcement to avoid the problems of honeycombs and poor settling properties.

5.5.2.5 Rheological properties of SCC

As the fresh properties test using slump flow, V-funnel and L-box generally are still an indirect measurement of self-compactability, rheological properties provides direct values to quantify the flow behaviour. In this study, ICAR rheometer was used to analyse the fresh state of the concrete. Figure 5.46 and Figure 5.47 show the correlation between slump flow and yield stress of SCC for 0.6 F/A and 0.5 F/A mixes, respectively. Few studies available in literature also confirmed this correlation (Bartos; Roussel, 2006; Wallevik, 2006). In this study, an increase in POC content tends to reduce the yield stress and plastic viscosity. The yield stress range for POC mixes in this study is between 20 Pa and 125 Pa. Firstly, this is due to the lightweight nature of POC as a result of porous or honeycombed properties. The lower density of POC aggregate tends to reduce the yield stress of the SCC mix as the fresh density of the mix decreases compared to normal aggregate mix. This positively affects the amount of initiating force required to make the SCC flow without the need of external vibration. As the replacement level is reduced, the yield stress level increased substantially due to increasing natural aggregates content. Taking into account the higher paste volume

corresponding to greater void content, the shear stress of the mix is lowered significantly. The inter particle friction is greatly reduced as the paste volume is increased due to lower PP. Sufficient lubrication is provided by this paste content to enhance the flow properties which helps to reduce the stress between the aggregates. This was also reported in literature by (Gesoglu et al., 2015) for lightweight aggregates. In addition to that, addition of POC powder which was also found to be less dense than cement also contributes to lower the yield stress of the mix. The non-cementitious nature of POC powder creates dilution effect to reduce the stress within the mixture. It must be noted that for Bingham yield stress measurement, all the mixes showed values lower than 10 Pa. Gesoglu et al. (2015) mentioned that the Bingham yield stress for SCC are usually very low and may be ignored. In this study, all the yield stress values was lesser than 10 Pa which is in agreement with the study above.

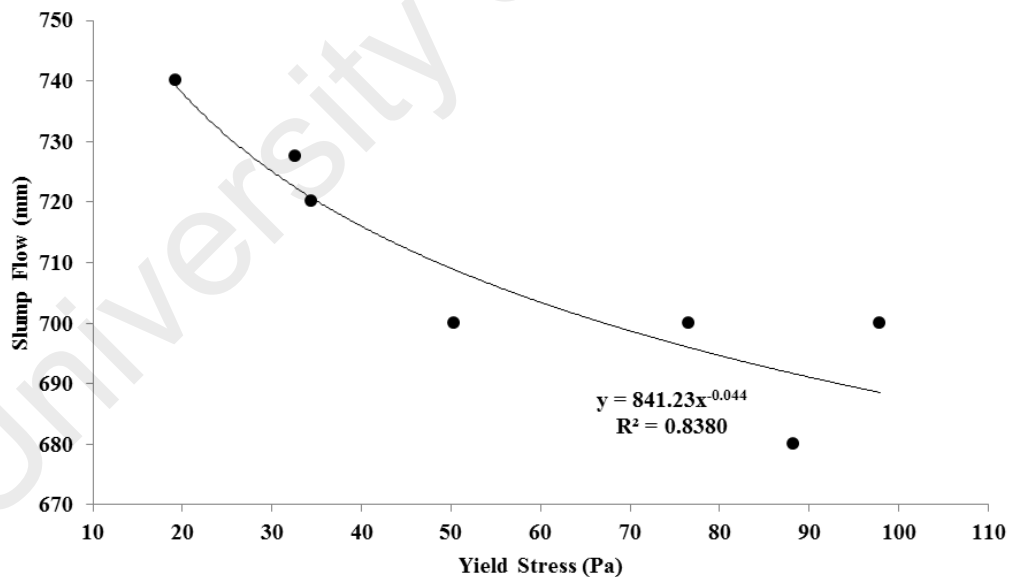

Figure 5.46: Correlation between slump flow and yield stress for 0.6 F/A mixes

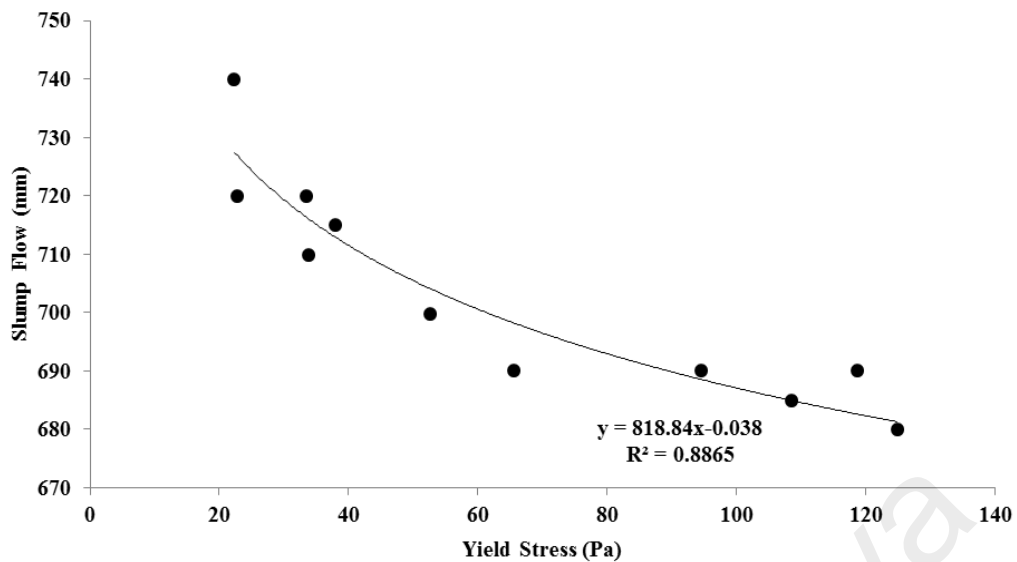

Figure 5.47: Correlation between slump flow and yield stress for 0.5 F/A mixes

Most of the previous studies reported that spherical shape of aggregates and texture of lightweight coarse aggregates (LWCA) and lightweight fine aggregates (LWFA) improve the flow properties of the concrete (Su et al., 2001; Wu et al., 2009; Gesoğlu et al., 2014b). However, in this study despite having POC which is irregular with porous and rough texture, the flow characteristics were enhanced with the introduction of PP mix design method. The optimised paste volume provided to coat and lubricate the particle helps to create the satisfactory flow properties. Besides that, spherical shape aggregates are favoured to ease the flow whereby they require lower cement and water content due to lower surface area (Tattersall, 2003; Quiroga & Fowler, 2004; Gesoğlu et al., 2014b). In this study, the extra paste volume which was required to create excess paste effect was established through the introduction of POC powder. It supplemented a cheaper and sustainable option rather than using additional cement or any other powder materials. Figure 5.48 and Figure 5.49 show the relationship between V-funnel flow time and viscosity for 0.6 F/A and 0.5 F/A, respectively. An increasing paste volume expected to produce lower viscosity which was also verified through V-funnel flow test. The prolonged V-funnel flow time corresponding to greater viscosity was also observed by few other researchers (Chai, 1998; Khayat, 1999). Addition of POC powder in place

of cement increased the dilution effect to reduce the setting properties of the paste. This in turn lowers the viscosity of the mixes. On the other hand, POC 0 with natural aggregates showed greater viscosity corresponding to lower paste content and greater concrete matrix weight.

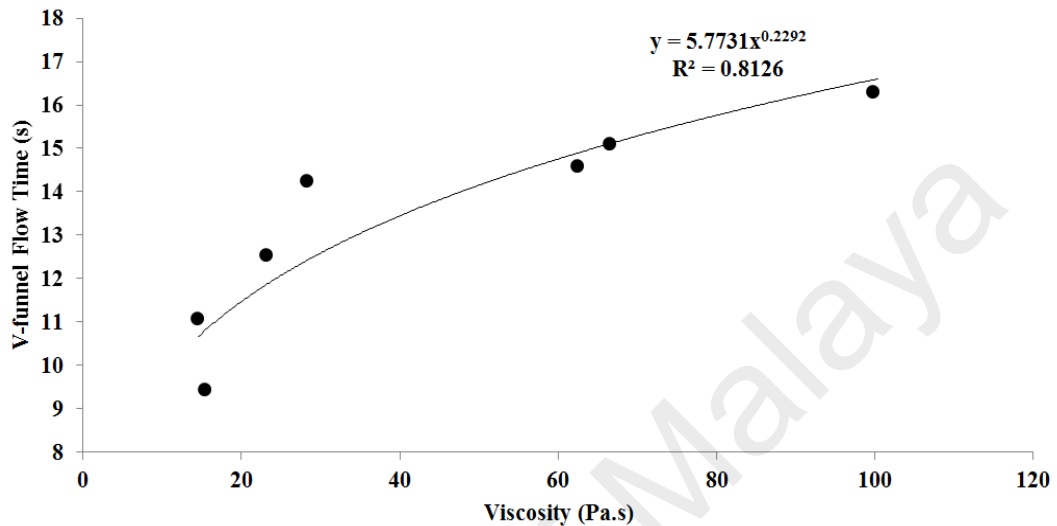

Figure 5.48: Correlation between V-funnel flow time and viscosity for 0.6 F/A mixes

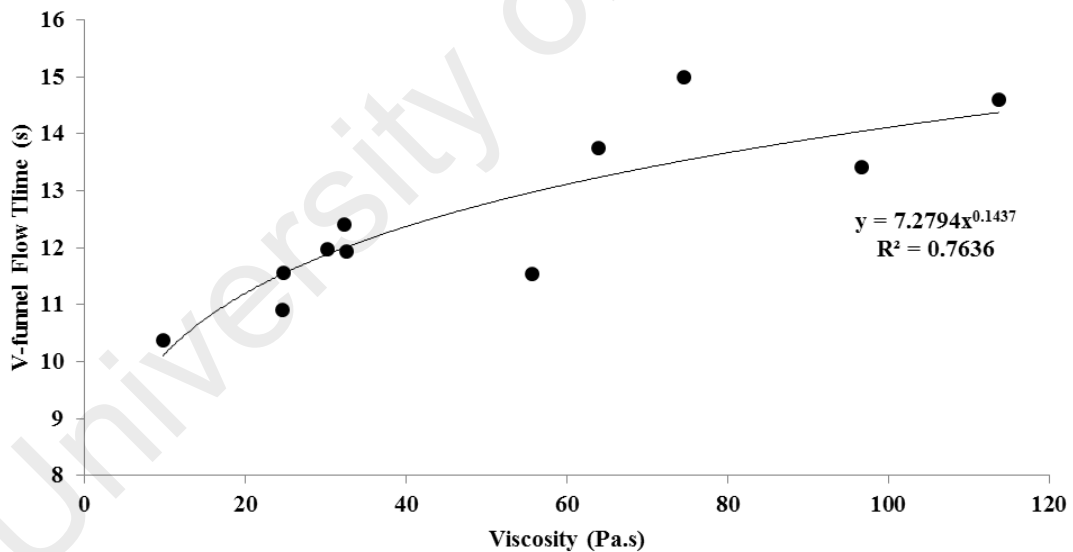

Figure 5.49: Correlation between V-funnel flow time and viscosity for 0.5 F/A mixes

5.5.3 Hardened Properties of POC SCC

In this study, SCC was chosen specifically to create a concrete which is stable from mechanical and durability point of view. Besides that, the output of SCC in terms of its finishing and architectural behaviour also provides an added advantage. In this section,

the hardened properties of SCC incorporating POC will be investigated to understand its changes in behaviour compared to ordinary aggregates.

5.5.3.1 Density

Figure 5.50 and Figure 5.51 show the effect of POC replacement on density of the concrete for 0.6 F/A and 0.5 F/A mixes, respectively. Introduction of POC, a lightweight aggregate due to its lower bulk density reduces the overall mass of the concrete (As observed from Table 4.4 (section 4.2.4)). POC aggregates which are highly porous with significant micropores and macropores as discussed earlier in microstructure characterisation (Section 4.2.2) reduces greatly the mass to volume ratio of the concrete. It should be noted that a POC coarse aggregate generally is 34% lower in mass than that of ordinary gravel, meanwhile POC fine is about 18% lesser in mass compared to river sand. As the replacement level of POC increases gradually, the density of the concrete also reduced concurrently lower than 2000 kg/m^3 at maximum POC substitution. A reduction in density of the concrete of about 18% and 20% was found for F/A 0.6 and F/A 0.5 mixes (POC 100), respectively. However, it should be noted that only POC 100 mix managed to attain the lightweight concrete region (as observed from the Figure 5.50) due to the substantial presence of POC in the form of POC coarse, POC fine and POC powder. Moreover, POC 50, POC S and POC G gave similar density ratio as predicted earlier through the close PP values. Besides that, incorporation of POC powder which can be also considered as a semi lightweight binder material does not contribute significantly to any increment in the density of the mixes.

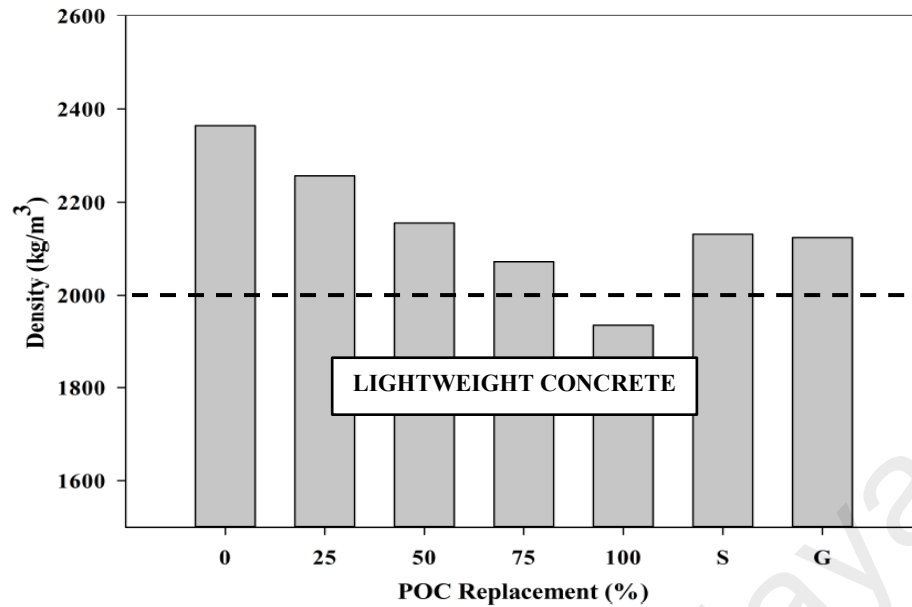

Figure 5.50: Relationship between density and POC replacement (0.6 F/A)

Figure 5.52 depicts the correlation between all the particle packing values and obtained densities. As POC is substituted increasingly, there is a substantial drop in density of the concrete mix. High void content of the POC aggregates significantly brought down the density of the mix. The correlation provided would serve as a good equation to predict the possible density reduction for a given particle packing generally. Accordingly, lower density feature of POC incorporated concrete also greatly affects the load bearing capacity of the concrete due to significant presence of lightweight aggregates content. This would be discussed in-depth in upcoming sections.

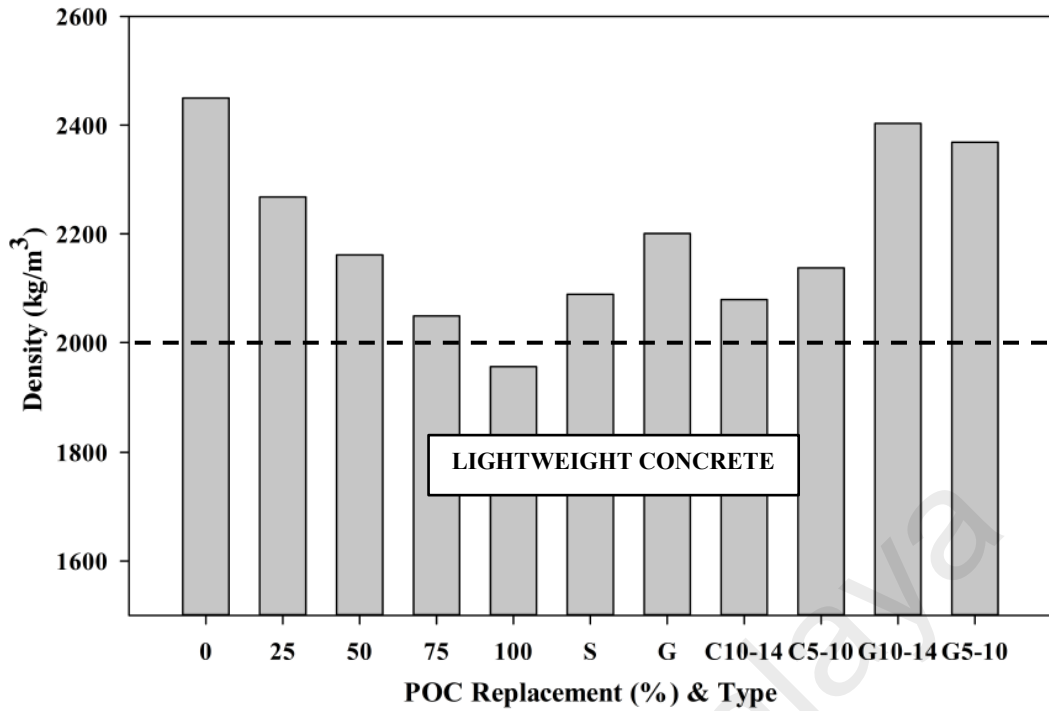

Figure 5.51: Relationship between density and POC replacement (0.5 F/A)

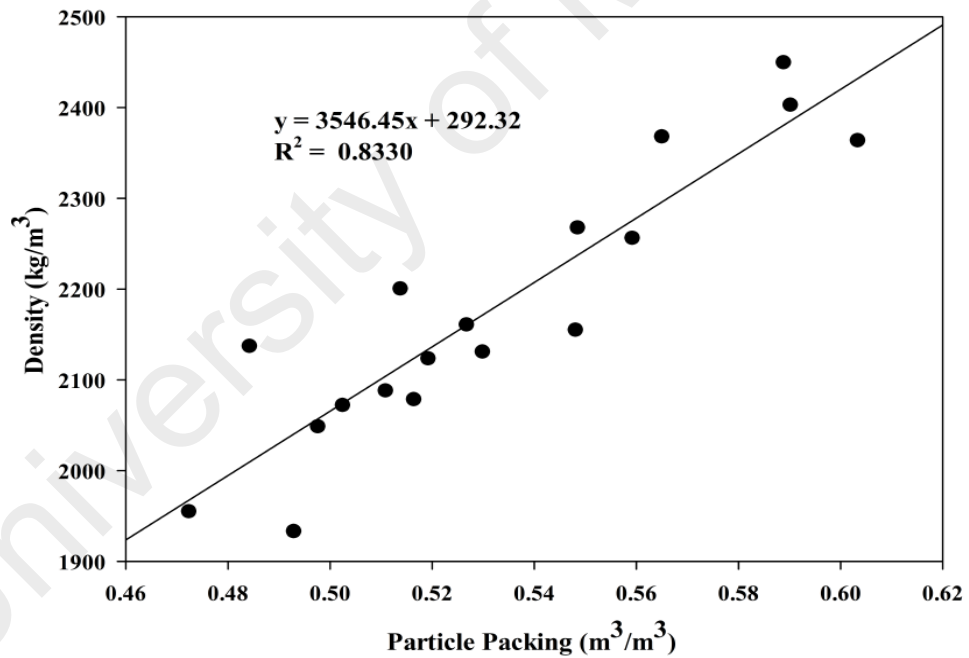

Figure 5.52: Correlation between density and particle packing of all POC mixes

5.5.3.2 Ultrasonic pulse velocity (UPV)

Figure 5.53 and Figure 5.54 shows the relationship between UPV values and POC replacement. Researchers agree that UPV is utilised to relate the strength properties to that of packing or compactness of the concrete mix (Prassianakis & Prassianakis, 2004).

Besides that, Lorenzi et al. (2007) mentioned that UPV wave movement can be also used to study the heterogeneous structure of a concrete. As observed in both figures, POC 100 showed only 18% on average lower UPV values compared to POC 0 for both 0.6 F/A and 0.5 F/A. POC 25, POC S, POC G and POC 50 showed almost similar pulse velocity as depicted by the small variation in packing values. Concrete with larger size of aggregates (10-14mm) either POC aggregate or gravel, showed slightly higher UPV values compared to smaller size of aggregates. This may be due to the higher volume of coarse aggregate compared to cement paste (Ariöz et al., 2009).

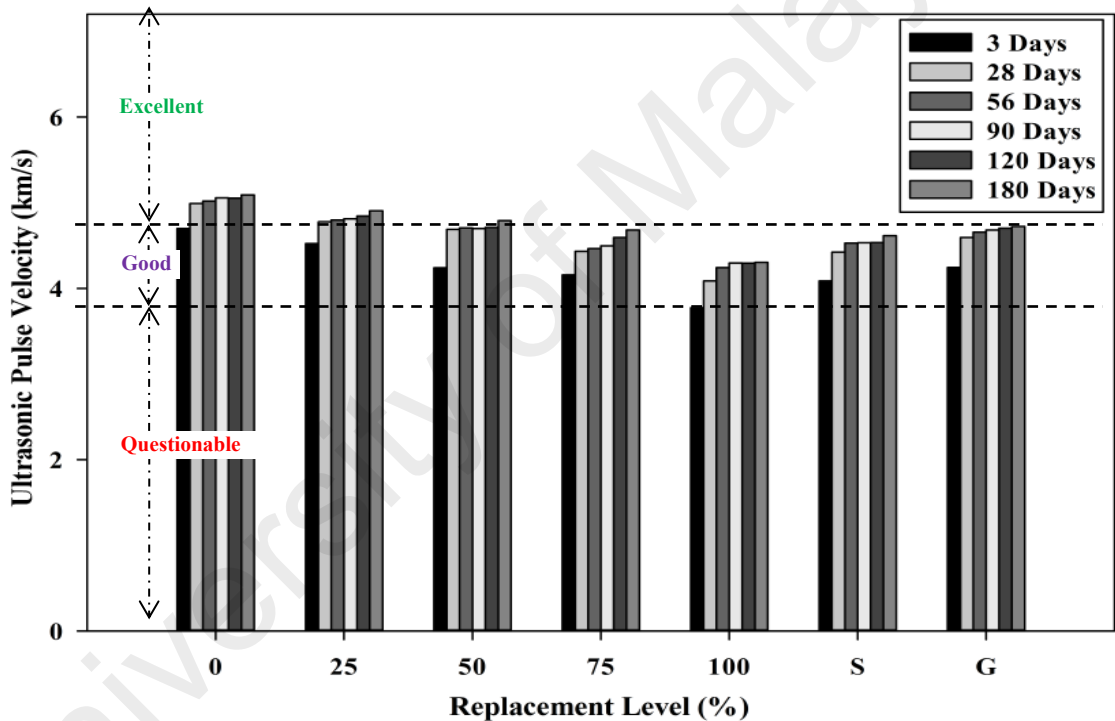

Figure 5.53: Effect of POC replacement on UPV values (0.6 F/A)

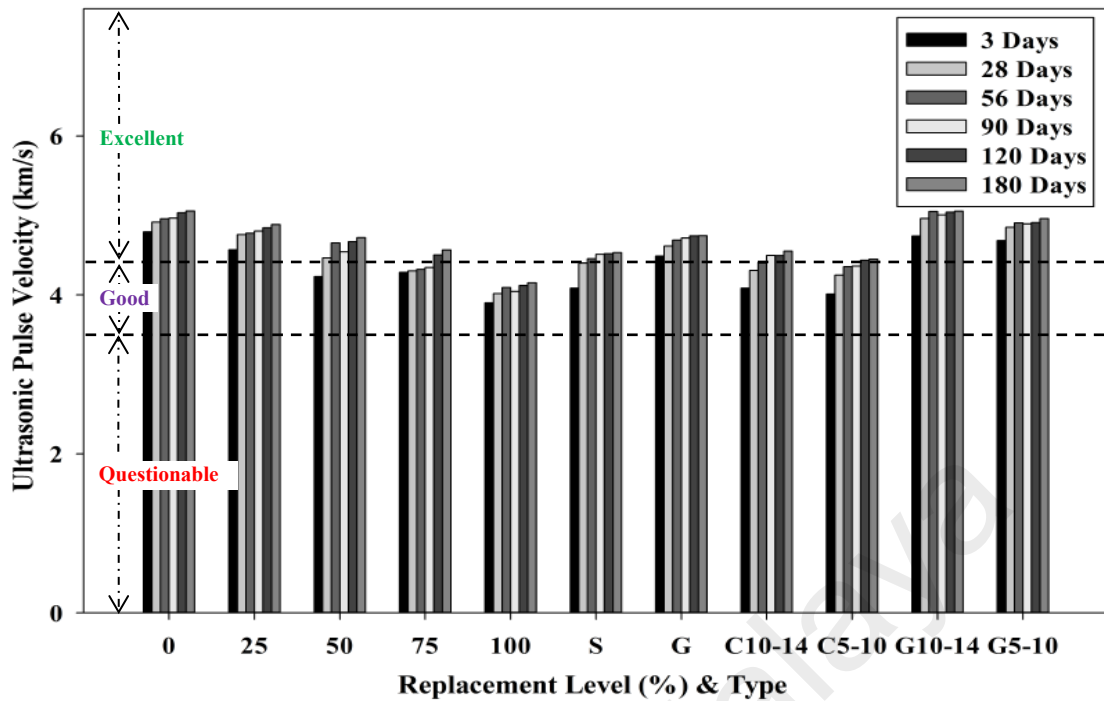

Figure 5.54: Effect of POC replacement on UPV values (0.5 F/A)

Availability of POC which are honeycombed reduces the denseness of the concrete to produce lower pulse readings. An overall observation shows that UPV values for maximum and minimum POC inclusion were well above 4500 m/s at 28 days. Though Hwang et al. (2012) suggested that a ‘good’ concrete would have an UPV values in range between 3650 m/s and 4450 m/s, the attained values in this study were higher indicating superior concrete quality. As the PP method of mix proportioning is mainly implemented in this work, UPV values obtained from hardened state of concrete is vital in this study to predict some of the mechanical properties. The mix design process which involves assessment of PP does provide some impact to the pulse transmission at different POC replacement ratios. It should be noted that the type aggregates characteristics plays a vital role in exhibiting variation in pulse transfer. POC particles which are generally of highly porous and irregular in shape prevent an effective transfer of pulse through the concrete specimens. As discussed earlier, the substantial amount of pores which are present on the surface and within the internal structure of POC aggregates affects greatly the packing values to give poor interlocking bonding. This is

parallel with findings by Yung et al. (2013b) who mentioned that availability of high amount of voids and water content decrease the UPV values. Besides that, incorporation of POC powder as supplementary powder material does play a part in forming poor configuration between cement particles. As discussed earlier, POC powder tends to reduce the strength of the mortar specimens as a result of dilution and insignificant pozzolanic activity. However, it should be noted that a rise in compressive strength does increase the UPV values as reported by previous studies (Şahmaran et al., 2006; Uysal & Yilmaz, 2011). Figure 5.55 shows the correlation between UPV values and PP of different POC SCC mixes. The correlation obtained indicates that UPV will serve as an equation to predict PP values. From the PP values obtained there is also a possibility of predicting other hardened properties results such as compressive strength, flexural strength, splitting tensile strength and modulus of elasticity.

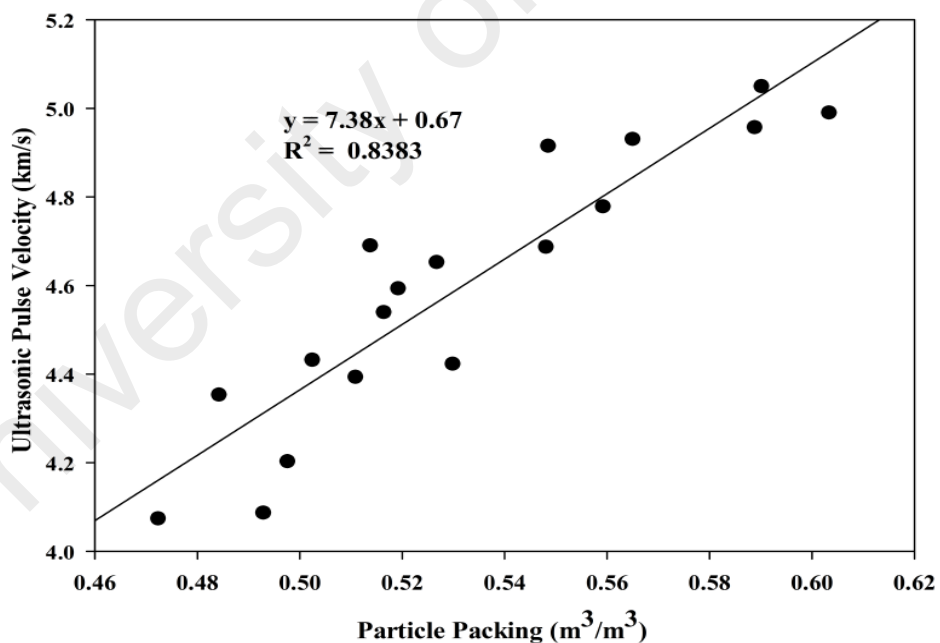

Figure 5.55: Correlation between particle packing and UPV values of POC SCC mixes (28 days)

Figure 5.56 depicts the correlation between density and UPV values of POC SCC mixes. The density of the concrete is heavily influenced by type of aggregates and paste constituents. Presence of honeycombed POC particles reduces the denseness of concrete

mixture to lower the pulse transfer. Control mixes with only gravel and sand showed higher UPV values due to the enhanced concrete matrix and solid state of aggregates.

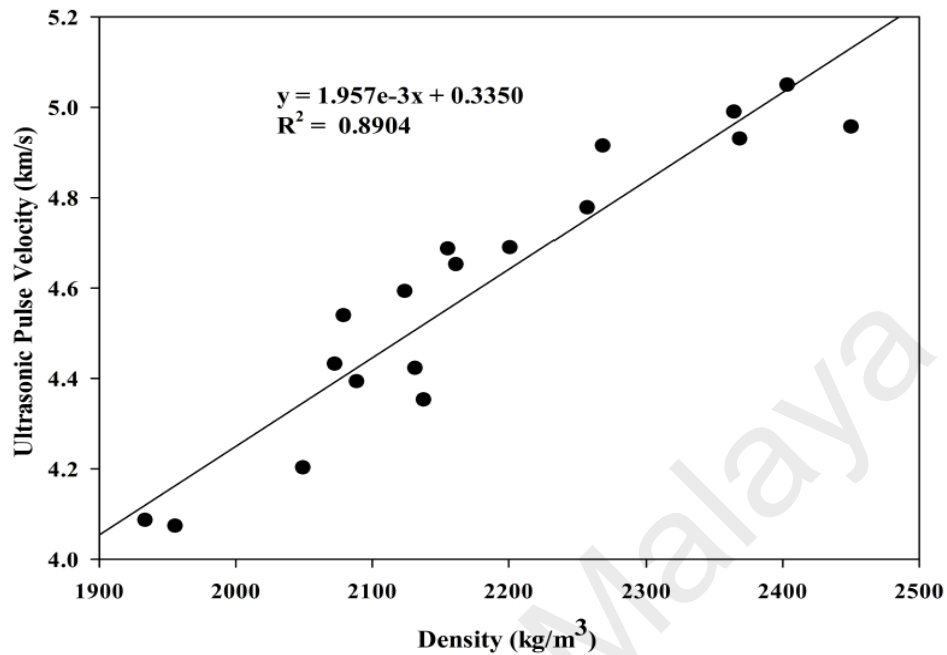

Figure 5.56: Correlation between density and UPV values of POC SCC mixes (28 days)

5.5.3.3 Compressive strength

Figure 5.57 and Figure 5.58 show the effect of POC aggregate replacement on compressive strength for 0.6 F/A and 0.5 F/A specimens, respectively. Despite totally replacing conventional aggregates with POC aggregates, the strength of POC 100 mixes were significantly higher whereby almost 71% and 78% of the POC 0 strength can be achieved for 0.5 F/A and 0.6 F/A at 28 days, respectively which are commendable. Meanwhile, POC 25 showed a comparable strength values to POC 0 for both F/A ratio, where 0.6 F/A mix showed 5% greater strength and 0.5 F/A mix showed only 4% reduction in strength at 28 days. This is indeed a good performance by the mix which can contribute significantly towards the production of high strength concrete using waste material. Other intermediate replacement mixes such as POC 50 and POC 75 also showed substantial strength properties in between POC 0 and POC 100 which make them suitable for common use. Use of larger size of aggregates (10-14mm) either POC

or gravel exhibited greater strength values compared to smaller size of aggregates (5-10mm). This was expected as generally larger aggregates are much more stiffer compared to smaller aggregates and they have greater load bearing capacity.

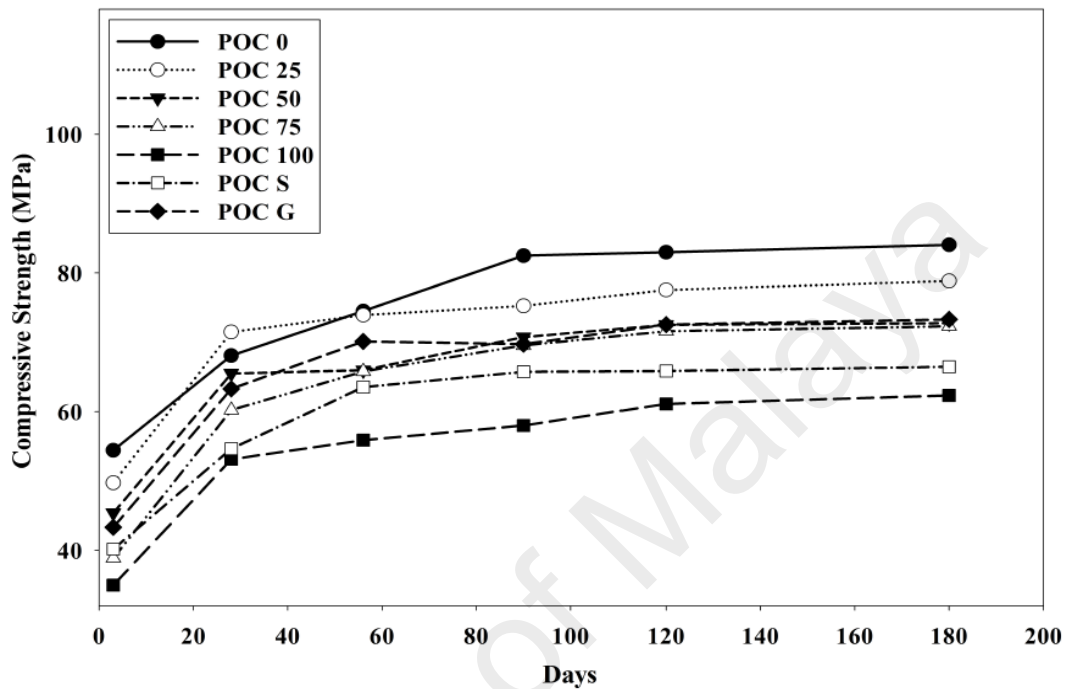

Figure 5.57: Effect of POC replacement on compressive strength (0.6 F/A)

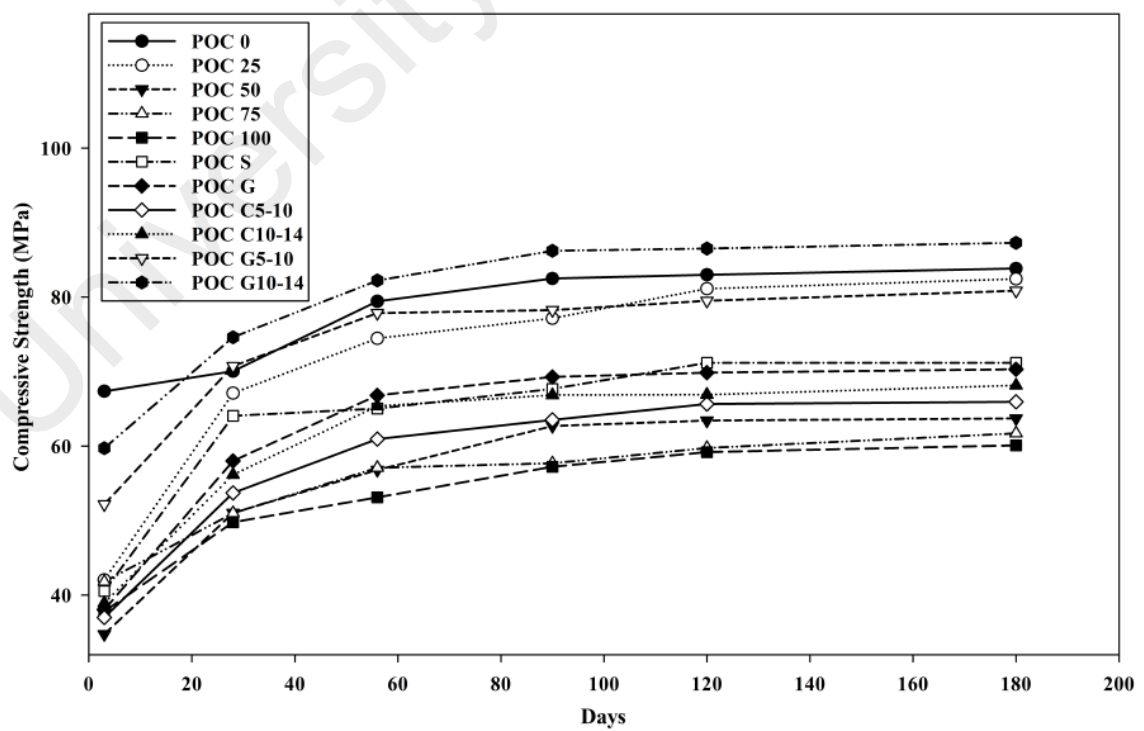

Figure 5.58: Effect of POC replacement on compressive strength (0.5 F/A)

Higher PP values which require lesser paste volume contributed towards higher strength. Presence of greater aggregate content increased the stiffness of the mix to produce higher strength properties for control mixes. Generally, in this study the strength of lightweight POC concrete is affected by the strength of lightweight aggregate, ITZ and bonding between aggregate and paste. As POC is being incorporated at different replacement levels, the void volume increased significantly due to the improper bonding between the normal and POC aggregates which eventually results in lower compressive strength (Lo et al., 2007). Moreover, the strength for POC specimens showed improvement beyond 28 days which can be explained through the self-curing or internal curing of the lightweight POC used in this research. As the water absorption for POC coarse and POC fine is higher than normal aggregates, they may impart self-curing properties on ITZ at later ages. Water that is provided to the cement paste tends to be absorbed into the aggregates during the early stages of casting process. As the cement hydration process begins, these localized water is then provided back to the ITZ (Bentz & Snyder, 1999; Lo et al., 2007).

Besides that, the higher ACV of POC aggregates also greatly impart strength reduction to the concrete. Toughness factor obtained from AIV show that POC is about 6 times weaker compared to normal aggregates. This explains well the behaviour of the aggregate under compression. As reported earlier (section 4.2.4), POC had three times lower crushing values than ordinary gravel. Similar findings were observed in LWA, where the strength sustaining section was focused lightweight aggregate concrete matrix (Faust, 2000). This can be considered as the major contributory factor in reducing the strength of the concrete. Lower strength holding capacity together with high brittleness ratio of POC reduces the ability of the aggregate to sustain heavy load. This was evident from the transition phase from control concrete (POC0) to lightweight concrete (POC 100) whereby the strength achievement decreases steadily. Besides that, the failure zone

in POC concrete may be also due to the highly porous nature of POC. Empty phase or zone present within the aggregates creates a weaker region which may fail abruptly upon exposure to higher load. Studies show that presence of high thermal crack within the aggregates than within the ITZ will induce the crack first in the aggregates (Andiç-Çakır & Hızal, 2012). A similar finding was made by Kayali (2008) whereby for conventional concrete the interfacial zone was known to fail at first, while for lightweight concrete the cracks did not take place at interfacial zone but rather at the aggregates.

Figure 5.59 depicts the relationship between compressive strength and UPV values. The acceptable correlation between them indicates the effect of type of mix and its constituents on the strength achievement. A decrease in strength properties contributed by the increasing lightweight aggregate confirms the effect of aggregate type on the pulse transfer. The physical formation of POC which is rough in texture, irregular and most importantly porous affects the bond or interlocking rate between the aggregate and cement paste. Although this property helps to improve or enhance the 'holding' or 'attachment' strength between aggregate and paste, the weaker and highly void containing POC reduces the denseness of the mix. Generally, researchers agree that the interconnection between lightweight aggregates and cement paste or matrix is different compared to normal aggregates (Wasserman & Bentur, 1997; Ünal et al., 2007; Topçu & Uygunoğlu, 2010). However, it should be noted that all the replacement levels were in the 'good' quality zone highlighting the positive contribution by this aggregate.

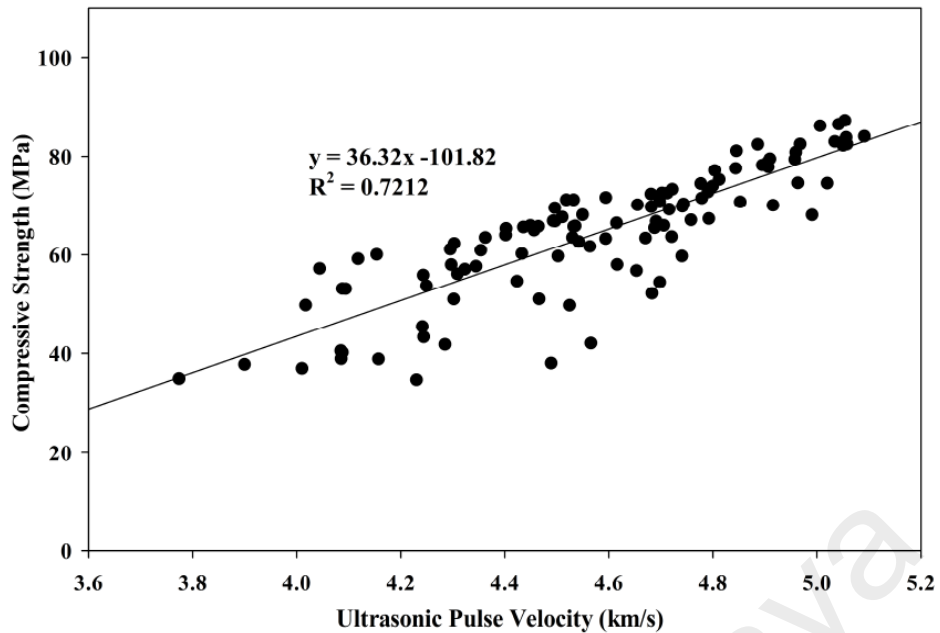

Figure 5.59: Correlation between compressive strength and UPV values

Furthermore, POC powder which is utilised to substantiate the need for extra paste volume also may have played a part in reducing the strength. As described earlier in section 5.3, the dilution effect of POC powder may significantly affect the mix strength. POC powder used in this study is rather acting as a filler material with insignificant pozzolanicity to lower the strength properties. Besides that, POC powder weakens the cement paste matrix due to its own shape and texture as described earlier. Presence of POC powder reduces the attachment strength as the availability ratio of POC powder to cement increases due to lower PP. This can be observed for higher POC replacement mixes whereby the paste volume was higher which required greater POC powder content. Similar to the POC powder mortar studies, the late strength improved significantly at maximum replacement level. This may due to the smaller percentage availability of POC powder between size $10\mu\text{m}$ and $45\mu\text{m}$. It should be taken into account that despite being a waste material, POC managed to produce high strength lightweight aggregate concrete although the high strength property was not the objective of the study. This again affirms the ability of POC to replace conventional aggregates in construction industry.

5.5.3.4 Splitting tensile strength

Figure 5.60 shows the effect of POC addition on the splitting tensile behaviour of the concrete over different ages for 0.6 F/A, meanwhile Figure 5.61 shows the tensile strength results for 0.5 F/A. A decreasing trend can be observed as POC is replaced with natural aggregates for both type of replacement ratios. POC S and POC G samples showed similar tensile behaviour to POC 50 and POC 25 respectively. This could be due to the similar packing characteristics of these mixes. Besides that, the higher surface roughness of POC aggregates might also impart an effect to produce greater concrete tensile strength due to the good interlocking effect. In this study, generally it was found that smaller sizes of aggregates (5-10mm) replacement showed greater tensile strength compares to larger size aggregates (10-14mm) for both POC and conventional aggregates. Smaller size of POC samples produced 10% greater tensile strength compared to larger size aggregates. This was also in agreement with findings in other studies (Bazant & Pfeiffer, 1987; Saouma et al., 1991; Elices & Rocco, 2008). However, it should be noted that POC 100 mix still performed well whereby almost 86% and 76% of tensile strength can be achieved compared to POC 0 samples for 0.5 F/A and 0.6 F/A, respectively. This performance is similar as observed with compressive strength. Figure 5.62 and Figure 5.63 compares the results from this study with available standard curves provided by other codes (ACI 318 and ACI 363). The results obtained from this study remained close to the standard graphs as outlined in the codes despite lightweight aggregate substitution. Majority of the previous studies show that the tensile strength of SCC is generally higher than conventional weight concrete for a certain compressive strength. This could be due to the pronounced effect of additives (Pettersson & Billberg, 1999; Hauke, 2001; Martí-Vargas et al., 2006). As observed, POC aggregate introduction reduced the tensile strength of the concrete which was predicted earlier due to its lower ACV values. According to Neville (1973) and

Bogas (2011), the splitting tensile in concrete is usually affected by three different properties, namely mortar strength, aggregate paste zone quality, texture and aggregate tensile strength. In this study, all the properties listed are likely to be factors in lowering the tensile strength capacity of the concrete. As discussed earlier in POC powder mortar evaluation, generally POC powder inclusion gave a lower strength compared to control concrete. The dilution effect coupled with the poor microstructural bonding reduce the strength of the paste which also leads to lower tensile strength realization.

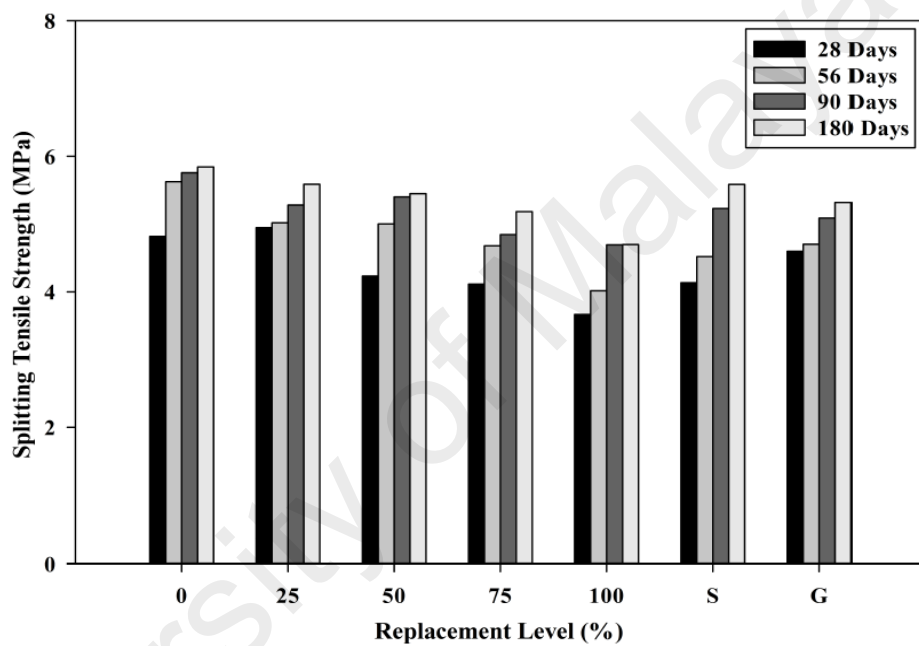

Figure 5.60: Effect of POC replacement on splitting tensile strength (0.6 F/A)

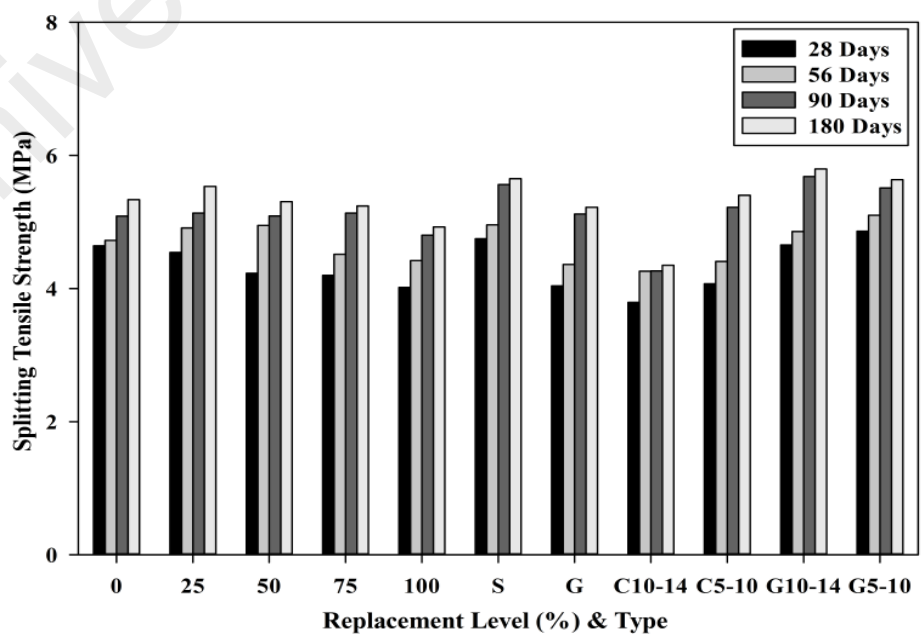

Figure 5.61: Effect of POC replacement on splitting tensile strength (0.5 F/A)

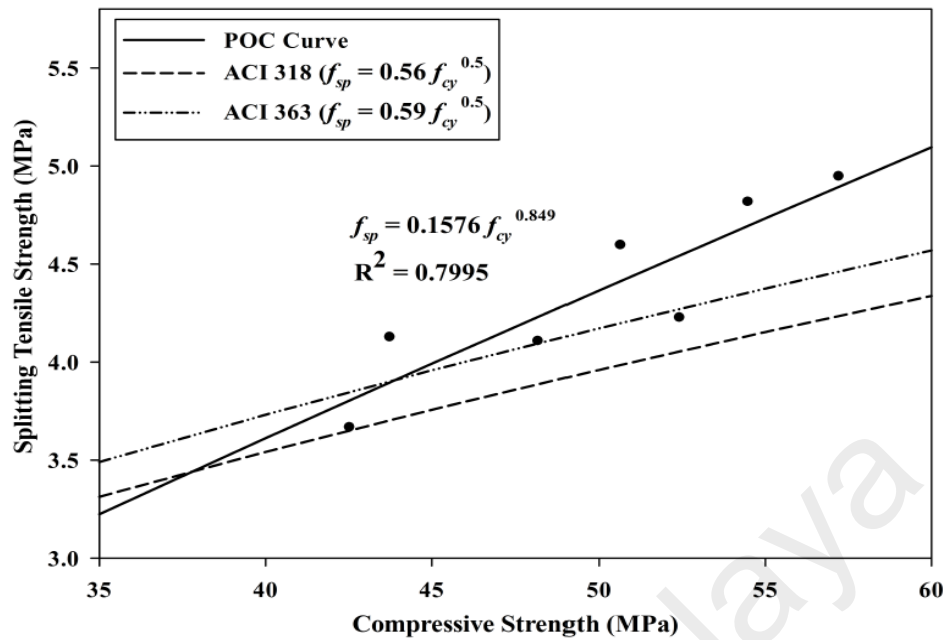

Figure 5.62: Relationship between splitting tensile strength and compressive strength at 28 days (0.6 F/A)

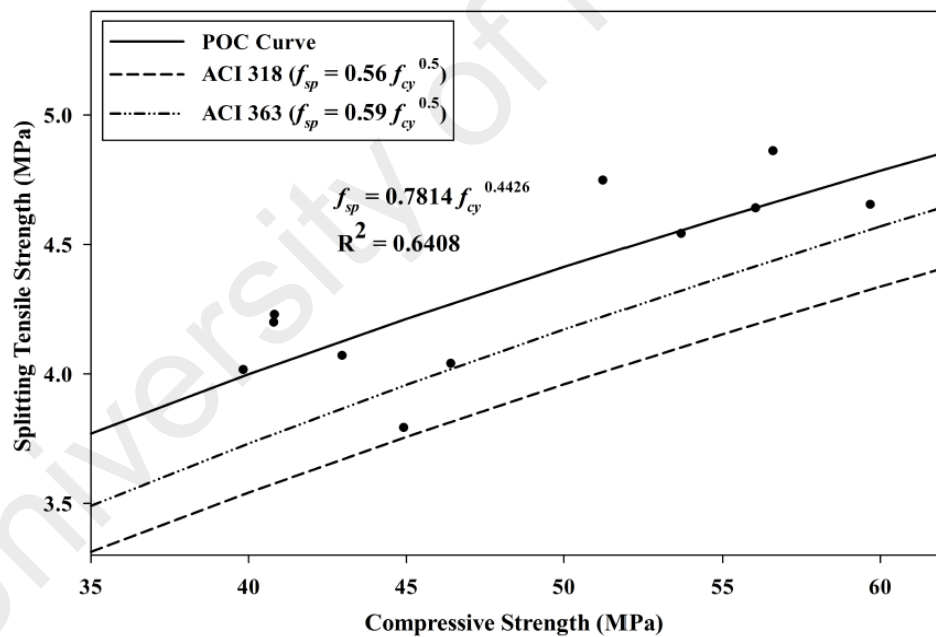

Figure 5.63: Relationship between splitting tensile strength and compressive strength at 28 days (0.5 F/A)

Figure 5.64 shows comparison of failure mechanism between normal and lightweight aggregates. POC aggregates as observed through SEM analysis showed huge empty pores which in return reduced the aggregate mass to produce lightweight aggregate (as observed in Figure 4.3). The high amount of pores connectivity significantly reduces the

strength bearing capability of the aggregates under tensile load. Although the rough texture of POC can create good interlocking effect between aggregate and cement paste, the weaker aggregate still dominates the lower tensile performance. The enhanced interlocking effect between POC and cement paste which is due to the rough texture of POC aggregate hold the aggregate and cement paste region under tensile load. As observed from Figure 5.65 for the splitting of POC 100 cylinder, the flat failure mode confirms that the aggregate failure was predominant compared to the paste. The approximately symmetry failure zone of the cylinder shows that the concrete has very weak aggregates which resulted in lower tensile strength. This property substantially reduces the stiffness of the aggregates to make it more brittle. This finding is similar as reported by other researchers that presence of lightweight aggregates which are much weaker than the paste induces the splitting tensile zone to take place earlier (Choi et al., 2006; Gesoğlu et al., 2014a). In addition, a study carried out by Tian et al. (2015) mentioned that the splitting tensile strength loss for high strength lightweight concrete is higher compared compressive strength which was also found by other researchers (Zhang & Gjorv, 1991; Haque et al., 2004; Yaogang et al., 2009).

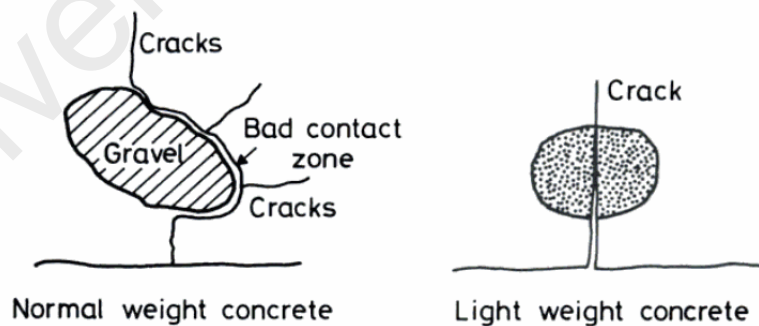

Figure 5.64: Comparison of crack pattern between normal weight concrete and lightweight concrete (Dhir, 1999)

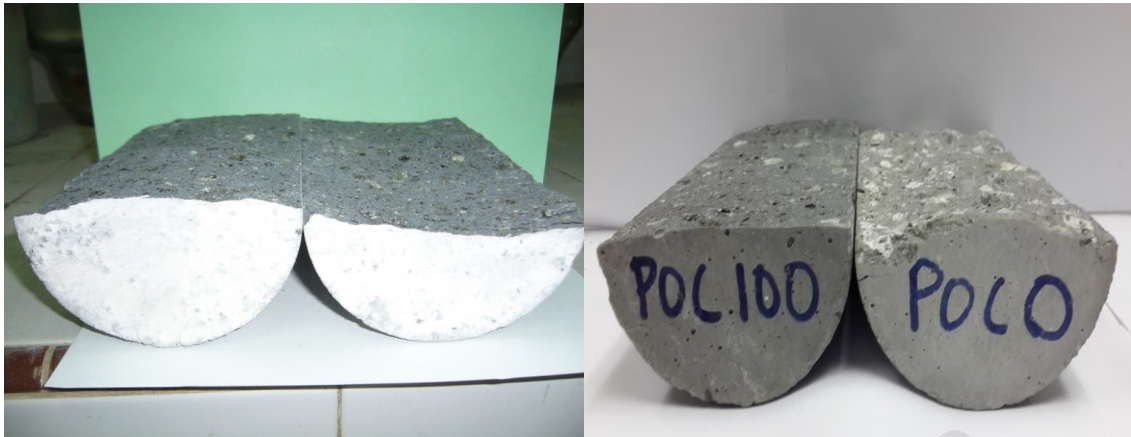

Figure 5.65: Splitting tensile failure zone (horizontal view) on POC 100 specimen

5.5.3.5 Flexural strength

Figure 5.66 and Figure 5.67 depicts the effect of POC replacement on flexural strength. In general, all POC incorporated mixes showed lower flexural strength compared to control mixes except for POC 25 mix at 28 days. POC 25 showed greater flexural strength by 14% compared to control concrete (POC 0) for both 0.6 F/A and 0.5 F/A. However, it is worth noting that POC 100 produced almost 71% of the flexural strength in comparison to POC 0. On the other hand, POC 50, POC 75, POC S and POC G produced almost comparable flexural strength which may be contributed by the close PP values obtained. Larger size of aggregates (10-14mm) exhibited greater flexural strength properties compared to smaller size (5-10mm) owing to its greater aggregate strength or stiffness. As observed, it is evident that the porous nature of POC greatly contributes to lower modulus of rupture properties of lightweight POC concrete. This induces the aggregate zone to fail much earlier compared to the paste region which is generally stronger.

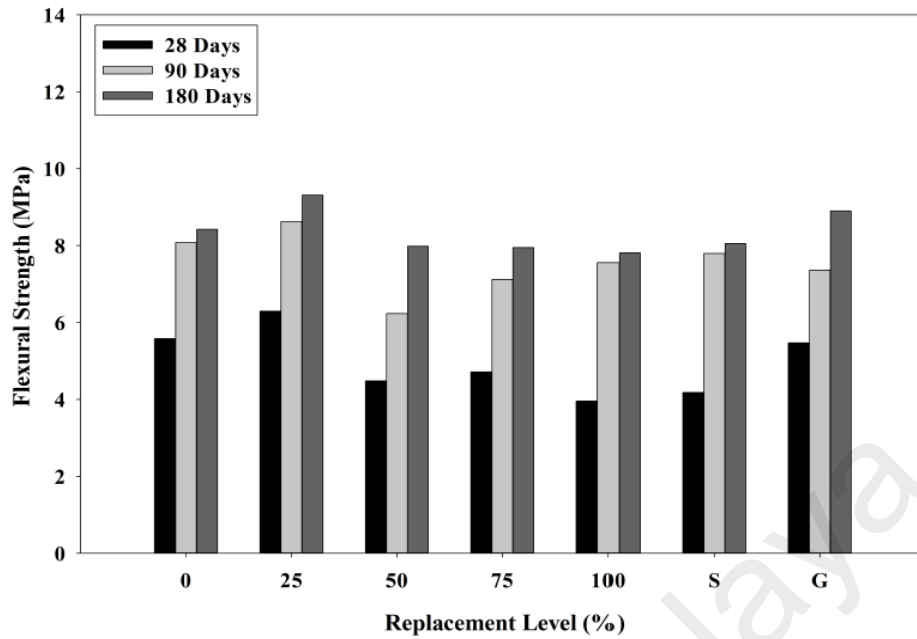

Figure 5.66: Effect of POC replacement on flexural strength (0.6 F/A)

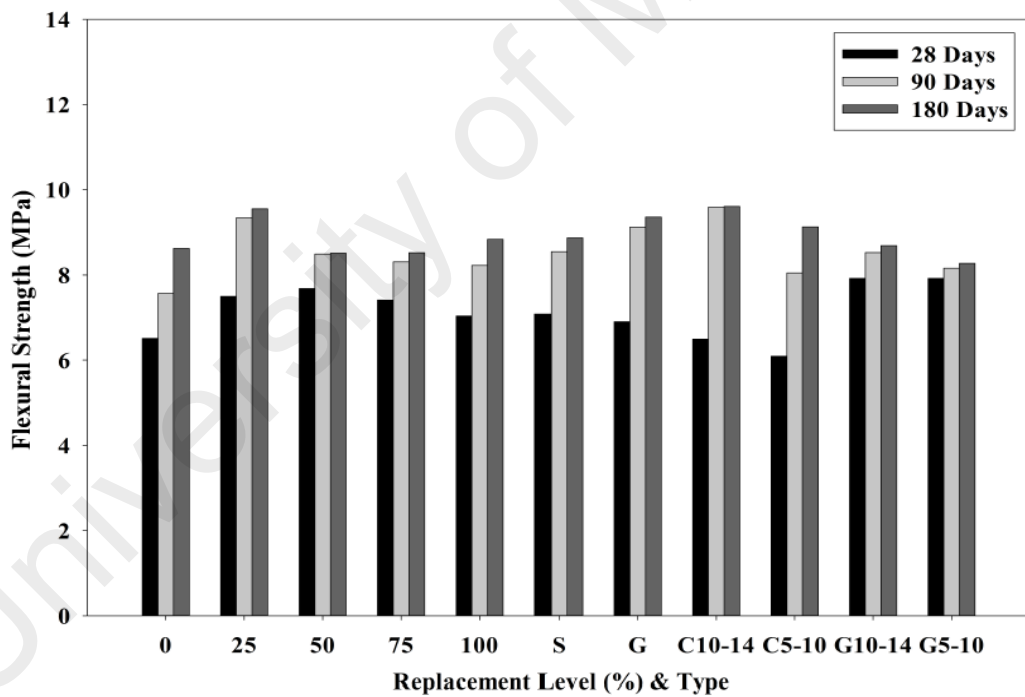

Figure 5.67: Effect of POC replacement on flexural strength (0.5 F/A)

Besides that, the difference in bond between aggregates and cement paste also plays an important role to produce different flexural behaviour. The rough surface of aggregates (POC) produces greater interlocking between aggregate and paste to increase the bond strength (Neville, 1973). POC which is irregular, porous and having rough surfaces induces greater holding force with cement paste to increase the flexural

strength. The VSI gravels might affect the bonding properties at the aggregate cement interface due to its mostly round and smooth finish characteristics. Moreover, studies also show that rougher texture may possibly impart greater adhesive force between aggregates and paste (Neville, 1973). The previous results on splitting tensile strength also strongly affirm that POC concrete behaves similarly under tensile and flexural load. This was an expected trend as the aggregate quality especially the weak POC in this study bounds these two properties.

Figure 5.68 shows the comparison between the curves obtained in this test and standard curves available provided by other codes. There is a variation in the curves which may be due to the presence of lightweight aggregates which will have much lower stiffness compared to ordinary aggregates. The comparison made with the standard curves shows the capability of the POC mixtures to perform similarly to that of normal or conventional aggregate concrete. This justifies the performance of POC as a concreting material. Figure 5.69 and Figure 5.70 show relationships between the flexural behaviour of the concrete and some other important hardened properties. Particle packing plays a vital role in exhibiting different flexural behaviour for SCC. Higher particle packing which reflects on greater aggregate content gives extra stiffness to the concrete matrix resulting in greater flexural strength. Besides that, Figure 5.71 shows the differences in the failure mode between control and POC concrete. A plane or flat failure plane was observed for POC concrete to indicate that POC aggregate may have failed first or at the same time compared to the paste. While for control concrete, the aggregates which are still intact on the surface confirms the high stiffness or strength of natural aggregates which was previously discussed through ACV. Comparing to gravel, POC aggregates which are having three times lower ACV values may impart significant effect to the flexural behaviour as some parts of the aggregates are subjected to splitting behaviour. The highly brittle behaviour may also contribute

towards the significant drop in the rupture properties of the concrete. Meanwhile, Neville (1973) mentioned that when bond between the aggregates and cement paste is good, crushed concrete samples will have some aggregates broken right through besides to aggregates being pulled out of their position entirely. This scenario was evident for most of the POC mixes whereby the failure mode was mostly across the aggregates. Thus, it could be one of the reasons behind the higher range of flexural strength obtained for POC mixes.

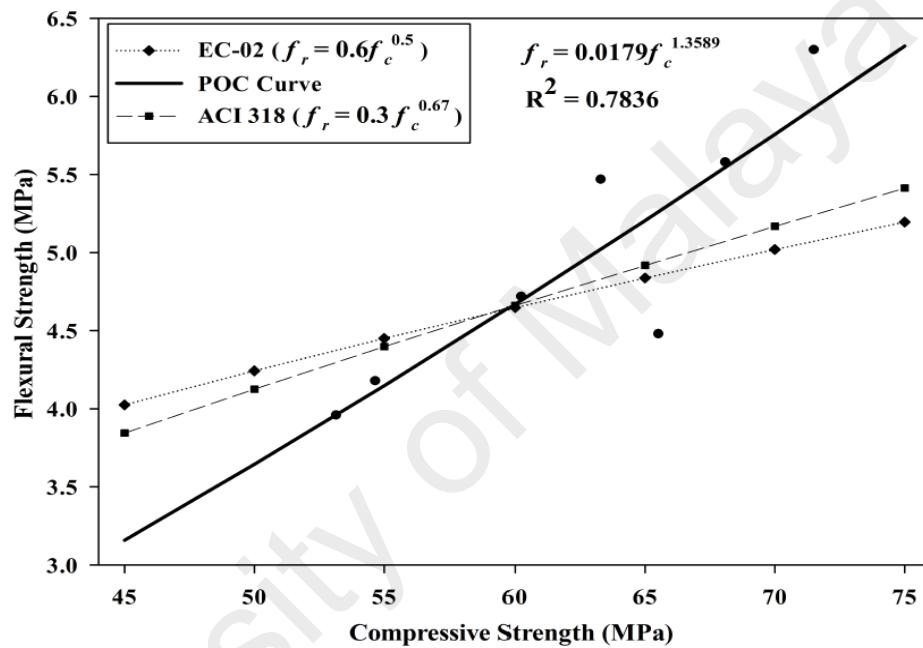

Figure 5.68: Relationship between compressive strength and flexural strength (0.6 F/A)

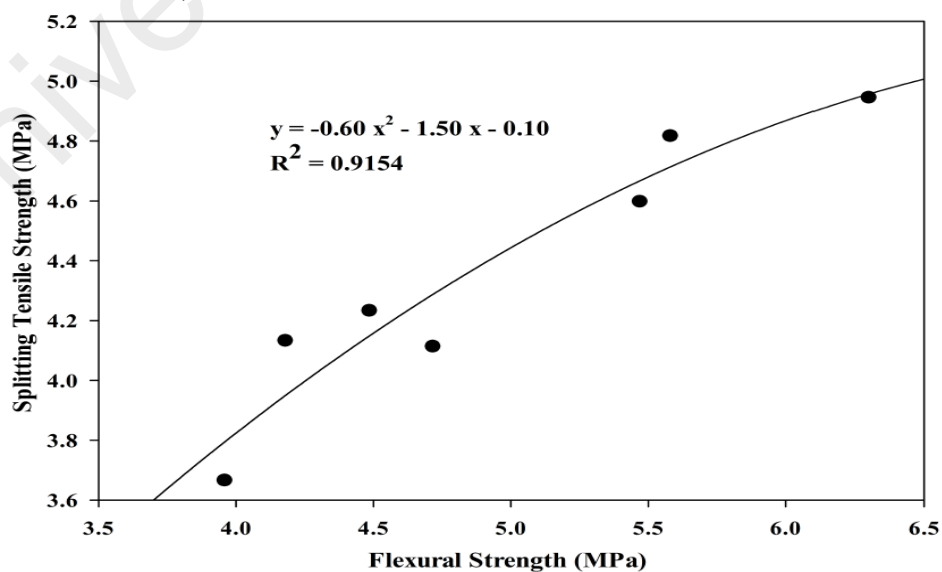

Figure 5.69: Relationship between splitting tensile strength and flexural strength (0.6 F/A)

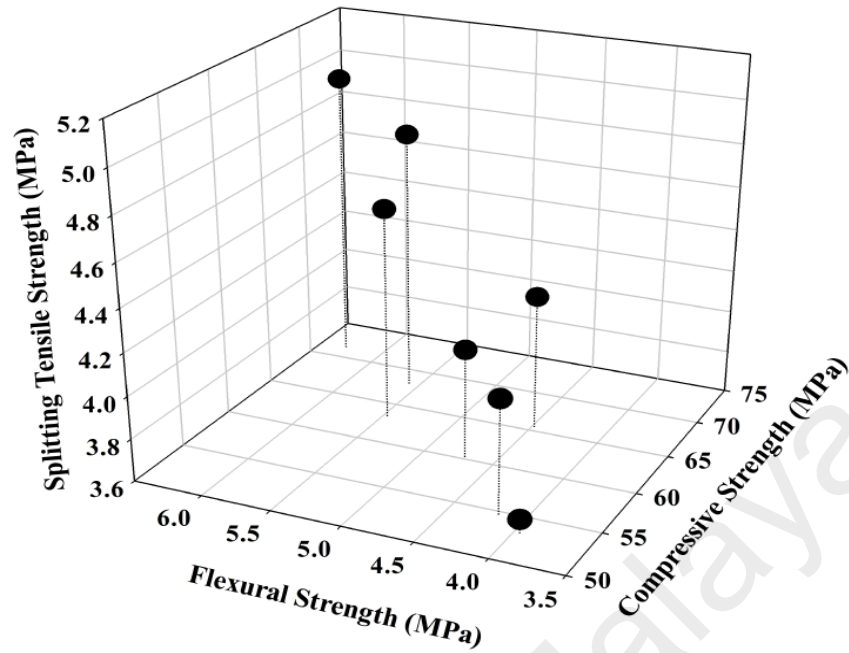

Figure 5.70: Relationship between compressive strength, flexural strength and splitting tensile strength

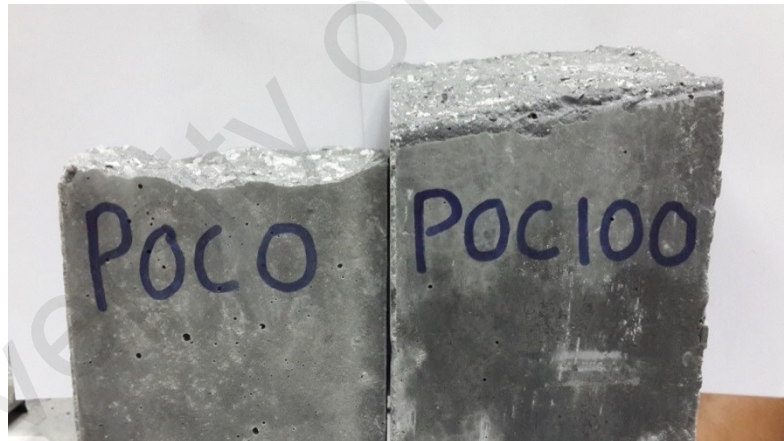

Figure 5.71: Failure mode for POC 0 (control) and POC 100 (side view)

5.5.3.6 Modulus of elasticity

Modulus of elasticity is an important parameter to be considered for structural elements for design purposes. Modulus of elasticity of concrete is greatly influenced by the volume and stiffness of the aggregates (Cui et al., 2012). In this study, the different types of aggregates (lightweight aggregate, POC) were employed in place of natural aggregates with higher paste content of mix may impart different mode of elastic

behaviour. Figure 5.72 shows the effect of POC replacement on elasticity of concrete for 0.6 F/A, meanwhile Figure 5.73 shows the effect of POC replacement on elasticity of concrete for 0.5 F/A. By referring to these diagrams, it is evident that an increase in POC aggregate level exhibited lower elasticity behaviour. POC 100 mixes for 0.6 F/A and 0.5 F/A showed a reduction in elasticity properties by 48% and 40%, respectively. Increment in POC substitution reduces the stiffness of the aggregate phase due to the presence of low strength POC. As discussed earlier, the very weak and brittle nature of POC aggregates is confirmed through lower ACV and AIV (as discussed in section 4.2.5 and 4.2.6). Besides that, the brittle properties of POC also affect greatly the stiffness properties as the rate of crack propagation are relatively quicker in POC aggregates to produce early failure zone compared to natural aggregates. Despite having maximum replacement of POC aggregates in POC 100 mix, it has the capacity to produce half of elasticity behaviour compared to control concrete. Findings in this study is also in line with explanation by Neville (1973) that the elasticity values for lightweight concrete is usually about $\frac{1}{2}$ or $\frac{3}{4}$ of ordinary concrete of similar strength value. Replacement of gravel with coarse POC aggregates whilst maintaining conventional sand managed to produce on average 83% of elasticity properties for 0.6 F/A and 0.5 F/A which is highly commendable. On the other hand, almost 71% of the elasticity behaviour can be obtained when sand is replaced with POC fine, while retaining conventional gravel. Intermediate replacement levels such as POC 50 and POC 25 exhibited substantial modulus of elasticity which is comparable to POC 0.

Besides that, lower packing values corresponding to higher paste volume for higher POC replacement level is also one of the contributory factor. Figure 5.74 shows the correlation between particle packing and modulus of elasticity of POC SCC. As observed, increasing PP value corresponding to reduction in paste volume is in well agreement with the modulus of elasticity. Presence of large quantity of paste or binder

content with significant reduction in aggregate quantity at a lower packing value reduces the stiffness of the concrete (Rozière et al., 2007). The high void content coupled with irregular nature reduces the capability of the aggregates to produce substantially better elasticity behaviour in concrete. Clarke (2002) and Tian et al. (2015) also mentioned that lightweight aggregate concrete has reduced elastic modulus properties compared to that of conventional concrete. Moreover, the larger size of aggregates used in this study (10-14mm) for both natural and POC aggregates produced higher elasticity behaviour. Using greater size of aggregates increased the stiffness of the aggregates and consequently the concrete (Kleinschrodt & Winkler, 1986; El-Sayed et al., 1998).

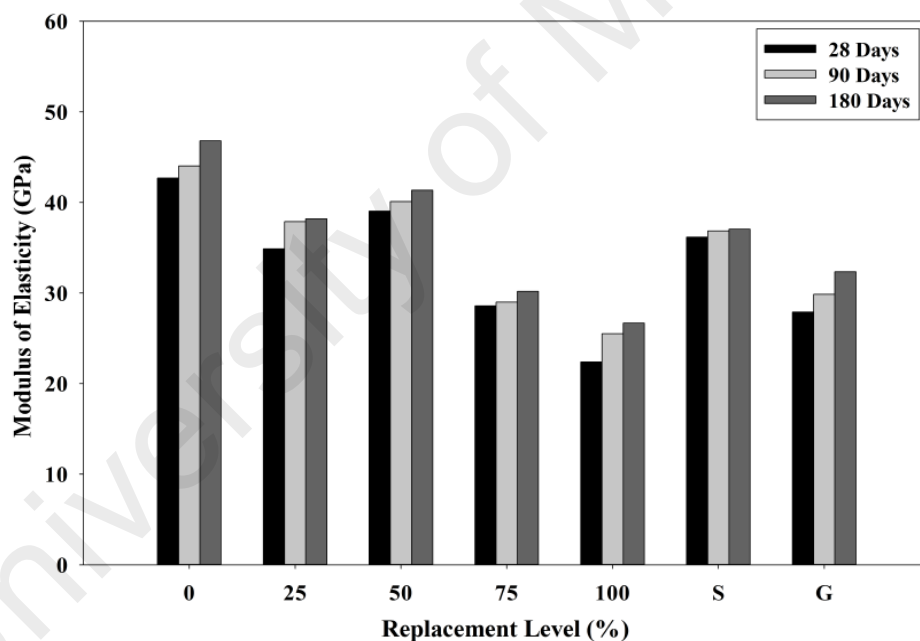

Figure 5.72: Relationship between modulus of elasticity and POC replacement (0.6 F/A)

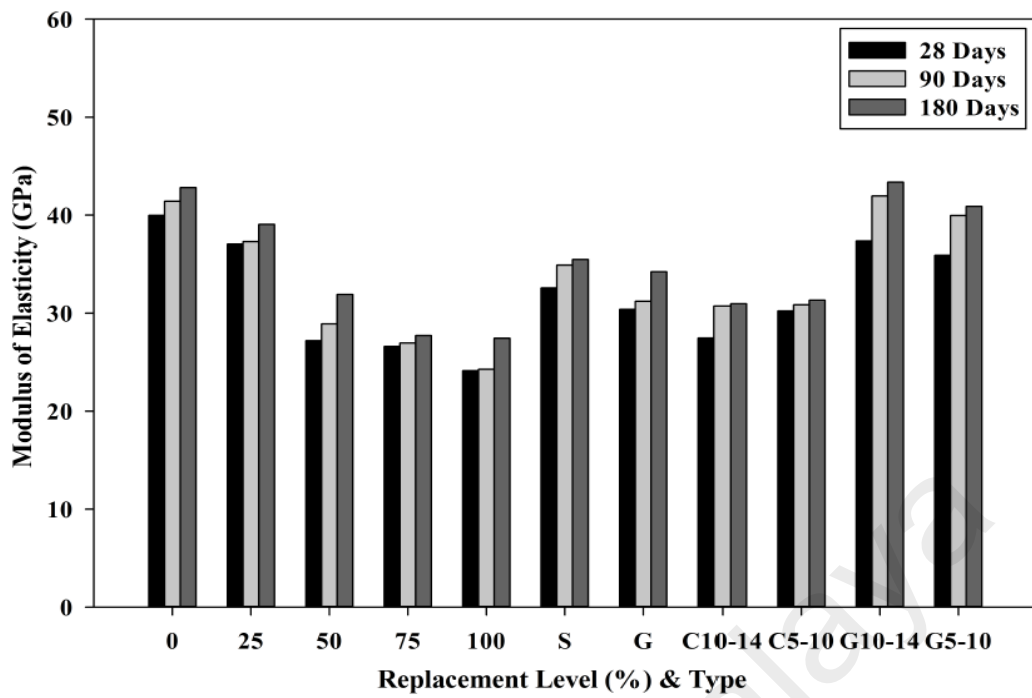

Figure 5.73: Relationship between modulus of elasticity and POC replacement (0.5 F/A)

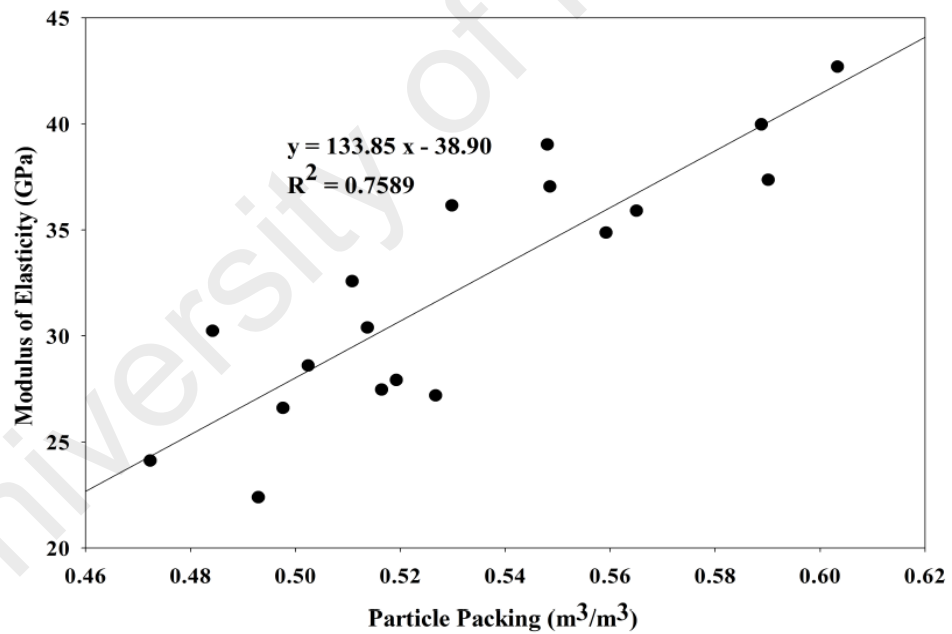

Figure 5.74: Correlation between particle packing and modulus of elasticity of POC SCC

5.5.3.7 Structural efficiency

SE is a ratio between compressive strength and density and it evaluates the concrete potential quantitatively (Videla, 2000; Committee, 2003). This concept was introduced to have a similar platform to compare POC aggregate incorporated lightweight concrete

and conventional concrete. As lightweight concrete has lower density due to the presence of less stiff lightweight aggregates, the strength carrying capacity of the concrete may reduce substantially. Figure 5.75 and Figure 5.76 show the effect of POC replacement on structural efficiency of the concrete for 0.6 F/A and 0.5 F/A, respectively. It can be observed that all the specimens showed similar structural efficiency values whereby the range of the results remained between 0.023 MPa/kg/m^3 and 0.032 MPa/kg/m^3 indicating similar strength carrying behaviour of POC aggregates in concrete despite having lower density. At maximum POC replacement (POC 100), a reduction of SE of about 11% and 5% was observed for 0.5 F/A and 0.6 F/A respectively. As described earlier, POC aggregates are of porous and lightweight nature affects greatly the load attaining capacity of the concrete. However, it is worth noting that despite higher content of POC aggregates and POC powder, the on par performance compared to control aggregates shows the ability of the material to be utilised in concrete. Replacement of gravel with POC coarse (POC S) produced lower efficiency results which may be contributed by the poor interaction between sand and POC coarse particles. While on the other hand, replacement of sand with POC fine whilst maintaining gravel (POC G) as coarse aggregates produced comparable SE results to control specimens. This could probably due to the presence of less large size porous POC particles which usually results in lower strength. Studies carried out on POC fine as a sand replacement material confirmed the high potential of the material to sustain heavy load besides behaving similarly to conventional aggregates (as discussed in section 5.4). Moreover, the particle size distribution and fineness modulus of sand and POC fine are also almost comparable to each other. It can be deduced that POC fine acts as a perfect substitute for sand to produce sufficient SE values. Larger size of aggregates used in this study either POC coarse or gravel showed greater SE values.

This can be explained from the stiffness of concrete concept whereby greater aggregate size increases the strength or stiffness of the concrete.

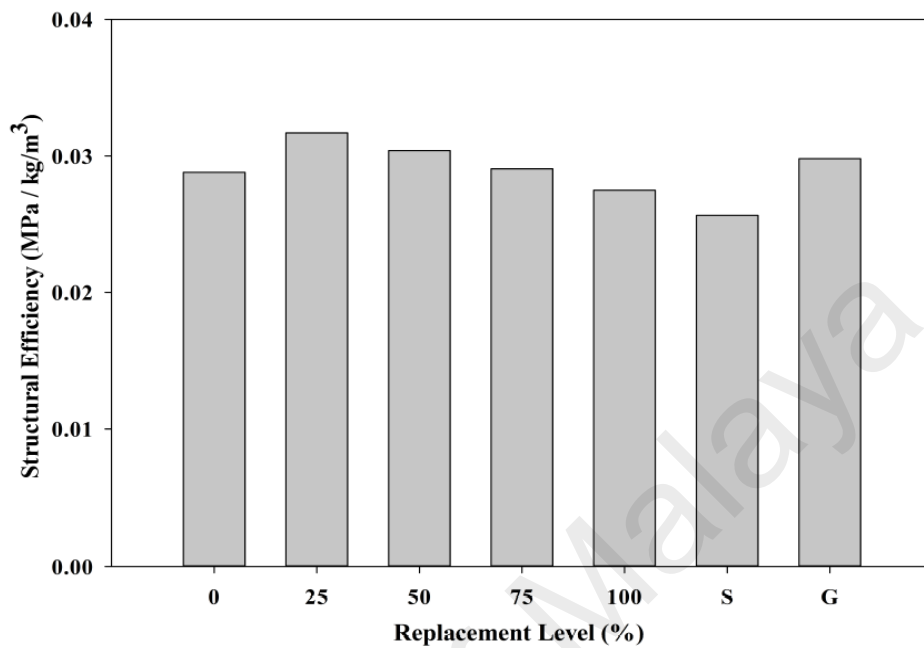

Figure 5.75: Structural efficiency of POC mixes (0.6 F/A)

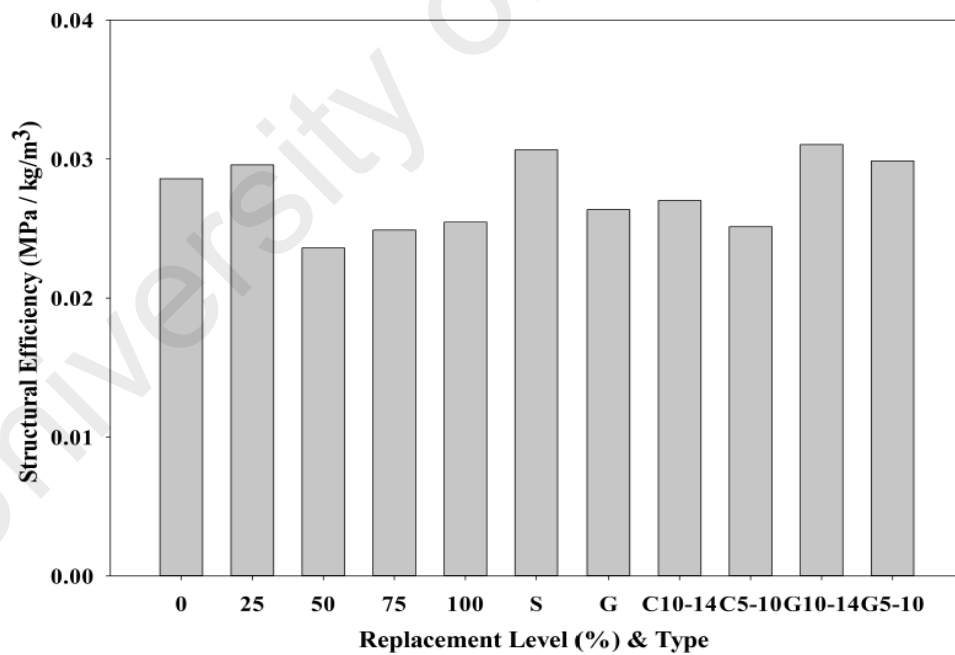

Figure 5.76: Structural efficiency of POC mixes (0.5 F/A)

5.5.3.8 Drying shrinkage

In this study, PP method provided an optimized level of paste volume which may be suitable to coat and provide good flowability to the concrete. Figure 5.77 depicts the

change in shrinkage values of the concrete for different POC replacements at 0.6 F/A. Figure 5.78 shows the variations in shrinkage for 0.5 F/A POC specimens. Generally, the drying shrinkage values of concrete tend to be higher as the cement paste to aggregate ratio is higher (Mehta, 2004; Chatveera & Lertwattanaruk, 2011). It is evident from both the figures that higher POC replacement produced greater shrinkage properties. From PP evaluation, it should be noted that POC 100 mixes for both F/A had about 28% extra paste volume compared to control specimens. The greater paste volume which also incorporates greater volume of POC powder produced higher drying shrinkage. On the other hand, higher PP values or lower paste volume produced smaller shrinkage values. Thus, in this study, a good relationship can be observed between the PP (or paste volume) and shrinkage behaviour. As reported earlier, POC 100 mix which can be categorized as lightweight aggregate concrete produced the highest void content compared to control concrete. The highly porous and irregular shape nature of POC aggregates affects the aggregates arrangement in concrete to produce lower packing value. These characteristics increases the amount of inter voids between the aggregate particles which in turn requires greater paste volume. The higher paste volume used may impart greater shrinkage behaviour as the amount of the aggregates to hold the concrete matrix is lower. Moreover, the lightweight nature of POC aggregates and POC powder also contributes substantially to produce greater shrinkage properties. This is parallel with reported findings by Neville (1973) that lightweight concrete normally would impart higher initial drying shrinkage values about 5% to 40% of conventional concrete. POC 25, POC 50, POC S and POC G showed similar shrinkage values as predicted through similar paste volume proportion. The closer PP range for these mixes plays a vital role in exhibiting similar shrinkage behaviour.

In addition, the high water absorption properties of POC aggregates as reported earlier in physical characteristics section, may also probably a contributory factor in

producing higher shrinkage properties (Anwar Hossain, 2004). Despite that, this factor may not be hugely significant as the paste volume content is much more dominant as compared to the water absorption criteria. Figure 5.79 depicts a correlation between PP and shrinkage at 180 days for all the POC specimens. It is a novel finding indeed to show the how particle packing and corresponding paste volume gives direct change in shrinkage behaviour. Higher particle packing produced lower shrinkage behaviour due to the greater presence of aggregate content. The presence of immense amount of powder particles through POC powder as required through the PP mix proportioning method increases the self-consolidating nature of the concrete to produce greater shrinkage values. This relationship may serve as an indicative measurement of shrinkage for long term studies when POC is used. Despite maximum POC substitution mixes having higher shrinkage characteristics, they are still within the satisfactory region of below $750\mu\text{m}$ as obtained by other researchers (AS 3600, 2004). These mixes may be suitable for applications whereby shrinkage and high load bearing structural components are not required.

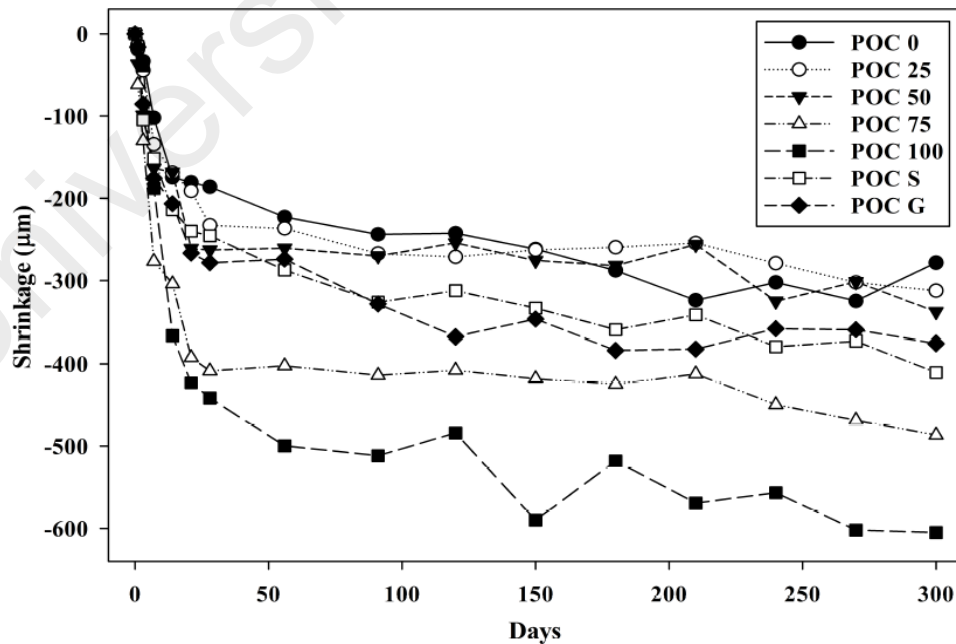

Figure 5.77: Relationship between shrinkage and POC replacement (0.6 F/A)

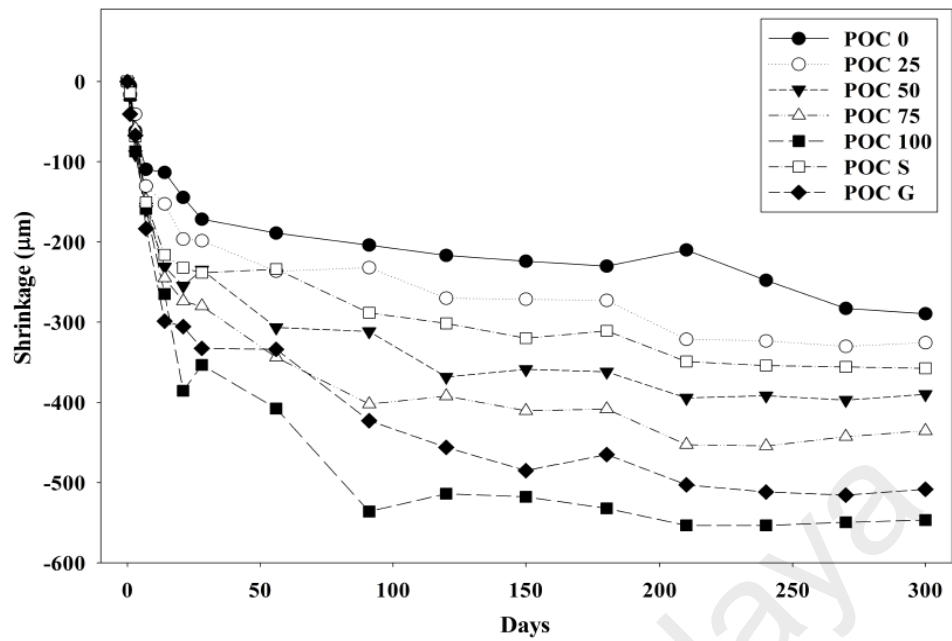

Figure 5.78: Relationship between shrinkage and POC replacement (0.5 F/A)

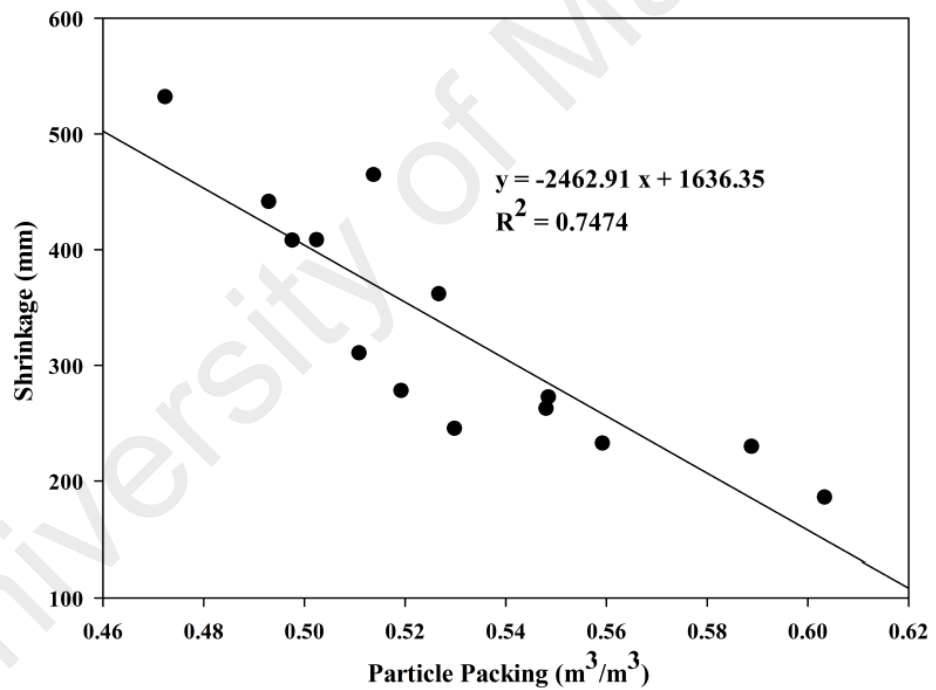

Figure 5.79: Correlation between shrinkage and POC replacement (180 Days)

5.5.4 Durability Properties of POC SCC

The long term effects of using POC in concrete were characterized in this study. They are important as the utilisation of POC which is first of its kind in concrete needs to be assessed completely. This will provide vital information on the change in behaviour of the concrete or mortar under different curing regimes and conditions. In this section, the

durability properties were evaluated through, water absorption test, sorptivity test, sulfate attack, elevated temperature test, RCPT and electrical resistivity test.

5.5.4.1 Sulfate resistance

In this study, a few important mixes were selected to determine the effect of sulfate resistance on the properties of SCC. They were selected by taking into consideration the maximum, moderate and minimum replacement level of POC. Figure 5.80 shows the effect of POC replacement on the relative strength of concrete samples subjected to sulfate solution. In this study, mixed results were obtained on the relative strength properties after sulfate exposure where some the concrete strength on the second cycle improved compared to first cycle despite having a mass loss. Generally, concrete subjected to magnesium sulfate solution may exhibit a mass loss as a result of the high degradation that takes place (Behfarnia & Farshadfar, 2013). In contrast to that, an improvement in strength behaviour was noticed clearly with the replacement of POC. For 0.6 F/A mixes, POC 50 and POC S showed reduction in strength over the last cycle. While for 0.5 F/A mixes, only POC G mix had a lower strength on the third cycle. Studies previously carried out by A. Hassan et al. (2013) showed that all the SCC mixes produced greater residual strength properties compared to water curing regimes. The introduction of expansive ettringite in reaction with tricalcium aluminate with sulfate ion penetration results in dense cement matrix structure. Besides that, formation of gypsum and conversion of C-S-H particles also contribute towards the sulfate attack process. This helps to close the voids within the concrete to contribute towards strength rise. From another point of view, the crystal may fill up the voids within the concrete matrix which will eventually increase the density of the concrete. However, this process is limited as the crystals growth is stopped resulting in stresses that deteriorates the concrete matrix (Neville, 1973). As observed in this study there is a gain in mass for all the specimens irrespective of the mixes. This is due to the filling up of cracks with

water and the water used to precipitate the ettringites (Khelifa et al., 2007). This was also reported by Siad et al. (2013) and further added that the reaction between the cement portlandites and sodium sulfate forms gypsum that also increases the mass of concrete.

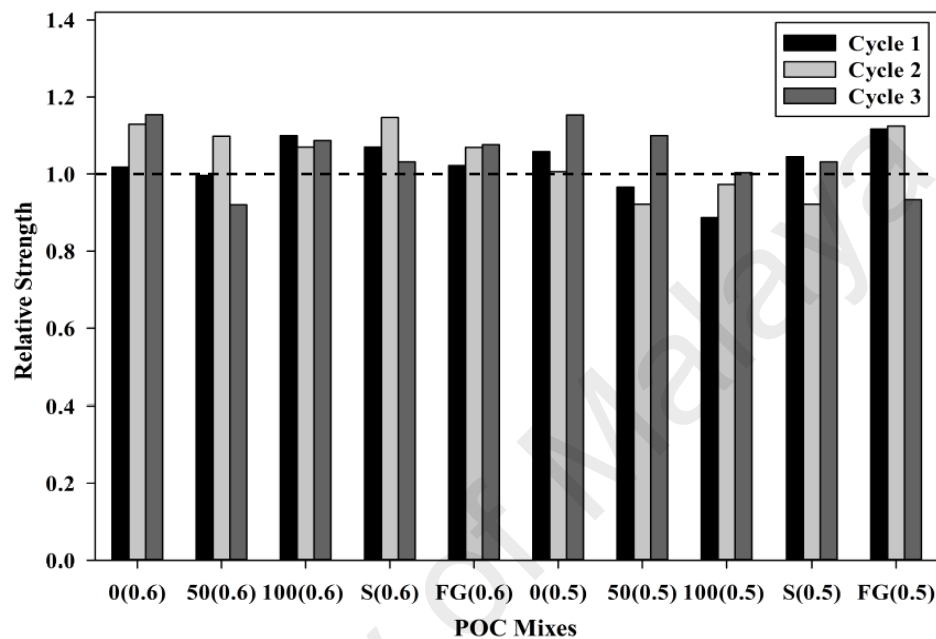

Figure 5.80: Relative strength of POC SCC specimens subjected to sulfate attack

5.5.4.2 Elevated temperature analysis

The elevated temperature test was vital to evaluate the behaviour of the concrete under low, moderate and high temperature region. It is vital to evaluate them, as there is a possibility of obtaining a positive outcome from POC based materials in view of assessing the fire resistance of the concrete. As previously mentioned, POC itself is produced in a palm oil mill under high temperature of about 600°C to 850°C. As the material is already exposed to high temperature regime, there is a need to assess the reaction or changes to the engineering and physical properties at different temperature level. Under the second fire innings, POC may not react or alter even at very high temperature. In this test, POC concrete and POC mortar samples were subjected to three different temperature regime namely low (L-250°C) and high (M-500°C). It should be

noted that maximum internal structure transformation of POC could have taken place at the palm oil mill. This reduces the possibility of having further alteration of POC subjected to further heat exposure. Figure 5.81 illustrates the compressive strength propagation and mass loss for POC 0.6 F/A samples. Interestingly, the strength behaviour showed improvement at 250°C for most of the mixes. All the mixes except for POC 50 showed around 8.8% strength enhancement upon exposure to 250°C mild low temperature. This may be due to the rehydration of the paste as the water within the paste is transported (Dias et al., 1990). The dilution effect of POC powder provides greater storage or retention of water which further increases the level of hydration upon higher greater heat. From another point of view, this may be possibly due to the creation of shorter and stronger siloxane (Si-O-Si) as the silanol groups lose their bond with water particles which eventually increases the strength of the concrete (Khoury, 1992).

A notable difference was observed for POC 75 and POC 100 samples whereby a small reduction in strength properties was obtained upon heat exposure. This correlates to the previous work by Bingol and Gul (2004) who found that mix with lightweight aggregates produced lower strength reduction ratios at all temperature. Besides that, as POC is originally produced through a pyrolysis process that takes place at high temperature in oil palm mill boiler, further temperature increase would be insignificant to create any difference in the physical or chemical characteristics of POC. Generally, lightweight aggregate are much more stable compared to normal aggregates if exposed to high temperature (Clarke, 2002). In addition, a lightweight aggregate has lower chances of having micro cracks as they usually have higher tensile strain capacity. Mass loss of the specimens also plays an integral role in exhibiting the properties of concrete under different temperature regimes. At 250°C heating, the mass loss was not predominant for all the mixes whereby all the values were less than 5%. This was probably due to the evaporation of water particulates from the pores within the concrete.

When the exposure temperature increased to 500°C, the mass loss increased in which most of the POC samples exhibited significant strength loss.

However, an improvement in structural efficiency was noted at higher replacement level indicating the effectiveness of POC as fire resistance aggregates in concrete. Upon increasing the temperature more than 300°C, the water is lost as the C-S-H bond decomposes dehydration of calcium silicate hydroxide and the carboaluminate hydrates (Fares et al., 2009; Pathak & Siddique, 2012). Previous studies also reported that the explosive spalling might take place between 300°C and 650°C. However, in this study, spalling took place only at temperature above 600°C. Other mixes containing higher natural aggregates (POC 0, POC 25, POC 50, POC S and POC G) also showed decrement in strength upon reaching 500°C. This was probably due to the dihydroxylation of portlandite (calcium hydroxide) leading to disintegration of the strength bond resulting in greater strength loss (Ling et al., 2012). Hager (2013) and Khoury (1992) mentioned that β - α quartz inversion that takes place at 574°C results in an increase in volume of the aggregates which may lead to spalling. The cement paste region around the aggregates tends to contract as the heating process causes the aggregates generally to expand which creates a weaker region (Hager, 2013).

Figure 5.82 illustrates the change in colour for POC 100 specimens at 500°C temperature from dark to whitish grey. The presence of iron mineral causes the colour of the aggregates to change into red under exposure to high temperature (Short et al., 2001; Hager, 2014). This may be due to the oxidation process of mineral within the aggregates. A similar finding was made in this study for control specimens. In this study, the mortar and concrete specimens turn into whitish grey when subjected to 500°C. The colour changes are heavily contributed by the water elimination process, cement paste dehydration and alteration taking place within the aggregate structure

(Colombo & Felicetti, 2007). At heating temperature of between 300°C and 600°C the concrete will turn red in colour; while whitish grey between 600°C and 900°C ; and a buff color at 900°C and 1000°C (Short et al., 2001; Colombo & Felicetti, 2007). As of POC aggregates, there were no significant color change under high temperature. This may due to the POC fine itself which is already burned at high temperature at the oil palm mill prior to use as aggregates in concrete.

Figure 5.83 shows the change in structural efficiency of POC mixes when they were subjected to different temperature regimes meanwhile, Figure 5.84 depicts the relative normal strength of concrete under different temperature regimes. As observed on Figure 5.83, only POC 75 and POC 100 mixes showed an increase over SE values as the temperature rises. This confirms that both these mixes which contain maximum POC content do not react or change substantially under higher temperature. Previous studies also showed that use of high volume of POFA which is also a type of waste from the palm oil mill did not significantly cause change to the residual strength properties at initial rise in temperature compared to later higher temperature (600°C) (Awal & Shehu, 2015). The results obtained could serve as a good selling point for POC as they have the potential to produce good hardened properties behaviour despite being exposed to high temperature. Under normal circumstances, building material containing POC be it in the form of aggregates or powder may well serve the purpose of acting as a fire resistance material to reduce the negative structural impacts. POC powder inclusion as a supplementary material without an increase in cement may also contribute to increase the fire resistance properties of a structural element. In this study, the POC powder replacement as a percentage of binder weight was investigated to understand the positive contribution by POC powder as a fire resistance material.

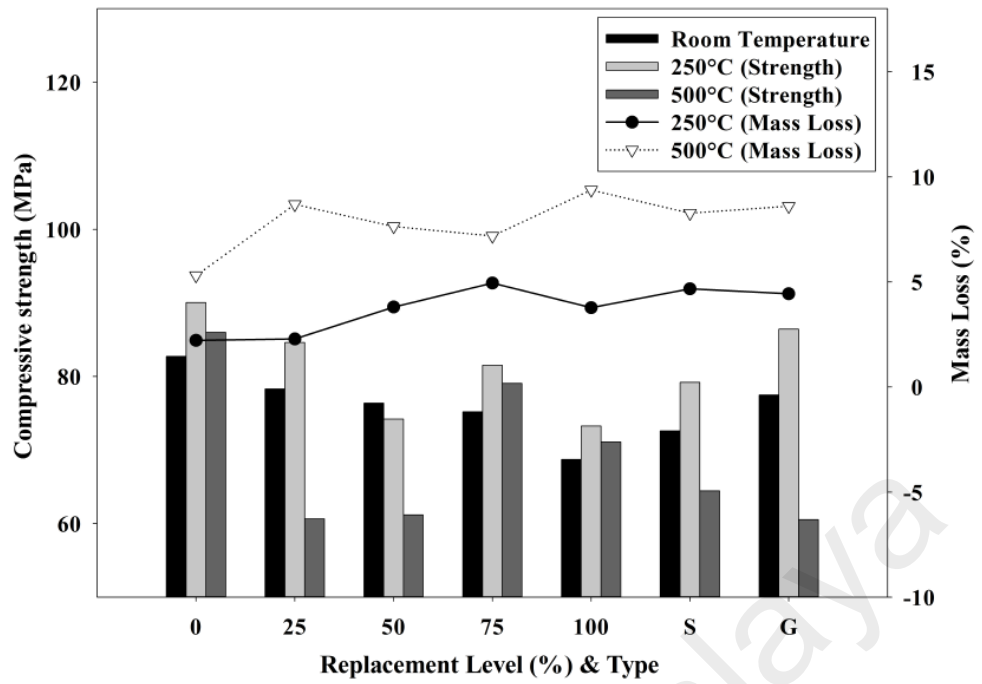

Figure 5.81: Compressive strength and mass loss at elevated temperatures for different POC replacement

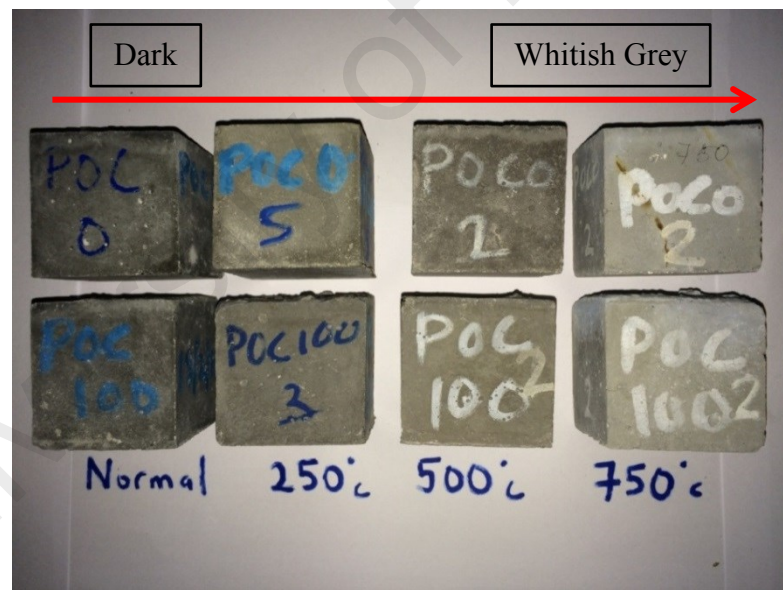

Figure 5.82: Color change between POC 0 and POC 100 specimens

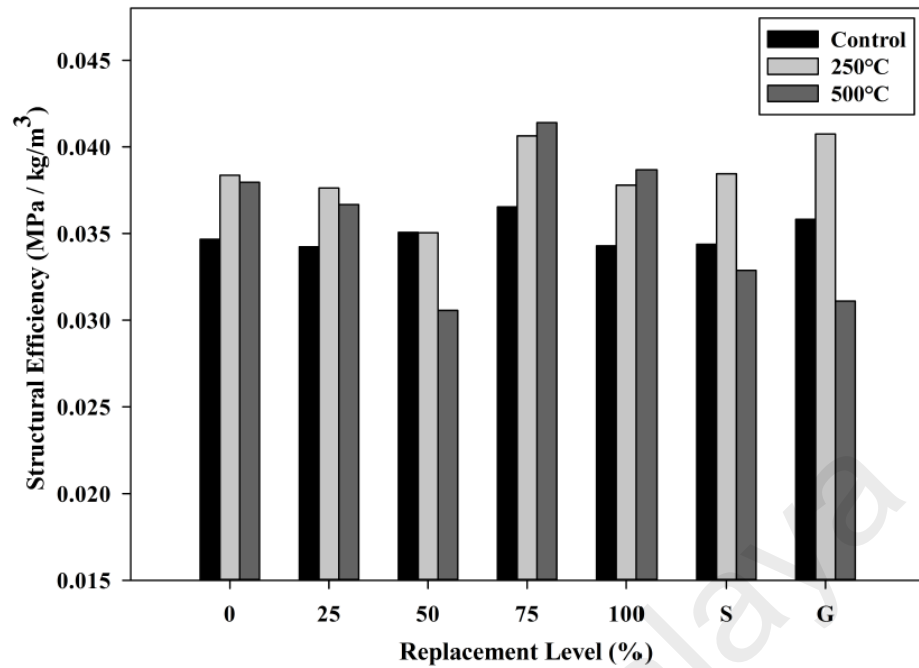

Figure 5.83: Structural efficiency of concrete specimens subjected to different temperature regimes (0.6 F/A)

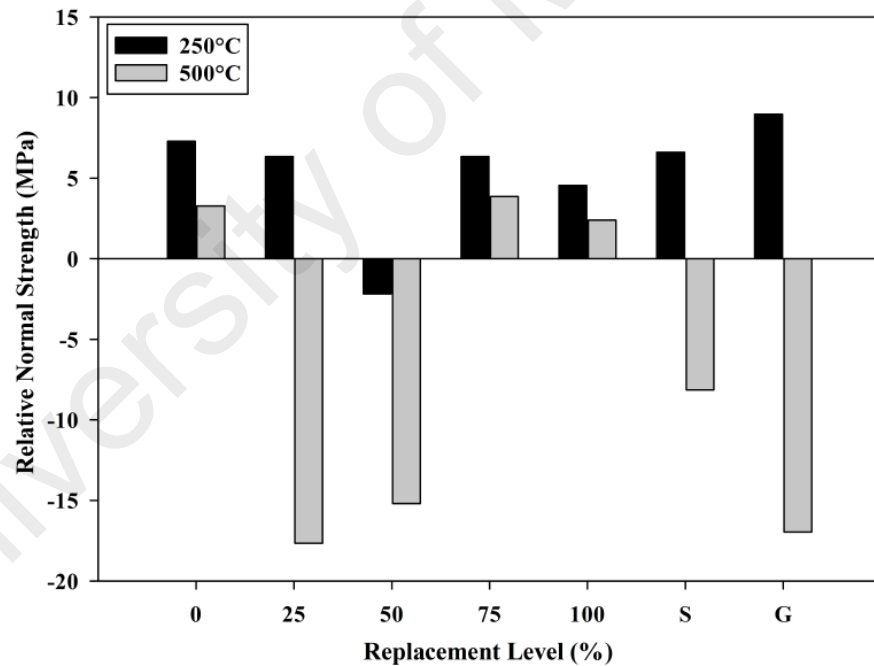

Figure 5.84: Relative room temperature normal strength of concrete under different temperature regimes (0.6 F/A)

5.5.4.3 Water absorption

Water absorption of concrete typically depends on the absorption rate of aggregates and quality of paste. Figure 5.85 shows the water absorption properties for 0.6 F/A meanwhile, Figure 5.86 depicts the water absorption for 0.5 F/A. The ITZ content plays

a vital role in exhibiting the concrete water absorption performance. Addition of POC aggregates and POC powder may have weakened the ITZ due to the low strength, high water absorption and weak pozzolanic properties of POC itself. This affects the water intrusion and porosity properties as the quality of the ITZ is reduced. Besides that, as lightweight aggregates generally have higher water absorption characteristics compared to normal aggregates, the water absorption for POC concrete is also expected to be higher. Increment in POC replacement which corresponds to greater porosity level produces greater water absorption in line with increasing lightweight aggregates. Similar finding was reported on the use of lightweight expanded clay aggregate concrete (Bogas et al., 2014). As observed POC 100, POC S and POC G samples produced greater absorption properties for both 0.6 F/A and 0.5 F/A. POC 100 which is composed of the greatest POC aggregate content (coarse and fine) exhibited about 4% greater absorption value compared to control specimen for 0.6 F/A mixes. This could be due to the presences of higher POC coarse and POC fine which affects the water intake properties. POC G also showed relatively higher water absorption properties of 3% and 1.8% for 0.6 F/A and 0.5 F/A, respectively. This may due to the greater POC fine content replacing conventional sand. Topçu and Uygunoğlu (2010) found from their study that lightweight aggregate concrete produced greater absorption compared to conventional concrete due to the higher water absorption of lightweight aggregates. Above all, lightweight SCC and conventional SCC in this study showed lower water absorption magnitude which varied between 5% and 8% which is similar to the findings of Abdul Razak et al. (2004).

Moreover, the paste quality also plays a vital role in exhibiting greater absorption properties. In this study, SCC and PP method both helped to create an improved bonding between the aggregates and paste. As all the mixes integrated with POC powder, as expected there would be a poor microstructural bonding between cement

particles. This would establish significant capillary pores to impart greater absorption characteristics. Besides that, contribution by fine aggregates also increases the effect on capillary pores. POC fine replacement may also contribute to intensify the water absorption properties. Upon all, the water absorption of all samples in this study is very much within the limits (less than 10%) to define the concrete quality as suggested by Neville (1973) and Senthamarai et al. (2011).

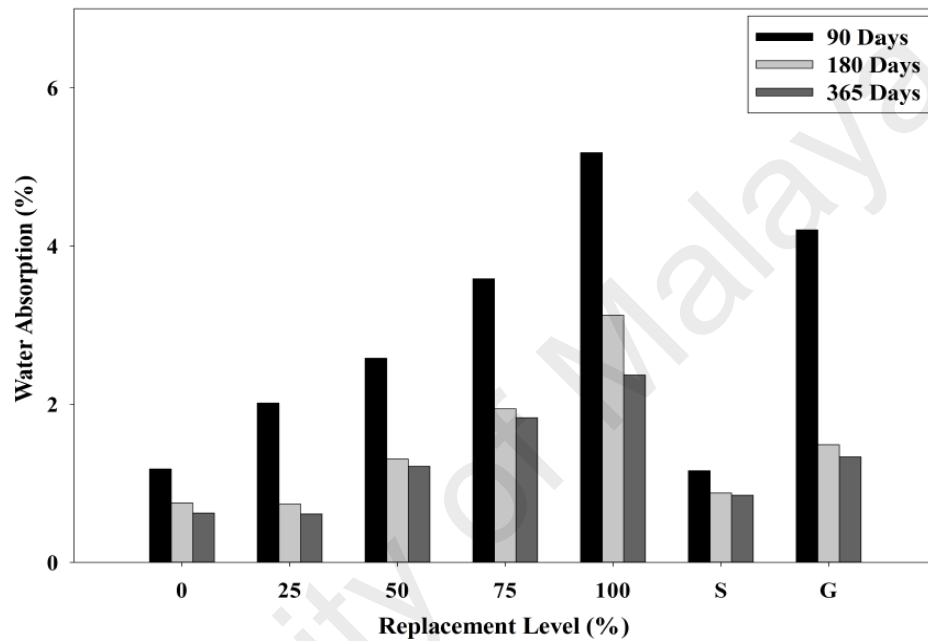

Figure 5.85: Water absorption for 0.6 F/A POC SCC

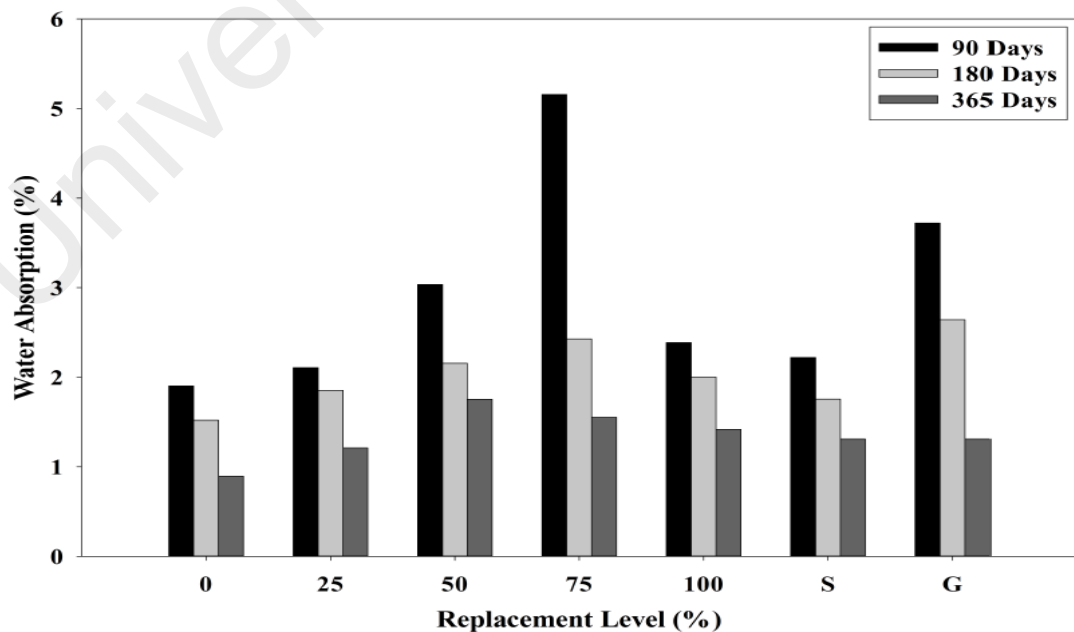

Figure 5.86: Water absorption for 0.5 F/A POC SCC

5.5.4.4 Rapid chloride penetration test (RCPT)

Assessments were made to investigate the performance of POC as aggregates and binder materials in concrete. It is important to evaluate the chloride intrusion properties as it provides an indication on the long term durability features. As this study pioneers the investigation on POC aggregates, it would be an exploratory investigation to exhibit the durability performance. Figure 5.87 shows the RCPT results for 0.6 F/A mixes. While, Figure 5.88 depicts the RCPT results for 0.5 F/A mixes. In this study, POC incorporated concrete produced similar chloride penetration compared to the control concrete. This shows the higher resistance of the material to resist the chloride penetration generally. The special feature of SCC of having extra powder materials to create the self-compacting characteristics may have played a role to resist chloride penetration significantly. In addition, the optimisation of the mix proportion of POC SCC made through PP method provided the required balance between aggregate and paste. Introduction of POC powder further enhanced the concrete matrix especially for higher POC replacement levels. However, higher replacement level of POC lightweight aggregates gave greater chloride ingress as opposed to control mix. This could be solely due to the presence of highly absorptive POC aggregates in the mix. Despite that, POC 100 samples especially on the higher replacement side produced “very low” chloride penetration rate indicating the capability of the material to perform as aggregates. Researchers found that at later ages (beyond 28 days) the chloride ingress values dropped below 1000 coulombs (“low” category) for SCC mixes confirming the high potential of SCC to resist highly chloride content environment (Amrutha et al., 2011). On the other hand, a comparison using conventional concrete showed that the chloride penetration values were still above 2000 coulombs. Coulombs of charges passed at 365 days were lower than at 180 days confirms the enhancement in the concrete microstructure. Presence of high volume of POC fine and POC powder improves the

denseness of the concrete mixture over time which can be also observed through concrete strength propagation. Similar findings were made by Siddique et al. (2015) when spent foundry sand was used.

The higher values of penetration resistance compared to control specimens may be attributed by the presence of higher porosity and sorptivity value of POC incorporation. The shape and microstructural characteristics of POC induces poor concrete matrix to create larger capillaries. In addition, researchers stressed that the concrete using lightweight aggregates as coarse and fine aggregates needs to be assessed for chloride penetration and permeability performance to ensure they can be used as marine structures. They have also underlined three major possible causes of attack by dangerous substance which are pore size distribution, pore tortuosity and porosity (Liu et al., 2011). Presence of higher POC aggregates coupled with greater POC powder content also significantly contributes towards higher porosity ratio. Despite having higher POC aggregate ratio and POC powder content, the special characteristics of SCC improved the ITZ of the concrete to produce lower chloride penetration rate. In this study, POC powder addition to substantiate the voids in concrete further densified the ITZ of the concrete. The fine powder added managed to fill the pores on the aggregates besides giving packed aggregate paste boundary. Researchers also mentioned before that the higher quality of ITZ in lightweight aggregate concrete will exhibit a lower chloride penetration (Bogas & Gomes, 2015). Besides that, it should be also noted that an inclusion of POC powder which are considered as a weak pozzolanic material may also affect the OH^- ion movement. The pozzolanic reaction may lower the presence of OH^- particles causing the reduction in charges (Andrade, 1993; Anil Dogan et al., 2009).

In addition, the optimized packing values obtained through PP study also densified the ITZ region to lower the chloride ingress. This is in agreement with the findings

by M. K. Mohammed et al. (2014) who mentioned that the thickness of ITZ and porosity of ITZ plays an important role in determining the chloride migration coefficient. They reported that the thickness of ITZ is much more effective in producing the chloride penetration than porosity only. Furthermore, increase in sand content does also contribute significantly towards a reduction in chloride penetration. In this study, all the mixes with 0.5 F/A showed lower resistance to chloride penetration as it contains lower fine aggregate content. This finding is also similar to those obtained by Delagrave et al. (1997) for mortar specimens. Studies also show that despite having higher chloride penetration at early ages for lightweight concrete mix, the values reduced drastically at later ages (Gesoglu et al., 2014a). Decrement in chloride penetration upon age shows the enhancement in density of the concrete. SCC with optimized PP values gave lower void content leading to denser capillary pores which could not have significant chloride penetration. This can be also observed through increase in strength values for concrete samples. Siddique (2013) also investigated and found that microstructure of the concrete became denser as age lapse which is obvious through the greater strength values.

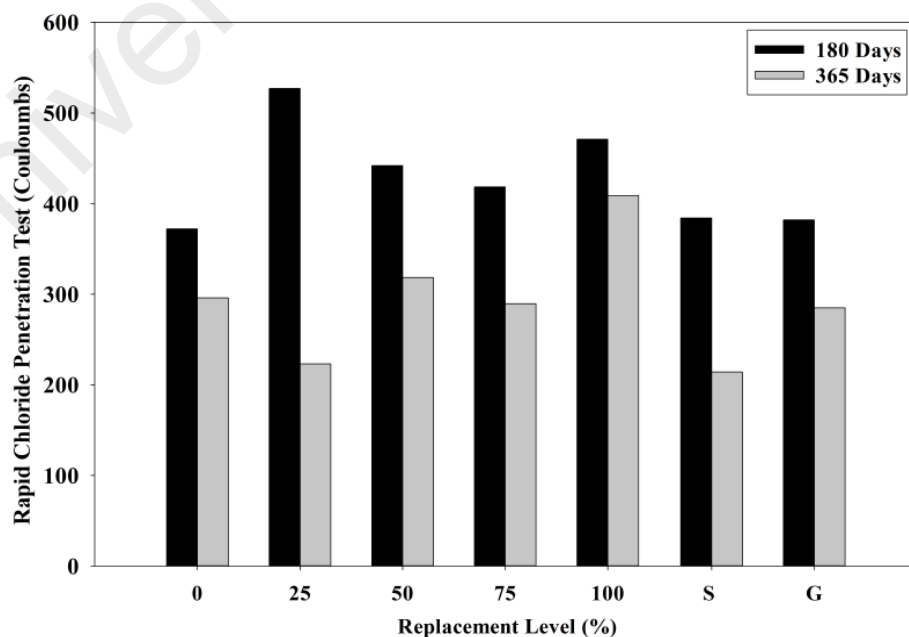

Figure 5.87: Rapid chloride penetration test (0.6 F/A)

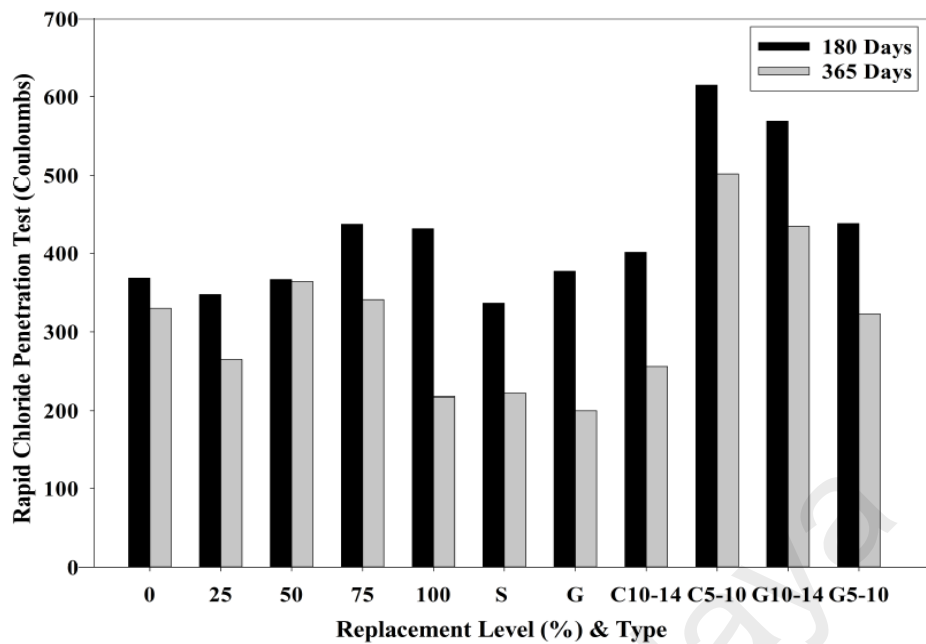

Figure 5.88: Rapid chloride penetration test (0.5 F/A)

5.5.4.5 Sorptivity

Figure 5.89 shows the sorptivity results for 0.6 F/A mixes meanwhile, Figure 5.90 depicts the sorptivity results for 0.5 F/A mixes. As observed, the increasing POC replacement level produced greater sorptivity coefficient. Control specimens produced on average 63% and 128% lower sorptivity values at 90 and 180 days for both 0.5 F/A and 0.6 F/A compared to maximum POC replacement mix. This was predicted earlier as the presence of greater lightweight POC aggregates coupled with the presence of high POC powder content to supplement the need for extra paste would increase the porosity of the concrete. Introduction of POC aggregates in the form of POC fine and POC coarse which are having higher water absorption properties increased the sorptivity coefficient. This may be due to the highly porous nature of these lightweight aggregates. The high absorption characteristic of POC affects the water intake into the aggregates to produce higher sorptivity coefficient. Similar findings was also reported by Gesoğlu et al. (2014a) when natural aggregates were substituted with lightweight fine and lightweight coarse aggregates. They also added that the higher porosity of the lightweight aggregate may degrade the quality of the concrete matrix resulting in poor

capillary structure of the concrete. POC G which has POC fine as a total sand replacement material provided higher sorptivity coefficient almost similar to POC 75 and POC 100. This is could be majorly due to the well-known higher absorption properties of POC fine (as reported in section 4.2.1). It should be noted that, despite the high absorption properties of POC, all the results showed lower sorptivity values which were expected due to the lower water binder ratio of the mixes. The porosity and pore structure of the concrete is much denser with lower water binder ratio causing significant resistance to penetration of external particles. A study proved that increasing water cement ratio from 0.30 to 0.55, elevated the water porosity from 5.8% to 16.1% respectively (Liu et al., 2015).

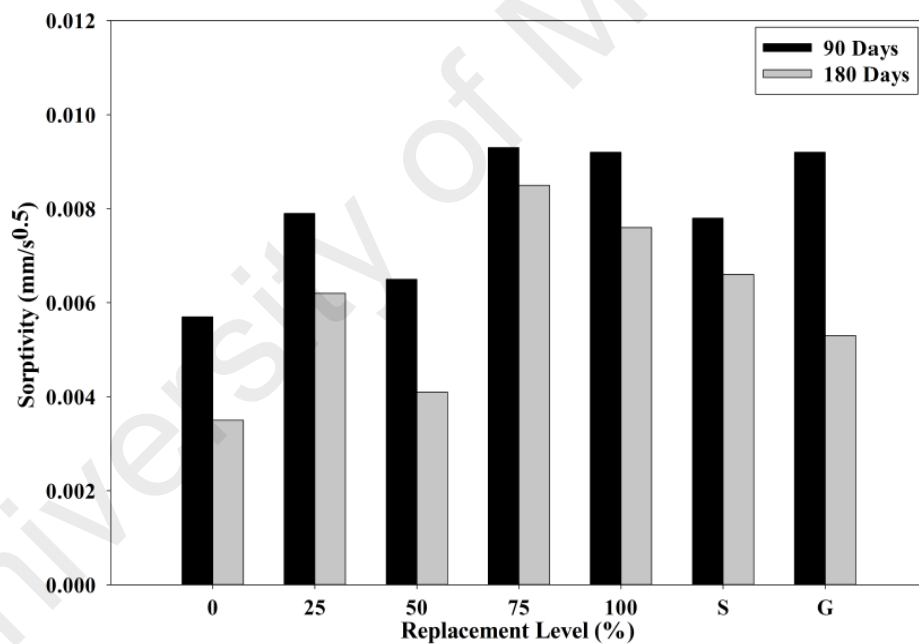

Figure 5.89: Sorptivity values for 0.6 F/A mixes at different replacement levels

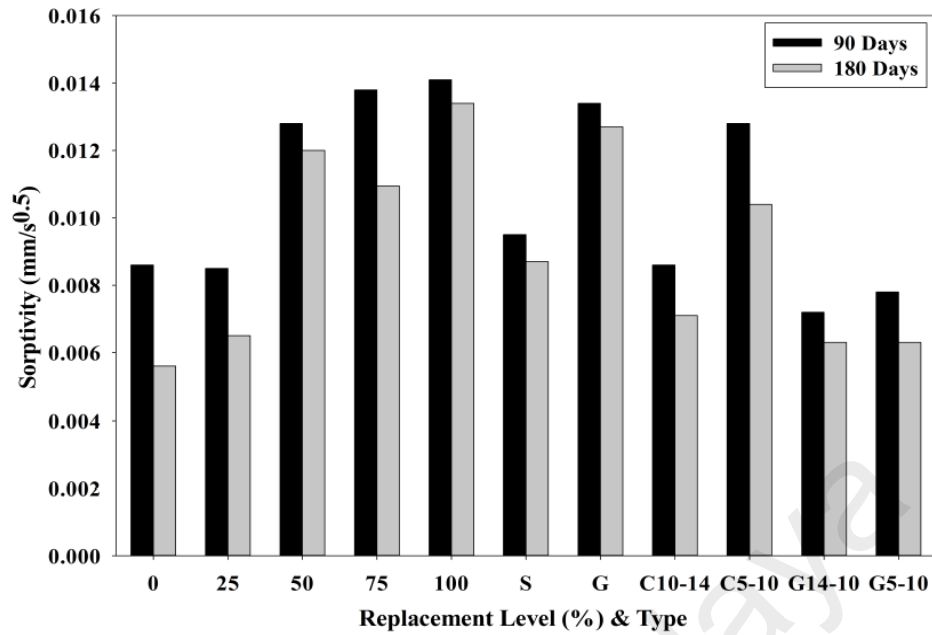

Figure 5.90: Sorptivity values for 0.5 F/A mixes at different replacement levels

Moreover, the poor interlocking bond within the POC aggregate resulted in extra voids. Although this was addressed by introducing POC powder to substantiate the void through PP method, presence of POC powder which is also high absorptive increases the sorptivity of the concrete. Introduction of POC aggregates into the mix increased the void volume as observed through the lower PP values. Conversely, higher paste volume was required to improve the PP to provide the required fresh SCC and hardened properties to satisfy structural requirement. Higher paste volume is more susceptible to greater capillary pores. Generally, addition of powder materials (i.e metakaolin, silica fume) tends to improve the filling effect of the concrete which improves the permeability (Abdul Razak et al., 2004; Saleh Ahari et al., 2015). However, in this study, as POC powder was used as an additional powder material instead of other conventional powder material, the irregular shape of the powder may create poor interlocking bond with cement. This was proved with the greater water absorption values for higher POC replacement level besides the high absorptive behaviour of POC aggregates. This is also in agreement with the findings by Dogan and Ozkul (2015). Besides that, according to Neville (1973), generally higher paste strength produces

lower permeability properties. In this study, as the POC powder involvement increases together with POC aggregates replacement, reduction in cement content per volume of paste volume reduces the paste strength as well. As discussed earlier, the dilution effect and particle characteristics are the few of the pronounced effects leading to lower strength properties. Other studies also supported the findings in this study that an increase in porosity and mean pore size of the concrete due to lightweight concrete incorporation led to a higher capillary in concrete (Liu et al., 2011; Gesoğlu et al., 2013).

5.6 Non-Structural Application of POC for Commercialisation

The positive contributions by POC fine and POC powder in POC concrete from fresh, hardened and durability points of view indicate the applicability of the material in the construction industry. As a research must lead towards an invention or an application, POC aggregates and POC powder were further developed to be utilised in the pre-cast industry. Two prototypes for commercial applications namely POCDRA (Palm Oil Clinker DRain) and POCON (Palm Oil Clinker OrNament) incorporating high volume of POC were introduced to evaluate the effectiveness and contribution by this material for on-site application. Being aware of the corporate social responsibility, these two products were designed to lower the production cost of the precast industry besides enhancing the sustainability and environmental elements. Applying the concept of 'research leading towards product', the engineering and sustainability values of the commercial values were further evaluated. All the three different forms of POC were utilised in this study to evaluate these products. They are POC aggregates as coarse aggregate replacement, POC fine as fine aggregate replacement and POC powder as cement replacement material. Table 5.7 shows the different types of mixes that were prepared to evaluate the durability and engineering properties test for these products. The mixtures were designed at attaining the minimum cement utilisation and maximum

waste material incorporation. These mix design were based on SCM mix and micro-concrete which further enhances the finishing and properties of the drain and ornament. Micro-concrete can be defined as mortar phase with coarse aggregates less than 10mm. POC coarse and gravel substitution were studied through micro-concrete, meanwhile POC fine, sand and POC powder were investigated through SCM. These mortar specimens were subjected to strength test to ensure they are within the required hardened properties range. Compressive strength test was carried out at 28, 56 and 90 and 180 days to check for strength variation and performance. These samples were prepared and cured as the current practice of conventional precast industries. The values then were integrated for structural efficiency concept to understand the effect of different types of aggregates and powder materials in concrete.

Table 5.7: Mix proportion for POCDRA and POCON

Mix	Sand	POC Fine	POC Coarse	Gravel	Cement	POC Powder
A	100	-	-	-	100	-
B	100	-	-	-	50	50
C	-	100	-	-	50	50
D	-	-	100	-	50	50
E	-	-	-	100	100	-
F	50	50	-	-	100	-
G	50	50	-	-	50	50
H	-	50	50	-	50	50
I	50	-	50	-	100	-
J	50	-	50	-	50	50
K	50	-	-	50	100	-
L	50	-	-	50	50	50
M	-	50	-	50	100	-
N	-	50	-	50	50	50

All the numerical values are expressed as percentage

5.6.1 Palm Oil Clinker Drain (POCDRA)

Figure 5.91 shows a POCDRA specimen. POCDRA prototype was initiated to tackle the acidic soil nature problem faced by the agricultural industry. Sabah and Sarawak (Borneo states, Malaysia) which are rich in peat soil require urgently a construction

solution to avoid the corrosion and deterioration of the drain due to the highly acidic nature of the soil. The oil palm plantation estates have been facing this problem for a number of years and are looking for an affordable solution to prolong the life span of these drains. Use of POC in POCDRA mixtures expected to reduce the presence of calcium elements present through cement and increase the ratio of POC (majorly silica). This might reduce the rate of damage to the drains as the acid resistant silica can help to contain the leaching of the concrete or mortar matrix. A real site test is expected to be conducted in future on these drains whereby, two estates will be randomly selected through a proper procedure and arrangement. The introduction of this waste material originating from the palm oil industry itself as powder and aggregates would be a ‘win-win’ situation for most of the plantation estates as the waste is readily available on a daily basis besides cutting down significantly the cost of the drains. As the high strength is not a major discussion point, minimum hardened properties drain can be prepared with higher proportion of POC powder and POC aggregates.



Figure 5.91: A POCDRA sample

5.6.2 Palm Oil Clinker Ornament (POCON)

POCON was prepared to be used as an architectural enhancement material for the local construction industry especially the precast industry. Figure 5.92 shows a POCON

prototype established through this research. The main aim of this product is to ensure that the research contributes significantly to development of novel elements which are useful and cheap for residential use. A proper structural test was conducted on ornament specimens to evaluate the maximum strength load to ensure that it conforms to the minimum load bearing capacity of the real life structure. Special truss system was introduced to avoid the need to use steel reinforcement within the ornament. As this specimen will be placed just below the roof holder and between few layers of bricks, the maximum load the specimens can sustain was determined through a structural test. A direct spread load was applied on these ornaments to simulate the real life load transfer system. The test was performed according to ASTM C140 (2015). A constant load was applied across the POCON sample to measure the maximum failure load that can be taken. A standard pace rate of 2.4kN/min was used to direct the load on the specimens. A specimen holder was fabricated specifically to test these specimens to ensure the load transfer is even and consistent. In this test, the maximum load upon failure gives an indication on the maximum load that the ornament can sustain when subjected to load.



Figure 5.92: A POCON sample

Figure 5.93 shows the compressive strength results for all the mortar mixes that were tested for POCON. It should be noted that the lower range of results for POCON samples (40MPa to 50MPa) shows the effect of utilising high volume of POC coarse and POC powder. Substitution of 50% POC powder in place of cement can produce almost 59% of the conventional cement mortar strength which is indeed definitely satisfactory when compared on strength basis for structural application. This was also observed from the POC powder test results (as discussed in Section 5.3.3) where almost 70% of the strength can be obtained by the samples. POC powder which has a weak pozzolanacity and greater filler effect would have improved the strength achievement. Furthermore, introduction of POC aggregates (POC fine and POC coarse) as total aggregate replacement in POCON mortar can produce 80% of the strength compared to natural aggregates irrespective of cement replacement. From both types of replacements, it is evident that POC stands an innovative solution to produce a greener aggregate other than cost effective and environmental friendly.

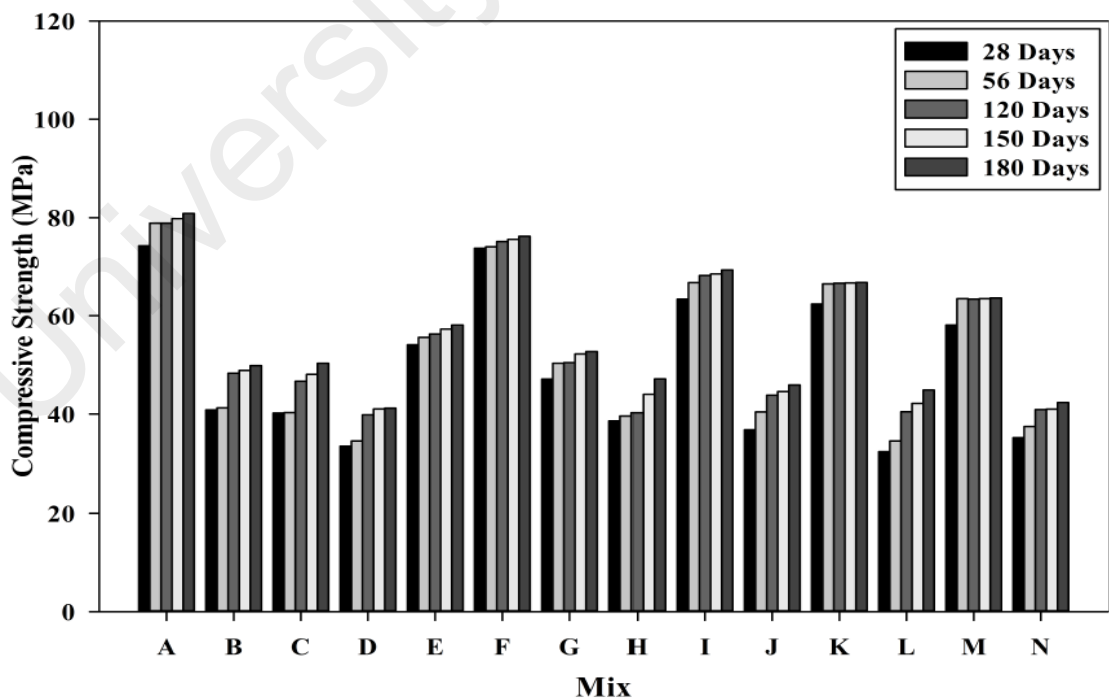

Figure 5.93: POCON mortar compressive strength

Table 5.8 tabulates the compressive load results for POCON samples. Figure 5.94 shows the load extension graph of different POCON mixes. The peak loads of all the mixes are shown on the figure. It should be noted that a minimum strength of 120kN can be achieved for all the mixes including those replaced with substantial amount of POC powder. As observed, all the mixes including with POC coarse, POC fine and POC powder showed similar load pattern indicating the effectiveness of using POC material in this structural element. As expected, mix A with only sand and cement performed well in taking up huge amount of load. This could be due to the presence of maximum cement content in addition to the availability of conventional aggregates. POC coarse addition in all the mixes tends to reduce the strength less than 50% of control strength. The highly porous and low strength sustaining capacity of the POC aggregates may be the reason behind this. POC fine addition in place of sand, performed almost similar compared to sand showing the high potential of the material (as described earlier in section 5.4). The strength reduction was noticed to be only about 9%, which is generally positive for a waste material inclusion.

Table 5.8: Compressive load results for POCON samples

Mix	Sand (%)	POC Fine (%)	POC Coarse (%)	Gravel (%)	Cement (%)	POC Powder (%)	Mass (kg)	Max Load (kN)
A	100	-	-	-	100	-	9.39	251.38
B	100	-	-	-	50	50	8.83	147.54
C	-	100	-	-	50	50	7.79	131.50
D	-	-	100	-	50	50	8.25	161.40
E	-	-	-	100	100	-	9.70	183.43
F	50	50	-	-	100	-	8.80	197.57
G	50	50	-	-	50	50	8.11	145.87
H	-	50	50	-	50	50	7.59	140.80
I	50	-	50	-	100	-	8.77	188.10
J	50	-	50	-	50	50	8.04	138.35
K	50	-	-	50	100	-	9.44	210.07
L	50	-	-	50	50	50	8.88	149.22
M	-	50	-	50	100	-	8.81	181.29
N	-	50	-	50	50	50	8.35	119.69

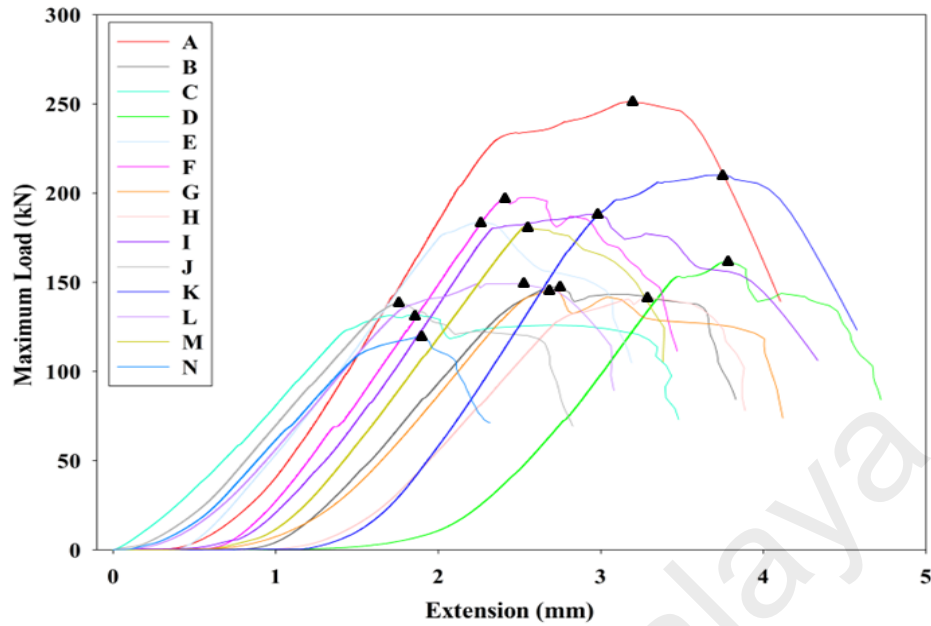

Figure 5.94: Relationship between compressive extension and compressive load

Furthermore, some of the mixes showed a longer extension period under small load increment. This perhaps could be due to the design of the POCON which is in truss shape. The truss design of POCON contains the load due the multiple way of strength transfer across the structure. This reduces the abrupt failure of POCON upon reaching the pre-maximum load which is approximately 85% of the strength is maximum load. Upon this load, the truss system helps to sustain load before failing at a higher load. Figure 5.95 shows the correlation between POCON mortar and POCON structure maximum load. This correlation serves as an indication on the possible load attainment for POCON at different replacement level. The relationship between structural efficiency and maximum load of POCON is illustrated in Figure 5.96. It is worth mentioning that inclusion of POC powder as cement substitution has the ability to produce 77% comparable structural efficiency to that of mixture without cement replacement. Above all, POC is able to produce on average about 60% to 80% of the fresh and hardened properties performance comparable to conventional concrete or mortar. It is worth noting that it has all the potential to be utilised in structural elements

with significant savings in cost and most importantly with sufficient sustainability components. Although at initial stages the tests performed were to assess the potential of the ornament as a non-structural element, results from the maximum strength retention highlight the capability of the ornament to act as a structural element.

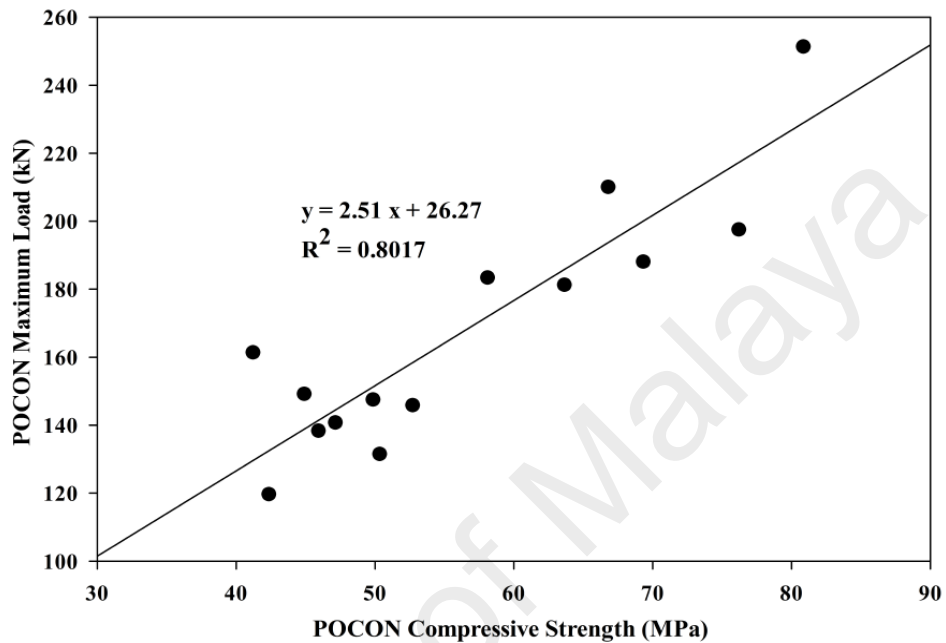

Figure 5.95: Correlation between POCON compressive strength and POCON maximum load (180 Days)

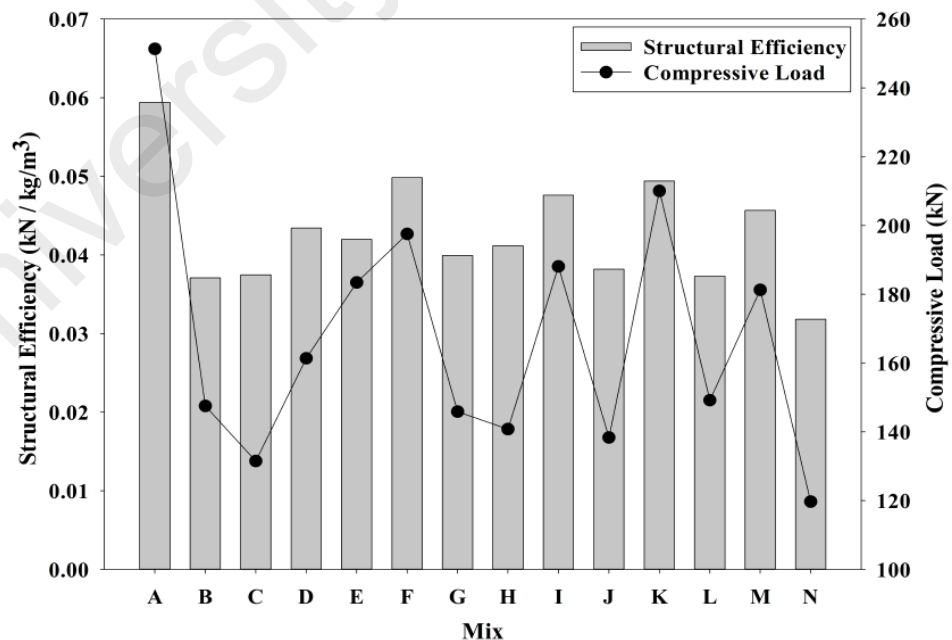

Figure 5.96: Relationship between POCON structural efficiency and compressive load for different mixes (180 Days)

CHAPTER 6: SUSTAINABILITY AND ENVIRONMENTAL ASSESSMENT

6.1 Introduction

In the past, greater emphasis has been given on green product applications which eventually help in conserving the natural resources. In tandem with that, it is imperative to study the sustainability components of using the agro-waste in concrete. It would provide a quantitative value of the advantages in using these waste products rather than allowing them to pollute our environment. Thus, a complete assessment is required to analyse the importance of recycling this waste material into construction industry which also proves to be an ideal or novel approach. The sustainability assessment is divided into five major sections which are essential to highlight the environmental and economic implications of utilising palm oil clinker (POC). They are cost analysis, greenhouse gas emission (GHG) or carbon emission, green building index (GBI), energy efficiency and life cycle assessment (LCA). The cost and GHG analysis were carried out for local POC aggregates mortar, POC powder mortar, POC fine mortar and POC concrete. GBI, energy efficiency and LCA were performed generally for POC.

6.2 Assessment of Local Palm Oil Clinker (POC) Aggregates in Mortar

Figure 6.1 shows the cost of mortar for various state samples in comparison to the control mix. As observed in Figure 6.1, the price range for POC state samples were in between 0.47 and 0.51. In comparison to control mortar specimen, on average there is an approximately 17% reduction in cost when sand is totally replaced with POC. This shows significant savings to the cost of construction on a larger scale.

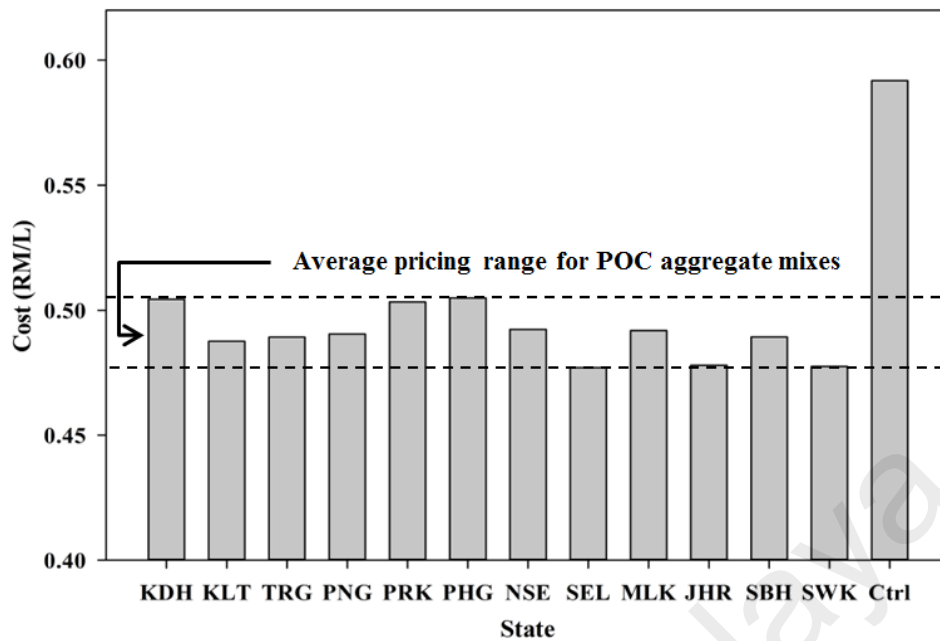

Figure 6.1: Cost of mortar incorporating local POC aggregate

Figure 6.2 shows the carbon emission and engineering environmental (EEI) value for an average content of POC fine incorporation from each state in Malaysia. Carbon emission for control samples was $0.924\text{tCO}_2\text{-e/m}^3$. Conversely, POC specimens produced emission discharge at a rate of $0.835\text{tCO}_2\text{-e/m}^3$ implying about 9.6% reductions on average. Integration of engineering elements through EEI proved to be on the positive side for POC utilisation. EEI value was improved by 17.6% compared to control specimens indicating the ability of the POC to produce substantial engineering performance without forgoing the environmental advantages. This would be a ‘win-win’ situation for most of the applications as a higher ratio of engineering to environmental component can be achieved to increase the sustainability criteria of POC use.

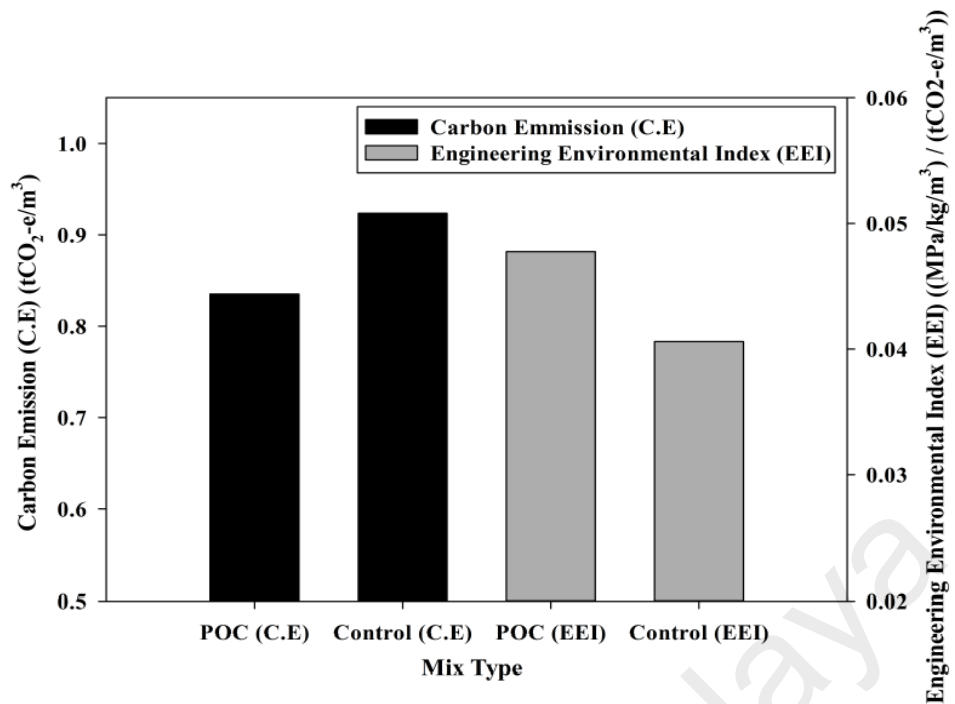

Figure 6.2: Relationship between carbon emission, mix type and engineering environmental index (EEI)

6.3 POC Powder Self-Compacting Mortar (SCM)

Figure 6.3 shows the cost effect and engineering economic index (ECI) of adding POC powder as a replacement material for cement. ECI was performed through integration between cost factor and engineering properties. It provides a good indication or medium to evaluate the positive contribution by a waste material towards the hardened mechanism besides the economic advantages. In addition to that, this index also serves as a comparison to understand the possible savings and cost cutting rate as a result of waste material utilisation. As observed from Figure 6.3, almost 41% of the cost can be reduced or saved by incorporating POC powder in concrete or mortar. Besides that, ECI value for POC 50 was also improved by 26%. As POC are obtained directly from the palm oil mill without any additional cost, it can be considered as entirely 'free' or 'zero cost' material. The cement industry is one of the largest contributors towards increasing global carbon emission. Hence, drastic actions are required to contain this problem. Use of POC powder to substitute cement would stand an innovative solution besides being environmentally sustainable. Figure 6.4 depicts the relationship between

carbon emission, POC powder replacement and EEI relationship. EEI values were enhanced by 42% when 50% POC powder was incorporated into the mix. This improvement shows the significant balance between the engineering and environmental elements upon replacement. Figure 6.5 shows the correlation between ECI and EEI. The good correlation indicates the presence of a balance between cost and environmental components when are utilised in the construction industry. Some of them do utilise them as artificial reefs to prevent spillage of their palm oil mill effluent (POME). ECI values do also provide an ‘added’ value to the global push towards green material use in construction industry. The GBI which emphasizes incorporation of some green or waste material in concrete raises the potential of using POC in concrete. It would be a step in a right direction to persuade the cement industry to look at the available agricultural waste to be used as blending materials. As majority of the blending materials such as fly-ash, ground granulated blast furnace slag (GGBS), silica fume and others are generally obtained from the industrial waste products, it would be a smart and forward thinking to introduce this waste in the cement industry.

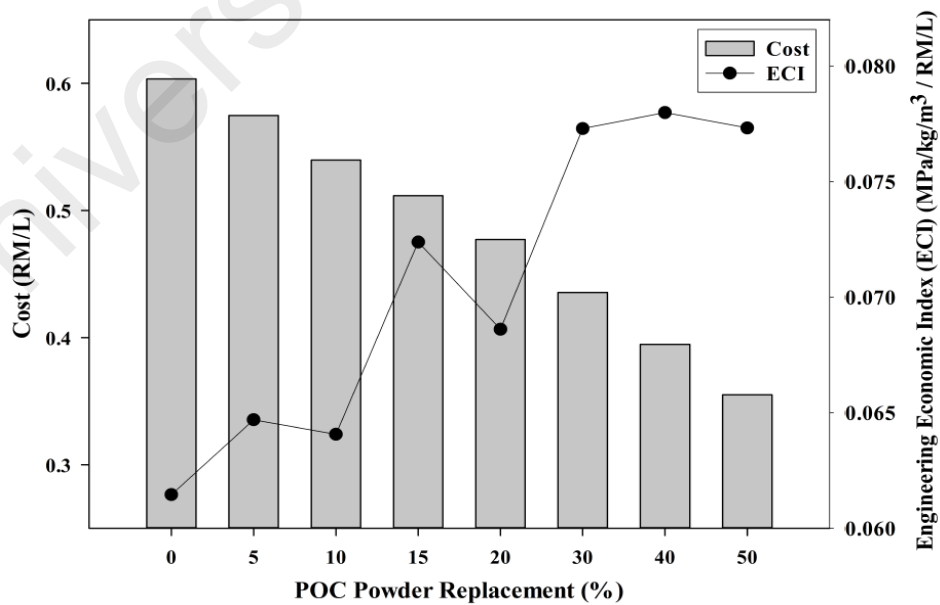

Figure 6.3: Cost comparison of specimens incorporating POC powder with engineering economic index (ECI)

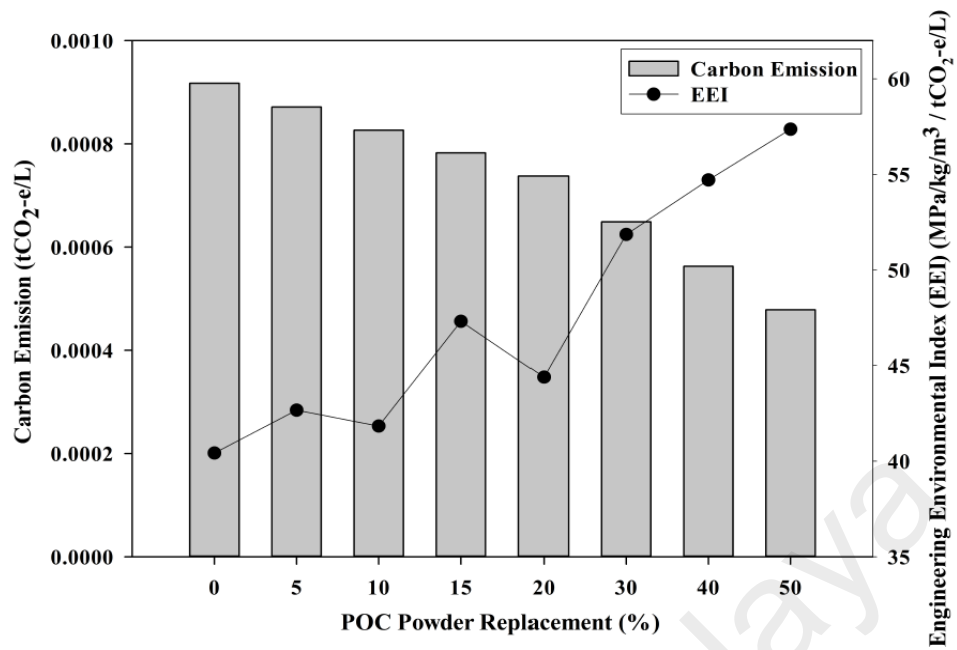

Figure 6.4: Carbon emissions of specimens incorporating POC powder with engineering environmental index (EEI)

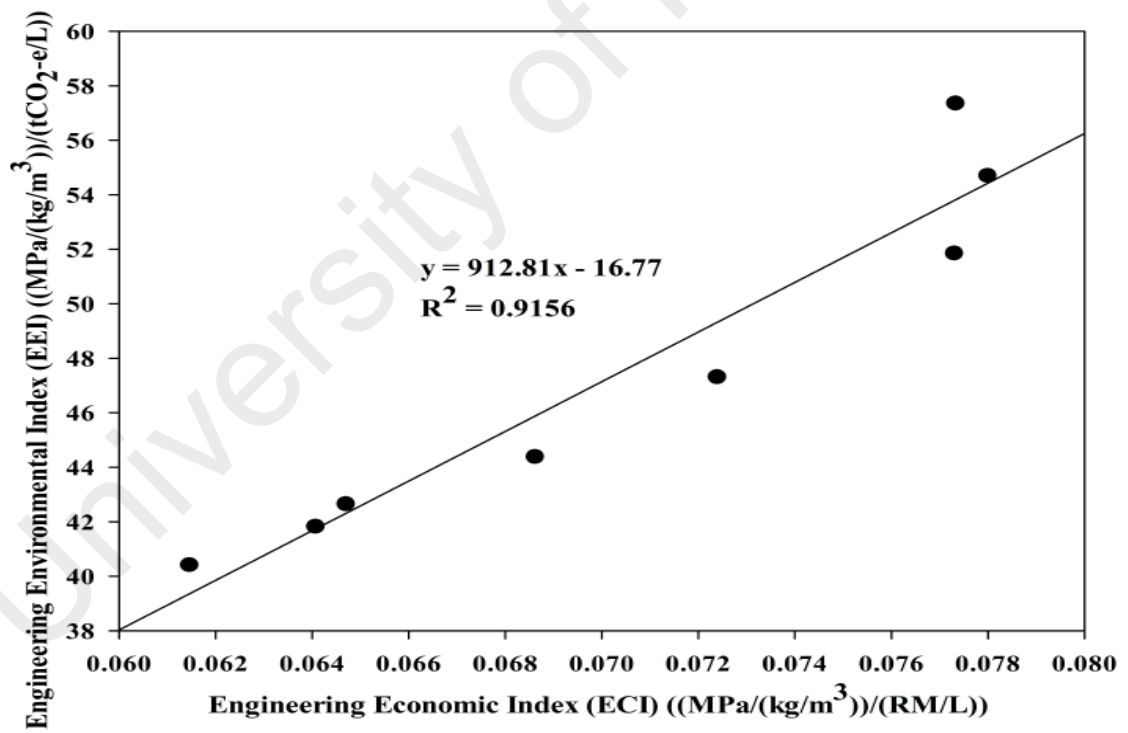

Figure 6.5: Relationship between engineering economic index (ECI) and engineering environmental index (EEI) for POC powder specimens

6.4 POC Fine SCM

Figure 6.6 shows the relationship between cost, POC fine replacement and ECI. The cost analysis is performed based on the real market price of raw materials. As observed there is a reduction of about 13% in cost when sand is totally replaced with POC fine. Although there is a small reduction in strength properties, the economical contribution by the material tends to overcome the engineering values which make it more viable for the construction industry for future. The ECI values were further enhanced as the replacement level rose indicating the high efficient correlation between strength and cost factor. Accordingly, when sand is totally replaced with POC fine the ECI index was improved by 11%. This would be a major selling point for utilising POC fine as an alternative to sand.

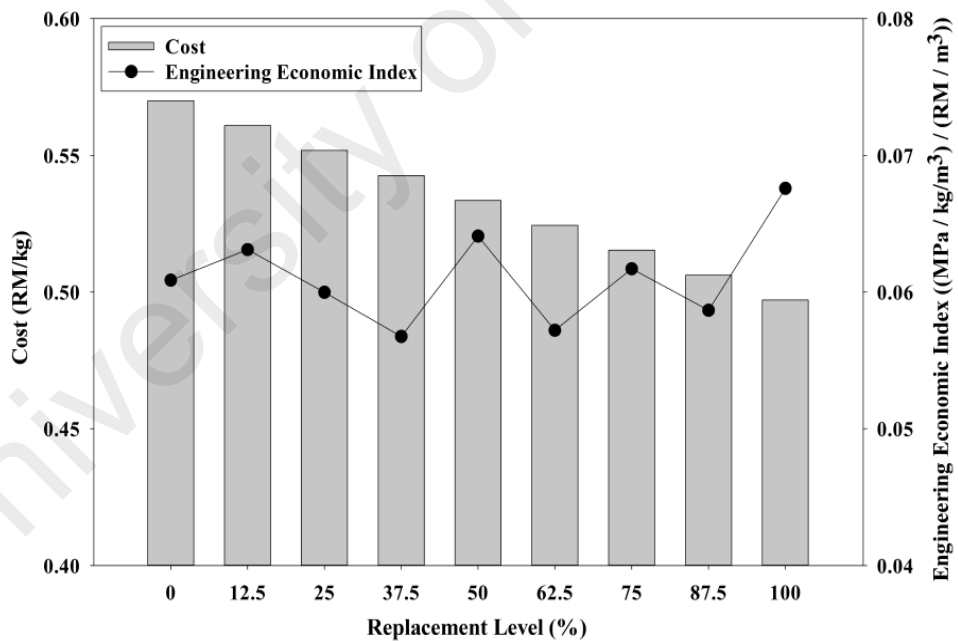

Figure 6.6: Relationship between cost, POC fine replacement and engineering economic index (ECI)

Figure 6.7 shows the relationship between GHG, POC replacement and EEI. There is a significant reduction in carbon emission of about 50% when sand was totally replaced with POC fine. EEI value correspondingly also improved substantially when sand is

totally replaced with POC fine. As this study is in line with the suggestion outlined by Meyer (2009) with regards to utilising recycled materials in concrete, this substitution will definitely promote ‘green’ concrete concept which has been emphasised over the years. The elevation in strength to carbon emission factor indicates the high efficiency of POC fine to improve the environment quality. Construction industry which is in need of material which can reduce the carbon emission and at the same time boosting up the engineering components may opt for POC fine as a solution.

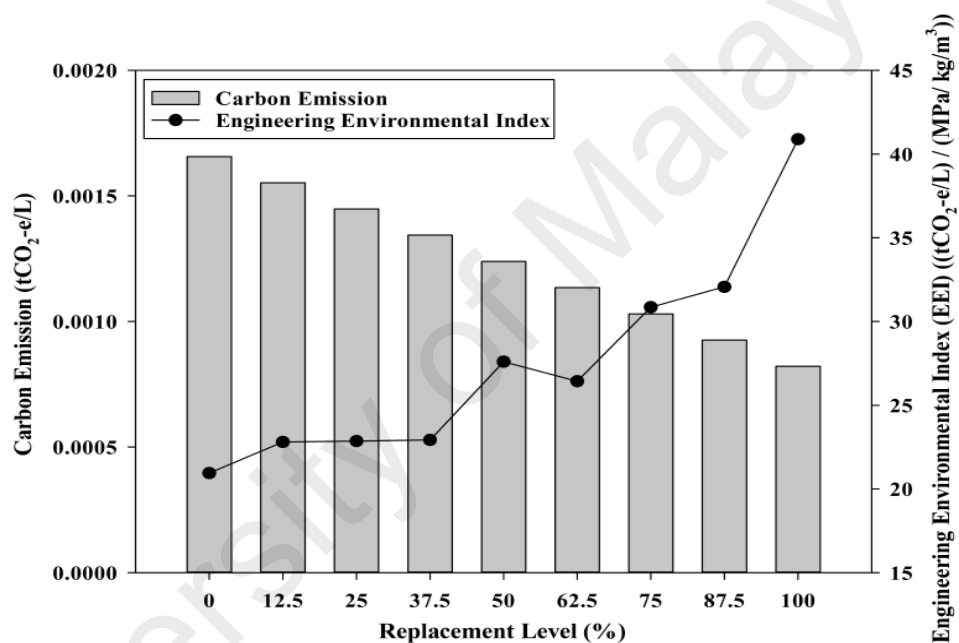

Figure 6.7: Effect of POC fine addition on carbon emission and engineering environmental index (EEI)

6.5 POC SCC

Sustainability of POC itself was assessed using GBI and LCA. The outcome of the analysis may indicate the applicability and potential of POC as a substitute for conventional aggregates. Besides that, the sustainability and environmental components of POC SCC were also determined.

6.5.1 Green Building Index (GBI)

GBI can be defined as the assessment tools used to evaluate the buildings that are designed to save resources and energy, recycled materials and reduce the amount of toxic emission throughout its service life (Mun, 2010). As GBI is becoming pertinent nowadays to improve utilisation of waste and green materials in construction industry, there is an urgent need for most of the building elements to exercise them. This would in turn provide better waste resources utilisation and management. Construction industry especially takes a larger proportion of the emissions during cement manufacturing and construction process. This cement processing stages contribute 5% to 7% of the world GHG emissions (Benhelal et al., 2013; Wang et al., 2013). This in the longer run will create an unstable environmental system which might lead to irreparable ecosystem. Hence, a drastic measure has to be undertaken to address these issues in order to ensure healthier living and atmosphere. Referring to the outlined GBI assessment criteria for various types of construction, incorporation of POC as a construction material can enhance the GBI criteria (G. B. I. Malaysia, 2011). The highly versatile POC can be used as an alternative for coarse aggregates, fine aggregates and powder materials. Table 6.1 shows the GBI points that can be collected when POC is used. It is evident that for residential new construction (RNC), non-residential new construction (NRNC) and industrial new construction (INC), the 'material resources' criteria can be fulfilled which contributes to an average of 5% (5/100 points) of the overall GBI rating system. Moreover, under 'building and resources' criteria, GBI for township construction can be improved by 3% (3/100 points) when POC is utilised. It is worth noting that POC has the ability to contribute about 5% on average to the overall GBI assessment. Future studies on the utilisation of POC especially on thermal performance and porous concrete can contribute significantly towards fulfilling other criteria such as 'energy efficiency' and 'water efficiency', respectively.

Table 6.1: POC contribution towards green building index (GBI) assessment

Type of Construction	Assessment Criteria	Available Points	Points where POC can contribute
Residential New Construction (RNC)	Material Resources	12	6
Non-Residential New Construction (NRNC)	Material Resources	11	5
Industrial New Construction (INC)	Material Resources	10	5
Township	Building and Resources	15	3

6.5.2 Cost Analysis

The rising cost of materials over the years has increased the need for substitute materials to not only bring down excessive natural resources utilisation but also to minimize cost effectiveness of the construction. Most of the construction companies nowadays are opting for low cost material without foregoing the strength properties considerably. This contributes significantly towards change in the broader perspective of the construction companies to incorporate waste materials as an addition to lower their overall cost. Over the years, self-compacting concrete (SCC) has not been a popular choice due to its high economical constraint and need of major technical alteration to mixing process. However, this can be solved with the introduction of waste material which would in turn reduce the cost of concrete (Khan et al., 2012). Figure 6.8 and Figure 6.9 show the cost of POC mixes for 0.6 F/A and 0.5 F/A respectively. By analysing the cost effectiveness of few available mixes, it was found that POC 100 mix (maximum replacement) in both cases can reduce the overall cost of concrete by 29.6% on average in comparison to control mix. This accounts up almost to one third of the construction cost. Moreover, the ECI values were substantially improved with the introduction of POC aggregates and powder. As observed from Figure 6.8 and 6.9, the

ECI values were 36% and 35% higher than control mixes for 0.6 F/A and 0.5 F/A, respectively. The availability of the POC samples plays a major role in determining the effectiveness of the investment made. It should be noted that there are 440 oil palm mills in Malaysia. On a per day basis, each mill is estimated to produce around four to five tons of POC. This sums up to an average of 1980 tons of POC production overall in Malaysia. Thus, this abundantly available material has a high economic value with sufficient production rate. The improved structural efficiency of the POC mix is certainly one of the major advantages of utilizing waste materials which contributed significantly towards greater ECI values. Furthermore, the new mix design method which incorporates the particle packing method also helps to lower down the cost of the concrete. The optimization of packing level of aggregates mixtures avoids excessive use of paste volume to substantiate the voids. In addition, instead of using any other type of powder materials, POC powder was preferred to increase the environmental value of the study which also brought down the cost substantially. Previous study conducted by Mostofinejad and Reisi (2012) also mentioned that high packing density of aggregates mixture has the capability to reduce the cost.

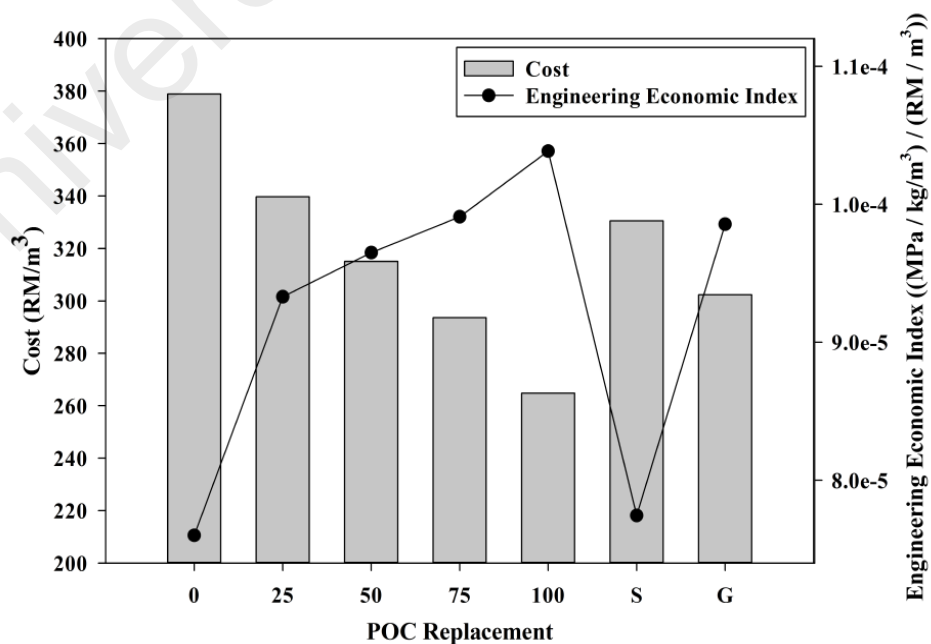

Figure 6.8: Relationship among the cost of concrete, POC replacement ratio and engineering economic index (ECI) (0.6 F/A)

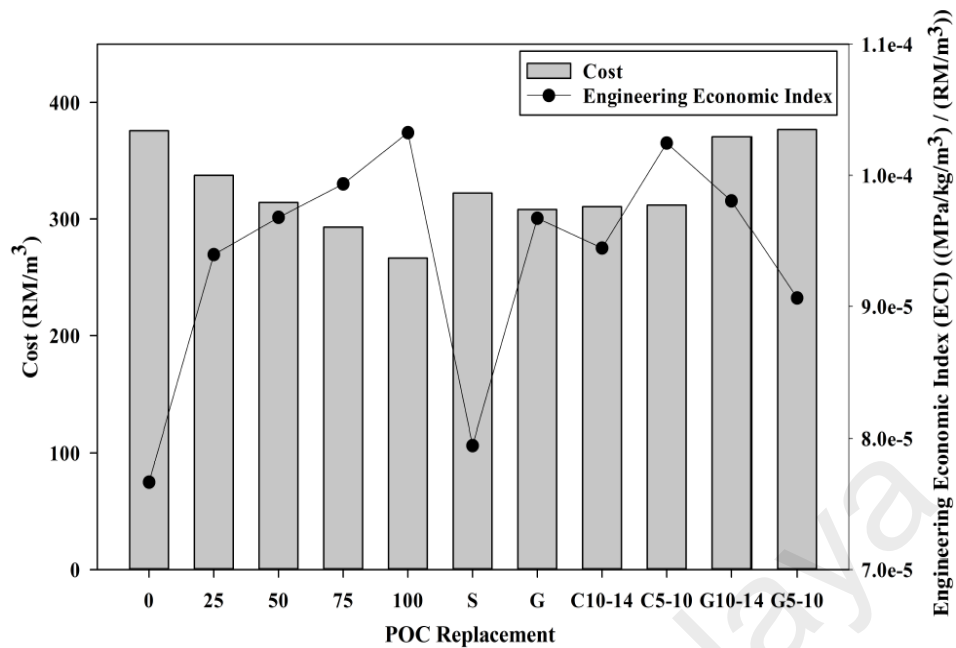

Figure 6.9: Relationship among the cost of concrete, POC replacement ratio and engineering economic index (ECI) (0.5 F/A)

Besides that, the lightweight property also provides an additional enhancement for application in construction industry. Industries such as precast, repair and rehabilitation may benefit greatly though incorporation of POC as their concern may not be for structural purpose but mainly on achieving minimal strength concrete with good structural efficiency. It was found that incorporation of POC at different levels showed greater ECI values to that of control specimens. POC 100 using maximum palm oil mill by-products produced on average 35.7% higher ECI values compared to control specimens. This is due to the lowest cost involvement and satisfactory engineering properties. While, Table 6.2 shows the comparison of POC mixes with some other mixes obtained from few other researchers (Su et al., 2001; Valcuende et al., 2012). Similar price index was adopted to evaluate the cost comparison. On a comparison basis with normal weight concrete, almost 30% of the cost can be saved with POC. This exhibits the high potential of POC to be very economical and could yield substantial profits for mass production.

Table 6.2: Mix design comparisons

Materials (kg/m³)	Conventional 1 (Su et al., 2001)	Conventional 2 (Valcuende et al., 2012)	POC 0 (0.5 F/A)	POC 100 (0.5 F/A)	POC 100 (0.6 F/A)
Sand	912	1073	765	-	-
Gravel	706	734	780	-	-
POC Fine	-	-	-	503	630
POC Coarse	-	-	-	409	341
Cement	350	-	420	420	420
POC Powder	-	-	215	388	357
GGBS ^a	61	-	-	-	-
Fly ash	142	-	-	-	-
Limestone powder	-	125	-	-	-
SP	8.80	5.70	5.40	3.64	3.50
Total Cost (RM/m³)	402.81	369.09	375.65	266.36	264.79
Total Cost (USD^b/m³)	103.82	95.13	96.82	68.65	68.24

^aGGBS – ground granulated blast furnace slag

^b1 USD = RM 3.88 (As of 1 April 2016)

6.5.3 Greenhouse Gas (GHG) Emissions

Over the past few decades, the construction industry has been trying to reduce the amount of GHG. Construction industry is one the largest contributor towards carbon emissions during processing and manufacturing stages of cement (Kajaste & Hurme, 2016). Besides that, quarries producing aggregates also tend to release small amount of emissions through processing stages. The carbon emissions were analysed taking into account the current state in the palm oil milling industry. Based on the information gathered from Malaysian Palm Oil Board (MPOB) and most of the palm oil mill managers, POC are mostly being used as pothole covers and very little being landfilled.

This limited the boundaries which were set up to study the carbon emission for POC production. POC collected from the mill for this research was completely incinerated at high temperature and was utilised as it is for concrete production. This allowed for very minimal carbon emission factor of 'zero' for POC. Besides that, POC which is much lower on weight leading to lower density increases substantially the volume of the aggregates. This could provide higher amount of POC in place of normal sand and gravel for a fixed volume. Energy savings can be enhanced significantly for mass production. The carbon emission was studied as per the information in Mineral Products Association (2012). Additional transport of materials was analysed based on DECC (2011) and was studied on per kilometer basis to ease the process of evaluation. The analysis was also carried out based each mix proportion considering the different replacement rate of POC. Figure 6.10 and Figure 6.11 show the relationship between carbon emission, POC replacement and EEI for per kilometer distance for 0.6 F/A and 0.5 F/A, respectively. A decrease of 24% and 23% in terms of carbon emissions was observed when POC was utilised at a maximum rate (POC 100) for 0.6 F/A and 0.5 F/A, respectively. EEI was evaluated through analysis on both structural efficiency and carbon emission. It should be noted that EEI values for maximum replacement level (POC 100) were enhanced by 25% and 24% for 0.6 F/A and 0.5 F/A mixes, respectively.

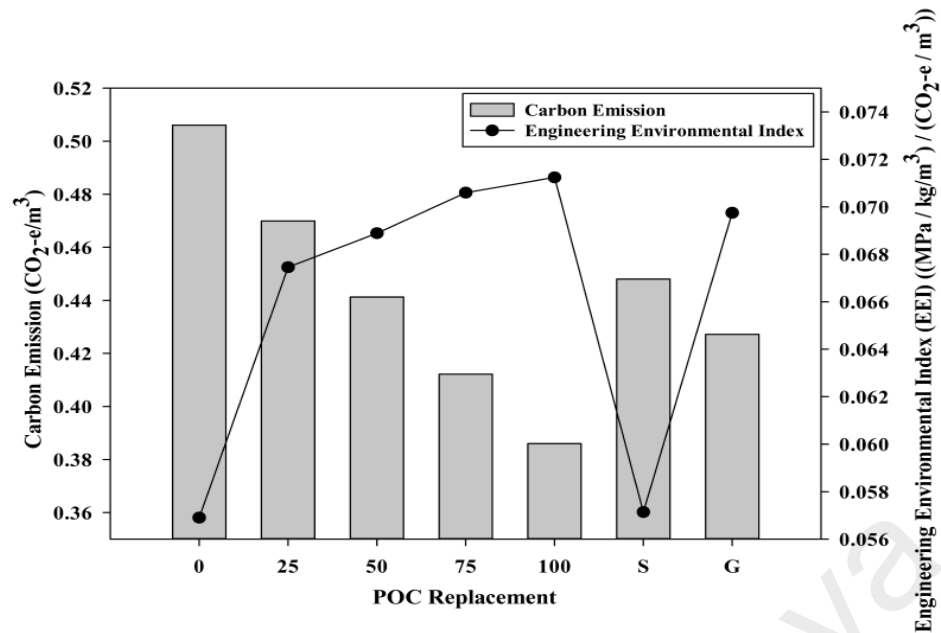

Figure 6.10: Relationship among the carbon emission, POC replacement ratio and engineering environmental index (per kilometer) (0.6 F/A)

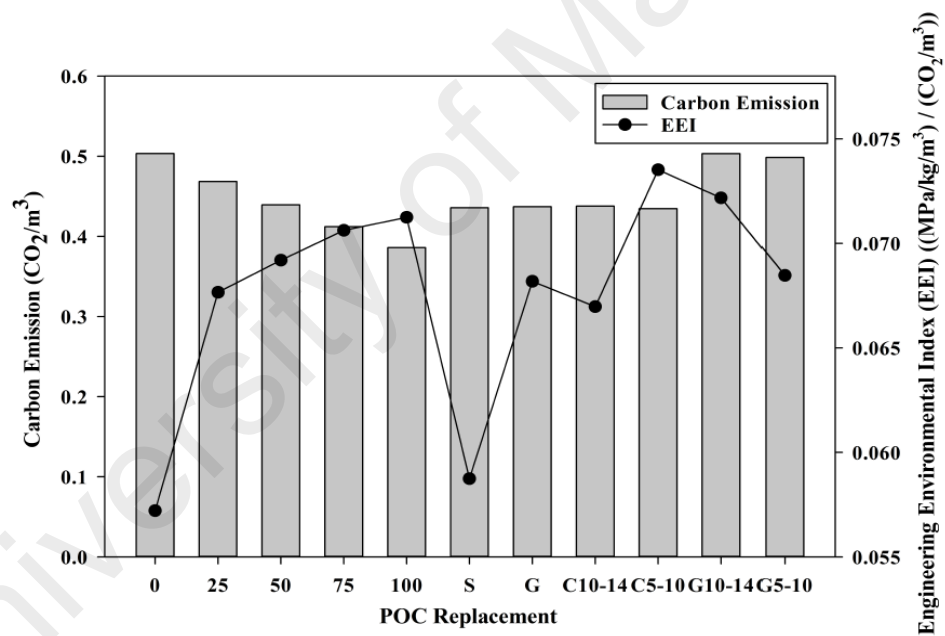

Figure 6.11: Relationship among the carbon emission, POC replacement ratio and engineering environmental index (per kilometer) (0.5 F/A)

As the use of cement was made constant, the differences in the mixes were mainly on the incorporation of POC powder and POC aggregates. These values decreased the EEI values to improve the environmental stand with respect to that engineering property of the mixes. Introduction of POC powder to satisfy the need for an extra paste for PP method of mix proportioning helped further to lower down the EEI values. Although

some other type of waste or industrial material such as fly ash, silica fume, GGBS and limestone powder can be used for this purpose, POC was still used instead to maximize this palm oil mill waste. For an example, almost 434 kg/m^3 of cement would be required to supplement the need of extra paste for POC 100 (0.6 F/A) mix. However, use of excessive cement was tackled by utilizing POC powder. Through this a significant discharge of carbon dioxide to the environment can be prevented. A 'zero' waste application method which was proposed through this study could lead to proper waste management system.

Figure 6.12 shows the correlation between carbon emission and cost. This analysis would indicate the ideal sustainability relationship as it connects the cost and carbon emission together. As observed, high cost factor contributed by the presence of natural resources such as cement, gravel and sand also correspondingly produced higher carbon emission. Utilisation of POC helped to produce lower cost cum lower carbon emission which is substantial improvement in the sustainability properties. As the world is seriously in need of alternative material in place of natural resources whereby the global pollution is another governing factor, POC would stand as an ideal sustainable solution. Aforementioned, quickly expanding oil palm industry in Malaysia would definitely increase the production rate of POC. Thus, channelling POC would be smart move to safeguard both the oil palm industry and construction industry greatly.

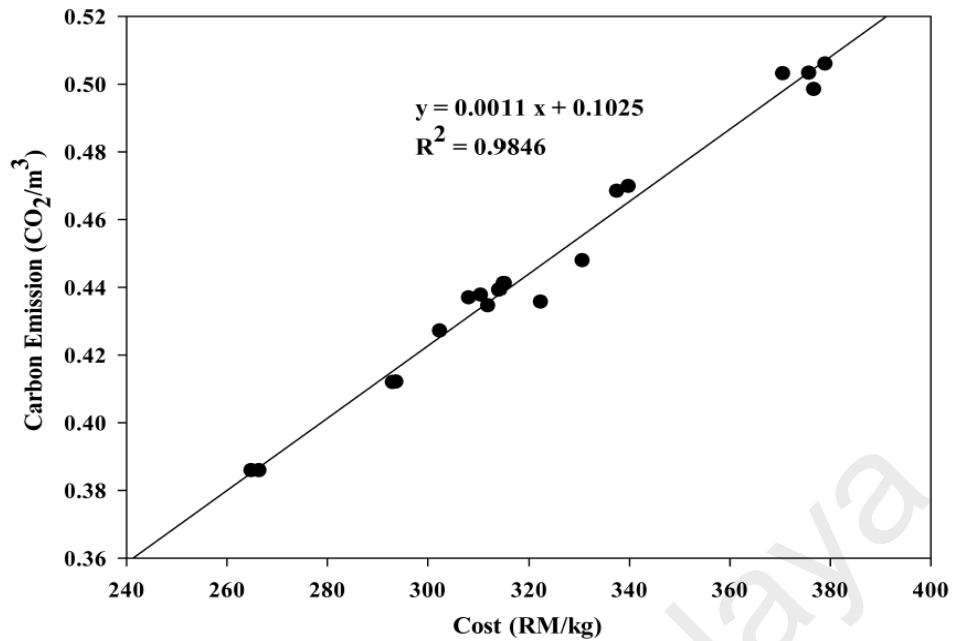

Figure 6.12: Correlation between carbon emission and cost

6.5.4 Energy Efficiency

Energy utilisation is an important aspect that needs to be given attention considering its potential to produce wastages which could be beneficial to some other industries. POC needs 3.1 times smaller energy utilisation compared to natural aggregates based on the assessment made on the aggregate crushing value (ACV) studies (as tabulated in Table 4.5). POC aggregates with immense internal pores decreases the maximum impose load required to break the aggregates apart. This in turn reduces the amount of energy required to produce the aggregates on mass basis. This leads to reduction in time, cost and labour requirement for the preparation of POC aggregates. Faster crushing process may be able to bring down machine running time to speed up construction schedule. This will result in substantial energy consumption to save significant cost of electricity indirectly. Gravel which is usually very much harder and stiffer in nature needs greater amount of load to crush them physically. Large amount of energy in the form of machineries and electricity is required for the production phases of gravel in a quarry. This would also incur greater cost and GHG emission.

6.5.5 Life Cycle Assessment

A LCA was made on POC through a collaboration work with the environment group of MPOB. The inventory data used for this study based on the real data input obtained from was provided by MPOB which is kept confidential and for research use only. It is vital to evaluate them as it would provide the real on site activity or occurrence due to POC disposal besides giving the complete reason behind using them in the construction industry. As mentioned earlier by Vijaya et al. (2008), some of the palm oil mills do use that produce POC leave the waste idle on the ground at the plantation areas. As such, the damage to the environment needs be quantitatively assessed through LCA. In this study, a quantitative comparison of LCA between two different scenarios was studied. One of them is considering the situation of using POC as aggregates in the construction industry; while the other is if POC is directly landfilled or applied in plantation areas. Based on this study, POC is entirely channelled into the concrete production phase without any additional processing or modification stages. They are directly consumed in as aggregates and powder. Thus, a comparative study between dumping in the plantation area and direct consumption in concrete will be investigated thoroughly.

The evaluation process was carried out on a gate to gate boundary basis to understand the effect of only POC to the environment. It comprises of system boundary which begins at the fresh fruit bunch (FFB) hopper till the production process of crude palm oil (CPO) where biogas are collected. The assessment was made on SimaPro (System for Integrated Environmental Assessment of Products) Software Version 8.01 and Eco-Indicator 99 methodology. The functional unit was based on per ton of CPO production. Figure 6.13 shows the weighted life cycle inventory assessment (LCIA) for two different scenarios stated earlier. Six different categories of environmental assessment were performed to evaluate the environmental effectiveness and benefits of using POC; respiratory organics, respiratory inorganics, climate change, ecotoxicity,

acidification/eutrophication and fossil fuels. It is clear that only the ecotoxicity impact was greatly affected as a result of POC utilisation in concrete. Ecotoxicity component plays a vital role in modelling the ecosystem quality damages due to certain changes to the environment. Presence of certain metal traces such as aluminium (Al) and magnesium (Mg) may give significant changes to the soil structure. For instance, aluminium a heavy metal may cause damage to the plant roots besides affecting the intake of necessary nutrients such as magnesium and potassium (Reis, 2005). When they are in contact with ground, there is a possibility of inducing leachates formation. A weighted toxic stress impact of about 6.83 Pt was recorded when POC are dumped on land as a disposal alternative. Besides that, on a longer run these metal traces may cause pollution to the groundwater supply as the leachates could infiltrate. While analysing the other scenario, it was found that if POC are incorporated into the building industry as aggregates and supplementary binder materials, they would only produce 0.003 Pt which is about 99.96% savings. It proves that POC serves for a good purpose to reduce the negative impact to the soil besides providing a suitable disposal alternative to the palm oil mill industry. In addition, the construction industry do gain significant benefits by getting a new lightweight material and additional binding agents in place of normal aggregates and cement respectively.

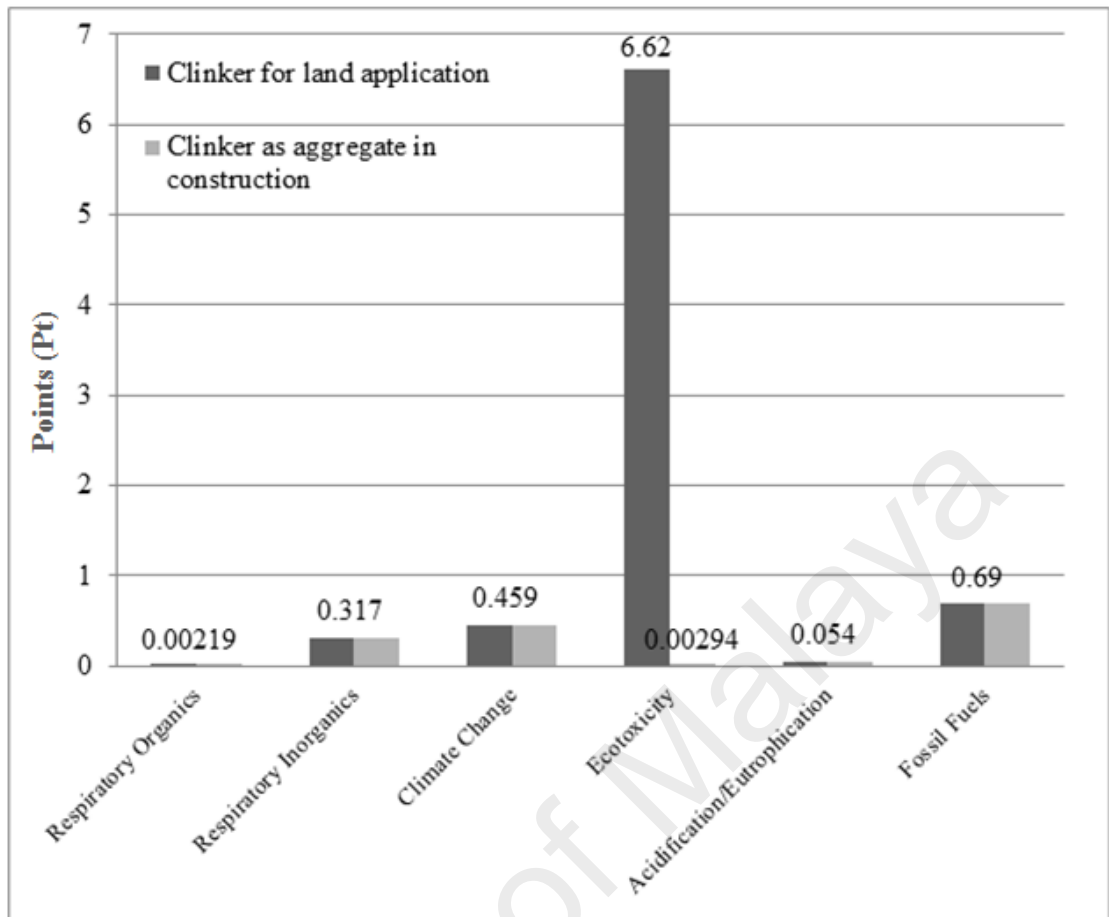

Figure 6.13: Comparison of weighted LCIA for 1 ton CPO when POC was used for land application versus when used in the construction industry

CHAPTER 7: CONCLUSIONS

7.1 Conclusions

This study is aimed on conducting a complete research on palm oil clinker (POC), a waste from the palm oil mill production stages to be incorporated in concrete for structural and other applications. As it would be the first and novel study on the utilisation of POC in concrete, deeper and complete characterisation studies were required. The feasibility of the material was completely determined to evaluate the possible variations and the causes. Firstly, the samples throughout Malaysia were collected to observe the variations among the samples in terms of chemical and physical properties. It was found that the chemical and physical properties were almost similar and consistent indicating small variance between the samples. Specifically, it was found that,

- The average compressive strength and density of POC from all states in Malaysia were 86.4 MPa and 2166 kg/m³, respectively which are approximately similar to the control mix (Figure 5.4).
- Despite being lightweight aggregates, complete replacement of sand with POC fines managed to produce 0.037 MPa/kg/m³ mean structural efficiency value which is about 98% compared to control mortar (Figure 5.5). The compressive strength and flexural strength reduction were only about 9% and 5%, respectively.

This exhibits that POC can be used as aggregate replacement material in the construction industry. This pioneer finding was an important breakthrough for the Malaysian palm oil sector as it provides an idea of utilising these abundantly available materials. In addition, the outcome of this feasibility study could also create a new

commercial bridge between the palm oil and construction industry to initiate a possible path to fully reuse the material.

Taking into account the particle shape and characteristics of POC, a new mix design method was proposed based on the particle packing (PP) concept. The PP method provided a good indication to evaluate the effective void present between the aggregates. This gave a new breakthrough in designing a new mix proportion for self-compacting concrete (SCC) besides satisfying EFNARC (2005) requirements. Technically, the developed simple proportioning method not only contributed to the SCC research but also assist the construction industry to practically apply them on site for any other types of aggregates.

Introduction of POC as coarse aggregates, fine aggregates and powder brought a new dimension towards production of lightweight concrete properties due to its versatility. Significant improvements were noted on the mechanical and engineering properties of POC powder mortar, POC fine mortar and POC concrete. Although an increase in POC proportion reduced the strength of the concrete, almost 60% to 70% of the strength can be gained compared to control mix. This was made possible through the right optimised PP and void ratio to achieve the real packing level of the mixture. Although a variation in the strength properties (compressive strength, splitting tensile, modulus of elasticity) are observed, generally the concrete very much satisfied the minimum requirement for construction purposes. Further improvement or modification can be done to POC in future to minimize the variation. A 'green' concept concrete satisfying the minimum structural requirements can be obtained which is suitable on-site application. From engineering perspective of view, incorporation of POC has the ability to produce on par performance compared to ordinary concrete whereby,

- Replacement of cement with POC powder managed to produce mortar with almost 70% compressive and flexural strength compared to control mortar (Figure 5.15). Structural efficiency showed only 26% decrease when POC powder is incorporated.
- Study on POC fine mortar showed that almost 86% of the strength can be achieved with complete replacement of sand (Figure 5.28). The structural efficiency value was only 3.2% lower compared to the control specimen.
- The compressive strength of POC concrete at various replacement levels exceeded 45 MPa and 60 MPa at 28 days and 180 days respectively (Figure 5.57 and Figure 5.58). Compared to control concrete, the reduction in strength of maximum POC replaced concrete was about 25% on average at all ages. This clearly indicates the suitability of POC to replace natural aggregates as lightweight aggregates for mass concreting works.
- Only 19% reduction in tensile strength on average was observed with full substitution of POC with normal aggregates (Figure 5.60 and Figure 5.61). Despite creating a plane failure across the concrete, the strength was still within the reach of conventional concrete.
- The flexural strength of concrete improved significantly at later ages to produce only slight decrease at 180 days of testing (Figure 5.66 and Figure 5.67). It shows the ability of POC to be used as aggregates for structural components such as beams and cantilever sections.
- Modulus of elasticity was reduced by 50% at 180 days when POC is replaced with normal aggregates (Figure 5.72 and Figure 5.73).
- Structural efficiency value for mix with total POC substitution was 85% in contrary of control mixture (Figure 5.75 and Figure 5.76).

From durability point of view, definitely POC concrete stands on the positive side to provide sustainable cum long lasting product for use in various sectors. The service life of a concrete material is important to ensure the maximum utilisation of building components. POC tested under different rigid environments showed minimum changes on the deterioration or degradation side indicating suitability and use ability of the material in construction industry. Under severe conditions of sulfate, the concrete and mortars with POC addition were still able to produce satisfactory results. It is evident that POC inclusion managed to produce good durability criteria;

- All the samples produced “very low” category of chloride penetration rate even with significant higher volume POC replacements which indicates the adaptability of the aggregates and POC powder specimens in concrete (Figure 5.87 and Figure 5.88).
- Water absorption rate increased when POC is substituted with normal aggregates (Figure 5.85 and Figure 5.86). However, all the samples showed absorption rate within the stipulated or allowable range.
- The sulfate attack study confirms that POC inclusion enhanced the resistance of concrete (Figure 5.80).
- Sorptivity values were higher for POC incorporated samples confirming the availability of significant capillary pores and absorption criteria of the paste and aggregate itself (Figure 5.89 and Figure 5.90).
- Strength improvement was noticed for all samples at 250°C, and the strength loss beyond 250°C was lower for higher replacement of lightweight POC aggregate samples for 0.6 F/A and 0.5 F/A (Figure 5.81).

Use of POC contributed substantially towards the sustainability, environmental assessment and cost efficiency components. Environmentally, when 1 m³ of POC is

consumed in the construction industry as aggregates and powder materials, equivalent 1 m³ of soil can be spared from being landfilled which could prevent soil pollution. POC powder which is consumed instead of cement or other powder material to supplement the additional paste volume provided an alternative solution to reduce the discharge of dangerous carbon dioxide (CO₂) into the environment which also proves to be economically efficient. The relationship between engineering environmental index (EEI) and engineering economic index (ECI) provided an insight to the balance between the engineering, environment and cost efficiency which highlights the advantages of POC incorporation. Moreover, as POC could be used as aggregates and cement replacement material, it stands a good chance of collecting higher green building index (GBI) points to promote sustainability. The sustainability studies were performed through three vital evaluation which include greenhouse gas emission (GHG) emission, cost factor and energy efficiency. From this study, it was found that;

- Addition of POC fine as a replacement material for sand, managed to produce 18% and 9% savings in terms cost and carbon emission, respectively (Figure 6.6).
- Incorporation of POC powder can produce 52% carbon emission reduction when compared to control specimens. EEI value for maximum POC replacement was improved by 42% at 50% powder replacement (Figure 6.4). 41% of cost can be lowered with 50% substitution of cement with POC powder. ECI value was improved by 26% consequently (Figure 6.3).
- POC concrete specimens produced 30% on average savings on cost for maximum POC replacement. Carbon emission showed substantial improvement whereby almost 24% of emission can be reduced with POC substitution (Figure 6.8 and Figure 6.9).

- The highly versatile POC can improve the overall GBI for ‘material and resource’ category by almost 4% for residential new construction (RNC), non-residential new construction (NRNC) and industrial new construction (INC). GBI for township construction can be enhanced by 3% when POC is incorporated (Table 6.1).
- Life cycle assessment carried out on POC sample which was the first to be conducted throughout Malaysia showed substantial improvement on the ecotoxicity implications (Figure 6.13). As the by-product is channelled directly into the construction industry, land or soil can be spared from being polluted. The collaboration work between Malaysian Palm Oil Board (MPOB) and this research proves to give interesting discoveries which are helpful not only for the agricultural industry but also the building industry.

Development of products or prototypes for commercial use is another vital aspect of the research that meets the ‘research leading to products’ concept. Substitution of POC in palm oil ornament (POCON) and palm oil clinker drain (POCDRA) would certainly help the society in two ways; reducing waste management problems to dispose POC and introduction of novel structural elements that meets the higher strength criteria. In this study, POCON was developed and tested to be used as ornamental item for low cost housing and buildings. Introducing POC as a concreting material would substantially help the middle and low income group to own their own house as the price of the house can be lowered significantly. From the analysis of the results it is evident,

- Despite replacing cement and normal aggregates, all the POC mixes produced a minimum of 120 kN of maximum load, which is approximately 48% that of control sample (Figure 5.94).

- POCON samples incorporating POC powder has the ability to produce almost 59% of the load carrying capacity compared to control specimen.

7.2 Recommendation for Future Study

A further study is required to assess the other important potential of the material in concrete. PP method of mix proportioning can be further expanded to design conventional concrete as the mix design is flexible to suit any types of aggregate and cementitious materials. On top of that, the optimised paste and aggregate content would impart great savings in terms of cost and sustainability features of the concrete besides enhancing the hardened properties of the concrete. Thermal conductivity of the material is an important field of study that will help to further clarify the ability of the material to act as a fire insulator material in concrete in addition to elevated temperature test. The bonding properties of SCC incorporating POC would be another interesting aspect that can be explored. A 'pull-out' test can be carried out to ascertain the ability of the concrete especially with maximum POC replacement to produce sufficient bond strength. Last but not least, the commercial applications designed and tested can be applied on site to evaluate the real life structural loadings. Moreover, POCDRA samples can be applied on site to avoid serious deteriorations of drains due to the acidic nature of soil at Borneo states (Sabah and Sarawak).

7.3 Contribution to the Society

The major contribution of the study would be an introduction of a new type of local waste material from the palm oil industry to be utilised in construction industry. Looking at currently depleting natural resources, utilisation of these by-products would enhance the sustainability of the construction industry for future use. Besides that, palm oil milling industry would benefit greatly from the integration of POC in concrete as they could channel the by-products appropriately without environmental pollution. This

research would stand as an 'environmental bridge' between construction industry and palm oil industry for better management of waste and introduction of new 'green' products. The collaboration works carried out with the palm oil mill in each state in Malaysia together with MPOB have created a new wave towards initiating a novel use for POC. This research work indeed has paved a way to MPOB initiate an exploratory study to recycle POC which thought to be worthless. Parallel with global idea or push towards integration of natural materials in construction industry, this would a step in the right direction.

In addition, analysing the situation from the construction industry point of view, there are numerous research works carried out to reduce the dangerous carbon emissions originating from the palm oil industry. In this study, POC powder was also investigated for its suitability to be incorporated as extra binder agents to avoid excessive use of cement. It has been a corporate responsibility to ensure that the dangerous emissions due to cement production stages are brought down significantly. POC powder and aggregate could stand as a new blending material to reduce the greenhouse gas emissions. There is a possibility of creating a commercial product for in-house application at oil palm mills or surrounding areas to reduce the cement intake. Simple mixing for non-structural use which may need minimum cement content may be combined with POC powder. This in turn would provide good cost and material savings. POC which was characterized throughout Malaysia indicate applicability of the material in cement based materials. Results of all states were within a similar range and produced consistent results indicating enhanced feasibility of the materials to be utilised in concrete. Respective palm oil mills in each state could benefit through this study whereby abundantly available POC can be channeled to the building or cement manufacturing plants for further use. It would also benefit the palm oil mills as the concreting works for minor repairs and modifications can be incorporated with POC

aggregates and POC powder. This would in turn provide a path for proper waste management system besides cutting maintenance cost drastically.

Finally, the development of new commercial products incorporating this waste material would add an engineering and environmental value to benefit the construction industry. The substantial savings in terms of cost makes the product to be viable for use in low cost housing scheme without forgoing the engineering and mechanical properties. From this study, it is expected that further research would be carried out by oil palm mills to use them for their onsite construction purposes. Direct involvement of POC to build structural elements indicates the positive contribution by this research towards not only the palm oil industry but also construction industry. In this research the introduction of two final commercial applications (POCON and POCDRA) which were tested for structural and severe environmental conditions performed on par with any other normal weight concrete elements indicating the suitability of using POC in concrete. Reduction in environmental emissions increases the feasibility of the material to be utilised as a 'green' construction material which enhances the GBI. The fourth point of the GBI assessment tools which is 'Materials and Resources' category can be satisfied through incorporation of POC. Major Malaysian based construction conglomerates may have an alternative on using a 'green' material which can provide good EEI and ECI values. As of this perspective of view, it stands as a good concreting material which totally avoids waste from the palm oil milling industry. This study led to discovery of many unknown information previously on POC which is easily available throughout Malaysia which definitely pave the way to safeguard the wellbeing of the nature and construction industry in the long run to come in the country.

REFERENCES

- Abd. Aziz, F. N. A., Bida, S. M., Nasir, N. A. M., & Jaafar, M. S. (2014). Mechanical properties of lightweight mortar modified with oil palm fruit fibre and tire crumb. *Construction and Building Materials*, 73(0): 544-550.
- Abdul Razak, H., Chai, H. K., & Wong, H. S. (2004). Near surface characteristics of concrete containing supplementary cementing materials. *Cement and Concrete Composites*, 26(7): 883-889.
- Abdullah, N., & Sulaiman, F. (2013). The Oil Palm Wastes in Malaysia.
- Abouhussien, A. A., Hassan, A. A. A., & Ismail, M. K. (2015). Properties of semi-lightweight self-consolidating concrete containing lightweight slag aggregate. *Construction and Building Materials*, 75: 63-73.
- ACI 211.1-91. (1991). *Standard Practice for Selecting Proportions for Normal, Heavyweight, and Mass Concrete*. Paper presented at the American Concrete Institute.
- Adjoudj, M. h., Ezziane, K., Kadri, E. H., Ngo, T.-T., & Kaci, A. (2014). Evaluation of rheological parameters of mortar containing various amounts of mineral addition with polycarboxylate superplasticizer. *Construction and Building Materials*, 70: 549-559.
- Aggarwal, Y., & Siddique, R. (2014). Microstructure and properties of concrete using bottom ash and waste foundry sand as partial replacement of fine aggregates. *Construction and Building Materials*, 54: 210-223.
- Ahmad, H., Hilton, M., Mohd, S., & Mohd Noor, N. (2007). Mechanical properties of palm oil clinker concrete.
- Ahmad, I., & Azhar, S. (2004). Temperature variation in high slump drilled shaft concrete and its effect on slump loss. *Cement and Concrete Research*, 34(2): 207-217.
- Ahmmad, R., Jumaat, M. Z., Bahri, S., & Islam, A. B. M. S. (2014). Ductility performance of lightweight concrete element containing massive palm shell clinker. *Construction and Building Materials*, 63: 234-241.
- Akram, T., Memon, S. A., & Obaid, H. (2009). Production of low cost self compacting concrete using bagasse ash. *Construction and Building Materials*, 23(2): 703-712.

- Al-Jabri, K., Baawain, M., Taha, R., Al-Kamyani, Z. S., Al-Shamsi, K., & Ishtieh, A. (2013). Potential use of FCC spent catalyst as partial replacement of cement or sand in cement mortars. *Construction and Building Materials*, 39: 77-81.
- Al-Tayeb, M. M., Abu Bakar, B. H., Ismail, H., & Akil, H. M. (2013). Effect of partial replacement of sand by recycled fine crumb rubber on the performance of hybrid rubberized-normal concrete under impact load: experiment and simulation. *Journal of Cleaner Production*, 59(0): 284-289.
- Alduaij, J., Alshaleh, K., Naseer Haque, M., & Ellaithy, K. (1999). Lightweight concrete in hot coastal areas. *Cement and Concrete Composites*, 21(5-6): 453-458.
- Ali, M. B., Saidur, R., & Hossain, M. S. (2011). A review on emission analysis in cement industries. *Renewable and Sustainable Energy Reviews*, 15(5): 2252-2261.
- Alwaeli, M., & Nadziakiewicz, J. (2012). Recycling of scale and steel chips waste as a partial replacement of sand in concrete. *Construction and Building Materials*, 28(1): 157-163.
- Amrutha, N. G., Narasimhan, M. C., & Rajeeva, S. (2011). Chloride-ion impermeability of self-compacting high volume of fly ash concrete mixes. *International Journal of Civil & Environmental Engineering IJCEE-IJENS V*, 11(4): 29-35.
- Andiç-Çakır, Ö., & Hızal, S. (2012). Influence of elevated temperatures on the mechanical properties and microstructure of self consolidating lightweight aggregate concrete. *Construction and Building Materials*, 34: 575-583.
- Andrade, C. (1993). Calculation of chloride diffusion coefficients in concrete from ionic migration measurements. *Cement and Concrete Research*, 23(3): 724-742.
- Andrade, C. (2004). *Calculation of initiation and propagation periods of service life of reinforcements by using the electrical resistivity*. Paper presented at the International RILEM Symposium on Concrete Science and Engineering: A Tribute to Arnon Bentur.
- Anil Dogan, U., BORA KURT, E., Görkem Saran, A., & Hulusi Ozkul, M. (2009). Benchmarking concretes with pozzolanic materials in terms of rapid chloride penetration test. *ACI Materials Journal*, 106(3): 251-257.
- Anon, O. (1979). Classification of rocks and soils for engineering geological mapping, Part 1—Rock and soil materials. *Report of the commission of engineering geological mapping, bulletin international association of engineering geology*, 19: 364-371.

- Anwar Hossain, K. M. (2004). Properties of volcanic pumice based cement and lightweight concrete. *Cement and Concrete Research*, 34(2): 283-291.
- Ariöz, Ö., Tuncan, A., Tuncan, M., Kavas, T., Ramyar, K., Kılınc, K., & Karasu, B. (2009). Use of Combined Non-Destructive Methods to Assess the Strength of Concrete in Structures. *Afyon Kocatepe Üniversitesi Fen Ve Mühendislik Bilimleri Dergisi*, 9(3): 147-154.
- AS 3600. (2004). AS 3600 Concrete structures-incorporating AMD 1: May 2002 and AMD 2: 2004.
- Aslam, M., Shafiqh, P., & Jumaat, M. Z. (2016). Drying shrinkage behaviour of structural lightweight aggregate concrete containing blended oil palm bio-products. *Journal of Cleaner Production*, 127: 183-194.
- ASTM C140. (2015). Standard Test Methods for Sampling and Testing Concrete Masonry Units and Related Units *ASTM C140M-15*. Annual Book ASTM Standard 04.05.
- ASTM C150. (2012). Standard Specification for Portland Cement *ASTM C150-12*. Annual Book ASTM Standard 04.01.
- ASTM C348. (2014). Standard Test Method for Flexural Strength of Hydraulic-Cement Mortars *ASTM C348-14*. Annual Book ASTM Standard 04.01.
- ASTM C618. (2015). Standard Specification for Coal Fly Ash and Raw or Calcined Natural Pozzolan for Use in Concrete *ASTM C618-15*. Annual Book ASTM Standard 04.01.
- ASTM C1202. (2012). Standard Test Method for Electrical Indication of Concrete's Ability to Resist Chloride Ion Penetration *ASTM C1202-12*. Annual Book ASTM Standard 04.01.
- Atzeni, C., Massidda, L., & Sanna, U. (1986). Relationship between rheology and workability of cement mixes containing blast furnace slag. *Silicates Industriels*, 51(1-2): 5-9.
- Awal, A. S. M. A., & Shehu, I. A. (2015). Performance evaluation of concrete containing high volume palm oil fuel ash exposed to elevated temperature. *Construction and Building Materials*, 76(0): 214-220.
- Awalludin, M. F., Sulaiman, O., Hashim, R., & Nadhari, W. N. A. W. (2015). An overview of the oil palm industry in Malaysia and its waste utilization through

thermochemical conversion, specifically via liquefaction. *Renewable and Sustainable Energy Reviews*, 50: 1469-1484.

Baeza-Brotons, F., Garcés, P., Payá, J., & Saval, J. M. (2014). Portland cement systems with addition of sewage sludge ash. Application in concretes for the manufacture of blocks. *Journal of Cleaner Production*, 82: 112-124.

Barbhuiya, S. (2011). Effects of fly ash and dolomite powder on the properties of self-compacting concrete. *Construction and Building Materials*, 25(8): 3301-3305.

Bartos, P. European Union Growth Contract No: G6RD-CT-2001-00580. Measurement of Properties of Fresh Self-Compacting Concrete. Final Report September 2005. Available online at: <http://www.civeng.ucl.ac.uk/research/concrete/Testing-SCC/> (last accessed May 2007).

Basar, H. M., & Deveci Aksoy, N. (2012). The effect of waste foundry sand (WFS) as partial replacement of sand on the mechanical, leaching and micro-structural characteristics of ready-mixed concrete. *Construction and Building Materials*, 35: 508-515.

Basiron, Y. (2007). Palm oil production through sustainable plantations. *European Journal of Lipid Science and Technology*, 109(4): 289-295.

Basiron, Y., & Simeh, M. A. (2005). Vision 2020-the palm oil phenomenon. *Oil Palm Industry Economic Journal*, 5(2): 1-10.

Bazant, Z. P., & Pfeiffer, P. A. (1987). Determination of fracture energy from size effect and brittleness number. *ACI Materials Journal*, 84(6).

Behfarnia, K., & Farshadfar, O. (2013). The effects of pozzolanic binders and polypropylene fibers on durability of SCC to magnesium sulfate attack. *Construction and Building Materials*, 38: 64-71.

Ben Fraj, A., Kismi, M., & Mounanga, P. (2010). Valorization of coarse rigid polyurethane foam waste in lightweight aggregate concrete. *Construction and Building Materials*, 24(6): 1069-1077.

Benabed, B., Kadri, E.-H., Azzouz, L., & Kenai, S. (2012). Properties of self-compacting mortar made with various types of sand. *Cement and Concrete Composites*, 34(10): 1167-1173.

Benhelal, E., Zahedi, G., Shamsaei, E., & Bahadori, A. (2013). Global strategies and potentials to curb CO₂ emissions in cement industry. *Journal of Cleaner Production*, 51(0): 142-161.

- Bentz, D., & Snyder, K. (1999). Protected paste volume in concrete: Extension to internal curing using saturated lightweight fine aggregate. *Cement and Concrete Research*, 29(11): 1863-1867.
- Berndt, M. L. (2015). Influence of concrete mix design on CO2 emissions for large wind turbine foundations. *Renewable Energy*, 83: 608-614.
- Bignozzi, M. C., & Sandrolini, F. (2006). Tyre rubber waste recycling in self-compacting concrete. *Cement and Concrete Research*, 36(4): 735-739.
- Bingol, A., & Gul, R. (2004). Compressive strength of lightweight aggregate concrete exposed to high temperatures. *Indian Journal of Engineering and Materials Science*, 11(1): 68-72.
- Bogas, A., Gomes, A., & Pereira, M. F. C. (2012). Self-compacting lightweight concrete produced with expanded clay aggregate. *Construction and Building Materials*, 35: 1013-1022.
- Bogas, J. (2011). Characterization of structural lightweight expanded clay aggregate concrete. *Lisbon: PhD thesis in civil engineering. Technical University of Lisbon, Instituto Superior Técnico.*
- Bogas, J. A., de Brito, J., & Cabaço, J. (2014). Long-term behaviour of concrete produced with recycled lightweight expanded clay aggregate concrete. *Construction and Building Materials*, 65: 470-479.
- Bogas, J. A., de Brito, J., & Figueiredo, J. M. (2015). Mechanical characterization of concrete produced with recycled lightweight expanded clay aggregate concrete. *Journal of Cleaner Production*, 89(0): 187-195.
- Bogas, J. A., & Gomes, A. (2015). Non-steady-state accelerated chloride penetration resistance of structural lightweight aggregate concrete. *Cement and Concrete Composites*, 60: 111-122.
- Bories, C., Aouba, L., Vedrenne, E., & Vilarem, G. (2015). Fired clay bricks using agricultural biomass wastes: Study and characterization. *Construction and Building Materials*, 91: 158-163.
- Boukendakdji, O., Kadri, E.-H., & Kenai, S. (2012). Effects of granulated blast furnace slag and superplasticizer type on the fresh properties and compressive strength of self-compacting concrete. *Cement and Concrete Composites*, 34(4): 583-590.
- BS 812-2:1995. (1995). Testing aggregates. Methods for determination of density.

- BS 812-109. (1990). Testing aggregates. Methods for determination of moisture content. London, UK.
- BS 812-110. (1990). Testing Aggregates. Methods for determination of aggregate crushing value (ACV). London, UK.
- BS 812-111. (1990). Testing Aggregates. Methods for determination of ten per cent fines value (TFV). London, UK.
- BS 812-112. (1990). Testing aggregates. Method for determination of aggregate impact value (AIV). London, UK.
- BS 882:1992. (1992). Specification for aggregates from natural sources for concrete. London, UK.
- BS EN 12390-3. (2009). Testing Hardened Concrete - Compressive Strength of Test Specimens. London, UK.
- BS EN 12390-5. (2009). Testing Hardened Concrete. Flexural strength of test specimens. London, UK. .
- BS EN 12390-6. (2009). Testing Hardened Concrete. Tensile Splitting Strength of Test Specimens. London, UK. .
- BS EN 12390-7. (2009). Testing Hardened Concrete. Density of Hardened Concrete. London, UK. .
- BS EN 12390-13. (2013). Testing hardened concrete. Determination of secant modulus of elasticity in compression. London, UK. .
- BS EN 12504-4. (2004). Testing Concrete : Determination of Ultrasonic Pulse Velocity. London, UK.
- Bui, V. K., Akkaya, Y., & Shah, S. P. (2002). Rheological model for self-consolidating concrete. *ACI Materials Journal*, 99(6).
- Calmon, J. L., Sauer, A. S., Vieira, G. L., & Teixeira, J. E. S. L. (2014). Effects of windshield waste glass on the properties of structural repair mortars. *Cement and Concrete Composites*, 53: 88-96.
- Carro-López, D., González-Fontebao, B., de Brito, J., Martínez-Abella, F., González-Taboada, I., & Silva, P. (2015). Study of the rheology of self-compacting

concrete with fine recycled concrete aggregates. *Construction and Building Materials*, 96: 491-501.

Cassar, J., & Camilleri, J. (2012). Utilisation of imploded glass in structural concrete. *Construction and Building Materials*, 29(0): 299-307.

Chai, H.-W. (1998). *Design and testing of self-compacting concrete*. University of London.

Chatveera, B., & Lertwattanaruk, P. (2011). Durability of conventional concretes containing black rice husk ash. [Research Support, Non-U.S. Gov't]. *J Environ Manage*, 92(1): 59-66.

Chen, C., Habert, G., Bouzidi, Y., & Jullien, A. (2010). Environmental impact of cement production: detail of the different processes and cement plant variability evaluation. *Journal of Cleaner Production*, 18(5): 478-485.

Chen, S.-H., Wang, H.-Y., & Jhou, J.-W. (2013). Investigating the properties of lightweight concrete containing high contents of recycled green building materials. *Construction and Building Materials*, 48: 98-103.

Chibuike, G., & Obiora, S. (2014). Heavy metal polluted soils: effect on plants and bioremediation methods. *Applied and Environmental Soil Science*, 2014.

Chidiac, S. E., & Mihaljevic, S. N. (2011). Performance of dry cast concrete blocks containing waste glass powder or polyethylene aggregates. *Cement and Concrete Composites*, 33(8): 855-863.

Choi, Y.-W., Moon, D.-J., Chung, J.-S., & Cho, S.-K. (2005). Effects of waste PET bottles aggregate on the properties of concrete. *Cement and Concrete Research*, 35(4): 776-781.

Choi, Y. W., Kim, Y. J., Shin, H. C., & Moon, H. Y. (2006). An experimental research on the fluidity and mechanical properties of high-strength lightweight self-compacting concrete. *Cement and Concrete Research*, 36(9): 1595-1602.

Choi, Y. W., Moon, D. J., Kim, Y. J., & Lachemi, M. (2009). Characteristics of mortar and concrete containing fine aggregate manufactured from recycled waste polyethylene terephthalate bottles. *Construction and Building Materials*, 23(8): 2829-2835.

Clarke, J. L. (2002). *Structural lightweight aggregate concrete*: CRC Press.

- Colombo, M., & Felicetti, R. (2007). New NDT techniques for the assessment of fire-damaged concrete structures. *Fire Safety Journal*, 42(6): 461-472.
- Committee, A. C. I. (2003). Guide for structural lightweight aggregate concrete. *American Concrete Institute Committee: Farmington Hills, MI, USA*.
- Corinaldesi, V., & Moriconi, G. (2009). Behaviour of cementitious mortars containing different kinds of recycled aggregate. *Construction and Building Materials*, 23(1): 289-294.
- Corinaldesi, V., & Moriconi, G. (2011). The role of industrial by-products in self-compacting concrete. *Construction and Building Materials*, 25(8): 3181-3186.
- Correia, J. R., Almeida, N. M., & Figueira, J. R. (2011). Recycling of FRP composites: reusing fine GFRP waste in concrete mixtures. *Journal of Cleaner Production*, 19(15): 1745-1753.
- Crossin, E. (2015). The greenhouse gas implications of using ground granulated blast furnace slag as a cement substitute. *Journal of Cleaner Production*, 95(0): 101-108.
- Cuenca, J., Rodríguez, J., Martín-Morales, M., Sánchez-Roldán, Z., & Zamorano, M. (2013). Effects of olive residue biomass fly ash as filler in self-compacting concrete. *Construction and Building Materials*, 40: 702-709.
- Cui, H., Lo, T. Y., Memon, S. A., & Xu, W. (2012). Effect of lightweight aggregates on the mechanical properties and brittleness of lightweight aggregate concrete. *Construction and Building Materials*, 35: 149-158.
- da Silva, F. M., Gachet Barbosa, L. A., Lintz, R. C. C., & Jacintho, A. E. P. G. A. (2015). Investigation on the properties of concrete tactile paving blocks made with recycled tire rubber. *Construction and Building Materials*, 91: 71-79.
- Daczko, J. A. (2012). *Self-consolidating concrete: applying what we know*: CRC Press.
- de Castro, S., & de Brito, J. (2013). Evaluation of the durability of concrete made with crushed glass aggregates. *Journal of Cleaner Production*, 41(0): 7-14.
- DECC, D. (2011). Guidelines to Defra/DECC's GHG Conversion Factors for Company Reporting *Department for Environment, Food and Rural Affairs and Department for Energy and Climate Change* (pp. 50). London, UK. .

- Delagrave, A., Bigas, J. P., Ollivier, J. P., Marchand, J., & Pigeon, M. (1997). Influence of the interfacial zone on the chloride diffusivity of mortars. *Advanced Cement Based Materials*, 5(3–4): 86-92.
- Dhir, R. K. (1999). *Exploiting wastes in concrete: proceedings of the international seminar held at the University of Dundee, Scotland, UK on 7 September 1999*: Thomas Telford.
- Dias, W., Khoury, G., & Sullivan, P. (1990). Mechanical properties of hardened cement paste exposed to temperatures up to 700 C (1292 F). *ACI Materials Journal*, 87(2).
- Dinakar, P., & Manu, S. N. (2014). Concrete mix design for high strength self-compacting concrete using metakaolin. *Materials & Design*, 60(0): 661-668.
- Dinakar, P., Sethy, K. P., & Sahoo, U. C. (2013). Design of self-compacting concrete with ground granulated blast furnace slag. *Materials & Design*, 43: 161-169.
- Dogan, U. A., & Ozkul, M. H. (2015). The effect of cement type on long-term transport properties of self-compacting concretes. *Construction and Building Materials*, 96: 641-647.
- Domone, P. (2006). Mortar tests for material selection and mix design of SCC. *Concrete International*, 28(4): 39-45.
- Domone, P. (2006). Self-compacting concrete: An analysis of 11 years of case studies. *Cement and Concrete Composites*, 28(2): 197-208.
- Domone, P., & Jin, J. (1999). *Properties of mortar for self-compacting concrete*. Paper presented at the Proceedings of the 1st international RILEM symposium on self-compacting concrete.
- Domone, P. L. (2006). Self-compacting concrete: An analysis of 11 years of case studies. *Cement and Concrete Composites*, 28(2): 197-208.
- EFNARC. (2005). *The European guidelines for self-compacting concrete, specification, production and use* (pp. 68). Surrey, UK.
- El-Sayed, K., Guinea, G., Rocco, C., Planas, J., & Elices, M. (1998). Influence of aggregate shape on the fracture behaviour of concrete. *AEDIFICATIO Publishers, Fracture Mechanics of Concrete Structures*, 1: 171-180.

- Elices, M., & Rocco, C. (2008). Effect of aggregate size on the fracture and mechanical properties of a simple concrete. *Engineering Fracture Mechanics*, 75(13): 3839-3851.
- Eliche-Quesada, D., Corpas-Iglesias, F. A., Pérez-Villarejo, L., & Iglesias-Godino, F. J. (2012). Recycling of sawdust, spent earth from oil filtration, compost and marble residues for brick manufacturing. *Construction and Building Materials*, 34: 275-284.
- Elinwa, A. U., Ejeh, S. P., & Mamuda, A. M. (2008). Assessing of the fresh concrete properties of self-compacting concrete containing sawdust ash. *Construction and Building Materials*, 22(6): 1178-1182.
- Erdoğdu, Ş. (2005). Effect of retempering with superplasticizer admixtures on slump loss and compressive strength of concrete subjected to prolonged mixing. *Cement and Concrete Research*, 35(5): 907-912.
- Fakhfakh, E., Hajjaji, W., Medhioub, M., Rocha, F., López-Galindo, A., Setti, M., . . . Jamoussi, F. (2007). Effects of sand addition on production of lightweight aggregates from Tunisian smectite-rich clayey rocks. *Applied Clay Science*, 35(3): 228-237.
- Fares, H., Noumowe, A., & Remond, S. (2009). Self-consolidating concrete subjected to high temperature: Mechanical and physicochemical properties. *Cement and Concrete Research*, 39(12): 1230-1238.
- Faust, T. (2000). *Herstellung, Tragverhalten und Bemessung von konstruktivem Leichtbeton*: na.
- Felekoğlu, B., Tosun, K., Baradan, B., Altun, A., & Uyulgan, B. (2006). The effect of fly ash and limestone fillers on the viscosity and compressive strength of self-compacting repair mortars. *Cement and Concrete Research*, 36(9): 1719-1726.
- Felekoğlu, B., Türkel, S., & Baradan, B. (2007). Effect of water/cement ratio on the fresh and hardened properties of self-compacting concrete. *Building and Environment*, 42(4): 1795-1802.
- Ferrara, L., Park, Y.-D., & Shah, S. P. (2007). A method for mix-design of fiber-reinforced self-compacting concrete. *Cement and Concrete Research*, 37(6): 957-971.
- Funk, J. E., & Dinger, D. (1994). *Predictive process control of crowded particulate suspensions: applied to ceramic manufacturing*: Springer Science & Business Media.

- Ganjian, E., Jalull, G., & Sadeghi-Pouya, H. (2015). Using waste materials and by-products to produce concrete paving blocks. *Construction and Building Materials*, 77: 270-275.
- Gao, X., Kawashima, S., Liu, X., & Shah, S. P. (2012). Influence of clays on the shrinkage and cracking tendency of SCC. *Cement and Concrete Composites*, 34(4): 478-485.
- Gastaldini, A. L. G., da Silva, M. P., Zamberlan, F. B., & Mostardeiro Neto, C. Z. (2014). Total shrinkage, chloride penetration, and compressive strength of concretes that contain clear-colored rice husk ash. *Construction and Building Materials*, 54(0): 369-377.
- Gencil, O., Ozel, C., Koksall, F., Erdogmus, E., Martínez-Barrera, G., & Brostow, W. (2012). Properties of concrete paving blocks made with waste marble. *Journal of Cleaner Production*, 21(1): 62-70.
- Gesoğlu, M., Güneyisi, E., Ali, B., & Mermerdaş, K. (2013). Strength and transport properties of steam cured and water cured lightweight aggregate concretes. *Construction and Building Materials*, 49: 417-424.
- Gesoglu, M., Güneyisi, E., Ozturan, T., Oz, H. O., & Asaad, D. S. (2015). Shear thickening intensity of self-compacting concretes containing rounded lightweight aggregates. *Construction and Building Materials*, 79: 40-47.
- Gesoğlu, M., Güneyisi, E., Özturan, T., Öz, H. Ö., & Asaad, D. S. (2014a). Permeation characteristics of self compacting concrete made with partially substitution of natural aggregates with rounded lightweight aggregates. *Construction and Building Materials*, 59: 1-9.
- Gesoğlu, M., Güneyisi, E., Özturan, T., Öz, H. Ö., & Asaad, D. S. (2014b). Self-consolidating characteristics of concrete composites including rounded fine and coarse fly ash lightweight aggregates. *Composites Part B: Engineering*, 60: 757-763.
- Ghazi, F. K., & Al Jadiri, R. S. (2010). New method for proportioning self-consolidating concrete based on compressive strength requirements. *ACI Materials Journal*, 107(5).
- Ghernouti, Y., Rabehi, B., Bouziani, T., Ghezraoui, H., & Makhloufi, A. (2015). Fresh and hardened properties of self-compacting concrete containing plastic bag waste fibers (WFSCC). *Construction and Building Materials*, 82(0): 89-100.

- Girish, S., Ranganath, R. V., & Vengala, J. (2010). Influence of powder and paste on flow properties of SCC. *Construction and Building Materials*, 24(12): 2481-2488.
- Gobi, K., Mashitah, M. D., & Vadivelu, V. M. (2011). Adsorptive removal of Methylene Blue using novel adsorbent from palm oil mill effluent waste activated sludge: Equilibrium, thermodynamics and kinetic studies. *Chemical Engineering Journal*, 171(3): 1246-1252.
- Gołaszewski, J., & Szwabowski, J. (2004). Influence of superplasticizers on rheological behaviour of fresh cement mortars. *Cement and Concrete Research*, 34(2): 235-248.
- González-Corrochano, B., Alonso-Azcárate, J., & Rodas, M. (2009). Production of lightweight aggregates from mining and industrial wastes. *Journal of Environmental Management*, 90(8): 2801-2812.
- Grinys, A., Sivilevičius, H., Pupeikis, D., & Ivanauskas, E. (2013). Fracture of Concrete Containing Crumb Rubber. *Journal of Civil Engineering and Management*, 19(3): 447-455.
- Guney, Y., Sari, Y. D., Yalcin, M., Tuncan, A., & Donmez, S. (2010). Re-usage of waste foundry sand in high-strength concrete. [Research Support, Non-U.S. Gov't]. *Waste Manag*, 30(8-9): 1705-1713.
- Güneyisi, E., Gesoğlu, M., & Özbay, E. (2009). Effects of marble powder and slag on the properties of self compacting mortars. *Materials and Structures*, 42(6): 813-826.
- Guo, J., & Lua, A. C. (2001). Kinetic study on pyrolytic process of oil-palm solid waste using two-step consecutive reaction model. *Biomass and Bioenergy*, 20(3): 223-233.
- Hager, I. (2013). Behaviour of cement concrete at high temperature. *Bulletin of the Polish Academy of Sciences: Technical Sciences*, 61(1): 145-154.
- Hager, I. (2014). Colour change in heated concrete. *Fire Technology*, 50(4): 945-958.
- Halimah, M., Tan, Y. A., Nik Sasha, K. K., Zuriati, Z., Rawaida, A., & Choo, Y. M. (2013). Determination of life cycle inventory and greenhouse gas emissions for a selected oil palm nursery in Malaysia: A Case Study. *Journal of Oil Palm Research*, 25(December): 343-347.

- Hallal, A., Kadri, E. H., Ezziane, K., Kadri, A., & Khelafi, H. (2010). Combined effect of mineral admixtures with superplasticizers on the fluidity of the blended cement paste. *Construction and Building Materials*, 24(8): 1418-1423.
- Hamad, B. S., Rteil, A. A., & El-Fadel, M. (2003). Effect of used engine oil on properties of fresh and hardened concrete. *Construction and Building Materials*, 17(5): 311-318.
- Hambali, E., Thahar, A., & Komarudin, A. (2010). *The potential of oil palm and rice biomass as bioenergy feedstock*. Paper presented at the Proceeding of 7th Biomass Asia Workshop. Jakarta, Indonesia.
- Hamid, R., Yusof, K. M., & Zain, M. F. M. (2010). A combined ultrasound method applied to high performance concrete with silica fume. *Construction and Building Materials*, 24(1): 94-98.
- Hansen, U. E., & Nygaard, I. (2014). Sustainable energy transitions in emerging economies: The formation of a palm oil biomass waste-to-energy niche in Malaysia 1990–2011. *Energy Policy*, 66(0): 666-676.
- Haque, M., Al-Khaiat, H., & Kayali, O. (2004). Strength and durability of lightweight concrete. *Cement and Concrete Composites*, 26(4): 307-314.
- Harimi, M., Megat Ahmad, M. M. H., Sapuan, S. M., & Idris, A. (2005). Numerical analysis of emission component from incineration of palm oil wastes. *Biomass and Bioenergy*, 28(3): 339-345.
- Harimi, M., Sapuan, S. M., Ahmad, M., & Abas, F. (2008). Numerical study of heat loss from boiler using different ratios of fibre-to-shell from palm oil wastes. *Journal of Scientific and Industrial Research*, 67(6): 440-444.
- Hasanbeigi, A., Menke, C., & Price, L. (2010). The CO₂ abatement cost curve for the Thailand cement industry. *Journal of Cleaner Production*, 18(15): 1509-1518.
- Hassan, A., Mahmud, H. B., Jumaat, M. Z., ALsubari, B., & Abdulla, A. (2013). Effect of Magnesium Sulphate on Self-Compacting Concrete Containing Supplementary Cementitious Materials. *Advances in Materials Science and Engineering*, 2013.
- Hassan, I., Ismail, M., Noruzman, A. H., Yusuf, T. O., Mehmannaavaz, T., & Usman, J. (2013). *Characterization of some key Industrial Waste products for sustainable Concrete production*. Paper presented at the Advanced Materials Research.

- Hassan, I. O., Ismail, M., Forouzani, P., Majid, Z. A., & Mirza, J. (2014). Flow characteristics of ternary blended self-consolidating cement mortars incorporating palm oil fuel ash and pulverised burnt clay. *Construction and Building Materials*, 64(0): 253-260.
- Hauke, B. (2001). *Self-compacting concrete for precast concrete products in Germany*. Paper presented at the Proceedings of the 2nd international RILEM symposium on self-compacting concrete. Tokyo: COMS Engineering Corporation.
- Heikal, M., Morsy, M., & Aiad, I. (2004). Effect of curing temperature on the electrical resistivity and rheological properties of superplasticized blended cement pastes. *Industria Italiana Del Cemento*: 772-785.
- Heikal, M., Zohdy, K. M., & Abdelkreem, M. (2013). Mechanical, microstructure and rheological characteristics of high performance self-compacting cement pastes and concrete containing ground clay bricks. *Construction and Building Materials*, 38: 101-109.
- Hewlett, P. (2003). *Lea's chemistry of cement and concrete*: Butterworth-Heinemann.
- Hong, L., Gu, X., & Lin, F. (2014). Influence of aggregate surface roughness on mechanical properties of interface and concrete. *Construction and Building Materials*, 65: 338-349.
- Hwang, C.-L., Bui, L. A.-T., Lin, K.-L., & Lo, C.-T. (2012). Manufacture and performance of lightweight aggregate from municipal solid waste incinerator fly ash and reservoir sediment for self-consolidating lightweight concrete. *Cement and Concrete Composites*, 34(10): 1159-1166.
- Hwang, C.-L., & Hung, M.-F. (2005). Durability design and performance of self-consolidating lightweight concrete. *Construction and Building Materials*, 19(8): 619-626.
- Hwang, C.-L., & Tran, V.-A. (2015). A study of the properties of foamed lightweight aggregate for self-consolidating concrete. *Construction and Building Materials*, 87: 78-85.
- Igwe, J., & Onyegbado, C. (2007). A review of palm oil mill effluent (POME) water treatment. *Global Journal of Environmental Research*, 1(2): 54-62.
- Ismail, Z. Z., & Al-Hashmi, E. A. (2008). Use of waste plastic in concrete mixture as aggregate replacement. [Research Support, Non-U.S. Gov't]. *Waste Manag*, 28(11): 2041-2047.

- Jaturapitakkul, C., Kiattikomol, K., Tangchirapat, W., & Saeting, T. (2007). Evaluation of the sulfate resistance of concrete containing palm oil fuel ash. *Construction and Building Materials*, 21(7): 1399-1405.
- Jiménez-Quero, V. G., León-Martínez, F. M., Montes-García, P., Gaona-Tiburcio, C., & Chacón-Nava, J. G. (2013). Influence of sugar-cane bagasse ash and fly ash on the rheological behavior of cement pastes and mortars. *Construction and Building Materials*, 40: 691-701.
- Johari, A., Nyakuma, B. B., Mohd Nor, S. H., Mat, R., Hashim, H., Ahmad, A., . . . Tuan Abdullah, T. A. (2015). The challenges and prospects of palm oil based biodiesel in Malaysia. *Energy*, 81(0): 255-261.
- Jones, L. (1990). Interference mechanisms in waste stabilization/solidification processes. *Journal of Hazardous materials*, 24(1): 83-88.
- Jumaat, M. Z., Alengaram, U. J., Ahmmad, R., Bahri, S., & Islam, A. B. M. S. (2015). Characteristics of palm oil clinker as replacement for oil palm shell in lightweight concrete subjected to elevated temperature. *Construction and Building Materials*, 101, Part 1: 942-951.
- Kajaste, R., & Hurme, M. (2016). Cement industry greenhouse gas emissions – management options and abatement cost. *Journal of Cleaner Production*, 112, Part 5: 4041-4052.
- Kannan, V., & Ganesan, K. (2014). Chloride and chemical resistance of self compacting concrete containing rice husk ash and metakaolin. *Construction and Building Materials*, 51(0): 225-234.
- Karahan, O., Hossain, K. M. A., Ozbay, E., Lachemi, M., & Sancak, E. (2012). Effect of metakaolin content on the properties self-consolidating lightweight concrete. *Construction and Building Materials*, 31: 320-325.
- Karim, M. R., Hashim, H., & Abdul Razak, H. (2016). Thermal activation effect on palm oil clinker properties and their influence on strength development in cement mortar. *Construction and Building Materials*, 125: 670-678.
- Karjinni, V. V., & Anadinni, S. B. (2009). Mixture proportion procedure for SCC. *Indian concrete journal*, 83(6): 35-41.
- Kayali, O. (2008). Fly ash lightweight aggregates in high performance concrete. *Construction and Building Materials*, 22(12): 2393-2399.

- Kewalramani, M. A., & Gupta, R. (2006). Concrete compressive strength prediction using ultrasonic pulse velocity through artificial neural networks. *Automation in Construction*, 15(3): 374-379.
- Khairul Anuar, S., Maszura, S., Mohsin, S., & Norhaiza, G. (2015). The Potential of Cooling Effect Using Palm Oil Clinker as Drainage Layer in Green Roof System.
- Khaleel, O. R., & Abdul Razak, H. (2014). Mix design method for self compacting metakaolin concrete with different properties of coarse aggregate. *Materials & Design*, 53(0): 691-700.
- Khan, R., Jabbar, A., Ahmad, I., Khan, W., Khan, A. N., & Mirza, J. (2012). Reduction in environmental problems using rice-husk ash in concrete. *Construction and Building Materials*, 30(0): 360-365.
- Khayat, K. (1999). Workability, testing, and performance of self-consolidating concrete. *ACI Materials Journal*, 96(3).
- Khayat, K., & Mitchell, D. (2009). *Self-consolidating concrete for precast, prestressed concrete bridge elements* (Vol. 628): Transportation Research Board.
- Khelifa, R., Brunetaud, X., Chabil, H., & Al-Mukhtar, M. (2007). Consequences mecaniques de l'attaque sulfatique externe sur les betons autoplaçants. *Sciences & Technologie B*(28): 23-28.
- Khoury, G. (1992). Compressive strength of concrete at high temperatures: a reassessment. *Magazine of concrete Research*, 44(161): 291-309.
- Kim, Y. J., Choi, Y. W., & Lachemi, M. (2010). Characteristics of self-consolidating concrete using two types of lightweight coarse aggregates. *Construction and Building Materials*, 24(1): 11-16.
- Kinuthia, J., Snelson, D., & Gailius, A. (2009). Sustainable medium-strength concrete (CS-concrete) from colliery spoil in South Wales UK. *Journal of Civil Engineering and Management*, 15(2): 149-157.
- Kleinschrodt, H., & Winkler, H. (1986). The influence of the maximum aggregate size and the size of specimen on fracture mechanics parameters. *Fracture toughness and fracture energy of concrete*: 391-402.
- Klemm, W. A. (2005). Cement Soundness and the Autoclave Expansion Test-An Update of the Literature.

- Koksal, F., Gencil, O., & Kaya, M. (2015). Combined effect of silica fume and expanded vermiculite on properties of lightweight mortars at ambient and elevated temperatures. *Construction and Building Materials*, 88: 175-187.
- Kou, S.-c., Zhan, B.-j., & Poon, C.-s. (2012). Feasibility study of using recycled fresh concrete waste as coarse aggregates in concrete. *Construction and Building Materials*, 28(1): 549-556.
- Kou, S., & Poon, C. (2009). Properties of self-compacting concrete prepared with coarse and fine recycled concrete aggregates. *Cement and Concrete Composites*, 31(9): 622-627.
- Kou, S. C., & Poon, C. S. (2009). Properties of self-compacting concrete prepared with coarse and fine recycled concrete aggregates. *Cement and Concrete Composites*, 31(9): 622-627.
- Kraus, R. N., Naik, T. R., Ramme, B. W., & Kumar, R. (2009). Use of foundry silica-dust in manufacturing economical self-consolidating concrete. *Construction and Building Materials*, 23(11): 3439-3442.
- Lam, C. S., Poon, C. S., & Chan, D. (2007). Enhancing the performance of pre-cast concrete blocks by incorporating waste glass – ASR consideration. *Cement and Concrete Composites*, 29(8): 616-625.
- Latif Ahmad, A., Ismail, S., & Bhatia, S. (2003). Water recycling from palm oil mill effluent (POME) using membrane technology. *Desalination*, 157(1–3): 87-95.
- Le, H. T., Kraus, M., Siewert, K., & Ludwig, H.-M. (2015a). Effect of macro-mesoporous rice husk ash on rheological properties of mortar formulated from self-compacting high performance concrete. *Construction and Building Materials*, 80: 225-235.
- Le, H. T., Müller, M., Siewert, K., & Ludwig, H.-M. (2015b). The mix design for self-compacting high performance concrete containing various mineral admixtures. *Materials & Design*, 72(0): 51-62.
- Ledesma, E. F., Jiménez, J. R., Ayuso, J., Fernández, J. M., & de Brito, J. (2015). Maximum feasible use of recycled sand from construction and demolition waste for eco-mortar production – Part-I: ceramic masonry waste. *Journal of Cleaner Production*, 87: 692-706.
- Lim, N. H. A. S., Ismail, M. A., Lee, H. S., Hussin, M. W., Sam, A. R. M., & Samadi, M. (2015). The effects of high volume nano palm oil fuel ash on microstructure properties and hydration temperature of mortar. *Construction and Building Materials*, 93(0): 29-34.

- Lima, P. R., Leite, M. B., & Santiago, E. Q. (2010). Recycled lightweight concrete made from footwear industry waste and CDW. [Research Support, Non-U.S. Gov't]. *Waste Manag*, 30(6): 1107-1113.
- Ling, T.-C., & Poon, C.-S. (2012). Feasible use of recycled CRT funnel glass as heavyweight fine aggregate in barite concrete. *Journal of Cleaner Production*, 33(0): 42-49.
- Ling, T.-C., & Poon, C.-S. (2014). Use of recycled CRT funnel glass as fine aggregate in dry-mixed concrete paving blocks. *Journal of Cleaner Production*.
- Ling, T.-C., Poon, C.-S., & Kou, S.-C. (2012). Influence of recycled glass content and curing conditions on the properties of self-compacting concrete after exposure to elevated temperatures. *Cement and Concrete Composites*, 34(2): 265-272.
- Liu, M. (2010). Self-compacting concrete with different levels of pulverized fuel ash. *Construction and Building Materials*, 24(7): 1245-1252.
- Liu, R.-X., & Poon, C.-S. Utilization of red mud derived from bauxite in self-compacting concrete. *Journal of Cleaner Production*.
- Liu, X., Chia, K. S., & Zhang, M.-H. (2011). Water absorption, permeability, and resistance to chloride-ion penetration of lightweight aggregate concrete. *Construction and Building Materials*, 25(1): 335-343.
- Liu, X., Du, H., & Zhang, M.-H. (2015). A model to estimate the durability performance of both normal and light-weight concrete. *Construction and Building Materials*, 80: 255-261.
- Lo, T., Cui, H., Memon, S. A., & Noguchi, T. (2016). Manufacturing of sintered lightweight aggregate using high-carbon fly ash and its effect on the mechanical properties and microstructure of concrete. *Journal of Cleaner Production*, 112, Part 1: 753-762.
- Lo, T. Y., Tang, W. C., & Cui, H. Z. (2007). The effects of aggregate properties on lightweight concrete. *Building and Environment*, 42(8): 3025-3029.
- Loh, S. K., Lai, M., Ngatiman, M., Lim, W. S., Choo, Y. M., Zhang, Z., & Salimon, J. (2013). Zero Discharge Treatment Technology of Palm Oil Mill Effluent. *Journal of Oil Palm Research*, 25(3): 273-281.
- Long, G., Gao, Y., & Xie, Y. (2015). Designing more sustainable and greener self-compacting concrete. *Construction and Building Materials*, 84: 301-306.

- López, A., Tobes, J. M., Giaccio, G., & Zerbino, R. (2009). Advantages of mortar-based design for coloured self-compacting concrete. *Cement and Concrete Composites*, 31(10): 754-761.
- Lorenzi, A., Tisbieriek, F. T., & Silva, L. (2007). *Ultrasonic pulse velocity analysis in concrete specimens*. Paper presented at the Proceedings of IV Pan American conference for non destructive testing. Buenos Aires.
- Lotfy, A., Karahan, O., Ozbay, E., Hossain, K. M. A., & Lachemi, M. (2015). Effect of kaolin waste content on the properties of normal-weight concretes. *Construction and Building Materials*, 83: 102-107.
- Ma, A. (1999). Renewable energy from oil palm industry, in palm oil and environment. *Kuala Lumpur: MPOA*.
- Mahlia, T. M. I., Abdulmuin, M. Z., Alamsyah, T. M. I., & Mukhlisien, D. (2001). An alternative energy source from palm wastes industry for Malaysia and Indonesia. *Energy Conversion and Management*, 42(18): 2109-2118.
- Maia, L., Figueiras, H., Nunes, S., Azenha, M., & Figueiras, J. (2012). Influence of shrinkage reducing admixtures on distinct SCC mix compositions. *Construction and Building Materials*, 35: 304-312.
- Malaysia, A. I. (2011). National Biomass Strategy 2020: New wealth creation for Malaysia's palm oil industry. *Agensi Inovasi, Malaysia, Kuala Lumpur*.
- Malaysia, G. B. I. (2011). Green Building Index Criteria.
- Malhotra, V. (1999). *Role of supplementary cementing materials in reducing greenhouse gas emissions*. Paper presented at the Infrastructure regeneration and rehabilitation improving the quality of life through better construction. International conference.
- Malhotra, V. M. (1976). *Testing hardened concrete: nondestructive methods*: Iowa State Press.
- Mannan, M. A., & Ganapathy, C. (2002). Engineering properties of concrete with oil palm shell as coarse aggregate. *Construction and Building Materials*, 16(1): 29-34.
- Martí-Vargas, J., Serna-Ros, P., Arbeláez, C., & Rigueira-Víctor, J. (2006). Comportamiento adherente del hormigón autocompactante en transmisión y anclaje. *Materiales de construcción*, 56(284): 27-42.

- Martín, J., Rodríguez Montero, J., Moreno, F., Piqueras Sala, J. L., & Rubio, M. C. (2013). Feasibility analysis of the reuse of waste filler of bituminous mixtures for the production of self-compacting concrete. *Materials & Design*, 46: 372-380.
- Mathew, G., & Paul, M. M. (2012). Mix design methodology for laterized self compacting concrete and its behaviour at elevated temperature. *Construction and Building Materials*, 36(0): 104-109.
- Matos, A. M., & Sousa-Coutinho, J. (2012). Durability of mortar using waste glass powder as cement replacement. *Construction and Building Materials*, 36: 205-215.
- Mazaheripour, H., Ghanbarpour, S., Mirmoradi, S. H., & Hosseinpour, I. (2011). The effect of polypropylene fibers on the properties of fresh and hardened lightweight self-compacting concrete. *Construction and Building Materials*, 25(1): 351-358.
- Medina, C., Sánchez de Rojas, M. I., & Frías, M. (2012). Reuse of sanitary ceramic wastes as coarse aggregate in eco-efficient concretes. *Cement and Concrete Composites*, 34(1): 48-54.
- Mehta, P. K. (1986). Concrete. Structure, properties and materials.
- Mehta, P. K. (1986). *Concrete: structure, properties, and materials*: Prentice-Hall.
- Mehta, P. K. (2002). Greening of the Concrete Industry for Sustainable Development. *Concrete International*, 23.
- Mehta, P. K. (2004). *High-performance, high-volume fly ash concrete for sustainable development*. Paper presented at the Proceedings of the international workshop on sustainable development and concrete technology.
- Mehta, P. K., & Monteiro, P. J. (2006). *Concrete: microstructure, properties, and materials* (Vol. 3): McGraw-Hill New York.
- Merlini, M., Artioli, G., Cerulli, T., Cella, F., & Bravo, A. (2008). Tricalcium aluminate hydration in additivated systems. A crystallographic study by SR-XRPD. *Cement and Concrete Research*, 38(4): 477-486.
- Meyer, C. (2009). The greening of the concrete industry. *Cement and Concrete Composites*, 31(8): 601-605.

- Miličević, I., Bjegović, D., & Siddique, R. (2015). Experimental research of concrete floor blocks with crushed bricks and tiles aggregate. *Construction and Building Materials*, 94: 775-783.
- Mineral Products Association. (2012). Fact Sheet 18 [Part 1] Embodied CO₂ of UK cement, additions and cementitious material (pp. 8). Gillingham, UK. .
- Mo, K. H., Alengaram, U. J., Visintin, P., Goh, S. H., & Jumaat, M. Z. (2015). Influence of lightweight aggregate on the bond properties of concrete with various strength grades. *Construction and Building Materials*, 84(0): 377-386.
- Mo, K. H., Yap, K. K. Q., Alengaram, U. J., & Jumaat, M. Z. (2014). The effect of steel fibres on the enhancement of flexural and compressive toughness and fracture characteristics of oil palm shell concrete. *Construction and Building Materials*, 55(0): 20-28.
- Mohamed, H. A. (2011). Effect of fly ash and silica fume on compressive strength of self-compacting concrete under different curing conditions. *Ain Shams Engineering Journal*, 2(2): 79-86.
- Mohammed, B. S., Foo, W. L., & Abdullahi, M. (2014). Flexural strength of palm oil clinker concrete beams. *Materials & Design*, 53(0): 325-331.
- Mohammed, B. S., Foo, W. L., Hossain, K. M. A., & Abdullahi, M. (2013). Shear strength of palm oil clinker concrete beams. *Materials & Design*, 46: 270-276.
- Mohammed, M. K., Dawson, A. R., & Thom, N. H. (2014). Macro/micro-pore structure characteristics and the chloride penetration of self-compacting concrete incorporating different types of filler and mineral admixture. *Construction and Building Materials*, 72: 83-93.
- Moretti, J. P., Sales, A., Almeida, F. C. R., Rezende, M. A. M., & Gromboni, P. P. (2016). Joint use of construction waste (CW) and sugarcane bagasse ash sand (SBAS) in concrete. *Construction and Building Materials*, 113: 317-323.
- Mostofinejad, D., & Reisi, M. (2012). A new DEM-based method to predict packing density of coarse aggregates considering their grading and shapes. *Construction and Building Materials*, 35: 414-420.
- MPOB. (2014). Economics & Industry Development Division. *Malaysian Palm Oil Board*.
- MPOB. (2015). Economics & Industry Development Division. *Malaysian Palm Oil Board*.

- Mumtaz, T., Yahaya, N. A., Abd-Aziz, S., Abdul Rahman, N. A., Yee, P. L., Shirai, Y., & Hassan, M. A. (2010). Turning waste to wealth-biodegradable plastics polyhydroxyalkanoates from palm oil mill effluent – a Malaysian perspective. *Journal of Cleaner Production*, 18(14): 1393-1402.
- Mun, K. J. (2007). Development and tests of lightweight aggregate using sewage sludge for nonstructural concrete. *Construction and Building Materials*, 21(7): 1583-1588.
- Mun, T. L. (2010). The Development of GBI Malaysia (GBI): vol.
- Naik, T. R., Kumar, R., Ramme, B. W., & Canpolat, F. (2012). Development of high-strength, economical self-consolidating concrete. *Construction and Building Materials*, 30: 463-469.
- Najim, K. B., & Hall, M. R. (2012). Mechanical and dynamic properties of self-compacting crumb rubber modified concrete. *Construction and Building Materials*, 27(1): 521-530.
- Nanthagopalan, P., Haist, M., Santhanam, M., & Müller, H. S. (2008). Investigation on the influence of granular packing on the flow properties of cementitious suspensions. *Cement and Concrete Composites*, 30(9): 763-768.
- Nassar, R.-U.-D., & Soroushian, P. (2012). Strength and durability of recycled aggregate concrete containing milled glass as partial replacement for cement. *Construction and Building Materials*, 29: 368-377.
- Nehdi, M., Pardhan, M., & Koshowski, S. (2004). Durability of self-consolidating concrete incorporating high-volume replacement composite cements. *Cement and Concrete Research*, 34(11): 2103-2112.
- Nepomuceno, M. C. S., Pereira-de-Oliveira, L. A., & Lopes, S. M. R. (2014). Methodology for the mix design of self-compacting concrete using different mineral additions in binary blends of powders. *Construction and Building Materials*, 64(0): 82-94.
- Neville, A. M. (1973). *Properties of concrete*: Pitman.
- Ng, F. Y., Yew, F. K., Basiron, Y., & Sundram, K. (2012). A renewable future driven with Malaysian palm oil-based green technology. *Journal of Oil Palm, Environment and Health (JOPEH)*, 2.
- Ngan, M., & Ong, A. (1987). Potential biomass energy from palm oil industry. *PORIM Bulletin, Palm Oil Research Institute, Malaysia*(14): 10-15.

- Noruzman, A. H., Muhammad, B., Ismail, M., & Abdul-Majid, Z. (2012). Characteristics of treated effluents and their potential applications for producing concrete. *Journal of Environmental Management*, 110(0): 27-32.
- Okamura, H., & Ouchi, M. (2003). Self-compacting concrete. *Journal of Advanced Concrete Technology*, 1(1): 5-15.
- Okamura, H., & Ozawa, K. (1995). Mix design for self-compacting concrete. *Concrete Library Japan Society Civil Engineer*, 25(6): 107-120.
- Onoue, K., Tamai, H., & Suseno, H. (2015). Shock-absorbing capability of lightweight concrete utilizing volcanic pumice aggregate. *Construction and Building Materials*, 83(0): 261-274.
- Paiva, H., Silva, L. M., Labrincha, J. A., & Ferreira, V. M. (2006). Effects of a water-retaining agent on the rheological behaviour of a single-coat render mortar. *Cement and Concrete Research*, 36(7): 1257-1262.
- Paramanathan, S. (2000). *Soils of Malaysia: their characteristics and identification, Volume 1*: Academy of Sciences Malaysia.
- Park, C. K., Noh, M. H., & Park, T. H. (2005). Rheological properties of cementitious materials containing mineral admixtures. *Cement and Concrete Research*, 35(5): 842-849.
- Pathak, N., & Siddique, R. (2012). Effects of elevated temperatures on properties of self-compacting-concrete containing fly ash and spent foundry sand. *Construction and Building Materials*, 34: 512-521.
- Penteado, C. S. G., Viviani de Carvalho, E., & Lintz, R. C. C. (2016). Reusing ceramic tile polishing waste in paving block manufacturing. *Journal of Cleaner Production*, 112, Part 1: 514-520.
- Petersson, O., & Billberg, P. (1999). *Investigation on blocking of self-compacting concrete with different maximum aggregate size and use of viscosity agent instead of filler*. Paper presented at the 1st International RILEM Symposium on Self Compacting Concrete. Cachan: Reunion Internationale des Laboratoires d'Essais et de Recherches sur les Materiaux et les Constructions, RILEM.
- Phan, L. T., & Carino, N. J. (2000). *Fire performance of high strength concrete: research needs*. Paper presented at the Advanced technology in structural engineering, ASCE/SEI structures congress.

- Pliya, P., & Cree, D. (2015). Limestone derived eggshell powder as a replacement in Portland cement mortar. *Construction and Building Materials*, 95: 1-9.
- Prassianakis, I., & Prassianakis, N. (2004). Ultrasonic testing of non-metallic materials: concrete and marble. *Theoretical and applied fracture mechanics*, 42(2): 191-198.
- Prusinski, J. R., Marceau, M. L., & VanGeem, M. G. (2004). *Life cycle inventory of slag cement concrete*. Paper presented at the Eighth CANMET/ACI International Conference on Fly Ash, Silica Fume, Slag and Natural Pozzolans in Concrete.
- Quiroga, P. N., & Fowler, D. W. (2004). The effects of aggregates characteristics on the performance of Portland cement concrete: International Center for Aggregates Research, University of Texas at Austin.
- Rahman, M. M., Usman, M., & Al-Ghalib, A. A. (2012). Fundamental properties of rubber modified self-compacting concrete (RMSCC). *Construction and Building Materials*, 36: 630-637.
- Ramezaniapour, A. A. (2014). *Cement replacement materials*: Springer.
- Ramezaniapour, A. M., Esmaili, K., Ghahari, S. A., & Ramezaniapour, A. A. (2014). Influence of initial steam curing and different types of mineral additives on mechanical and durability properties of self-compacting concrete. *Construction and Building Materials*, 73: 187-194.
- Ranjbar, N., Behnia, A., Alsubari, B., Birgani, P. M., & Jumaat, M. Z. (2015). Durability and mechanical properties of self-compacting concrete incorporating palm oil fuel ash. *Journal of Cleaner Production*.
- Rashid, M., Chong, W., Ramli, M., Zainura, Z., & NorRuwaida, J. (2013). Evaluation of particulate emission from a palm oil mill boiler. *Sains Malaysiana*, 42(9): 1289-1292.
- Rawal, P. (2003). *Development of durable concrete from pulverized fly ash and pozzolan derived from agricultural wastes*. Master of Engineering. Thesis Number ST-82-1. Asian Institute Technology.
- Razi, P. Z., & Abdul Razak, H. (2012). Environmental Sustainability and Engineering Performance of Self-Compacting Mortar Incorporating Fly Ashes. *Applied Mechanics and Materials*, 253-255: 559-563.
- Reis, S. (2005). *Costs of air pollution control*: Springer.

- Rerkpiboon, A., Tangchirapat, W., & Jaturapitakkul, C. (2015). Strength, chloride resistance, and expansion of concretes containing ground bagasse ash. *Construction and Building Materials*, 101, Part 1: 983-989.
- Rizwan, S. A., & Bier, T. A. (2012). Blends of limestone powder and fly-ash enhance the response of self-compacting mortars. *Construction and Building Materials*, 27(1): 398-403.
- Roussel, N. (2006). Correlation between yield stress and slump: comparison between numerical simulations and concrete rheometers results. *Materials and Structures*, 39(4): 501-509.
- Rozière, E., Granger, S., Turcry, P., & Loukili, A. (2007). Influence of paste volume on shrinkage cracking and fracture properties of self-compacting concrete. *Cement and Concrete Composites*, 29(8): 626-636.
- Rukzon, S., & Chindapasirt, P. (2012). Utilization of bagasse ash in high-strength concrete. *Materials & Design*, 34: 45-50.
- Rwamamara, R., & Simonsson, P. (2012). Self-compacting concrete use for construction work environment sustainability. *Journal of Civil Engineering and Management*, 18(5): 724-734.
- Saak, A. W., Jennings, H. M., & Shah, S. P. (2001). New methodology for designing self-compacting concrete. *ACI Materials Journal*, 98(6).
- Safi, B., Saidi, M., Daoui, A., Bellal, A., Mechekak, A., & Toumi, K. (2015). The use of seashells as a fine aggregate (by sand substitution) in self-compacting mortar (SCM). *Construction and Building Materials*, 78: 430-438.
- Safiuddin, M., West, J. S., & Soudki, K. A. (2012). Properties of freshly mixed self-consolidating concretes incorporating rice husk ash as a supplementary cementing material. *Construction and Building Materials*, 30: 833-842.
- Şahmaran, M., Christianto, H. A., & Yaman, İ. Ö. (2006). The effect of chemical admixtures and mineral additives on the properties of self-compacting mortars. *Cement and Concrete Composites*, 28(5): 432-440.
- Şahmaran, M., Özkan, N., Keskin, S. B., Uzal, B., Yaman, İ. Ö., & Erdem, T. K. (2008). Evaluation of natural zeolite as a viscosity-modifying agent for cement-based grouts. *Cement and Concrete Research*, 38(7): 930-937.

- Saleh Ahari, R., Erdem, T. K., & Ramyar, K. (2015). Permeability properties of self-consolidating concrete containing various supplementary cementitious materials. *Construction and Building Materials*, 79: 326-336.
- Saleh, R., Kemal, T., & Ramyar, K. (2015). Effect of various supplementary cementitious materials on rheological properties of self-consolidating concrete. *Construction and Building Materials*, 75: 89-98.
- Saouma, V. E., Broz, J. J., Brühwiler, E., & Boggs, H. L. (1991). Effect of aggregate and specimen size on fracture properties of dam concrete. *Journal of Materials in Civil Engineering*, 3(3): 204-218.
- Sebaibi, N., Benzerzour, M., Sebaibi, Y., & Abriak, N.-E. (2013). Composition of self compacting concrete (SCC) using the compressible packing model, the Chinese method and the European standard. *Construction and Building Materials*, 43(0): 382-388.
- Senthamarai, R. M., Manoharan, P. D., & Gobinath, D. (2011). Concrete made from ceramic industry waste: Durability properties. *Construction and Building Materials*, 25(5): 2413-2419.
- Sethy, K. P., Pasla, D., & Chandra Sahoo, U. (2016). Utilization of high volume of industrial slag in self compacting concrete. *Journal of Cleaner Production*, 112, Part 1: 581-587.
- Sfikas, I. P., & Trezos, K. G. (2013). Effect of composition variations on bond properties of Self-Compacting Concrete specimens. *Construction and Building Materials*, 41(0): 252-262.
- Shafigh, P., Jumaat, M. Z., & Mahmud, H. (2011). Oil palm shell as a lightweight aggregate for production high strength lightweight concrete. *Construction and Building Materials*, 25(4): 1848-1853.
- Shafigh, P., Mahmud, H. B., Jumaat, M. Z. B., Ahmmad, R., & Bahri, S. (2014). Structural lightweight aggregate concrete using two types of waste from the palm oil industry as aggregate. *Journal of Cleaner Production*, 80: 187-196.
- Shi, C., Wu, Z., Lv, K., & Wu, L. (2015). A review on mixture design methods for self-compacting concrete. *Construction and Building Materials*, 84(0): 387-398.
- Short, N., Purkiss, J., & Guise, S. (2001). Assessment of fire damaged concrete using colour image analysis. *Construction and Building Materials*, 15(1): 9-15.

- Shuit, S. H., Tan, K. T., Lee, K. T., & Kamaruddin, A. H. (2009). Oil palm biomass as a sustainable energy source: A Malaysian case study. *Energy*, 34(9): 1225-1235.
- Siad, H., Kamali-Bernard, S., Mesbah, H. A., Escadeillas, G., Mouli, M., & Khelafi, H. (2013). Characterization of the degradation of self-compacting concretes in sodium sulfate environment: Influence of different mineral admixtures. *Construction and Building Materials*, 47: 1188-1200.
- Siddique, R. (2013). Compressive strength, water absorption, sorptivity, abrasion resistance and permeability of self-compacting concrete containing coal bottom ash. *Construction and Building Materials*, 47: 1444-1450.
- Siddique, R., Khatib, J., & Kaur, I. (2008). Use of recycled plastic in concrete: a review. *Waste Management*, 28(10): 1835-1852.
- Siddique, R., Singh, G., Belarbi, R., Ait-Mokhtar, K., & Kunal. (2015). Comparative investigation on the influence of spent foundry sand as partial replacement of fine aggregates on the properties of two grades of concrete. *Construction and Building Materials*, 83: 216-222.
- Soroka, I., & Ravina, D. (1998). Hot weather concreting with admixtures. *Cement and Concrete Composites*, 20(2-3): 129-136.
- Su, N., Hsu, K.-C., & Chai, H.-W. (2001). A simple mix design method for self-compacting concrete. *Cement and Concrete Research*, 31(12): 1799-1807.
- Sua-iam, G., & Makul, N. (2014). Utilization of high volumes of unprocessed lignite-coal fly ash and rice husk ash in self-consolidating concrete. *Journal of Cleaner Production*, 78(0): 184-194.
- Sua-iam, G., & Makul, N. (2015). Rheological and mechanical properties of cement-fly ash self-consolidating concrete incorporating high volumes of alumina-based material as fine aggregate. *Construction and Building Materials*, 95: 736-747.
- Sulaiman, F., Abdullah, N., Gerhauser, H., & Shariff, A. (2011). An outlook of Malaysian energy, oil palm industry and its utilization of wastes as useful resources. *Biomass and Bioenergy*, 35(9): 3775-3786.
- Sundram, K., Chenayah, S., Sasekumar, A., Aikanathan, S., & Basiron, Y. (2015). Sustainable Management of Oil Palm Plantation Industry and the Perception Implications. *Journal of Oil Palm, Environment and Health (JOPEH)*, 6.

- Sutcu, M., Alptekin, H., Erdogmus, E., Er, Y., & Gencel, O. (2015). Characteristics of fired clay bricks with waste marble powder addition as building materials. *Construction and Building Materials*, 82: 1-8.
- Tangchirapat, W., & Jaturapitakkul, C. (2010). Strength, drying shrinkage, and water permeability of concrete incorporating ground palm oil fuel ash. *Cement and Concrete Composites*, 32(10): 767-774.
- Tangchirapat, W., Jaturapitakkul, C., & Chindapasirt, P. (2009). Use of palm oil fuel ash as a supplementary cementitious material for producing high-strength concrete. *Construction and Building Materials*, 23(7): 2641-2646.
- Tasdemir, C. (2003). Combined effects of mineral admixtures and curing conditions on the sorptivity coefficient of concrete. *Cement and Concrete Research*, 33(10): 1637-1642.
- Tasdemir, C., Tasdemir, M. A., Mills, N., Barr, B. I., & Lydon, F. D. (1999). Combined Effects of Silica Fume, Aggregate Type, and Size on Post-Peak Response of Concrete in Bending. *ACI Materials Journal*, 96(1).
- Tasdemir, M., Tasdemir, C., Akyüz, S., Jefferson, A., Lydon, F., & Barr, B. (1998). Evaluation of strains at peak stresses in concrete: a three-phase composite model approach. *Cement and Concrete Composites*, 20(4): 301-318.
- Tattersall, G. H. (2003). *Workability and quality control of concrete*: CRC Press.
- Tennich, M., Kallel, A., & Ben Oueddou, M. (2015). Incorporation of fillers from marble and tile wastes in the composition of self-compacting concretes. *Construction and Building Materials*, 91: 65-70.
- Tian, Y., Shi, S., Jia, K., & Hu, S. (2015). Mechanical and dynamic properties of high strength concrete modified with lightweight aggregates presaturated polymer emulsion. *Construction and Building Materials*, 93: 1151-1156.
- Topçu, İ. B., Bilir, T., & Uygunoğlu, T. (2009). Effect of waste marble dust content as filler on properties of self-compacting concrete. *Construction and Building Materials*, 23(5): 1947-1953.
- Topçu, İ. B., & Uygunoğlu, T. (2010). Effect of aggregate type on properties of hardened self-consolidating lightweight concrete (SCLC). *Construction and Building Materials*, 24(7): 1286-1295.

- Tuan, B. L. A., Hwang, C.-L., Lin, K.-L., Chen, Y.-Y., & Young, M.-P. (2013). Development of lightweight aggregate from sewage sludge and waste glass powder for concrete. *Construction and Building Materials*, 47(0): 334-339.
- Turatsinze, A., & Garros, M. (2008). On the modulus of elasticity and strain capacity of Self-Compacting Concrete incorporating rubber aggregates. *Resources, Conservation and Recycling*, 52(10): 1209-1215.
- Umar, M. S., Jennings, P., & Urmee, T. (2014). Sustainable electricity generation from oil palm biomass wastes in Malaysia: An industry survey. *Energy*, 67(0): 496-505.
- Ünal, O., Uygunoğlu, T., & Yildiz, A. (2007). Investigation of properties of low-strength lightweight concrete for thermal insulation. *Building and Environment*, 42(2): 584-590.
- Uygunoğlu, T., Topcu, I. B., Gencil, O., & Brostow, W. (2012). The effect of fly ash content and types of aggregates on the properties of pre-fabricated concrete interlocking blocks (PCIBs). *Construction and Building Materials*, 30: 180-187.
- Uysal, M., & Yilmaz, K. (2011). Effect of mineral admixtures on properties of self-compacting concrete. *Cement and Concrete Composites*, 33(7): 771-776.
- Valcuende, M., Parra, C., Marco, E., Garrido, A., Martínez, E., & Cánoves, J. (2012). Influence of limestone filler and viscosity-modifying admixture on the porous structure of self-compacting concrete. *Construction and Building Materials*, 28(1): 122-128.
- Videla, C. (2000). Mixture proportioning methodology for structural sand-lightweight concrete. *ACI Materials Journal*, 97(3).
- Vijaya, S., Ma, A., Choo, Y., & Nik Meriam, N. (2008). Life cycle inventory of the production of crude palm oil—a gate to gate case study of 12 palm oil mills. *Journal of Oil Palm Research*, 20(June): 484-494.
- Vijayalakshmi, M., Sekar, A. S. S., & Ganesh prabhu, G. (2013). Strength and durability properties of concrete made with granite industry waste. *Construction and Building Materials*, 46: 1-7.
- Volland, S., & Brötz, J. (2015). Lightweight aggregates produced from sand sludge and zeolitic rocks. *Construction and Building Materials*, 85(0): 22-29.
- Wallevik, J. E. (2006). Relationship between the Bingham parameters and slump. *Cement and Concrete Research*, 36(7): 1214-1221.

- Walraven, J. (2003). *Structural applications of self compacting concrete*. Paper presented at the Proceedings of the 3 rd RILEM International Symposium on Self Compacting Concrete, Reykjavik, Iceland.
- Wang, H.-Y., & Huang, W.-L. (2010). Durability of self-consolidating concrete using waste LCD glass. *Construction and Building Materials*, 24(6): 1008-1013.
- Wang, H. Y., & Huang, W. L. (2010). A study on the properties of fresh self-consolidating glass concrete (SCGC). *Construction and Building Materials*, 24(4): 619-624.
- Wang, Y., Zhu, Q., & Geng, Y. (2013). Trajectory and driving factors for GHG emissions in the Chinese cement industry. *Journal of Cleaner Production*, 53(0): 252-260.
- Wasserman, R., & Bentur, A. (1997). Effect of lightweight fly ash aggregate microstructure on the strength of concretes. *Cement and Concrete Research*, 27(4): 525-537.
- Wu, Q., & An, X. (2014). Development of a mix design method for SCC based on the rheological characteristics of paste. *Construction and Building Materials*, 53: 642-651.
- Wu, Z., Zhang, Y., Zheng, J., & Ding, Y. (2009). An experimental study on the workability of self-compacting lightweight concrete. *Construction and Building Materials*, 23(5): 2087-2092.
- Xiao, Z., Ling, T. C., Kou, S. C., Wang, Q., & Poon, C. S. (2011). Use of wastes derived from earthquakes for the production of concrete masonry partition wall blocks. [Research Support, Non-U.S. Gov't]. *Waste Manag*, 31(8): 1859-1866.
- Yang, S., Yue, X., Liu, X., & Tong, Y. (2015). Properties of self-compacting lightweight concrete containing recycled plastic particles. *Construction and Building Materials*, 84(0): 444-453.
- Yaogang, T., Shugang, H., & Qingjun, D. (2009). Physical and mechanical properties of high strength semi-light weight concrete. *Indian concrete journal*, 83(7): 19-24.
- Yu, Q. L., Spiesz, P., & Brouwers, H. J. H. (2015). Ultra-lightweight concrete: Conceptual design and performance evaluation. *Cement and Concrete Composites*, 61(0): 18-28.

- Yung, W. H., Yung, L. C., & Hua, L. H. (2013a). A study of the durability properties of waste tire rubber applied to self-compacting concrete. *Construction and Building Materials*, 41: 665-672.
- Yung, W. H., Yung, L. C., & Hua, L. H. (2013b). A study of the durability properties of waste tire rubber applied to self-compacting concrete. *Construction and Building Materials*, 41(0): 665-672.
- Yusoff, S. (2006). Renewable energy from palm oil – innovation on effective utilization of waste. *Journal of Cleaner Production*, 14(1): 87-93.
- Zhang, B., & Poon, C. S. (2015). Use of Furnace Bottom Ash for producing lightweight aggregate concrete with thermal insulation properties. *Journal of Cleaner Production*, 99(0): 94-100.
- Zhang, M.-H., & Gjørsv, O. E. (1991). Permeability of high-strength lightweight concrete. *ACI Materials Journal*, 88(5).
- Zhang, X., & Han, J. (2000). The effect of ultra-fine admixture on the rheological property of cement paste. *Cement and Concrete Research*, 30(5): 827-830.
- Zubaidi, R. A., Barakat, S., & Altoubat, S. (2013). Effects of adding brass byproduct on the basic properties of concrete. *Construction and Building Materials*, 38(0): 236-241.

LIST OF PUBLICATIONS AND PAPERS PRESENTED

Published Paper (Journal)

1. Kanadasan, J., & Abdul Razak, H. (2015). Engineering and sustainability performance of self-compacting palm oil mill incinerated waste concrete. *Journal of Cleaner Production*, 89(0), 78-86.
2. Kanadasan, J., & Razak, H. A. (2014b). Mix design for self-compacting palm oil clinker concrete based on particle packing. *Materials & Design*, 56(0), 9-19.
3. Kanadasan, J., Fauzi, A., Razak, H., Selliah, P., Subramaniam, V., & Yusoff, S. (2015). Feasibility studies of palm oil mill waste aggregates for the construction industry. *Materials*, 8(9), 5319.
4. Kanadasan, J., & Abdul Razak, H. (2015). Utilization of palm oil clinker as cement replacement material. *Materials*, 8(12), 5494.

Submitted Paper (Journal)

1. Kanadasan, J., Fauzi, A., Razak, H., Subramaniam, V., (2016). A cleaner approach for production of self-compacting concrete using palm oil mill boiler waste: Mechanical, economic and life cycle assessment.
2. Kanadasan, J., Fauzi, A., Razak, H., (2016). Assessment of high volume eco-friendly palm oil clinker fine aggregates incorporation in the construction industry.

Presented and Published Papers (Conference)

1. Kanadasan, J., & Abdul Razak, H. (2013). Lightweight self-compacting concrete using waste material from the palm oil industry. Proceedings of SCC 2013 (Chicago, USA).
2. Kanadasan, J., & Razak, H. A. (2014a). Fresh Properties of Self-Compacting Concrete Incorporating Palm Oil Clinker InCIEC 2013 (Kuching, Sarawak, Malaysia) (pp. 249-259): Springer.
3. Kanadasan, J., & Abdul Razak, H. (2015). Sustainability and engineering performance of palm oil mill waste as a sand replacement material. Proceedings of 35th Cement & Concrete Science Conference 2015 (Aberdeen, Scotland).
4. Kanadasan, J., & Abdul Razak, H., Sreedharan, V.K. (2015). Techniques of preparing self-compacting mortar. Proceedings of SKETMA 2015.