

CHAPTER FOUR

ANALYSIS AND FINDINGS

4.1. Introduction

This chapter presents the analyses of the evaluation of digital libraries as a successful Information System based on the adaptation of IS Success model namely the IS-Impact model. The discussion begins with a presentation of the preliminary investigation of the pre-test and pilot study performed prior to the actual fieldwork. Definitions of dimensions and measures were further elaborated, which was followed by a discussion on the results of reliability analysis. Although in the formative measurement model, as proposed in this study, the internal consistency test is irrelevant (Henseler, Ringle and Sinkovics, 2009), the results are still included in this thesis for descriptive purposes.

This chapter is designed as follows. The first section focuses on describing the data used in the pre-test and pilot study, which comprises the validity of the analysis based on the pre-test, as well as the response rate and the reliability test of the pilot survey. It is then followed by sections presenting statistical techniques that measured the individual usage impact hypothesized from the Digital Libraries Usage for Information Provisioning (DLUIP) dimensions and measures (Ambrose, Rai and Ramaprasad., 2006). The subsequent discussions continue with an analysis of the dimensions and measures to evaluate the digital libraries' performance by adopting the IS-Impact model derived by Gable, Sedera and Chan (2008). There are four key dimensions discussed in this chapter; which are individual impact, institutional impact, information quality and system quality.

4.2. Descriptive Analysis of the Pre-test and Pilot Study

In the preliminary study, a pre-test was conducted with the aim of getting an insight from experts in the field of digital library and survey methods, with regards to the validity of the questions designed in the questionnaires. The initial sets of questions were given to a selection of experts for discussion and verification process. Soon after the experts' review and feedback on the questions were received, the questions were revised and finalised for the pilot study. A set of sixty questionnaires were eventually prepared (15 sets distributed to each of the four universities) and the pilot study was conducted on subjects selected at random. The final pilot study questionnaire was designed with 68 questions.

The rate of response to the pilot survey was 76.7% (46 out of 60), with 27% from University Malaya (UM), 25% from Universiti Kebangsaan Malaysia (UKM), 21% from Universiti Sains Malaysia (USM) and 27% from Universiti Putra Malaysia (UPM). The rate of response was quite high despite the distribution period of questionnaires took place during the semester break.

4.3. Preliminary Data Analysis

The rationale for the preliminary analysis for the study is to ensure the generalisability and to avoid bias in the parameter estimations. Four main basic analyses performed for these purposes were related to the contributing mechanisms that affect the issue of missing data, sample size, non-normality and non-response bias. Each issue was handled based on statistical measures and assumptions in order to preserve the generalisability of the findings. SPSS was used as the analysis tools in the preliminary data analysis. Other general issues relating to the data of the study are discussed later, but work prior to the tasks undertaken for the data management are explained first.

4.3.1. Data-type Conversion

All the keyed-in data in SPSS version 16.0 were meant for descriptive and preliminary data analyses. However, in estimating the proposed model, *smartPLS* was used instead. Since this analysis tool can only accept data in Comma Separated Values (CSV) format, all the data are saved in the SPSS data sheet had to be converted into CSV format in order to be successfully used in *smartPLS*.

4.3.2. Data Re-coding

SPSS is well accepted for non-responsive answers for any measurement items where they are treated as missing values (coded as *dot* in the data sheet). However, it is not the same with *smartPLS*, where all the missing data in SPSS data sheet were re-coded as “999” as suggested by *smartPLS*.

4.3.3. Missing Data

The pattern of no response given by respondents for particular measurement items shows it is not in a systematic fashion, indicating that data are Missing At Random (MAR). Since the number of missing data is small (for instance, no answer given for Question B12 is 15), the approach of mean replacement is selected. Furthermore, the mean substitution approach is selected on the basis that the other methods (such as casewise deletion, pairwise deletion and mean imputation) have weaknesses such as biased parameter estimates (see Allison, 2002; Haitovsky, 1968).

4.3.4. Sample Size

As suggested by Ringle (2004: 16), the sample size recommended for Partial Least Squares (PLS) method is the product of ten with the highest number of paths leading to

any latent variable. This study's sample size compares favourably with the recommendation made by Ringle (2004). Additionally, PLS is robust against a small sample size (Ringle et al., 2009). Due to this reason, the proposed number of sample size was 1020.

4.3.5. Non-normality

Violations of normality assumption for Likert-scale interval data happens commonly in survey data. In this study, each indicator was scrutinised by checking the skewness and kurtosis values. Results showed that the skewness of indicators were between -0.87 and -0.05, and kurtosis between -0.720 and +1.30. Based on these results, no major departures from normality were detected in the items measured. However, the PLS method is very robust against non-normal data.

4.3.6. Non-response Bias

In checking the issue of non-response bias, the mean values of the *early* and *late* respondents were compared. The justification of using such techniques is referred to Oppenheim (1996). *Early* and *late* respondents were responses received at the beginning and ending of a survey, respectively. The first batch of questionnaires received was 50 (40 students and 10 academicians/researchers) and the last batch was 39 (24 students and 15 academicians/researchers).

All key indicators used in the model were tested using the *t*-test resulting in all (except two measurement items) being non-significant at the 0.05% significance level. The other two were found to be insignificant at the 0.01% level. Thus based on this test, non-response bias was not detected in the study.

Prior to presenting the findings to answer the research questions, sections 4.4 and 4.5 present the findings of the descriptive analysis of the study data.

4.4. Descriptive Analysis and Results

This section presents the findings of the descriptive analysis of the actual research. All of the descriptive analysis results based on measurement items in the questionnaires are presented in tables and figures.

4.4.1. Instrumentation

The questionnaires comprising the measurement items were developed to comply with the design of the study based on indicators developed by Ambrose, Rai and Ramaprasad (2006) and Gable, Sedera and Chan (2008). The IUIP model developed by Ambrose, Rai and Ramaprasad (2006) contained three formative (usage) constructs (Content Breadth, Content Depth and Interaction Dynamism). The IS-Impact model (Gable, Sedera and Chan, 2008) contained four formative constructs of Individual Impact, Organizational Impact, Information Quality and System Quality. All of the three formative constructs of IUIP were maintained; however, this study proposed the reconciliation of these constructs with the Individual Impact construct (as in Gable, Sedera and Chan, 2008). The construct is called the Individual Usage Impact. It is an attempt to extend the IUIP construct as a usage metric in the context of academic digital library usage.

The questionnaire consists of 75 questions (see Appendix C) divided into five main sections: demographic (Section A), internet/digital library experience/usage (Section B), awareness of digital library (Section C), digital library usage for information success (Section D) and digital library usage for information provisioning (Section E). Each item in Section C until Section E was measured using a five-point scale items, ranging from “1=strongly disagree” to “5=strongly agree”. The awareness section was scaled with from “1=strongly unfamiliar” to “5=strongly familiar”.

However, the Institutional Impact measures were scaled with discrete-event of 0 (No or Disagree) and 1 (Yes or Agree) and prepared in a separate questionnaire (see Appendix E).

The questionnaires were self administered and distributed to 1000 respondents comprising students and lecturers/researchers at four universities (250 for each). To obtain the inputs for Institutional Impact measures, 20 library personnel were contacted but only 15 agreed to participate. As a whole, a total of 1020 questionnaires were distributed, with 959 responses, resulting in a response rate of 94%.

The following table shows the detailed breakdown of response rate by the four participating universities.

Table 4.1: Response Rate by University

University	Distributed	Received	Rate of return (%)
UM	255	248	97.3
UKM	255	226	88.6
UPM	255	246	96.5
USM	255	239	93.7
Total	1,020	959	94.0

Table 4.1 exhibits the response rate of the questionnaires distributed to the four participating universities. Overall, the respondents from the selected universities demonstrated high rates of return, and were highly cooperative in helping to accomplish the objectives of the survey.

4.4.2. Respondents' Demographics

In conducting a survey, it is important to investigate the background of the survey subjects. Furthermore, in order to identify the indicators to evaluate the success of digital libraries, it is crucial to gather users who already have experience in using digital libraries in their study or research activities. Thus, this analysis was performed to

understand the inclination of the subjects' demographic that has brought to such findings for the pilot study.

The study included 959 participants, as mentioned, from academic institutions where the demographic profiles of the study subjects are as follows. Of the 959 participants, about 78% of them were students (both undergraduates and postgraduates), and 22% were staff of the university (lecturers/researchers/librarians). 43.9% were male and 56.1% female. The highest portion of the study subjects were those below 25 years of age (60.8%), 25-29 years (13%) and 35-39 years (9%). The age of the university undergraduate is commonly between 19-23 years, and since the majority of respondents were undergraduates, this category of age was the most dominant in this study.

Table 4.2: Number of Respondents (N=959)

Respondents	Total
Undergraduates	519
Postgraduates	225
<i>Total Students</i>	<i>744</i>
Research Assistants	18
Tutors	10
Lecturers	91
Senior Lecturers	62
Associate Professors	15
Professors	4
Librarians & Library IT Officers	15
<i>Total Staff</i>	<i>215</i>
Grand Total	959

The distribution of students and staff according to the specified categories is displayed in Table 4.2. The dominant category is the student group. The students, as well as the academic staff, were from more than 20 faculties of the four participating universities. The highest portion of respondents were from the faculty of Social Science

and Humanities (16.7%), followed by Computer Science and IT (9.9%) and Business/Finance/Banking (9.7%), as shown in Table 4.3.

Table 4.3: Percentage of Respondents, by Faculty

	Disciplines of Education	Percent
1.	Architecture	2.0
2.	Agriculture	3.2
3.	Business/Finance/Banking	9.7
4.	Computer Science &IT	9.9
5.	Dentistry	0.9
6.	Education	8.5
7.	Economics	5.5
8.	Engineering	9.4
9.	Food Science	1.3
10.	Health Science	0.7
11.	Islamic studies	1.4
12.	Linguistics	3.7
13.	Law	1.3
14.	Library & Information Science	0.3
15.	Medicine/Pharmacy	2.3
16.	Science	12.8
17.	Science & Technology	9.5
18.	Social Science & Humanities	16.7
19.	Veterinary Science	0.4
20.	Others	0.4

In addition, Table 4.3 exhibits the *Others* option as being the discipline of Maritime Management. More summary statistics are discussed in sections 4.4.4 to 4.4.5. The following sections present the findings on the reliability and validity analysis of the study sample, followed by the descriptive statistics of the research variables.

4.4.3. Reliability and Validity

Validity refers to measuring the survey instrument that actually measures the property it is supposed to measure. Validity analysis is performed on the pre-test data via consulting six experts (two locals and four internationals) with a strong background in digital libraries and survey method knowledge, while reliability analysis is for ensuring the reliability of the measurements used in the completed survey via a reliability analysis. Reliability is the consistency of measurement used for a survey instrument (or item). In producing the reliability results, Cronbach alpha (α) method was used. It is not a statistical test but a coefficient of consistency. Thus Cronbach (α) is a measure of internal consistency that uses the correlation between groups of a set of items to measure the similarities in the dimension. The closer the coefficient value to 1.00 the greater the internal consistency of the measures in each dimension. Each dimension proposed in evaluating IS Success model for digital libraries is transformed in the measures defined and grouped in the questionnaires as for Individual Impact, Institutional Impact, System Quality and Information Quality.

The preliminary analysis investigated the reliability measure for the key dimensions of the study. The reliability dimensions of each of the measurements are presented in the following table.

Table 4.4: Reliability of Instrument Measures

Model	Dimension	Number of Items	Cronbach α
IS-Impact	Individual Usage Impact	4	0.815
	Institutional Impact	8	0.735
	System Quality	15	0.924
	Information Quality	10	0.912
DLUIP	Content Breadth	7	0.910
	Content Depth	5	0.903
	Interaction Dynamism	4	0.854

The α values for the System Quality and Information Quality dimensions (as shown in Table 4.4) are among the highest, 0.92 and 0.91, respectively, suggesting that the items have relatively high internal consistency. It is noted that the alpha coefficient for Institutional Quality dimension is quite low (0.74), however in social science research, this coefficient of consistency value is acceptable. Insofar there is no agreed cutoff value, however, Nunnally (1978) noted that usually the value of 0.70 and above was preferable. Based on this rule of thumb, the internal consistency reliability for all of the dimensions are adequate. However, the results displayed in Table 4.1 may not serve the essence of the internal consistency of the measurement in the items. This is mainly because the study applied the *formative measurement model* where the model assessment is not as employed in the reflective mode. Previous studies (Edwards and Bagozzi, 2000; Bollen and Lennox, 1991; Fornell, 1982) demonstrated that *reflective indicators* were used in measuring latent constructs by positively correlated items. However, for formative indicators there is **no** pattern of inter-correlation expected or required. Thus this section serves as part of the descriptive analysis of constructs which are measured by questionnaire measurement items administered to the sample of the study.

4.4.4. Descriptive Analysis on Internet Knowledge, Experience and Preference

This section summarises the survey items which are related to respondents' internet knowledge, experience and preference. Salkind (2000) emphasized that the first step in the data analysis is to describe the data by describing their general characteristics (distribution of data). Information searching process via digital libraries implies that the information needs are processed under the umbrella of using the Internet connectivity. Thus this research emphasizes on the Internet usage mechanism among the academic community through the use of digital libraries.

In the academic community, as expected, the majority of the respondents' primary use of the Internet is for their education or research. This contributes to about 55% followed by as a means of communications (14%). This finding confirms that of a previous study by Uddin (2003). The distribution of the primary intention of using the Internet is tabulated in Figure 4.1, based on university. The figures on the y-axis refer to the percentage of each primary use of internet. Relative to the population sample, UKM and USM showed a higher search of information for personal needs as compared to as a means for communication. All of the four universities show similar distribution of primary use where majority is for education and research, followed by either for communication or personal needs.

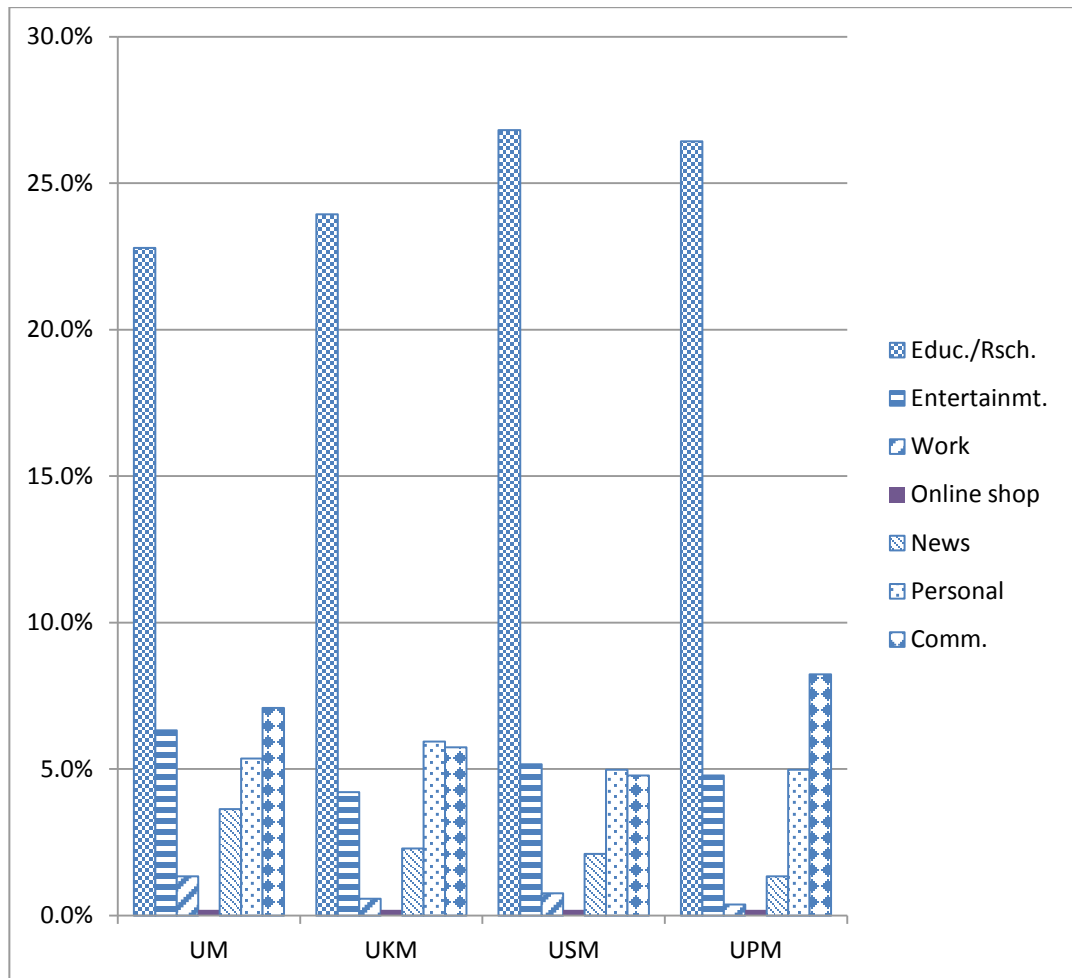

Figure 4.1: Distribution of Primary Use of the Internet, based on University

Another viewpoint to look at is the pattern of purposes of using the Internet according to gender. Figure 4.2 displays these preferences where relative frequency clearly shows both genders, by a majority, were using the Internet for education or research purposes. Interestingly, the male subjects show a slightly higher preference in using the Internet for entertainment as compared to the female subjects. This information provides an early insight of what is the common purposes of using internet. In relation to academic digital libraries this finding may lead to the knowledge of internet usage behaviour between gender of students.

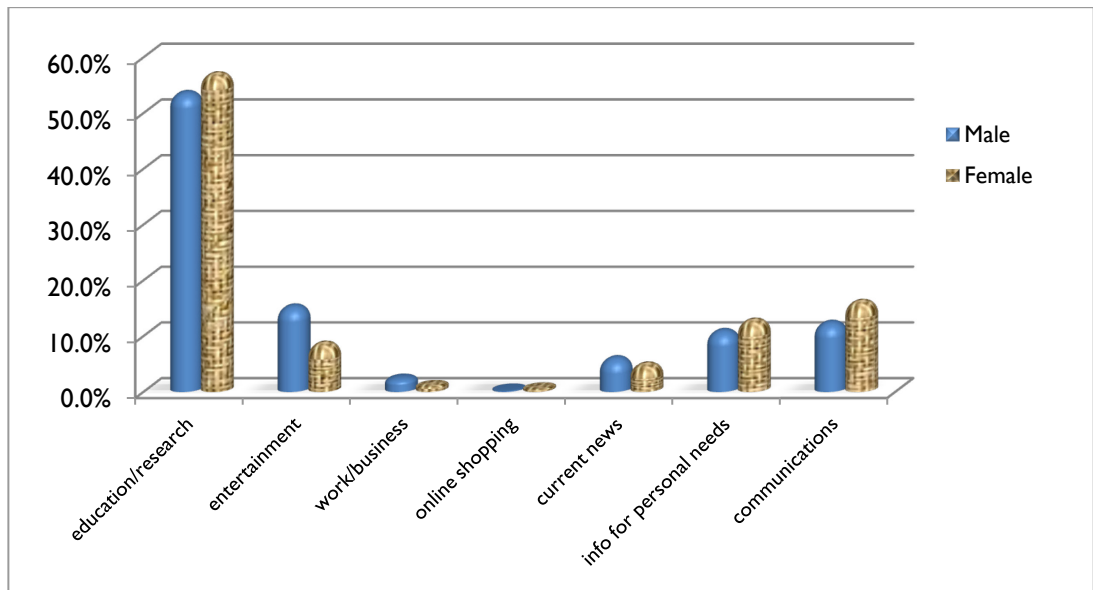

Figure 4.2: Relative Frequency Distribution for Purposes of Using the Internet, by Gender

Internet access in Malaysia, with its advanced state of Information and Communications Technology (ICT) technology, is ubiquitous. The finding from this study reveals that the majority of the respondents *usually* have access to the Internet at the faculty/office (27.7%), home (25.7%) and hostel (24.1%). This is in line with the findings by Uddin (2003) where the preferred place to access the Internet among university academics was the office/department, followed by the home. Although cybercafés are very popular, the subjects of this study might have less preference in going to these venues to study, as the result was low at only about 2%. The results are illustrated in a pie chart in Figure 4.3.

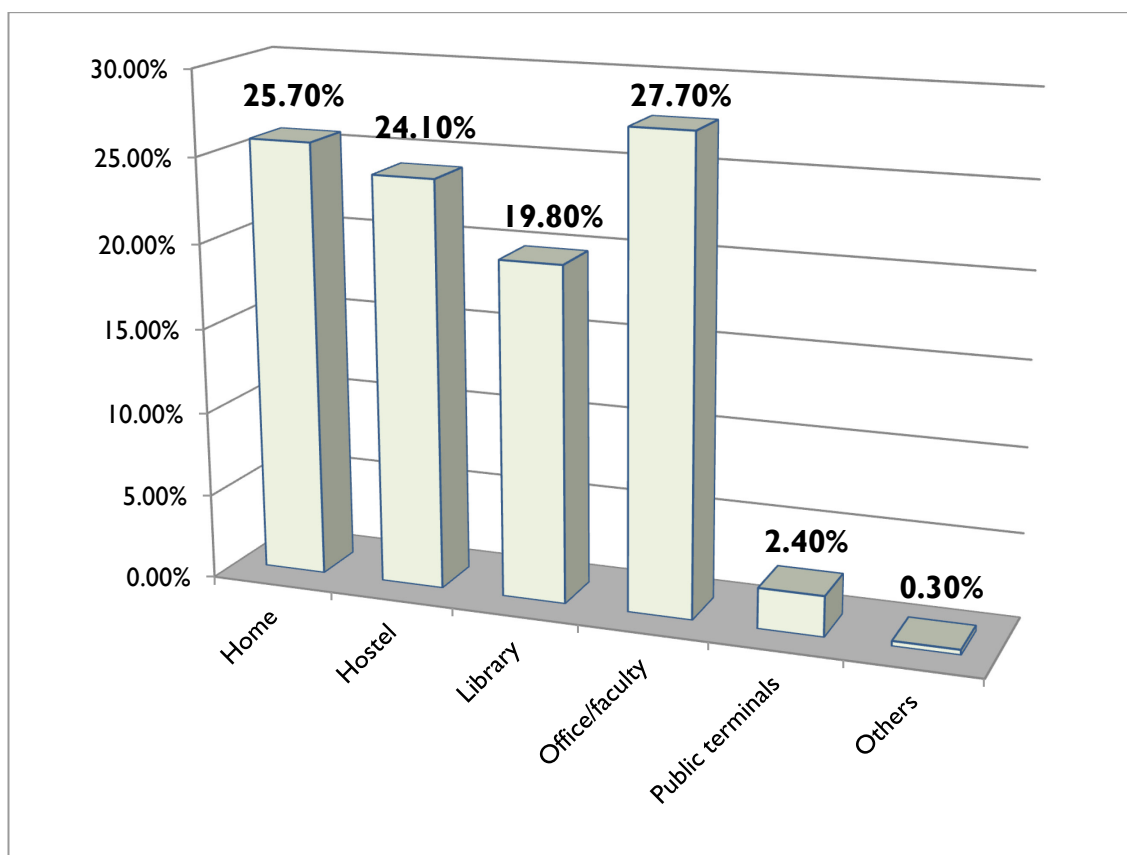

Figure 4.3: Distribution by Place to Access the Internet among Students and Academic Staff

Apart from the statistics for Internet access, this study also explores the Internet or web (literacy) skills among the subjects, however, they were not required to self-rate their skills as in previous studies (Ballantine, McCourt and Oyelere, 2007; Case, MacKinnon and Dyer, 2004; Torkzadeh and Lee, 2003) as cited in Gibbs (2008), since individual perceptions of knowledge and ability in computing may not always relate to the reality. Therefore, this study was most keen to see whether or not their Internet skills actually helped the subjects in accessing digital libraries. These Internet skills are better known in the literature as Internet literacy.

As indicated by Kelly (1999), Internet illiteracy may be the hindrance of greater use of the Internet as a source of information. The results of the study indicate that 93% chose 'Yes' which generally implies the majority of respondents agreed that their

Internet skills did help them better in their information seeking process using online library resources and services. While *no* and *unsure* options were answered by only 1% and 7%, respectively. This finding indicates that users do depend on their Internet knowledge and literacy in order for them to access the information systems such as digital libraries. This result supports the study of Hargittai (2010) who found that the Internet *know-how* is associated with higher levels of Web-use skills.

Only one indicator for measuring the Internet usage was used for this study, that is, frequency of use (Straub, Limayem and Karahanna, 1995; Anakwe, Simmers and Anandarajan, 2002). However, the indicator was modified to reflect Internet usage for general purposes. Respondents were required to estimate the frequency of Internet use with the highest rating scale being *very frequently (daily)* and lowest being *rarely (less than once a month)*. Figure 4.4 shows that about 80% of respondents used the Internet on a daily basis as compared to doing so frequently (weekly, 18%).

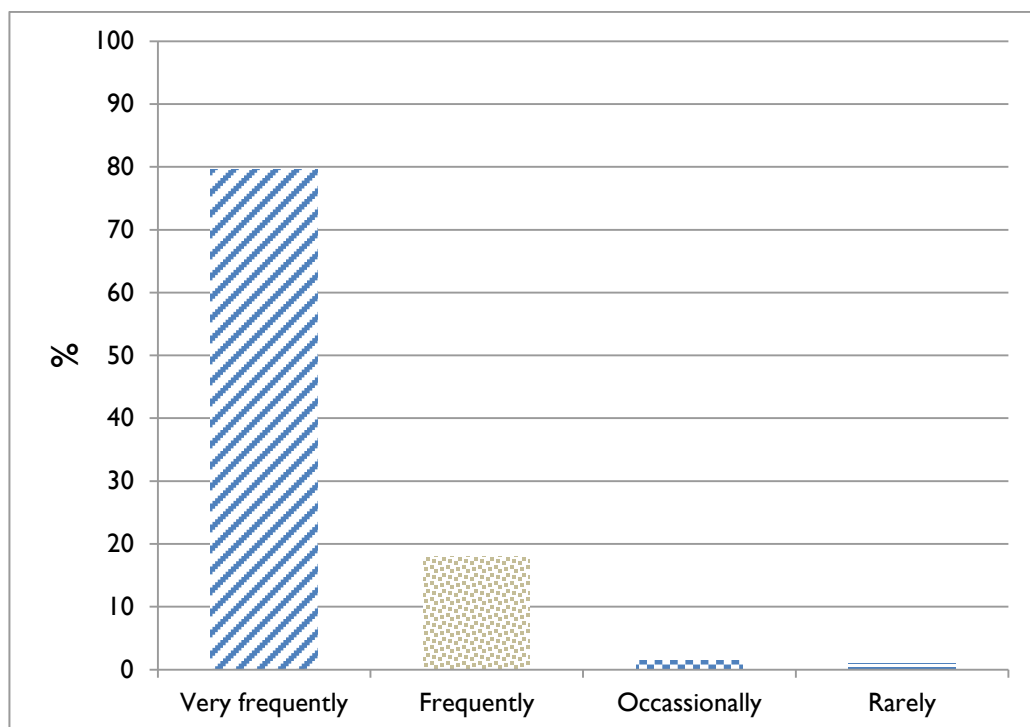

Figure 4.4: Distribution of Internet use among Students and Academic Staff

The discussions on Internet usage which relate to education and research purpose provide information on how respondents associate their Internet skills in accessing Information Systems as part of the knowledge acquisition process. This leads us to the discussion on their awareness of Information Systems, presented in section 4.5.3.

Following the high usage of the Internet as reported in the study, the ensuing analysis is to find out whether respondents would claim if they are frequent users of digital libraries, or otherwise. The responses to the question “I am a frequent user of the university’s digital library” (mean = 3.567, sd = 0.995) is formed into a 5-point Likert scale ranging from strongly disagree to strongly agree. The finding is shown in the Figure 4.5.

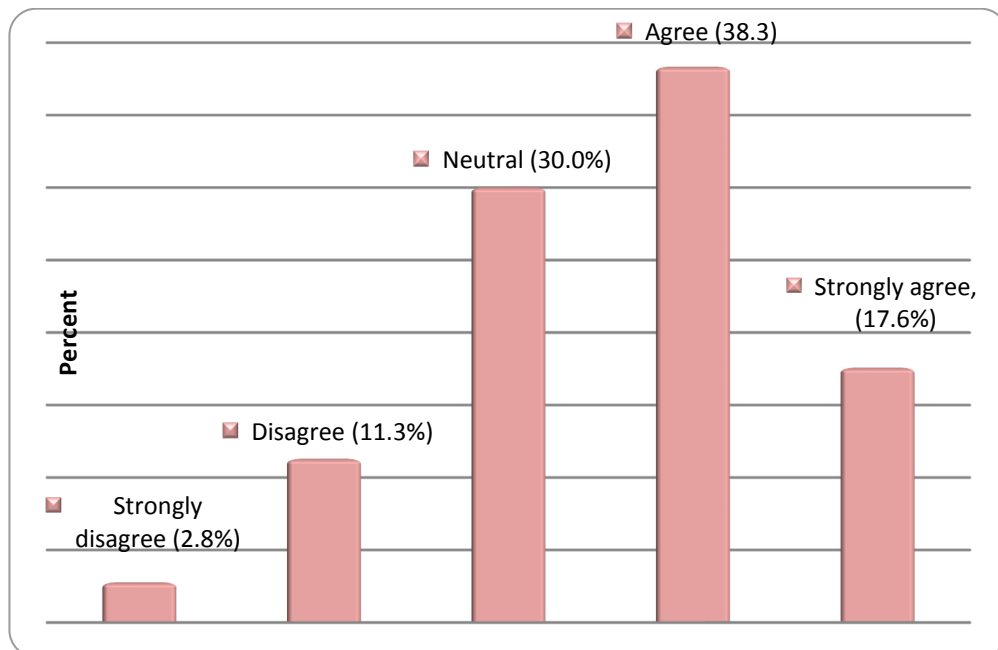

Figure 4.5: Distribution of Response for being a Frequent user of the University’s Digital Library

The result displayed in Figure 4.5 implies that for the positive responses (agree and strongly agree), subjects would likely claim that they are frequent users, as much

as four times more than the negative responses (disagree and strongly disagree). This finding does not only show the propensity of the subjects toward accessing the digital libraries, but also the availability and general importance of digital libraries in higher learning institutions.

In the following section, the results of the measures of association between the selected indicators as used in the study are presented, together with illustrations of the analysis.

4.4.5. Descriptive Statistics of Research Variables

This section provides statistical summaries of the key indicators (variables) of the study sample. Descriptive statistics are intended to reduce data sets to allow for easier interpretation (Wimmer and Dominick, 2001). While Sekaran (2000) noted that this phase of data analysis is to get the sense for the data, where the statistics like means and standard deviations (SD) in the data will give the researcher a good idea how respondents reacted to the items in the questionnaire. The second phase is referred to as inferential statistics, whereby the same results could be inferred or generalised to the society at large.

The proposed research model of Partial Least Squares (PLS) path model consists of seven main formative dimensions by reconciling two theoretical models of the Internet usage for information provisioning and the IS-Impact model. The former model is formed with three dimensions of formative indicators - content breadth, content depth and interaction dynamism, as postulated by Ambrose, Rai and Ramaprasad (2006); while the latter has four dimensions of formative indicators – individual impact, organisational impact, information quality and system quality (Gable, Sedera and Chan, 2008). Specifically, the proposed study model consists of a multidimensional higher order formative measurement model composed of one first-order formative, four

second-order formative and one third-order formative.

All of the descriptive statistics are discussed in the following subsections, starting with the summary of the statistics of indicators for the first-order measurement model.

4.4.5.1 Summary Statistics of Content Breadth (CB)

Content breadth is one of the three first-order formative measures in a Digital Libraries' (DL) Success model. Seven measurement items (indicators) for content breadth dimension shows that the mode and median is 4 (Table 4.5). Since this is an ordinal type data, the mean values may not be useful enough but may show the direction of answers that were responded to. Thus, the summary of the statistics of all the research indicates the values of their median, mode and standard deviation.

Table 4.5: Summary Statistics of Content Breadth Indicators

Indicators	Median	Mode	Standard Deviation (sd)
I obtain academic information about my study.	4	4	0.780
I obtain full text articles as requested.	4	4	0.789
I obtain full text articles from alternative resources.	4	4	0.779
I obtain information as requested.	4	4	0.778
I obtain information as suggested.	4	4	0.775
I obtain internal resources.	4	4	0.757
I obtain worldwide resources.	4	4	0.785

Note: The scale of responses is between 1=strongly disagree and 5=strongly agree

Responses for this dimension shows that respondents are more inclined to agree to all of the CB indicators. This implies that most of the respondents found the digital library

very useful.

4.4.5.2 Summary Statistics of Content Depth (CD)

The second construct for first-order model in the PLS is the content depth. Similar findings are extracted for the content depth dimension. All the five postulated indicators show the values of the responses' median and mode to be 4, with low dispersion.

Table 4.6: Summary Statistics of Content Depth Indicators

Indicators	Median	Mode	Standard deviation
I obtain detailed information	4	4	0.804
I obtain the abstracted information	4	4	0.764
I obtain current information	4	4	0.795
I obtain the archived information	4	4	0.784
I obtain high quality information	4	4	0.820

Note: The scale of response is between 1=strongly disagree and 5=strongly agree

4.4.5.3 Summary Statistics of Interaction Dynamism (ID)

Interaction dynamism is the last dimension of the first-order model. In Table 4.7, only four indicators were used in this dimension, and where all of the modes and medians of the responses were 4. The highest standard deviation (0.915) is for the indicator “*I share academic information with colleagues*” which shows that the responses to this question were dispersed larger than other questions in the same construct.

Table 4.7: Summary Statistics of Interaction Dynamism Indicators

Indicators	Median	Mode	Standard Deviation (sd)
I search for academic information.	4	4	0.835
I request for academic information.	4	4	0.859
I reuse academic information for other tasks.	4	4	0.835
I share academic information with colleagues	4	4	0.915

Note: The scale of response is between 1=strongly disagree and 5=strongly agree

All of the indicators in Tables 4.5, 4.6 and 4.7 were developed as formative measures (independent variables) and in the study they were posited for Individual Usage Impact (IUI), as will be explained in the next section. Prior to that, based on the study by Gable, Sedera and Chan (2008), four dimensions were posited with formative measures in measuring the success of digital libraries, which are measured and constructed for the second-order model. The behaviour of these formative measures is described in the following sections by explaining the summary statistics of Gable, Sedera and Chan's (2008) formative measures from the a-priori model.

4.4.5.4 Summary Statistics of Individual Usage Impact (IUI)

The indicators for Individual Usage Impact (IUI) dimension's summary of the statistics are displayed in Table 4.9. The researcher characterises IUI as an indication that the digital library has given more (or positive impact) room for improvement or enhancement in the respondents' academic knowledge, as all of the three dimensions of DLUIP (first-order) have a positive relationship with IUI (second-order). In the second-order path model, IUI were posited with four indicators. Table 4.8 summarises the responses obtained from the survey.

Table 4.8: Summary Statistics of Individual Usage Impact Indicators

Indicators	Median	Mode	Standard Deviation (sd)
I have learnt much through the presence of the <i>online library resources</i> (academic digital library).	4	4	0.844
The academic digital library improves my awareness of academic tasks	4	4	0.889
The academic digital library improves my study effectiveness.	4	4	0.854
The academic digital library increases my academic knowledge.	4	4	0.822

Note: The scale of responses is between 1=strongly disagree and 5=strongly agree

In general, all of the medians and modes (as shown in Table 4.8) for the indicators of this dimension were found to be 4 and with low deviations of responses. Low deviations indicated that the responses were scattered around the median (or mean) which favour the “agree” responses. This means that the majority of the respondents were inclined towards giving a positive reaction to each of the questions in this dimension.

4.4.5.5 Summary Statistics on Institutional Impact (II)

In contrast to the previous measurement items, Institutional Impact dimensions in this study were measured through the use of a binary variable. In the context of academic digital libraries, the system is not used on behalf of the university or directly to the university’s success but rather for the individuals’ success. The IS-Impact model is validated under the scope of contemporary Enterprise Systems (ES) for companies which made it different from academia. The dimension measures’ aspects incorporated in the study model, such as costing, staffing and productivity, are regarded as a sequence of discrete events that can predict the success of a digital library. These factors

may not be prevalent in the context of digital libraries in academia (as opposed to business organizations) but are still necessary for digital library success evaluation. This is based on the process theories by Mohr (1982) who emphasized that the independent variable is assumed to be insufficient to “cause” the dependent variable (outcome), but it is held to be necessary for the outcome to occur. Since the main aim of this study is the overall evaluation of the success of academic digital libraries (and not ES), it is necessary to characterise the indicators for Institutional Impact as discrete events (yes vs. no). Thus, only the academic staff, librarians and IT officers were approached to answer the questions related to this dimension. Due to confidentiality considerations based on the expert reviews, eight success measures were used for this dimension.

A summary of the statistics in Table 4.9 displayed the preference for the “yes” option for all of the indicators except for “*the academic digital library has resulted in reduced staff cost*”. The findings were supported by the responses given during the interview session where a majority of them pointed out that maintaining and sustaining academic digital libraries required more trained staff and thus more staff cost. Most of the library budget is spent on staff training both in hardware as well as software. This could be the reason why the values of the median and mode for this item were negative.

Table 4.9: Summary Statistics on Institutional Impact Indicators

Indicators	Median	Mode	Standard Deviation (sd)
The academic digital library is cost effective.	1	1	0.298
The academic digital library has resulted in reduced staff cost.	0	0	0.455
The academic digital library has resulted in overall cost reductions (administration, hardware, software & etc).	1	1	0.494
The academic digital library has resulted in overall improvement in library services.	1	1	0.000
The academic digital library has resulted in improved outputs for academic users.	1	1	0.000
The academic digital library has resulted in increase of capacity to manage the growing volume of activity (e.g. transactions of searching, retrieving & etc.)	1	1	0.239
The academic digital library has resulted in an improved library process and use.	1	1	0.366
The academic digital library has resulted in better positioning for research universities.	1	1	0.000

Note: The response is a direct measure of 1=Yes, 0=No, treated as a discrete-event.

4.4.5.6 Summary Statistics of Information Quality (IQ)

The summary of the statistics for the Information Quality dimension is shown in Table 4.10. Similar results (as produced by IUI indicators) were obtained for the Information Quality dimension, i.e., the majority of the responses favoured the “agree” option. Such a pattern of response implies the high quality of information served by academic digital libraries. All the deviations from the middle responses were found to be low for all indicators.

Table 4.10: Summary Statistics of Information Quality Indicators

Indicators	Median	Mode	Standard Deviation (SD)
Information available from the academic digital library is important.	4	4	0.827
The information needed is always available.	4	4	0.837
The academic digital library provides output is what is exactly is needed.	4	4	0.846
Information from the academic digital library is readily usable.	4	4	0.905
Information from the academic digital library is easy to understand.	4	4	0.761
Information from the academic digital library is always timely.	4	4	0.848
Though data from an academic digital library is accurate, outputs sometimes are not.	4	4	0.781
Information from the academic digital library is concise.	4	4	0.776
Information from the academic digital library is readable, clear and well-formatted.	4	4	0.819
Information from the academic digital library is unavailable elsewhere.	4	4	0.754

Note: The scale of response is between 1=strongly disagree and 5=strongly agree

4.4.5.7 Summary Statistics of System Quality (SQ)

In contrast, the System Quality (SQ) dimension shows mixed results, as demonstrated in the following table.

Table 4.11: Summary Statistics of System Quality Indicators

Indicators	Median	Mode	Standard Deviation (SD)
Data from the academic digital library often needs correction.	3	4	0.799
Data from the academic digital library is current enough.	4	4	0.844
The academic digital library is missing key information.	3	4	0.890
The academic digital library is easy to use.	4	4	0.766
The academic digital library is easy to learn.	4	4	0.909
Often difficult to get access to information in the academic digital library	3	4	0.834
The academic digital library meets my (academic) requirement.	3	3	0.764
The academic digital library includes necessary features and functions.	4	4	0.754
The academic digital library always does what it should.	4	4	0.817
The academic digital library user interface can be easily adapted to one's personal approach.	4	4	0.824
The academic digital library is always up-and-running as necessary.	4	4	0.759
The academic digital library system responds quickly enough.	3	4	0.908
The academic digital library requires a minimum number of fields and screens to achieve task.	3	3	0.725
All data within the academic digital library is fully integrated and consistent.	4	4	0.809
The academic digital library can be easily help me dealing with errors.	3	4	0.805

Note: The scale of response is between 1=strongly disagree and 5=strongly agree

In Table 4.11 only two indicators were found with a mode of 3 (“neutral” scale) i.e. (1) “the academic digital library meets my (academic) requirement” and (2) “the academic digital library requires a minimum number of fields and screens to achieve task”. The results imply that many users are prone to give nonaligned answers towards these two aspects which portray users’ neutral perception. Furthermore, these two indicators

displayed a median of 3, alongside with six other indicators, while the rest of the indicators had “agree” responses.

4.4.5.8 DL Success Dependent Variables

In the proposed study model, the DL Success is defined by the indicators and the constructs of the Individual Usage Impact (IUI), Institutional Impact (II), Information Quality (IQ) and Service Quality (SQ). These are all independent variables of the second-order model that were hypothesised to cause the third-order measure, the DL Success. In capturing the global measure of the full model, the DL Success construct consists of four dependent variables (formative measures), as suggested by Gable, Sedera and Chan (2008):

- i. Overall, the impact of the academic DL for me has been positive.
- ii. Overall, the impact of the academic DL on the institution has been positive.
- iii. Overall, the information quality of the academic DL is satisfactory.
- iv. Overall, the system quality of the academic DL is satisfactory.

Table 4.12 provides the summary of the four measures.

Table 4.12: Summary of the Statistics of the Four Formative Measures (dependent variables) of the DL Success Model

Indicators	Median	Mode	Standard Deviation (SD)
Overall, the impact of the academic DL for me has been positive.	4	4	0.837
Overall, the impact of the academic DL on the institution has been positive.	4	4	1.000
Overall, the information quality of the academic DL is satisfactory.	3	3	0.991
Overall, the system quality of the academic DL is satisfactory.	3	4	0.845

Note: The scale of response is between 1=strongly disagree and 5=strongly agree

The mode of the overall IQ is 3, in contrast to the other three measures. Nonetheless, the medians of the overall IQ and SQ show a value of 3, which is lower than the overall IUI and II measures. In addition, the standard deviation (SD) for overall II is noted to be the highest among all of the four measures. This implies a large dispersion of the responses received in the survey questionnaires.

Having discussed the behaviour of the independent and dependent variables of the study, the following section presents the inferential statistics of the selected measurement items in the questionnaire with some demographic factors.

4.5. Measures of Association and Relationship between Indicators

This section presents the findings of the inferential statistics of the research data in terms of association and direction as well as the strength of relationship between the indicators of the study. It is categorized into three main subsections, the Internet literacy skills, the Internet usage and awareness of digital libraries; in relation to demographic factors. The summary of the statistics (in brackets) is presented for each item measurement.

Internet literacy skills (mean=1.14, sd=0.505, n=942): This indicator does not directly measure the self-rated skill of using the Internet but rather on whether the Internet literacy skills possessed by respondents can help them better in using their university's digital library. It is a multiple choice response with 1= "yes", 2= "no" and 3 = "not sure".

The Internet usage (mean=1.24, sd=0.519, n=943): Using a 5-rating scale, very frequently (daily) to rarely (less than once a month), this indicator measures the frequency of using the Internet.

The awareness level of digital library: Level of awareness of digital libraries is treated as moderating variables in the study model. It is measured with 5 ratings, scaled from

strongly unaware (or very unfamiliar) to strongly aware (or very familiar). Ten questions related to the awareness of digital library were asked in the questionnaire, with Cronbach's Alpha of 0.911. The items included:

- Aware and use the digital library for study/research (*mean* = 3.93, *sd* = 0.842, *n* = 941).
- Aware of the digital library functionalities (*mean* = 3.94, *sd* = 0.813, *n* = 942).
- Aware of access to the university's past theses/articles (*mean* = 3.89, *sd* = 0.879, *n* = 939).
- Aware that colleagues are also using the digital library (*mean* = 3.67, *sd* = 0.931, *n* = 942).
- Aware of the importance of the digital library for study/research (*mean* = 4.11, *sd* = 0.784, *n* = 940).
- Aware that the digital library can provide the required journals/periodicals (*mean* = 3.99, *sd* = 0.835, *n* = 941).

4.5.1. Internet Literacy Skills and Demographic Profiles

This sub-section reports the analyses of the association between demographic profiles (gender, age, race and university) and the Internet knowledge/literacy skill that can help the users to improve their skills and save time by using academic digital libraries. This part of the analysis only considered students and academic staff (with exception of librarians and IT officers) with $n=944$. The objective is to study any discrepancy between observed frequency and expected frequency, if the Internet literacy and demographic profiles are not associated. Chi-square analysis was used to undertake this measure of association analysis (nominal and ordinal variables). All of the tests were conducted at the 0.10% level of significance.

4.5.1.1 Internet Literacy and Gender

Cross tabulation output as produced by SPSS software is exhibited in Table 4.13. This population for the analysis is n=942, with two responses missing. At a glance, a higher number of female respondents (more than 93%) tended to respond more confidently that the Internet literacy skills they possessed helped them better in using the university's academic digital library, as compared to male respondents (about 90%). However, this pattern of responses may not be sufficient to show that the difference is really due to gender difference. The analysis proceeds with the report of the Chi-square test.

Table 4.13: Cross Tabulation of Responses, by Internet Literacy Skill and Gender

Measurement	Response	Gender		
		Male	Female	Total
Internet literacy skill helps better in using online library resources (digital library)	Yes	371	497	868
	No	8	4	12
	Not sure	30	32	62
	Total	409	533	942

The test results show that there is no association between gender and the Internet literacy skills, at 0.10% significance level ($\chi^2 = 3.425$, $df=2$, $p\text{-value}=0.18$). This indicates that gender does not determine a better use of digital libraries. Thus, the slight difference between the responses of male and female subjects can be concluded as due to chance. In contrast, the findings of some international studies showed inequalities exist between gender and dimensions like experience, skills and types of Internet use (DiMaggio et al., 2004; Hargittai, 2010), this study differs in the aspect of relating the Internet skills to using information systems such as academic digital libraries.

4.5.1.2 Internet Literacy and Age

Another aspect of demographic profile chosen was age. With n=941, the older age groups show greater confidence that the Internet skills can help them in using the digital library better. The < 25-year old age group showed a “Yes” response rate of below 90% as compared to other older age groups (Table 4.14). Early assumptions based on the high number of “Yes” responses between the age groups may imply that there is a relationship between the Internet literacy skills and age. To test the independence between age groups and the Internet literacy skill, a chi square test was done. The results are $\chi^2 = 21.629$, $df = 10$, $p\text{-value} = 0.017$ (where $p < 0.10$) and thus concludes that there is a significant relationship between the Internet literacy skill and age.

Table 4.14: Cross Tabulation of Responses, by Internet Literacy Skill and Age

Measure	Response	Age						Total
		<25yrs	25-29yrs	30-34yrs	35-39yrs	40-44yrs	>45yrs	
Internet literacy skill helps better in using online library resources (digital library)	Yes	512	112	51	84	61	47	867
	No	8	3	0	0	1	0	12
	Not sure	51	8	2	1	0	0	62
	Total	571	123	53	85	62	47	941

A further analysis is to test the strength of this relationship. The Chi-square test may reveal the dependency between two categorical variables, but it does not quantify the strength of the relationship. As provided by SPSS, symmetric and directional tests measure the strength relationship that exists between age and the Internet literacy skill. Although chi-square test shows that there is a statistically significant relationship between these variables, the relationship is weak. Phi coefficient, Cramer’s V and the contingency coefficient show the values of < 0.20 , which indicate a very weak

relationship. Each of the measures may take a value between -1 and 1 where, absolute value closer to 0 indicates a weak relationship.

4.5.1.3 Internet Literacy and Race

Cross tabulation between the Internet literacy skills and race is as displayed in Table 4.15 (n=938). The majority of responses were affirmative (“Yes”) for all ethnicities. But the chi-square test of independence indicates that $p > 0.10$, where it can be concluded that there is no relationship between these two variables ($\chi^2 = 8.368$, $df = 6$, $p\text{-value} = 0.212$). These findings imply that the Internet literacy skill helps respondents better in using the digital library, regardless of their ethnicity.

Table 4.15: Cross Tabulation of Responses, by Internet Literacy Skill and Ethnicity

Measure	Response	Race				
		Malay	Chinese	Indian	Others	Total
Internet literacy skill helps better in using online library resources (digital library)	Yes	553	162	31	118	864
	No	6	4	0	2	12
	Not sure	34	18	0	10	62
	Total	593	184	31	130	938

4.5.1.4 Internet Literacy and University

The study also aimed at finding out if there is a difference of the Internet literacy skills that can help respondents better in using the digital library among the four research universities. A cross tabulation of the response pattern is shown in Table 4.16 (with $n = 942$). Again, the chi-square test reveals no association between the two variables, with $\chi^2 = 3.744$, $df = 6$ and $p\text{-value} = 0.717$.

Table 4.16: Cross Tabulation of Responses, by Internet Literacy Skill and University

Measure	Response	University				
		UM	UKM	USM	UPM	Total
Internet literacy skill helps better in using online library resources (digital library)	Yes	221	213	214	220	868
	No	4	2	3	3	12
	Not sure	18	9	17	18	62
	Total	243	224	234	241	942

From these four tests of relationships between the Internet literacy skills helping respondents to use digital libraries better and demographic profiles (age, gender, ethnicity and university), it was found that only gender showed a relationship, though a weak one. The next section presents the findings of the relationships between the Internet usage and demographic profiles.

4.5.2. Internet Usage and Demographic Profiles

Demographic profiles such as age and education are said to be dominant predictors of varied Internet usage (Jones and Fox, 2009; Hargittai and Hinnant, 2008). Thus this section denotes the analysis of the testing of the relationships between demographic variables (age, gender, ethnicity and university) and the Internet usage. The usage measurement used in the study ranged from 1=very frequently (daily) to 4=less than once a month (rarely).

4.5.2.1 Internet Usage and Gender

The responses (n=943) from the study surveys are displayed in Table 4.17. It clearly shows that the majority of the respondents used the Internet on a daily basis (about 79% for each group of the female and male respondents). However, there were no clear indications of differences between the observed responses and expectations, when the

Internet usage and gender were not related. Thus, the Chi-square test of independence for categorical data was again applied.

Table 4.17: Cross Tabulation of Responses, by Internet Usage and Gender

Measure	Response	Gender		
		Male	Female	Total
Internet usage	Daily	325	425	750
	Weekly	73	97	170
	Monthly	8	6	14
	Rarely	4	5	9
	Total	410	533	943

The chi-square analysis for testing the independence between the Internet usage and gender of respondents revealed that the Internet usage is not influenced by gender of respondents ($\chi^2 = 1.094$, $df = 3$ and $p\text{-value} = 0.779$). This result supports that of previous studies where the gender divide in the Internet use is narrow (Odell et al., 2000; Luan, Fung and Atan, 2008). This is also found in the study by Hargittai (2010), supporting Ono and Zavodny (2003), that sex inequalities in the Internet usage are getting lesser concerns now and, this could be due to the widespread Internet access and facilities.

4.5.2.2 Internet Usage and Age

Another important demographic indicator for this study is age of the respondents. Hargittai (2008) emphasised that the Internet use should be of interest to scholars of social stratification. However, this study limits the analysis of basic demographic profiles like age without taking into account respondents' socioeconomic factors.

A cross tabulation of responses for the Internet use and age is shown in Table

4.18. Based on the chi-square test ($\chi^2 = 24.580$, $df = 15$ and $p\text{-value} = 0.056$), there is evidence of a statistically significant relationship between the Internet usage and age ($p < 0.10$).

Table 4.18: Cross Tabulation of Responses, by Internet Usage and Age

Measure	Response	Age						Total
		<25yrs	25-29yrs	30-34yrs	35-39yrs	40-44yrs	>45yrs	
Internet usage	Daily	430	108	45	70	52	44	749
	Weekly	122	15	7	14	9	3	170
	Monthly	13	0	1	0	0	0	14
	Rarely	7	0	0	1	1	0	9
	Total	572	123	53	85	62	47	942

Further analysis was performed to determine the strength of the relationship of the two ordinal variables. Symmetric measures of Kendall's tau_b and Gamma indicate values of less than -0.30. The negative value implies that a negative relationship (direction) exists: the higher the age group, the lesser the Internet usage. This result is consistent with the study by Lazinger, Bar-Ilan and Peritz (1997). By the virtue of age, undergraduates fall in the younger age group and this may affect the high Internet usage in accomplishing assignments and projects in each semester. This finding also reveals that the relationship is weak (less than -0.5).

4.5.2.3 Internet Usage and Ethnicity

One other aspect of demographic characteristic considered in this study is ethnicity. Table 4.19 tabulates the usage response pattern by ethnicity (n=939).

Table 4.19: Cross Tabulation of Responses, by Internet Usage and Ethnicity

Measure	Response	Race				
		Malay	Chinese	Indian	Others	Total
Internet Usage	Daily	477	138	24	107	746
	Weekly	103	38	6	23	170
	Monthly	8	5	0	1	14
	Rarely	5	3	1	0	9
	Total	593	184	31	131	939

The chi-square test however revealed that the difference between the observed and expected responses by ethnicity is due to chance with $p > 0.10$. This indicates no relationship exists between the Internet usage and ethnicity ($\chi^2 = 8.246$, $df = 9$ and $p\text{-value} = 0.510$).

4.5.2.4 Internet Usage and University

One of the aims of the analysis is to see if there is a difference in the Internet usage among the universities. The indicator of the Internet usage was conceptualised in the form of frequency of using the Internet (ordinal variable). The test used here is the Kruskal-Wallis test, meant for a one-way analysis of variance using ranks and suitable for ordinal variables. This means that the approach did not use the original values but the ranks instead. The null hypothesis for this test is K independent samples (in this study $K=4$) from the same population. The indicator of the Internet usage using frequency has mean = 1.24 and sd = 0.519, with $n=943$. The tabulation of responses obtained from the survey is displayed in Table 4.20. The mean rank and chi-square statistics are also included.

Table 4.20: Cross Tabulation of Responses, by Internet Usage and University

Indicator	Response	University				Total
		UM	UKM	USM	UPM	
Internet Usage	Daily	194	202	200	154	750
	Weekly	44	20	34	72	170
	Monthly	3	1	0	10	14
	Rarely	3	1	0	5	9
	Total	244	224	234	241	943
Mean ranks		472.17	421.55	442.34	547.52	
$\chi^2_{0.10, 3}$		59.038				
p-value		0.000*				

Note: * $p < 0.100$

UM - Universiti Malaya

UKM - Universiti Kebangsaan Malaysia

USM - Universiti Sains Malaysia

UPM - Universiti Putra Malaysia

Of the four universities, UPM shows the highest rank in terms of the Internet usage, followed by UM. The finding of the analysis indicates evidence of statistical difference in the Internet usage among the universities. Although there is a relationship between these two variables, the relationship is not strong. The value of Kendall tau_b and Gamma produced are all less than 0.30 which indicates a weak relationship. Each university has a variety of faculties with different missions and visions, thus the frequency of using the Internet may vary from one university to another. The ensuing procedure is to further cross-classify which universities have a significant relationship between Internet usage and university by taking into account the academic faculties. The results are as shown in Table 4.21.

Table 4.21: Statistical Tests and Results for Test of Independency between the Internet Usage and University

University	Chi-square Test	Strength of Relationship	Directional Measures (Theil's U)
UM	$\chi^2 = 47.887$, df = 48, p-value = 0.447	-	-
UKM	$\chi^2 = 29.866$, df = 42, p-value = 0.920	-	-
USM	$\chi^2 = 21.391$, df = 14, p-value = 0.092*	Weak**	Internet usage = 0.114** Faculty = 0.020**
UPM	$\chi^2 = 68.810$, df = 45, p-value = 0.013*	Moderate strong**	Internet usage = 0.163** Faculty = 0.058**

Note: * $p < 0.10$, ** $p < 0.05$

UM - Universiti Malaya

UKM - Universiti Kebangsaan Malaysia

USM - Universiti Sains Malaysia

UPM - Universiti Putra Malaysia

As shown in Table 4.21, only two universities have a statistically significant relationship with Internet usage, namely USM and UPM. Looking at the strength of the relationship for both of these universities, it is clear that UPM has a moderately strong relationship with a Phi coefficient value of 0.54. Despite having dependency between USM and Internet usage, it is a weak relationship. Theil's U statistic measures the error when predicting responses for Internet usage/faculty when the value of the faculty/Internet usage is known. For both USM and UPM, misclassification reduction occurs below 16%.

Many universities have embarked on expanding their information technology (IT) facilities and are continuously promoting Internet use in university education (Huang et al., 2004; Pahl, 2003; Chandler, 2002). While Straub, Loch and Hill (2001) stressed that culture and social norms play an important role in shaping Internet usage. This study however reveals that only age and university contribute to the difference in the Internet usage pattern among the users. Other demographic profiles such as gender

and ethnicity were not significant. As noted by Bimber (2000), gender gap may exist in the Internet use patterns by incorporating socioeconomic factors. Further analysis reveals that only two universities showed a significant relationship, after taking academic faculties into account. This finding implies that the dependency on the Internet usage occurs only among students and academicians at USM and UPM. In addition, UPM shows a moderately strong relationship.

Brown (1994) suggested that lack of awareness of the information resources on the Net and, of the skills to locate the specific information required, may lead to a low usage of the Internet. This indicates that higher awareness may drive the high Internet usage. With respect to this, awareness among users of particular information resources or networked information systems like digital libraries may have influenced the usage and perception of using and accepting such systems. The following discussion proceeds with an investigation of the level of awareness among students and academicians on academic digital libraries, awareness of their services and features, and to find out the relationship between awareness of the Internet usage and demographic profiles.

4.5.3. Usage Awareness of Digital Libraries

The underlying assumption from previous studies (e.g., Brown, 1994) is that higher awareness of an information system may lead to high Internet usage and so forth, implying high usage of digital libraries. This study however investigated the awareness and usage awareness of digital libraries among respondents. Schmidt (2002) highlighted that awareness has taken up many meanings and interpretations, and it is highly dependent on the context for which it is used. This study however focuses on the level of awareness on the digital library while usage awareness refers to how respondents are aware of the services and functionalities that digital libraries provide in terms of academic information. In the following sub-sections, the results of association between

the variables of interest that relate to the aspect of awareness are discussed.

4.5.3.1 Level of Awareness of Digital Libraries

The discussion on the level of awareness begins with the distribution of responses on the awareness of digital libraries. Table 4.22 shows that almost three quarters of the respondents were aware of digital libraries. More than half (about 53%) reported that they were aware of digital libraries, while about 19% admitted they were very aware. This finding suggests a high awareness of such resources among students and academicians. This finding is in line with Veeramani and Vinayagamoorthy (2010).

Table 4.22: Awareness of the Digital Library

Scales	Frequency	Percent
Very unaware	10	1.1
Unaware	32	3.4
Neutral	219	23.2
Aware	498	52.8
Very aware	183	19.4
Missing	2	0.2
Total	944	100

Furthermore, the number of respondents who were aware of and use digital libraries was also as high in the next finding. The results are as displayed in the following table.

Table 4.23: Awareness of and Use of the Digital Library

Scales	Frequency	Percent
Very unaware	10	1.1
Unaware	51	5.4
Neutral	158	16.7
Aware	502	53.2
Very aware	220	23.3
Missing	3	0.3
Total	944	100

Results in Table 4.23 indicate that more than three quarters of the respondents claimed that besides being aware of the existence of their respective university’s digital library, they had also used the digital library to gain online resources. Both findings indicate the high awareness of the existence of online library resources in supporting academic activities among the respondents. Although the term “digital library” may be abstracted from many definitions, most of the students and academicians have begun to accept Information Systems such as online library resources as part of the academic digital library.

The following table presents the results of the digital library usage as compared to traditional library, to the question “*I use the university’s online library resources more than the physical library resources*”.

Table 4:24: Distribution of DL Usage as Compared to Physical Library

Scales	Frequency	%
Strongly disagree	31	3.3
Disagree	101	10.7
Neutral	277	29.3
Agree	346	36.7
Strongly agree	186	19.7
Missing	3	0.3
Total	944	100

From the table, only less than a quarter (14%) of the respondents disagreed and strongly disagreed. This figure might indicate that they use the physical library more than the digital library, or they do not use the digital library. However, the number of respondents who claimed they used the digital library more than the traditional library is four times higher (56.4%).

The first awareness concept as described by Hansen and Järvelin, (2005) is *awareness of people*. This class of awareness was asked in two questions. The first was

“I am aware that my colleagues are also using the digital library”, and the second was “I am aware that my study/research group needs the digital library rather than any other search engines”. The results of both questions are provided in Table 4.25.

Table 4.25: Awareness of People

Scales	Awareness of colleagues using the Digital Library (DL)		Awareness of study/research group needs on the Digital Library (DL)	
	Frequency	%	Frequency	%
Strongly disagree	25	2.6	15	1.6
Disagree	73	7.7	65	6.9
Neutral	243	25.7	256	27.1
Agree	445	47.1	444	47.0
Strongly agree	156	16.5	162	17.2
Missing	2	0.2	2	0.2
Total	944	944	944	100

Table 4.25 indicates that both classes of “awareness” mostly agreed and strongly agreed. These two responses showed that about 64% of the respondents were aware of their colleagues using the digital library.

In the following table, the results of the second concept of awareness i.e. *awareness of object* are presented, measured by two items: “I am aware I can access the university’s past scholarly theses/articles through the digital library” and “My main intention of using the university’s digital library is to find academic information from online journals/periodicals/etc.”

Table 4.26: Awareness of Object

Scales	Awareness of access of past theses using the Digital Library (DL)		Awareness of finding academic information through the Digital Library (DL)	
	Frequency	%	Frequency	%
Strongly disagree	13	1.4	10	1.1
Disagree	51	5.4	37	3.9
Neutral	187	19.8	163	17.3
Agree	460	48.7	476	50.4
Strongly agree	228	24.2	255	27.0
Missing	5	0.5	3	0.3
Total	944	944	944	100

Seven percent (7%) of the respondents claimed that they disagreed and strongly disagreed with being aware of accessing past theses from their university's digital library. However, only five percent (5%) gave such a negative response to the awareness of using the digital library to find academic information. On the other hand, in both cases of awareness, very high percentages were shown for positive responses (agree and strongly agree). Slightly above three quarters (77%) of the respondents positively responded to being aware of using the digital library for finding academic information from the online journals, articles and so on, while 72.9% claimed they were aware of accessing past scholar's theses or articles through the digital libraries.

The last concept of awareness was defined in the two measurement items of *awareness of activities*. They were “*I am aware of what features and capabilities of the digital library that can help me in my study/research*” and “*I am aware that I can use the digital libraries for my education/research information needs*”. Table 4.27 presents the results.

Table 4.27: Awareness of Activities

Scales	Awareness of the capabilities of the Digital Library (DL) to assist in study/research		Awareness of the usage of the Digital Library (DL) for education/research needs	
	Frequency	%	Frequency	%
Strongly disagree	9	1.0	7	0.7
Disagree	40	4.2	25	2.6
Neutral	165	17.5	126	13.3
Agree	509	53.9	482	51.1
Strongly agree	219	23.2	300	31.8
Missing	2	0.2	4	0.4
Total	944	944	944	100

With about 77% of respondents had agreed and strongly agreed that they were aware of the capabilities of the digital libraries in assisting their study or research, and this indicates overall high awareness. Moreover, about 83% of the respondents gave a positive response on their awareness of using the digital library in meeting academic information requirements. In contrast, only less than five percent provided negative responses.

Based on the findings of the three formal classes of awareness, awareness of people, awareness of objects and awareness of activities; all showed high awareness of the digital libraries in fulfilling academic users' needs. Thus the findings indicate that the study sample showed high awareness of the capabilities of academic digital libraries in assisting them in their academic / research routines.

In the following section, the relationship between the levels of awareness of the digital library was investigated with demographic profiles (gender, age, ethnicity and faculty). The analysis was carried out with the purpose of providing insights on the influence of demographic factors to the DL awareness level.

4.5.3.2 Awareness of Digital Libraries and Demographic Profiles

This section proceeds with a discussion about the relationship between levels of awareness and demographic characteristics of the respondents namely gender, age, ethnicity and faculty. The hypothesis formulated showed that there is no relationship between level of awareness and demographic profiles, which was tested using the chi-square test. The results are as displayed in the following table.

Table 4.28: Statistical Tests and Results for Test of Independence between Digital Library Awareness and Demographic Profiles

Demographic Profiles	Chi-square test	Strength of Relationship	Directional Measures
Gender	$\chi^2 = 11.208$, df = 4, p-value = 0.024*	Very weak**	Awareness = 0.005** Gender = 0.009**
Age	$\chi^2 = 84.011$, df = 20, p-value = 0.000*	Weak**	Awareness = 0.041** Age = 0.038**
Ethnicity	$\chi^2 = 28.920$, df = 12, p-value = 0.004*	Very weak**	Awareness = 0.012** Race = 0.015**
University	$\chi^2 = 37.276$, df = 12, p-value = 0.000*	Very weak**	Awareness = 0.018** University = 0.015**

Note: * $p < 0.10$, ** $p < 0.05$

Findings from the analysis above suggest that the demographic profiles of gender, age, ethnicity and university have significant associations with the level of awareness of digital libraries. Among all these, age shows the highest Phi coefficient (with 0.038), however, it is still not a strong relationship. Thus it is safe to indicate the evidence of relationship between those factors with a level of awareness of digital library but with a weak relationship.

4.5.3.3 Awareness of Digital Libraries and Internet Usage

The cross-tabulation of responses for awareness of digital libraries by Internet usage is shown in Table 4.29.

Table 4.29: Cross Tabulation of Responses of Awareness of Digital Libraries and Internet Usage

Measure	Response	Internet Usage				
		Daily	Weekly	Monthly	Rarely	Total
Awareness of Digital Libraries	Very unfamiliar	9	1	0	0	10
	Unfamiliar	41	8	1	1	51
	Neutral	106	45	3	3	157
	Familiar	403	89	6	4	502
	Very familiar	189	26	4	1	220
	Total	748	169	14	9	940

The responses in Table 4.29 clearly shows that a majority of the respondents are very familiar with the awareness and the usage of digital library as the figure is shown in the bottom left cells of the rows and columns. Skimming the figures may lead to the early finding that the more the awareness (or familiarity), the more frequent the use of the Internet. To support this finding, a chi-square test was done to test the association between these two indicators.

The chi-square results indicate the evidence of highly statistically significant (with $p < 0.10$) relationship between level of awareness of digital libraries and Internet usage ($\chi^2 = 22.985$, $df = 12$, $n = 941$ and $p\text{-value} = 0.028$). However, the relationship is not that strong since Kendall's tau_b (the symmetric measure) shows a low value of -0.151 and Gamma with -0.340; both are still considered as low. The negative direction of the relationship implies that the higher the awareness, the higher the Internet usage.

The finding is in line with Brown (1994) who stated that awareness could become a factor that affect the usage pattern of the Internet.

4.5.3.4 Awareness of Digital Libraries and Internet Skills

In conjunction with self-rated Internet abilities and skills that may help in using the digital library better, this analysis attempted to find out its relationship with the level of awareness that the respondents claimed to have. A chi-square test of independency ($\chi^2 = 37.828$, $df = 8$, $p\text{-value} = 0.000$) indicates the rejection of the null hypothesis (no relationship between the two variables). This suggests that there is evidence that the level of awareness and Internet skills do help in using digital libraries better.

The strength of the relationship quantified using Gamma shows a moderate relationship (-0.497) between these two variables, thus suggesting awareness of a system is a significant indicator for developing skills in using such systems in academia.

4.5.3.5 Awareness of Digital Libraries' Functionalities and Demographic Profiles

Apart from the level of awareness of digital libraries, this section focuses on the awareness of digital library functionalities which includes its services and features that can help respondents in their study and research. Among such services and features are the availability of online journal and reference databases, online books, online theses, and digital repository.

Awareness of services and features of an Information System may steer one's interest and preference towards using or accepting the system as part of his/her academic needs. A study by Luan, Fung and Atan. (2008) on attitudes towards preference for Internet functionalities (for information, social and leisure purposes) using a sample of student teachers of the Faculty of Educational Studies, Universiti Putra Malaysia (UPM) revealed that there is no significant difference in attitudes

between gender.

Table 4.30 exhibits the statistical test results of the relationship between awareness of digital library functionalities and demographic profiles (gender, age, ethnicity and university).

Table 4.30: Statistical Test for Relationship between Awareness of Digital Library Functionalities and Demographic Profiles

Demographic Profiles	Chi-square test	Strength of Relationship
Gender	$\chi^2 = 11.026$, df = 4, p-value = 0.026*	Very weak**
Age	$\chi^2 = 80.858$, df = 20, p-value = 0.000*	Weak **
Ethnicity	$\chi^2 = 37.177$, df = 12, p-value = 0.000*	Very weak**
University	$\chi^2 = 18.377$, df = 12, p-value = 0.105	-

*Note: * $p < 0.10$, ** $p < 0.05$*

This study found that university is not a statistically significant indicator in terms of awareness of digital library functionalities. This suggests that there is no evidence of disparity among the four universities in terms of awareness of digital library functionalities that can benefit both the students and academicians in academic activities. Unlike the findings of Luan, Fung and Atan (2008), differences of such awareness exist between male and female respondents. But it is worth noting that the relationship is weak. Liu and Luo (2011) suggested the needs of providing targeted awareness of available digital resources to increase the usability of digital libraries. It was based on their study which highlighted the differences that exist between

undergraduate and graduate students due to their differing emphases and expectations for information from the digital libraries.

4.5.3.6 Awareness of the Importance of Digital Libraries for Education and Demographic Profiles

The following discussion focuses on awareness of the importance of digital libraries for academic reasons. This includes the benefits respondents may gain from using digital libraries. With respect to this, two questions were asked; one being “*I am aware that I can use digital library for my education/research information needs*” and the other one “*I am aware that my study/research group needs digital library more than other (scholar) search engines*”.

In earlier findings (section 4.5.3.5), it is discovered that gender, age and ethnicity are significant factors for awareness of digital libraries’ functionalities, but not the university. This section again attempts to investigate the above mentioned indicators’ relationships with demographic profiles. The results are provided in Table 4.31.

Table 4.31: Statistical Test Results for Relationship between Two Awareness Indicators of Digital Libraries and Demographic Profiles

Indicators	Demographic Profile	Chi-square test	Strength of Relationship
I am aware that I can use the digital library for my education/research information needs	Gender	$\chi^2 = 10.673$, df = 4, p-value = 0.030*	Very weak**
	Age	$\chi^2 = 80.182$, df = 20, p-value = 0.000*	Very weak**
	Race	$\chi^2 = 21.273$, df = 12, p-value = 0.047*	Very weak**
	University	$\chi^2 = 35.232$, df = 12, p-value = 0.00*	Very weak**
I am aware that my study/research group needs the digital library more than other (scholar) search engines	Gender	$\chi^2 = 6.895$, df = 4, p-value = 0.142	-
	Age	$\chi^2 = 0.011$, df = 20, p-value = 0.000*	Very weak**
	Race	$\chi^2 = 39.545$, df = 12, p-value = 0.000*	Very weak**
	University	$\chi^2 = 17.397$, df = 12, p-value = 0.137	-

Note: * $p < 0.10$, ** $p < 0.05$

Findings in Table 4.31 indicate that demographic profiles – gender, age, ethnicity and university are significant factors for digital library awareness in terms of the importance of such systems for academic information needs. Despite the dependency between the two variables, each of the relationship’s strength was measured as very weak. Inducing

the digital library awareness especially among new (or as well as to continuing students) is essential as emphasized by Liu and Luo (2011), where perceived usefulness (of the digital libraries) plays a critical role in the adoption of such new technology. They emphasized the importance of providing relevant courses to demonstrate the tangible benefits and value of using the services as well as promoting the use of digital library resources.

In contrast, only age and ethnicity were found to have a statistically significant relationship with digital library awareness in terms of fulfilling their study/research needs as compared to other scholar (search) engines. However, again the strength of the relationships is very low, as shown in the Table 4.31. From the view of physical library use, a study from Teoh and Tan (2011) indicated evidence of significant difference between ethnicity among Malaysian students.

In addressing the five research questions formulated in the study, the following sections (4.6 and 4.7) present the results of the path model that leads to uncovering and answering the research questions.

4.6. Estimation and Validation for Formative Model

Despite controversial and incomplete resolved issues concerning the conceptualisation, estimation and validation of formative indicators (Diamantopoulos, Riefler and Roth, 2008), Henseler, Ringle and Sinkovics (2009) provided a general structure for validity analysis for reflective and formative measures. It comprised two different sets of procedures for the: (1) evaluation of the measurement model, and (2) evaluation of the structural model. This study proposed a pure formative success model for digital libraries, using four formative dimensions as posited by Gable, Sedera and Chan. (2008).

Prior to answering the research questions addressed in this study, the estimations and validations of the formative DL Success model are presented. PLS path modelling for the formative measurement model is assessed statistically on two levels of analyses; at indicators level and at constructing (or structure) level. Alongside the results presented in the next sections, the answers to the five research questions would also be provided.

The appropriateness of using formative measures in empirical research such as this study is supported by suggestions and recommendations in the literature (Hulland, 1999; Diamantopoulos and Winklhofer, 2001; Jarvis, MacKenzie and Podsakoff, 2003; Diamantopoulos, Riefler and Roth, 2008; Henseler, Ringle and Sinkovics, 2009). If the measurement model is misspecified, it may lead to the misspecification of the structural model. Misspecification will lead to bias in the parameter estimates where this bias may affect the statistical significance (for further reading, refer to Jarvis, MacKenzie and Podsakoff, 2003; MacKenzie, Podsakoff and Jarvis, 2005).

Specifically, the formative measurement model developed for this study is a multidimensional construct of three formative first-order (only for one dimension), four formative second-order and one formative third-order. In this higher order formative model, error term exists at the level of individual dimensions (first-order and second-order) and at the overall construct level. Law, Wong and Mobley (1998: 741) indicated that “... *the dimension of multidimensional constructs can be conceptualised under an overall abstraction, and it is theoretically meaningful and parsimonious to use this overall abstraction as a representation of the dimensions*”.

The estimation and validation results of the developed DL Success model, using smartPLS (Ringle, Wende and Will, 2005) are as elucidated in the following sections.

4.7. Digital Library Success Model

Using covariance based methods such as Exploratory Factor Analysis (EFA), correlation and reliability are inappropriate for the purpose of validating formative model (Gable and Sedera, 2009). EFA is suitable for reflective model where the relationship assumes from construct to indicators (this implies effect indicators). On the other hand, cause indicators assume a relationship from indicators to the construct. As indicated by Anderson and Gerbing (1982) “...*proper specification of the measurement model is necessary before meaning can be assigned to the analysis of structural model*”. The proposed DL Success model was developed based on the three first-order formative model, four second-order formative model and one third-order formative model. Three first-order formative model is the digital library individual usage for information provisioning (DLUIP) dimensions of *Breadth of content*, *Depth of content* and *Dynamism of Interaction*. *Individual Usage Impact (IUI)* of the second-order model is hypothesised as being defined by formative indicators of DLUIP which is based on the theoretical framework by Ambrose, Rai and Ramaprasad (2006). Three other formative dimensions in the second-order are as recommended by Gable, Sedera and Chan (2008), which are *Institutional Impact (II)*, *Information Quality (IQ)* and *System Quality (SQ)*, while the highest level of the proposed model is the DL Success. As recommended by Gable, Sedera and Chan (2008), correlation analysis was done in order to examine the extent to which the indicators correlated with their respective global indicators (refer to section 4.4.5.8). The results indicated that of the 37 measures of the a-priori model, only 25 indicators were significant at the 0.001 level of significance where $r \geq 0.50$ were maintained. The next task was to estimate the DL Success model, based on the PLS path model.

4.7.1. Estimations of Partial Least Squares (PLS) Path Model

The formative measurement model is incorporated into the structural equation model (SEM) namely the PLS path model consisting of two main stages; first, the relationship between indicators and constructs (outer model) and second, between constructs (inner model). In the followings, all of the estimation results for the measurement model and structural models are discussed in detail, and referred to the smartPLS output.

Table 4.32: Overview of PLS quality criteria

Construct	AVE	Composite Reliability	R ²	Cronbach Alpha	Communality	Redundancy
BC	-	-	-	-	0.6261	-
DC	-	-	-	-	0.7125	-
ID	-	-	-	-	0.6758	-
DL Success	-	-	0.7386	-	0.5084	0.194
IQ	-	-	-	-	0.5898	-
IUI	-	-	0.7090	-	0.6263	0.377
II	-	-	-	-	0.4837	-
SQ	-	-	-	-	0.5106	-

Note: AVE - Average variance extracted, BC - Breadth of content, DC, Depth of content, ID - Interaction dynamism, DL - digital library, IUI - Individual usage impact, II - Institutional impact, IQ - Information quality, SQ - System quality.

Table 4.32 provides the summary of all the quality criteria in assessing the measurements and constructs of the partial least squares path model, as provided by smartPLS. The parameters of Average Variance Extracted (AVE), Composite reliability, Cronbach alpha, Communality and Redundancy were used in assessing the measurement model. Since this **study** applied a pure formative model, only the R² is applicable (cell with bold figures). The final model of the proposed DL Success model is as exhibited in Figure 4.6. The figure shows standardised PLS path coefficients model where the coefficients of the measures (outer weights) and constructs (inner weights) are as shown on top of the arrows. Detailed assessment results for study's formative measures and constructs are duly presented in the following figure.

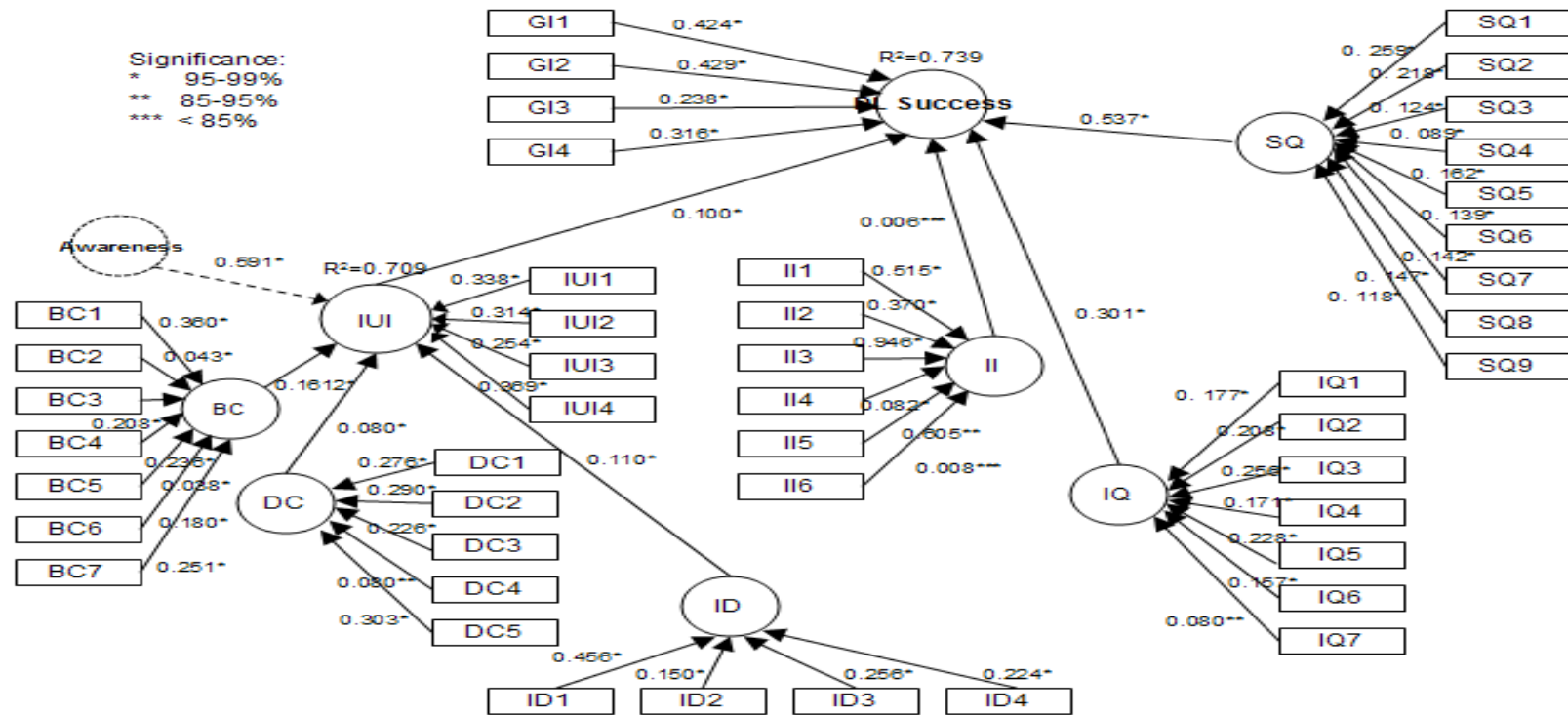

Figure 4.6: Partial least squares path model of relationships between indicators and constructs for the final model

Note:

- IUI-individual usage impact, BC-breadth of content, DC-depth of content, ID-interaction dynamism, II-institutional impact, IQ-information quality, SQ-system quality.
- All indicators of the respective dimensions are indicated as per dimension name for e.g. seven indicators of breadth of content dictated as BC[i], where $i=1,2,\dots,7$, five indicators for depth of content is DC[i] where $i=1,2,\dots,5$, and so forth. GI[i] is the global item of exogenous variable where $i=1,2,3,4$.
- Awareness factors are treated as the moderating effects of individual usage impact (IUI).

In Figure 4.6, the final proposed DL Success is presented. All the paths' coefficients (weights) for outer and inner models are significant at the 5% level. However, the weights for Institutional Impact (II) to DL Success are very low but significant at the 5% level of significance. The coefficient of determinations, R^2 , for both DL Success and Individual Usage Impact (IUI) are substantial at about 74% and 71%, respectively. Details of the results in validating the outer and inner models are discussed in the following sections.

4.7.2. Evaluation of the Measurement Model (Outer Model)

Evaluating the measurement model is actually evaluating the outer model. The formative construct validation of the study was performed following the guidelines given by Urbach and Ahlemann (2010), Henseler, Ringle and Sinkovics (2009), Diamantopoulos, Riefler and Roth (2008) and Diamantopoulos and Winklhofer (2001). Bollen (1989) and Bagozzi (1994), stressed that the concepts of reliability (i.e., internal consistency) and construct validity (i.e., convergent validity) are both **not** meaningful for the formative mode. However, two main assessments for the outer model are indicator validity and construct validity (Urbach and Ahlemann, 2010). As discussed in detail in Chapter Three, the results of the assessment procedures for the outer model (measurements) are as provided in the following table.

Table 4.33: Summary of Validation Outcomes of the Formative Measurement Model

Criteria	Fit indices	Results of Tested model	Remarks
Indicator weights	The indicator should be significant. Preferable coefficients of weights of 0.100 and greater (Lohmoeller, 1989; Wold, 1982) but cut-off lower limit was set as 0.05 (Pedhazur, 1997).	Based on the bootstrap results of smartPLS, the results showed all of the formative indicators are significant at 99% and 95% of confidence with some at 80%.	Met the requirements of indicator validity.
Variance inflation factor (VIF)	Acceptable values for VIF of indicators of the construct should be less than 10 (Cohen, 1988; Gefen, Straub and Boudreau, 2000) and a more rigid one, $VIF < 3.3 - 4.0$ (Diamantopoulos, Riefler and Roth 2008; Petter, Straub and Rai, 2007; Diamantopoulos and Siguaw, 2006).	The collinearity diagnostics procedure indicated that all of the VIF is below 3.0, the largest being 2.976.	Met the requirements (absence of multicollinearity).
Nomological validity	The construct behaves as expected and as sufficiently referred to in prior literature (Straub, Boudreau and Gefen, 2004; Henseler, Ringle and Sinkovics, 2009)	As suggested by Straub, Boudreau and Gefen (2004), in ensuring the content validity of formative construct, a thorough literature review should be performed. Hence, the nomological validity of the four constructs in the DL Success model is founded with theoretical considerations (as discussed in Chapter Three)	Established based on the theoretical considerations.

Table 4.33, continued

		where all of the postulated measures and constructs were conceptually justified and theoretically validated.	
Interconstruct correlations	Correlations between the formative and all other constructs in the model should be less than 0.71 (MacKenzie, Podsakoff and Jarvis, 2005).	Interconstruct correlations produced by the model were all below the stipulated value.	Met the requirements.

Jahner et al. (2008) indicated that indicator reliability refers to the importance of individual indicator of its related formative construct. From Table 4.33, the assessment consists of three main characteristics of indicator weights: significance, sign and magnitude. In the PLS path model, the estimation of weights was done via bootstrapping (Henseler, Ringle and Sinkovics, 2009; Tenenhaus et al., 2005; Chin, 1998b). Based on the bootstrap results of smartPLS, and cases = 959, samples = 959, the proposed DL Success model's weights were all significant at the 5% level of significance. In addition, the algebraic sign (all positive) was as theoretically hypothesised. However, varied results were gained in the magnitude of the weights where indicators of the Institutional Impact (II) dimension showed with a very low magnitude as compared to the other indicators. The values of VIF obtained were not raising the level of concerns on the multicollinearity problem in the sample data. Using all of the indicators, a multicollinearity test was carried out to determine the value of the Variance Inflation Factors (VIF). As discussed in the previous chapter, the cutoff value selected for this study is 4.0 (Petter, Straub and Rai, 2007). The indicators used in the

study would not be removed for a uni - dimensionality reason, instead VIF values were used to determine their redundancy problem. The VIF for all indicators is determined by using the *latent variable scores* from the smartPLS output, as suggested in the smartPLS's website online forum. The scores are regressed with their respective dependent variables (global items): Overall positive impact for individual (*GII*), Overall positive impact for university (*GI2s*), Overall satisfaction of Information quality is (*GI3*) and Overall satisfaction of System quality (*GI4*). All these four criterion measures were as postulated by Gable, Sedera and Chan (2008). Since smartPLS does not provide a test for collinearity, SPSS was used instead. All the scores produced by smartPLS were saved in a *comma separated values (CSV)* format and was used in the SPSS platform as input. The collinearity diagnostics procedure indicated that all of the VIF is below 3.0, the largest being 2.976. This is an indication of the absence of multicollinearity problems in the study data which shows that the construct reliability's requirements, as well as the indicator validity were met.

Diamantopoulos and Winklhofer (2001), and Straub, Boudreau and Gefen. (2004) indicated that content validity is concerned with whether the manifest indicators capture the entire scope of the construct, as per described by the construct domain. In this study, content validity of the formative constructs was based on nomological validity of the literature review related to the constructs' domain in the IS-Impact model introduced by Gable, Sedera and Chan (2008) and the IUIP model by Ambrose, Rai and Ramaprasad (2006). As suggested by Straub, Boudreau and Gefen (2004), a thorough literature review should be performed to ensure the content validity of the formative construct. Hence, the content validity of the five constructs in the DL Success model was found with theoretical considerations (as discussed in Chapter Three).

For the last guideline in assessing the formative measures, correlations between the measures and constructs were found to be below the fit index value, i.e., 0.71.

Overall, the assessment findings on the formative measures confirmed that the criteria of such measures had been fulfilled by the DL Success model.

4.7.3. DLUIP without and with Moderating Variable

The structural model or inner model is assessed via the examination of the path coefficients. Based on Henseler, Ringle and Sinkovics (2009), contradicting algebraic signs of paths that are against expectations are not considered to support the a priori formed hypotheses. The following two sections aim at elaborating the comparison and contrast between direct relationship model (or also known as main effects model) and indirect relationship (incorporating the moderating variable).

4.7.3.1 Individual Usage Impact Model without moderating variable

DLUIP model was first developed without moderating effects of awareness factors. Using the defined constructs based on Ambrose, Rai and Ramaprasad (2006), the predominant relationship is the paths from these constructs to IUI dimension.

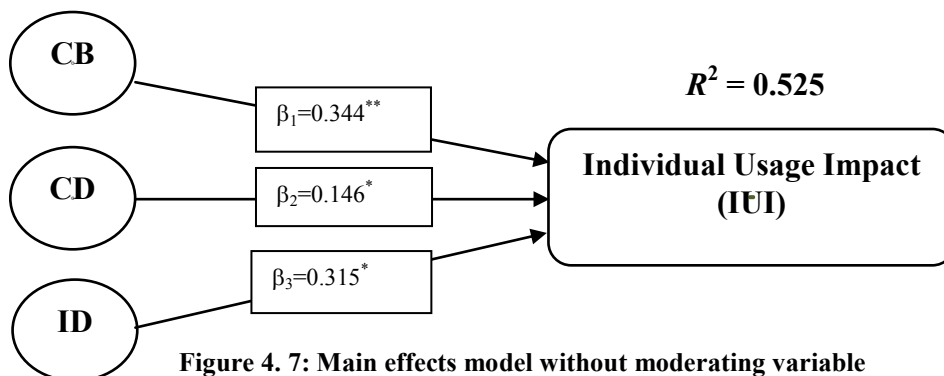

Figure 4. 7: Main effects model without moderating variable

Note: **p*-value < 0.05, ***p*-value < 0.20

In Figure 4.7.1, the three constructs account for about 53% ($R^2 = 0.525$) of the variation in the IUI. It also shows that all of the three path coefficients were significant at 95% level except CB (at 80%) providing evidence that the properties of DLUIP have

a positive influence on the IUI. The coefficients of CD (β_2) and ID (β_3) showed significant and positive relationships with IUI with 0.146 and 0.315, respectively. The CB coefficient, β_3 , posed a significant as well as positive magnitude but only at 80% significance level. Furthermore, the PLS model of the tested paths showed the evidence of predictive relevance with $Q^2 = 0.4367$. In smartPLS, the predictive relevance is calculated using Stone-Geisser's nonparametric test (Geisser 1975; Stone 1974) and employed using blindfolding approach (Chin 1998). The Q^2 value of this model suggests an index of the goodness of reconstruction by model and parameter estimations (Andreev et al. 2009) which measures to extent the model's prediction is successful (Urbach and Ahlemann 2010). The $Q^2 > 0$ of this model confirms the presence of predictive relevance (Razilan, Fatimah and Diljit, 2012b).

4.7.3.2 Individual Usage Impact Model with moderating variable

Helm, Eggert and Garnefeld (2009) recommended the importance of evaluating the indirect and direct relationships of the predecessor of a certain endogenous latent variable by performing the analysis of mediating and moderating effects (Henseler and Fassot, 2009). Additionally, as noted by Henseler, Ringle and Sinkovics (2009), researchers as well as practitioners using the PLS path model should begin by examining the direct effects and then, further analyse it with mediating analysis and moderation effects in order to learn more about the relationship between independent and dependent variables.

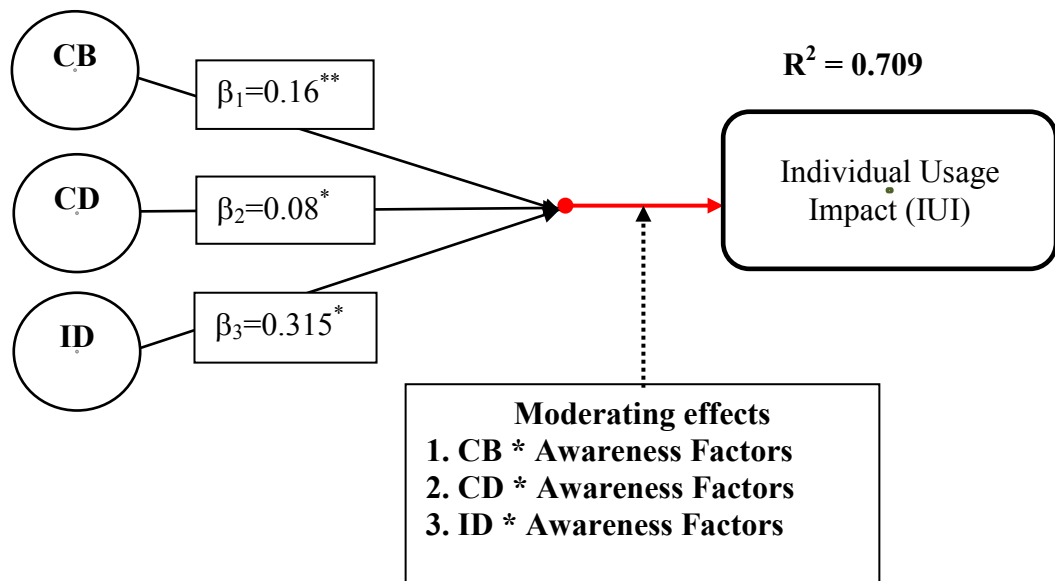

Figure 4.8: Moderating effects with moderating variable

*Note: * p-value < 0.05, ** p-value < 0.10*

The CB, CD and ID constructs' coefficients show positive impact to IUI and significant at the 5% level and 10% level (see Figure 4.7.2). Moreover the R^2 has increased to 0.709.

In summary, both main effects and moderating models show positive relationships between IUI dimensions and its constructs. However, the R^2 after the incorporation of moderating variable has shown an increment, which implies that the variation accounted in this model has increased about 18%. The model's interaction effect is 0.59 and the effect size, $f^2 = 0.2595$. f^2 is calculated as (Cohen, 1988; Henseler and Fassott, 2009):

$$f^2 = \frac{R^2_{with\ moderating} - R^2_{without\ moderating}}{R^2_{with\ moderating}}$$

$$= \frac{0.709 - 0.525}{0.709} = 0.2595$$

Moderating effects model using awareness factors show that these factors influence the strength of the moderated direct relationship (between IUI dimensions and its

constructs) linearly. In other words, in DLUIP model (having three independent variables and a moderator effect) the model's slope of the independent variable is no longer constant, but depends linearly on the level of the moderator variable. According to (Cohen 1988), such effect size represents between moderate and large effect (Cohen 1988). Due to this consideration, the DL Success model is generated using the moderating variable of awareness factors and the results is as elaborated in the following.

4.7.4. Evaluation of the Structural Model (Inner Model)

The structural model or inner model is assessed via the examination of the path coefficients. Based on Henseler, Ringle and Sinkovics (2009), contradicting algebraic signs of paths that are against expectations are not considered to support the a priori formed hypotheses. These results were produced using bootstrapping techniques (as PLS does not rely on any distributional assumptions). In addition, all indicators showed the algebraic signs as expected. As stressed by Henseler, Ringle and Sinkovics (2009), the structural paths whose signs in keeping with a priori postulated algebraic signs, provide a partial empirical validation of the theoretically assumed relationships between latent variables. Table 4.34 provides a summary of the validation outcomes for the structural model of the proposed DL Success model.

Table 4.34: Summary of Validation Outcomes of the Structural Model

Criteria	Fit Indices	Results of the Tested Model	Remarks
R^2	Approximation values of $R^2 = 0.670$ are considered substantial, 0.333 (moderate) and weak with 0.190 (Chin, 1998).	$R^2 = 0.739$ (DL Success construct) $R^2 = 0.709$ (IUI construct).	Met the requirements with substantial predictive strength.
Path coefficients	Analyses include the algebraic sign, magnitude and significance of the path coefficients (Albers, 2007).	All the paths coefficients were all of a confidence of 95% level but <i>II</i> construct was very small in magnitude but significant at only below the 85% confidence.	Met the requirements, based on Henseler, Ringle and Sinkovics. (2009) and Cenfetelli and Bassellier (2009).
f^2	Value of $f^2 = 0.350$ and above indicates large effect, 0.150 (medium) and low with 0.020 and below (Cohen, 1988; Chin, 1998).	<i>Not applicable for the study</i>	-
Q^2	Threshold value of $Q^2 > 0$ (Geisser, 1975; Stone, 1974; Chin, 1998b)	$Q^2 = 0.3465$ (DL Success construct) $Q^2 = 0.3275$ (IUI construct)	Met the requirements with evidence of predictive relevance.

Assessment of the capability (the degree) of the developed model on the level of explained variance is defined by R^2 . This is the central criterion in validating the structural formative model (Andreev et al., 2009). It is to measure the predictive strength of the latent construct, in which they are referred to as *DL Success* and *Individual Usage Impact (IUI)*. The values of R^2 can be between 0 and 1. Chin (1998b) defined 0.67 as *substantial*, 0.33 as *moderate* and 0.19 and *weak*. Referring to Table 4.34, the $R^2 = 0.739$ for DL Success indicates that almost three quarters of the digital library success can be explained by the model (original variability), leaving about a quarter which were not captured in the success model (residual variability). About 71%

($R^2 = 0.709$) of individual usage impact is explained by the three dimensions. Thus, incorporating moderating factors such as *Awareness* improved the IUI's coefficient of determination and increased the weights to 0.100. Both of the predictive strength (values of R^2) as shown by DL Success and Individual Usage Impact are considered substantial which implies that the model fits the study data well.

The final validation of the inner model is the predictive relevance via measuring the Q^2 statistic, using the blindfolding method. The results provided by smartPLS for calculating the Q^2 is as displayed in Table 4.35. Since the main objective of this study was to analyse the impact of all of the postulated indicators (independent variables) and not to separately test the indicators and/or the mediating effects, Q^2 statistic was found to be sufficient. This is the main reason why effect size, f^2 is not applicable in the study. The Q^2 value reflects the total impact or the overall effect size of the DL Success model which suggests the evidence of good predictive relevance (the shaded cells in Table 4.35).

Table 4.35: Blindfolding Results of the Predictive Relevance

Total	SSO	SSE	$Q^2 = 1 - SSE/SSO$
DL Success	3836	2506.76	0.3465
IUI	3836	2579.827	0.3275

Note: SSE-Sum of Squared Errors, SSO-Sum of Squared of Total

Both of the validation requirements for measurements and constructs have been fulfilled for the proposed DL Success model. Although very low weights (path coefficients for inner and outer models) for II construct were detected, the indicators postulated in the literature abided with all the fit indices' criteria in validating the formative model. Having presented the relevant research findings of the quantitative analysis, Table 4.36 presents the summary of the results obtained in addressing all the five research questions.

Table 4.36: Summary of the Results in Achieving the Study Objectives and Answering the Research Questions

Objectives	Research Questions	Results and Remarks
To determine the suitability of digital library usage for information provisioning (DLUIP) model in measuring the individual usage impact.	Is the usage for information provisioning model acceptable when applied in the context of digital libraries?	<p>About 50% (R^2) of the individual usage can be explained by the DLUIP model, which showed a moderate level of degree.</p> <ul style="list-style-type: none"> • The path coefficient of IUI \rightarrow DL Success was significant ($p < 0.05$) with algebraic sign (positive) and acceptable magnitude (0.100) as per hypothesized in the previous study. • It is an acceptable model.
To identify the users awareness effects in the moderating relationships between DLUIP indicators and individual usage.	Do the relationships between digital library usage for information provisioning (DLUIP) measures and individual usage depend on the users' awareness factors?	<p>Awareness factors incorporated as moderating factors in the IUI relationships with the three DLUIP dimensions had improved the R^2 of IUI from 50% to 71%.</p> <ul style="list-style-type: none"> • The results showed the significant ($p < 0.05$) influence of awareness on the individual usage of academic digital library (magnitude > 0.100). • Such relationships did depend on the users' awareness.
To investigate the most influential DLUIP dimension on the individual usage.	What is the DLUIP dimension that has the largest influence on individual usage?	<p>All of the DLUIP indicators and constructs were significant, some with 95% confidence and some with $< 95\%$, where the signs (positive) and magnitudes (> 0.100) fulfilled the formative model's criteria.</p> <ul style="list-style-type: none"> • Breadth of content (BC) was found to be the most influential indicator with the highest magnitude. • Indicators by using the DL system to meet users' information needs to have the largest impact on individual usage.

Table 4.36, continued

<p>To investigate the suitability of information systems success indicators in measuring the digital library success.</p>	<p>Is the DL Success model valid in measuring the success of academic digital libraries?</p>	<p>All of the DL Success indicators and constructs were between 95% and 99% of confidence except II (Institutional Impact).</p> <ul style="list-style-type: none"> • Two dimensions (system quality, information quality) were with large magnitude (SQ=0.537, IQ=0.301) and highly significant ($p < 0.01$). • Individual impact dimension was also highly significant ($p < 0.01$) with acceptable magnitude (0.100). • Institutional impact was significant with only <85% of confidence with magnitude below the fit index (0.006). • Based on the results, the key or largest impacts on the success of digital library were driven by the digital library's system quality and information quality indicators.
<p>To determine the impact of the four success dimensions on DL Success.</p>	<p>What is the degree of the impact of the four success dimensions on the DL success?</p>	<p>Using four formative dimensions, about 74% of the success can be explained by the study data.</p> <ul style="list-style-type: none"> • Based on Chin (1998), it is a substantial degree of ability of the model in explaining the data. • The key dimensions in measuring the success of digital library were system quality and information quality indicators. • The results indicated the four posited dimensions were capable of measuring the success of a digital library, however, the insufficiency of confidence was shown by the institutional impact dimension.

The following sections are devoted to discussing the findings from the interview sessions held with university librarians and library authorities.

4.8. Findings from the Interviews

Interviews were conducted to gain feedback from academic library authorities in regards to the universities' digital libraries. The interviews were accompanied with brief questions to extract the core points of Institutional Impact measures for academic digital libraries, from the library personnel's viewpoints. Using structured questions to suit the librarians and Information Technology (IT) officers of each university, this section presents the findings with regard to the library system; the online library resources; online collections; issues in migrating to the digital library; promotion strategy of digital library; and future plans. The information gained through these interviews as suggested in the study was to highlight part of the themes embedded in the premises of Institutional Impact dimension in the DL-Success model. Although it was found (from quantitative study) that the role of institutional impact dimension is not substantial in the success of academic digital libraries, this dimension constitutes important information in understanding the nature of academic libraries and digital libraries.

Data were actually gathered through a series of short interviews with 15 (fifteen) library staffs of the four participating universities. The main aim was to gain information on the varsity's library facilities in particular the online library resources; to support the empirical findings resulted from the quantitative analyses. The discussion began with the demographic profiles of the 15 respondents. The study sample was relatively small (as compared to the entire population of the university's library in Malaysia) and is not selected at random (lack of generalisability). However, this sample was considered to be representative of the four research universities' libraries, as Institutional Impact measures are treated as necessary measures as pointed out by Mohr

(1982) in the process theory. The selection of the sample is to support the need of having library staffs who possess deep knowledge and experience in the library (as well as academic digital libraries), and in system-wise. Thus, efforts were made to correspond not only with librarians but with the staff (and their superiors) who were engaged with and administered the system. The background of the interviewed staff is as explained in the subsequent section.

4.8.1. Demographic Profiles

The demographic information about the sample of interviewed library staffs is presented in Table 4.37.

Table 4.37: Demographic Information of the Library Personnel

Library personnel (Alias)	Gender	Current Position	Years of Working (in the current position)
R1	F	Head, IS Department	2
R2	F	Assistant IT Officer	2
R3	M	Librarian, IS Department	9
R4	M	Computer Technician	4
R5	M	Head, System & IT Division	2
R6	M	Computer Technician	3
R7	M	Librarian, IS Department	2
R8	M	Chief Librarian	5
R9	M	Head, System & IT Division	6
R10	M	Chief Librarian	3
R11	M	Deputy Chief Librarian	2
R12	F	IT Officer, Automation Dept.	8
R13	F	Librarian, Automation Dept.	2
R14	M	Head, Automation Dept.	2
R15	M	Deputy Chief Librarian	5

Table 4.37 shows the background of respondents including gender, current position and years of working experience in the current position. The interviews went smoothly as planned and the outcomes were as desired. All related information and data were gathered from each of the participant, ranging from the Chief Librarians to the technicians. Two staffs reported that they had worked in their current positions for more than five years, while the rest were five years and below. The top management were among the personnel who had worked for more than a decade in the library sector. The longest number of working years recorded was 33 years. The following table summarised the statistics of the 15 participants.

Table 4.38: Demographic Profiles of the Library Personnel

Demographic profiles	Categorical Measures	Frequency
Gender	Male	11
	Female	4
Position	Chief librarian	2
	Deputy Chief librarian	2
	Head of IS & IT Division/Automation Dept.	4
	Librarian	3
	IT Officer	1
	Assistant IT Officer	1
	Technician	2
Highest academic qualification	Diploma/Certificate	3
	Bachelor	5
	Master	7

Of the 15 respondents, the majority were male (about 70%) and the rest were female. Almost half of the respondents of the library staff were a master's degree holder, while others held either a Bachelor's degree or a diploma/certificate. In addition, technology-related positions (Information Systems and System Analyst) are as important as the librarian positions. These findings signify a higher requirement in librarianship skills to handle the diversity in library collections, services and facilities with respect to the fast growing emergence of the digital technologies. This is consistent

with the recent study by Choi and Rasmussen (2009). They concluded that the increasing use of digital technologies and resources of academic libraries, has witnessed the demand for library professionals with qualifications in digital technology, management and skills in communication.

Recruitment needs and requirements in fulfilling the transition process from the traditional library to the digital library may affect the scope of works and working environment of librarians. The Sultan Abdul Samad Library (USM) reported that currently there are four professional staffs and 10 non-professional staffs engaged with the digital library work functions. The results are provided in Table 4.39.

Table 4.39: Total Staff currently attached to the Digital Library by Job Scope*

University	Library	Personnel	
		Professionals	Nonprofessional
UM	University of Malaya Library	5	5
UKM	Tun Seri Lanang Library	2	6
UPM	Sultan Abdul Samad Library	4	5
USM	Hamzah Sendut Library	4	10

**Note: The figures shown are as of July 2010.*

4.8.2. Library Systems

Different library systems were reported in this study. Both UKM and UPM used Virtua windows-based system; both were contracting with the same vendor, VTLS Sdn. Bhd., while USM and UM library systems were operating via Ilmu Perdana and Symphony respectively. The setting up of the online library system for each university was recorded for UM in 2004 (in 1992 the services were fully computerized), UKM (1990), UPM (1987) and USM (1980).

4.8.3. Online Library Resources

The online library resources section gathers information on the online collections of e-journals, e-books and e-media. Each university library had reported large and different

total figures with respect to the above composition of electronic materials. Table 4.40 tabulates those figures; however, all the respondents' names were given aliases (to respect the confidentiality of the data given).

Table 4.40: Tabulation of Total Subscriptions of Online Collections of each University, as of July 2010

University	Total subscription of monographs (volumes)	Total subscription of e-journals (titles)	Total subscription of e-books (titles)	Total subscription of e-media (titles)	Total subscription of online full-text database (titles)
IPTA1	1,025,328	172,819	50,625	<i>Unsubscribe</i>	51
IPTA2	-*	24,000	418,663	<i>Unsubscribe</i>	87
IPTA3	587,494	700	25,000	<i>Unsubscribe</i>	40
IPTA4	1,127,672	1,657	141,963	217,630**	112

Note: * No response received due to uncertainty of the exact/estimated figures.

** The figures actually refer to microforms.

Results from Table 4.40 suggest more importance is given on e-book subscriptions in all university libraries except IPTA1. E-journals subscribed by IPTA1 library are as much as three times higher than e-books. This is the highest figure of the total e-journal titles as compared to the other three universities. IPTA2 shows a high preference for e-book subscriptions by having almost half a million titles. Although IPTA4 does not show a high total of e-journal subscriptions, its online full-text subscriptions superseded the other three, which implies that this institution gives more focus to full-text articles.

Figures displayed in Table 4.40 are not shown for comparative purpose, but rather to present variations of the number of subscriptions of online collections of the participating universities. The variations might be due to budget, university policy or directions. In terms of the total budget for libraries, the data collected through the interviewing sessions are as follows. Due to high confidentiality, the university's name is excluded as well. IPTA1 had received a static amount of budget (from the university)

for three consecutive years; 2008, 2009 and 2010 which in total was RM7.1 million. However, the actual budget spent varied; about RM10.06 million (2008), RM19 million (2009) and RM8.6 million (2010). Of the budget received, IPTA1 claimed that they had spent about RM6 million in the digital library.

IPTA2, on the other hand, was allocated RM14 million, RM15 million and RM11 million, in 2008, 2009 and 2010, respectively. According to the staff engaged with the systems and Information Technology, the budget allocated in 2010 was based on June 2010 and the library planned to apply for more in the future. In addition, for digital library management and other aspects, RM5.7 million, RM4.7 million and RM1.6 million had been spent in 2008, 2009 and 2010, respectively. Most of the budget spent was allocated for subscriptions of databases and renewal of subscriptions for the following year.

For both IPTA3 and IPTA4, there was not much information and data obtained from the relevant personnel involved in the interview session. IPTA3 received a total library budget of only RM4.1 million in each of the three years. Only about RM34,000 had been allocated for the digital library in the year 2008, RM2.96 million (2009) and only RM113,000 in 2010 (June). As for the IPTA4 library, a considerably higher budget had been allocated for the past three years, amounting to RM21,038,400 (2008), RM20,710,400 (2009) and RM19,710,400 (2010). The respective personnel had not provided specific information on the allocation for the digital library.

IPTA3 showed to be the lowest recipient of the library budget. No elaborations were given during the interviews; however, the budget spent for the digital library had been mainly allocated for the expenditure of the new server, as well as for maintenance purposes. The low amount of budget received by IPTA3 is consistent with the volume of subscriptions exhibited in Table 4.41. IPTA3 showed the least total of subscriptions for each category.

Discussions conducted among the 15 respondents uncovered several issues that emerged from the migration of the traditional library to the digital library. The findings from the short interviews are organised and discussed in accordance to the following themes that emerged from the respondents' answers.

4.8.4. Transforming to Digital Libraries

Transforming from traditional libraries to digital libraries may not be as impressive as it looks. Despite the demand for library resources and services in digital formats, budget and staff allocation may pose new challenges in managing the digital library in academia. According to Choi and Rasmussen (2009), as referred to Grabe and Sturges (2005) and Tennant (1998a, 1998b); staff allocation and hiring of new skilled personnel is one of the challenges that (academic) libraries are facing. New skills mainly related to digital technologies required may impose new job settings of delivering and providing online library resources and services in digital formats. In view of such new perspectives in an academic library environment, the following sections present some discussions pertaining to issues and aspects that were extracted through the interviews with library personnel of the four participating research universities.

4.8.4.1 Staff Requirement

Of the 15 respondents, 10 of them raised their concerns on the issue of staff requirements. Managing a digital library involves more than just managing the existing staff. One of the respondents (known as R1) claimed that the work nature is not the same as before, where they (librarians) need to educate users (students and academic staff) and to promote the use of the university's digital library. This was supported by R4 where he admitted that managing a digital library had resulted in the increase in tasks especially in managing the subscribed journals, and this requires more trained staff

members (whether to employ new staff with the required skills and qualifications or to train the existing staff). R8 expressed his frustration with the problem of existing staff who end up doing multitasking jobs. Another respondent, R5 was also worried about multitasking jobs for managing, cataloguing and monitoring both the digital and printed materials, and insisted on employing new personnel, as he said: “*digital library melanggan tapi local content buat sendiri, justeru bertambah kerja staf untuk monitor subscribed journal, printed journal, online pun kena monitor...kena ada additional staf untuk pantau journal, pantau network*” [translation: digital library is subscribing but create their own local contents, thus increasing the workload for staff to monitor the subscribed journals, printed journals, even the online-based needs to be monitored...must have additional staff for monitoring journals, monitoring the network]. The development of local contents is commonly created by the university library; thus this may require additional staffing to engage with the management of the digital library.

Another concern was raised by R15 who said: “*Staf akan dipindahkan ke tempat lain sebab digital library need more staff for indexing, etc.*” [Staff will be transferred to another place because the digital library needs more staff for indexing, etc.].

The above paragraphs present some of the accounts recorded in the discussion that claimed that the digital library is not reducing the staff requirement. Despite requiring new skills, new personnel are needed to cover the increased tasks related to digital libraries. Past studies (Chowdhury and Chowdhury, 2003; Sreenivasulu, 2001) have suggested that in order to gain effectiveness in managing the emerging digital library, competencies and skill sets are required. Thus using the existing staff may be impractical in the process of digital library transition or management.

4.8.4.2 Overall Costs

Transforming from a printed to a digital environment library requires not only manpower and new skills, but also long term investment. The costs may not be as high as it is in the business world, but a higher figure should be spent on the hardware and software for deploying a digital library. Nine out of the 15 participants claimed the overall costs spent on managing digital library may not be low, but its implementation is convenient and at the same time, it is capable of reducing other costs. On one hand, it results in less expenditure, incurred in buying fewer printed books or journals or for ordering new materials, and less maintenance of physical space and book shelves. But, on the other hand, server (or other hardware) maintenance is always high, as well as other maintenance costs like software, contracts and the subscription fees. R7 raised the issue of overlapping subscriptions of the digital contents which caused the online contents to be more expensive.

4.8.4.3 Allocation of Budget Received

Budget allocated (by the university) to the library, as well as the digital library, is practiced by all universities. This was asserted by R10, the Chief Librarian of IPTA4. The library personnel admitted that the budget received was very helpful especially in managing the digital library. R5 mentioned that overspending of budget sometimes occurred because of the high maintenance of databases. The budget spent was mostly on networking and systems besides the annual increases of subscription fees. R1 stated that the library had to bear the additional costs incurred. R3 stated that the economic downturn and fluctuation of currency were among the factors that affected the overall costs spent on the digital library, while R9 and R15 pointed out reasons such as the library not generating enough revenues and lack of sponsorships, had made the library very dependable on the university budget.

4.8.4.4 Promotion of Digital Libraries

Based on the responses extracted from the interviews, the researcher identified two main types of promotions to the advancement of the use of the digital library among the academic community. The most applied promotion used was by conducting information skills classes to students which included conducting special classes or training to new students. R8 mentioned that their classes were arranged by either their vendor or by the library. The second most viable way of promoting the digital library is via the social network, *Facebook*. All of the four universities share their digital library news and stories on *Facebook*. Their followers can make their queries, suggestions, and so forth on this social network, which makes it a more convenient platform to share the latest news and information related to the digital libraries. Other techniques of promotion are through email broadcasting, road shows and conducting events such as “A Day with the Customers.”

4.8.4.5 Expectations of the Digital Library Usage

In managing the information and knowledge acquisition procedure, expectations towards the digital library usage could be phenomenal. All of the participants responded with “increasing drastically” to the question, except for two, R1 and R15. R1 claimed that the increment occurred gradually instead of drastically. Whilst R15 claimed that the speed in the increase depended on the period in the semester, for example, during the examination period, usage is exceptionally high as compared to the beginning of the semester. The statement was supported by the usage statistics provided by the system’s software. It was also earlier agreed by R7 who claimed that there was a mixed pattern of usage so far. In a more controversial manner, R5 suspected the vendors for the manipulation of usage statistics to intentionally raise the renewal costs. This might not be the central issue of the topic but it was highlighted during the interview sessions to

the libraries. Overall, even though the usage statistics may not increase exponentially, in the long run, most of the participants believed that the digital library has the ability to lead to exceptional usage among academic users.

4.8.4.6 Digital Libraries in Positioning Research University

As reported in the *STAR* newspaper, dated 24 July 2011, the designation of research universities (RU) for UM, UKM, USM, and UPM was according to the 9th Malaysia Plan. The most prominent benefit of being one of the RUs in Malaysia is that each of the RU is entitled to receive an additional RM100 million in research grants, as well as for postgraduate scholarships (Lim, 2011). As part and parcel in heading and maintaining the designation, digital libraries become a crucial platform for academic knowledge outreach. The discussion included the role of digital libraries in elevating the university ranking and the better positioning of the RU status. Indeed, none of the participants refuted this statement. Instead, they stressed that the RU ranking was based on the publication collections, updated journals, and the staff publications in ISI or Scopus journals. These were among the requirements that need to be fulfilled in order to achieve the title of RU. R3 believed the role of the digital library was vital in providing high quality information to the academic community in a quick and timely manner. Besides that, R8 pointed out the fundamental role of the digital libraries was the convenience of using such contemporary technology, for education and research, which did not require its users to be at the university library, but may be anywhere in this part of the world as long as he or she is connected to the Internet. R5 and R6 admitted that the digital library owed so much to the current technology in IT and ICT, while R9, R10 and R11 agreed that the digital library helped to upgrade the university's standard. Overall, the digital library plays an important role in moulding the status of the university in the RU rankings.

4.8.5. Current Implementation and Future Plans for Digital Libraries

The interviews conducted were concluded with questions related to the current activities and future plans for the digital library, along with the obstacles faced in its implementation.

4.8.5.1 Collaboration Projects

Collaborating libraries with other universities was achieved by a consortium project named PERPUN. PERPUN is a forum of cooperation among all the Heads of University Libraries and the Director General of the National Library of Malaysia. The establishment of an electronic library network among the university libraries, current information services, subscriptions of databases and publication delivery services among Malaysian Academic Libraries form some of the focal discussions in quarterly forums. PERPUN committee members include the Chief Librarians of all respective academic libraries involved, and also the Director General of the National Library of Malaysia. In 2006, the portal for PERPUN (<http://portal.perpun.net.my>) was officially named as *MyUnitNet* (Malaysian University Libraries & National Library Network) where the selection of the name was based on a naming competition. According to R1, the subscription of journals was based on the consortium (PERPUN) so that they could be entitled to cheaper prices. Through the PERPUN consortium, all of the universities are connected to MyUnitNet, MyUlis (Malaysian Union List of Serials), MyURC (Malaysian University Repository Collection) and MyTO (Malaysian Theses Online). All of these databases are among the services and functionalities of PERPUN that were developed in making the portal as a one-stop centre for information searching and information sharing among academic users.

As part of the agreement, academic online library resources shared among consortium members would portray the mutual aid in keeping the pace of technology of the digital library amidst the academic libraries throughout this country.

4.8.5.2 Future Plans

In driving the strategic plans for the deployment of the digital library, two main themes were discovered through the interviews which encompassed the digital library system and access network, and resources and services. The first was the plans related to the aspect of system and technology. The second was the plans on the additional resources and services to be provided especially in collaboration with other varsities.

The current system and technology imposed concerns to most of the participating academic libraries. R2 admitted that the library needed to be equipped with a high-end server to support many different databases. In addition, R3 suggested the exploration of new and current technology that is capable of enhancing digital library services and functionalities. The network technology particularly subscribed by the institution, needs improvement to avoid congestion, as well as expansion (for e.g., WiFi for more areas in the university), based on comments received from users who found it difficult to access particular resources via online library resources. R5 mentioned that in managing the digital library, there should be efficient technical support for a problem-free implementation. Thus the main future plans included improving and expanding network facilities (like expanding WiFi coverage), digitising all library resources as well as a strategy for remote network connection (remote access especially from home).

The second future plan addressed the scope of more resources and services, as well as collaboration with other varsities with respect to online library resources. R4 and R15 emphasised the development of local contents in the near future, to improve

the university's own resources and services towards becoming content providers. R6, R7 and R10 said the plan should include more collaborative efforts among universities so that all the digital libraries could communicate with each other. The main aim of the collaboration is to create integration of the digital library system so that an efficient inter-library loan service can be realised in the future. In this fashion, a one-stop search gateway can be gained besides the possibility of making inter-library loans for institutional repositories. R9 commented that apart from projecting the plan for creating inter-library loans, digital library systems must at first be standardised. From another perspective, R12 and R14 both agreed on providing 24-hour library services in the future. The ambitious plan could foster the idea of creating the online library resources as a one-stop search centre.

Through the questions, the viewpoints obtained from the participants centred on the plans for the existing online library resources. In the course of the answers given, the basic assumption of these two main themes is that they are the core elements for solidifying the implementation of the digital library in academia.

4.8.5.3 Major Challenges in Implementing the Digital Libraries

Despite the accomplishment of providing online library resources to the academic community, the current implementation of such services is challenged by several obstacles. Three main problems were revealed throughout the interviews. Firstly, the financial aspect for which increased access to information resources would lead to shifting more budget each year; ranging from subscription fees, staffing, to network facilities. Participants R1, R3, R4, R8, R9, R10, R11 and R14 were among the eight personnel who pointed out that the digital library required a high budget.

The second problem is on manpower and skills. R4 and R9 expressed their concerns on the dependability on vendors. Librarians and technicians still lack the

know-how of digital libraries. R4 highlighted the issue of the librarians' limited knowledge especially in IT areas, in carrying out the digital library job function, and this is posed a big challenge to the academic library he is attached to. R9 drew the attention again to the reliance on vendors, which is due to the staff's limited technical knowledge of the digital library technology. The discussion revealed that the mitigation of such challenges would lead to the first challenge, that is, budget to educate and train the staff.

Thirdly, the increasing pattern of the digital library usage has brought big immense challenges to librarians, as well as IT officers, in manoeuvring the digital library services. R10 considered the online system and hardware being the two focal axes in bringing the system up and running. R15 raised his concern about the lack of technology and research on the technical aspects of digital libraries, that could further challenge librarians, as well as technicians.

The three major challenges highlighted by the participants through the interviews indicated that in spite of the merits of bringing the technology to the academic world, facing and mitigating such challenges has become part and parcel of the librarians' responsibilities.

4.9. Concluding Remarks on the Interview Outcomes

The outcomes of the interviews might have shed light on why such insufficiencies of significance for the Institutional Impact (II) dimension were achieved in the DL-Success model. The DL-Success model showed that this dimension may be regarded as the least important (least influential) in explaining the success of academic digital libraries. The magnitude of the relationships $II \rightarrow DL \text{ Success}$ was very low (0.006) which was far below the fit index. It was also noted that the path of $IUI \rightarrow DL \text{ Success}$ was low as well with a magnitude of 0.100, but it was still an acceptable index using the cutoff

limit of 0.05 (Pedhazur, 1997). However, both were significant but the Institutional Impact dimension has a very low confidence level. From the analysis of the librarians and library staff's perspectives through the interviews, such results were probably achieved due to these reasons:

1. The nature of the academic digital library of public universities which is not a business provider showed that the Institutional Impact measures may not have a direct counterpart with other business entities. Therefore, this dimension may be less crucial, as compared to the other three dimensions, in measuring the success of the academic digital library. In contrast, the organisational impact dimension used in measuring the success of Enterprise Systems (ES) in the IS-Impact model (among business organisations) is of high importance due to the fact that business entities are competing with each other and organisations have a direct counterpart, such as the e-commerce or e-business. Therefore, such measures will give a direct impact on the success of business, as well as to the ES itself.
2. The Institutional Impact measures like staff requirements, overall costs of the library, budget received, the digital library usage and positioning towards RU rankings may not be important in the sense of giving a direct impact on the performance of the academic digital library. The academic digital library is not run by a body that aims at supporting business needs but more towards providing and supporting intellectual requirements. This is a major departure from the definition of organisational dimension that was conceptualised and operationalised in the IS-Impact model introduced by Gable, Sedera and Chan (2008). However, the dimension is still relevant in measuring the success of academic digital libraries in this study because digital libraries are controlled,

managed and maintained by the institutions. Therefore, in order to realise the digital library process in an institution, the institutional's measures should be included in measuring the success of the system. In addition, in the DL Success model, it was statistically significant, however with a low confidence level. As stated by Cenfetelli and Bassellier (2009: 701), "*very few reasons, if any, would lead to the decision to remove an item after a single study showing some concerns in the results, when the theoretical definition of the construct justifies its inclusion*". In addition, according to process theories, Mohr (1982) emphasised on the event where the independent variable might be assumed to be insufficient to "cause" the dependent variable (outcome), but it is held to be necessary for the outcome to occur. In the case of the academic digital libraries, the Institutional Impact dimension might not have a direct impact on the digital library success but its measures were considered and taken into account.

3. Each individual (respondent) using the academic DL is to represent him/herself as compared to the organisation representing the company he/she is attached to. These are two different situations where the relevance of such impacts on individual needs might differ. As argued by Wang and Benbasat (2005) humans attribute human characteristics to technical artefacts. Thus, with different intentions and aims of usage, the level of Individual Impact in influencing the success of the digital library might be different. The respondents selected in answering the measures for Institutional Impact was only among the academic and library staffs. Students were excluded as they are considered as individual users only and not directly attached to a university.

4. Each of the RU is under the umbrella of the same body, i.e., the Ministry of Higher Education (MOHE). With respect to the budget allocation, it is under a controlled budget where each university receives about the same amount each year from MOHE. If there is any additional budget required, the variations of total budget among the universities are still found to be small. This scenario has made the Institutional Impact measure become a fixed factor among universities as competition for getting or spending a higher budget is not the main concern, for as long as all of the academic digital libraries are under the same authority, the digital library is there to offer its services and operating as desired.

5. The interviews also revealed additional insights into the weak influence of Institutional Impact measures on the DL Success. Librarians and library staffs engaged with the digital libraries might also engage with the traditional library tasks. Despite the lack of competent skills in digital library technology reported in the interview sessions, staff requirement factor might not be of high priority, as libraries are using the existing staff to fulfil this job requirement. Such a situation convenes the needs for training to equip librarians with related digital library skills; nonetheless, the digital libraries are still up and running as expected. Underlying this concern, the circumstances are very much alike in the four participating universities. Regardless of the number of staffs required for managing and operating the university's digital library, and regardless of the insufficient skills required to run the system, the academic digital libraries are still available and manageable. The results may indicate that staff requirement measures might not have a direct influence on the success of digital libraries.

All of the reasons given are based on the outcomes of the interviews that may support why institutional and individual impacts have less impact in the success of the digital library but yet necessary to be considered in the digital library process. Moreover, the IS-Impact model has never been used in IS evaluation in different IS applications such as the academic digital libraries. Thus, further studies need to be done in testing whether the dimensions and measures should remain across different IS applications (which is beyond the scope of this study).

4.10. Improvements in Digital Libraries

The final open-ended question required opinions on the main improvement that respondents expected of their digital libraries. In providing a summary of this feedback, more than half of the respondents talked about improving the information quality of their academic digital libraries. The main issue rendered was on the insufficiency of resources, lack of the latest and high impact journals, and the site not being regularly updated. More e-books are required besides improving the list of e-journals to include broader research areas. In addition, the number of full-text downloaded journals needs to be increased. Apart from that, searching techniques was also raised as respondents claimed that they sometimes faced difficulties in locating certain articles.

Furthermore, issues relating to the system and network facilities were also brought up. About half of the respondents mentioned that the system needed to be upgraded in terms of its design, server and at some point, the respondents even commented on the digital library's use of dull colours. The respondents asked for higher speed and excellent WiFi connections in the university areas, so that they could access and download articles from the digital library easily. More than a quarter of the responses gathered were on the improvement of the network bandwidth, where

comments centred on the frequent network congestion which hindered the efficiency in using the digital library.

Other issues were designing the digital library to be more user-friendly, simple to use and having more languages other than Bahasa Melayu and English.

4.11. Summary

Detailed descriptive analyses, preliminary findings and results of model estimation for the study were presented in this chapter. This study also uncovered key aspects of the research ranging from the users' backgrounds and the measurements used to evaluate the success of the digital library via the application of the Information System success model, namely the IS-Impact model which had been extended by introducing the individual usage impact based on the digital library information for provisioning construct. Razilan et al. (2009a) emphasized that it is worth to understand that the digital libraries are not only offering an online environment, but more towards information resources, learning support and information literacy services which are accomplished through human-computer-interaction (HCI). Usage benefits of the digital libraries encompass more than what the technology is offering to academic users as they entail their academic needs as well.

The DL Success model proposed in the study suggests that all the posited constructs used in the study were significant in explaining the study data. While almost three quarters of the success was able to be explained by the model, only about one quarter was not captured in the defined success measures. This shows a substantial explanation of the success of academic DL was gained through the proposed study model. Moreover the findings provide useful information in regards to the observed circumstances (the impact on individual usage on the digital library) an awareness

intervention has a greater effect on the individual impact (Razilan, Fatimah and Diljit, 2012b).

The short interviews that encompassed brief discussions with the library personnel of the academic libraries indicated that the implementation of the academic digital library was well accepted by the academic users. A drastic increase of digital library usage from time to time detected through the system logs testified the high demand of using online library resources for academic purposes. Notwithstanding the merits and convenience brought by the digital library for many, librarians faced different challenges in making the system up and running. The overarching challenge encircled on financial, information resources and technologies to better support the institutional digital library to operate and serve as expected.

In the following chapter, the conclusion of the study is presented. The discussions include a summary of the research findings, answers to the research questions, research and practical implications, contributions and finally suggestions for future works.