

CHAPTER 3

EXPERIMENTAL TECHNIQUES

3.1 Introduction:

This chapter describes the experimental details and equipments used for preparing and characterizing the multilayer CdSe thin films starting from the preparation process using physical vapour deposition method. To identify the crystal structure of the deposited films and to estimate their average grain size, experimental techniques viz., x-ray diffraction (XRD), scanning electron microscopy (SEM) and Energy Dispersive X-ray Analysis (EDX) were used. Optical characterization of the films was carried out using UV-VIS-NIR transmission spectroscopy and the film thickness was determined using the Tolansky technique.

3.2 Dual source evaporation system for physical vapour deposition method:

Multi-layer CdSe thin films has been prepared using physical vapour deposition method employing a home built dual source vacuum evaporator. This system consists of a vacuum pump unit together with a vacuum chamber and an electrical unit, which supplies high current to the source evaporator. The schematic diagram of the vacuum evaporator is shown in Figure 3.1

The vacuum pump unit consists of a rotary pump and a vapour diffusion pump. The pumping operation starts after switching on the rotary pump by closing all the valves. The roughing valve is opened to bring down the pressure

of the chamber to about 10^{-3} torr followed by turning on water for cooling diffusion pump. Then the diffusion pump is switched on, to lower the pressure to 10^{-5} torr.

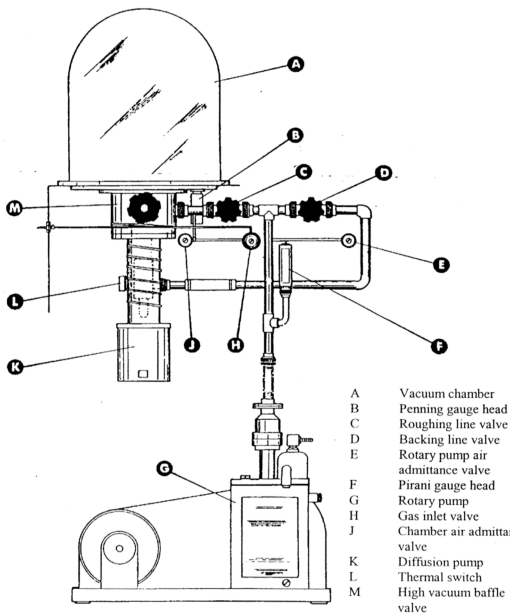

Figure 3.1: The schematic diagram of the vacuum evaporator

The vacuum chamber is essentially a glass cylinder resting on a metal base with a thick metal cover at the top, which holds a substrate holder and a manual source shutter assembly. The chamber is also provided with a "thickness and rate monitor" (STM 100) having a 6 MHz sensor crystal, which gives information for controlling the rate of evaporation and monitoring the thickness of the films during deposition. For the production of multilayer films two evaporation sources are provided inside the chamber, which can be operated in succession.

The electrical unit consists of two step-down transformers connected to a.c mains. This unit supplies a high current to a maximum of 60 A and directly heats the metal crucible called the boat. The temperature of the substrate holder is measured using a digital thermometer.

3.3 Sample preparation:

Microscope glass slides of thickness approximately 1-1.2 mm are used as substrates. The slides are cut into a rectangular shape of dimension $2.5 \times 2.0 \text{ cm}^2$. The substrates are cleaned to ensure that they are free from contamination as explained below. Firstly the substrates are cleaned in a detergent solution, which is followed by a thorough rinse in distilled water. Then they are ultrasonically cleaned in distilled water for a duration of about 20 minutes and immersed in acetone to remove grease or oil on the surface of the slides. The substrates are then rinsed in distilled water and dried in an oven at a temperature of about 50°C . An aluminium mask with six rectangular holes of each having dimensions $2.0 \times 1.5 \text{ cm}^2$ acts as a holder for the glass substrates during the deposition of the samples.

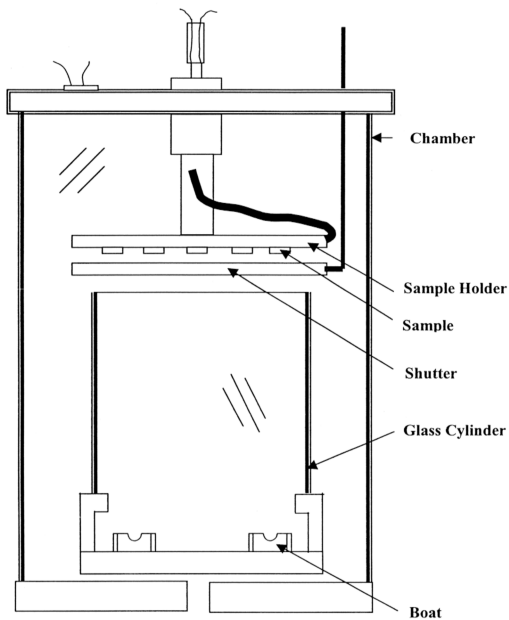

Figure 3.2: Schematic diagram of the vacuum chamber

The chamber is properly cleaned and dried prior to each preparation to avoid contamination and to achieve high vacuum. Preparation of all samples is

carried out when chamber pressure is about 10^{-4} torr. Selenium (pellets) and Cadmium procured from 'Aldrich Chemicals' (99.999% pure) are placed on separate Molybdenum boats. Cadmium is heated by passing an optimum current of 38 to 40 A and deposition rate is from 0.1 to 6 Å/s. Selenium having a lesser melting point is evaporated by passing a lesser current of 30 to 32 A and the deposition rate is from 0.1 to 4 Å /s. Current more than the optimum current range mentioned above, leads to improper deposition. The reason for this could be due to scattering of the evaporated atoms in all directions with little deposition on the substrate. Alternate layers of Cadmium and Selenium are deposited on unheated substrate by heating successively the two sources containing Cadmium and Selenium. CdSe multi-layer films have five layers and the topmost layer is Cadmium since it is less volatile than Selenium. The thickness of the films varies from 600 to 3500 Å and thickness of each layer varies from 100 to 500 Å and seven sets of samples each set having six samples has been prepared for the present work.

3.4 X-ray diffraction:

In the present work a Siemens D 5000 Diffractometer (X-ray Diffractometer: *Operation manual*) with $Cu-K_{\alpha}$ radiation ($\lambda_{\alpha} = 1.54056 \text{ \AA}$) is used in taking the x-ray diffraction spectra of all the samples. The samples are scanned in the 2θ range of 10° to 80° . The diffractometer consists of a goniometer, the x-ray tube, the tube stand, the diaphragm system required for the measurement and the sample changer. The radiation emanating from the line of focus of x-ray tube is diffracted at the sample and recorded by a detector made of a high sensitive scintillation counter. The sample rotates at a constant angular velocity such that the angle of incidence of the primary beam changes while the

detector rotates at double angular velocity around the sample. The diffraction angle (2θ) is always equal to twice the glancing angle (θ). The diffractometer beam path is shown in Figure 3.3. Each time the Bragg condition is satisfied, the primary beam is reflected from the sample to the detector. The detector connected to a measuring electronics unit measures the intensity of the reflected radiation and angular position of the reflection is displayed at the display unit. For clearer representation, the K_{β} reflections may be suppressed using a monochromator.

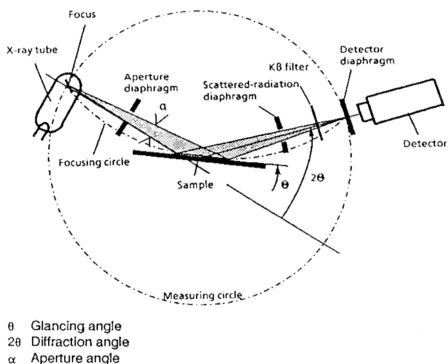

Figure 3.3: Diffractometer beam path in $\theta/2\theta$ mode
 (X-ray diffractometer: Operation manual)

The measurement programs can be set up automatically to perform background subtraction, peak search, data smoothing, profile fitting, qualitative or quantitative phase analysis after each measurement. These data are used in order to determine the crystallinity and to estimate the structure parameters such as the lattice constants and the grain size of the clusters in the samples.

3.5 SEM and EDX:

SEM produces a magnified picture, which depicts the features of the surface of film as a realistic three-dimensional image. Morphological studies of the samples are carried out using an Oxford LEICA S440 Scanning Electron Microscope (SEM: *Operation manual*). In SEM, the surface of the specimen to be examined is scanned with an electron beam and the reflected beam of electrons is collected and displayed at the same scanning rate on a cathode ray tube. The electron beam impinging on the specimen gives rise to a number of useful signals. One among them is the secondary electrons emitted from the surface of film, which gives insight into the surface topography of the specimen. The next is the x-rays coming out from the samples, which are characteristic of the atomic type and this can be used to quantify the atomic composition of the sample. The schematic diagram of scanning electron microscope is shown in Figure 3.4.

Energy dispersive x-ray analyzer (EDX) attached with SEM is used for the quantitative compositional analysis of the samples. All these signals are monitored simultaneously, stored and analyzed digitally. The microscope has a resolution of 3nm at 40kV with a LaB6 filament. The software in the

microscope's computer controlled many of the microscope's functions. SEM operating voltage is in the range of 2 to 10 kV.

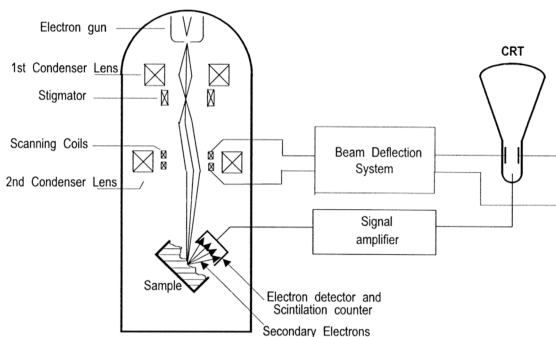

Figure 3.4: Schematic diagram of scanning electron microscope
(Manfred 1980)

3.6 Image processor:

A LEICA Q600 (Image processor: *Operating manual*) image processing and analysis system has been used to find the grain size of the samples as depicted through the SEM pictures. The processing of the data in the image is controlled by a compatible personal computer processor. 'Quantimet', an interactive software is used for the primary access to the

system's functions. Measurements are grouped according to the type of images and in each case the binary image provided a mask for the underlying grey image. The results of measurements are displayed as tables and histograms.

3.7 Tolansky technique:

Thickness measurements are taken using Tolansky method (Chopra 1969) and the experimental set up is shown in Figure 3.5(a). With a monochromatic light source such as sodium lamp, the multiple reflected beams between the upper glass slide and the substrate form interference fringes that are evenly spaced.

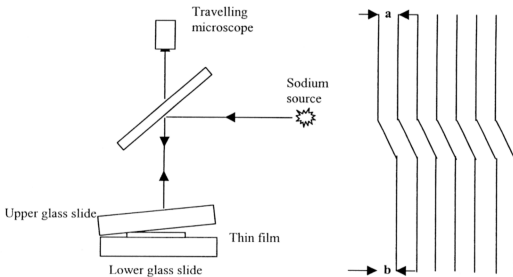

Figure 3.5: (a) Schematic diagram of Tolansky technique and (b) fringes as observed in the travelling microscope.

However the presence of the thin film edges changes the optical path of these beams. As such a step-like shift in the interference fringes is observed as shown in Figure 3.5 (b). Both the distance between fringes a and fringe shift b can be measured by a traveling microscope. The thickness d is then calculated using the following equation.

$$d = \frac{\lambda}{2} \left(\frac{b}{a} \right) \quad \text{-----(3.1)}$$

where λ is the wavelength of the sodium lamp (5890 Å)

3.8 Transmission spectroscopy:

The transmission of the films has been studied using a Jasco V-570 UV/VIS/NIR Spectrophotometer (UV/VIS/ NIR Spectrophotometer: *Operation manual*) in the range of 200 to 2500 nm. Figure 3.6 shows the optical system of Jasco V-570.

A deuterium discharge tube is used in the ultraviolet region (190 to 350 nm) and tungsten iodine lamp is used in the VIS/NIR region (340 to 2500 nm) as light sources. The light from the light source is converged and enters the monochromator. The light is split into two light paths by a sector mirror, one incident on the sample to be measured and the other on the reference glass plate. This light that is incident on the photomultiplier tube or PbS photo-conductive cell is converted into an electrical signal. This signal is synchronously rectified, converted into digital form and entered the microcomputer. The signal processed by the microcomputer is displayed on the

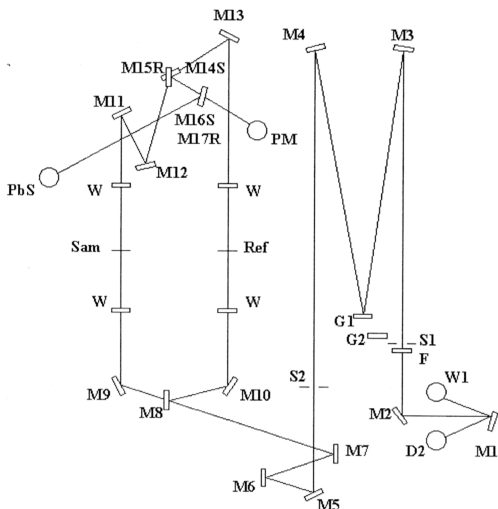

W, D2 : Light Source
 S : Slit
 G : Grating
 PbS : NIR detector
 Ref : Reference beam

M : Mirror
 F : Filter
 PM : UV/VIS detector
 Sam : Sample beam

Figure 3.6 : Optical system of Jasco V-570

output device as digital data or spectrum. Light source changeover, wavelength drive, slit drive and filter drive are controlled by the microcomputer.

The scanning procedure starts by placing one glass substrate in the sample holder and another similar glass in the reference holder and performing base line correction. The base line operation is to perform background correction over a certain selected wavelength range. The reference glass is then replaced by the sample and the transmission scanning is obtained over the selected range of wavelength.