



8-2012

## **Development and Use of a Simple Test Method to Evaluate Reheat Cracking Sensitivity in the Weld Deposit Region of a Submerged Arc Weld**

Maxwell Calder Trent  
mtrent2@utk.edu

Follow this and additional works at: [https://trace.tennessee.edu/utk\\_gradthes](https://trace.tennessee.edu/utk_gradthes)



Part of the [Metallurgy Commons](#), and the [Structural Materials Commons](#)

---

### **Recommended Citation**

Trent, Maxwell Calder, "Development and Use of a Simple Test Method to Evaluate Reheat Cracking Sensitivity in the Weld Deposit Region of a Submerged Arc Weld. " Master's Thesis, University of Tennessee, 2012.

[https://trace.tennessee.edu/utk\\_gradthes/1289](https://trace.tennessee.edu/utk_gradthes/1289)

This Thesis is brought to you for free and open access by the Graduate School at TRACE: Tennessee Research and Creative Exchange. It has been accepted for inclusion in Masters Theses by an authorized administrator of TRACE: Tennessee Research and Creative Exchange. For more information, please contact [trace@utk.edu](mailto:trace@utk.edu).

To the Graduate Council:

I am submitting herewith a thesis written by Maxwell Calder Trent entitled "Development and Use of a Simple Test Method to Evaluate Reheat Cracking Sensitivity in the Weld Deposit Region of a Submerged Arc Weld." I have examined the final electronic copy of this thesis for form and content and recommend that it be accepted in partial fulfillment of the requirements for the degree of Master of Arts, with a major in Materials Science and Engineering.

Carl D. Lundin, Major Professor

We have read this thesis and recommend its acceptance:

Carl J. McHargue, John D. Landes

Accepted for the Council:

Carolyn R. Hodges

Vice Provost and Dean of the Graduate School

(Original signatures are on file with official student records.)

**Development and Use of a Simple Test Method to Evaluate Reheat  
Cracking Sensitivity in the Weld Deposit Region of a Submerged Arc  
Weld**

**A Thesis Presented for the Master of Science Degree  
The University of Tennessee, Knoxville**

**Maxwell Calder Trent**

**August 2012**

## **Acknowledgements**

This thesis and work were made possible through the continued support and guidance by Dr. Carl D. Lundin. Sincere appreciation is extended to the committee members, Dr Carl J. McHargue and Dr. John D. Landes.

The author is very thankful for to the continued encouragement and help provided by his fellow graduate students notably D. Joshua Burgess. Last, but not least, this work would not have been possible if not for the continued assistance provided by the extensive support staff at the University of Tennessee.

## **Abstract**

Several fabricators have recently noted the occurrence of reheat cracking in the weld deposits of 2¼ [two and one fourth]Cr-1Mo-¼ [one fourth]V (22V) during the fabrication of pressure vessels used in the petrochemical industry. Due to increased oversight now required during fabrication of already expensive pressure vessels, studies have commenced worldwide in an effort to identify root causes and formulate mitigating actions to weld reheat cracking issues. The Materials Joining Group (MJG) at the University of Tennessee at Knoxville (UTK) have adapted an existing reheat cracking test originally developed for use with alloys similar to 22V. This original C-Ring test was used successfully, and as such, has set the foundation for the development of the modified C-Ring discussed in this report. A modified test, the Notched C-Ring Reheat Cracking Test (NCRRCT) has been developed. The NCRRCT is able to accurately rank 2¼ [two and one fourth]Cr-1Mo-¼ [one fourth]V (22V) weld deposits for reheat cracking susceptibility, and in doing so identify 22V weld deposits susceptible to reheat cracking before issues arise during fabrication. The NCRRCT meets all of the attributes of the so-called “Ideal Weldability Test”, in that it shows a direct correlation with actual fabrication, yields reproducible results, highlights small changes in testing variables,

clearly demonstrates the effects of welding related variables (i.e., weld design and heat input), is economical, and applies to all welding processes [1].

# Table of Contents

Acknowledgements.....	ii
Abstract.....	iii
<b>List of Tables.....</b>	<b>ii</b>
<b>List of Figures.....</b>	<b>iii</b>
Introduction.....	1
I. Literature Review.....	5
Reheat Cracking.....	5
Carbide Formation.....	17
Cr-Mo Steels.....	21
2¼Cr-1Mo-¼V (22V).....	22
Chemical Composition.....	27
Chromium.....	29
Molybdenum.....	30
Vanadium.....	31
Carbon.....	32
Manganese and Silicon.....	32
Titanium.....	33
Niobium.....	34
Tungsten.....	34
Tramp Elements.....	34
Phosphorus.....	35
Sulfur.....	36
Antimony.....	36
Lead and Bismuth.....	37
Nickel.....	37
Calcium.....	38
Aluminum.....	38
Mitigation of Reheat Cracking.....	39
Reheat Cracking Testing Techniques.....	41

II. Development of the Notched C-Ring Reheat Cracking Test (NCRRCT) for use with 22V SAW Weld Deposits.....	47
Overview of Past Work Performed by UT MJG Related to Reheat Cracking in Cr-Mo Alloys.....	47
III. Preliminary Study of Fracture Surface Morphology in 22V.....	54
Reheat Cracking in 22V Weld Deposit.....	58
Hydrogen Assisted Cracking in 22V Weld Deposits.....	63
Comparison of Reheat and Hydrogen Assisted Crack Morphologies.....	66
Conclusions From the 22V Fractography Morphology Study.....	72
IV. Experimental Procedures.....	73
Welds used in Study.....	73
Sample Extraction.....	76
Sample Production and Preparation.....	78
Equipment.....	82
Using the NCRRCT to test for Reheat Cracking Susceptibility.....	83
V. Results and Discussion.....	88
VI. Conclusions.....	11
VII. Future Work.....	13
List of References.....	14
Appendix.....	19
The protocol for employing the notched C-Ring reheat cracking test to determine reheat cracking sensitivity of SAW Cr-Mo-V weld deposits.....	20



## List of Tables

Table 1. Partial list of distribution coefficients in delta iron [26].	8
Table 2. Notation of carbides present in Cr-Mo-V steels [28].	18
Table 3. Carbide changes as a function of chemical composition, tempering time, and tempering temperature in Cr-Mo-V steels [28].	18
Table 4. 22V alloy compared to similar Cr-Mo alloys used in the production of pressure vessels. Note the superior performance of 22V in all categories [51].	24
Table 5. Calculated notched C-Ring reheat cracking sample test deflections calculated using (ASTM G-38) and a wall thickness at the root of the notch.	84
Table 6. Reheat sensitivity rankings of Cr-Mo steels using the notched C-Ring reheat cracking test	89
Table 7. Selected chemistry for 18 weld deposits used in study.	91
Table 8. Chemical analysis, reheat cracking factor “K”, and NCRRCT sensitivity ranking for the 18 weld deposits used in development of the NCRRCT.	95

## List of Figures

Figure 1. Microstructural changes from austenite in two adjacent grains leading to reheat cracking due to the precipitation strengthening mechanism, adapted from Nawrocki [38].	10
Figure 2. Influence of time and temperature on relieving stress.	13
Figure 3. Baker and Nutting illustrate the sequence of carbide formation in Cr-Mo steel [48].	19
Figure 4. Time to creep rupture verses vanadium content.	25
Figure 5. Successive steps for production of base metal HAZ C-Ring specimens.	52
Figure 6. Cr-Mo-V base metal HAZ notched C-Ring.	53
Figure 7. UT- Modified hydrogen sensitivity test specimen is shown at the left and test fixture at right.	57
Figure 8. Weld cross-section of narrow groove SAW weld used in This study, Noren's Reagent submerge for 8 sec, 6X [71].	58
Figure 9. SEM of the reheat crack surfaces of the coarse grained region of the 22V SAW weld 1 deposit.	59
Figure 10. SEM of the reheat crack surfaces of the fine grained region of the 22V SAW weld 1 deposit.	61
Figure 11. SEM micrographs of the polished and etched surface perpendicular to the 22V SAW weld 1 deposit.	62
Figure 12. SEM micrographs of the RHC polished and etched surface perpendicular to the notch in the 22V SAW weld 2 deposit.	63
Figure 13. SEM of the HAC surfaces in GTAW weld deposit of the 22V SAW weld 1 deposit.	65
Figure 14. SEM of the HAC surfaces in the GTAW weld deposit of the 22V SAW weld 2 deposit.	66
Figure 15. SEM comparison of the HAC and RHC surfaces in the weld fusion zone of the 22V SAW weld 1 deposit.	67
Figure 16. SEM comparison of the HAC and RHC surfaces in the weld fusion zone of the 22V SAW weld 1 deposit.	68
Figure 17. SEM comparison of the HAC and RHC surfaces in the weld fusion zone of the 22V SAW weld 1 deposit.	69
Figure 18. SEM comparison of the HAC and RHC surfaces in the weld fusion zone of the 22V SAW weld 2 deposit.	70
Figure 19. SEM comparison of the HAC and RHC surfaces in the weld fusion zone of the 22V SAW weld 2 deposit.	71
Figure 20 SEM comparison of the HAC and RHC surfaces in the weld fusion zone of the 22V SAW weld 2 deposit.	72
Figure 21. Typical 22V SAW weld produced for use in the development of the NCRRCT.	74
Figure 23. A notched C-Ring reheat cracking test specimen showing the correct placement of the notch traversing several overlapping weld bead passes in a narrow gap weld deposit, ~4X.	77
Figure 24. Schematic extraction of C-Ring samples from a narrow gap SAW butt weld and a general "Vee" groove butt weld geometry.	78

Figure 25. Weld cross-section of narrow gap SAW in the as welded condition, Noren's reagent, 6X [71]..... 79

Figure 26. Schematic of a C-Ring with dimensions..... 80

Figure 27. A tested C-Ring after cleaning in a 50/50 hydrochloric acid/water solution showing a typical cracking at the root of the notch,6X and 50X. .... 85

Figure 28. Relationship between cryo-cracked specimen fracture surface appearance and microstructure at the root of the notch. .... 9

## Introduction

Although other service applications exist, the 22V (2¼Cr-1Mo-¼V steel) pressure vessels are most often utilized for hydrocrackers by the petrochemical industry. Hydrocrackers are pressure vessels used in the refining process of transforming the complex hydrocarbon chains in crude oil into derivative hydrocarbons under the influence of high heat, pressure, and a catalyst. Hydrocarbons refined in these vessels make up the majority of consumable carbon fuel products. Reliable hydrocrackers are tantamount to the production of essential consumable fuels such as diesel fuel, gasoline, and jet fuel [2].

Hydrocrackers are subject to extreme and often potentially harmful environments. Service temperatures are in the 400°C-454°C (750°F-850°F) range and hydrogen partial pressures can be above 10MPa (1450psi)[3]. Standard Cr-Mo steels have been used in the production of pressure vessels since the 1960s. The pressure vessels produced prior to the widespread use of 22V were not susceptible to weld deposit reheat cracking. In these early pressure vessels the coarse-grained base metal heat affected zone (CG BM HAZ) was prone to reheat cracking. However, the vanadium modified alloy (22V) provides superior performance over the earlier Cr-Mo steels due to superior mechanical properties and offers the

added benefit of enhanced resistance to hydrogen assisted cracking (HAC). These enhanced properties are possible due to the formation of finely dispersed vanadium carbides which increase strength and traps diffusible hydrogen which can potentially lead to HAC. Though the vanadium addition also makes the 22V alloy susceptible to weld deposit reheat cracking. The first 22V hydrocracker was produced in 1996 and has since become the most widely used material for hydrocrackers in the petroleum industry [3].

Weldments in 22V pressure vessels use matching chemistry weld deposits and base metal. The 22V welds have the same thermal expansion coefficients, creep strength and resistance to HAC as the 22V base metal. This facilitates uniform thermal expansion and contraction of the vessel during each start-up and shut-down cycle of the refining process. The 22V weld deposits will also creep at similar rates as the base metal prolonging the service life of the vessel. While 22V welds require a higher Level of oversight to meet the welding requirements inherent to using this material, these matching weld deposits are necessary to maintain component integrity and safety during the refining process for the duration of the vessel's lifetime.

In 2008, the occurrence of cracking in 22V submerged arc weld (SAW) deposits in pressure vessels was reported. These weld deposit cracks were characterized by “clusters of fine transverse intergranular cracks within the weld deposits.” The cracks were described as intergranular with the cracks propagating through the full thickness of the weldment [4]. Cracking, during fabrication, is a high priority issue for the petroleum industry as many 22V vessels are currently in production and many more will be produced in the foreseeable future. Many of these discontinuities have been classified as reheat cracks due to the metallurgical and geometric characteristics. Because of the speculation that harmful tramp elements become entrained in the weld deposit, and lead to reheat crack formation, recent studies have focused on welding consumables as the culprit [5, 6].

The recent fabrication issues in 22V have prompted the Materials Joining Group (MJG) at the University of Tennessee, Knoxville (UTK) to become involved with the study of 22V, specifically the development of a modified test to rank the susceptibility to reheat cracking in 22V weld deposits. UTK has a long and successful history in the study of Cr-Mo steels used in the petroleum industry in partnership with the Department of Energy (DOE), The Welding Research Council (WRC), and the Materials

Property Council (MPC)[7-22]. The modified test, NCRRCT, will provide the petrochemical industry with an economical method of identifying welding consumables and practices that are potentially susceptible to reheat cracking.

The research documented herein is divided into six parts.

- Part I is a literature review of reheat cracking in Cr-Mo steels and is aimed to give the reader a background for the development initiatives appropriated by the UTK MJG and conclusions drawn in the remainder of this report.
- Part II covers the history, development, and use of the NCRRCT.
- Part III discusses a preliminary study performed to identify fracture surface morphology in 22V materials.
- Part IV outlines the experimental procedures utilized in this study.
- Part V covers the results and discusses the findings.
- Part VI provides the conclusions from the development of the NCRRCT.

- Part VII anticipates future work to further the development of the NCRRECT and understand the phenomena of reheat cracking

## **I. Literature Review**

### **Reheat Cracking**

Reheat cracking is also known as stress relief cracking, post weld heat treatment (PWHT) cracking, and stress rupture cracking. Reheat cracking is a potential issue in Cr-Mo alloys, including the 22V alloy. Paradoxically, the same factors that enhance these alloys' properties also cause susceptibility to reheat cracking. Cr-Mo steels containing less than 3% Cr are generally understood to be susceptible to reheat cracking [23, 24]. Erwin and Kerr noted that “[reheat] cracking is manifested by low rupture ductility and intergranular fracture along prior austenite grain boundaries, typically occurring in the coarse grained HAZ and occasionally in the weld metal, after an initially sound weldment has been subjected to a postweld heat treatment [25].” Though reheat cracking is generally associated with the coarse grained base metal heat affected zone (CG BM HAZ), this work will focus on the study of reheat cracking in 22V weld deposits. Reheat cracking occurs during a PWHT when stress relief takes



place due to the lowering of the yield strength and carbide formation (that was originally prevented due to the rapid cooling of the weldment) takes place and grain boundaries are weakened, allowing cracks to form [25].

Reheat cracking is characterized by intergranular fracture, therefore, it can be concluded some mechanism is present that weakens the grain boundaries. The mechanism weakening the grain boundaries is a point of contention in the welding research community.

The superior mechanical properties of Cr-Mo weldments are attained through the formation and growth of carbides, though these carbides are directly related to the reheat cracking potential. The segregation of the carbide forming elements in the solid as the molten weld deposit rapidly cools can be described by the distribution coefficient, “k” The distribution coefficient defines the propensity for elements to solidify either in the grain interiors or at the grain and dendrite interstices. “K” is determined by calculating the ratio of the elemental concentration in the solid ( $C_S$ ) divided by the elemental concentration in the liquid ( $C_L$ ) using an equilibrium phase diagram [26].

Most elements in iron exhibit a “K” value less than 1, and thus have a tendency to segregate to the grain boundaries and at dendrite boundaries.

Those elements in iron having the smallest “K” have the greatest effect on segregation. Alloying elements (i.e., chromium, molybdenum, and vanadium) which act to strengthen the alloy have distribution coefficients close to 1 and thus do not have a high tendency to segregation to grain and dendrite boundaries. Tramp elements (i.e., sulfur, phosphorus, and boron) have distribution coefficients near zero and thus exhibit a high propensity to segregate to grain boundaries during solidification [27]. Solidification segregation of these elements results in boundary enrichment and they do not act to strengthen the matrix. For example, distribution coefficients of some common alloying elements and common tramp elements in delta iron are provided in Table 1. Delta iron is the initial phase to form during solidification. Once solidification has occurred, the diffusion of substitutional alloying elements is minimized due to the rapid cooling of the weld.

**Table 1. Partial list of distribution coefficients in delta iron [27].**

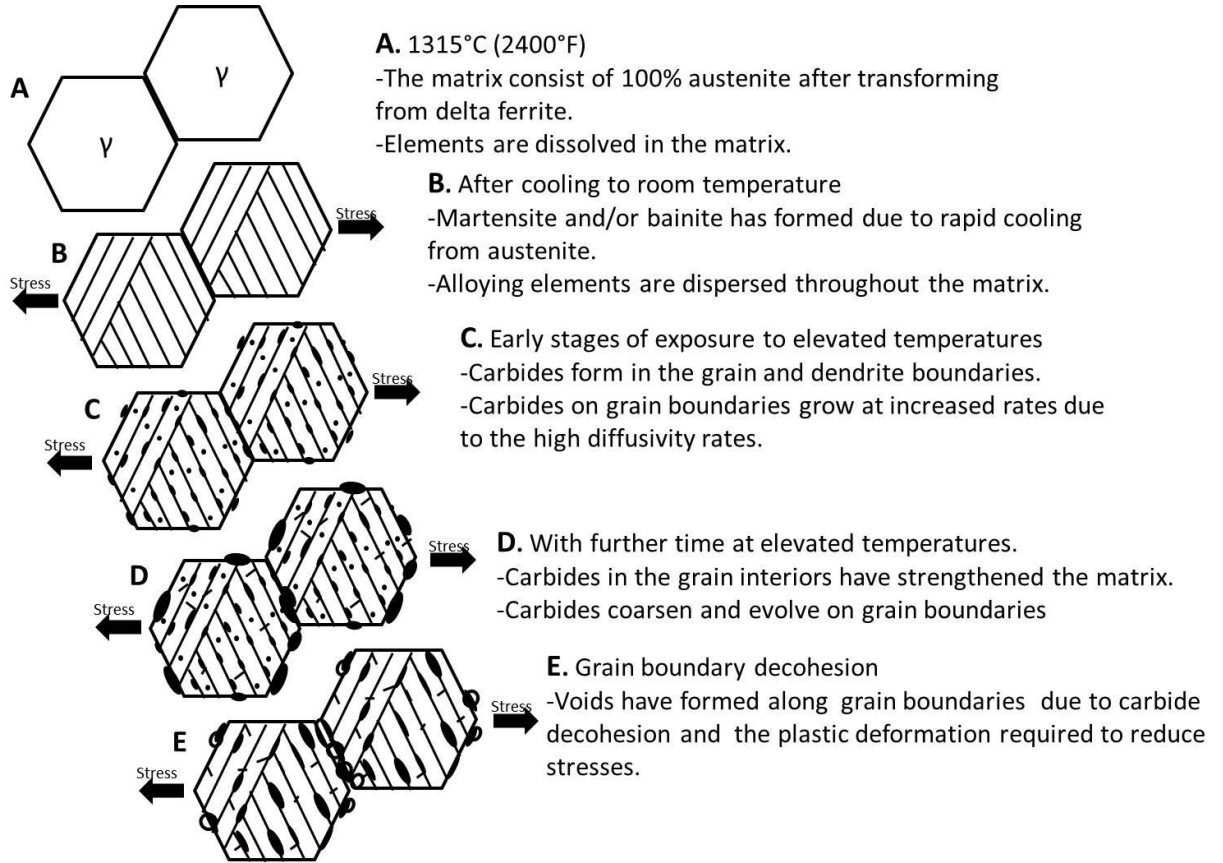
Element	Distribution Coefficient, $k$ , For given elements in delta iron
Chromium	0.95
Molybdenum	0.80
Vanadium	0.90
Aluminum	0.92
Cobalt	0.90
Tungsten	0.95
Manganese	0.84
Nickel	0.80
Copper	0.56
Hydrogen	0.32
Boron	0.05
Nitrogen	0.28
Oxygen	0.02
Phosphorus	0.13
Silicon	0.66
Sulfur	0.02
Titanium	0.14

Upon PWHT or exposure to elevated service temperatures, carbides that strengthen the matrix precipitate at dislocations in the grain interiors. These fine, uniformly distributed carbides consisting of chromium, molybdenum, and vanadium strengthen the grain interiors [28]. Several studies have noted secondary hardening of the grain interiors [15, 21, 29-31]. These carbides are coherent or semi-coherent with the iron matrix and are known to be stable for prolonged times at elevated temperatures [31-34]. Carbides also form along grain boundaries. However, the grain

boundaries are enriched with tramp elements as well as the principal alloying elements. Higher diffusion rates along grain boundaries enable carbide coarsening. Grain boundary carbides become incoherent with the grain matrix because high diffusivity paths along the grain boundaries allow carbide evolution to occur at a greater rate than in the grain interiors. Thus, strain in the weldment must be accommodated in the weakened the grain boundaries as opposed to the grain matrix which possesses a greater strength. As this process proceeds, the ratio of grain matrix strength to grain boundary strength increases, and strains at the grain boundaries increase, especially if the grains are large (i.e., less grain boundary area). This strain accumulation along grain boundaries can potentially cause intergranular cracking [28, 35].

In order for residual stresses to be relieved, the yield strength must be decreased, which naturally occurs at elevated temperatures, forcing plastic flow to occur along grain boundaries leading to rupture of the grain boundary. Reheat cracking can thus occur when the grain boundaries cannot accommodate local strains. As a precursor to grain boundary rupture, cavitation and voids form along the grain boundaries by particle decohesion which, coupled with grain boundary strain, eventually leads to intergranular rupture [6, 12, 32, 36-38]. Figure 1 details the microstructural

changes leading to reheat crack formation caused by precipitation strengthening and particle decohesion.



**Figure 1. Microstructural changes from austenite in two adjacent grains leading to reheat cracking due to the precipitation strengthening mechanism, adapted from Nawrocki [39].**

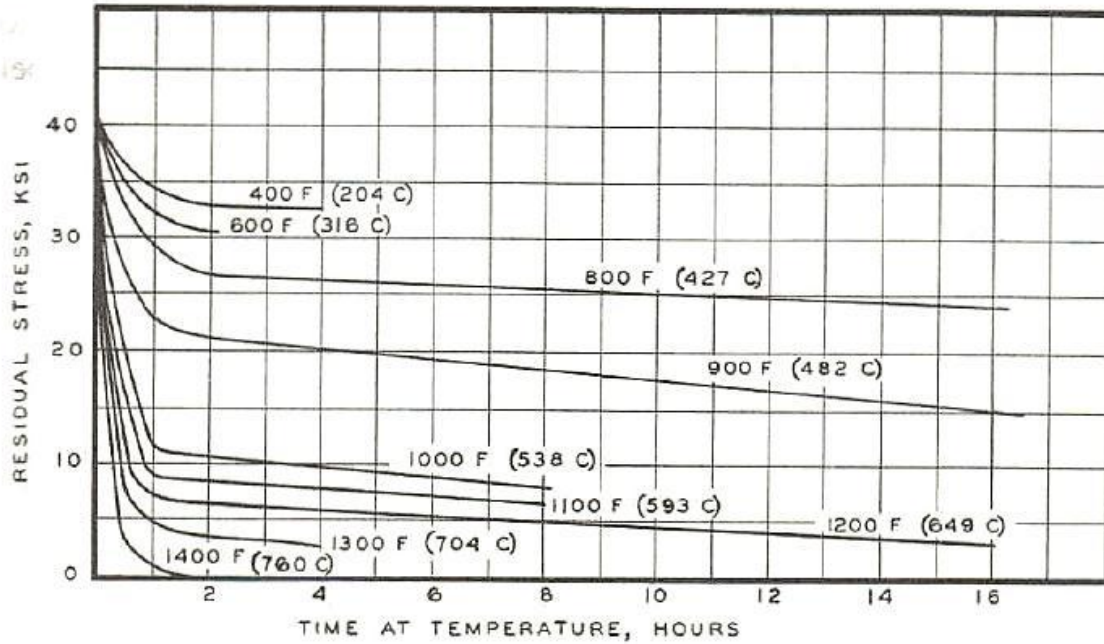
In the late 1960's, B. A. Glossop was one of the first researchers to note the susceptibility of Cr-Mo-V weldments to reheat cracking [40]. His work was predicated on the microstructure analysis of cracked Cr-Mo-V weldments. Carbides along grain boundaries were found to be initiation sites for cavities, eventually leading to decreased ductility along weakened grain boundaries. Lundin et al.'s extensive studies noted coarsened, incoherent  $M_3C$  carbides on grain boundaries of Cr-Mo alloys susceptible to reheat cracking while vanadium, tungsten, and chromium carbides formed in the grain interior leading to matrix strengthening [15, 21, 41]. Nawrocki's recent studies have re-confirmed that reheat cracking is initiated by voids due to the incoherency of  $M_3C$  carbides on prior austenite grain boundaries in 2 ¼Cr-1Mo alloys and in HCM2S (a ferritic alloy steel) [31].

Formation of a denuded region along grain boundaries has been proposed in several studies. Due to diffusion and grain boundary migration, these zones/regions are thought to be devoid of the alloying elements originally added to promote strengthening of the grain matrix. Hardness studies have noted that this denuded region is significantly softer than the carbide-rich grain boundaries and interiors [12, 35, 38, 42, 43]. These studies further suggest that the softer regions are susceptible to

cavitation and rupture, as the localized strain accumulated during stress relief is concentrated in those regions.

In a study by Edwards, a low chromium, high vanadium steel exhibited a denuded zone prior to stress relief cracking [35]. However, this study focused on Cr-Mo-V alloys subjected to a solution treatment of 1150°C and noted that Cr-Mo-V steels without the solution treatment did not exhibit a denuded zone. Studies by Lundin, Meitzner, and Pense found no correlation between the denuded regions and reheat cracking [9, 36]. In Lundin's extensive studies, reheat cracking occurred after only minimal amounts of time (1-30 minutes in some cases) upon reaching critical temperatures (567-678°C (1050-1250°F)) which would not allow the necessary time for a denuded region to form [12, 15, 44]. Swift elaborated by noting that the denuded zones only formed after a significant amount of time at an elevated temperature where the strains necessary to drive reheat cracking would have already been relieved [32]. It is important to note that at elevated temperatures, stresses are relieved through a recovery and relaxation process in which plastic deformation of grains and grain boundary sliding occur due to elevated temperatures lowering the matrix's yield strength, allowing deformation to take place. Linnert showed that this recovery and relaxation process occurs quickly (within an hour of

reaching an elevated temperature) thus significant denuded zones do not have sufficient time to form (see Figure 2) [45].



**Figure 2. Influence of time and temperature on relieving stress. Stress was greatly reduced in the first 2 hours of tempering of a mild carbon steel in a study by Linnert [45].**

The embrittlement of grain boundaries by preferential segregation of tramp elements has been shown to be a precursor to reheat cracking [29, 31, 34]. This theory was noted after differences in reheat cracking sensitivity were found to deviate on a heat-to-heat basis. A wide variety of tramp elements are considered to promote grain boundary weakening. Solute rejection during solidification causes tramp elements to be enriched



at the grain boundaries. Tramp elements have low distribution coefficients in iron or are completely immiscible in iron indicating a strong propensity for grain boundary segregation (see Table 1). Interactions between tramp elements and other alloying elements are considered to hamper the formation of more coherent carbides along grain boundaries. Hipsley observed the formation of micro-voids due to manganese sulfides that precipitated on grain boundaries [46]. In an extensive study of Cr-Mo steels, Lundin et al. noted that phosphorus was found on fracture surfaces of embrittled grain boundaries, though it was also observed that carbide evolution played a significant role in reheat cracking [15, 21]. A recent study by Heo et al. proposed a similar mechanism wherein tramp elements, notably phosphorus, embrittle grain boundaries by forming on incoherent carbide surfaces subsequently forming cracks along the carbide-grain boundary interface [34]. Conversely, Nawrocki et al. noted that tramp element segregation did not play a role in reheat cracking of a ferritic alloy steel (HCM2S) [31]. Thus, there is still controversy as to the reheat cracking mechanism in the welding research community.

The theory of reheat cracking in steels is a complex phenomenon due to the many variables and unknowns. As a result, Vinckier and Dhooge theorized a combination of mechanisms wherein segregation of tramp

elements combined with precipitation strengthening is necessary for reheat cracking to occur [47]. These findings are mirrored by several other studies noting that precipitation strengthening and impurity segregation are directly correlated with reheat cracking [15, 21, 34]. Though the details of reheat cracking are not fully understood, an extensive literature review and the author's findings suggest that a mixed mode involving both precipitation strengthening and tramp element segregation is the most plausible mechanism describing this reheat cracking.

There are other known factors that contribute to the formation of reheat cracks. The presence of a stress riser is acknowledged as a necessary requirement for the initiation of reheat cracks. A stress riser may be metallurgical or geometric in the form of a weld defect, discontinuity, or dislocation pile-up [12]. The stress riser magnifies residual stresses already present in a restrained weldment due to expansion and contraction of the weld region during fabrication. The microstructure of the HAZ or weld deposit also plays an important role in reheat cracking. The weldment must contain a susceptible microstructure to form reheat cracks. Bainite and/or martensite are required for the formation of reheat cracks. Studies have differed in the identification of which one exhibits the highest susceptibility. Meitzner and Pense identified martensite and lower bainite

to be more prone to reheat cracking than upper bainite, while other studies have shown that bainitic structures are more prone than martensitic structures [36, 48]. Despite these differences in the uncertainties, the presence of a stress riser coupled with a susceptible microstructure causes the development of reheat cracks.

Ito and Nakanishi have developed five simplistic requirements for the formation of reheat cracks [48].

1. The material must have undergone a thermal cycle that results in solutionization of alloying elements.
2. For HAZ regions, grain growth must have occurred as a result of exposure to elevated temperatures induced by a welding process.
3. Re-exposure at an elevated temperature above 620°C (1148°F)
4. Grain strength and internal stresses must exceed the strength of the grain boundaries
5. A stress riser must be present to initiate cracking.

## **Carbide Formation.**

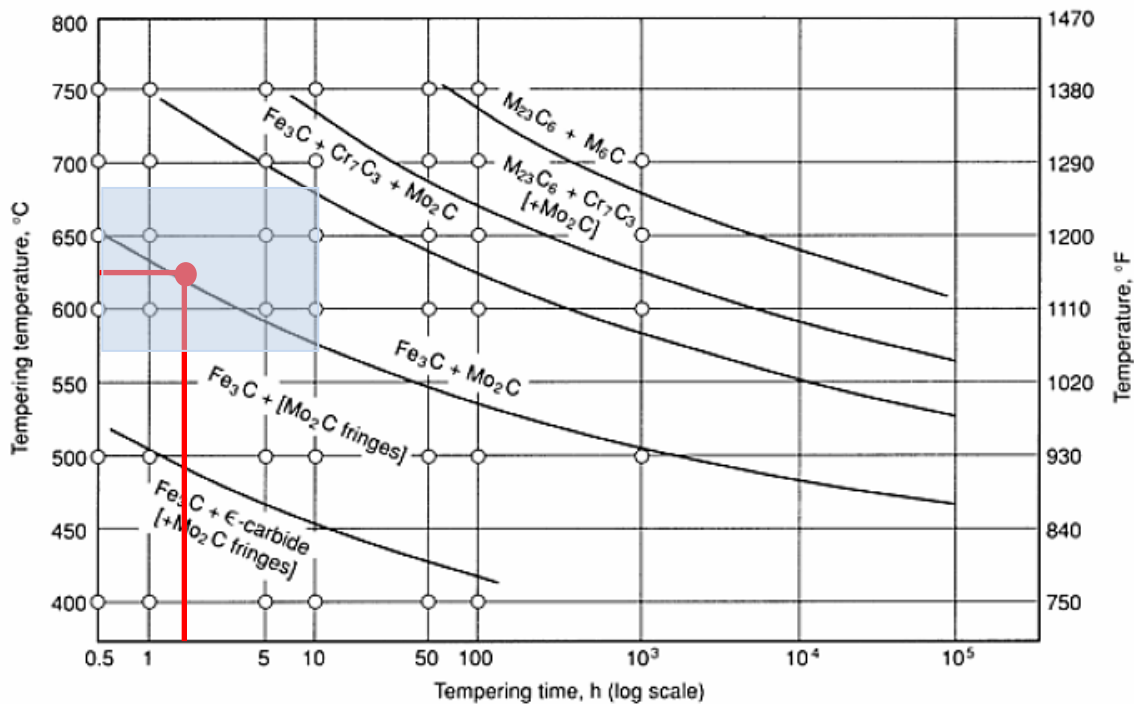
Carbides are present in all steels and directly influence the mechanical properties. Carbides form in the grain matrix as elements in solution diffuse and/or coalesce to discontinuities (such as dislocations and stacking faults) in the grain interiors and at grain boundaries. The type, amount, and evolutionary cycle of carbides are dictated by several factors such as starting microstructure, tempering temperature, and time at temperature [49]. Different alloying elements react with carbon to form a variety of carbides, each with different properties and varying interactions in the matrix. The original forms of the carbides are as follows:  $\text{Fe}_3\text{C}$ ,  $\text{Mo}_2\text{C}$ ,  $\text{Cr}_7\text{C}_3$ ,  $\text{V}_4\text{C}_3$  or  $\text{Cr}_{23}\text{C}_6$ , but these carbides may also contain atoms of different elements. For this reason, general notations have been derived to designate the different carbides. Table 2 gives the proper notation for each of the carbides in Cr-Mo steels [29]. Tamaki's extensive work has identified the general tempering stage for these carbides to precipitate in the matrix (Table 3)[29]. Baker and Nutting also proposed a sequence of carbide formation which can be found in Figure 3 [49].

**Table 2. Notation of carbides present in Cr-Mo-V steels [29].**

Original Form of Carbide	$\text{Fe}_3\text{C}$	$\text{Mo}_2\text{C}$	$\text{Cr}_7\text{C}_3$	$\text{V}_4\text{C}_3$	$\text{Cr}_{23}\text{C}_6$ and $\text{Fe}_{21}\text{Mo}_2\text{C}_6$
Notation of Carbide in Cr-Mo Steel	$\text{M}_3\text{C}$	$\text{M}_2\text{C}$	$\text{M}_7\text{C}_3$	$\text{M}_4\text{C}_3$	$\text{M}_{23}\text{C}_6$

**Table 3. Carbide changes as a function of chemical composition, tempering time, and tempering temperature in Cr-Mo-V steels [29].**

Elemental Levels			Tempering Stage		
Cr	Mo	V	Early ( $<1105^\circ\text{F}$ and $<1\text{Hr}$ )	Middle ( $>1105^\circ\text{F}$ and $>1\text{Hr}$ )	Final ( $>1105^\circ\text{F}$ and $>10\text{Hr}$ )
Low	Low	High	$\text{M}_3\text{C}$	$\text{V}_4\text{C}_3$	$\text{V}_4\text{C}_3$
Low	High	Low	$\text{M}_3\text{C}$	$\text{M}_2\text{C}$	$\text{M}_{23}\text{C}_6$
High	Low	Low	$\text{M}_3\text{C}$	$\text{M}_7\text{C}_3$	$\text{M}_7\text{C}_3$ or $\text{M}_{23}\text{C}_6$



**Figure 3. Baker and Nutting illustrate the sequence of carbide formation in Cr-Mo steel [49]. The blue box indicated the reheat cracking susceptible zone. Red lines show the approximate testing time (2 hrs) and temperatures (567-678°C (1050-1250°F)) of the Notched C-Ring Reheat Cracking Test.**

J.E. Indacochea and others have provided summarized descriptions of many of the carbides [50]:

- $-M_3C$  is a derivative of  $Fe_3C$  and is one of the most common carbides found in Cr-Mo steels. This carbide has been shown in many studies to be the most relevant to reheat cracking [15, 16, 21, 31].

- $-M_7C_3$  is a chromium carbide ( $Cr_7C_3$ ), though it is known to dissolve Fe, Mn, Mo, V and Ni.  $M_7C_3$  is known to form on interfaces between other carbides and the ferrite matrix.
- $-M_{23}C_6$  is based on another chromium carbide,  $Cr_{23}C_6$ , and dissolves V and Ni. Baker and Nutting found  $M_{23}C_6$  throughout the matrix in quenched and tempered 2¼Cr-1Mo steels, but only in bainitic regions of the tempered steels [49].  $M_{23}C_6$  was found to have grown in the interior of the bainite regions at the expense of  $Fe_3C$  and  $Mo_2C$ .
- $-M_6C$  is a triple carbide formed from a composition varying between  $Fe_4Mo_2C$  and  $Fe_3Mo_3C$ .  $M_6C$  dissolves both Cr and V and grows rapidly on grain boundaries at the expense of surrounding carbides.
- $-M_2C$  is a molybdenum rich carbide,  $Mo_2C$ , and dissolves up to 30% Cr and V.  $M_2C$  is coherent when first precipitated though upon growth loses some of the coherency.
- $-M_4C_3$  is a vanadium carbide,  $V_4C_3$ , and dissolves Cr and Mo. It grows directly from the matrix and does not depend on the formation of other carbides [12]. Glossop noted cavitation heterogeneously nucleated at  $V_4C_3$  particles in Cr-Mo-V steels

[51]. Studies performed by Tamaki found that  $M_4C_3$  was responsible for secondary hardening in vanadium bearing steels, aiding in the precipitation strengthening of grain interiors [29].

### **Cr-Mo Steels**

The same factors that make chromium-molybdenum steels advantageous for use in petroleum industry have a detrimental effect on reheat cracking susceptibility. For this reason, the development of Cr-Mo steels has been evolving for the better part of the past century for high temperature applications where creep strength, corrosion/oxidation resistance, and hydrogen embrittlement are concerns [12]. Cr-Mo steels generally contain 0.5-9.0% Chromium and 0.5-2.0% Molybdenum [20]. The first generation of Cr-Mo steels was developed in Germany with 2.25-3.8% Cr and operated in the pressure range of 28-70MPa. This alloy was used unchanged until the 1960's when the first modern hydroprocessing reactors required the development of the second generation of the Cr-Mo alloys giving improved toughness (54 Joules at 10°C (40 ft-lbs at 50°F)). The second generation did not address temper embrittlement, so the 1970's saw the development of the third generation of Cr-Mo steels. The third generation Cr-Mo steels addressed temper embrittlement by limiting the amount of tramp elements and the development of the J-factor [3]. The



J-Factor is a parameter designed to limit tramp elements levels to reduce temper embrittlement in Cr-Mo alloys [52]. In the 1980's the J-factor was lowered further from 180 from the 1970's to 100 thus yielding better resistance to temper embrittlement and an increase in toughness in the 4<sup>th</sup> generation Cr-Mo (54 Joules at -32°C (40ft-lbs at -25°C)).

$$\text{J-Factor} = 10^4 \times (\text{P+Sn}) \times (\text{Mn+Si})$$

The 1980's and 1990's saw the development of modern alloys and incorporation of the newer alloys into power generation and process industries. The modern alloys benefit from better processing techniques and better understanding of alloying elements, toughness levels are now reaching 54 Joules (40 ft-lbs) below -40°C (-40°F) [3]. These levels were obtained by the careful addition of alloying elements such as vanadium, niobium, titanium and boron. These alloying elements form carbides, resulting in an increase in creep strength, resistance to temper embrittlement, and greater resistance to HAC. The addition of these alloying elements spawned several new alloys such as 22V, T23, and T24.

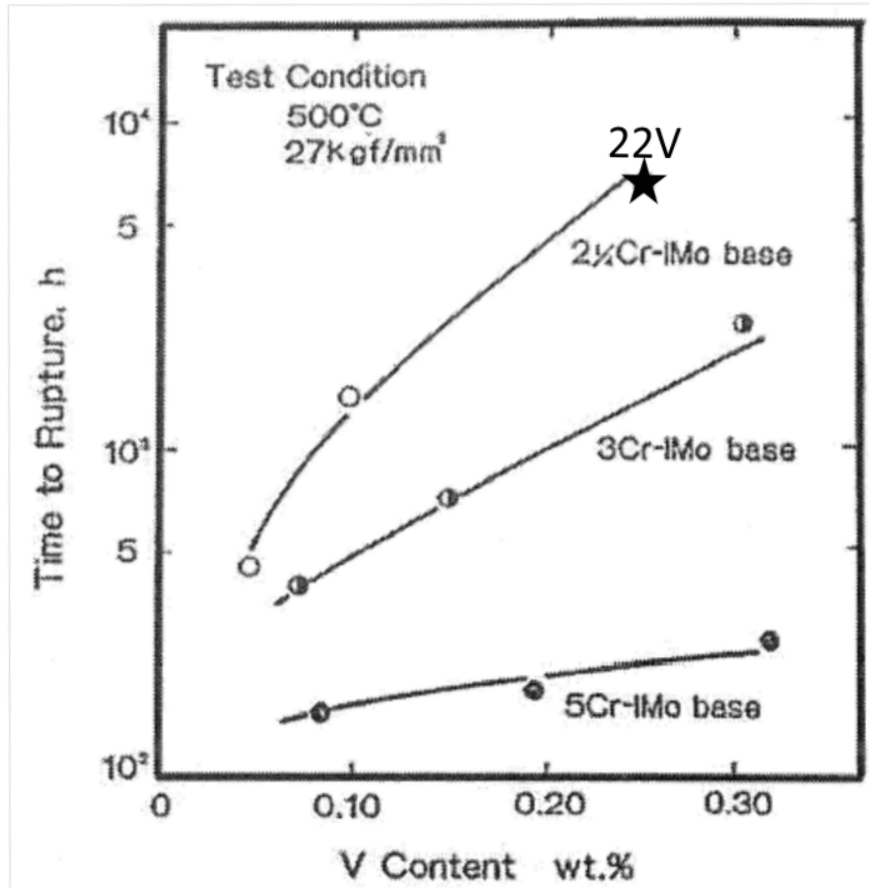
### **2¼Cr-1Mo-¼V (22V)**

2¼Cr-1Mo-¼V or 22V alloy has become an industry standard for use in refineries and petrochemical plants. 22V has several advantages over the original Cr-Mo alloys. These improvements include: enhanced tensile

strength, better creep rupture strength, and improved hydrogen resistance. These advantages are shown in Table 3 and Figure 4 . These improved properties allow fabricators to reduce the wall thickness or increase processing temperatures in the 22V pressure vessels resulting in economic benefits [52]. The 22V out performs the non-vanadium alloys due to the presence of finely dispersed vanadium carbides that are more stable than the chromium and molybdenum carbides formed in non-vanadium bearing Cr-Mo steels.

**Table 4. 22V alloy compared to similar Cr-Mo alloys used in the production of pressure vessels. Note the superior performance of 22V in all categories [52].**

Steel Grade	22V (2 ¼Cr-1Mo-¼V )	Conventional 2 ¼Cr-1Mo	3Cr-1Mo-¼V-Ti-B	3Cr-1Mo-¼V-Nb-Ca	Conventional 3Cr-1Mo
Max. Allowed Temperature ASME VIII-2	482°C	482°C	454°C	454°C	454°C
Max. Allowed Temperature API 941	510°C	454°C	510°C	510°C	510°C
Minimum Tensile Strength	586 MPa	517 MPa	586 MPa	586 MPa	517 MPa
Minimum Yield Strength	414 MPa	310 MPa	414 MPa	414 MPa	310 MPa
Design Stress Intensity Value ASME VIII-2	at 454°C 169 MPa	at 454°C 150 MPa	at 454°C 164 MPa	at 454°C 164 MPa	at 454°C 131 MPa
	at 482°C 163 MPa	at 482°C 117 MPa	-	-	-
Wall Thickness	at 454°C 298 mm	at 454°C 338 mm	at 454°C 307 mm	at 454°C 307 mm	at 454°C 392 mm
	at 482°C 310 mm	at 482°C 442 mm	-	-	-
454°C Design: Reactor Weight Typical Cost	916 Metric Tons 5.5 £ x10 <sup>6</sup>	1038 Metric Tons 5.65 £ x10 <sup>6</sup>	944 Metric Tons 5.61 £ x10 <sup>6</sup>	944 Metric Tons 5.61 £ x10 <sup>6</sup>	1203 Metric Tons 6.26 £ x10 <sup>6</sup>
482°C Design: Reactor Weight Typical Cost	953 Metric Tons 5.72 £ x10 <sup>6</sup>	1359 Metric Tons 7.39 £ x10 <sup>6</sup>	-	-	-



**Figure 4. Time to creep rupture versus vanadium content. The 22V alloy shows superior creep rupture performance compared to standard 22 and other Cr-Mo alloys [53].**

22V has been in use in the fabrication of hydrocrackers by the petrochemical industry since the late 1990's and over 200 22V reactors

had been fabricated by 2006 with more having been completed since [44]. API 934 dictates fabrication procedures using 22V and required mechanical properties. The 22V alloy is designed to be used in the quenched and tempered condition with minimum tensile strengths of 85-105 Ksi (586 -724 MPa) and a yield strength of 55-100 Ksi (379- 690 MPa) depending on the grade. Like the 5<sup>th</sup> generation of Cr-Mo steels, the impact toughness is required to meet 54 Joules (40 ft-lbs) @ 0°F (-18°C) and the J-factor is also adopted from the Cr-Mo steels to limit the presence of tramp elements.

Fabrication procedures for 22V reactors are defined in API 934 [3, 44]. A weld preheat of 177°C (350°F) is the minimum temperature allowed. The preheat limits the cooling rate thus affecting the microstructure of the base metal HAZ and the weld deposit. The preheat must be maintained until the intermediate stress relief treatment (ISR) or the final PWHT is performed. After welding, a dehydrogenation heat treatment (DHT) of 350°C (660°F) is required to remove potentially harmful hydrogen from the weld. An ISR of 650°C (1200°F) is required after the DHT to partially relieve stresses incorporated in the weldment so that the welded component may be stored before the final PWHT is performed. A PWHT of 705°C (1301°F) for a minimum of 8 hours is necessary to attain the required toughness and

remove any retained hydrogen trapped in the matrix after the initial DHT and ISR.

### **Chemical Composition**

22V gains much of its strength through the formation of coherent carbides throughout the matrix. The major alloying elements (Cr, Mo and V) are all strong carbide formers which act to form carbides during the thermal cycles experienced by the steel. These same alloying elements also make the steel susceptible to reheat cracking. Unfortunately, the restriction of these elements is not a viable option as they are necessary for the hardenability, strength, and creep resistance of the steels. It is important to remember that the majority of reheat cracking studies focused on base metal while this current study is directed at weld deposits. 22V weld deposit chemistry, as it relates to reheat cracking, is a relatively new area of study, and the body of work is limited at this point. The following section provides a basic understanding of the effects of different alloying and tramp elements with respect to reheat cracking in 22V weld deposits.

Many studies have focused on the individual effects of different alloying elements ranging from carbon, chromium and molybdenum to minor elements such as lead, niobium and aluminum [30, 54-57]. Elements that are generally considered to be detrimental to reheat cracking

susceptibility are: carbon, molybdenum, chromium, and vanadium. These elements are considered to be unfavorable, in that, they have been linked to an increase in reheat cracking susceptibility.

The formation of mathematical relationships to correlate chemical composition to reheat cracking susceptibility have been theorized since the realization of reheat cracking in Cr-Mo steels. The initial cracking susceptibility parameter by Nakamura used only Cr, Mo, and V [54]. This  $\Delta G$  parameter places emphasis on the main alloying elements in Cr-Mo steels assuming precipitation strengthening was the driving force behind reheat cracking

$$\Delta G = Cr + 3.3Mo + 8.1V - 2$$

Since then other authors have attempted to refine and better predict reheat cracking susceptibility by adding other elements into mathematical equations to predict reheat cracking. In the 80's Boniszewski proposed the MCF (metal comparison factor) for 22V material to include many minor grain embrittling elements [55]. The higher the MCF correlates to a decrease in rupture ductility.

$$MCF = Si + 2Cu + 2P + 10As + 15Sn + 20Sb$$

Recently a study by Chauvey traced reheat cracking sensitivity to tramp elements Pb, Bi, and Sb. Using those elements, a K-factor was developed to determine the susceptibility to reheat cracking [5].

$$\text{K-factor} = \text{Pb} + \text{Bi} + 0.03 \times \text{Sb} < 1.5 \text{ppm}$$

The K-factor was developed using Gleeble type reduction of area (RA) testing. A high K-factor correlated to a low RA. However, recent studies at the University of Tennessee have not encountered the same correlation between reheat cracking and composition.

Many other equations have been derived to reduce reheat cracking susceptibility in base metal heat affected zones. These equations are similar to the above mentioned  $\Delta G$  and MCF and are available in the open literature.

The following will now discuss the effect of specific elements and their roll in reheat cracking:

### **Chromium**

Chromium is one of the most important alloying elements in 22V. Alloys with less than 3% Cr are susceptible to reheat cracking. The alloys containing more than 3% Cr are not susceptible because the carbides that form in these alloys do not cause secondary strengthening [20]. Tamaki



extensively studied the effect of chromium in Cr-Mo steels noting that a chromium level of about 1% is ideal for limiting reheat cracking, and susceptibility to cracking increased with higher Cr percent [30]. Chromium is an excellent carbide former as it can be easily removed from solution during the formation of carbides [58]. Carbon level plays an important role in the movement of chromium, since chromium associates with carbon in solution. Steels with low levels of carbon see an increase in free chromium solute strengthening in the matrix. Carbides formed with chromium include  $M_7C_3$ , and  $M_{23}C_6$  which are not stable at elevated temperatures and have been noted to influence reheat cracking.

### **Molybdenum**

Molybdenum, one of the major alloying elements in 22V, increases the susceptibility to reheat cracking, but it is also the major element for the creep strength of 22V. Molybdenum is a strong carbide former and is only limited by the amount of carbon in the surrounding matrix. It has been suggested that the one of only ways to limit the Mo carbide formation is by lowering the carbon content and thus keeping the Mo in solution. Adding other elements with a higher affinity for carbon such as vanadium, titanium, and niobium can also limit the formation of Mo carbides. Other elements

such as phosphorus and/or arsenic are responsible for forming embrittling carbides with molybdenum at grain boundaries [57, 58].

Finely dispersed  $\text{Mo}_2\text{C}$  is the most effective molybdenum carbide formed for creep strength, however, with longer times at elevated temperature  $\text{Mo}_2\text{C}$  can grow and/or evolve to become detrimental as the carbides become incoherent to the matrix, and can lead to enhanced reheat cracking susceptibility [50]. Excess Mo has been traced to the formation of detrimental  $\text{M}_2\text{C}$  carbides, Jin Yu and McMahon have suggested the Mo concentration be limited to  $<0.7$  wt% [57].

## **Vanadium**

Vanadium greatly increases the strength of steels though the effect is equally detrimental to reheat cracking susceptibility. This is illustrated earlier by the  $\Delta G$  factor in which vanadium has the greatest multiplier for reheat cracking susceptibility [54]. Vanadium aids in the resistance to hydrogen embrittlement as vanadium carbides trap hydrogen where it is not able to diffuse and coalesce into amounts necessary to form cracks.

Vanadium has a great affinity for carbon, even greater than molybdenum and strengthens steel by keeping Mo in solution. Vanadium generally precipitates into  $\text{V}_4\text{C}_3$  in a uniform fine dispersion throughout the matrix [58].  $\text{V}_4\text{C}_3$  carbides give a dramatic rise to grain strength, but like the  $\text{M}_x\text{C}_y$

carbides with enough time at temperature the vanadium carbides on grain boundaries can grow and embrittlement can take place.

### **Carbon**

All steels gain their strength due to carbides formed from carbon, for this reason carbon undoubtedly plays an important role in reheat cracking.

Carbon is the principal alloying element in steel thus has a marked influence on all of the properties of the steel. Though it is often over looked in studies that involve reheat cracking it is an integral part of any carbide formation. Other elements such as molybdenum and vanadium have a great affinity for carbon thus carbides formed by these elements can be limited by the movement and amount of carbon in the matrix. There is little research to show the specific effect of carbon on reheat cracking although Ito noted that reheat cracking was much more prevalent in welds containing 0.05%-0.10% carbon but any further increase to 0.25 yielded no change in reheat cracking susceptibility [48].

### **Manganese and Silicon**

Manganese and silicon are often studied together when studying reheat cracking. There is some controversy as to the true effect of manganese and silicon on reheat cracking. A study published in *Welding in the World* showed that a manganese to silicon ratio of 2.5 to 4 decreased

susceptibility to reheat cracking [59]. In another study performed by McMahon, manganese was found to co-precipitate with phosphorus along grain boundaries increasing grain boundary embrittlement [57]. Hipsley has noted the formation of micro-void coalescence along manganese sulfides in reheat cracking studies of 2¼Cr-1Mo steels [46]. Nickel bearing steels have shown that silicon can co-segregate with nickel on prior austenitic grain boundaries. In steels with lower levels of nickel the silicon has also been shown to segregate with phosphorus to embrittle grain boundaries. Vinckier found that silicon promoted the growth of M<sub>2</sub>C carbides which have been shown in many studies to be a key carbide affecting reheat cracking susceptibility [60].

## **Titanium**

Titanium is added to steels as an alloying element, deoxidizer, and grain refiner. Studies have shown that small amounts of titanium added for deoxidizing and grain refining purposes have little effect on reheat cracking and possibly even a beneficial effect [61]. In larger amounts, titanium has been found to be slightly detrimental to reheat cracking susceptibility. These studies showed that when titanium was added as an alloying element the matrix strengthening effect can increase the reheat cracking susceptibility [62].

## **Niobium**

Niobium is known to be a strong carbide former in steels. Niobium carbides are very stable at elevated temperatures making niobium additions attractive for grain refinement. A study performed by the Kawasaki corporation showed that niobium interacted with vanadium to increase susceptibility to reheat cracking in the Y-groove test [63].

## **Tungsten**

Tungsten is a carbide forming element added to steels. Tungsten's affinity for carbon is less than that of Mo and V which allows tungsten to remain in solution where solid solution strengthening can take place. Tungsten has been shown to detrimentally affect reheat cracking in T23 welds. Park et al. correlated reheat cracking to molybdenum and tungsten levels. Welds with lower Mo levels had a higher susceptibility to reheat cracking as more tungsten was found on grain boundaries [6]. By increasing molybdenum levels the tungsten was unable to segregate and embrittle grain boundaries thus reducing reheat cracking susceptibility. Nawrocki Noted the presence of tungsten on reheat crack surfaces in Cr-Mo steels, though no direct correlation to reheat cracking was shown [31].

## **Tramp Elements**

The phenomenon of reheat cracking has been closely tied to impurity segregation of tramp elements. Many studies have concluded that different

tramp elements have detrimental effects. Tramp elements refer to elements that are unintentionally added to the Cr-Mo steel during production and/or welding. Phosphorus, copper, sulfur, tin, and many more elements have been studied in attempts to reduce reheat cracking in Cr-Mo steels. The effect of tramp elements is most likely derived from the interaction of the tramp elements with carbide formation along grain boundaries

### **Phosphorus**

Phosphorus is generally acknowledged as the most detrimental tramp element with regard to reheat cracking. Tamaki and McMahon have noted that the addition of Cr and Mo to steels decreases the solubility of phosphorus in ferrite and austenite, this is also evident by the very low distribution coefficient of phosphorus, see Table 1 [30, 57]. The lack of solubility in iron, forces phosphorus to segregate along grain boundaries. Studies have postulated different ways that phosphorus segregates to grain boundaries such as cavity formation, phosphide precipitation, and/or interaction with other grain boundary carbides. Lundin et al. found phosphorus present on grain boundaries of embrittled Cr-Mo steels using Auger spectrometry, this has been mirrored by Auger analysis in many

other studies that phosphorus is present along grain boundaries in Cr-Mo steels[15, 34, 57].

### **Sulfur**

Sulfur has been shown to increase susceptibility to reheat cracking. Sulfur segregates to dislocation tangles along boundaries generated by impurity penetration. Sulfur may be detrimental due to cavity formation along the grain boundaries penetrated by impurities. Like phosphorus, sulfur has been noted on grain boundaries by auger analysis and by low distribution coefficients [57]. Studies have shown that an excess of free sulfur can increase reheat cracking susceptibility[63]. In a study of impurity effects on 2¼Cr-1Mo steels Lewandowski and Hipsley found sulfur to be responsible for the reheat cracking using a three point bend type of test [64].

### **Antimony**

In the past, antimony has discussed in studies by Bruscatto, and Hunter involving temper embrittlement and reheat cracking [42, 56]. These studies note that high antimony levels can lead to an increase in embrittlement. In more recent work by Chauvy, Gleeble testing of 22V weld deposits concluded that antimony increases reheat cracking potential [5]. The effect of antimony on reheat cracking can be correlated by the

K-factor that was introduced by this work. The true effect of antimony in 22V weld deposits may not yet be truly understood, recent work by the author has found that 22V weldments doped with antimony alone performed better than undoped weldments with respect to reheat cracking susceptibility.

### **Lead and Bismuth**

Lead and bismuth have historically not been associated with reheat cracking in Cr-Mo steels. These early studies would have overlooked lead involvement due to the lack of lead in base metals, though lead and bismuth are tramp elements found in weld deposits. Lead and bismuth are both practically insoluble in iron and undoubtedly segregate to grain boundaries [27]. Chauvy noted the presence of lead, bismuth, and antimony to be detrimental to reheat cracking in 22V weld deposits [5]. Ongoing research by the author suggests that indeed lead and bismuth are detrimental to reheat cracking in 22V weldments. Continued study based on the proposed work is anticipated to shed further light on the role of lead and bismuth in reheat cracking in 22V alloys.

### **Nickel**

Nickel has been shown to have little to no effect on reheat cracking in Cr-Mo steels. In the many studies relating chemical composition to reheat



cracking, nickel is not normally included. This effect could be due to nickel's inability to form carbides. Any effect on carbide formation is most likely related to nickel affecting the kinetics of carbide precipitation [12, 20].

### **Calcium**

Calcium has been shown to reduce the susceptibility for reheat cracking in steels. Lundin et. al. found calcium treated 2 ¼Cr-1Mo-V steels show a low susceptibility to reheat cracking [15]. Shinya et al. added calcium to a low sulfur 22V steel and saw a dramatic increase in elongation and RA, though the results did not hold true in commercial grade 22V steels[65].

### **Aluminum**

Aluminum is a deoxidizer and grain refiner in Cr-Mo steels, but is detrimental to reheat cracking [6, 35, 38]. Studies by Park using Gleeble analysis of T23 weld deposits found that aluminum segregation led to grain embrittlement as well as formation of a denuded zone adjacent to grain boundaries [6]. Aluminum is thought to prevent grain boundary mobility by the presence of Al-N precipitate clusters. Studies have correlated an increase in  $V_4C_3$  and  $Mo_2C$  carbides to an increase in aluminum content. These carbides have been shown to be egregious for reheat cracking susceptibility[38].

## **Mitigation of Reheat Cracking**

Many researchers have proposed measures to reduce/mitigate reheat cracking in Cr-Mo weldments, though after extensive research it is apparent that the issue of reheat cracking is a combination of several complex factors [12, 20, 48, 50]. These factors include:

- Composition
- Tramp element levels
- Weld fabrication parameters
- Joint design

There is no single way to completely alleviate the problem of reheat cracking. Though, it is possible to manipulate several variables to greatly reduce the potential for reheat cracking.

The obvious solution involves material selection. By choosing an alloy that is not susceptible to reheat cracking the issue is easily avoided. For example, choosing steel with greater than 3% chromium would offer an understandable solution. Other options include choosing Cr-Mo steels with less susceptibility to reheat cracking such as 22 alloy rather than the vanadium containing version 22V. This practice is not applicable for many

situations where required properties are only obtainable through the use of specific alloys, therefore more involved measures are often observed.

As discussed earlier in this review, tramp elements can be very detrimental to reheat cracking susceptibility. Tight control of these tramp elements notably phosphorus and lead may limit the development of reheat cracks in weldments. This may be accomplished by following one of the many mathematical equations put forth that limits the amount of offending tramp elements such as the MCF.

Altering welding parameters may help to prevent reheat cracking in a weldment [12, 20]. The rationale behind these changes lies in reducing the presence of susceptible microstructure such as those found in the coarse-grained base metal HAZ and/or preventing the formation of detrimental carbides. By altering the heat input, preheat temperatures, and/or travel speed reheat cracking susceptibility may be reduced. There is some debate as to these parameters and it is quite possible that each alloy and weld design may react differently when changes are made in the welding procedure. In any case, fabricators are often bound to the parameters set forth by different codes such as API 934 for 22V weldments [3, 44].

A stress riser is almost always the initiation point of any reheat crack. By reducing the presence of any stress concentrators, weld discontinuities, and any other anomalies in the weld reheat cracks would not have an initiation point to develop. Stress concentrators may be avoided through the use of a properly designed weld joint. Weld discontinuities and other anomalies may be prevented through tight quality control during fabrication of the weldment. Further, the careful use of nondestructive inspection after a weldment has been produced and before any PWHT may also identify potential problem sites to be repaired. The removal of stress risers will provide a significant reduction in reheat crack formation.

Though reheat cracking is a complex issue in many Cr-Mo steels, tight control of weld design, proper consumable selection, and close attention to weld fabrication detail may mitigate the issues relating to reheat cracking. It is recommended that weld joint be carefully designed to reduce stress risers. Consumables should be selected to limit levels of detrimental tramp elements. Weld fabrication should be carried out to closely follow API 934.

### **Reheat Cracking Testing Techniques.**

Reheat cracking test have aimed to give the welding industry a tool to avoid the problem of reheat cracking in welds. The development of different

reheat cracking tests have progressed since the reheat cracking phenomenon was first discovered over 50 years ago. Though the type and variety of testing methodology is vast the goal is generally the same, to provide results useful to the mitigation and reduction of reheat cracking in weldments. Kammer et al. was the first to define the requirements of an ideal weld cracking test [1].

1. Ability to show a direct correlation with actual fabrication and service behavior.
2. Reproducibility of results with freedom from variation due to the human element.
3. Sensitivity to small changes in a test variable.
4. Ability to show the effects of several welding variables.
5. Economical preparation of specimens and running of test.
6. Applicability to all welding processes

Baker later enumerated on the ideal weld test to better suit reheat cracking [66]. Bakers requirements focused on reheat cracking taking

place in the base metal HAZ though the same requirements are applicable to the weld deposit.

1. The specimen should have some defect or notch in the microstructure representative of the actual weld
2. The weld should be strained in a fashion similar to an actual weld.
3. The weld should be exposed to stress relaxation similar to what an actual weld experiences.

The multitude and variety of reheat cracking tests make a complete study difficult and confusing. As of 1974, Vinckier and Pense sited and reviewed 15 different tests to determine the susceptibility to reheat cracking [33]. This study discusses reheat cracking test in a manner as to better describe the current test practices. This is necessary due to the current need to study reheat cracking in matching 22V weld deposits rather than the base metal HAZ which is the region addressed in the earlier tests.

Three different forms of reheat cracking test will be discussed. The first are tests involving the use of a welded specimen. These tests are advantageous because they are directly related to the weld and PWHT.

The drawback to complete welds lies in the reproducibility of the test and

the scale of the strain associated to a small test specimen compared to the high strain associated with large industrial welds. The second type of reheat cracking test involves a simulated weld specimen. These tests are excellent for reproducibility, predictable stress levels, and microstructure control. The simulated weld reheat cracking test fall short in that only one region of the weld may be tested and actual stresses created by a weld are not duplicated. The third type of test utilizes specimens incorporating a section of an actual weld. These tests are most closely able to duplicated actual weld conditions. The stress levels are accurate, and the entire weldment (or just a specific region) may be selected depending on the test.

Many of the welded specimen type of testing described above were first developed to study the effect of hydrogen attack on a weldment. These tests were altered to study the susceptibility of different alloys to reheat cracking. The modified implant test and Y-Groove restraint cracking test have been widely used [67]. These tests rely on a welded specimen subjected to a typical heat treatment. These past reheat cracking test were designed to test the base metal HAZ for reheat cracking susceptibility. Current issues have shown the need to develop new practices to rank the reheat cracking susceptibility of in 22V weld deposits.

The most popular RHC tests are some form of tensile or stress rupture test. Many different tests fall into this category and a majority of them incorporate a thermally simulated HAZ. Often these tests are run using a Gleeble and depend on the calculation of reduction of area (RA) to rank reheat cracking susceptibility. This type of stress rupture test can be altered to test simulated welds, actual base metal HAZ, or actual weld deposits. Simulated base metal HAZs were the focus of many early studies due to the increased susceptibility to reheat cracking. Vinckier and Pense developed a widely accepted test for simulating base metal HAZs. The test utilized 4 Levels of reheat cracking susceptibility to rank the weldments [33].

1. >15% RA – Not susceptible to RHC
2. <15% RA – Slightly susceptible
3. <10% RA – Highly susceptible
4. <5% RA - Extremely susceptible

This stress rupture test showed the ability to provide a basis for ranking the reheat cracking susceptibility of different materials.

Recently two tests have been proposed specifically to test 22V weld deposits for reheat cracking potential. The following paragraphs will focus



attention to two recently proposed reheat cracking test before proposing a modified reheat cracking test currently being developed at the University of Tennessee.

Chauvy has developed a test involving slow strain rate testing of samples machined from 22V weld deposits which eventually lead to sample rupture [5]. The test is carried out by extracting 120mm (4.7 in) cylindrical samples from a weld deposit in the longitudinal weld direction. The specimens are placed in a Gleeble and rapidly heated (within 3 min) to the desired test temperature and held for 30 min before the slow strain rate portion of the test is initiated and the specimen elongates and eventually ruptures. This uniaxial test relies on the calculation of %RA to characterize the reheat cracking potential of the weld deposit. Four samples are required to conclusively rank each consumable lot. The weld deposit chemistry from several weld deposits was determined and the relationship between ductility and chemistry were defined. The reproducibility of this test has been called into question by others including Chauvy [68].

The second test methodology published and patented by a Cr-Mo-V Fabricator [69], is a stress relaxation type of test but the entire evaluation procedure is difficult to interpret from the published document due to vague

and incomplete instructions. This Fabricator sponsored test employs a long sample that is uniaxially loaded in a proprietary testing apparatus by employing a hydraulic loading device and exposed to a simulated ISR. It is assumed that the sample is fractured using the hydraulic assembly after removal from the furnace. The specimen fracture surface is analyzed using an SEM method to determine the area percent of intergranular fracture and then the samples are sectioned for a metallurgical analysis of the weld region. In conjunction with the testing results, statistical software is used to rank the welding consumables.

## **II. Development of the Notched C-Ring Reheat Cracking Test (NCRRCT) for use with 22V SAW Weld Deposits**

### **Overview of Past Work Performed by UT MJG Related to Reheat Cracking in Cr-Mo Alloys**

The Materials Joining Group at the University of Tennessee has been involved with both pragmatic and in-depth metallurgical studies of the reheat cracking sensitivity of a wide variety of steels since the 1970's. These studies have involved, among others, SA 517, A 514, SA 533, SA 508, A 710, SA 736, 1-1/4Cr, 2-1/4Cr, 3Cr, 9Cr, together with the vanadium modifications of the 3Cr-Mo, 9Cr-Mo-V-Nb and 2-¼Cr-1Mo-V (22V) [7-22]. As was the case for other early investigations, the reheat cracking

sensitivity in the coarse-grained base metal HAZ was of the most interest. This emphasis resulted from the fact that many of the weld metals were not generally selected to match the base metal composition. However, in the current concerns for 22V SAW weld deposits, the filler metal, was selected to closely match the base metal so that the creep strength, thermal expansion, and hydrogen resistance are comparable.

A majority of the early studies involved the Gleeble and the simulation of the HAZ followed by a constant load test of the simulated coarse-grained HAZ region, with the test temperature selected to fall within the reheat cracking range of 1050°F-1250°F (567°C-678°C) [7-13]. These studies proved very useful and a comparative ranking could be obtained which placed the subject steels on a simple sensitivity scale [7-15]. However, to more adequately study the mechanisms involved with a materials sensitivity to reheat cracking other test methods needed to be employed which more closely duplicated actual weldment behavior with regard to a quantified assessment of all weld deposit and HAZ regions and their change in sensitivity with postweld heat treatments. Further, it was axiomatic that both stress relaxation and notch effects should be considered. The effect/necessity of a weld discontinuity, resulting in a notch (physical or

metallurgical) in the most sensitive region of a weld, became a clear factor in many of the full-scale fabrications that were subjected to PWHT.

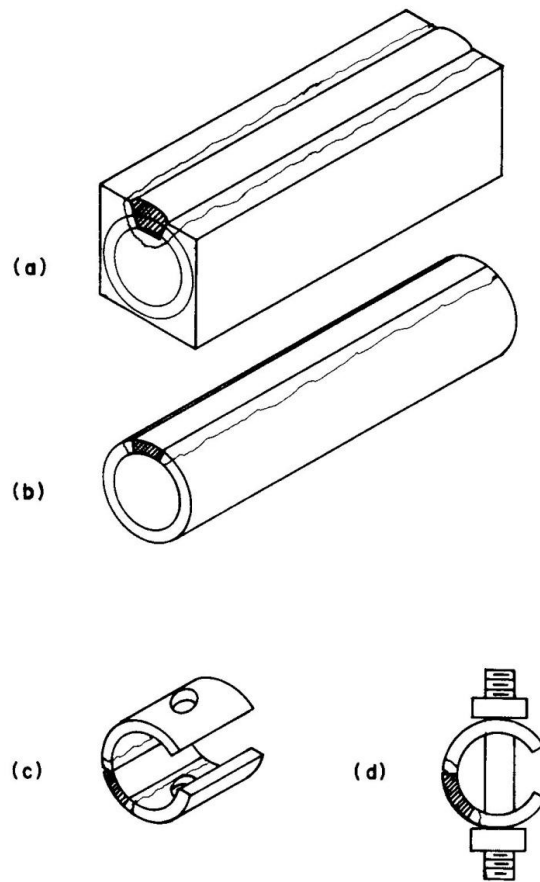
Several test methods evolved for the full range of considerations that needed to be considered. A spiral notch method with the test sample oriented across the weld deposit, base metal HAZ and base metal was conceived and utilized effectively to isolate the most sensitive weld region [9]. The notch was of the type employed with the Implant Test and the temperature-time-stress exposure paralleled the Gleeble test methodology. In a major study involving 20 heats of 1- $\frac{1}{4}$ Cr- $\frac{1}{2}$ Mo material a larger scale test method uses the deposition of a weld with welding parameters appropriate to actual weld fabrications conditions was conceived and effectively used to develop a chemistry related factor for reheat cracking potential [15]. This test, called the PREVIEW method (Petroleum Refinery Vessel Evaluation of Weldability), allowed for natural stress relaxation during a PWHT exposure and thus duplicated more closely the behavior of actual weldments. The results of the PREVIEW method of assessment closely paralleled the standard Gleeble method and other test methods [15].

In the evaluation of the Cr-Mo-V steels a notched C-Ring testing methodology (based on the ASTM Stress Corrosion Cracking Standard G-

38) was developed for the prediction of reheat cracking in the weld HAZ in the mid-to-late 1980's, in conjunction with US Department of Energy efforts to consider alloys which optimized the creep properties of vessels and tubing for advanced steam power applications [8, 9]. This notched C-Ring reheat cracking evaluation method was also extended to the Cr-Mo-V (22V) materials that were under development for pressure vessels in hydrogen service.

The concept behind the adoption of a notched C-Ring geometry for reheat cracking assessment was to utilize a proven methodology, wherein the effect of stress and material characteristics could be evaluated as to potential cracking incidents in welded fabrication. The extensive foregoing studies clearly showed the need for a discontinuity (physical or metallurgical) or defect in a weld, acting as a stress raiser to initiate a crack in the base metal HAZ. Thus, a notch could be incorporated with a stressed C-Ring to mimic the requirement of a stress raiser (amplifier). A notched and stressed C-Ring could be heat treated to duplicate weld PWHT conditions. Further, by employing a stressing bolt, which was of matching composition to the material being tested, the relaxation of stresses (stress reduction), accompanying PWHT also could be accommodated.

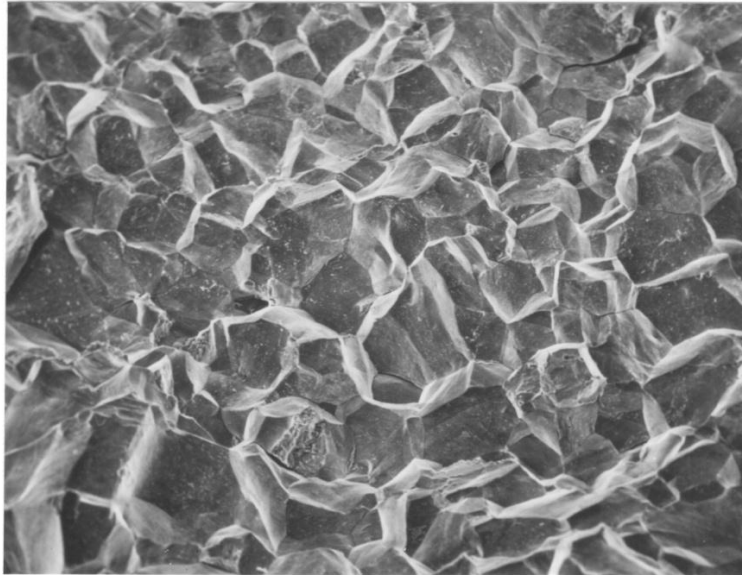
Initially, the notched C-Ring was employed to determine base metal HAZ reheat cracking sensitivity of structural steels because the filler metals generally were not the same composition as the base metal and yet achieved the same strength (thus only the base metal would be sensitive to reheat cracking). Figures 5 and 6 present the methodology for utilization of a notched C-Ring to characterize the coarse-grained base metal HAZ sensitivity to reheat cracking. The results of notched C-Ring testing of the weld HAZ exactly paralleled the response that was achieved using the Gleeble Test Simulated HAZ Method introduced by Vinckier and Pense [33].



**Figure 5. Successive steps for production of base metal HAZ C-Ring specimens. (a) square bar with weld filled groove, (b) tube machined from square bar stock, (c) portion of the tube notched in the heat affected zone with holes drilled through the ring**



A



B

**Figure 6. Cr-Mo-V base metal HAZ notched C-Ring. 1150°F (621°C) 100Ksi (690 MPa). A) OLM 100X, B) SEM 200X, Noren's Reagent.**



However, with the considerations for elevated temperature-time dependent (creep) use in hydrogen environments the filler metals (weld deposits) were tailored to closely match the composition of the base material and thus the weld deposit would be expected to behave in a manner which would reflect a similar sensitivity to reheat cracking in the coarse-grained regions. Therefore, it was relatively straightforward to adapt the notched C-Ring methodology to 22V SAW weld deposits, which closely matched the base metal chemistry as far as the major and minor alloying elements are considered.

### **III. Preliminary Study of Fracture Surface Morphology in 22V.**

A study was undertaken in response to several incidents that have been reported for SAW weld deposit cracking in 2-¼Cr-1Mo-V (22V) pressure vessels [4]. This study specifically involves the characterization of the crack surface morphology, by Scanning Electron Microscopy (SEM); of reheat cracks and hydrogen assisted cracks so that the crack type can be clearly differentiated. The study utilized the Notched C-Ring Reheat Cracking Test (NCRRCT) that is currently in development as well as a Modified Hydrogen Sensitivity Cracking Method which was developed in the Materials Joining Group at The University of Tennessee. The results clearly show distinct differences in crack surface morphologies for the two

types of cracking and these unique features permit the unequivocal differentiation of the cracking mode. Thus, researchers will be able to bench mark their findings with the crack surface images presented in this work. The research will also enable investigators to positively classify weld deposit cracking in the 22V alloy system and aid in the further development of the Notched C-Ring Reheat Cracking Test.

Reheat cracking theory has been discussed previously in this work. The following will provide a brief description of hydrogen assisted cracking (HAC) to aid in understanding the results of this preliminary study.

Hydrogen within the weld deposit can result in crack formation only after the weld has cooled, sometimes after a significant amount of time. Hydrogen assisted cracking has been known to take place in Cr-Mo-V steels and is very similar in macroscopic appearance to reheat cracking. Though the appearance is similar, HAC results from different factors and must be mitigated in different ways.

HAC are caused, very simply, by the incorporation of hydrogen into a weld deposit. There are a number of ways this can happen. Hydrogen may be present in the atmosphere, produced in the arc by a wet or damp flux, or present due to operating conditions [9]. When a weld is exposed to hydrogen, the liquid weld pool absorbs the hydrogen. The solid solubility of

hydrogen decreases sharply at the freezing point and again at the austenite/bainite/martensite/ferrite transformation temperature. These processes allow diffusible hydrogen to coalesce, eventually leading to crack formation if positive steps are not taken.

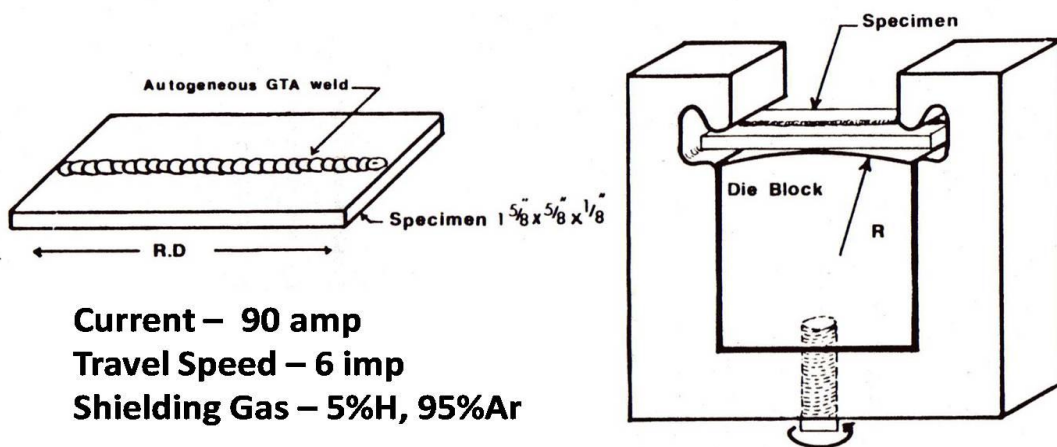
As a rule, the possibility of HAC increases with the amount of bainite/martensite present in the HAZ or weld deposit. The bainite/martensite amount, in a rapidly cooled weld, is dependent on composition, maximum temperature reached, and cooling rates. These several factors result in four main considerations many of which are identical to reheat cracking [70]:

- i. The composition of the steel.
- ii. The welding conditions that influence hydrogen presence.
- iii. The weld cooling rates that govern the formation of transformation products.
- iv. Residual stresses created upon welding.

Hydrogen facilitates crack formation as it attempts to diffuse out of the weld fusion zone. As a function of time, hydrogen diffuses through the weld until it finds a favorable trapping site. The time factor is related to the hydrogen diffusion rate on the material. As more hydrogen collects at a

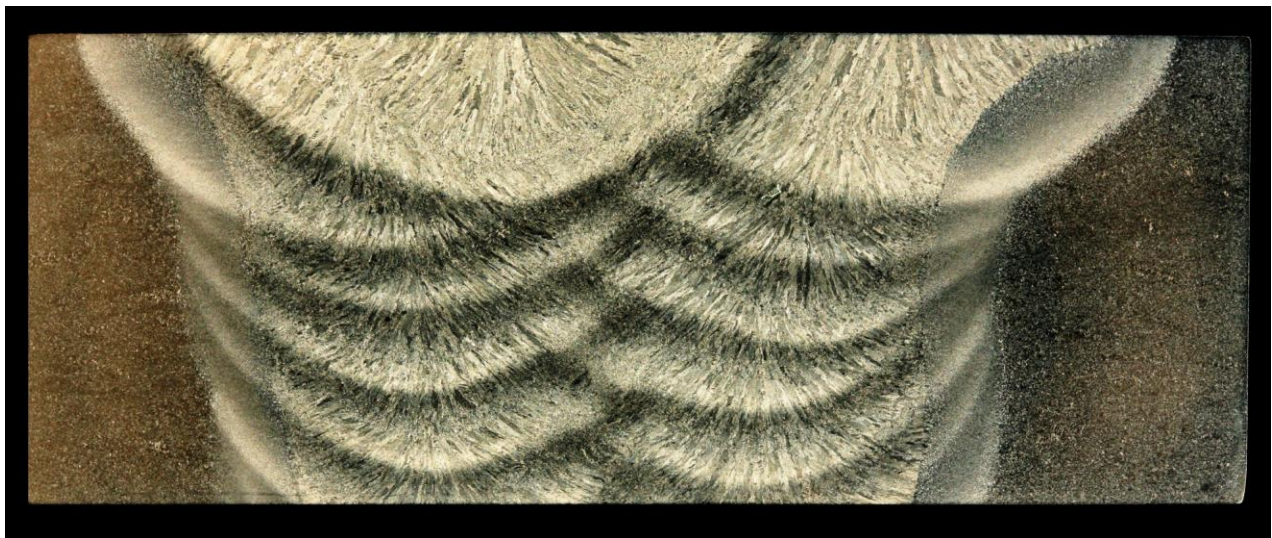
suitable site (such as an interface) it may lower grain boundary separation energy and thus facilitate crack formation [9].

22V weld deposits were subject to potential hydrogen cracking by autogenously GTA welding a small coupon extracted from a SAW weld deposit, using 5% hydrogen 95% argon shielding gas. This procedure saturates the GTA welded deposit with hydrogen on the order of 5-10 ppm. Within 5 minutes, subsequent to weld deposition, the sample is strained in the fixture shown at the right in Figure 7. For this study 6% strain was utilized (however, the strain can be varied simply by changing the radius of the die block). The samples developed delayed hydrogen cracks in the autogenously GTA weld region within 1 hour after straining. The sample is then Cryo-Cracked in liquid nitrogen to expose the hydrogen induced crack surfaces for SEM examination.



**Figure 7. UT- Modified hydrogen sensitivity test specimen is shown at the left and test fixture at right**

Two narrow groove 22V SAW were used in the evaluation of Notched C-Ring Reheat Cracking Test and modified hydrogen sensitivity cracking (UTMHST) in terms of the crack surface morphology. A weld cross-section of a representative narrow groove SAW weld is shown macro-graphically from one of the weldments evaluated in Figure 8.

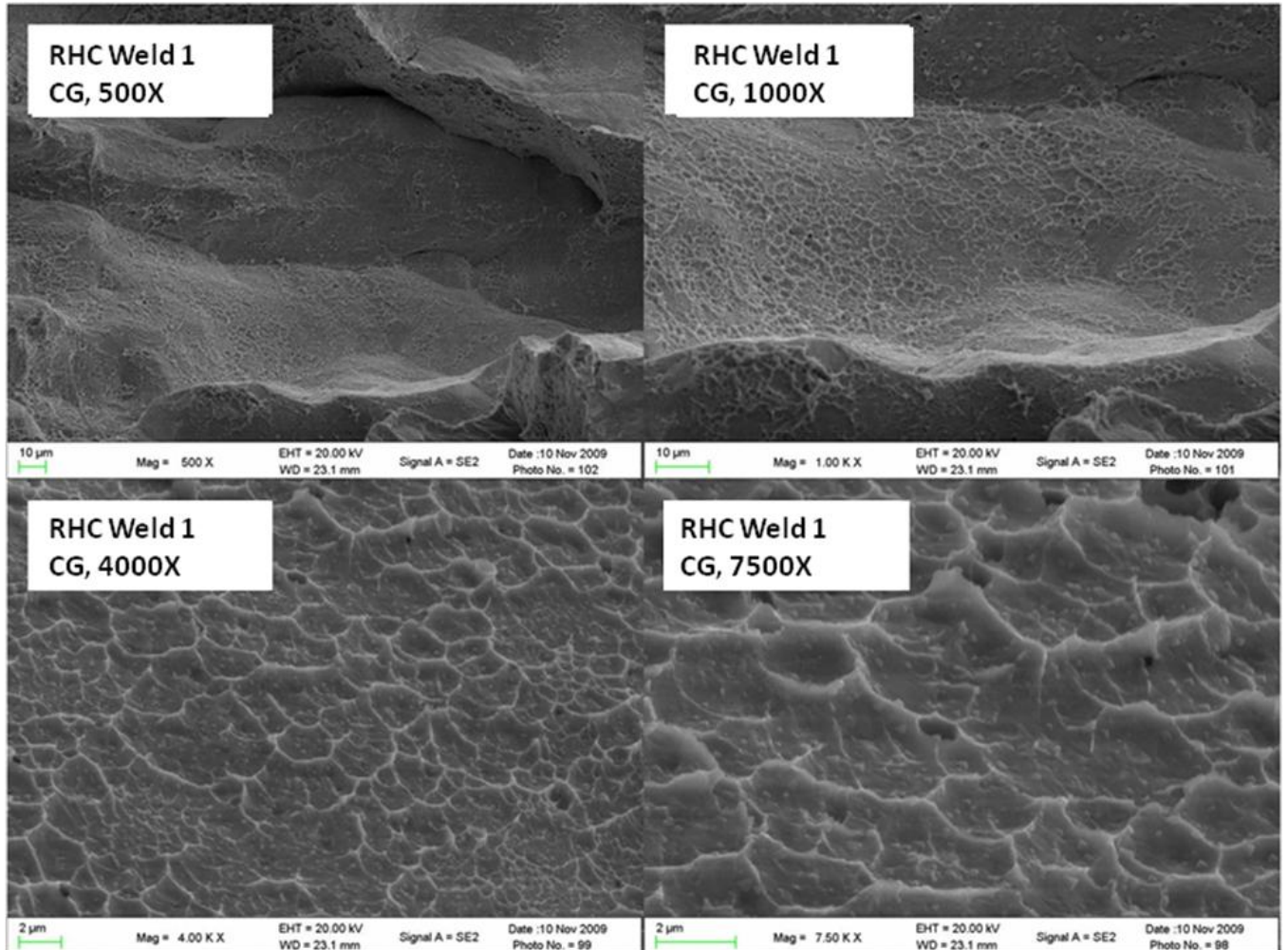


**Figure 8. Weld cross-section of narrow groove SAW weld used in This study, Noren's Reagent submerge for 8 sec, 6X [71].**

### **Reheat Cracking in 22V Weld Deposit**

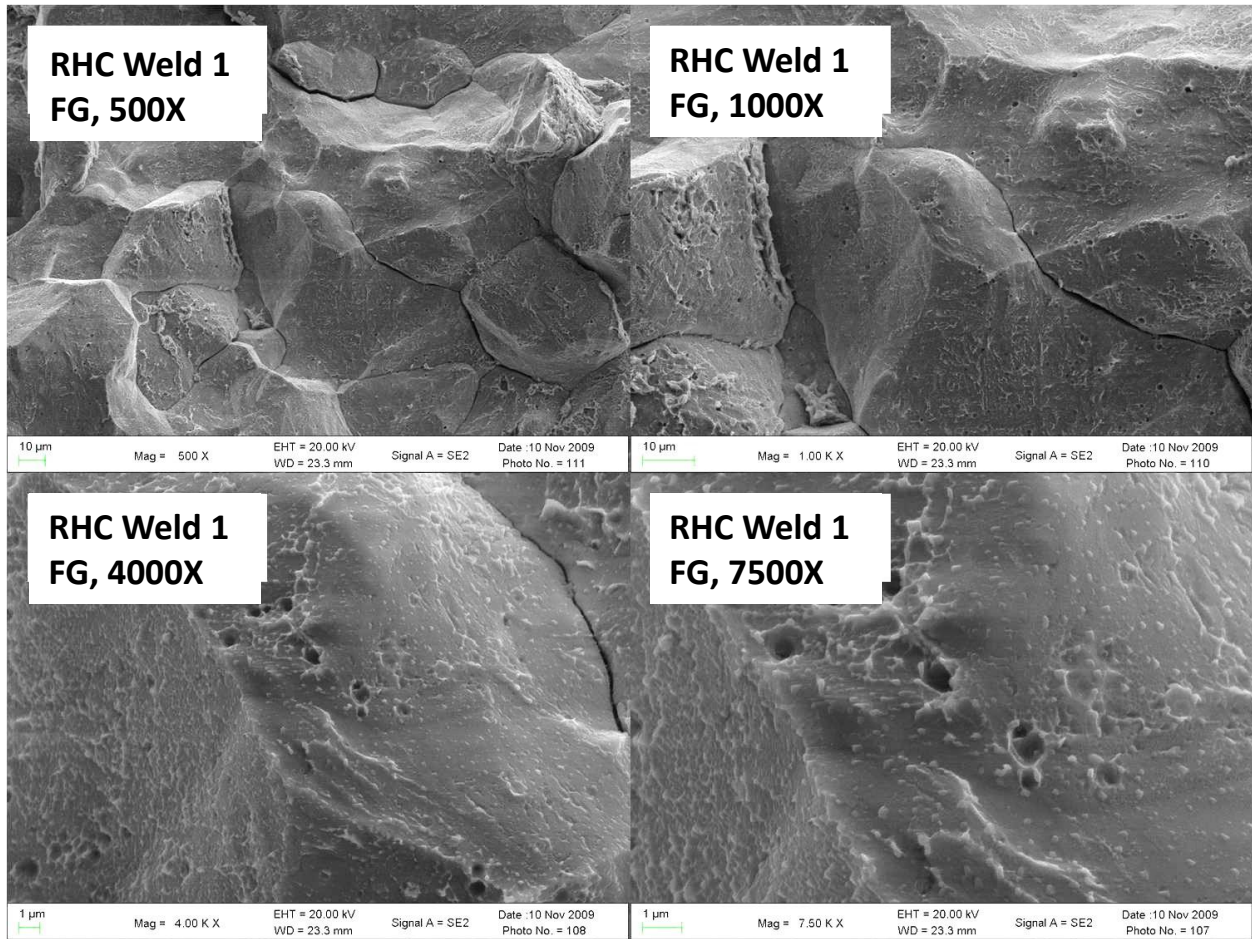
It has been previously pointed out that, for the C-Ring, the notch traverses several weld layers. Thus, the cracking can occur in all regions of the weld deposit (coarse-grained and fine grained regions). Figure 9 shows reheat crack surface morphology in the coarse-grained region of a 22V Weld at magnifications from 500X to 7500X. At the lower

magnifications of 500 and 1000X it is clear that the reheat crack morphology is intergranular in nature, while at the 4000X to 7500X magnification the occurrence of shallow dimples (~¼um in depth and ~2um wide) containing particulates is evident.



**Figure 9. SEM of the reheat crack surfaces of the coarse grained region of the 22V SAW weld 1 deposit. Note the Intergranular macro-morphology and the occurrence of shallow dimples with particles in the dimple craters.**

Figure 11 presents the surface morphology in the fine-grained region of a weld deposit over the same range of magnifications. It is clear that, macroscopically, the crack morphology is intergranular. However, the higher magnification images of the grain surfaces show a different micro-morphology as compared to the coarse-grained region with the general absence of the shallow dimples revealed in the coarse-grained region. In the case of the fine-grained region, the shallow dimples are a minor feature. This suggests that a slightly different mechanism exists for the fine-grained region and it may be that of a propagation mode in the fine-grained region rather than the initiation mode of reheat crack formation in the coarse-grained region, with shallow dimples, which are a definitive characteristic of the cracks in the coarse-grained region.

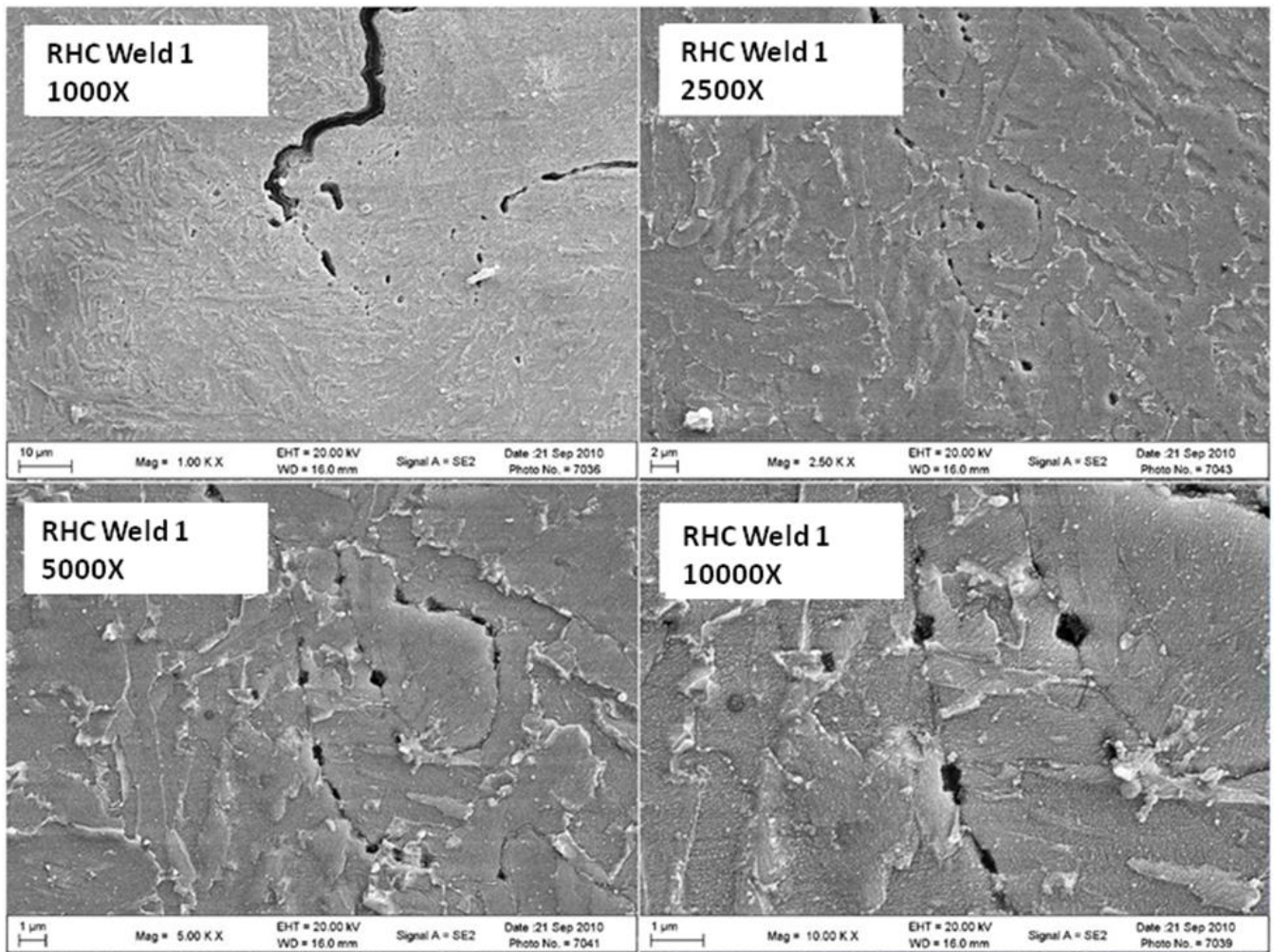


**Figure 10. SEM of the reheat crack surfaces of the fine grained region of the 22V SAW weld 1 deposit. note the intergranular macro-morphology.**

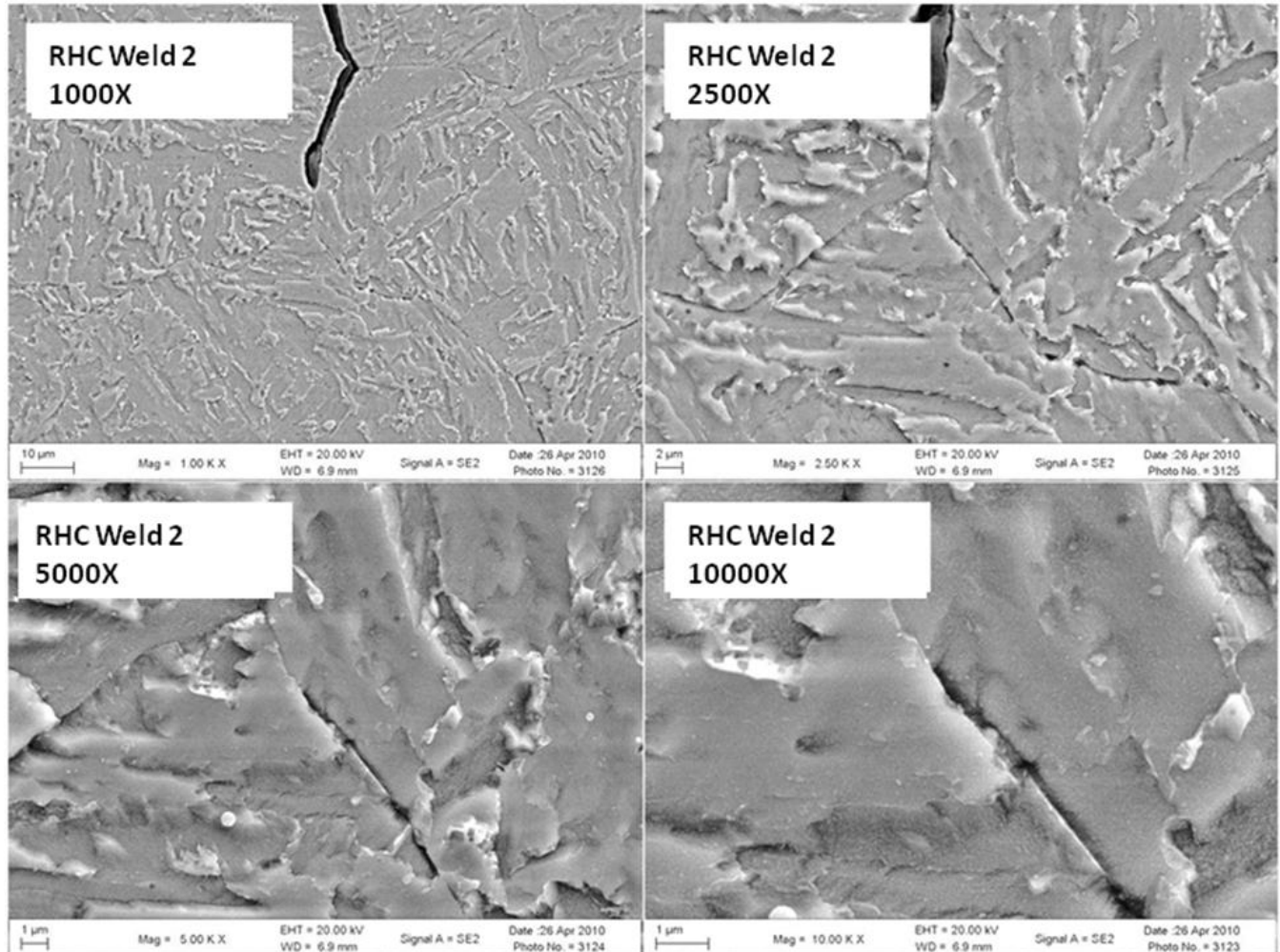
To further characterize the nature of the reheat cracks in both the weld deposits, metallographic samples excised perpendicular to the crack and transverse to the notch, were polished and etched with 10% Ammonium Persulfate. These samples were examined using the SEM. The respective series weld deposits are shown in Figures 11 and 12 at magnifications of 500 to 1000X. Clear evidence for cavitation/void



formation precedes the full opening of the crack surfaces as defined in Figures 11 and 12. Evidence for this cavitation/voiding was also noted in the SEM imaging of the crack surfaces (see particularly Figures 9 and 10). This type of cavitation/voiding indicates that a creep mechanism might be a part of the mode of reheat crack formation.



**Figure 11. SEM micrographs of the polished and etched surface perpendicular to the 22V SAW weld 1 deposit. note the cavitation/voids just ahead of the crack tip**

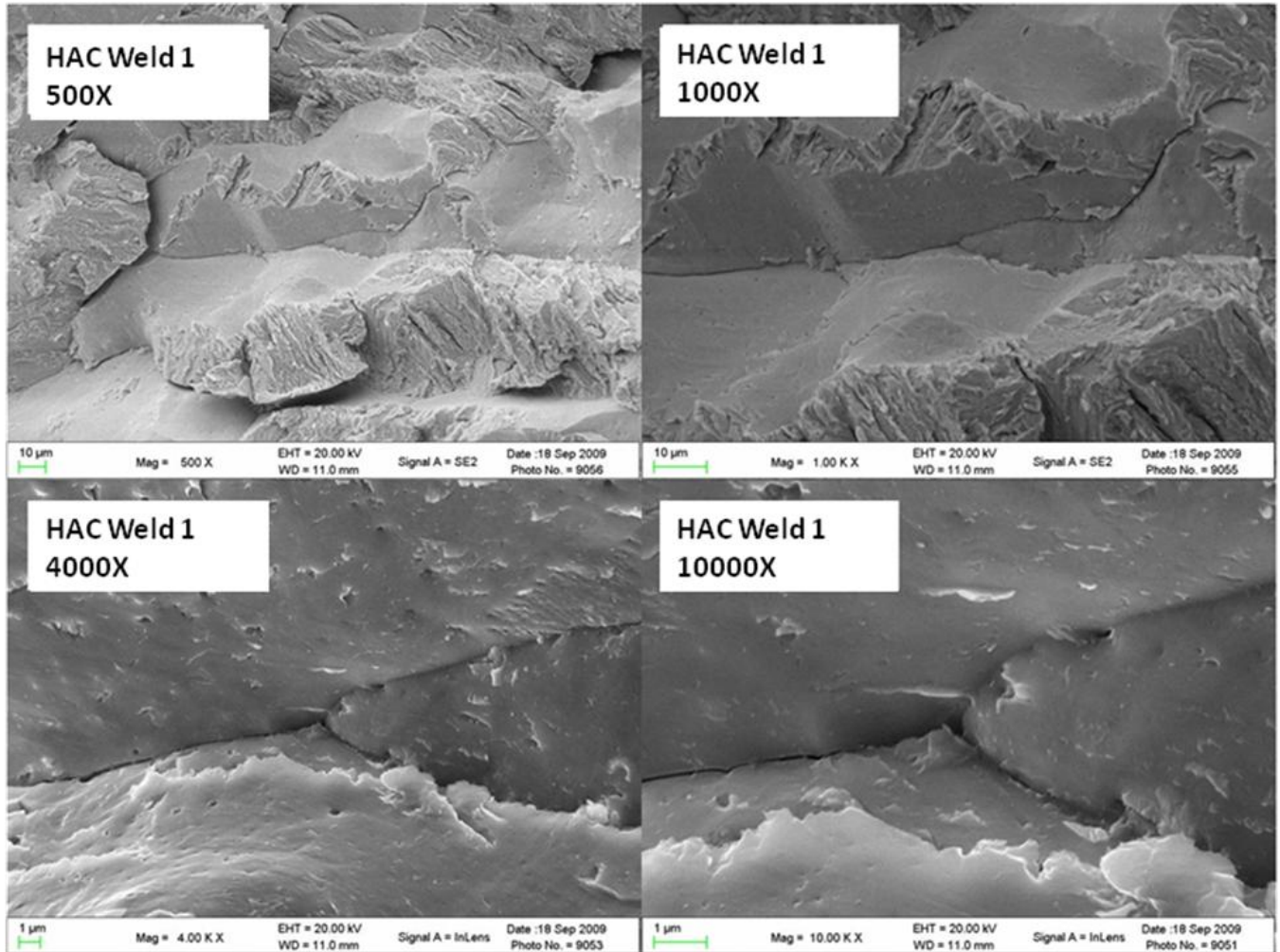


**Figure 12. SEM micrographs of the RHC polished and etched surface perpendicular to the notch in the 22V SAW weld 2 deposit. Note the cavitation/voids just ahead of the tip.**

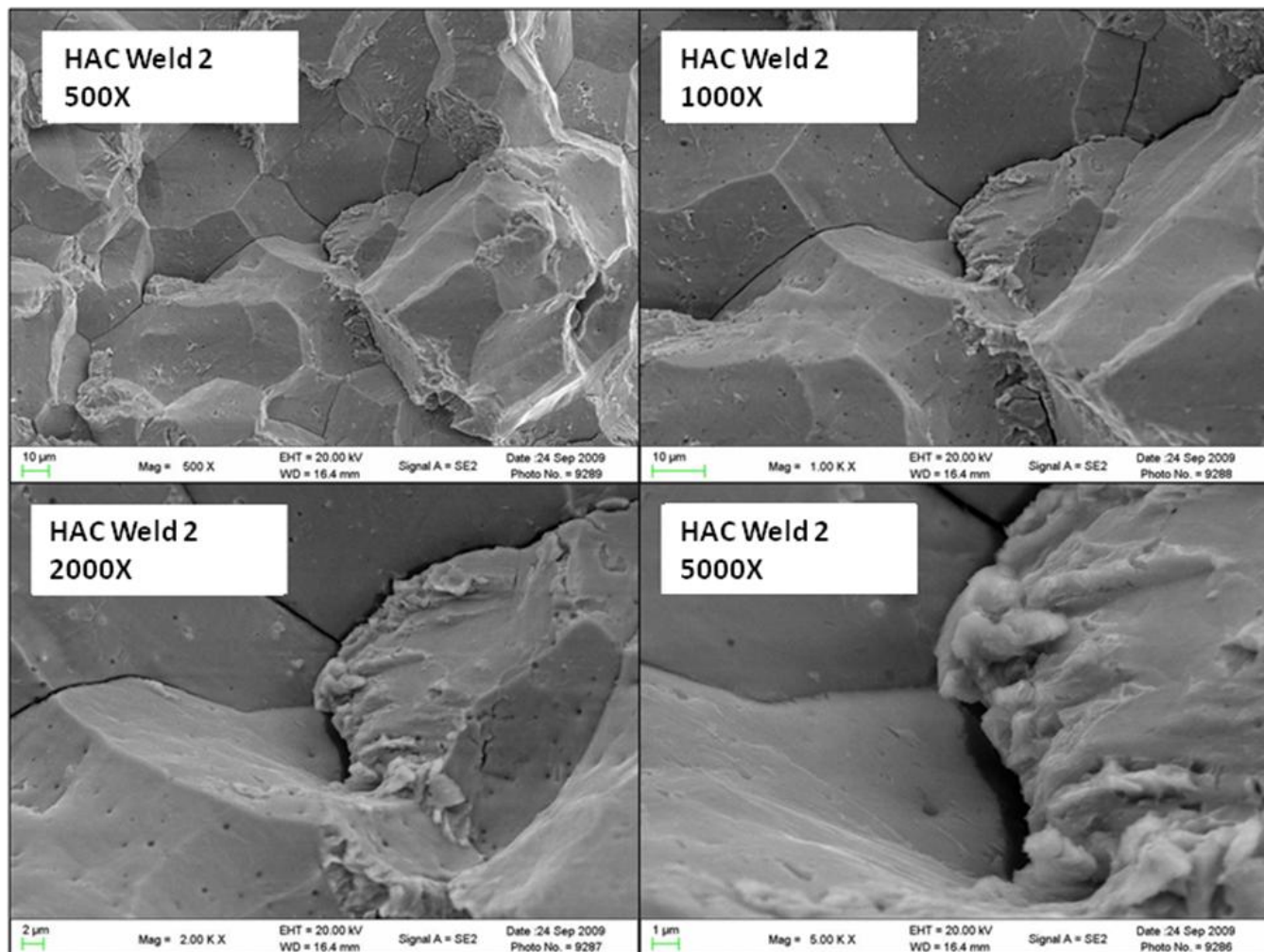
### **Hydrogen Assisted Cracking in 22V Weld Deposits**

Hydrogen assisted cracking was produced in an Autogeneous GTA weld in the 22V SAW deposit for 2 weld series by means of the University of Tennessee Modified Hydrogen Sensitivity Test (UTMHST) as previously described. The delayed hydrogen assisted cracks generally formed in and transverse to the GTA weld deposits. The full extent of cracking was

complete after an hour delay period subsequent to straining. Figures 13 and 14 show the results for the Weld 1 and Weld 2 series SAW deposits that were hydrogen cracked in the autogeneous GTA weld fusion zone over the magnification range of 500 to 10,000X. Both materials show identical crack surface morphologies, principally with a macroscopic intergranular crack nature. The grain faces produced by hydrogen assisted cracking are generally featureless, smooth and void free, with a few tongues. When the crack progresses across a grain a quasi-cleavage mode of separation is observed.



**Figure 13. SEM of the HAC surfaces in GTAW weld deposit of the 22V SAW weld 1 deposit. Note the Intergranular macro-morphology with transgranular crack propagation revealing a quasi-cleavage morphology.**

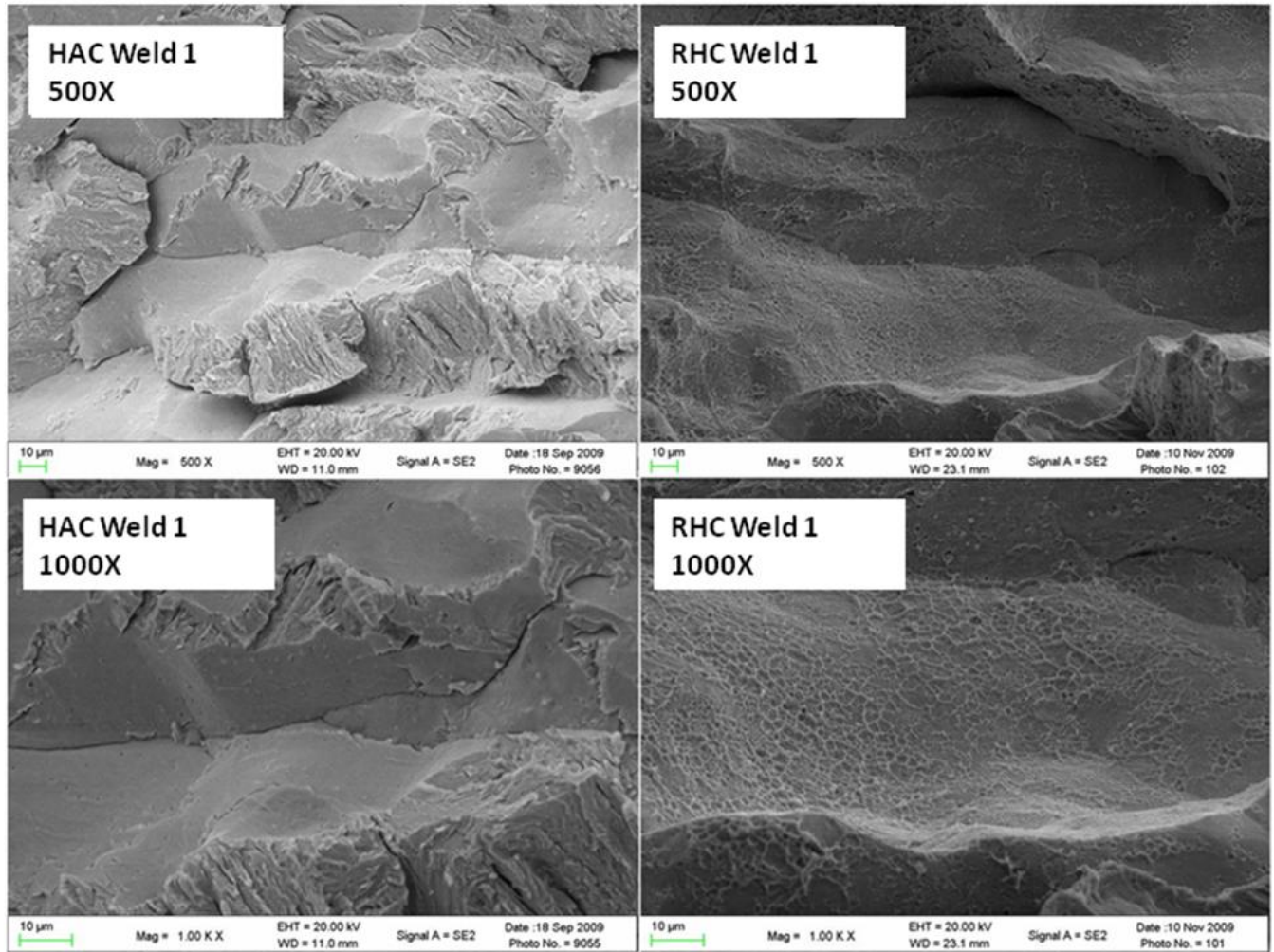


**Figure 14. SEM of the HAC surfaces in the GTAW weld deposit of the 22V SAW weld 2 deposit. Note the intergranular macro-morphology with the transgranular crack propagation revealing a quasi cleavage morphology.**

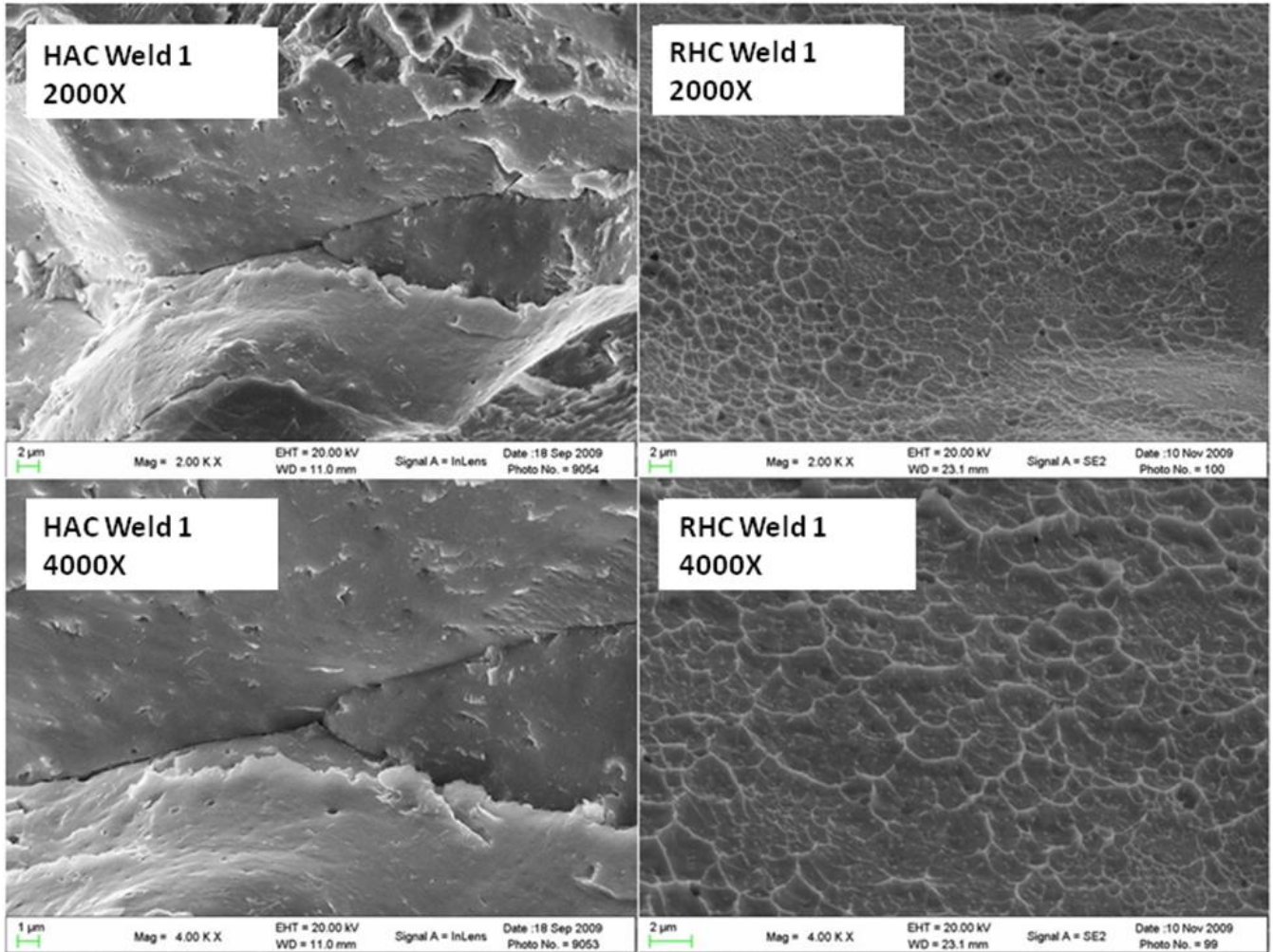
### **Comparison of Reheat and Hydrogen Assisted Crack Morphologies**

In order to more easily compare the crack surface morphology for the reheat cracks and hydrogen assisted cracks in the 22V deposits, companion SEM crack surface images are presented in a series of figures (Figures 15-20) at magnifications of 100 to 7500X. The intergranular nature of the cracks is clearly revealed at the low magnifications. However, definitive differences in appearance become evident at magnifications

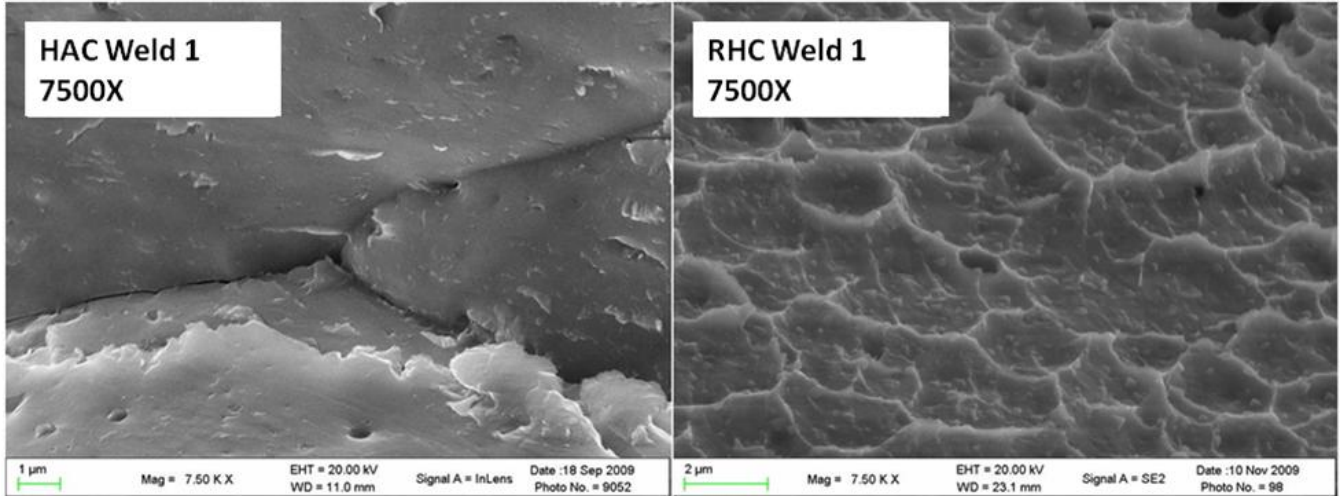
above 1000X. These comparison SEM crack surface images were discussed in detail earlier but it should be pointed out again that the reheat cracks clearly show evidence of shallow dimples with carbides present within the dimples and voiding/cavitation whereas the hydrogen assisted cracks show none of this type of morphological evidence of the higher temperature crack formation.



**Figure 15. SEM comparison of the HAC and RHC surfaces in the weld fusion zone of the 22V SAW weld 1 deposit. Note the intergranular macro-morphology for both crack types. HAC shows smooth grain faces, while reheat cracks show shallow dimples with particles in the dimple craters.**

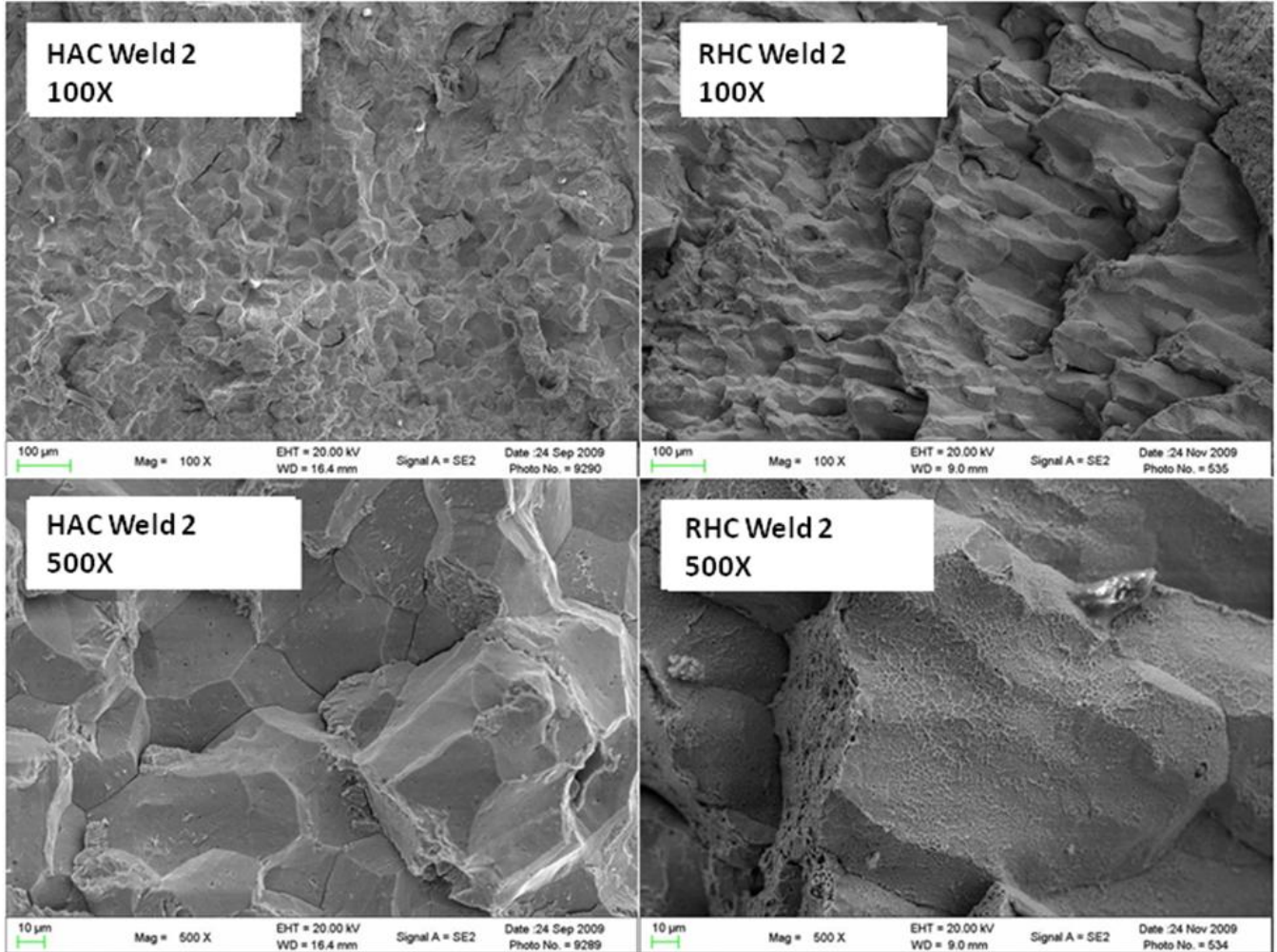


**Figure 16. SEM comparison of the HAC and RHC surfaces in the weld fusion zone of the 22V SAW weld 1 deposit. Note the intergranular macro-morphology for both crack types. HAC show smooth grain faces, while reheat cracks show shallow dimples with particles in the dimple craters.**

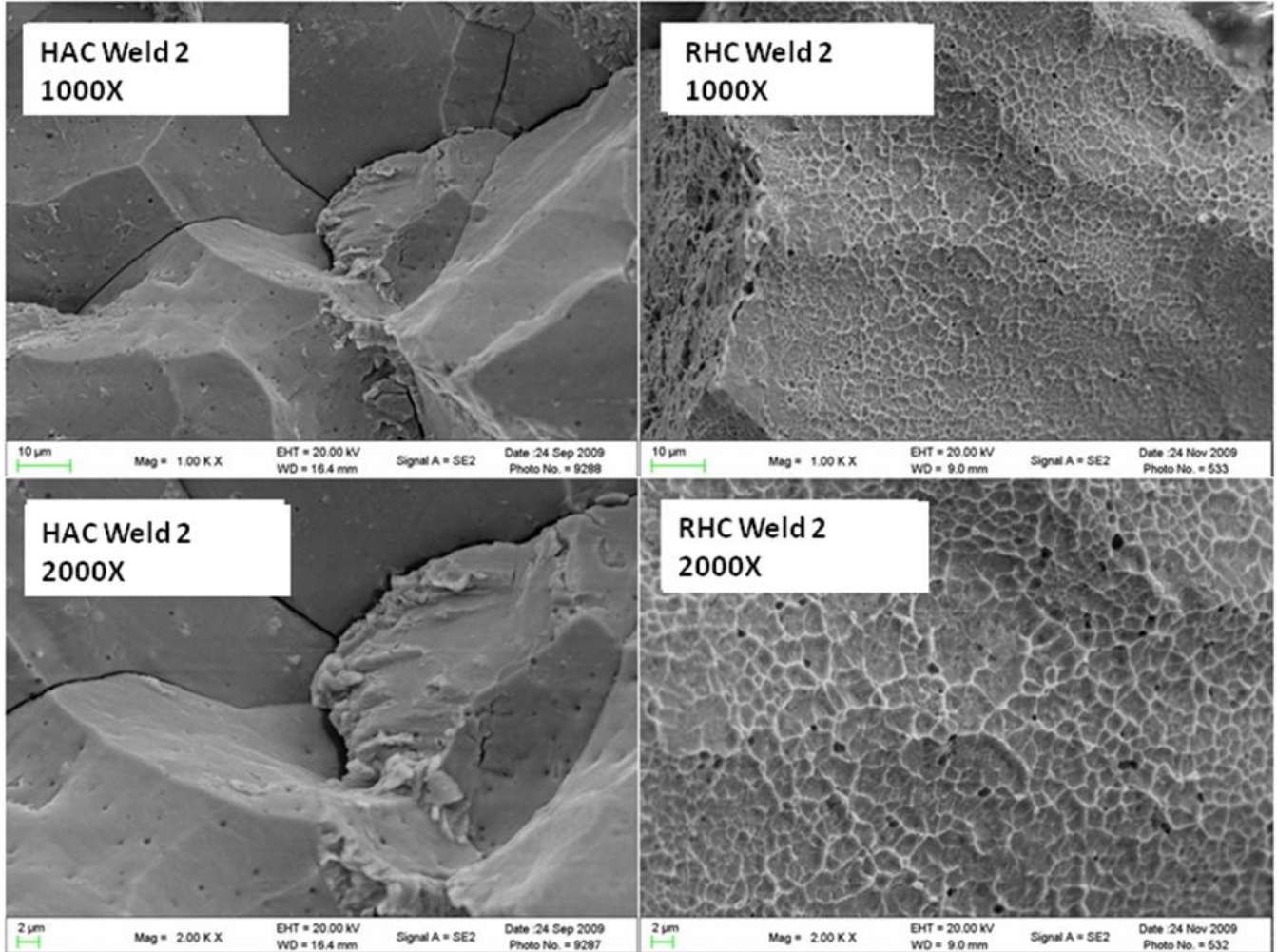


**Figure 17. SEM comparison of the HAC and RHC surfaces in the weld fusion zone of the 22V SAW weld 1 deposit. HAC shows smooth grain faces, while reheat cracks show shallow dimples with particles in the dimple craters.**

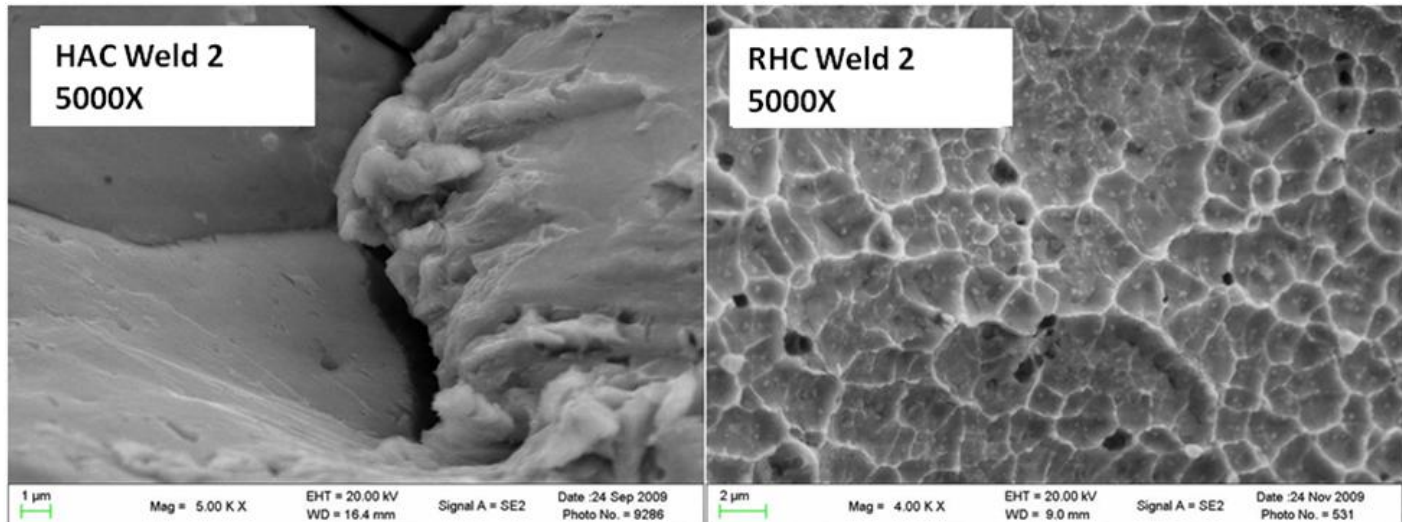




**Figure 18. SEM comparison of the HAC and RHC surfaces in the weld fusion zone of the 22V SAW weld 2 deposit. note the intergranular macro-morphology in both modes. HAC shows smooth grain faces, while reheat cracks show shallow dimples with particles in the dimple craters.**



**Figure 19. SEM comparison of the HAC and RHC surfaces in the weld fusion zone of the 22V SAW weld 2 deposit. Note the intergranular macro-morphology in both fracture modes. HAC shows smooth grain faces, while reheat cracks show shallow dimples with particles in the dimple craters.**



**Figure 20 SEM comparison of the HAC and RHC surfaces in the weld fusion zone of the 22V SAW weld 2 deposit. HAC show smooth grain faces, while reheat cracks show shallow dimples with particles in the dimple craters.**

### **Conclusions From the 22V Fractography Morphology Study**

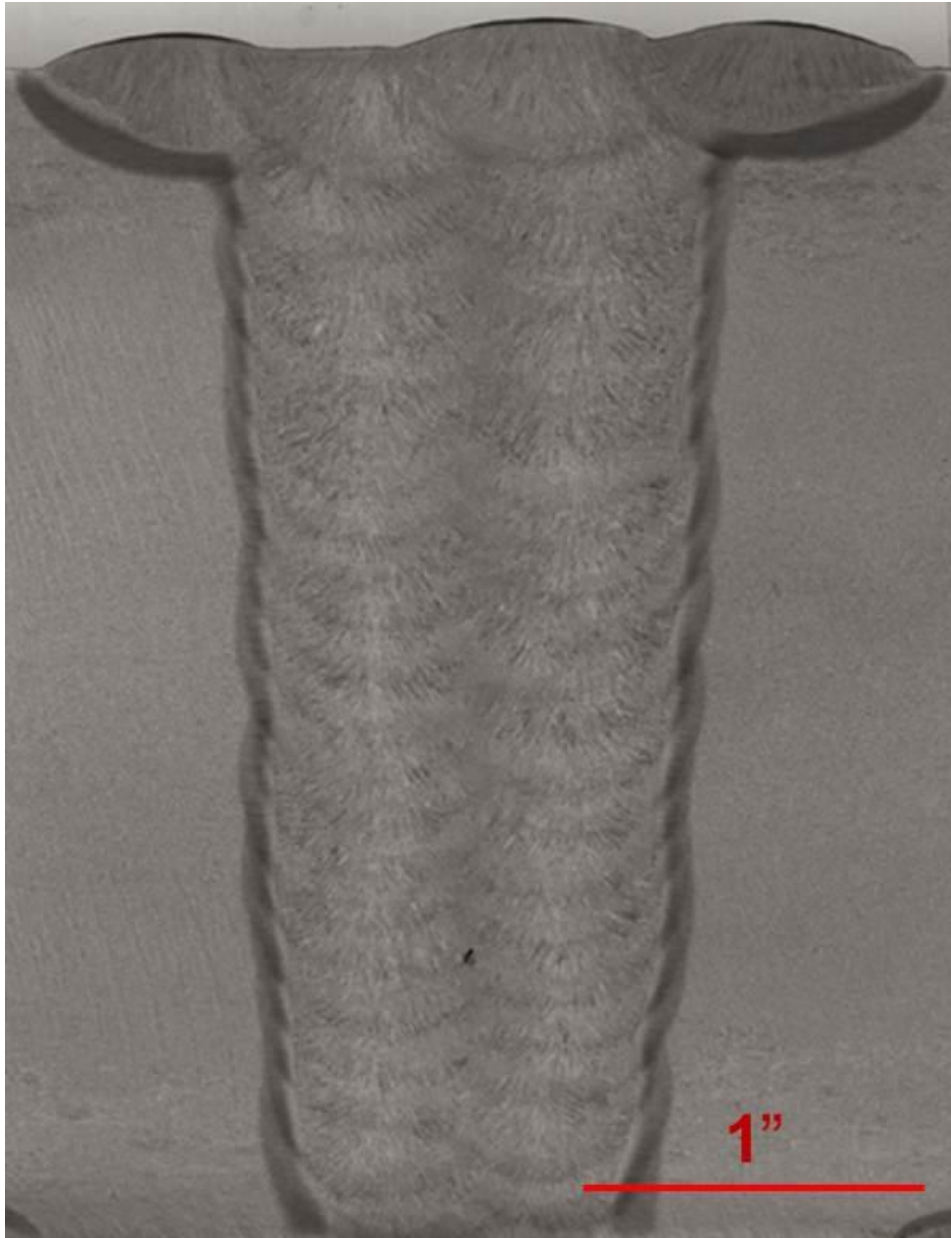
From the foregoing crack surface morphology discussions and illustrations it is evident that the reheat cracks and hydrogen assisted cracks are significantly different in appearance in 22V weld deposits. These appearance differences do not become evident until the crack surfaces are imaged at magnifications greater than 1000X. The importance of this lies in the fact that the type of cracking must be defined before any attempts to solve a particular “cracking problem” are undertaken. Furthermore, both types of cracks may be present in a 22V weldment wherein a hydrogen micro-crack may be a precursor to reheat cracking during PWHT. It is to be noted that previous studies have

revealed that a “trigger”, in the form of a preexisting weld discontinuity, whether it be internal or externally generated, usually precedes the initiation of a reheat crack. The presence of a residual stress, in and of itself, is generally not necessarily a sufficient cause for reheat crack formation.

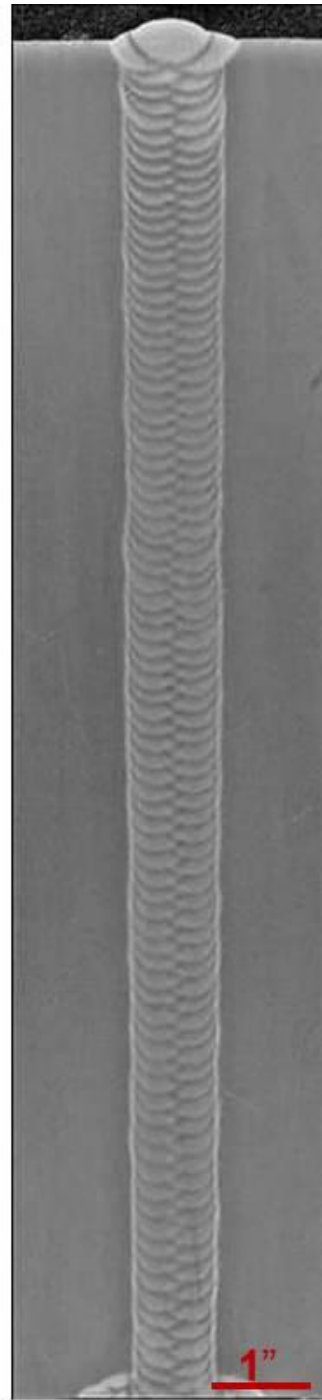
#### **IV. Experimental Procedures**

##### **Welds used in Study**

18 submerged arc weld deposits were utilized in the development of the NCRRCT, each selected to highlight different combinations of wire and flux, weld bead placement, and chemical composition. A typical test weld produced in the laboratory is shown in Figure 21. Two commercially produced welds are also provided for comparison in Figure 22.



**Figure 21. Typical 22V SAW weld produced for use in the development of the NCRRCT. Ammonium Persulfate etch, 2X.**



**Figure 22. Commercially fabricated welds used in the development of the NCRRCT. The weld on the left (C-22V-1) was extracted from a pressure vessel. The weld on the right (C-22V-2) was obtained from a fabricators procedure qualification coupon.**

## **Sample Extraction**

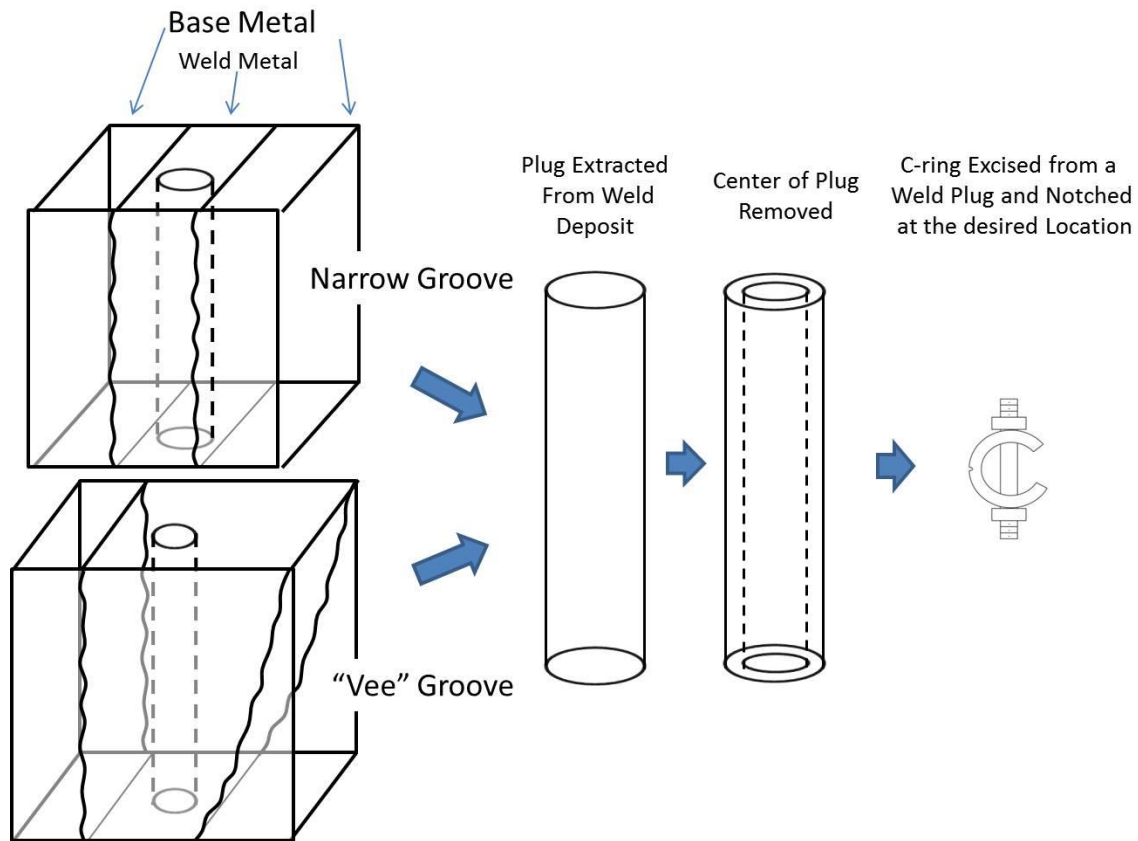
Using the work previously conducted at the University of Tennessee, a modified “C-Ring” test has been developed to satisfy the needs of industry for economically diagnosing reheat cracking sensitive materials before issues arise during the fabrication of heavy walled pressure vessels.

The original C-Ring test was developed to evaluate reheat cracking susceptibility in the coarse-grained base metal heat affected zone, and has been modified to allow testing of the reheat cracking susceptibility of 22V weld deposits (fusion zone). A modified C-Ring is shown in Figure 23. Figure 24 shows the extraction of the C-Ring from two different weld deposit geometries currently in use. After extraction from the weld, a notch is machined in to the ring in the proper location. In the case of the 22V weld deposits, the notch must traverse several weld beads and thus evaluate the fine-grained as well as the coarse-grained regions of the weld deposit for reheat cracking potential. The proper location of a notch in the weld deposit in the modified C-Ring is clearly shown in Figure 23.



**Figure 23. A notched C-Ring reheat cracking test specimen showing the correct placement of the notch traversing several overlapping weld bead passes in a narrow gap weld deposit, ~4X.**





**Figure 24. Schematic extraction of C-Ring samples from a narrow gap SAW butt weld and a general "Vee" groove butt weld geometry.**

### **Sample Production and Preparation**

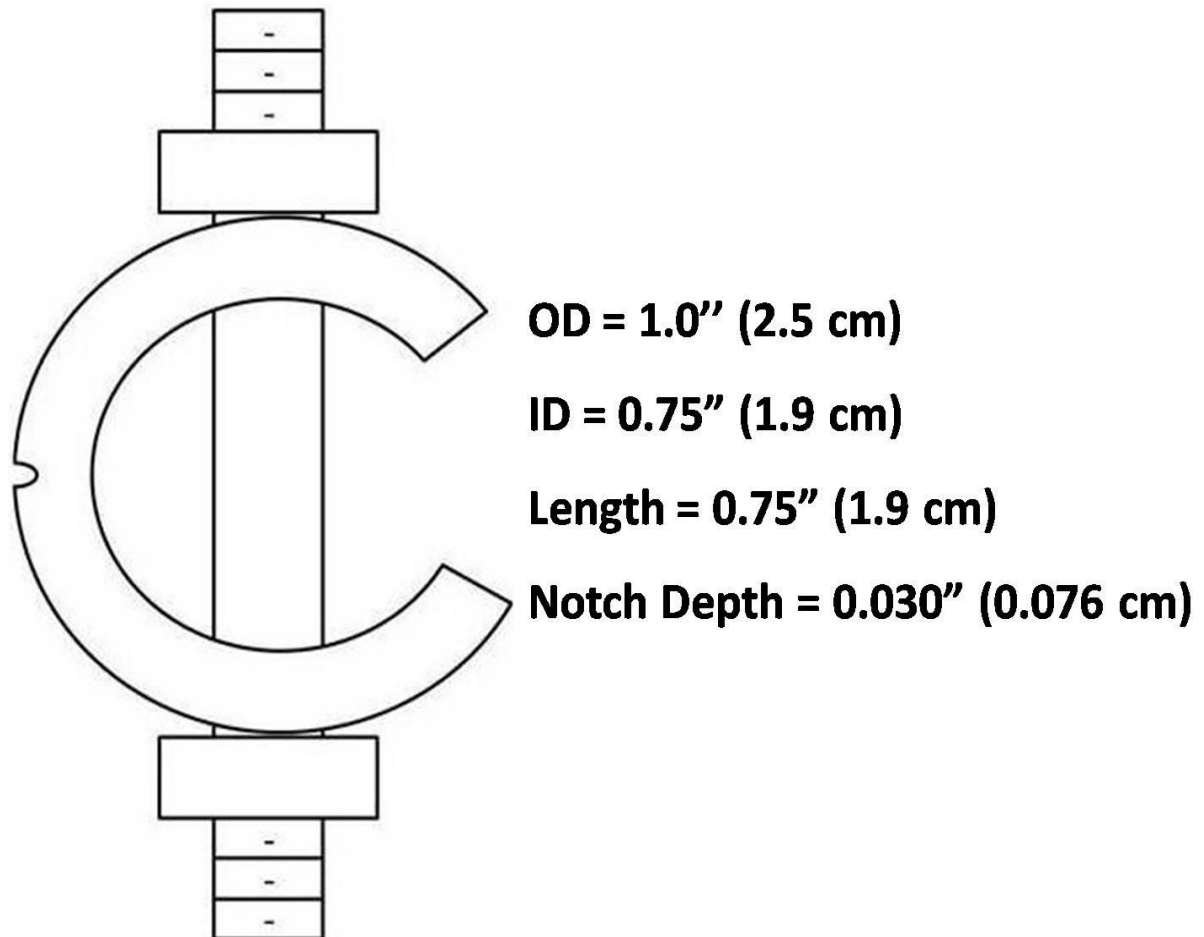
The following illustrations for extraction of a C-Ring for testing are based on both a narrow gap weld geometry with 2 SAW beads per layer, and also the more typical "Vee" groove weld geometry. A macrograph of a typical narrow gap weld cross-section is presented in Figure 25.



**Figure 25. Weld cross-section of narrow gap SAW in the as welded condition, Noren’s reagent, 6X [71].**

The cylindrical slug centered on the SAW narrow gap weld is extracted with its axis perpendicular to the weld surface whereas the “Vee” groove weldment provides greater latitude of placement within the weld deposit. Normal machining methods or EDM may be used to extract the cylindrical slug leading to the fabrication of the C-Ring. The slug is sized and bored into a cylindrical tube with the dimensions as shown in Figure 26: 1” (2.54 cm) OD and  $\frac{3}{4}$ ” (1.90 cm) ID with a length of  $\frac{3}{4}$ ” (1.90 cm). The length of the notched C-Ring is  $\frac{3}{4}$ ” (1.9 cm) and thus it will provide evaluation over a significant depth of weld deposit. For example, using a welding procedure that uses a 2 bead per layer sequence in narrow gap geometry, the notch will traverse at least 5 overlapping beads (see Figure 23). The etching of the C-Ring, as described above, reveals the weld bead sequence and

permits optimum determination of the notch position. For such a weld, the notch location will traverse both fine and coarse grained regions. This will allow concurrent reheat sensitivity analysis of both fine and coarse-grained weld deposit regions.



**Figure 26. Schematic of a C-Ring with dimensions. The notch is the same that is used in the standard impact test sample, but is limited to 0.030" (0.076 cm) in contrast to the 0.080" (0.2 cm) in the standard impact test specimen**

The Charpy notch geometry employed uses a depth of 0.030" (0.076 cm) as opposed to the 0.080" (0.20 cm) for the standard Charpy bar used for toughness testing. The deflection bolts (stressing bolts) are made from material with the same nominal composition as the test C-Ring. The C-Ring shown in Figure 23 has been etched with (10% Ammonium Persulfate) and shows the notch placed in the center of one of the weld bead stacks thus traversing several weld beads and overlapped regions. This notch location and its orientation ensures that all microstructures will be evaluated in a single sample. This etching technique can also be used after machining to verify the proper notch placement (traversing both fine and coarse-grained regions). Holes are drilled 90° to the notch location after the notching is complete and the back of the notched C-Ring is cut away to allow for deflection (stressing). The deflection needed to stress the notched C-Ring to a given Level is calculated from the equation given in ASTM G-38.

$$\Delta = \frac{(f\pi D^2)}{4EtZ}$$

$\Delta$  = Deflection (in)

f = Force (psi)

D = Diameter (1" minus the notch depth)

E = Elastic Modulus (Pa)

t = Thickness (wall thickness in inches at notch root)

Z = Correction Factor (0.94, provided in ASTM G-38)

The stressed, notched C-Ring is thoroughly cleaned in acetone using ultrasonic agitation, and heat-treated (tested) in a manner similar to a vessel PWHT. The heating conditions for the current testing procedure are designed to reach 1150°F (621°C) within 2-4 hours, followed by a 2 hour hold at 1150°F (621°C). After exposure at 1150°F (621°C) for 2 hours the C-Ring is removed from the furnace and air cooled. The test stress Levels are chosen to provide a crack-no-crack response. Testing can be conducted in air as well as in an inert atmosphere created by placing the notched C-Ring in a quartz tube and sealing after triple pumping and back filling with argon. The notched C-Ring is then cleaned and the root of the notch is examined for cracks. Sections can be cut for cross-sectional metallography if desired. The crack surface can be exposed for fractographic studies by fracturing the notched C-Ring through the notch at liquid nitrogen temperature.

### **Equipment**

The NCRRCT was designed to be a very simple test and thus it requires no special fixtures, stressing apparatus, or other proprietary instruments. The notched C-Ring sample is the stressing fixture onto-itself and thus requires no other (special) equipment. A furnace is required that is capable of reaching 1150°F (621°C) in 2-4 hours. It is also suggested that

the sample be wrapped in stainless steel foil to provide a cleaner surface for post-test analysis. Once the notched C-Ring has been heated and held for 2 hours, the only required instrumentation is a simple binocular stereo-zoom microscope (40X-50X) to examine and confirm the location, at the root of the notch, of any reheat cracks. Further evaluation may include cryo-cracking at liquid nitrogen temperature to open the cracked, notched C-Ring to more closely assess the degree of cracking, but this is not necessary in order to rank the sensitivity to reheat cracking.

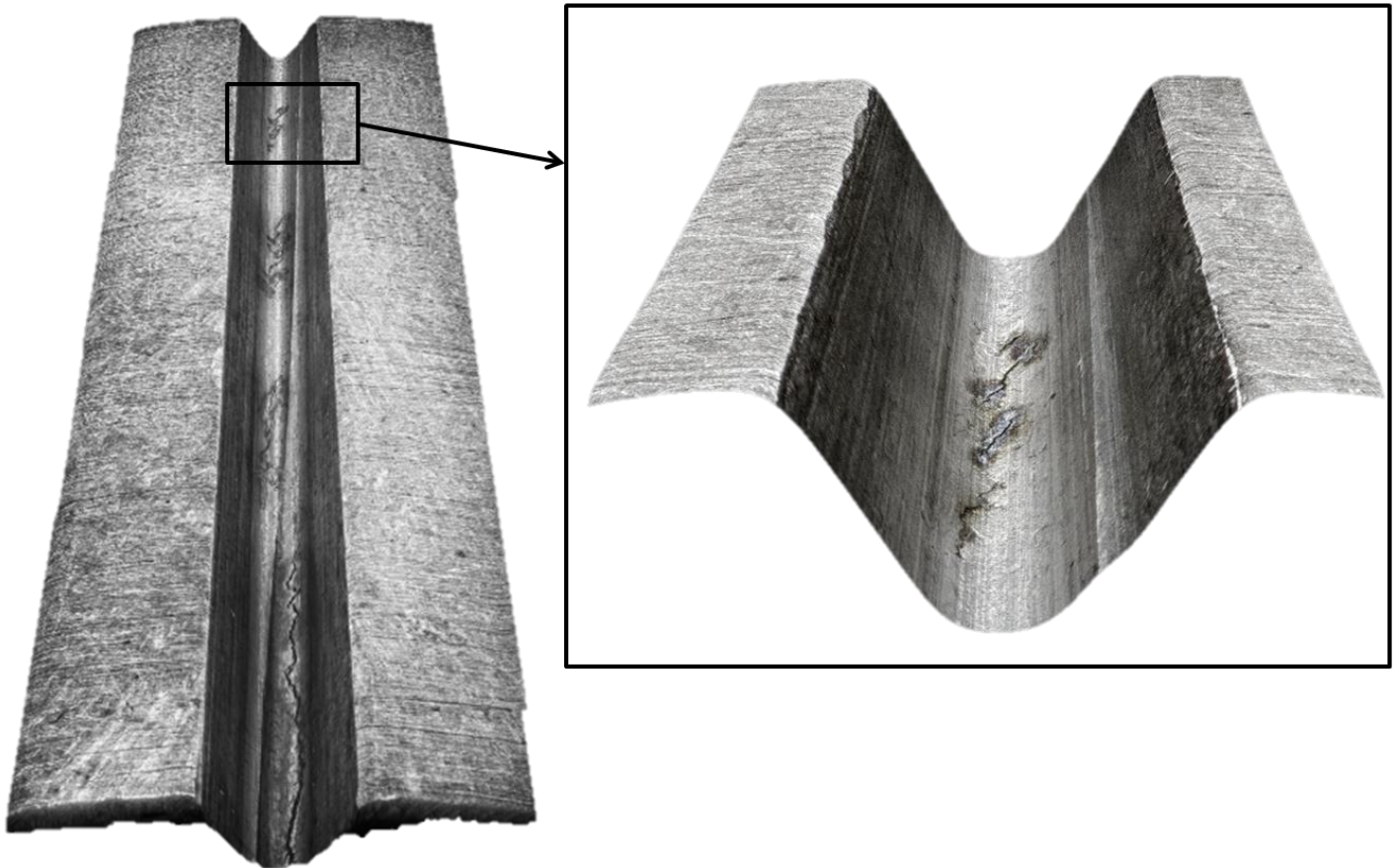
### **Using the NCCRCT to test for Reheat Cracking Susceptibility**

The notched and drilled C-Ring is loaded by hand with a stressing bolt (machined from the same material) to a known deflection which corresponds to a given stress. The suggested stress magnitudes are: 55Ksi (380MPa), 70Ksi (480MPa), 85Ksi 590(MPa) and 100Ksi (690MPa) and the corresponding deflection for each of these stresses, as calculated using ASTM G-38, is presented in Table 5. It is recommend that the 85Ksi (590MPa) stress be the first test Level allowing subsequent tests to be conducted at a higher or lower stress Level based on the response at 85Ksi (590Mpa). Testing is conducted according to the detailed protocol described in Appendix I. These test methods facilitate the correct sensitivity assessment of reheat cracking in the notched C-Ring 22V weld deposits.

**Table 5. Calculated notched C-Ring reheat cracking sample test deflections calculated using (ASTM G-38) and a wall thickness at the root of the notch**

Stress Magnitude	Deflection (inches)	Deflection (mm)
55Ksi (380MPa)	0.014	0.37
70Ksi (480MPa)	0.018	0.47
85Ksi (590MPa)	0.022	0.57
100Ksi (690MPa)	0.026	0.67

After exposure to the elevated temperatures an oxide will have formed on the notched C-Ring sample during elevated temperature, and it must be removed to facilitate cracking assessment. The tested C-Ring should be placed in a 50/50 Hydrochloric acid/water solution (with an organic inhibitor to prevent attack on the metal surface) to allow for removal of the oxidation that develops during thermal exposure. The HCl bath will quickly remove the oxidation left as a result of exposure in the furnace. A plastic bristle brush is recommended to assist in removing any excess scale/oxidation from the root of the notch. A binocular stereomicroscope, or similar device capable of magnifications 40-50X, is used to examine the root of the notch for the presence of reheat-cracks. Cracking at the root of a C-Ring notch is illustrated in Figure 25.



**Figure 27. A tested C-Ring after cleaning in a 50/50 hydrochloric acid/water solution showing a typical cracking at the root of the notch,6X and 50X.**

The NCRRCT is intended to be a pass/fail (Go-No Go) test as a function of test stress. The presence of a crack indicates a “fail” while no cracking is a “pass” at a given stress Level. The four stress levels are level



“1”-100Ksi (690MPa), Level “2”-85Ksi (590MPa), Level “3”-70Ksi (480MPa) and level “4”-55Ksi (380MPa).

Successive test are run to uniquely define the reheat crack sensitivity based on the crack/no-crack result. The 85Ksi stress (Level 2 ranking) is the recommended starting stress. If no crack is found at this stress Level, the next test would be run at 100Ksi (Level 1 ranking). Extensive testing showed that the 100Ksi stress should produce a crack in 22V weld deposits and a Level 1 ranking would be given to the weld deposit. If a crack is found at the 85Ksi stress Level, a new test would be run at the 70Ksi (Level 3 ranking). If no cracking occurred during testing at Level 3 the 22V weld deposit would receive a Level 2 ranking. If the weld deposit continues exhibit cracks at the 70Ksi stress, a new C-Ring would follow loaded to the 55Ksi stress (Level 4 ranking) and tested. If no cracking is noted at the 55Ksi stress a Level 3 (70Ksi) ranking would be given to the weld deposit. Only welds exhibiting cracks at the 55Ksi Level would be given a Level 4 ranking.

Cracking noted at the 70Ksi (480MPa) or 55Ksi (380MPa) stresses (Levels 3 & 4 respectively) indicates a significant sensitivity to reheat cracking. If the test indicates a crack at 85ksi (590MPa), level 2, the weld

deposit has only a minor sensitivity to reheat cracking and normal welding procedures will generally suffice. If cracking is only found at or above the 100ksi (690MPa) stress (level 1) virtually no sensitivity to reheat cracking exists in the weld deposit and all normal welding procedures will be satisfactory.

If it is desired to further analyze the degree of cracking at any Level, the notched C-Ring may be cooled to liquid nitrogen temperature and a hammer blow used to fracture the cold notched C-Ring revealing the reheat-crack surfaces. The fractured notched C-Ring pieces should be placed in methanol to warm them to room temperature followed by hot air drying in order to prevent condensation and possible oxidation of the fracture surface. Binocular stereo-zoom microscopy may then be used to confirm reheat cracking and the extent of the cracking. The presence of a reheat-crack in an air tested sample is readily indicated by a dark intergranular crack surface morphology in contrast to the shiny metallic transgranular cleavage of low temperature cryo-crack fracture. The extent of the cracking can also be noted in terms of depth and length (continuous or intermittent). This information may be used later to more clearly define the susceptibility of different microstructural regions in the weld deposit.

## **V. Results and Discussion**

As part of the determination of the utility of the NCRRCT for assessing reheat cracking sensitivity of Cr-Mo-V SAW weld deposits, a study has been completed using a total of 18 welds. All of The 18 welds were evaluated using the Notched C-Ring Cracking Test protocol described in Appendix I. All tests were conducted in the as-welded condition. The designation for the 16 laboratory-fabricated test welds begins with a “T”, while for the commercial fabrication welds a “C” designation is utilized. Seven welds evaluated were intentionally doped with lead, bismuth, antimony, or a combination of the three. These welds are identified by a “D” in the weld deposit designation. The reheat cracking sensitivity ranking for the 18 different weld deposits as determined by the NCRRCT is shown in Table 6.

**Table 6**

**Reheat Sensitivity Rankings of Cr-Mo steels Using the Notched C-Ring Reheat Cracking Test**  
 Entries show the lowest stress at which cracking occurs for 18 unique weld deposits  
 when held at 1150°F (621°C) for 2 hours.

100Ksi (690MPa)	85Ksi (590MPa)	70Ksi (480MPa)	55Ksi (380MPa)
Level 1	Level 2	Level 3	Level 4
<b>C-22V-1</b> <b>C-22V-2</b> <b>T-22V-40</b> <b>T-22V-41-D-Sb (43ppm)*</b> <b>T-STD (P22)-13</b> <b>T-STD (P22)-13-D-Pb (4.8ppm)</b>	<b>T-22V-41</b> <b>T-22V-42</b> <b>T-22V-72</b> <b>T-22V-73</b> <b>T-22V-47</b> <b>T-22V-48</b>	<b>T-22V-39</b> <b>T-22V-41-D-Pb (2.2ppm)+Bi</b> <b>(0.7ppm)+Sb(41ppm)</b> <b>T-22V-47-D-Pb (3.5ppm)</b> <b>T-22V-47-D-Pb (9.5ppm)</b>	<b>T-22V-41-D-Pb (3.0ppm)</b> <b>T-22V-41-D-Bi (2.2ppm)</b>

\*All non-doped welds contained <2.3ppm Pb, <0.2ppm Bi, and <11ppm Sb

\*T-22V-41-D-Sb did not crack after 2 hours at 100Ksi and is thus considered to exceed the level 1 category

T = Test Weld

C = Commercial Weld

D = Doped

A full chemical analysis encompassing 50 elements was conducted by our industry partner. A selected chemistry compilation for the 18 welds is provided in Table 7 . Low-level element analyses was conducted using the inductively coupled plasma mass spectrometry (ICP-MS) method and the normal level elements utilized the Optical Emission Spectroscopy (OES) method. Table 7 allows assessment of the potential effect of chemistry on the sensitivity Levels assigned to each weldment as shown in Table 6.

**Table 7. Selected Chemistry for 18 weld deposits used in study**

Selected Chemistry Compilation for 18 Welds Used in Weld Deposit C-Ring Testing										
Detection Method	C (wt%)	Cr (wt%)	Mo (wt%)	V (wt%)	Mn (wt%)	Si (wt%)	Ca (ppm)	Ti (ppm)	Al (ppm)	Cu (ppm)
T-22V-39	0.081	2.50	1.05	0.280	0.640	0.30	<5	21	91	600
T-22V-40	0.082	2.51	1.00	0.343	1.090	0.15	20	11	53	1200
T-22V-41	0.095	2.33	0.98	0.263	0.900	0.18	20	14	79	950
T-22V-42	0.100	2.36	0.98	0.271	0.860	0.16	10	13	89	920
T-22V-41-D-Pb	0.125	2.33	0.99	0.236	1.240	0.08	5	<1	21	932
T-22V-41-D-Bi	0.107	2.34	0.99	0.238	1.180	0.08	12	2	25	1027
T-22V-41-D-Sb	0.130	2.34	0.99	0.250	1.130	0.06	<5	<1	36	460
T-22V-41-D-Pb+Sb+Bi	0.070	2.33	0.99	0.240	1.260	0.07	<5	2	47	510
T-22V-72	0.091	2.30	1.04	0.260	0.76	0.09	27	17	64	630
T-22V-73	0.086	2.30	1.03	0.240	0.78	0.09	41	13	46	590
T-22V-47-D-Pb (3.5ppm)	0.093	2.19	0.96	0.260	0.81	0.10	21	14	66	650
T-22V-47-D-Pb (9.5ppm)	0.086	2.30	1.03	0.250	0.80	0.09	54	10	47	540
T-STD(P22)-13	0.100	2.37	1.04	0.008	0.74	0.15	<5	14	100	1800
T-STD(P22)-13-D-Pb	0.110	2.36	1.02	0.005	0.75	0.15	<5	13	94	1800
T-22V-47	0.086	2.28	0.98	0.227	0.79	0.08	6	<1	49	455
T-22V-48	0.086	2.28	0.99	0.227	0.81	0.09	22	<1	46	405
C-22V-1	0.083	2.51	1.07	0.340	1.190	0.17	<5	5	50	1100
C-22V-2	0.126	2.48	1.05	0.230	0.980	0.11	<5	11	44	690

Selected Chemistry Compilation for 18 Welds Used in Weld Deposit C-Ring Testing										
Detection Method	Pb (ppm)	Bi (ppm)	Sb (ppm)	Sn (ppm)	Nb (ppm)	P (ppm)	Co (ppm)	S (ppm)	As (ppm)	B (ppm)
T-22V-39	1.1	<0.2	7	27	130	50	71	40	39	22
T-22V-40	<0.2	<0.2	4	6	110	40	52	10	29	4
T-22V-41	0.6	<0.2	9	35	91	60	95	30	52	8
T-22V-42	0.6	<0.2	9	34	94	60	90	30	49	5
T-22V-41-D-Pb	3	<0.2	10	44	67	60	73	50	43	<1
T-22V-41-D-Bi	0.5	2.2	11	47	72	60	82	60	43	<1
T-22V-41-D-Sb	0.4	<0.2	43	5	62	50	58	50	16	<1
T-22V-41-D-Pb+Sb+Bi	2.2	0.7	41	8	67	50	26	40	18	<1
T-22V-72	0.8	<0.2	6	25	110	60	65	50	25	1
T-22V-73	0.9	<0.2	5	19	77	70	56	50	18	<1
T-22V-47-D-Pb (3.5ppm)	3.7	<0.2	6	23	86	70	87	70	19	<1
T-22V-47-D-Pb (9.5ppm)	9.5	<0.2	5	18	74	70	54	50	17	<1
T-STD(P22)-13	1.1	<0.2	11	46	<1	100	120	60	38	<1
T-STD(P22)-13-D-Pb	4.8	<0.2	10	45	<1	151	120	60	40	<1
T-22V-47	2.3	<0.2	6	25	90	56	65	40	20	1
T-22V-48	1.2	<0.2	3	23	78	59	56	46	16	<1
C-22V-1	<0.2	<0.2	3	7.8	130	70	39	30	31	6
C-22V-2	<0.2	<0.2	6	27	76	90	52	40	32	<1

The SAW weld deposits that revealed reheat cracking at 55Ksi (380MPa) and 70Ksi (480MPa) for 2-hour exposure times reflect cause for concern of deposit cracking under normal welding conditions. Welding consumables which reveal weld deposit cracking at 55Ksi should be substituted for alternative consumable lots or consumables from a different consumable manufacture. Special precautions can and should be used with any weld that exhibit deposit cracking at a level of 3, 70Ksi (480MPa), so as to produce a weld deposit less susceptible to reheat cracking. This would include welding procedures that minimize the extent of the coarse-grained regions, taking steps to reduce residual stress in the weld, and removing/eliminating any stress concentrators that could serve as initiation sites for reheat-cracks.

Welds revealing deposit cracking at a stress of 85Ksi (590MPa) or 100Ksi (690MPa), levels 2 and 1 respectively, are considered to have a low sensitivity to reheat cracking and the consumables are acceptable if proper welding practices are followed. Weld deposits revealing cracks only at 100Ksi (690MPa), level 1, are considered virtually immune to reheat cracking.

The four welds produced with commercial wire-flux combinations (T-22V-39, T-22V-40, T-22V-41, and T-22V-42) showed a wide range of reheat cracking sensitivity depending on manufacturer. The T-22V-39 weld deposit cracked at Level 3, while the T-22V-41 and T-22V-42 deposits showed a ranking of 2, and the T-22V-40 weld deposit was virtually immune to reheat cracking at a ranking of 1. The T-22V-40 weld deposit contains a higher level of vanadium (0.34 compared to ~0.26) though this is counter intuitive as vanadium has been shown to correlate with a higher sensitivity to reheat cracking. The T-22V-39 weld deposit had a high sensitivity to reheat cracking (Level 3) and also had the highest lead level of 1.1 ppm compared to the other weld deposits made with different commercial wire and flux combinations which contained lead levels below 0.6ppm. The T-22V-41 and T-22V-42 weld deposits were both made with the same consumables but have different weld heat inputs. Thus, it can be surmised that a limited change in heat input will have a minimal effect on weld deposit reheat cracking as both weld deposits are ranked at Level 2.

A standard 2¼Cr-1Mo (P22) alloy weld deposit designated as T-STD (P22)-13 was added to the study to determine if the NCRRECT could be adopted for use with other alloys, as well as to act as a control datum in this study. Standard P22 deposit is known to be minimally susceptible to



reheat cracking compared to the vanadium bearing version (22V). The NCRRCT confirmed this as the T-STD(P22)-13 weld deposit achieved a reheat cracking sensitivity Level of 1, indicating that the weld deposit was virtually immune to reheat cracking.

Seven of the weld deposits evaluated in this study contained some form of elemental doping to define the effect of tramp elements on weld deposit reheat cracking. These welds were intentionally doped by adding the tramp element dopant to the flux in known quantities in be incorporated into the weld deposit. These seven welds(highlighted in yellow) along with the other 11 weld deposits are shown below in Table 6 with their corresponding lead, bismuth and antimony levels, reheat cracking factor “K”, and NCRRCT sensitivity ranking.

**Table 8. Chemical analysis, reheat cracking factor “K”, and NCCRCT sensitivity ranking for the 18 weld deposits used in development of the NCCRCT. Welds intentionally doped are highlighted in yellow.**

Weld Deposit Designation	Pb (ppm)	Bi (ppm)	Sb (ppm)	Reheat Cracking Factor "K"	NCCRCT Sensitivity Level
T-22V-41-D-Sb (43ppm)	0.4	<0.2	43	1.9	1
T-22V-40	<0.2	<0.2	4	0.5	1
C-22V-1	<0.2	<0.2	3	0.5	1
C-22V-2	<0.2	<0.2	6	0.6	1
T-STD(P22)-13	1.1	<0.2	11	1.6	1
T-STD(P22)-13-D-Pb (4.8ppm)	4.8	<0.2	10	5.3	1
T-22V-41	0.6	<0.2	9	1.1	2
T-22V-42	0.6	<0.2	9	1.1	2
T-22V-72	0.8	<0.2	6	1.2	2
T-22V-73	0.9	<0.2	5	1.3	2
T-22V-47	2.3	<0.2	6	2.7	2
T-22V-48	1.2	<0.2	3	1.5	2
T-22V-39	1.1	<0.2	7	1.5	3
T-22V-41-D-Pb (2.2ppm)+Sb(0.7ppm)+Bi(41ppm)	2.2	0.7	41	4.1	3
T-22V-47-D-Pb (3.5ppm)	3.7	<0.2	6	4.1	3
T-22V-47-D-Pb (9.5ppm)	9.5	<0.2	5	9.9	3
T-22V-41-D-Pb (3.0ppm)	3	<0.2	10	3.5	4
T-22V-41-D-Bi (2.2ppm)	0.5	2.2	11	3.0	4

The results of the evaluation show a clear pattern. Small amounts of lead and bismuth are highly detrimental to the reheat cracking sensitivity of 22V, therefore these elemental species should be carefully controlled as to their introduction into the weld deposit.

The only 22V weld deposits to score a ranking of Level 1 contained lead levels less than 0.4ppm. The welds produced by commercial fabricators(C-22V-1 and C-22V-2) were given a Level 1 ranking. Test welds T-22V-41-D-Sb (43ppm), T-22V-40 weld, and the P22 welds also receive a

Level 1 ranking. Weld deposits with a sensitivity ranking of 2 all had lead Levels ranging from 0.5-2.3ppm Pb. The weld deposits receiving a Level 2 ranking were all test welds with no intentional doping though the T-22V-47 weld deposit contained a high lead content for a un-doped weld. The only weld deposit with lead doping that did not show a high sensitivity (Level 3 or Level 4) to reheat cracking is the standard P22 alloy deposit. This is predictable as P22 weld deposits have a low sensitivity to reheat cracking due to the low levels of vanadium which is known to increase sensitivity to reheat cracking.

Weld doping with bismuth exacerbated reheat cracking in 22V weld deposits though; experience has shown that the occurrence of bismuth at concentrations greater than 0.2ppm is generally unlikely in normal 22V weld deposits than for lead which can more readily exceed a critical level. This is clearly seen as no un-doped welds in this study contained more than 0.2ppm bismuth.

Antimony appears to have the opposite effect on reheat cracking sensitivity. The sample doped only with antimony (T-22V-41-D-43ppm Sb) showed the least susceptibility to reheat cracking of any of the 18 welds used in this study. The effect of antimony may also be seen in the triple

doped specimen as this weld deposit did not result in the highest susceptibility, level 4, but rather Level 3, suggesting that antimony partially offset the negative effect of the lead and bismuth in the deposit. For these reasons, antimony could even be deemed as ameliorating or beneficial in mitigating reheat cracking.

The reheat cracking factor “K” proposed in a recent study of 22V welds was examined in the development of the NCRRCT [5]. The Pb, Bi, and Sb levels and calculated “K” factors for the 18 weld deposits are provided in Table 6.

$$K = \text{Pb} + \text{Bi} + 0.03 * \text{Sb} < 1.5$$

*Where Pb, Bi, and Sb are chemical contents in ppm*

It was found that lead and bismuth were indeed detrimental to reheat cracking, though antimony appeared to reduce reheat cracking susceptibility in 22V weld deposits. This is not in agreement with the “K” factor. Though 22V weld deposits performing the best in the NCRRCT did have low “K” factors, a smooth trend was not confirmed throughout the body of work. Therefore, it may be concluded that while the “K” factor has some relevance in identifying weld deposits susceptible to reheat cracking, a different reheat

cracking factor must be developed to better identify susceptible weld deposits before wide spread acceptance of the “K” factor takes place.

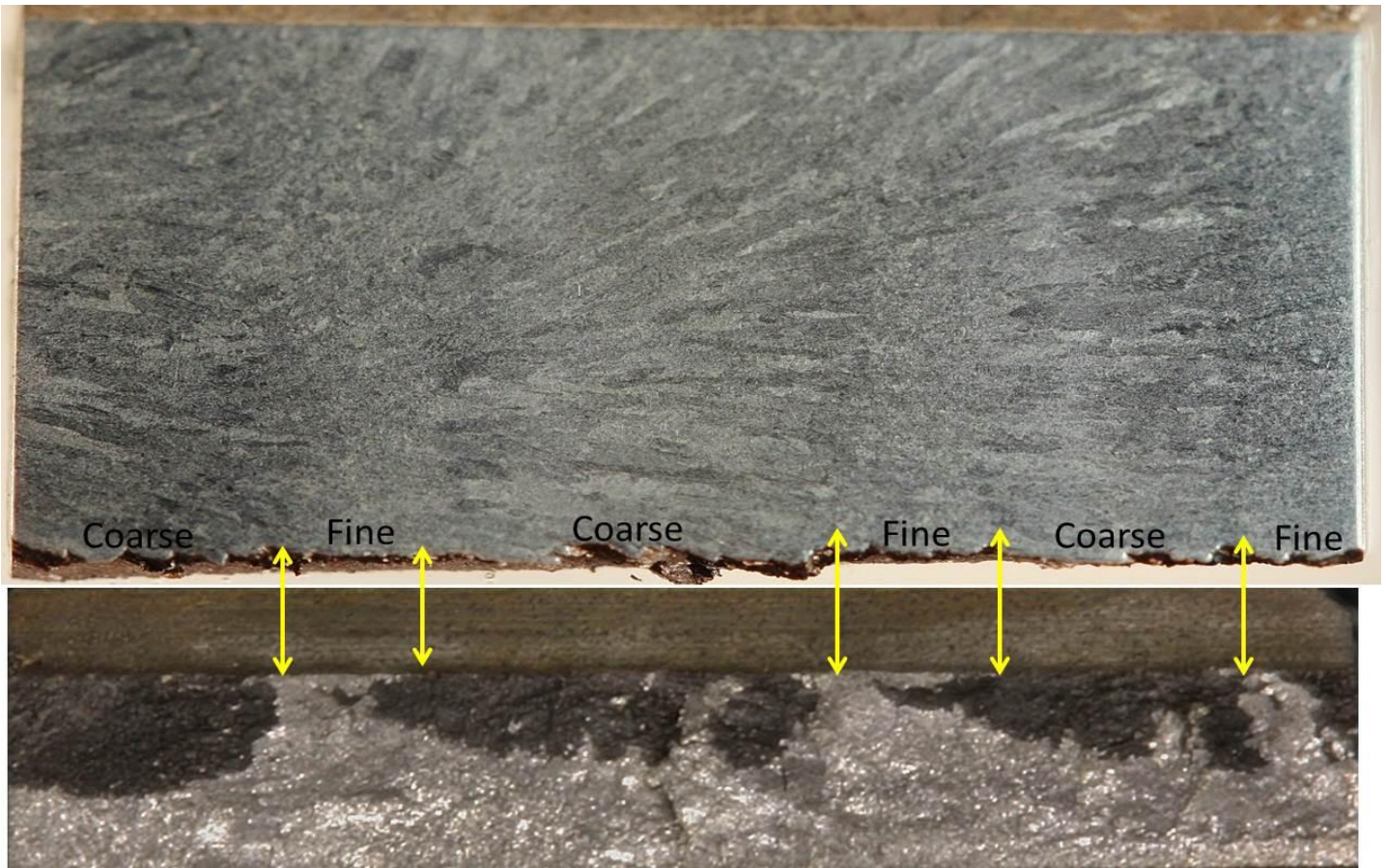
Precisely how these low level elemental additions affect the reheat cracking susceptibility in 22V weld deposit is still unknown. Nevertheless, these elements are present at exceedingly low concentrations, yet still have a marked effect on the reheat cracking susceptibility. Lead and bismuth are practically insoluble in solid and liquid iron while antimony is completely soluble in solid and liquid iron. Auger spectroscopy proved ineffective in quantifying amounts of the tramp elements on fracture surfaces due to the low levels. For these reasons it is difficult to understand basic phenomena that make lead and bismuth so detrimental to reheat cracking susceptibility.

The four welds with different welding parameters and bead stack patterns all earned the same reheat cracking sensitivity ranking of Level 2. Therefore it may be concluded that while the coarse grained regions will always be the first to crack, they do significantly change the overall reheat cracking potential.

The two commercial 22V submerged arc welds examined in this study were extracted from a pressure vessel and a fabricator’s process qualification (PQ) coupon test plate. C-22V-1 has a “Vee” groove geometry

which is common in the pressure vessel industry, see Figure 22. C-22V-2 has a narrow gap geometry which is another geometry used to save material and reduce welding time, see Figure 22. Both of these weld deposits proved to be virtually immune to reheat cracking by earning a Level 1 ranking. These weld deposits contained low levels of lead and bismuth (<0.2ppm) which might account for the low sensitivity to reheat cracking. It is important to note that the C-22V-1 weld deposit chemistry was very similar to the T-22V-40 suggesting that the same welding consumables were used, meaning that the NCRRCT successfully ranked both weld deposits at Level 1.

One of the universal observations is that reheat cracking always initiated in the coarse grained regions of a weld deposit (not refined by subsequent passes). This observation is highlighted in the macrograph in Figure 28, which shows the polished and etched macrostructure adjacent to the notch juxtaposed with the corresponding cryo-cracked fracture surface. The correspondence between the reheat-cracked areas (oxidized) and the coarse grained microstructure is further defined by the lines separating the coarse grained regions from the fine grained cryo-crack fractured regions at the root of the notch for each weld bead. A one to one correspondence is clearly revealed.



**Figure 28. Relationship between cryo-cracked specimen fracture surface appearance and microstructure at the root of the notch. ~10X, 10% ammonium persulfate etch.**

The NCRRCT is designed to evaluate weld deposits starting in the as-welded condition (no prior exposure to any postweld heat treatments DHT, ISR, or PWHT). However, to examine the reheat cracking susceptibility of weld deposits after exposure to a series of heat treatments, C-Rings were exposed to a series of postweld heat treatments including

DHT, ISR, and a PWHT of 8 hours at 705°C (1301°F) before being loaded with the stressing bolt and tested. The C-Rings loaded after the post weld heat treatments showed no susceptibility to reheat cracking. This shows that a PWHT can immunize a 22V weld deposit to reheat cracking if the weld is able to endure the treatment. This is due to the stress relief that naturally occurs as the yield stresses are lowered at the elevated temperatures and microstructural changes that take place as carbides grow, thus strengthening the matrix.

Stress risers have proven to be a virtual necessity to initiate a reheat crack. This was confirmed during the development of the NCRRCT. C-Rings tested without a notch showed no susceptibility to reheat cracking. Again this shows that a weld fabricated without stress risers is significantly less likely to experience reheat cracking.



## **VI. Conclusions**

The purpose of this study was to develop a test (the NCRRECT) that could accurately identify 22V submerged arc weld deposits that are susceptible to reheat cracking. The conclusions derived from the study may be summarized as follows.

1. The NCRRECT meets all requirements of the Ideal weldability test[1].
  - Simple
  - Cost effective
  - Shows direct correlation with actual fabrication
  - Reproducible
  - Amenable to a wide variety of welding variables
2. The NCRRECT test can accurately rank the reheat cracking susceptibility of welding processes and consumables on a Go/No-Go basis.
3. 22V weld deposits are more susceptible to reheat cracking than the non-vanadium bearing P22 alloy.
4. Lead and bismuth significantly increase susceptibility to reheat cracking in 22V weld deposits.

5. Antimony has a beneficial effect in regard to reheat cracking in 22V weld deposits.
6. The coarse grained regions in weld deposits are more susceptible to reheat cracking than the fine grained regions.
7. Weld bead placement does not have a significant effect on the reheat cracking susceptibility in 22V weld deposits.
8. The NCRRCT is born out of a successful historical development dating to 1985.
9. The NCRRCT can be conducted by anyone with access to a machining facility and a small furnace.
10. The test can be used to study the basic mechanisms of reheat cracking.
11. The test can be employed for evaluating all welding processes and associated consumables.

## **VII. Future Work**

1. Conduct “round-robin” testing to assure the validity of the test.
2. Proposed test for inclusion into API 934.
3. Obtain samples from problem welds dating back to 2008 for bench marking against commercially fabricated cracked weld deposits.
4. Utilize the NCCRCT to improve understanding of the basic mechanisms behind reheat cracking
5. A carbide study to identify the carbide evolution in 22V weld deposits.
6. Perform a more definitive surface analysis to better understand the role of tramp elements such as lead, bismuth, and antimony in regard to reheat cracking

## List of References

1. Kammer, P.A., Masubuchi, K., and Monroe, R. E., *Cracking in High Strength Steel Weldments – A Critical Review Appendix A*. DMIC Report 1964. **197**(feb): p. A-1 - A-20.
2. Geology, S.J.V., 2011.
3. API, *Fabrication Considerations for Vanadium-Modified Cr-Mo Steel Heavy Wall Pressure Vessels*. **934-B**.
4. *An MPC Program to Upgrade Materials and Process Standards for Fabrication of Heavy Wall Vessels of 2 1/4Cr -1Mo -1/4V Alloy for Service with Hydrogen at High Pressures and Temperatures*. Welding Research News, 2009.
5. Chauvy, C., Pillot, S., *Prevention of Weld Metal Reheat Cracking During Cr-Mo-V Heavy Reactors Fabrication*. Proceedings of the ASME 2009 Pressure Vessels and Piping Division Conference, 2009. **PVP2009**.
6. Park, K., Kim, S., Chang, J., and Lee, C., *Post-Weld Heat Treatment Cracking Susceptibility of T23 Weld Metals for Fossil Fuel Applications*. Materials Design, 2011. **34**: p. 699-706.
7. Communication, P., *PWHT Cracking in SA 517H Structural Steel*. 1982.
8. Lundin, C.D., Richey, M. W., and Henning, J. A., *Transformation, Metallurgical Response and Behavior of the Weld Fusion Zone and Heat Affected Zone in Cr-Mo Steels for Fossil Energy Applications*. Final Report for U.S. Department of Energy, ORNL/sub/81-7685/01&77, 1984.
9. Lundin, C.D., Henning, J. A., Menon, R., and Khan, K. K. , *Transformation, Metallurgical Response and Behavior of the Weld Fusion Zone and Heat Affected Zone in Cr-Mo Steels for Fossil Energy Applications*. Final Report for U.S. Department of Energy, ORNL/Sub/81-07685/02&77, 1987.
10. Lundin, C.D., Richey, M. W., and Henning, J. A., *Transformation, Metallurgical Response and Behavior of the Weld Fusion Zone and Heat Affected Zone in Cr-Mo Steels for Fossil Energy Applications*. Welding Research and Engineering the University of Tennessee Knoxville, 1987.
11. Lundin, C.D., Menon, R. , *Postweld Heat Treatment Cracking in HSLA Steels*. Proceedings of the International Welding Conference (IWC-87), 1987: p. 1097-1111.
12. Lundin, C.D., Henning, J. A., Menon, R., and Todd, J. A., *Postweld Heat Treatment Cracking in Chromium-Molybdenum Steels*. Welding Research Council Bulletin, 1989. **349**: p. 1-21.
13. Lundin, C.D., Menon, R., and Chen, Z. , *Postweld Heat Treatment Cracking in High Strength Low Alloy Steels*. Welding Research Council Bulletin, 1989. **349**: p. 22-30.
14. Lundin, C.D., Khan, K. K., and Gill, T. P. S. , *PWHT/Reheat/Stress Rupture Cracking and Heat Affected Zone Toughness in Cu-Precipitation Hardenable Steel-ASTM A710*. Proceedings of International Conference on The Metallurgy, Welding, and Qualification of Microalloyed (HSLA) Steel Weldments, 1990: p. 250-275.
15. Lundin, C.D., Liu, P., Qiao, C.Y. P., Zhou, G., Khan, K. K., and Prager, M. , *An Experimental Study of Causes and Repair of Cracking of 1 1/4Cr-1/2Mo Steel Equipment*. Welding Research Council, 1996. **411**: p. 1-215.
16. Lundin, C.D., Henning, J.A., Menon, R., and Todd, J. A., *Carbide Evolution Kinetics in Weld CGHAZ and Weld Reheat Cracking Susceptibility of Cr-Mo Steel*. Proceedings of Pre-Assembly Symposium of 47th Annual Assembly of IIW on Welding, Joining, Coating and Surface Modification of Advanced Materials, 1984: p. 105-113.
17. Lundin, C.D., Khan, K. K., Liu, P., Qiao, C. Y. P., Zhou, G., and Prager, M. , *Specifying 1 1/4Cr-1/2Mo Steels for Freedom from Cracking in Hydroprocessing Service*. Proceedings of the Second International Conference on Interaction of Steels with Hydrogen in Petroleum Industry Pressure Vessel and Pipeline Service, 1994: p. 55-71.
18. Lundin, C.D., Prager, M., *Repair and Fabrication Practices for 1 1/4Cr-1/2Mo Steel*. Proceedings of the Second International Conference on Interaction of Steels with Hydrogen in Petroleum Industry Pressure Vessel and Pipeline Service, 1994. **1**: p. 223-229.

19. Lundin, C.D., *Overview of Results from PVRC Program on Half-Bead/Temper-Bead/Controlled Deposition Techniques for Improvement of Fabrication and Service Performance*. Welding Research Council Bulletin 1996. **412**: p. 16-26.
20. Lundin, C.D., Khan, K. K., *Fundamental Studies of the Metallurgical Causes and Mitigation of Reheat Cracking in 1 1/4Cr-1/2Mo and 2 1/4Cr-1Mo Steels*. Welding Research Council Bulletin, 1996. **409**.
21. Lundin, C.D., Peng, L., *Reheat Cracking Susceptibility of A Newly Introduced W-Nb-V-N-B Modified 2 1/4Cr Steel (T23)*. Journal of Materials Processing Technology, 2001.
22. Menon, R., Lundin, C.D., and Chen, Z. , *Postweld Heat Treatment Cracking in High Strength Low Alloy Steels*. Welding Research Council Bulletin, 1989. **349**.
23. Reed-Hill, R.E., *Precipitation Hardening*. Physical Metallurgy Principles, 1973: p. 358-377.
24. Dieter, G.E., *creep and Stress Rupture*. Mechanical Metallurgy, 1976: p. 451-489.
25. Erwin, W.E., Kerr, J. G., *The Use of Quenched and Tempered 2 ¼ Cr -1Mo Steel for Thick Wall Reactor Vessels in Petroleum Refining Processes: an Interpretive Review of 25 Years of Research and Application*. Welding Research Council Bulletin, 1982. **275**.
26. Kou, S., *Welding metallurgy*. 2003.
27. Chipman, J., *Physical Chemistry of Liquid Steel, Basic Open Hearth Steel Making*. 1951(2): p. 621-691.
28. Meitzner, C.F., *Stress Relief Cracking in Steel Weldments*. Welding Research Bulletin, 1975. **211**.
29. Tamaki, K., Suzuki, J., and Min-Long, L., *Influence of Vanadium Carbide on Reheat Cracking of Cr-Mo Steels\* Study of Reheat Cracking of Cr-Mo Steels*. 1993. **10**.
30. Tamaki, K., and Suzuki, J., *Reheat Cracking on High Strength Steels by a Modified Implant Test*. Transactions of the Japan Welding Society, 1983. **14**(2).
31. Nawrocki, J.G., DuPont, J. N., Robino, C.V., Puskar, J. D., and Marder, A.R., *The Mechanism of Stress Relief Cracking in a Ferritic Alloy Steel*. The Welding Journal, 2003: p. 25-35.
32. Swift, R.A., *Creep-Rupture Test on 2 1/4Cr 1Mo Simulated Heat Affected Zone*. Luken Steel Company Research Report RD 69-11 1969.
33. Vinckier, A.G., Pense, A.W., *A Review of Underclad Cracking in Pressure-Vessel Components*. Welding Research Bulletin 1974. **197**.
34. Heo, N.H., Chang, J.C., Yoo, K.B., Lee, J.K., and Kim, J., *The Mechanism of Elevated Temperature Intergranular Cracking in Heat Resistant Alloys*. Materials Science and Engineering A, 2010. **528**: p. 2678-2685.
35. Edwards, R.H., Barbaro, F. G., and Gunn, K. W., *Stress Relief Cracking in 2.25 Cr 1mo V steels*. Metals Forum, 1982. **5**(2): p. 119-129.
36. Meitzner, C.F., Pense, A. W. , *Steel Relief Cracking in Low-Alloy Steel Weldments*. Welding Journal, 1959. **48**(10): p. 431s-440s.
37. Easterling, K., *Introduction to the Physical Metallurgy of Welding*. 1983.
38. Edwards, R.H., Barbaro, F. J., and Gunn, K. W. , *Stress Relief Cracking in Cr-Mo-V Steels*. Met. Forum, 1982. **5**(2): p. 119-129.
39. Nawrocki, J.G., Dupont, J.N., Robino, C.V., and Marder, A.R., *The Stress-Relief Cracking Susceptibility of a New Ferritic Steel - Part 2: Multiple Pass Heat-Affected Zone Simulations* Welding Research Supplement, 2001: p. 18-s-24-s.
40. Glossop, B.A., Eaton, N. F., and Boniszewski, T. , *Reheat Cracking in Cr-Mo-V Steel Weldments, in Metal Construction* 1969.
41. Lundin, C.D., Liu, P., *Development of W-Nb-V Modified Low Carbon Filler Metals for Fabrication and Repair of 1 1/4Cr-1/2mo Steel Weldments*. Welding Research Council Bulletin, 1999. **439**.
42. Hunter, N.R., *Reheat Cracking in 2.25Cr 1Mo Submerged Arc Weld Metal. Part 1 Materials, Welding, and Testing*. Metal Construction, 1982. **4**(1): p. 198-270.

43. McCullough, C., Baker, A. J. , *The Role of Grain Boundary Migration in Reheat Cracking*. Acta Metall, Mater, 1991. **39**(12): p. 3217-3225.
44. API, *Inspection Procedures for Transverse Reheat Cracking*. 2007(934-A).
45. Linnert, G.E., *Welding Metallurgy* 1967. **2**
46. Hipsley, C.A., Knott, J.F., and Edwards, B.C., *A Study of Stress Relief Cracking in 2.25Cr 1Mo Steel - II. The Effects of Multi-Component Segregation*. Acta Metall, Mater, 1981. **30**: p. 641-654.
47. Dhooge, A., Dolby, R.E., Sebile, J., Steinmetz, R., and Vinckier, A.G., *A Review of Work Related to Reheat Cracking in Nuclear Reactor Pressure Vessel Steels*. International Journal of Pressure Vessels and piping, 1978. **6**.
48. Ito, Y., Nakanishi, M., *Study on Stress Relief Cracking in Welding Low Alloy Steels* The Sumitomo Search, 1972. **7**.
49. Baker, R.G., Nutting, *the Tempering of 2.25Cr-Mo-V Steel after Quenching and Tempering*. Journal of the Iron and Steel Institute, 1959. **192**: p. 275-268.
50. Indacochea, J.E., *Cr-Mo Steel Welding Metallurgy*. Key Engineering Materials 1992. **69-70**.
51. B. A. Glossop, N.F.E., and T. Boniszewski, *Reheat Cracking in Cr-Mo-V Steel Weldments* Metal Construction, 1969. **1**(Feb ).
52. Hucinska, J., *Advanced Vanadium Modified Steels for High Pressure Hydrogen Reactors*. Advances in Materials Science, 2003. **4**(4).
53. Ishiguro, T., Ohnishi, K., and Watanabe, J., *TetsuToHagane*. ISIJ, 1985. **71**: p. 986.
54. Nakamura, H., Naiki, T., and Okabayashi, H., *Fracture in the Process of Stress-Relaxation Under Constant Strain*. 1st International Conference on Fracture 1965. **2**: p. 863-878.
55. Boniszski, T., Sato, S., Shimomura, J. and Aso, K., *Reheat Cracking in 2.25Cr-1Mo SA Weld Metal*. Metal Construction, 1982. **14**(9): p. 495-496.
56. Bruscato, R., *Temper Embrittlement and Creep Embrittlement of 2 1/4Cr 1 Mo Shielded Metal-Arc Weld Deposits*. Welding Research Supplement, 1970: p. 128-156.
57. Yu, J., McMahan, C.J. Jr, *The Effects of Composition and Carbide Precipitation on Temper Embrittlement of 2.25 Cr-1Mo Steel:Part 1. Effects of P and Sn*. Metallurgical Transaction, 1980. **11A**: p. 277-289.
58. Lundin, C.D., Kelly, S. C., Menon, R., and Kruse, B. J., *Stress Rupture Behavior of Postweld Heat Treated 2-1/4Cr-1Mo Steel Weld Metal*. Welding Research Bulletin 1986. **315**.
59. Anon, *Testing Techniques to study the susceptibility to Reheat Cracking of Carbon-Manganese and Low Alloy Steels*. Welding in the World, 1974. **11**(11/12).
60. Vinckier, A.c., *Testing Techniques to Study the Suseptibility to Reheat Cracking of Carbon-Manganese and Low Alloy Steels*. Weld World, 1974. **12**: p. 1-22.
61. Myers, J., *The Influence of Impurity and Alloy Content on Stress Relief Cracking in CrMoV Steels*. Metals Technology, 1978. **5**.
62. Harris, P., Jones, K. E., *The Effect of Composition and Deoxidation Practice on the Reheat Cracking Tendencies of 1/2Cr 1/2Mo 1/4V Steel*. Proceedings of International Conference on Welding Research Related to Power Plants, 1972: p. 369-380.
63. Corporation, K.S., *Improvement in High Temperature Properties of Heavy Section 2 1/4Cr-1Mo Steel*. 1982.
64. Lewandowski, J.J., Hipsley, C. A., and Knott, J. F. , *Effects of Impurity Segregation on Sustained Load Cracking of 2 1/4Cr 1Mo Steels Crack Initiation*. Acta Metall, Mater, 1987. **35**(3): p. 593-608.
65. Shinya, T., Tomita, Y., *Effect of Calcium Treatments and Strain Rate on Reheat Cracking of Vanadium-Modified 2.25Cr-1Mo Steel*. Materials Characterization 1998. **40**: p. 221-225.
66. Wyatt, L.M., (chrnm) and Edmondson, B., (rapporteur), *Rapporteur's Remarks and Discussion (Discussion of Papers 24-31)*. Proc. Of Cof. Welding Research Related to Power Plant, 1972.

67. Dooge, A., Vinckier, A., *Reheat Cracking- a Review of Recent Studies*. International Journal of Pressure Vessels and Piping, 1987. **27**: p. 239-269.
68. Chovet, C., Schmitt, J. P., *Additional Recommendations for Welding Cr-Mo-V Steels for Petrochemical Applications*. Air Liquide, 2011.
69. Romanelli, M., Tognarelli, L., Giorni, E., and Magnasco, M., *Test Method to Prevent Reheat Cracking on Welded Reactors*. Proceedings of ICPVT, 2009. **12**.
70. Lundin, C.D., Menon, R., *Weldability of Cast Carbon and Low Alloy Steels - Effect of Microstructure on the Hydrogen Induced HAZ Cracking Susceptibility*. Research Report No. 96, Steel Founders' Society, 1985. **96**.
71. Burgess, J.D., Lundin, C. D., , *Evaluation of Etchants for Revealing Macrostructure in 2 ¼ Cr-1Mo-V SAW Weld Deposits*. 2011.



## Appendix

**The protocol for employing the notched C-Ring reheat cracking test to determine reheat cracking sensitivity of SAW Cr-Mo-V weld deposits**

1. Extract a cylindrical slug from the weld deposit of a production weld or from the weld in a procedure qualification coupon according to Figure 24.
  
2. Bore/machine the C-Ring cylindrical slug into a tube with a 1.0” (2.54 cm) diameter and a wall thickness of 0.125” (0.3 cm).
  
3. Cut/machine the C-Ring to a length of 0.75” (1.9 cm).
  
4. Polish the OD of the C-Ring to a 600 grit surface finish (minimum) and etch with 10% Ammonium Persulfate or other suitable etch which reveals the solidification macro-structure of the weld deposit (see Figure 23).
  
5. Select location of the notch based on the weld macrostructure (notch should traverse several weld overlapped deposit regions).
  
6. Machine, broach or grind a notch into the OD surface to a depth 0.030” (0.075 cm) using the Charpy “Vee” notch geometry given in ASTM E 23. (Note the reduction in the notch depth as compared to the standard Charpy sample used for toughness testing).
  
7. Drill holes through the notched C-Ring, 90° to the notch, with clearance for a 1/4” (0.63cm) threaded rod (bolt). The threaded rod (bolt) should

have 1/4-28 threads or nearest SI thread dimensions. The threaded rod (bolt) must be made from 2¼Cr-1Mo-¼V material.

8. Stress the notched C-Ring according to ASTM G 38 using the calculation therein for a particular nominal stress. Deflection of the notched C-Ring for any nominal stress assumes that the diameter of the notched C-Ring is measured at the root of the notch (0.94” 2.39 cm). Table 5 can be referenced for deflections pre-calculated using ASTM G-38. The calculated deflection necessary for any “nominal” stress is the reduction in outside diameter at the location of the stressing bolts (the effect of the notch as a stress raiser must be taken into account to obtain the effective stress at the root of the notch).

9. As a starting point, stress a notched C-Ring to 85Ksi (590MPa) nominal stress. Heat the stressed C-Ring in a furnace to 1150°F (621°C) at an approximate rate of 10 F°/min (6 C°/min). When the notched C-Ring reaches 1150°F (621°C) hold for 2 hours. Remove the oxide formed during thermal exposure by placing the notched C-Ring in a 50% HCl and water solution (at ambient temperature) to which several drops of an organic inhibitor is added (such as Halliburton HAI-OS) for 5 minutes. Rinse and scrub with a nylon brush. Rinse again with alcohol and hot air dry.

Examine the notched C-Ring sample at the root of the notch at 40-50X magnification with a binocular stereo microscope for evidence of cracking. If there is cracking note the locations. This observational procedure is followed after each test. If no cracking is present at the 85Ksi (590MPa), stress a new notched C-Ring to 100Ksi (690MPa) and repeat the test. After the 100Ksi (690MPa) test, cracking will denote a sensitivity ranking of Level 1.

If there is cracking at the nominal 85Ksi (590MPa) stress after the 2 hour exposure. Expose a new notched C-Ring nominally stressed to 70Ksi (480MPa) and repeat the entire evaluation process by heating the notched C-Ring to 1150°F (621°C) and hold for a time of 2 hours. If cracking has not occurred, the C-Ring will be given a Level 2 ranking. If cracking takes place at the 70Ksi (480MPa) stress Level, a new notched C-Ring should be tested at 55Ksi (380MPa). A no-crack result at the 55Ksi (380MPa) will denote a Level 3 sensitivity ranking. If cracks are found after testing at the 55Ksi (380MPa) stress the weld deposit will be assigned a Level 4 sensitivity ranking. This procedure will define 22V weld deposits with the appropriate reheat cracking sensitivity "Level".

The above procedure will result in the assignment of the weld deposit to one of 4 Levels of cracking behavior. The 4 Levels of assessment allow for the definitive ranking of weld deposit cracking.

10. Evaluation criteria for 2¼Cr-1Mo-¼V SAW weld deposit sensitivity to reheat cracking are suggested as follows: Based on testing to date the experimental evidence has shown that, most notched Cr-Mo-V SAW deposit notched C-Rings, stressed to a nominal stress of 100Ksi (690MPa) and tested at 1150°F (621°C) will crack within a time of 2 hours. Thus, the evaluation criteria for the 2¼Cr-1Mo-¼V SAW deposits is that if a notched C-Ring exhibits cracking at a nominal stress of 100Ksi (690MPa) with a thermal exposure at 1150°F (621°C) for 2 hours, the material is considered virtually immune to reheat cracking under normal weld deposition techniques and methods.

## **Commentary on Notched C-Ring Reheat Cracking Test Protocol**

This commentary amplifies and/or explains the protocol for 22V SAW weld deposit testing using the Notched C-Ring Reheat Cracking Test. The numbering in this commentary is identical to the numbering in the above protocol

1,2,3. The extraction of the cylindrical slug from a weldment can be done by sawing and conventional machining. However, EDM can be effectively employed to minimized final machining.

4. The polishing of the C-Ring to 600 grit and etching with an aqueous 10% Ammonium Persulfate solution works very well on the 22V alloy weld deposits as it produces significant contrast between weld beads and the overlapped regions. However, other etchants may be employed and different levels of polishing used to suit the material being evaluated.

5. The location of the notch (as shown in Figure 23) is significantly important, in that, it must traverse the overlapped and un-overlapped regions of the welds bead in the through thickness direction and should not be selected to reside solely in a completely refined region, such as in the central overlapped region of the side by side weld beads. The reasons for this positioning of the notch are that all of the weld regions must be

included in the Notched C-Ring reheat cracking assessment and the fact that certain portions of the overlapped region (fine-grained) may be much less sensitive than other regions of the weld. Thus, to arrive at a proper assessment all regions must be subjected to the stresses at the root of the notch of the C-Ring.

6. The notch may be created by any means which will produce the desired geometry (as per ASTM E 23) and required depth.

7. Fine threading of the bolts is considered important so that the proper deflection can be obtained during bolt tightening. The bolt material must match the material being tested so as to match the expansion coefficients and to provide for a more realistic stress relaxation.

8. The nominal stress is imposed by deflecting the notched C-Ring (by tightening the bolt) should be calculated using the 0.94" (2.39 cm) notched C-Ring diameter at the root of the notch. The effective stress at the notch root is to be considered as the nominal stress. A notch is employed in the C-Ring testing as it has been found that in virtually all of the occurrences of reheat cracking in actual weldments a stress amplifying discontinuity exists in the particular weld region, a necessary condition for the initiation of reheat cracking.

9. The heating rate to the ISR/PWHT test temperature is relatively unimportant but it should not be significantly faster than that indicated in the protocol and may be considered to be somewhat similar to the actual heat treatment of a vessel. The 1150°F (621°C) test temperature is considered similar to a typical ISR temperature and further, it is also considered as the temperature at which the minimum time for reheat cracking to occur (reheat cracking response is a typical C-curve phenomenon with the nose of the C-curve at approximately 1150°F (621°C)). A hold at 1150°F (621°C) is introduced to insure that the nose of the C-curve is intersected and thus provides for initiation of reheat cracking. If heat treatment in air is conducted, the surface of reheat cracks at the root of the notch will be oxidized. The light grey coloration of the oxidized surfaces provides for easy assessment of a crack-no-crack condition. However, if the test is conducted in an inert atmosphere one must rely on the fracture morphology to assess if cracking has occurred during the test. The benefits of testing a notched C-Ring in an inert atmosphere is that it provides for a clean (non-oxidized) reheat crack surface most suitable for SEM examination and evaluation.

10. The NCRRCT sensitivity protocol indicates that at a nominal stress of 85Ksi (590MPa) with clean (low tramp elements in the deposit) material



the deposit is significantly resistant to reheat cracking and at 100Ksi (690MPa) the material should show virtually no sensitivity to reheat cracking if good welding procedures are closely adhered to. However, for test condition cracking at 70Ksi (480MPa) the fabrication must adhere closely to optimum welding conditions to avoid reheat cracking. Cracking of a C-Ring at 55Ksi (380MPa) should reflect cause for concern even with the optimum welding procedures.

## **Vita**

Max Trent was born in Knoxville, TN to the parents of Kevin and Dianne Trent. He is the older brother to his sister Zoe. Max attended school at Powell Elementary and continued to Powell High School in Knoxville. After graduation, he began taking class at the University of Tennessee Knoxville where he soon became interested in the field of Materials Science and Engineering. Four years later he completed his BS in that field through UTK. Through an undergraduate study program Max became interested in metallurgy under close guidance of Dr. Carl D. Lundin and in 2010 he was offered a position in the Materials Joining Group to continue his education at the Graduate level. Max graduated with a Masters of Science Degree in Materials Science and Engineering with a concentration in Metallurgy in summer 2012. Max is continuing to pursue a career in this field.