



6-1986

# Characteristics of Thrust Fault Imbrication Along the Western Margin of the Blue Ridge Structural Province Buffalo Mountain, Tennessee

Mark Morgan Duddy  
*University of Tennessee, Knoxville*

---

## Recommended Citation

Duddy, Mark Morgan, "Characteristics of Thrust Fault Imbrication Along the Western Margin of the Blue Ridge Structural Province Buffalo Mountain, Tennessee. " Master's Thesis, University of Tennessee, 1986.  
[https://trace.tennessee.edu/utk\\_gradthes/4624](https://trace.tennessee.edu/utk_gradthes/4624)

This Thesis is brought to you for free and open access by the Graduate School at Trace: Tennessee Research and Creative Exchange. It has been accepted for inclusion in Masters Theses by an authorized administrator of Trace: Tennessee Research and Creative Exchange. For more information, please contact [trace@utk.edu](mailto:trace@utk.edu).

To the Graduate Council:

I am submitting herewith a thesis written by Mark Morgan Duddy entitled "Characteristics of Thrust Fault Imbrication Along the Western Margin of the Blue Ridge Structural Province Buffalo Mountain, Tennessee." I have examined the final electronic copy of this thesis for form and content and recommend that it be accepted in partial fulfillment of the requirements for the degree of Master of Science, with a major in Geology.

Nicholas B. Woodward, Major Professor

We have read this thesis and recommend its acceptance:

Kenneth Walker, Don Byerly

Accepted for the Council:

Dixie L. Thompson

Vice Provost and Dean of the Graduate School

(Original signatures are on file with official student records.)

---

168  
69

To the Graduate Council:

I am submitting herewith a thesis written by Mark Morgan Duddy entitled "Characteristics of Thrust Fault Imbrication Along the Western Margin of the Blue Ridge Structural Province Buffalo Mountain, Tennessee." I have examined the final copy of this thesis for form and content and recommend that it be accepted in partial fulfillment of the requirements for the degree of Master of Science, with a major in Geology.

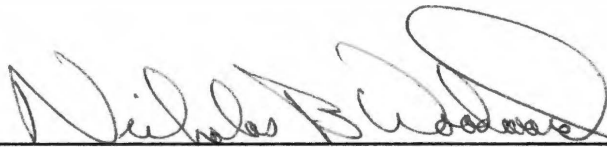
  
Nicholas B. Woodward, Major Professor

We have read this thesis and recommend its acceptance:

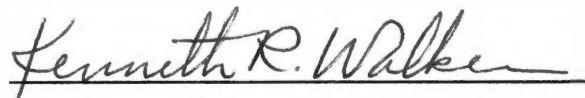
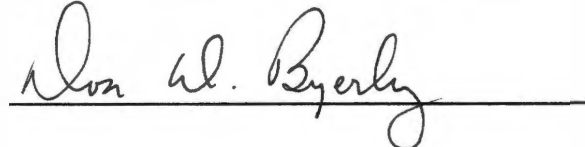
Accepted for the Council:

  
Vice Provost  
and Dean of The Graduate School

CHARACTERISTICS OF THRUST FAULT IMBRICATION ALONG THE  
WESTERN MARGIN OF THE BLUE RIDGE STRUCTURAL PROVINCE  
BUFFALO MOUNTAIN, TENNESSEE

A Thesis  
Presented for the  
Master of Science  
Degree  
The University of Tennessee, Knoxville

Mark Morgan Duddy

June 1986

## ACKNOWLEDGMENTS

I would like to thank my advisor Dr. Nick Woodward for suggesting my thesis topic and for providing financial support during my tenure. More importantly however, I would like to thank Nick for helping me to develop self confidence in my studies. Thanks also go to the other members of my committee, Dr. Ken Walker and Dr. Don Byerly, for reading my thesis and for providing constructive criticisms. Dr. John Rodgers of Yale University and Dr. Fred Diegel of The Johns Hopkins University helped me tremendously with several field discussions concerning the structural geology of northeastern Tennessee. I am also indebted to Dr. MaLaughlin and The University of Tennessee Department of Geological Sciences Discretionary Fund for supporting my research.

There are many students who have helped me along during the past few years. First, all the guys in the Structure Lab, especially Peter T. Regan and Charles Lutz. Second, I would like to acknowledge the friendship of Jon Conte, Jeff Gratz, George Harlow, Mike Kozar, Jonny Lewis, Joe Paul, and Ray Skelly.

Finally, I would like to thank my family for their continuing support. Thanks also goes to Mr. Walter Nicholson for his encouragement in my studies

## ABSTRACT

The Buffalo Mountain thrust sheet, located along the western margin of the Blue Ridge structural province in northeastern Tennessee, provides an excellent opportunity to examine transitional structural styles and deformational mechanisms between the Valley and Ridge and Blue Ridge.

The Buffalo Mountain sheet is composed of a sequence of Lower Cambrian Chilhowee Group clastics that have been thrust over Upper Cambrian Conasauga Group shales and Cambro- Ordovician Knox Group carbonates. The entire stack has been imbricated into four interleaved thrust slices and is folded into a northeast trending doubly plunging syncline.

Field mapping and indirect examination of thrust plane orientations reveal that all thrust faults in the area place older rocks over younger rocks, cut up stratigraphic section through both foot wall and hanging wall strata, and do not cross-cut or displace each other. These data suggest that the Buffalo Mountain area has experienced only one episode of contractional thrust faulting.

The structural relationships at Canah Hollow, along the southwestern corner of the Buffalo Mountain sheet, are interpreted as a foreland-dipping duplex. The duplex is composed of horses torn away from both the foot wall Holston Mountain sheet and the hanging wall Buffalo

Mountain sheet. The structural history of Canah Hollow provides an example of progressive deformation during a single episode of in-sequence thrusting.

The small klippe of Unicoi within Canah Hollow was originally part of the Pinnacle sheet, and has been repositioned by either minor faulting, erosional collapse, or mass wasting.

Small scale structures within the hanging wall rocks of the Buffalo Mountain thrust sheet include quartz-filled fractures, fractured grains, pressure solution traces, undulatory extinction, and just above the Buffalo Mountain thrust surface, ribboned quartz grains, and crenulation cleavage. The small scale structures associated with the foot wall rocks of the Buffalo Mountain sheet are characterized by a cataclastic fabric (crushed, cracked, and fractured grains) that lacks an internal foliation, stylonitic pressure solution traces, and mineral-filled conjugate en echelon fractures.

The large scale geometric relationships between major thrust sheets combined with the orientation of minor structures suggests that thrust sheet emplacement in the northeast Tennessee Blue Ridge has occurred in a hinterland to foreland fashion. Specifically, the folding of the Buffalo Mountain thrust sheet is probably due to the vise effect caused by the emplacement of the structurally lower, more foreland Limestone Cove duplex and Pulaski sheet.

The absence of a strain contrast across the Buffalo Mountain sheet combined with the laterally overlapping geometry of the imbricate sheets suggest that the imbricate sheets formed simultaneously during folding.

Thus, the Buffalo Mountain area provides a group of structurally complex features that have formed during a single progressive episode of hinterland to foreland thrusting.



## TABLE OF CONTENTS

CHAPTER	PAGE
I. INTRODUCTION . . . . .	1
Purpose and Scope of Study . . . . .	1
Location and Geography of Study Area . . . . .	3
Previous Investigations . . . . .	5
II. THRUST GEOMETRIES . . . . .	8
Introduction . . . . .	8
Definitions and Assumptions . . . . .	9
Thrust Systems . . . . .	13
III. STRATIGRAPHY . . . . .	17
Introduction . . . . .	17
Chilhowee Group . . . . .	19
Unicoi Formation . . . . .	22
Hampton Formation . . . . .	23
Erwin Formation . . . . .	24
Shady Dolomite . . . . .	25
Rome Formation . . . . .	27
Conasauga Group . . . . .	27
Honaker Dolomite . . . . .	28
Knox Group . . . . .	29
VI. REGIONAL STRUCTURE . . . . .	31
Introduction . . . . .	31
Holston Mountain Thrust Sheet . . . . .	33
Mountain City Window . . . . .	34

CHAPTER	PAGE
VI. (Continued)	
Buffalo Mountain-Del Rio Thrust Pile . . . . .	37
V. LOCAL STRUCTURAL GEOLOGY . . . . .	39
Introduction . . . . .	39
Map Relations and Larger Scale Features . . .	41
Cherokee Sheet . . . . .	41
Intermediate Sheet . . . . .	43
Pinnacle Sheet . . . . .	50
Ultrapinnacle Sheet . . . . .	51
Canah Hollow . . . . .	53
Three-dimensional Summary View . . . . .	55
VI. MESOFABRIC AND MICROFABRIC FEATURES . . . . .	61
Introduction . . . . .	61
Intermediate Sheet . . . . .	62
Pinnacle-Ultrapinnacle Sheets . . . . .	79
Canah Hollow . . . . .	88
VII. DISCUSSION . . . . .	89
Introduction . . . . .	89
Number of Thrust Generations . . . . .	89
Sequence of Thrust Sheet Emplacement . . . . .	112
Sequence of Thrust Sheet Imbrication . . . . .	118
IIX. CONCLUSIONS . . . . .	127
LIST OF REFERENCES . . . . .	130
APPENDIX . . . . .	140
VITA . . . . .	151

## LIST OF FIGURES

FIGURE	PAGE
1. Location map of the field area . . . . .	4
2. Successive interpretations of structure in northeast Tennessee . . . . .	7
3. The ideal thrust fault . . . . .	10
4. Relationship between ramps and flats in a thrust sequence . . . . .	10
5. Block diagram of a horse illustrating leading and trailing branch lines and hanging wall and foot wall cutoff lines . . . . .	12
6. Classification of thrust systems . . . . .	14
7. Characteristic map pattern and cross-section of hindward dipping duplex culmination . . . . .	16
8. Generalized stratigraphic column of the Buffalo Mountain area . . . . .	18
9. Restored depositional model for the Chilhowee Group in northeast Tennessee . . . . .	21
10. Regional structural map of the northeast Tennessee Blue Ridge . . . . .	32
11. General structure map of the Buffalo Mountain area showing the position of imbricate thrusts and sheets . . . . .	40
12. Branch-line map of the Buffalo Mountain area . . .	42

FIGURE	PAGE
13. Structure map of the Buffalo Mountain area showing the orientation of the Buffalo Mountain thrust and related imbricates . . . . .	44
14. Field photo of the Buffalo Mountain thrust fault and complexly folded Knox carbonates . . . . .	47
15. Field photo of minor antithetic contractional (thrust) fault and associated hanging wall anticline . . . . .	47
16. Geologic map of the Ashhopper Hollow area showing the southwestern end of the Ultrapinnacle sheet as mapped by Richard Ordway (1949, 1959) . . . . .	52
17. Geologic map of the Canah Hollow area showing the structural components of the area . . . . .	54
18. Trend and plunge of imbricate fault surfaces in the Buffalo Mountain area . . . . .	57
19. Along strike cross-section of the Pinnacle imbricate sheet based on the trend and plunge data in Figure 18 . . . . .	58
20. Serial down structural plunge projection of the Buffalo Mountain area . . . . .	59
21. Deep structure contour map of the Buffalo Mountain area . . . . .	60
22. Stereogram summary of the mesofabric elements associated with the complexly folded Knox . . . . .	63

FIGURE	PAGE
23. Photographs of Knox from the core and limb of the overturned syncline beneath the Buffalo Mountain thrust . . . . .	65
24. Schematic outcrop sketch of the mesofabric elements associated with the complexly folded Knox . . . . .	69
25. Summary diagram showing the relationship of mesofabrics to folds found in the southern Canadian Rocky Mountain foreland belt . . . . .	69
26. Outcrop and hand sample photographs of the Buffalo Mountain thrust exposed 1 kilometer south of Cherokee Knob along TN 106 . . . . .	70
27. Hand sample and thin-section photographs of Knox from the foot wall of the Buffalo Mountain thrust near Cherokee Knob . . . . .	74
28. Photographs of deformational features found in the Hampton and Unicoi . . . . .	77
29. Photographs of deformational features above the Pinnacle imbricate and the Buffalo Mountain thrust . . . . .	82
30. Photographs of deformational features exposed at Ashhopper Hollow and in Canah Hollow . . . . .	86
31. Structure map of the Buffalo Mountain thrust sheet showing the orientation of the Buffalo Mountain thrust and related imbricates . . . . .	93

FIGURE	PAGE
32. Schematic cross-sections through the Buffalo Mountain thrust showing the relationship between the thrust and foot wall and hanging wall stratigraphy . . . . .	94
33. Structural interpretations of Canah Hollow by Ordway (1949, 1959) . . . . .	96
34. Structural cross-section of Canah Hollow . . . . .	98
35. Sequential development of the foreland-dipping duplex at Canah Hollow . . . . .	99
36. Structure contour map of the Pinnacle imbricate sheet assuming that the Unicoi klippe is an extension of the Pinnacle sheet . . . . .	101
37. Multiple thrust model to explain the position of the Unicoi klippe at Canah Hollow . . . . .	103
38. Geologic map of Canah Hollow assuming a consistent internal stratigraphy . . . . .	105
39. Structural cross-section of Shady in Canah Hollow based on Figure 38 . . . . .	106
40. Geologic map of Canah Hollow assuming a complex three-dimensional mosaic of blue, white, and ribboned dolomite facies within the Shady . . .	108
41. Erosional collapse model to explain the position of the Unicoi klippe at Canah Hollow . . . . .	109
42. The orientation of small scale structures in foreland-dipping thrust networks . . . . .	115

FIGURE	PAGE
43. Development of folded faults during a single phase of hinterland to foreland in-sequence thrusting . . . . .	117
44. Schematic sequential diagram showing the emplacement of the Buffalo Mountain sheet, the Holston Mountain sheet, the Limestone Cove duplex, and the Pulaski sheet . . . . .	119
45. Sequence of imbrication at the leading edge of a thrust sheet; 1 = oldest, 4 = youngest . . . . .	122
46. Sequence of imbrication at the trailing edge of a thrust sheet; 1 = oldest, 4 = youngest . . . . .	122

LIST OF PLATES

PLATE	PAGE
1. Geologic map and structural sections of Buffalo Mountain, Tennessee . . . . .	in pocket



## CHAPTER I

### INTRODUCTION

#### Purpose and Scope of Study

This thesis is concerned with the structural geology and deformational history of part of the frontal margin of the Blue Ridge structural province in northeast Tennessee. Specifically three problems will be addressed:

1. How many generations of thrust faulting have affected this region?

2. In what sequence were the major thrust sheets emplaced?

3. In what sequence did the northwestern end of the Buffalo Mountain thrust sheet imbricate?

Previous work by King et al., (1944), Ordway (1949, 1959), King and Ferguson (1960), Bearce (1966, 1969), Rodgers (1970), Roeder et al., (1978b), Keller (1980), Boyer and Elliott (1982), and Diegel (in press, a and b) suggests that either one or several generations of thrust faulting have affected this region. Critical tests necessary to solve this structural problem are:

1. Direct and indirect examination of thrust faults to determine the angular relationships between the thrust plane, hanging wall strata, and foot wall strata;

2. Examination of age relationships between hanging wall and foot wall strata across thrust faults;

3. Examination of fault trace patterns (in map scale) to determine the presence of crosscutting relationships.

In addition to the uncertainty about the number of thrust generations affecting the front of the Blue Ridge in northeast Tennessee, argument exists concerning the sequence of thrust sheet emplacement. One idea is that thrusts are emplaced sequentially from the hinterland to the foreland (Gwinn, 1964, 1970; Bally et al., 1966; Dahlstrom, 1970). An alternative idea is that thrust faults are emplaced in a foreland to hinterland, or "break-back" fashion (Milici, 1975; Harris and Milici, 1977). In order to determine the sequence of thrust emplacement in the Buffalo Mountain and northeast Tennessee area three relationships were examined. These are:

1. Age relationships between hanging wall and foot wall rocks around thrust faults;

2. Map pattern relationships between thrust fault traces;

3. Geometry or orientation of thrust sheets with respect to each other.

Imbrication within a single thrust sheet can proceed either from hinterland to foreland or from foreland to hinterland. To determine the sequence of imbrication in the Buffalo Mountain thrust sheet, mesoscopic and

microscopic deformational fabrics around the imbricate thrust faults and within the imbricate thrust sheets are examined.

### Location and Geography of Study Area

Buffalo Mountain is located approximately 70 miles northeast of Knoxville, Tennessee along the western margin of the Blue Ridge structural province (see Figure 1). Specifically, the field area is located in the southwestern end of Buffalo Mountain in Unicoi and Washington counties Tennessee. The field area is bounded to the northwest and southeast by the Buffalo Mountain thrust, to the southwest by the Nolichucky River and to the northeast by Whaley Brook.

In addition to detailed work on the southwestern end of Buffalo Mountain, regional structural characteristics of the rest of Buffalo Mountain and the southwestern extension of the Buffalo Mountain thrust sheet are examined. This area has been previously interpreted to contain thrust faults that cut down stratigraphic section and place younger rocks over older rocks (Ordway, 1949, 1960; Bearce, 1966, 1969). The best rock exposures are present within the gorge of the Nolichucky River, along the numerous

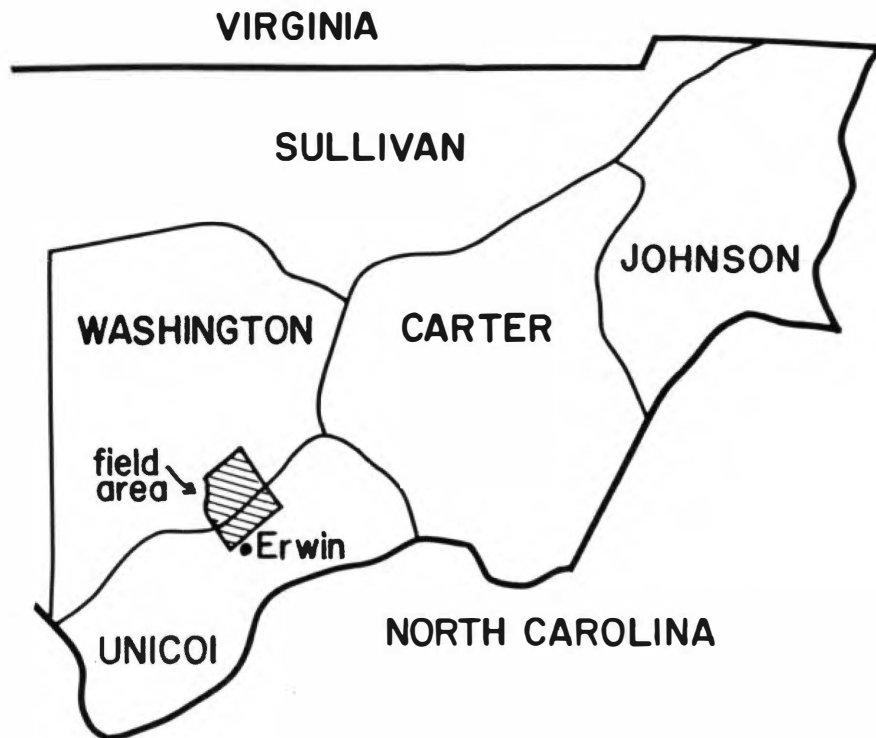

Figure 1. Location map of field area. The Buffalo Mountain area is located along the western margin of the Blue Ridge structural province. Specifically, the field area is located in Unicoi and Washington counties.

streams that cross the field area, and at several road cuts within the study area.

### Previous Investigations

Initial reconnaissance mapping of the state by J. M. Safford (1856, 1869) served as a guide to the region until the more detailed work of Keith (1899, 1903, 1907). During the first quarter of this century, most of the work in northeast Tennessee concerned the occurrence and distribution of mineral deposits such as iron ore (Jarvis, 1912), bauxite (Purdue, 1914), phosphate (Jenkins, 1916) and manganese (Stose and Schrader, 1923). The problems of stratigraphy and structure in the region were initially discussed by Barrell (1925), Jonas and Stose (1939), Laurence (1939), and Butts (1940).

The first work outlining regional structure and stratigraphy was by King, Ferguson, Craig, and Rodgers (1944). These geologists recognized that the Holston Mountain, Iron Mountain, and Stone Mountain faults are part of a single thrust surface. Later work by King and Ferguson (1960) and Bryant and Reed (1970) showed the structure of northeastern Tennessee and northwestern North Carolina in greater detail. The map and explanatory text

of Rodgers (1953) still serves as the best regional guide to the geology of east Tennessee.

Several geologists have commented on the evolution of structures in the southern Blue Ridge (see Figure 2). King and Ferguson (1960) presented a single thrust-episode model of thrust sheets emplaced in a foreland to hinterland fashion. King (1964), Hamilton (1961), and Rodgers (1970) suggested that two episodes of thrusting are responsible for structures found southwest of the field area. Roeder et al., (1978a) argued that the southern Appalachians have undergone several periods of deformation. Hatcher (1978) suggested that thrust sheet emplacement occurred in a hinterland to foreland fashion during two separate deformational episodes. Boyer and Elliott (1982) and Diegel (in press, b) proposed that the overall kinematic development of the western margin of the Blue Ridge appears to be similar to the Valley and Ridge; the thrusts contain ramp and flat trajectories and were emplaced in a hinterland to foreland progression with younger more external sheets folding the older more internal sheets.

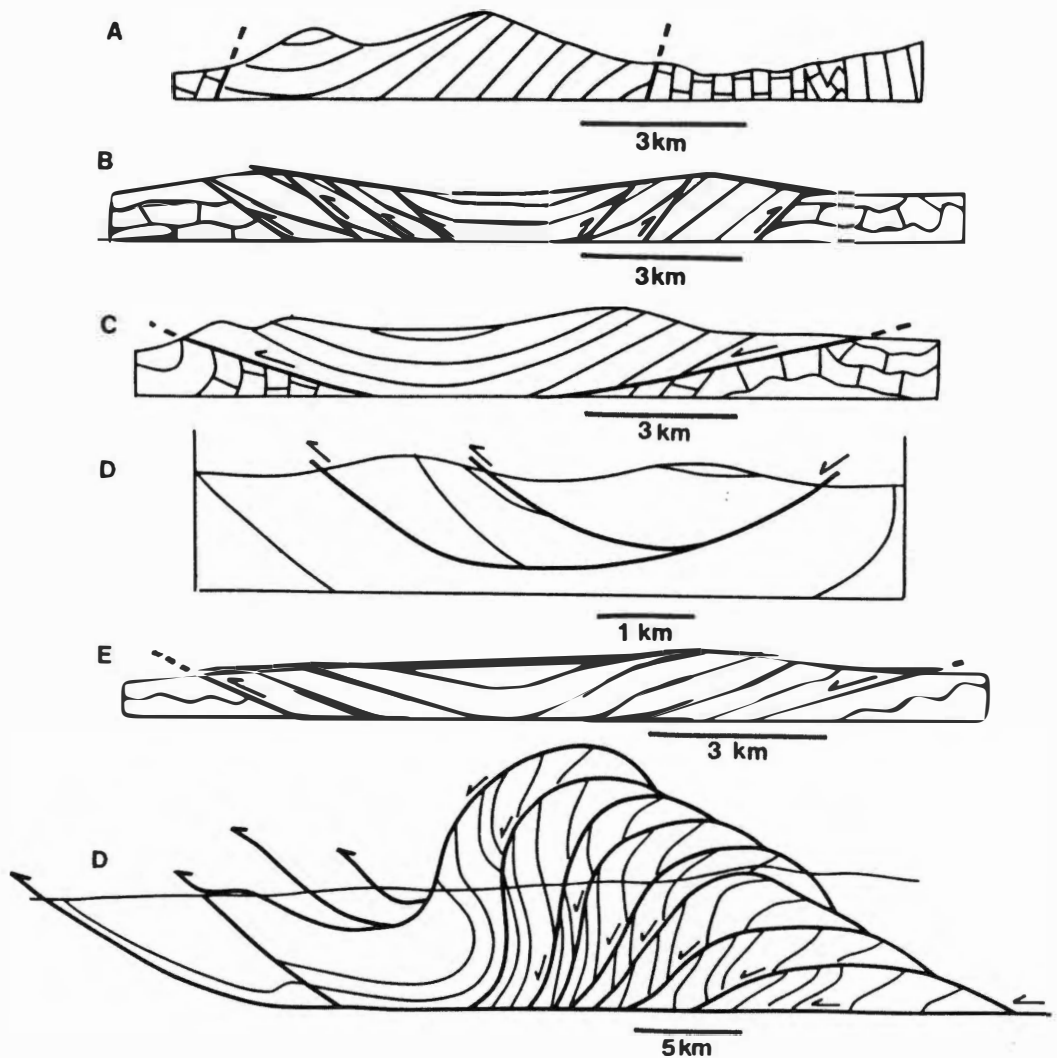

Figure 2. Successive interpretations of structure in northeast Tennessee. (A) Safford, 1896, (B) Keith, 1907, (C) Butts, 1932, (D) Ordway, 1949, 1959, (E) King and Ferguson, 1960, and (F) Diegel, in press a and b.

## CHAPTER II

### THRUST GEOMETRIES

#### Introduction

Willis (1891) first proposed thrust faulting in the Southern Appalachians to explain the positioning of older metasedimentary (Ocoee) rocks over younger carbonate (Knox) rocks at Cades Cove, Tennessee. Keith (1902) suggested that the "superpositioning of Archean (Precambrian) granite on Cambrian (Chilhowee ?) sediments" along brecciated planes occurred as a result of thrusting in the Southern Appalachians.

Present ideas, assumptions, and methods of study concerning fold and thrust belts are primarily a product of field studies and petroleum exploration in the Appalachians, the Wyoming Rockies, and the well-exposed Canadian Rockies. Excellent reviews by Rich (1934), Bally et al., (1966), Dahlstrom (1969, 1970, 1977), Royse et al., (1975), Elliott (1976, 1977), Boyer and Elliott (1982), Price (1981), Perry, Roeder, and Lageson (1984), and Woodward, Boyer, and Suppe (1985) serve as guides to fold and thrust belt study.



## Definitions and Assumptions

A thrust fault is a map-scale surface of contractional displacement with no reference to dip or amount of displacement (Dennis, 1981). Thrust faults usually place older rocks over younger rocks with the overlying rock occurring in the hanging wall and the underlying rock in the foot wall (see Figure 3). A thrust sheet is the tectonic unit that overlies a thrust fault and is named after the underlying thrust, (Boyer and Elliott, 1982).

Thrust faults usually cut up stratigraphic section in the direction of tectonic transport causing vertical thickening and lateral shortening of stratigraphic sequences (see Figure 3), (Dahlstrom, 1970, p. 342). Thrusts characteristically have a staircase trajectory (Rich, 1934) with the steep sections of the thrust surface termed ramps, and the gentle portions termed flats (Douglas, 1950).

Ramps and flats occur in both the foot wall and hanging wall. Understanding the relationship between foot wall and hanging wall structure is essential in understanding the three-dimensional geometry of a thrust fault (see Figure 4). Four ramp-flat relationships are seen in thrust terranes: hanging wall flat on foot wall flat; hanging wall flat on foot wall ramp; hanging wall ramp on foot wall flat; hanging wall ramp on foot wall ramp

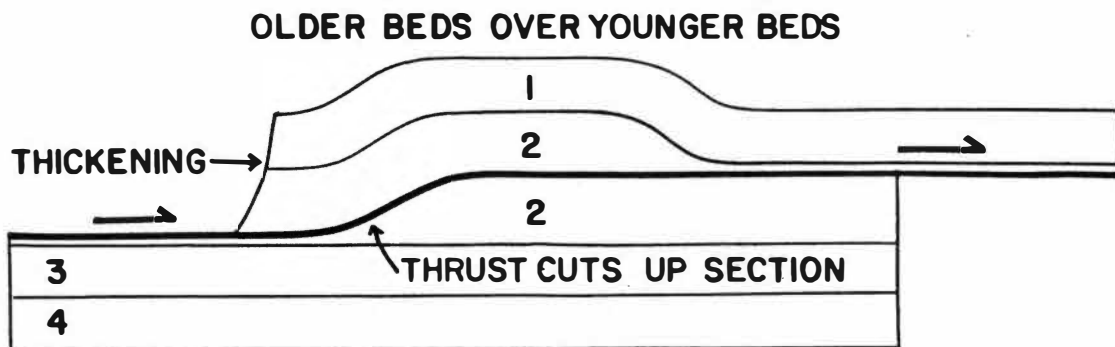

Figure 3. The ideal thrust fault. The thrust cuts up section in the direction of tectonic transport, places older beds over younger beds, and thickens the section. (from Dahlstrom, 1970).

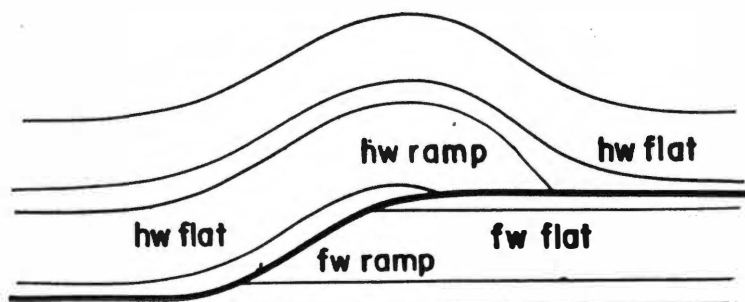

Figure 4. Relationship between ramps and flats in a thrust sequence. Four ramp flat relationships are possible: hanging wall flat on foot wall flat; hanging wall flat on foot wall ramp; hanging wall ramp on foot wall flat; hanging wall ramp on foot wall ramp. (from Woodward, Boyer, and Suppe, 1985).

(Woodward, Boyer, and Suppe, 1985, p. 5). Stratigraphic cutoff lines (Douglas, 1958; Dahlstrom, 1970; King and Ferguson, 1960), formed by the intersection of a thrust surface with a stratigraphic horizon, provide an excellent way to identify ramps and flats (see Figure 5). Ramps are identified by closely spaced cutoff lines, and flats are defined by widely spaced cutoff lines.

Thrust surfaces characteristically flatten and merge at depth with a basal detachment or decollement to produce a listric shape. This feature was first recognized in the Rockies by Bally, et al., (1966). Regional cross-sections of the Appalachians (Gwinn, 1964; Roeder et al., 1978b; Woodward, 1985) also depict thrusts flattening at depth and merging with a basal decollement.

Branch lines (see Figure 5) are formed by the intersection of two fault surfaces (Elliott and Johnson, 1980). Trailing branch lines represent thrusts that have imbricated off of another thrust. Leading branch lines form when an imbricate thrust rejoins the original thrust to form a horse, (Diegel, in press). Branch line maps provide an excellent representation of the three dimensional geometry of thrust sheets.

A pod or section of rock completely bound by fault surfaces is known as a horse (see Figure 5), (Boyer and Elliott, 1982). By definition, horses contain both trailing and leading branch lines (Boyer and Elliott,

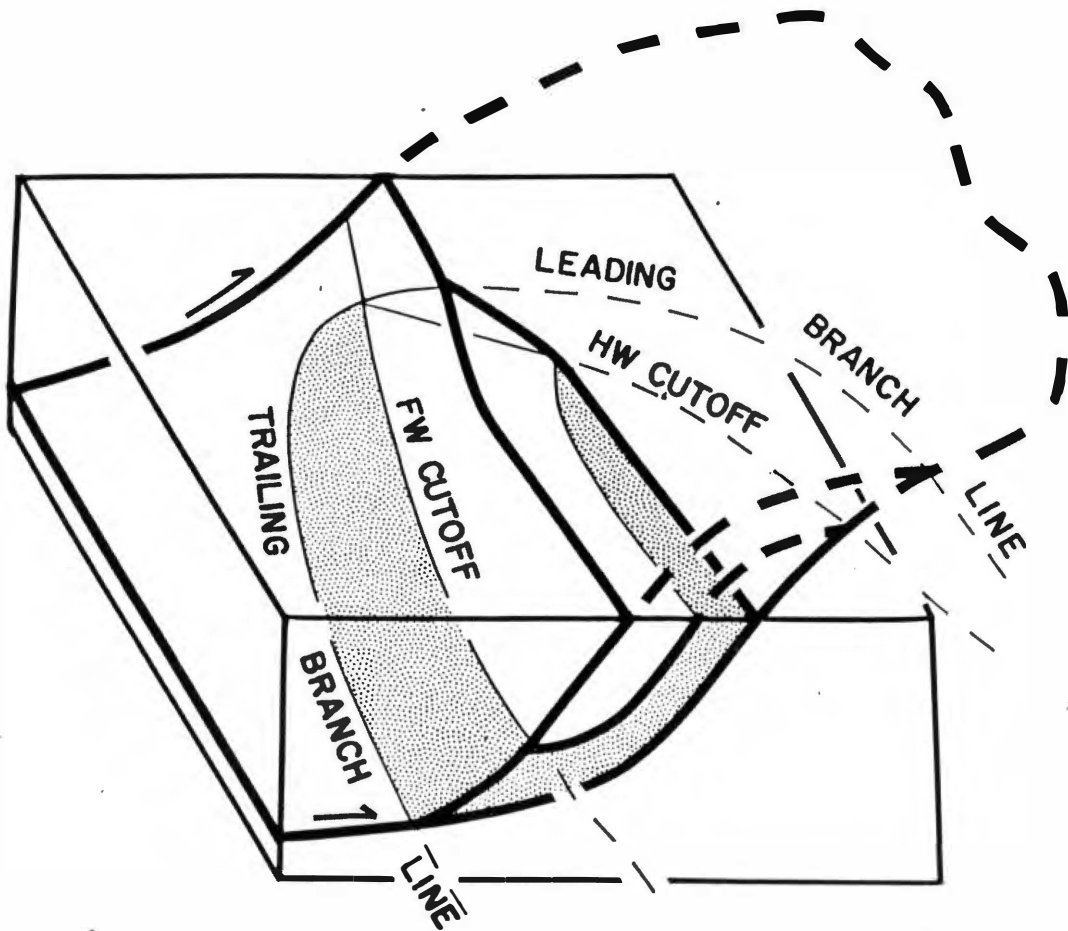

Figure 5. Block diagram of a horse illustrating leading and trailing branch lines and hanging wall and foot wall cutoff lines. (from Diegel, in press a and b).

1982). Horses can be cut from either the hanging wall or the foot wall of a thrust, and frequently decorate the edges of major thrusts.

### Thrust Systems

A thrust system is a group of thrusts that join up or that are closely related to each other (Rodgers, 1953).

Thrust systems are subdivided into two broad types: imbricate fans and duplexes (Figure 6).

In an imbricate fan each sheet is a triangular-shaped slice separated by a listric thrust that merges into a lower common sole thrust (Boyer and Elliott, 1982, p. 1198). Two types of imbricate fans are recognized: a leading imbricate fan, in which maximum slip occurs along the leading or foreland thrust; and a trailing imbricate fan, in which maximum slip occurs in the trailing or hindward thrust (see Figure 6).

A duplex is composed of a series or "herd" of horses that are bound by an overlying roof thrust and an underlying floor thrust (Boyer and Elliott, 1982). Erosion through a typical duplex reveals an eyelid window (Sander, 1921; Oriel, 1950) composed of subsidiary faults that join the roof thrust at the window margin. Horses within duplexes characteristically have a parallelogram shape with

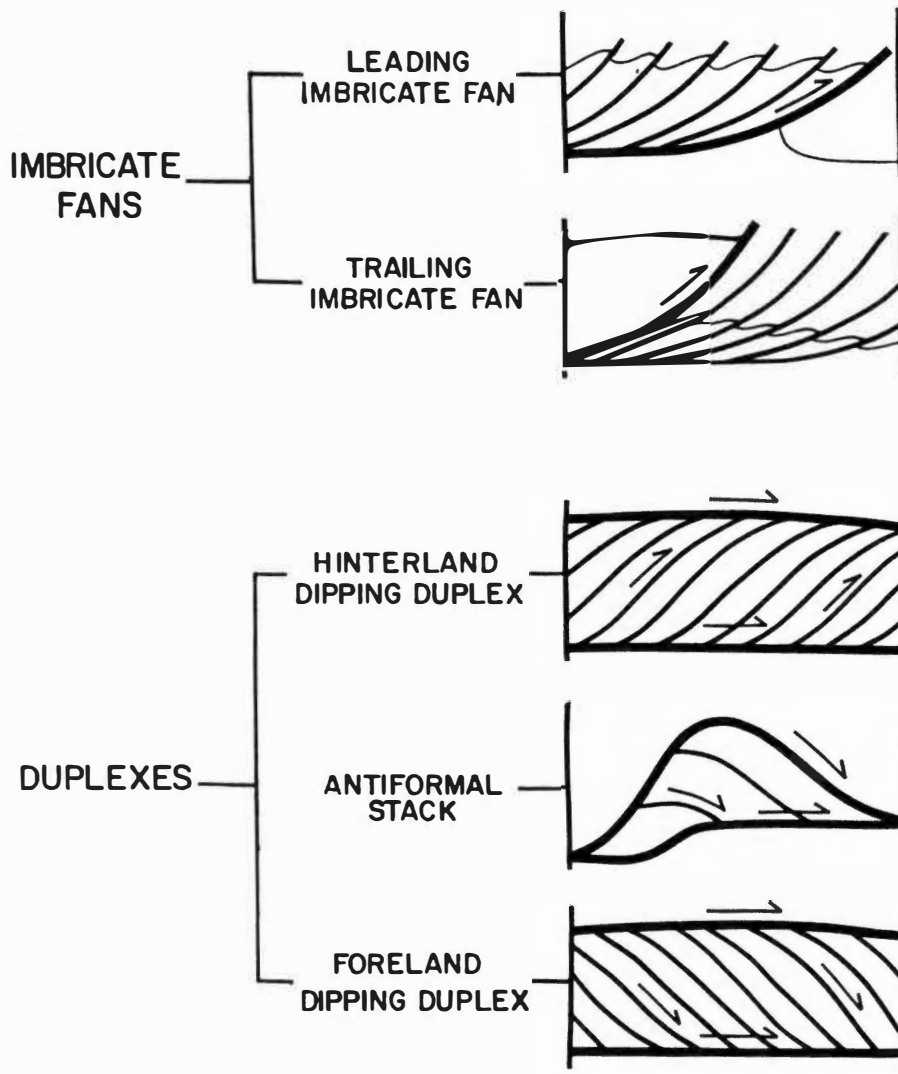

Figure 6. Classification of thrust systems. Imbricate fans are composed of overlapping thrust sheets that are separated by listric shaped thrusts. Duplexes are composed of a series or a "herd" of horses. A duplex is bounded by an overlying roof thrust and an underlying floor thrust. (from Boyer and Elliott, 1982).

bedding outlining an elongate anticline-syncline fold pair (see Figure 7). Structures, such as cleavage, within the horses usually have a forward structural facing (Shackleton, 1958).

Three types of duplexes are recognized: a hinterland dipping duplex; an antiformal stack; and a foreland dipping duplex. Hinterland dipping duplexes (see Figure 6) result when each horse within the duplex slips less than its own length, branch lines are arranged so that in each horse the trailing branch line is hindward to the leading branch line. Hinterland dipping duplexes usually consist of upwards-facing horses. Antiformal stacks (see Figure 6) form when each horse slips a distance that is equal to its length, branch lines become bunched up and the horses lie on top of each other. Foreland dipping duplexes (see Figure 6) result when each horse within the duplex slips farther than its own length, branch lines are arranged so that in each horse the trailing branch line is foreland to the leading branch line. Foreland dipping duplexes are usually composed of downwards-facing horses.

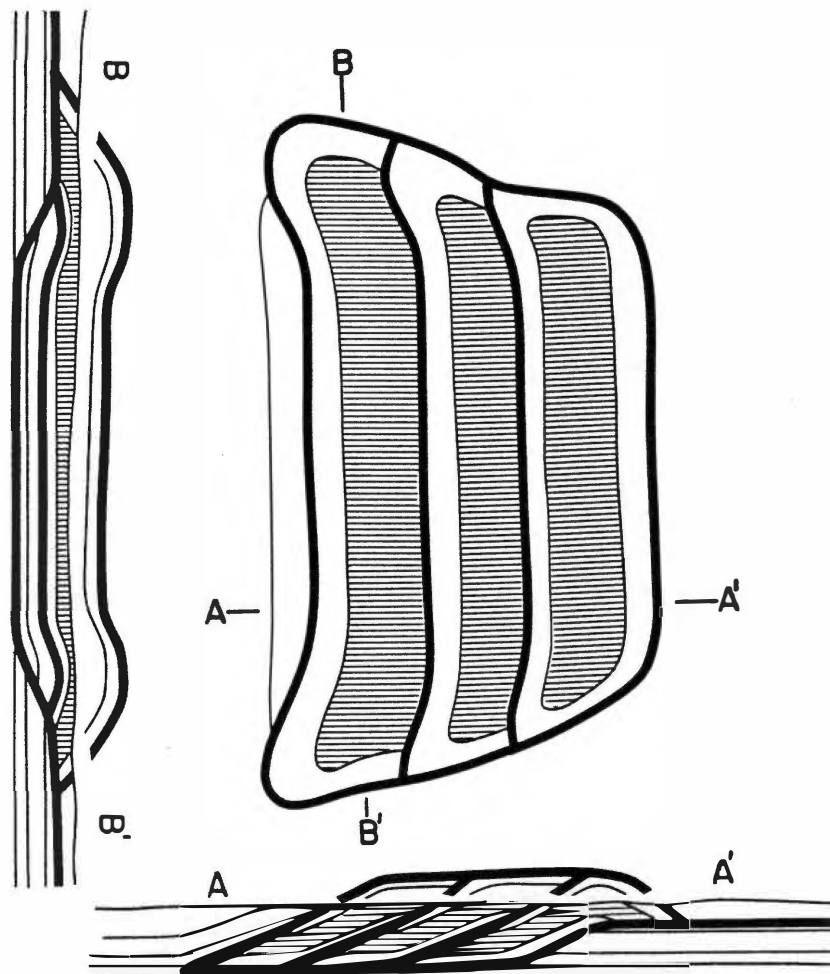

Figure 7. Characteristic map pattern and cross-section of hindward dipping duplex culmination. Map pattern reveals an eyelid window composed of subsidiary faults that join the roof thrust at the window margin. Cross-section shows the fold crests within the hindward dipping horses paralleling the subsidiary faults. (Boyer and Elliott, 1982).



## CHAPTER III

### STRATIGRAPHY

#### Introduction

The rocks of the Buffalo Mountain area consist of a sequence of sedimentary strata of Early Paleozoic age (see Figure 8). The oldest rocks of the sequence are the Lower Cambrian Chilhowee Group clastics. The Chilhowee Group is divided into three formations: the lower Unicoi Formation, the middle Hampton Formation, and the upper Erwin Formation. Overlying the Chilhowee Group in ascending stratigraphic order are the Middle Cambrian Shady Dolomite and Rome Formation, the Upper Cambrian Honaker Dolomite and Nolichucky Shale, and the Cambro-Ordovician carbonates of the Knox Group. The Chilhowee and Shady are found in the hanging wall of the Buffalo Mountain thrust, and form the elevated mass of Buffalo Mountain. The Honaker and Knox are found in the foot wall of the Buffalo Mountain thrust, and form the valleys surrounding Buffalo Mountain.

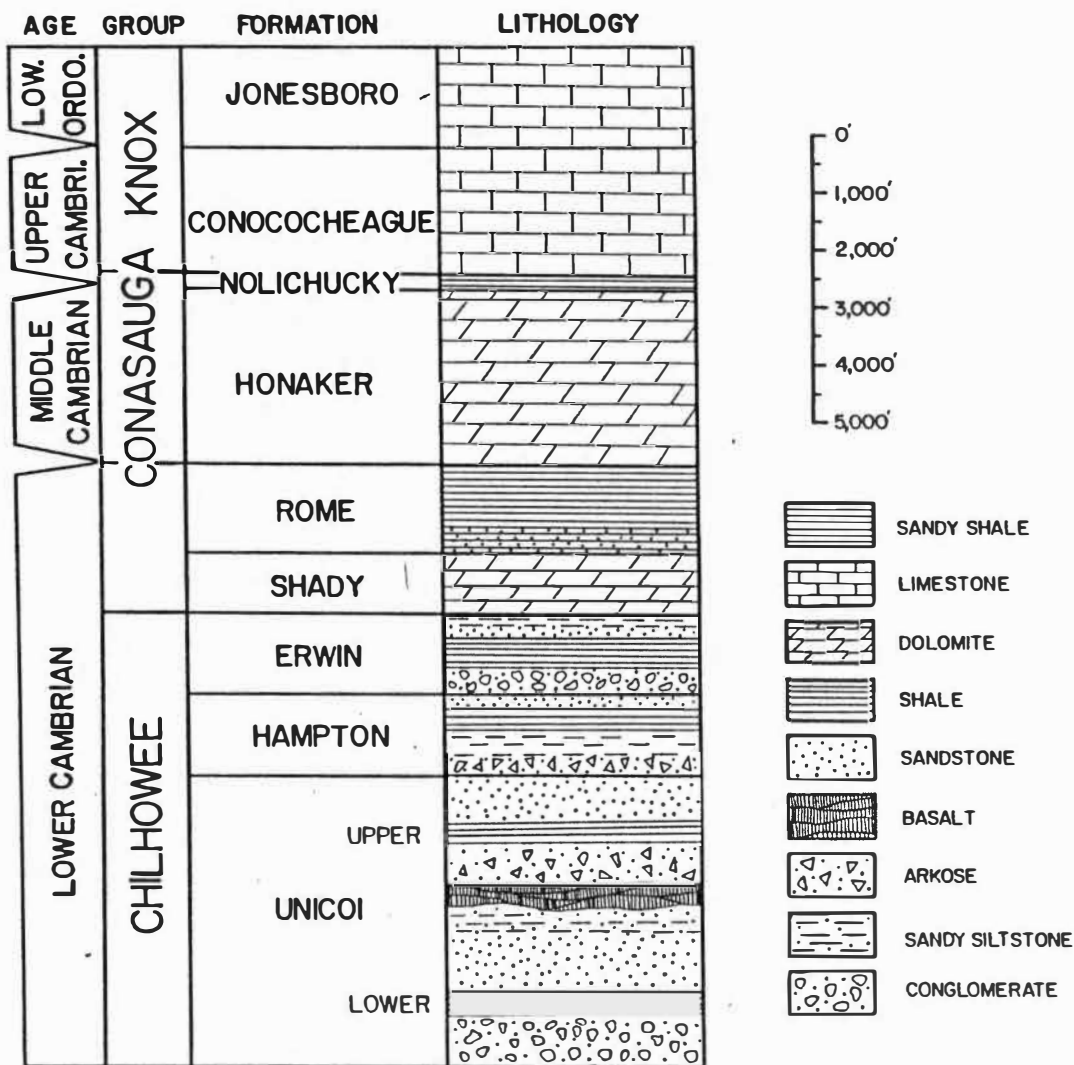

Figure 8. Generalized stratigraphic column of the Buffalo Mountain area. (from King et al., 1944; Rodgers, 1953; King and Ferguson, 1960).

## Chilhowee Group

The Chilhowee Sandstone was named by Safford (1856, 1869) for exposures along Chilhowee Mountain, Tennessee. Keith (1903, 1907) introduced and applied the terms Unicoi Formation, Hampton Shale, and Erwin Quartzite to sections of strata that he felt were uniform over a considerable area in northeast Tennessee. Further study (Barrell, 1925; Resser, 1938; Butts, 1940; Stose and Stose, 1944; and King et al., 1944) suggested that lithologic boundaries between formations are inconsistent, and that, because of interbedding, no single rock type dominates in any of the formations. King et al., (1944) redefined the Chilhowee into the Unicoi, Hampton, and Erwin formations using key widely traceable beds or groups of beds as formational boundaries.

The Chilhowee Group is composed of clastic rocks that lie unconformably above the Cranberry Gneiss basement. Each formation within the group is interbedded with varying rock types such as shale, siltstone, feldspathic sandstone, quartzose sandstone and pebble conglomerate. In a general sense the sequence becomes finer grained upward and there is an upward decrease in the amount of feldspar present (King and Ferguson, 1960, p. 33).

King and Ferguson (1960) and Harris (1979) showed that when the arrangement of stratigraphic sections before

thrusting is restored, the southeastern deposits are generally thicker and more shaly than the sandier northwestern sections (see Figure 9). This characteristic is especially evident in the lower Unicoi Formation. In addition, the pre-thrust arrangement of facies sections indicates that the northwestern sections lack the basaltic lavas that are characteristic of the southeastern sections.

The maximum thickness of the Chilhowee Group is 2,500 meters (7,500 feet) measured along Iron Mountain. Within northeast Tennessee 1,300 meters (4,000 feet) is the average thickness of the Chilhowee (King and Ferguson, 1960). Ordway (1949, 1959) concluded that the Chilhowee Group has a thickness approaching 2,700 meters (8,000 feet) in the Buffalo Mountain area.

Schwab (1972) summarized the depositional environment of the Chilhowee as a series of fluvial and nearshore sandstones that interfinger to the east with deeper water shales and siltstones. In addition, Schwab (1972) indicates that as the sea transgressed westward, the character of the sandstone changed upward from arkosic and conglomeratic sandstone to orthoquartzite. Cudzil (1985), working a few kilometers northeast of Buffalo Mountain, concluded that the Chilhowee represented an overall deepening from terrestrial environments of deposition to a marine shoreface and then to a storm shelf environment.

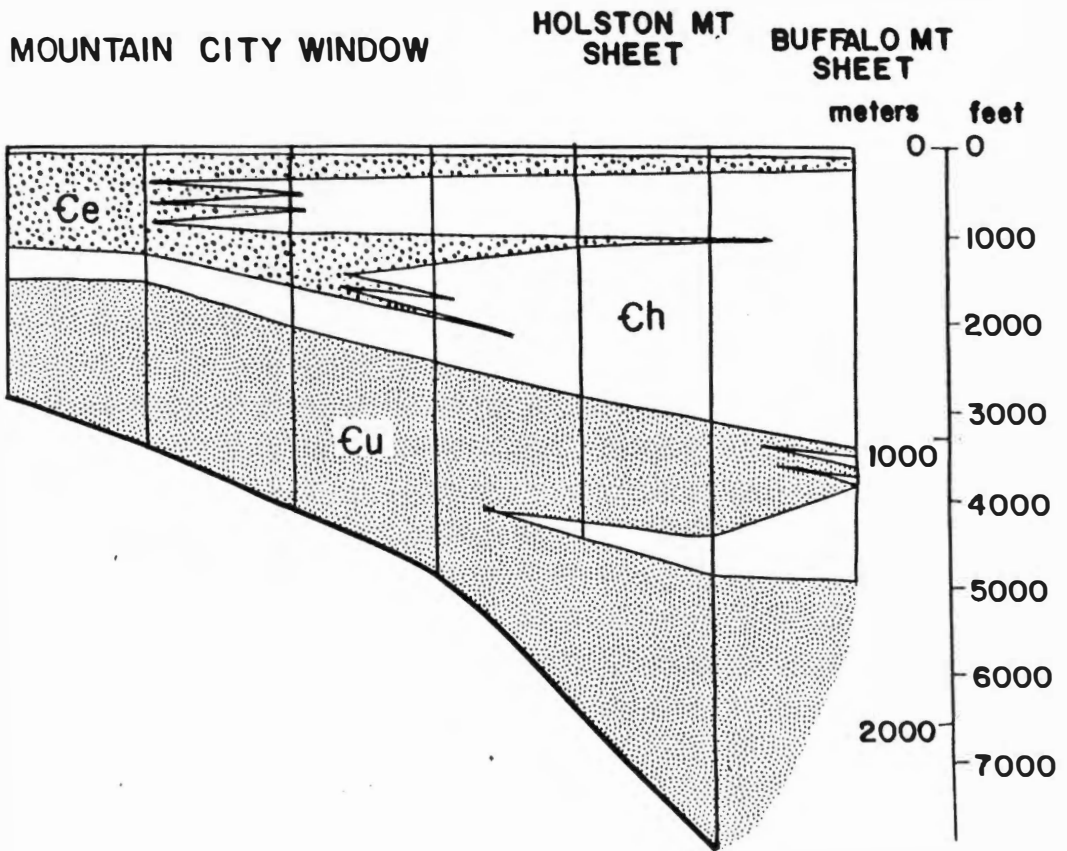

Figure 9. Restored depositional model for the Chilhowee Group in northeast Tennessee. The model shows a general southwest thickening of facies which is especially evident in the Unicoi Formation. (from Harris, 1979).

## Unicoi Formation

The Unicoi Formation is mainly composed of arkosic, conglomeratic and coarse-grained sandstone. The Unicoi also contains beds of vitreous quartzite, shale, and occasionally amygdaloidal basalt. The Unicoi thins westward from 1,700 meters (5,000 feet) along Iron Mountain to 700 meters (2,000 feet) on Holston Mountain. Generally, it is divided into an upper and lower member. The contact between these members is defined by the presence of amygdaloidal basalt.

The Unicoi Formation exposed at Buffalo Mountain is similar in character to other exposures in northeast Tennessee. The upper division of the Unicoi outcrops along Ashhopper Hollow, Harris Brook, Whaley Brook (name changed to Pippin Hollow), Indian Creek, and northwest of Millstone Creek (see Plate 1). Although clastic rocks from shale to conglomerate are present, the most characteristic rock types are thick-bedded, coarse-grained feldspathic quartzite, silty sandstone, siltstone interbedded with shale and amygdaloidal basalt. The beds typically form resistant ledges.

Ordway (1949, 1959) selected a ridge-forming, feldspathic, vitreous-white (N 9, all color names and corresponding numbers are from Goddard et al., 1980) quartzite layer as the top of the Unicoi Formation. This

quartzite layer can be easily seen from TN 81 S/107 E near Millstone Creek and along TN 106 near Warm Cove (see Plate 1). The thickness of the upper member of the Unicoi Formation is estimated to be 800 meters (2,500 feet).

The basalt layers occur as fine-grained, dark yellowish green (10 GY 4/4), amygdaloidal, lenticular, discontinuous bodies up to 50 meters (150 feet) thick. Within the field area, basalt exposures are found along the south side of Ashhopper Hollow, northeast of the mouth of Whaley Brook (Pippin Hollow), and in Canah Gap.

The lower member of the Unicoi formation is exposed along the Nolichucky River south of Stony Point, and consists of fine- to medium-grained, cross-bedded, feldspathic quartzite interbedded with red to brown shale. The rocks are generally thinly-bedded with few ledge forming layers. The thickness of the lower member of the Unicoi and the total thickness of the Unicoi in the Buffalo Mountain area is unknown since the base of the formation has been removed by thrust faulting. A minimum thickness, however, is estimated to be 585 meters (1,750 feet).

### Hampton Formation

The Hampton formation is composed of interbedded units of claystone, shale, siltstone, arkosic sandstone, and

vitreous quartzite. The Hampton Formation possesses no consistent sequence of units on a regional scale.

At Buffalo Mountain, the Hampton Formation occupies much of the study area extending from The Horseshoe of the Nolichucky River northeast nearly to Warm Cove, and south-southwest to Stony Point (see Plate 1). The formation is composed mostly of shale, sandy or silty shale and sandstone interbedded with medium to fine-grained vitreous quartzite. The quartzite units of the Hampton are generally less massive than the quartzite of the Erwin Formation and less feldspathic than the quartzite units of the Unicoi. In addition, the quartzite beds of the Hampton Formation gradually grade upward to thin beds of sandy or silty shale. Cross-beds are well displayed in exposures at Shinbone Rock and along the Nolichucky River north of Jump Hill. The Hampton is calculated to be approximately 1,000 meters (3,000 feet) thick.

#### Erwin Formation

The Erwin Formation typically consists of interbedded white (N 9) vitreous quartzite, dark ferruginous quartzite, green siltstone and shale. Within the field area, the Erwin extends north-northeast from Stony Point to just northeast of the head of Deacon Creek. Four units of the Erwin are recognized in the field area. A lower quartzite unit is



composed of either one or two medium-to-coarse-grained vitreous white (N 9) quartzite subunits with well rounded grains. The lower quartzite unit is about 40 meters (125 feet) thick. A fine-grained clastic unit above the lower quartzite unit is about 215 meters (650 feet) thick, and is composed of light olive brown (5 Y 5/6) to moderate red (5 R 4/6), thinly-bedded, sandy or silty shale and siltstone. An upper quartzite unit is characterized by two 6 to 10 meter (20 to 30 foot) thick, thickly-bedded, medium-grained, vitreous-white (N 9) quartzite subunits. The two quartzite units are separated by about 210 meters (625 feet) of moderate reddish brown (10 r 4/6), thinly bedded, siltstone, silty shale, and shale. The uppermost unit of the Erwin, the Helenmode, is dark yellowish orange (10 YR 6/6) to moderate brown (5 YR 4/4), finely bedded claystones, shales and sandstones. The top of the Helenmode is removed by thrust faulting.

### Shady Dolomite

The Shady Dolomite was named by Keith (1903) for Shady Valley, Tennessee. Generally, the Shady consists of dolostone interbedded with occasional layers of limestone. Several well defined rock types have been recognized either as mappable members of the formation (Currier, 1935, p. 16;

Butts, 1940, p. 41), or as interfingering units or bodies (Rodgers, 1948, p. 4, 8). The Shady Dolomite is between 315 and 360 meters (950 and 1,150 feet).

Within the field area, the Shady Dolomite crops out in Canah Hollow. Five rock types are recognized in the field (Ordway, 1949, 1959 recognized only four). From bottom to top the units are: the lower blue unit; the ribboned unit; the middle blue unit; the upper white unit; and the upper blue unit. Due to structural complexities, it is difficult to interpret the three-dimensional stratigraphic relationships of the Shady.

The lower blue member is 30 meters (100 feet) thick and is a pale blue (5 B 6/2), thickly-bedded to massive, coarsely-crystalline dolostone. The ribboned unit typically consists of medium-grained to coarse-grained medume bluish gray (5 B 5/1) dolostone with bands or stringers of bluish white (5 B 9/1) and pinkish gray (5 YR 8/1) coarsely-crystalline dolostone, and occasionally limestone. The ribboned member is estimated to be 70 meters (225 feet) thick. The middle blue unit is composed of light bluish gray (5 B 7/1) to Dusky blue (5 PB 3/2), thickly-bedded, massive dolostone with occasional nodules of chert. The middle blue unit is 80 meters (250 feet) thick. The upper white unit is 50 meters (150 feet) thick and consists of bluish white (5 B 9/1) to very light gray (N 8), massive, largely saccharoidal to compact dolostone.

The upper blue unit is composed of light bluish gray (5 B 7/1) to medium bluish gray (5 B 5/1), medium-to-thinly bedded, well-laminated dolostone with occasional nodules or lenses of light gray (N 7) to medium bluish gray (5 B 5/1) chert. The upper blue unit is at least 50 meters (150 feet) thick.

### Rome Formation

The Rome Formation was defined by Hayes (1891) and Walcott (1891) for exposures near Rome, Georgia. In northeast Tennessee the Rome is a red, maroon, or brown, silty and well consolidated shale (King and Ferguson, 1960). Maroon-red and greenish-brown siltstone often grades into fine-grained sandstone. The fine-grained sandstone also interbeds with the shale. The Rome Formation is not exposed in the Buffalo Mountain area.

### Conasauga Group

The Conasauga Group was named for the Conasauga River in Whitfield and Murray Counties, Georgia (Hayes, 1891; Walcott, 1891). Rodgers (1953) identified three phases or subdivisions in the Conasauga based on regional stratigraphic change. The phases are: a northwestern

phase consisting largely of shale, a central phase of alternating shale and carbonates, and a southeastern phase principally of dolostone but including some limestone and a little shale. Within the field area only one formation of the southeastern phase, the Honaker Dolomite, crops out.

### Honaker Dolomite

The Honaker Dolomite was named by Campbell (1897, p. 2) for the town of Honaker, Virginia. In northeast Tennessee, the characteristics of the Honaker are highly variable. The lower portion of the formation is mainly massive to laminated dolostone, with some shale. The middle to upper portion of the formation consists of slabby light-gray dolostone or limestone with argillaceous ribbons and shaly partings, (King and Ferguson, 1960, p. 54). Within the field area, the Honaker crops out just northwest of Erwin, Tennessee and is a medium bluish gray (5 B 5/1), fine-grained dolostone with numerous thin moderate yellowish brown (10 YR 5/4) silty lamina that show up on weathered surfaces.

## Knox Group

Safford (1869) named the Knox Group for exposures along Second Creek in Knoxville, Tennessee. As with the Conasauga Group, the Knox displays variable lithologic characteristics across east Tennessee and can be subdivided into a northwestern dolostone phase and a southeastern limestone phase.

The exposures of Knox group in the Buffalo Mountain area are part of the southeastern limestone phase. The southeastern phase consists of the Conococheague Limestone and the overlying Jonesboro Limestone. The Conococheague typically consists of dark blue-gray limestone with thin silty dolostone partings that form characteristic "ribbons". Chert is present in the Conococheague as dark nodules. The Jonesboro is a dark blue-weathering limestone that often contains beds of massive, internally laminated dolostone. Occasionally it is "ribbed" but generally it is pure and massive; chert is rare in the Jonesboro limestone (Rodgers, 1953).

The only outcrop of Knox in the field area is located in the footwall of the Buffalo Mountain thrust fault along the Nolichucky River north of Jump Hill. The Knox there is pale blue (5 B 6/2) to medium bluish gray (5 B 5/1), medium-grained, massive limestone. Chert is present as very light gray (N 8) to bluish white (5 B 9/1) nodules and

as distinct layers or horizons. Because of the presence of abundant chert, this exposure is identified as the Conococheague Limestone.

## CHAPTER IV

### REGIONAL STRUCTURE

#### Introduction

Buffalo Mountain is located along the western margin or transitional zone of the Blue Ridge structural province. The Blue Ridge structural province is a belt of allochthonous igneous, metamorphic, and sedimentary rocks that have generally been folded into a north plunging anticlinorium that is often overturned to the northwest (Reed, 1970).

The western margin of the Blue Ridge in the Buffalo Mountain and northeast Tennessee area is characterized by northeast striking thrust sheets (see Figure 10). The largest of these is the Holston Mountain sheet, outlined by the traces of the Holston Mountain, Iron Mountain and Stone Mountain thrust faults. Within the Holston Mountain sheet, the Mountain City window exposes the hinterland dipping Doe Ridges duplex and the foreland dipping Limestone Cove duplex (Boyer and Elliott, 1982). The thrust sheet between the Iron Mountain and Holston Mountain thrust faults, is referred to as the Shady Valley thrust sheet. Thus, the Holston Mountain thrust connects with the Iron Mountain thrust beneath the Shady Valley thrust sheet and joins the

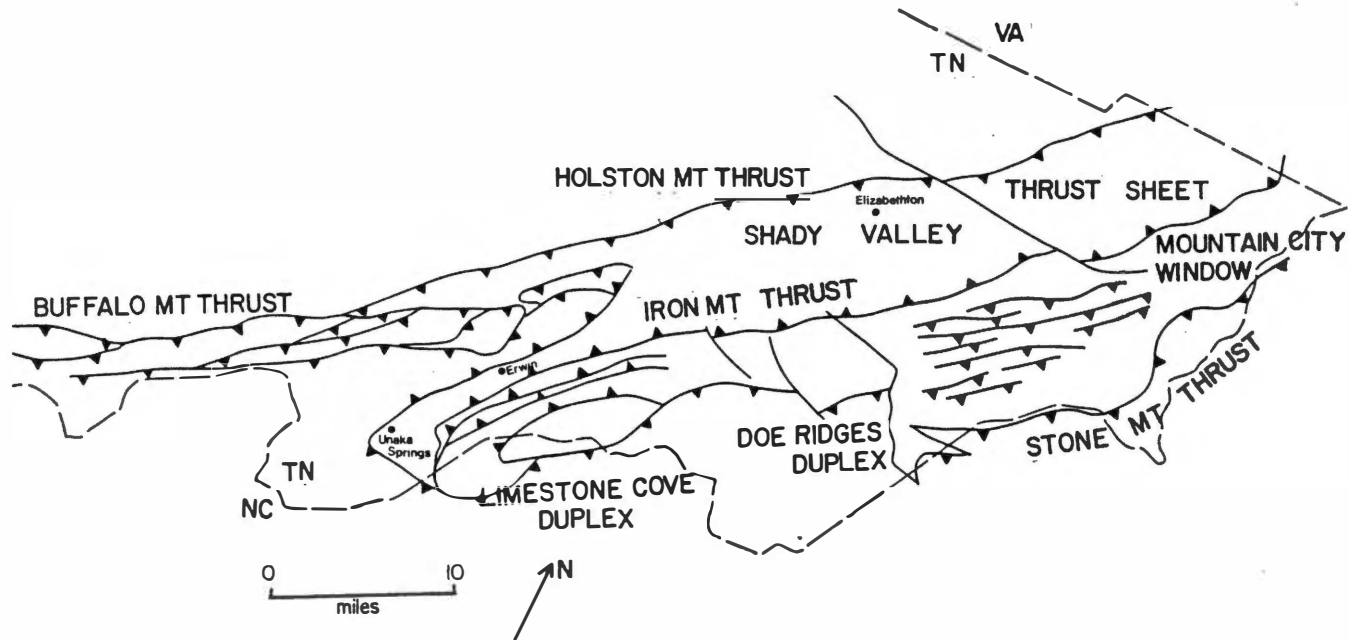

Figure 10. Regional structural map of the northeast Tennessee Blue Ridge. (from King et al., 1944; Rodgers, 1953, 1970; King and Ferguson, 1960; Boyer and Elliott, 1982)



Stone Mountain thrust over the Mountain City window (King et al., 1944; Rodgers, 1953, 1970; King and Ferguson, 1960).

### Holston Mountain Thrust Sheet

The Holston Mountain thrust places upper Unicoi clastics northwest over Knox Group carbonates of the Pulaski system (see Figure 10). North of Elizabethton, Tennessee the hanging wall of the Holston Mountain thrust "ramps up section laterally to the southwest across the Rome Formation and into the Conasauga Group" (Diegel and Wojtal, 1985, p. 101). The Holston Mountain thrust remains in the Conasauga Group until it merges with the Buffalo Mountain thrust at a lateral branch line seven miles west of Erwin, Tennessee (see Figure 10). The Iron Mountain fault can be traced from the Catface Mountain fault around the northeast end of the Mountain City window and southwest to near Erwin, where it merges with the Stone Mountain fault (Rodgers, 1970). The Iron Mountain fault places lower Unicoi and occasionally basement rocks over shales of the Rome and dolostones of the Shady. Along the Iron Mountain fault, many large subsidiary slices, or horse blocks occur (King and Ferguson, 1960). The Stone Mountain thrust fault forms the southeastern boarder of the Mountain

City window (see Figure 10). The Stone Mountain thrust generally puts basement rocks over rocks of the Chilhowee Group, and is broken occasionally by minor imbricates.

The Shady Valley thrust sheet contains a relatively undisturbed sequence of basement to Knox carbonates and is folded into the open Stony Creek synclinorium. The limbs of the synclinorium dip inward 20° to 50° with dips greatest along the Iron Mountain thrust.

#### Mountain City Window

The Mountain City window extends approximately 96 kilometers (60 miles) southwest from southern Virginia to just southwest of Unaka Springs, Tennessee. Most of the window contains rocks of the Rome Formation and Shady Dolomite. However, sections of the Chilhowee Group do crop out along the southeast boarder of the window, and in the Doe Ridges and Limestone Cove inner windows (King and Ferguson, 1960). The Mountain City window is divided into five structural units, (Diegal and Wojtal, 1985). From northeast to southwest they are: Catface sheet; Hampton sheet; Doe Ridges duplex; Stone Mountain slices; and Limestone Cove duplex.

The Catface sheet, located in the extreme northeastern segment of the Mountain City window (see Figure 10), is

composed of Precambrian Mount Rodgers Group volcanics which are thrust northwest over the Chilhowee Group clastics of the Hampton sheet. The Catface sheet is overlain to the southeast by the Stone Mountain sheet. The rocks of the northeastern Hampton sheet are folded into a homoclinal sequence that extends southwest from beneath the Catface sheet (King and Ferguson, 1960). Southeast of Mountain City, this sequence is overturned and thrust over the Rome Formation of the Doe Ridges duplex.

The Doe Ridges duplex is a hinterland dipping duplex (Boyer and Elliott, 1982; Diegel, in press, a and b) composed of a series of northeast striking, southeast dipping thrust faults that place rocks of the Erwin Formation over the Rome and Shady. The Doe Ridges duplex forms one of two culminations in the Mountain City window (Limestone Cove duplex is the other), (Diegal and Wojtal, 1985). The Doe Ridges duplex is overlain by the Iron Mountain thrust sheet to the northwest, the Stone Mountain thrust family to the southeast and the Hampton sheet to the southwest. Thus, the Doe Ridges duplex is exposed within an inner window of the Mountain City window.

The Stone Mountain fault family lies southeast of the Doe Ridges duplex. This fault family, like the Hampton sheet to the north, consists of a homoclinal sequence of Chilhowee group rocks that is thrust northwest over the Rome formation of the Doe Ridges duplex (King and Ferguson,

1960). However, this sequence is disturbed by folds and a series of branching thrust faults that generally dip to the southeast.

To the southwest, the Doe Ridges duplex terminates along the Unaka Mountain and Little Pond Mountain thrusts. The Little Pond Mountain thrust is a branch of the Stone Mountain fault and consistently thrusts basement rocks over the Rome of the Doe Ridges structure or over the basement and Chilhowee rocks of the Hampton sheet.

The rocks of the southwestern Hampton sheet form a northwestward dipping homocline similar to the Hampton sheet northeast of the Doe Ridges duplex. The southwestern end of the Hampton sheet is cutoff from the Limestone Cove structure by a series of "transcurrent faults, each with a considerable component of right-lateral strike-slip" (King and Ferguson, 1960, p. 75). These faults are clearly younger than the main episode of thrusting because they offset the Iron Mountain fault.

The Limestone Cove foreland dipping duplex (Boyer and Elliott, 1982; Diegel, in press, a and b) forms the southwestern culmination of the Mountain City window. The Limestone Cove duplex is composed of five nested windows. Each horse in the duplex dips to the foreland, with dip increasing to the northeast.

## Buffalo Mountain-Del Rio Thrust Pile

Northwest of the Limestone Cove duplex, the Mountain City window and Holston Mountain sheet are overlain by the Buffalo Mountain-Del Rio thrust pile (see Figure 10, page 32). The Buffalo Mountain-Del Rio thrust pile is composed of a sequence of Lower Cambrian Chilhowee and Precambrian Ocoee strata that has been repeated by a series of imbricate thrust faults. The pile is grossly folded into a northeast trending synclinal shape, with minor intervening warps within the individual imbricate sheets.

The northwestern end of the Buffalo Mountain thrust sheet (Buffalo Mountain area; field area of present study) is a tongue-shaped (Ordway, 1949, 1959) body of Chilhowee rocks. The sheet is broken by a series of imbricates into four minor sheets. Southwest of the Buffalo Mountain area, mapping by Bearce (1966, 1969) indicates that the Buffalo Mountain sheet contains both Chilhowee and Ocoee strata. The sheet is composed of approximately six minor imbricate sheets which are folded into elongate northeast trending synclines. Three of the more distinctive synclines are the Rich Mountain syncline, the Greene Mountain syncline, and the Paint Creek syncline. Work by Rodgers (1948) in the Bumpass Cove area also indicates the presence of an elongate northeast trending synclinal structure.

The Buffalo Mountain sheet thins to the southwest where it overlaps over the Del Rio thrust sheet (Bearce, 1969). The Del Rio sheet like the Buffalo Mountain sheet is composed of Chilhowee and Ocoee strata that has been disturbed by imbrication (Ferguson and Jewell, 1951). The Del Rio thrust sheet probably thins northwestward by wedging out from the base upward beneath the Buffalo Mountain sheet (Bearce, 1969).

Around the southwestern nose of the Mountain City window the Buffalo Mountain thrust probably merges with the Unaka Mountain fault. The Unaka Mountain fault brings up basement rocks over the Chilhowee of the Limestone Cove duplex. To the southwest the Unaka Mountain fault merges with the Devil Fork fault (Rodgers, 1953).

## CHAPTER V

### LOCAL STRUCTURAL GEOLOGY

#### Introduction

The Buffalo Mountain thrust fault stretches from the southwestern end of the Mountain City window northeast around the Buffalo Mountain area and then southeast where it merges into the Meadow Creek Mountain thrust (see Figure 10, page 32). Southeast of Embreeville, Tennessee, the Buffalo Mountain thrust replaces the Holston Mountain thrust as the front of the Blue Ridge structural province. Along nearly all of its trace, the Buffalo Mountain thrust places Chilhowee Group clastics over Knox Group carbonates.

The Buffalo Mountain thrust sheet is folded along with the underlying Shady Valley thrust sheet into the broad Stony Creek syncline (Bearce 1966, 1969), (see Figure 10, page 32). This synclinal geometry is most evident in the northeastern end of the Buffalo Mountain sheet (Buffalo Mountain area) where the Buffalo Mountain thrust fault bounds a tongue-shaped body of rocks (Ordway, 1949, 1959).

The northeastern end of the sheet (Buffalo Mountain area) is composed of four interleaved thrust slices separated by three imbricate faults (see Figure 11). The lowest imbricate sheet is the Cherokee sheet (Ordway, 1949,

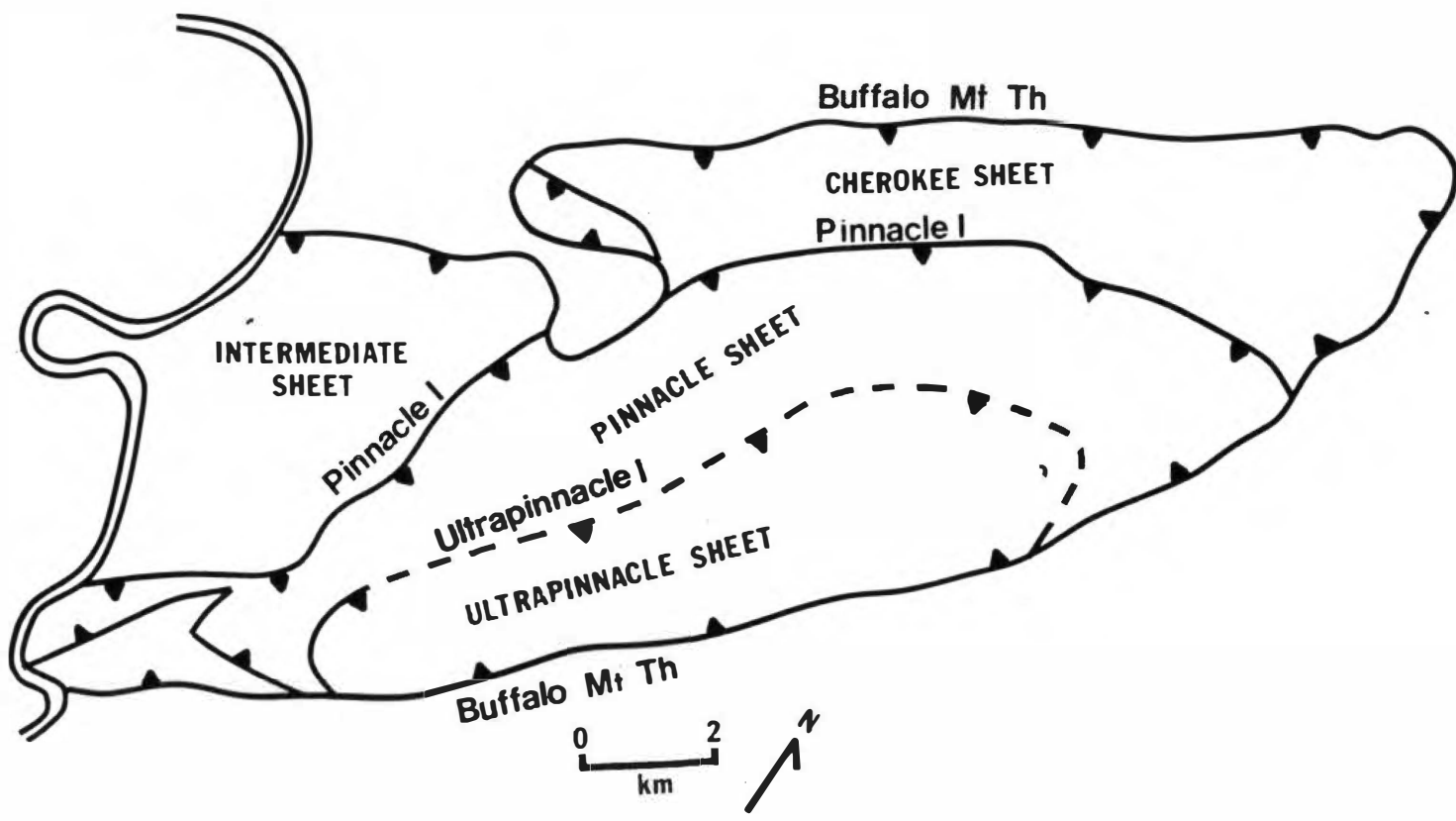

Figure 11. General structure map of the Buffalo Mountain area showing the position of imbricate thrusts and sheets. (modified from Ordway, 1949, 1959; Diegel, in press a and b).



1959). The Cherokee sheet forms the extreme northwestern section of the Buffalo Mountain area. The Cherokee sheet is overlain to the southwest by the Intermediate sheet (Ordway, 1949, 1959), and to the southeast by the Pinnacle sheet (Ordway, 1949, 1959). The southwestern end of the Pinnacle sheet overlies the Intermediate sheet. The highest imbricate sheet in the Buffalo Mountain area is the Ultrapinnacle sheet (this thesis), which overlies the Pinnacle sheet. A branch line map of the Buffalo Mountain area (see Figure 12) also shows the interleaved or interlapping nature of the imbricate sheets.

#### Map Relations and Larger Scale Features

##### Cherokee Sheet

The Cherokee imbricate thrust sheet extends from Warm Cove and Cherokee Knob northeast to Round Knob, and is the lowest imbricate sheet in the Buffalo Mountain thrust pile (see Plate 1). The Cherokee sheet is composed of a sequence of Chilhowee clastics that are gently folded into a southeast-dipping, northeast-striking homocline. The northeast end of the sheet is folded into a southwest plunging syncline. The border of the Cherokee sheet is outlined to the northwest and northeast by the Buffalo

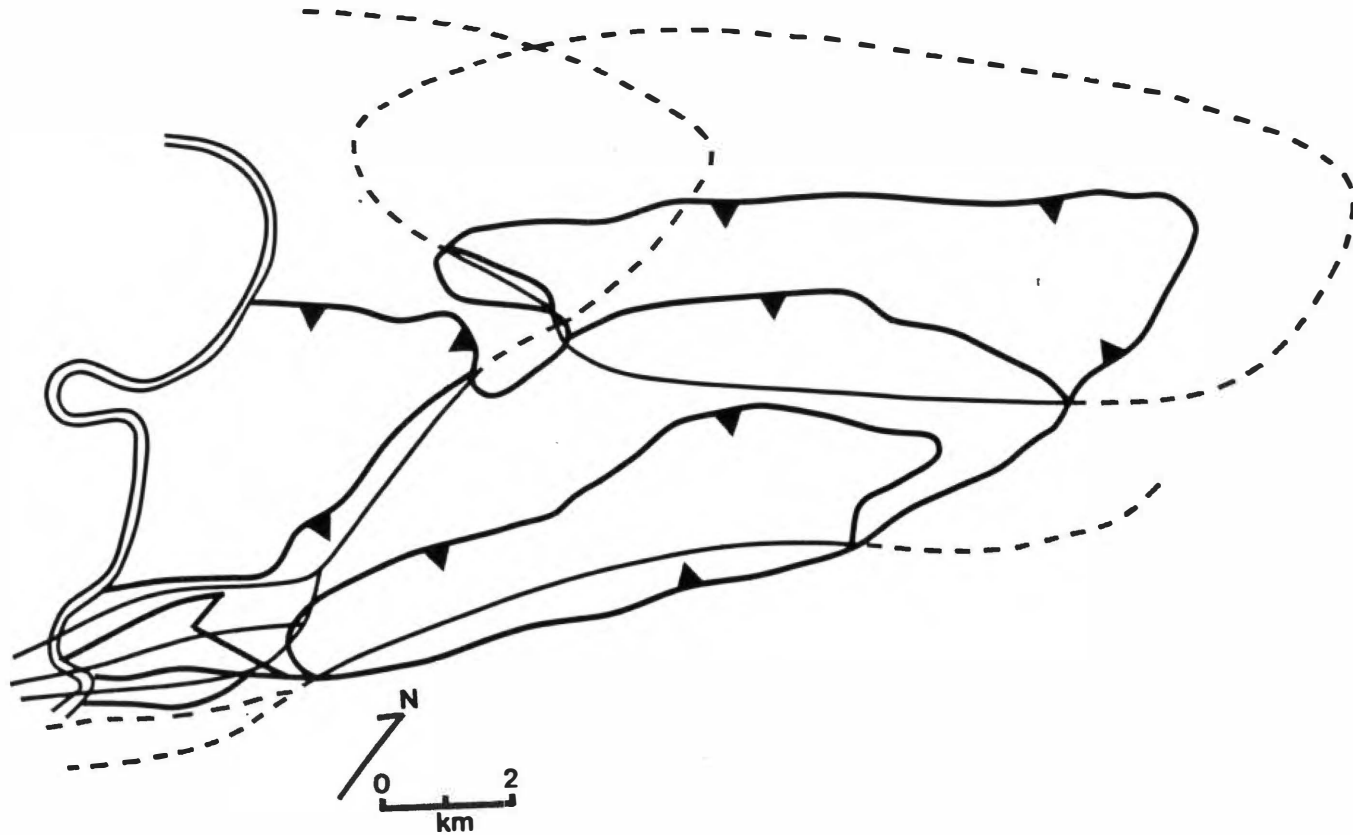

Figure 12. Branch-line map of the Buffalo Mountain area. Dashed lines indicate leading branch-lines that have been removed by erosion. Solid lines are unexposed trailing branch-lines. Note the overlapping nature of the imbricate sheets. (modified from Diegel, in press a and b).

Mountain thrust and to the southeast by the overriding Pinnacle imbricate.

The orientation of the Buffalo Mountain thrust and related imbricates is shown in Figure 13. Around the Cherokee sheet, the Buffalo Mountain thrust consistently dips inward  $45^{\circ}$  to  $50^{\circ}$  and generally strikes to the northeast. Along the border of the Cherokee sheet Hampton and upper Unicoi clastics act as hanging wall rocks with Knox Group carbonates of the Holston Mountain sheet in the foot wall.

#### Intermediate Sheet

The Intermediate sheet extends from near Warm Cove southwest along the Buffalo Mountain thrust to the Nolichucky River and into the Bumpass Cove area (see Plate 1). Outcrops are best along the Nolichucky River, Deacon Creek, Tellico Branch and Millstone Creek. The Intermediate sheet is composed of a conformable sequence of upper Unicoi, Hampton and Erwin formations that are folded into a broad northeast striking, southeast dipping homocline. Dip within the homocline decreases to the southeast. The northern corner of the sheet, near Warm Cove, is folded into a south plunging syncline. The Intermediate sheet is wedged between the underlying Cherokee and overlying Pinnacle imbricate sheets.

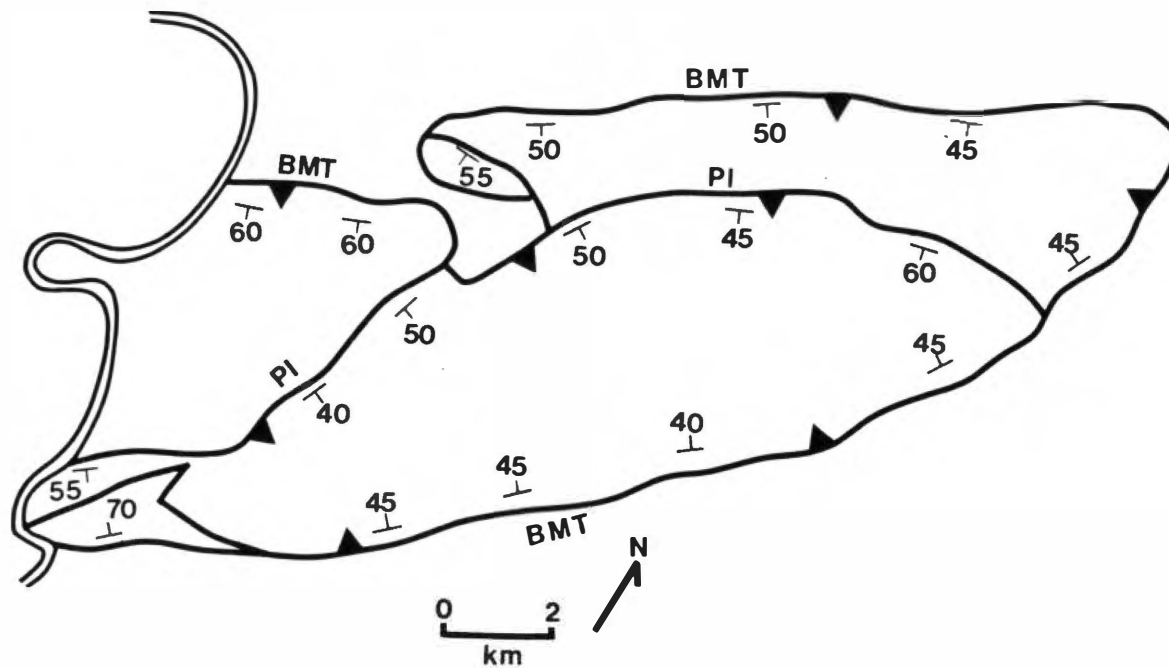

Figure 13. Structure map of the Buffalo Mountain area showing the orientation of the Buffalo Mountain thrust and related imbricates. Orientation data was determined by near surface structure contouring of fault traces. (modified from Ordway, 1949, 1959).

The northwestern edge of the Intermediate sheet beyond the Cherokee sheet is formed by the Buffalo Mountain thrust fault (see Figure 11). The thrust plane strikes north  $50^{\circ}$  east and dips to the southeast  $60^{\circ}$  (see Figure 13). In this area the Buffalo Mountain thrust places upper Unicoi clastics over Knox Group carbonates (see Plate 1).

Directly in front of the Intermediate sheet and beneath the Buffalo Mountain thrust, the Knox carbonates are warped into an anticline-syncline fold pair (see page 48). This fold pair is well exposed just north of Millstone Creek and can be easily viewed from the west bank of the Nolichucky River, along TN Rt 81, 9.6 kilometers (6 miles) north of Erwin, Tennessee. At this locality the anticline is a broad, open, asymmetrical fold, northwest of the syncline. The syncline, located directly beneath the thrust fault, is a tight, similar fold, overturned to the northwest. The overturned upper limb is parallel or nearly parallel to the Buffalo Mountain thrust. Overturned and vertical Knox beds can be traced northeast beneath the fault to near Dry Creek. Apparently this structure formed when the Buffalo Mountain thrust sheet rode over foot wall Knox. As the sheet moved, a section of the Knox strata was peeled of the foot wall and overturned.

The structure of the hanging wall of the Buffalo Mountain thrust is much simpler. Immediately above the thrust, strata of the upper Unicoi strike north  $50^{\circ}$  east

and dip  $50^{\circ}$  to the southeast. Within the Intermediate sheet a resistant white quartzite to maroon grey coarse-grained sandstone unit spans from northwest of Jump Hill south to Shinbone Rock and southeast along the Nolichucky River to Stony Point (see Plate 1). This unit outlines the homoclinal structure of the sheet. When viewed from the church 500 meters (1,500 feet) northeast of Embreeville, on TN 81 S/107 E, the resistant unit appears to be horizontal. Direct measurement of the unit along TN 106 northeast of Jump Hill, however, indicates it actually strikes north  $30^{\circ}$  east and dips  $30^{\circ}$  to  $35^{\circ}$  southeast (away from the observer at the church). Furthermore, from the church, one can observe a minor antithetic contractional (thrust) fault and its associated hanging wall anticline (see Figures 14 and 15). The fault is located about 1,000 meters (3,000 feet) northeast of Shinbone Rock, strikes north  $70^{\circ}$  east, and dips  $30^{\circ}$  to  $40^{\circ}$  northwest. Displacement along the fault is approximately 10 to 20 meters (30 to 40 feet). The hanging wall anticline is concentric in shape, with a fold axis that trends north  $75^{\circ}$  east and plunges  $5^{\circ}$  northeast.

Exposures of the resistant Hampton unit at Shinbone Rock and just southeast of Shinbone Rock (across the Nolichucky River) display well-developed cross-beds that indicate stratigraphic younging is to the southeast. Strata at these localities strike north  $40^{\circ}$  east and dip

Figure 14. Field photo of the Buffalo Mountain thrust fault and complexly folded Knox carbonates. Directly beneath the thrust, the Knox is folded into a tight overturned syncline. Beds in the overturned limb are nearly parallel to the thrust. North of the syncline the Knox is folded into an asymmetrical anticline and minor syncline.

Figure 15. Field photo of minor antithetic contractional (thrust) fault and associated hanging wall anticline. The fault plane strikes north 70° east, and dips 30° to 40° northwest. The fold axis of the anticline trends north 75° east and plunges 5° northeast.

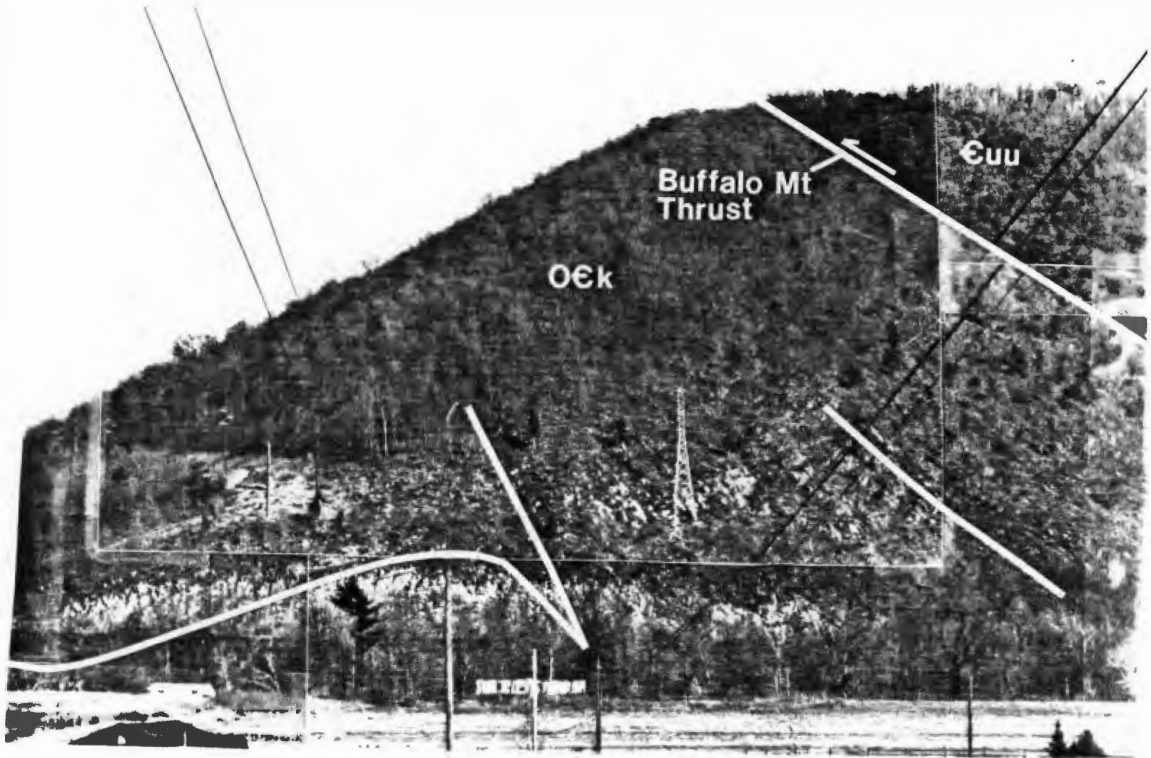

Figure 14.

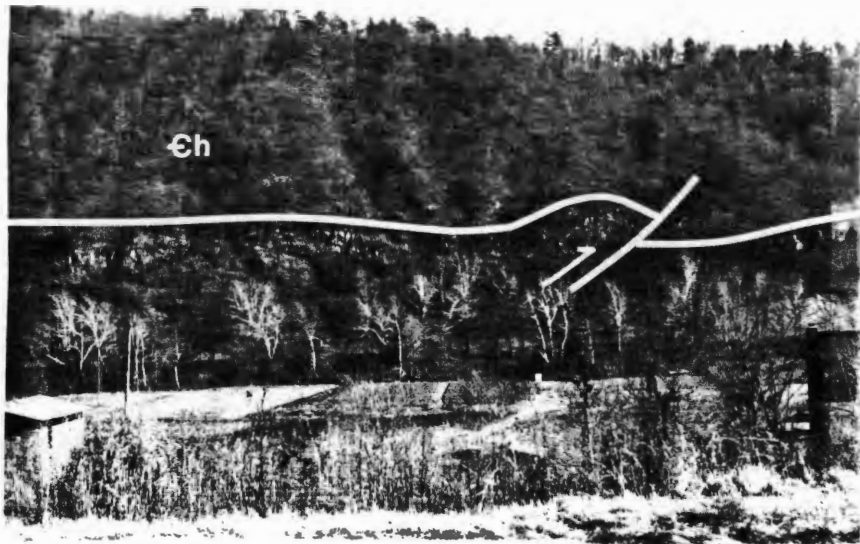

Figure 15.



southeast  $20^{\circ}$  to  $30^{\circ}$ . Southeast of Shinbone Rock, along the Nolichucky River, the resistant unit of Hampton becomes nearly horizontal with dips averaging between  $10^{\circ}$  and  $20^{\circ}$  southeast. Near Stony Point, however, the dip of the unit increases to  $30^{\circ}$  southeast with strike oriented at north  $30^{\circ}$  east.

East of the Nolichucky River, well-bedded shales and sandy shales exposed along Deacon Creek and Tellico Branch (see Plate 1) reflect the homoclinal structure of the interior of the Intermediate sheet. Along Deacon Creek, beds generally strike north  $30^{\circ}$  east and dip between  $15^{\circ}$  and  $35^{\circ}$  southeast. The strata within Tellico Branch strike north  $35^{\circ}$  east and can dip up to  $50^{\circ}$  southeast.

The northeastern corner of the Intermediate sheet is folded into a south plunging syncline (see Plate 1). The limbs of the syncline dip inward from  $15^{\circ}$  to  $50^{\circ}$ . Southward from the syncline, bedding first becomes horizontal and then dips to the southeast. Farther south, near Deacon Creek, no evidence of the northeastern syncline is present.

The Erwin Formation forms the southeastern border of the Intermediate sheet. Two prominent quartzite units within the Erwin define the gross structure of this part of the sheet. The quartzite units strike north  $40^{\circ}$  to  $50^{\circ}$  east and dip from  $45^{\circ}$  to  $55^{\circ}$  southeast. Shales and siltstones interlayered with the quartzites, however, are

crumpled into east-west trending folds. Northeast of Tellico Branch the quartzite units disappear making mapping in this area difficult.

The Intermediate sheet is disturbed in two places by minor tear faulting. The first fault, located at Millstone Creek, trends north 25° east and offsets the ridge forming quartzite at the base of the Unicoi. The fault is a right lateral tear fault with about 50 meters (80 feet) of displacement. The second fault, located northwest of Canah Hollow, trends almost due north and offsets two quartzite units within the Erwin. Drag folding of the quartzite units suggests that the fault is a left lateral tear fault. About 250 meters (750 feet) of displacement is associated with the fault. Other minor faults probably occur in the Intermediate sheet and throughout the Buffalo Mountain area, but because of the lack of outcrop they are undetected.

### Pinnacle Sheet

The Pinnacle sheet is a doubly plunging, synclinally folded mass of Unicoi and Hampton strata that is outlined by the northwest dipping Buffalo Mountain thrust and the southeast dipping Pinnacle imbricate thrust (see Figure 11, page 40). The Buffalo Mountain thrust generally strikes north 30° east and dips 45° northwest (see Figure 13, page

44). The Pinnacle imbricate strikes from north  $10^{\circ}$  west to north  $70^{\circ}$  east and dips to the south or southeast  $40^{\circ}$  to  $60^{\circ}$  (see Figure 13, page 44).

Within the field area outcrop of the Pinnacle sheet is scarce. The rocks that are present outline the synclinal nature of the sheet (see Plate 1). South of Stony Point, lower Unicoi shales and sandstones strike north to northeast and dip  $30^{\circ}$  southeast. Southeast of Stony Point near Canah Hollow, the rocks strike northeast and dip  $35^{\circ}$  to  $45^{\circ}$  northwest.

#### Ultrapinnacle Sheet

The Ultrapinnacle sheet, named in this thesis, is the highest imbricate sheet within the Buffalo Mountain thrust pile. It overlies the Ultrapinnacle imbricate fault and extends to the southeast to the Buffalo Mountain thrust (see Figure 11, page 40). Ordway (1949, 1959) recognized the southwestern nose of the Ultrapinnacle sheet near Ashhopper Hollow because of the occurrence of lower Unicoi rocks within a mass of upper Unicoi (see Figure 16). Diegel (personal communication) has mapped the northeastern nose of the Ultrapinnacle imbricate near Briar Creek and extends it southwest to merge with the fault near Ashhopper Hollow (see Figure 11, page 40). This fault explains the unusual thickening of upper Unicoi strata and the offset

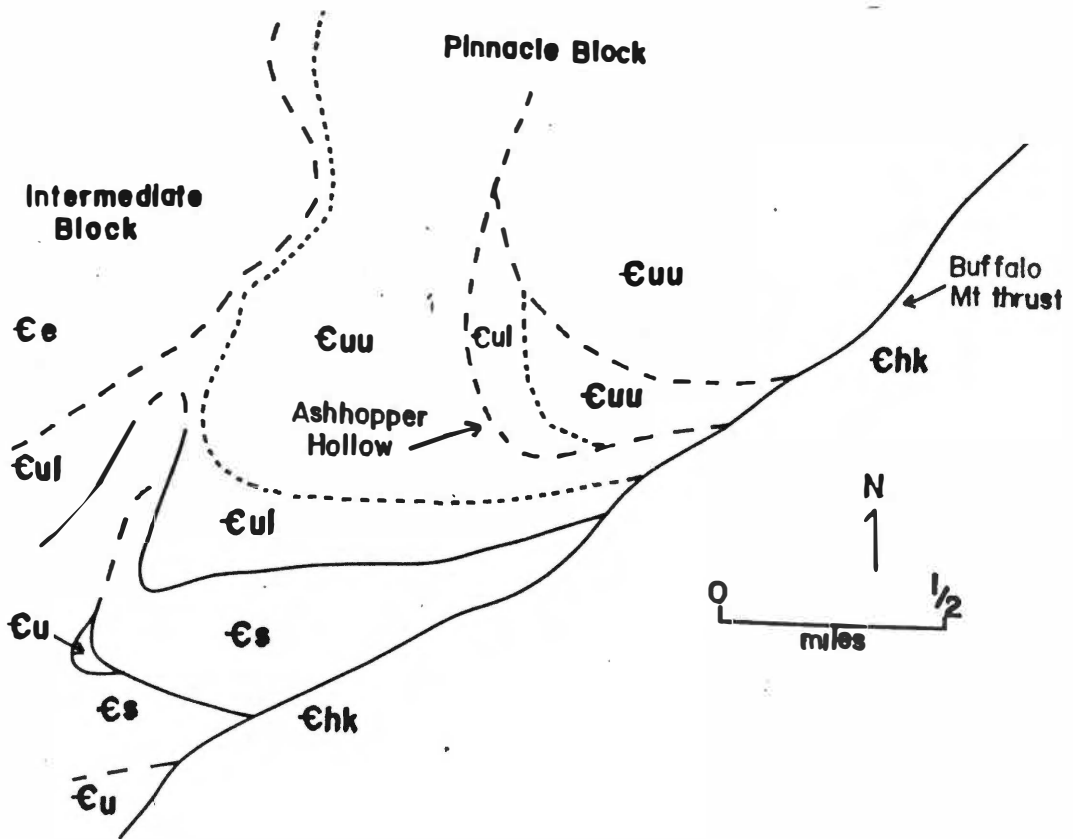

Figure 16. Geologic map of the Ashhopper Hollow area showing the southwestern end of the Ultrapinnacle sheet as mapped by Richard Ordway (1949, 1959).

of Hampton near Briar Creek within the Buffalo Mountain syncline.

Within the field area, the Ultrapinnacle sheet forms a northeast plunging syncline. Outcrop is best on the southeastern limb of the syncline especially in Ashhopper and Harris Hollow and in the small gorge of Indian Creek. At these localities rocks of the lower and upper Unicoi consistently strike north  $40^{\circ}$  east and dip  $30^{\circ}$  to  $50^{\circ}$  northwest (see Plate 1). Within Whaley Brook (Pippen Hollow), lower and upper Unicoi rocks form the southeastern limb of the syncline but are locally warped into northeast-southwest trending folds. The Buffalo Mountain thrust plane strikes north  $40^{\circ}$  east and dips  $40^{\circ}$  northwest (see Figure 13, page 44).

#### Canah Hollow

Canah Hollow is located about 1 kilometer (0.6 miles) north of Erwin, Tennessee. Structurally the area is composed of five complexly arranged units of rock (see Figure 17). The five units are: the southeastern edge of the Intermediate sheet; the southwestern end of the Pinnacle sheet; a unit of Shady located southeast and southwest of the Pinnacle sheet; a large mass of Unicoi positioned just southeast of the unit of Shady; and southeast of the mass of Unicoi, a section of the Holston

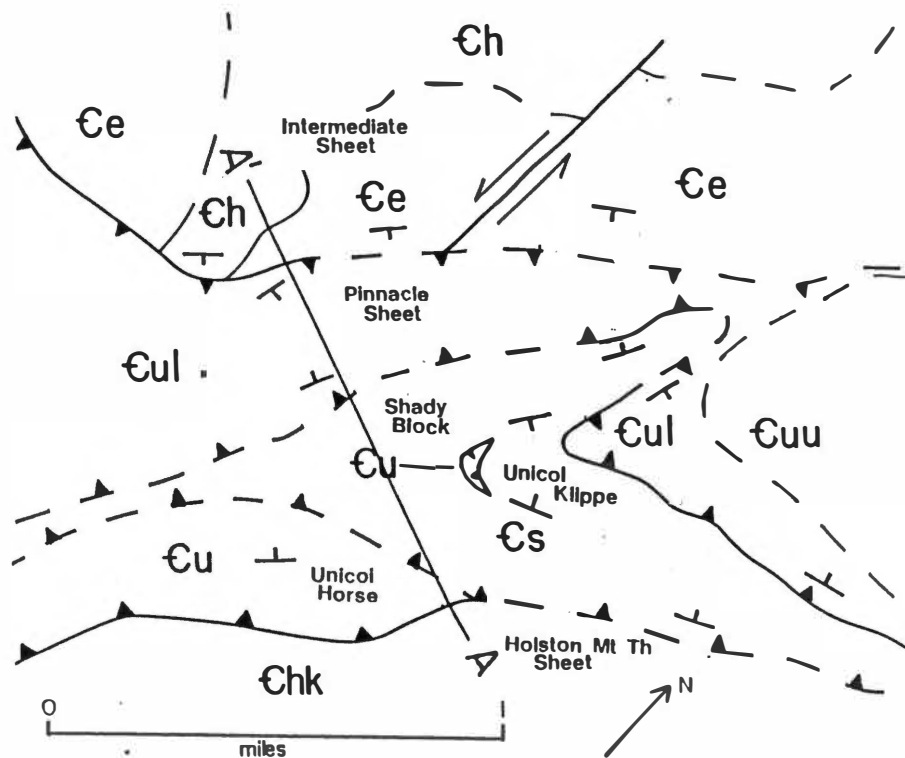

Figure 17. Geologic map of the Canah Hollow area showing the structural components of the area. The components are: the southeastern edge of the Intermediate sheet; the southwestern end of the Pinnacle sheet; a unit of Shady located southeast and southwest of the Pinnacle sheet; a large mass of Unicoi positioned just southeast of the unit of Shady; a small klippe of Unicoi overlying the Shady; and the Holston Mountain thrust sheet (foot wall of the Buffalo Mountain thrust) located southeast of the mass of Unicoi.

Mountain thrust sheet (footwall of the Buffalo Mountain thrust).

The southwestern end of the Pinnacle sheet is in thrust contact with both the southeastern edge of the Intermediate sheet and the large unit of Shady. Both the Pinnacle sheet and the unit of Shady are folded into a northeast plunging anticline-syncline pair. Beds within the southeastern mass of Unicoi are not folded, but strike north  $30^{\circ}$  west and dip  $70^{\circ}$  northwest (see Plate 1). The mass of Unicoi dips northwest beneath the Shady and is underlain by the northwest dipping Holston Mountain thrust sheet. In addition, the mass of Unicoi is completely enveloped by thrust faults, and graded beds indicate that stratigraphic younging is to the northwest. A sixth unit of rock (see Figure 17), a minor slice of Unicoi, located on the ridge east of Canah Hollow, overlies and is folded along with the Shady.

### Three-dimensional Summary View

A three-dimensional view of fault surfaces in the Buffalo Mountain area can be constructed by using the data from several graphical techniques. Initially, the trend and plunge of the fault surfaces are obtained from their near surface orientations (on a stereo net). A projection

of the trend and plunge of the fault surfaces in the Buffalo Mountain area is shown in Figure 18. An along-strike cross-section of the Pinnacle sheet, using the trend and plunge data, reveals that the Pinnacle sheet is a broad, flat-bottomed, U-shaped doubly plunging synform with the northeast end plunging more steeply than the southwest end (see Figure 19). The plunge flattens out at about 400 to 430 meters (1,200 to 1,400 feet) below sea level. The maximum depth of the structure is 530 meters (1,600 feet) below sea level.

A serial down-plunge projection (Badgley, 1959) of the Buffalo Mountain area (see Figure 20) shows that the imbricate sheets have relatively narrow, concentric cross-sectional shapes. The down-plunge projection illustrates the complex stacked arrangement of the thrust pile. These techniques provide the constraints for the structure contour diagram shown in Figure 21. The deep structure contour map highlights the contrasting shape of the imbricate sheets along strike and across strike. Along strike, the sheets are generally broad and flat-bottomed. Across strike, however, the sheets are relatively narrow and concentric in shape.





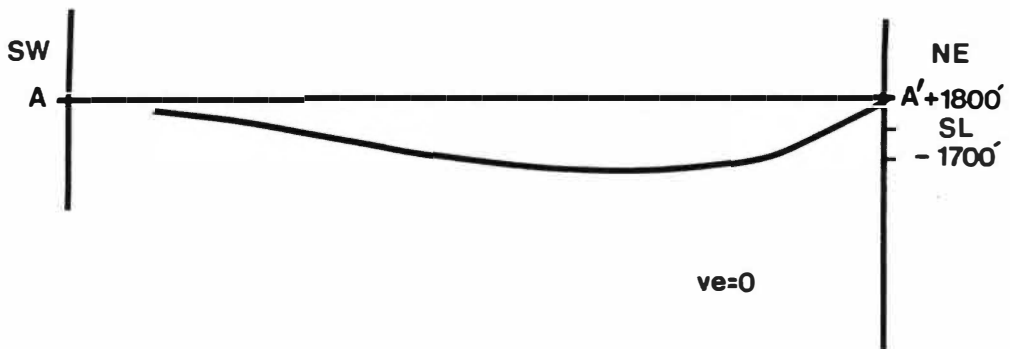

Figure 19. Along strike cross-section of the Pinnacle imbricate sheet based on the trend and plunge data in Figure 18. The cross-section shows that the Pinnacle sheet is a broad flat-bottomed U-shaped doubly plunging synform. The northeast end plunges more steeply to the southwest than the southwest end plunges to the northeast.

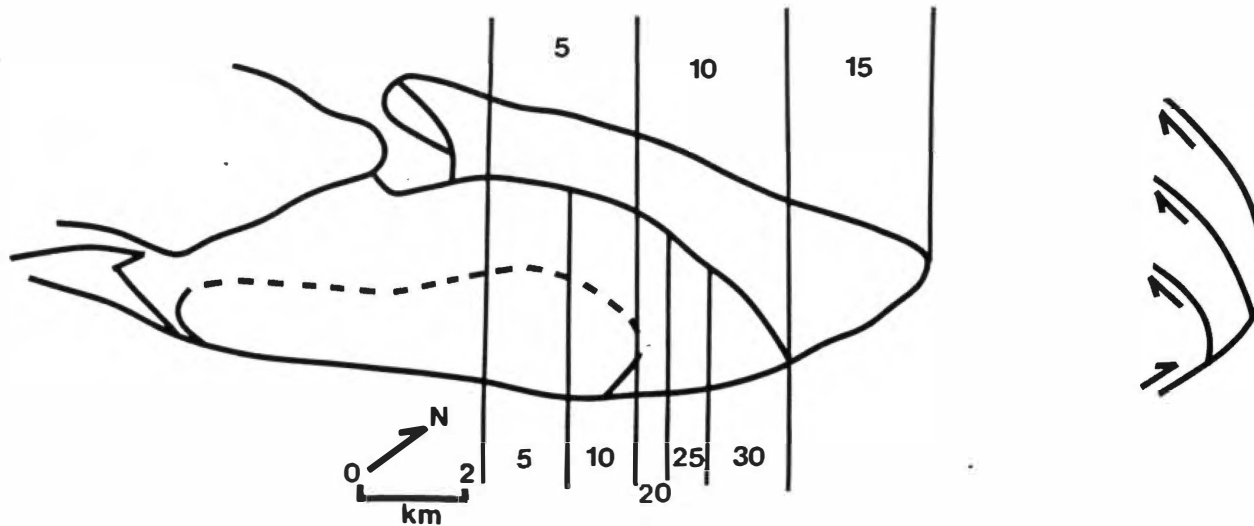

Figure 20. Serial down structural plunge projection of the Buffalo Mountain area. The projection illustrates the complex stacked arrangement of the thrust pile; and that the individual imbricate sheets are relatively narrow and concentric in shape.

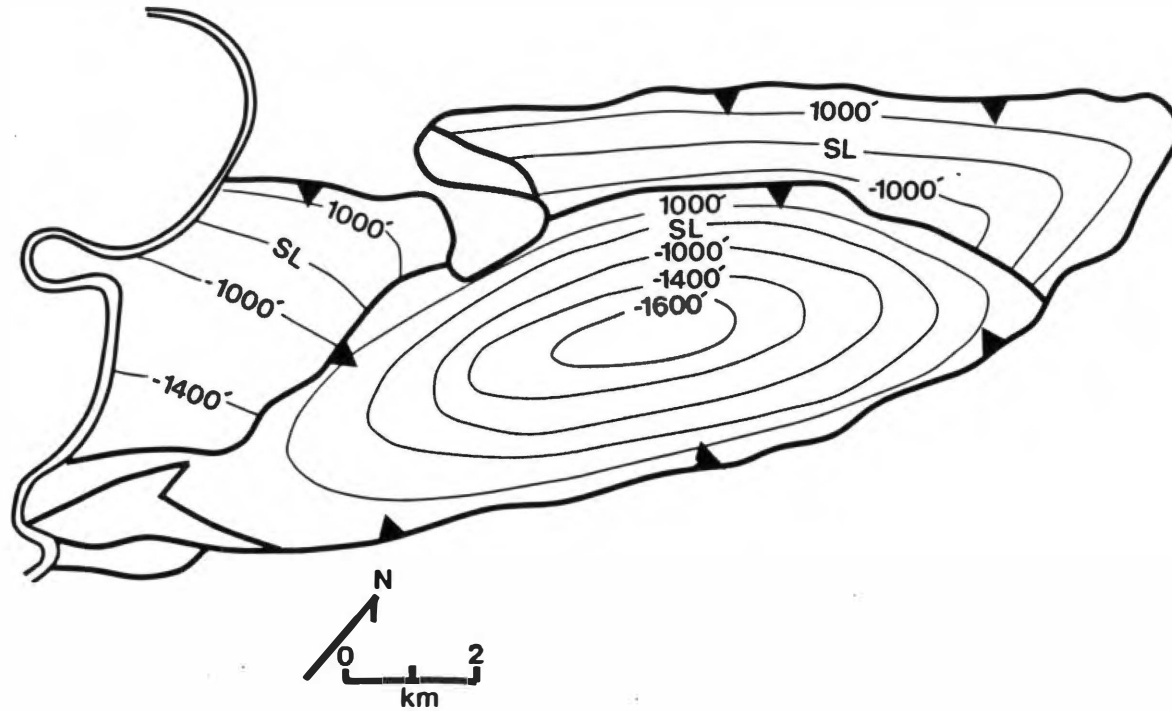

Figure 21. Deep structure contour map of the Buffalo Mountain area. The map highlights the contrasting shapes of the imbricate sheets along strike and across strike. Along strike, the sheets are generally broad and flat-bottomed; across strike, the sheets are relatively narrow and concentric in shape.

## CHAPTER VI

### MESOFABRIC AND MICROFABRIC FEATURES

#### Introduction

Several types of mesofabric and microfabric features are present in the Buffalo Mountain area. The carbonate rocks (Knox and Shady) located near the Buffalo Mountain thrust and the Pinnacle imbricate thrust display a cataclastic fabric. The cataclastic fabric is composed of crushed, cracked, and fractured grains that lack an internal foliation. Stylolitic pressure solution traces, and mineral-filled conjugate en echelon fractures are also present. Folds within the carbonates are tight and similar. Deformation within the hanging wall clastic rocks (Chilhowee) is characterized by quartz-filled fractures, fractured grains, pressure solution traces, undulatory extinction, and slickensided bedding surfaces. Along the base of the Buffalo Mountain thrust sheet detrital quartz grains have been stretched into a mylonitic fabric defined by quartz ribbons. Folds within the clastics are open and concentric.

## Intermediate Sheet

Complexly folded Knox carbonates are well exposed 2 kilometers (1.2 miles) north of TN 81 S/107 E along TN 106 (see Figure 14, page 47). The outcrop spans about 400 meters (1200 feet) with little vegetation cover. At the extreme northern end of the outcrop the Knox is folded into a small open syncline. The northwestern limb of the syncline strikes north  $70^{\circ}$  east and dips  $15^{\circ}$  south. The southeastern limb strikes north  $75^{\circ}$  east and dips  $20^{\circ}$  north. The hinge line of the syncline trends north  $75^{\circ}$  east and plunges  $0^{\circ}$ ; the axial plane strikes north  $75^{\circ}$  east and dips  $80^{\circ}$  south (see Figure 22). 60 meters south of the syncline the Knox arches over forming a broad, concentric anticline that is slightly overturned to the southeast. The northwestern limb of the anticline strikes north  $75^{\circ}$  east and dips  $20^{\circ}$  north. The southeastern limb strikes north  $75^{\circ}$  east and dips  $20^{\circ}$  south. The hinge line of the anticline trends north  $75^{\circ}$  east and plunges  $0^{\circ}$ ; the axial plane strikes north  $75^{\circ}$  east and dips  $75^{\circ}$  northwest (see Figure 22). Immediately south of this anticline, the Knox is sharply folded back into a tight similar syncline that is overturned to the northwest. The northwestern limb of the syncline strikes north  $70^{\circ}$  east and dips  $45^{\circ}$  south. The southeastern limb is overturned (stratigraphic up is to the north) and strikes north  $80^{\circ}$  east and dips  $75^{\circ}$  south.

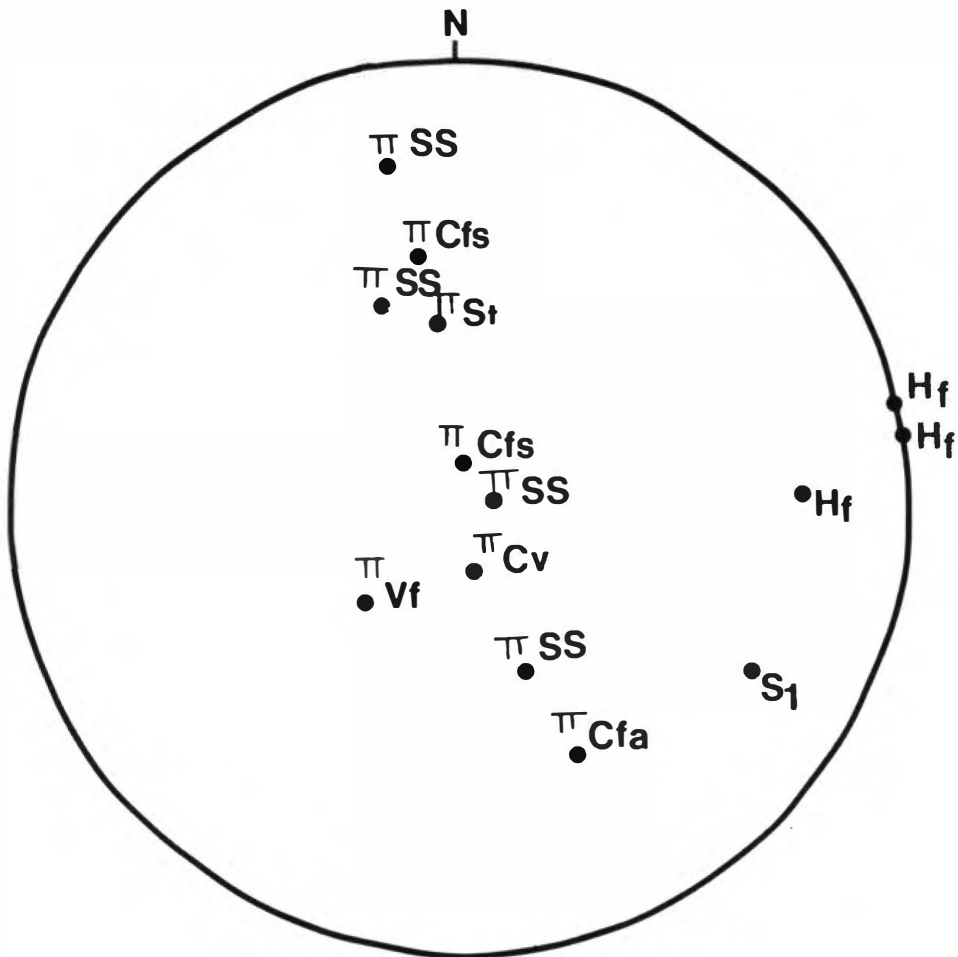

Figure 22. Stereogram summary of the mesofabric elements associated with the complexly folded Knox.  $\pi$ SS = pole to bedding; Ap = axial plane;  $\pi$ Cv = pole to conjugate fracture;  $\pi$ Cfs = pole to synthetic contractional fault;  $\pi$ Cfa = pole to antithetic contractional fault;  $\pi$ St = pole to stylolitic cleavage; Hf = fold hinge;  $\pi$ Vf = pole to mineral-filled fracture; S<sub>1</sub> = slickenside.

The hinge line of the fold trends north 85° east and plunges 15° south; the axial plane strikes north 85° east and dips 40° southeast (see Figure 22). The southeastern limb of the syncline remains overturned for a distance of 200 meters (600 feet) until it meets the upper Unicoi rocks of the Buffalo Mountain thrust sheet. Dip gradually decreases from 75° south near the syncline to 45° south just beneath the Buffalo Mountain thrust.

Around the northwestern limb of the small syncline at the north end of the exposure, parallel fibrous growths of calcite or slickensides trend south 20° east on the tops of bedding surfaces (see Figure 22). On the southeast limb of the syncline several minor contractional faults with less than .5 meters (18 inches) displacement cut through the Knox. The faults strike north 70° east and dip either to the north and south approximately 60° (see Figure 22). Several thick spary calcite filled veins are located near the crest of the broad anticline. The veins are tabular in shape, strike north 75° east and dip vertically (see Figure 22).

The overturned syncline at the southern end of the outcrop contains a strong pressure solution cleavage within its core ( $\pi$ St of Figure 22). Hand sample (see Figure 23) study indicates that the cleavage ( $S_1$  in Figure 23a) is spaced (2 to 3 centimeters; 1 inch), peaked to smooth in cross-section with a parallel pattern (Borradaile et al.,



Figure 23. Photographs of Knox from the core and limb of the overturned syncline beneath the Buffalo Mountain thrust.

a. Hand sample photograph of Knox from the core of the overturned syncline beneath the Buffalo Mountain thrust.  $S_1$  is a spaced, stylolitic to smooth, parallel pressure solution cleavage that is nearly axial planar to the fold.  $S_0$  is sedimentary bedding.

b. Hand sample photograph of Knox from the southeastern limb of the overturned syncline beneath the Buffalo Mountain thrust.  $S_1$  is a spaced, nearly axial planar or bedding parallel stylolitic pressure solution cleavage.  $S_2$  is a series of thin calcite veins oriented sub-perpendicular to the axial plane.  $S_0$  is sedimentary bedding.

c. Thin-section photograph of Knox from the southeastern limb of the overturned syncline beneath the Buffalo Mountain thrust. The photograph shows a stylolitic cleavage (St) surrounded by an envelope of calcite (Ca). Bar scale is 1 mm in length.

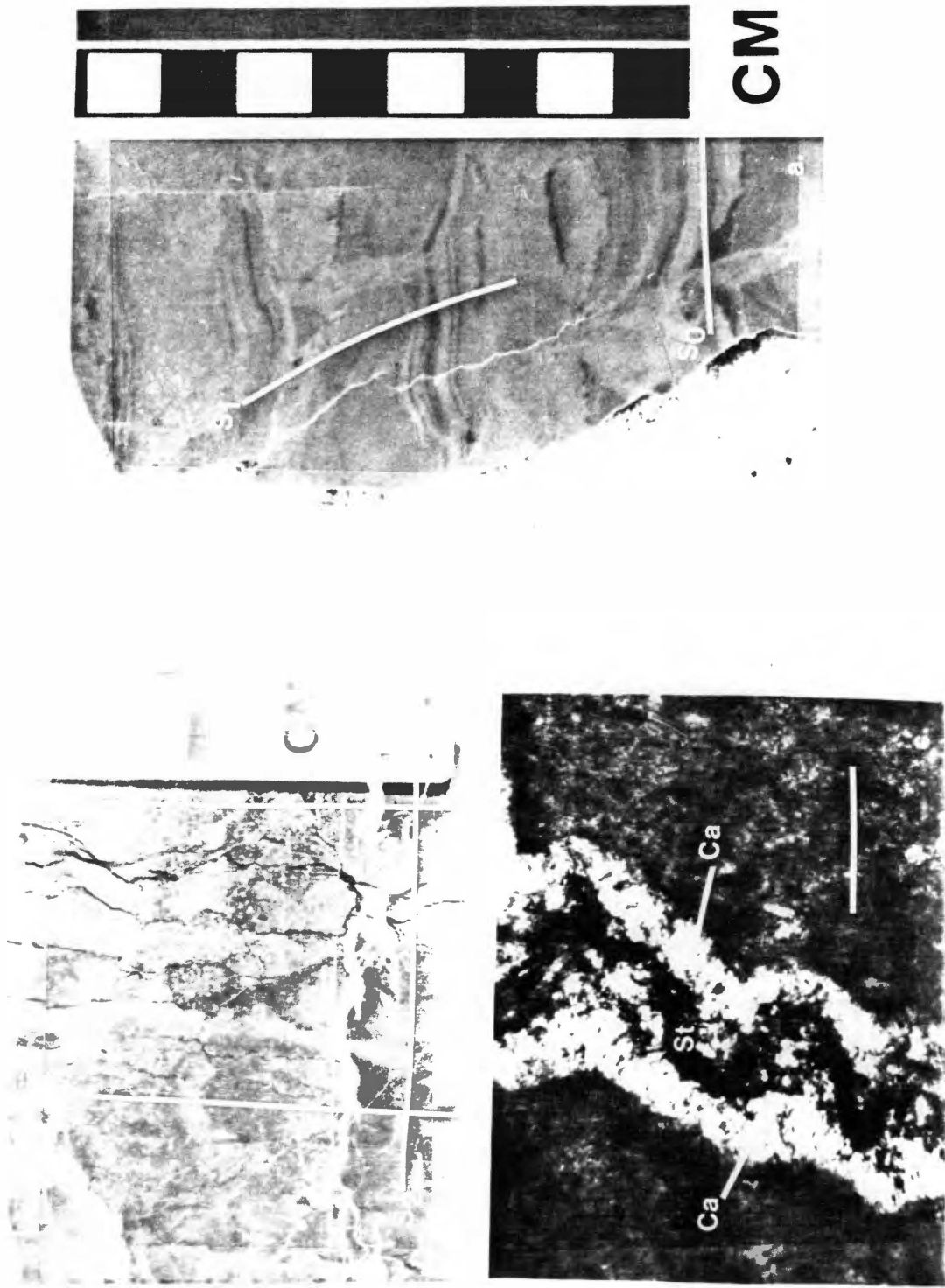

Figure 23.

1982). The cleavage is slightly convergent with respect to the axial fold plane. Also within the syncline core are a series of calcite filled en echelon conjugate fractures. The veins are generally a couple of centimeters long (1 or 2 inches), 1 centimeter thick (0.4 inches), and planar to slightly sigmoidal in shape. The en echelon sets are divergent to the core of the fold. One set of the conjugate fractures strikes north 15° west and dips 60° northwest, the other set is horizontal (see Figure 22).

Along the southeastern limb of the syncline, near the core, several thin calcite veins trend sub-perpendicular to the axial plane (see Figure 23b). The veins ( $S_2$  in Figure 23b) are several meters long, strike north 10° west and dip 25° east (see Figure 22). The calcite within the veins is highly twinned. A stylolitic pressure solution cleavage ( $S_1$  in Figure 23b) is also present. The cleavage is spaced (0.5 to 1.0 centimeters; 1 to 2 inches) and is sub-parallel to the axial plane and to bedding ( $S_0$  in Figure 23b). In thin-section the cleavage both cross-cuts and is cross-cut by the calcite veins. Also, examination of the stylolites reveals that many of the cleavage planes are surrounded by envelopes of calcite veins (see Figure 23c). This feature suggests a complicated history of compression followed by extension for the rock beneath the Buffalo Mountain thrust. Toward the south, away from the syncline, the overturned beds contain many interlayer contractional faults, or

bedding wedges (Cloos, 1961). The faults generally produce several meters of displacement and intersect bedding at about 30° (see Figure 22).

Figure 22, page 63 is a stereogram summary and Figure 24 is a schematic outcrop sketch of the mesoscopic fabric elements associated with the complexly folded Knox. The figure includes bedding, fold orientation, mineral filled and coated fractures, stylolites, faults, and slickensides. Price (1967) discussed mesoscopic fabrics found in the southern Canadian Rocky Mountain foreland belt. Figure 25 is his summary diagram showing the relationship of mesoscopic fabrics to a fold. Comparing the two summaries reveals several similarities. First, in both examples the surfaces of the minor faults are parallel to the hinge line of the fold. Second, both summaries show stylolitic cleavage parallel or nearly parallel to the axial plane. And third, both show slickensides on the bedding surfaces. A difference between the two summaries, however, is that Price's (1967) example did not include en echelon conjugate fractures or veins oriented normal to the axial plane. Both of these features are present in the folds beneath the Buffalo Mountain thrust.

The Buffalo Mountain thrust fault is not exposed in this area. However, it is exposed 1 kilometer south of Cherokee Knob along TN 106 (see Figure 26a). At this location the fault strikes north 75° east, dips 50°

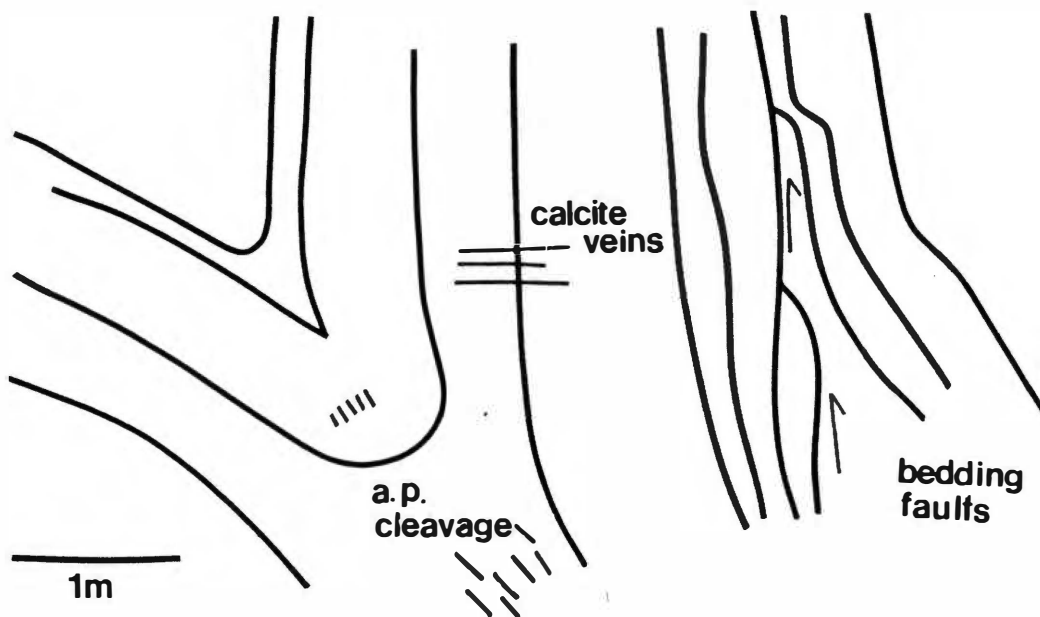

Figure 24. Schematic outcrop sketch of the mesofabric elements associated with the complexly folded Knox.

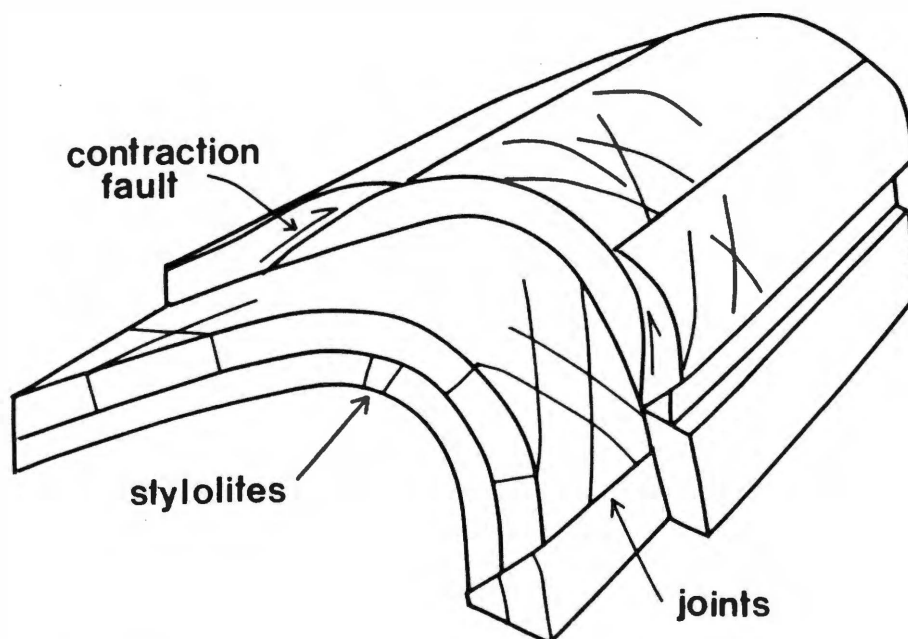

Figure 25. Summary diagram showing the relationship of mesofabrics to folds found in the southern Canadian Rocky Mountain foreland belt (from Price, 1967).

Figure 26. Outcrop and hand sample photographs of the Buffalo Mountain thrust exposed 1 kilometer south of Cherokee Knob along TN 106.

a. Outcrop photograph of the Buffalo Mountain thrust exposed 1 kilometer south of Cherokee Knob along TN 106. The fault strikes north  $75^{\circ}$  east, dips  $50^{\circ}$  southeast and places upper Unicoi clastics over Knox carbonates.

b. Hand sample photograph of upper Unicoi from the hanging wall of the Buffalo Mountain thrust near Cherokee Knob.  $S_1$  is a thin, wispy, dark, planar cleavage oriented sub-parallel to the fault.  $S_2$  is a fracture set oriented perpendicular to the fault plane; the material within the fracture has weathered out.

c. Thin-section photograph of upper Unicoi from the hanging wall of the Buffalo Mountain thrust near Cherokee Knob.  $S_1$  is a smooth to anastomosing incipient pressure solution cleavage. The quartz grains display undulatory extinction and are highly fractured; the fragments of a single grain are optically continuous. Bar scale is 2 mm in length.

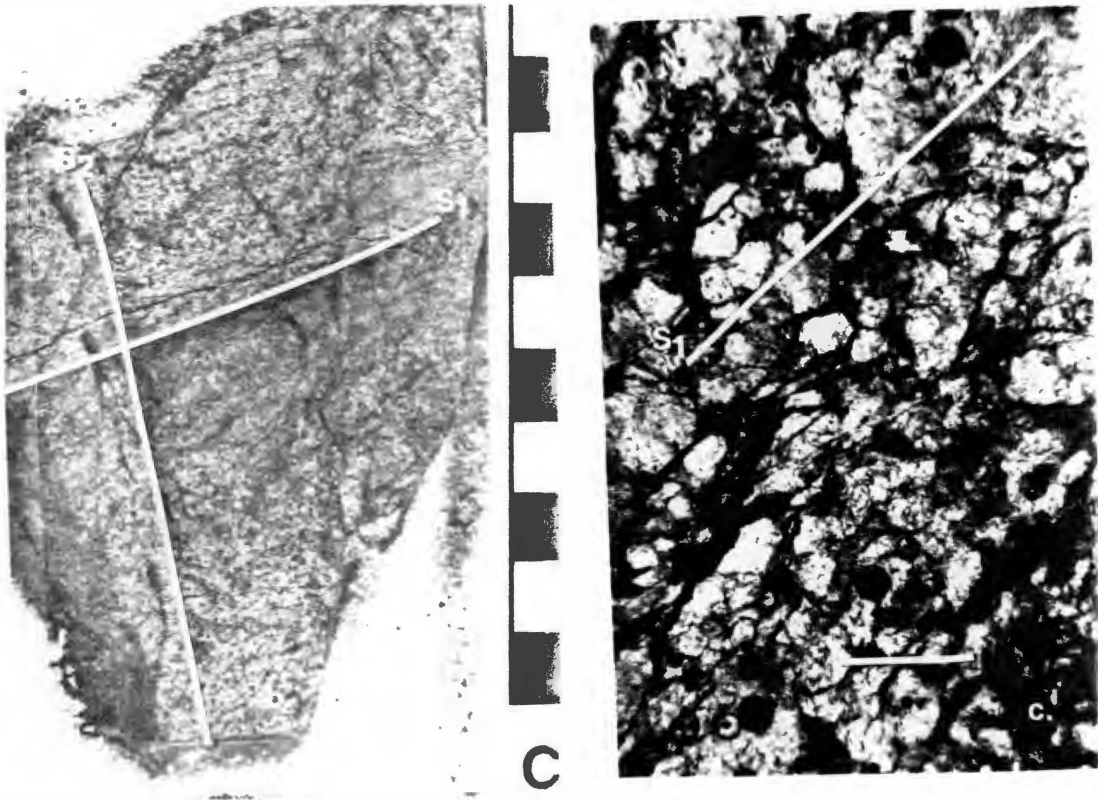
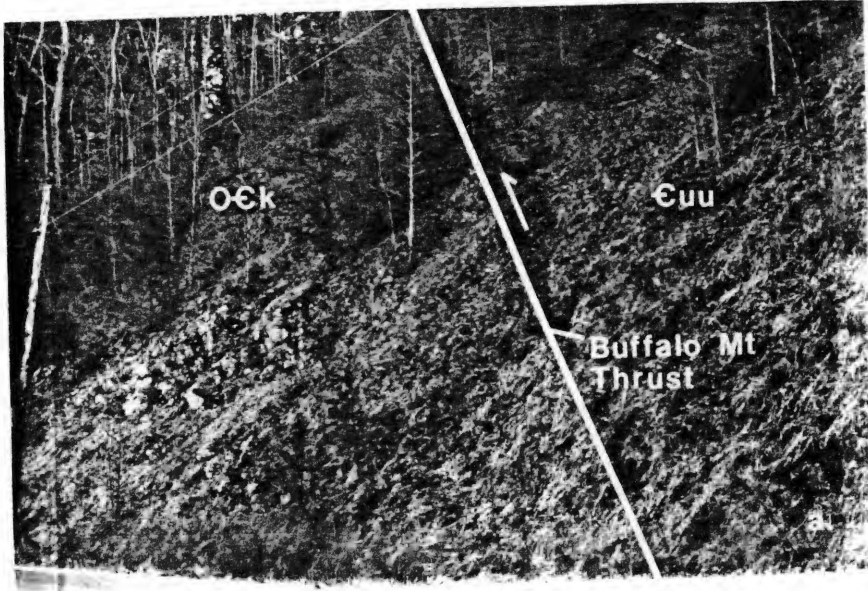

Figure 26.

southeast and places upper Unicoi clastics over Knox carbonates. The Unicoi strikes north 75° east, dips 50° to the south and contains a well developed, closely spaced, planar cleavage. The cleavage is parallel to the thrust plane and dies out a few meters above the fault. Above the cleavage zone the Unicoi is green and shows few deformational features except for bedding perpendicular joints. Handsamples of the Unicoi (Figure 26b) do not display a mylonitic texture and the grains do not appear to possess a preferred orientation. Fractures ( $S_2$  in Figure 26b), spaced about 0.5 centimeters (1 inch) apart, are oriented approximately perpendicular to the fault plane; the material within the fracture has weathered out. A cleavage ( $S_1$  in Figure 26b), visible as thin wispy dark planar traces, is also present. The cleavage is spaced (25 millimeters; 0.1 inches) and is oriented sub-parallel to the fault. In thin-section the cleavage ( $S_1$  in Figure 26c) usually appears as a smooth or straight to anastomosing incipient foliation (Borradaile et al., 1982), (Figure 26c), or as a planar discrete bundle-like foliation. The cleavage planes are marked by an insoluble reddish-brown material. The quartz grains display undulatory extinction and are highly fractured (fractures are easily visible at magnifications of 10x and above). The average size of a quartz fragment is about .01 millimeter in diameter (see



Figure 26c); all of the fragments of a single grain are optically continuous.

The foot wall Knox is overturned, strikes north  $75^{\circ}$  east, dips  $60^{\circ}$  to the south, and contains a well developed cataclastic fabric. Just beneath the fault surface an ultracataclasite is present. The ultracataclasite (Figure 27a) is about 25 millimeters (0.1 inches) thick, buff brown in color with no layering or banding present. In thin-section (Figure 27b), individual grains are difficult to resolve. No internal foliation is present. Stylolitic pressure solution traces parallel the fault plane and form the base of the ultracataclasite zone. In addition, late calcite veins and stylolites cut the ultracataclasite. Beneath the ultracataclasite is a 1 to 2 centimeter (0.5 to 1 inch) thick protocataclasite (see Figure 27a). The protocataclasite is dark grey with no apparent stratification. In thin-section (see Figure 27b) the rock is composed of about 80% matrix and 20% quartz clasts. The matrix is very fine-grained with individual grains difficult to recognize. The clasts are generally 0.05 millimeters in diameter, equant, rhombohedral shaped fragments of quartz that do not exhibit undulatory extinction. The clasts do not possess a preferred orientation. The rock is cut by laterally continuous calcite-filled veins and stylolites (see Figure 27b). The veins form  $30^{\circ}$  to  $60^{\circ}$  angles with the fault plane, and are

Figure 27. Hand sample and thin-section photographs of Knox from the foot wall of the Buffalo Mountain thrust near Cherokee Knob.

a. Hand sample photograph of Knox from the foot wall of the Buffalo Mountain thrust near Cherokee Knob. The ultracataclasite (U) is very fine-grained, with no layering or banding present. The protocataclasite (P) is dark grey with no stratification. The rock is cut by laterally continuous calcite-filled veins and stylolites.

b. Thin-section photograph of Knox from the foot wall of the Buffalo Mountain thrust near Cherokee Knob. The ultracataclasite (U) is fine-grained with no stratification. Stylolites (St) parallel the thrust plane and form the base of the ultracataclasite. The protocataclasite contains equant, fragments of quartz (q) and is cut by calcite-filled veins (Ca). Bar scale is 1 mm in length.

c. Hand sample photograph of Knox from the foot wall of the Buffalo Mountain thrust near Cherokee Knob. The sample is an orthocataclasite that is riddled with thin calcite-filled fractures and late stylolites.

d. Thin-section photograph of Knox from the foot wall of the Buffalo Mountain thrust near Cherokee Knob. The calcite veins of the orthocataclasite form a complex intersecting pattern and divide the rock into subangular aggregates of microcrystalline calcite. Bar scale is 2 mm in length.

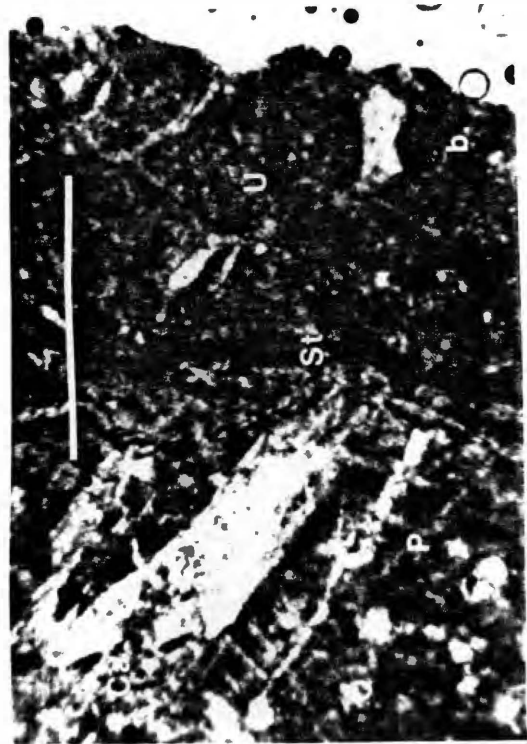
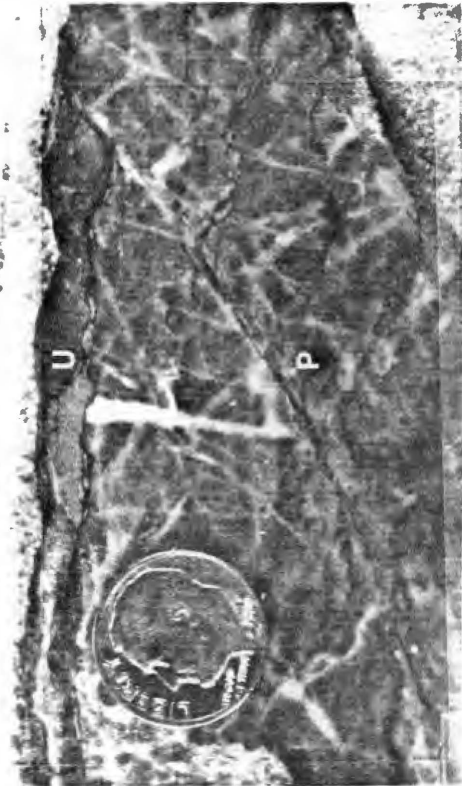
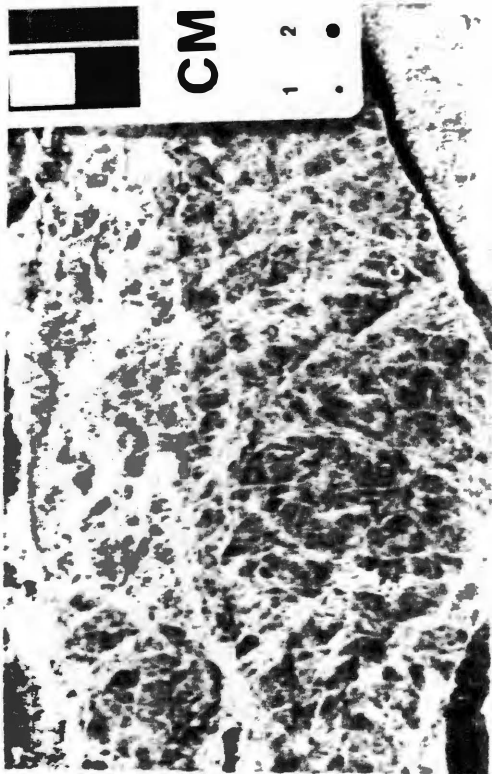

Figure 27.

composed of highly twined calcite (see Figure 27a). Beneath the protocataclasite is an orthocataclasite. Due to the lack of outcrop the thickness of the orthocataclasite is unknown. The rock is riddled with thin calcite-filled fractures and late stylolites (see Figure 27c). In thin-section (see Figure 27d) the orthocataclasite is composed of 85% calcite blocks and 15% vein filling calcite. The calcite veins form a complex intersecting pattern dividing the rock into 75 millimeter (0.3 inch) sized, subangular aggregates of microcrystalline calcite. Furthermore, the blocks possess no preferred orientation.

Within the main body of the Intermediate sheet, 75 meters (200 feet) north of TN 81 S/107 E along TN 106, sandstones of the Hampton are folded into an anticline (see Figure 28a). The folds are concentric and open. The axes of the folds trend north 65° east with no plunge. The Hampton Formation is also folded approximately 50 meters north of the Washington Co.-Unicoi Co. line. Shaly sandstones are warped into a series of open concentric folds with fold axes that trend north 50° east and plunge 5° northeast. Slickensides or fiber growths are common on bedding surfaces and trend north 10° to 30° west.

Bedding-plane exposures of Hampton shales along Deacon Creek and Tellico Branch often reveal slickensides. The slickensides appear as fibrous growths of quartz with small

Figure 28. Photographs of deformational features found in the Hampton and Unicoi.

a. Outcrop photograph of folded Hampton strata near the intersection of TN 81 S/107 E and TN 106. The fold is concentric and open with the fold axis trending north 65° east with no plunge.

b. Hand sample photograph of hanging wall Unicoi from the Pinnacle imbricate exposed along TN 81 S/107 E. Sample shows quartz-filled fractures ( $S_1$ ) oriented sub-perpendicular to the fault plane.

c. Thin-section photograph of hanging wall Unicoi from the Pinnacle imbricate exposed along TN 81 S/107 E. Photo shows the fracture, filled with fine-grained quartz material, cutting through detrital quartz grains. Bar scale is 2 mm in length.

d. Hand sample photograph of hanging wall Unicoi from the Pinnacle imbricate exposed in Canah Hollow. Two sets of conjugate fractures are present.  $S_1$  is parallel to the fault plane.  $S_2$  forms a 30° angle with the fault plane.

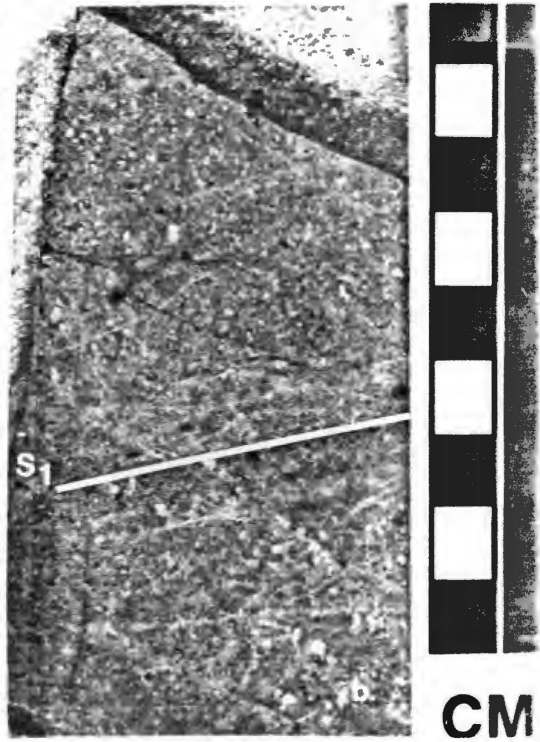

Figure 28.

steps or ledges oriented perpendicular to the quartz fibers. The fibers generally trend north 20° to 40° west. The ledges step upwards to the southeast suggesting that the upper beds moved northwest over the lower beds (Hobbs et al., 1976).

In addition to the slickensides located on the bedding planes of the Hampton along Deacon Creek and Tellico Branch, quartz-filled fractures are also present. The fractures are 1 to 2 centimeters (2 to 5 inches) thick and several meters (feet) in length. The fractures generally strike north 10° to 30° west and dip 60° west to vertical.

#### Pinnacle-Ultrapinnacle Sheets

The Pinnacle imbricate thrust is exposed at only two places in the field area. The first location is 1.2 kilometers (2 miles) north of Erwin, Tennessee along TN 81 S/107 E. At road level lower Unicoi sandy shales are thrust over quartzites of the Hampton, up slope, the lower Unicoi is placed against the Erwin. The thrust strikes north 40° east and dips 50° southeast (see Figure 13, page 44). The hanging wall lower Unicoi strikes north 40° east and dips 25° southeast. Several minor folds within the lower Unicoi contain fold axes that trend north 40° east with zero plunge. The folds are concentric open folds.

The foot wall Hampton strata strikes north 30° west and dips 65° southwest. Concentric open folds within the Hampton contain fold axes that trend north 45° east with zero plunge.

In hand sample neither the Unicoi or Hampton show a mylonitic fabric or a preferred orientation of quartz grains. Quartz-filled fractures within the Unicoi (see Figure 28b) are oriented sub-perpendicular to the fault plane. In thin-section the fractures are composed of fine-grained quartz material (see Figure 28c). The fractures do not seem to follow detrital quartz boundaries, but rather cut through the grains. Figure 28c shows a fracture that has cut through and split a detrital grain into several fragments (note that the fragments of a single detrital quartz grain are optically continuous). Individual detrital quartz grains possess undulatory extinction and are highly fractured or crushed. The fragments are extremely angular and are about 0.01 millimeters (0.004 inches) in diameter; fragments composing a single original grain are optically continuous.

The second outcrop of the Pinnacle imbricate is located 0.8 kilometers (0.5 miles) northeast of TN 81 along the gravel road through Canah Hollow. At this location, upper Unicoi clastics are placed over Shady Dolomite. The outcrop is poorly exposed with only the upper Unicoi beds cropping out in place. The upper Unicoi strata strike



north 55° east and dips 45° southeast. No folds are present, however, the Unicoi does contain 1 to 3 centimeter (2 to 6 inch) spaced joints that are perpendicular to bedding. In hand sample (see Figure 28d), the Unicoi does not have a mylonitic texture or a preferred orientation. Sets of conjugate fractures are present, however. One set ( $S_1$  in Figure 28d) is approximately parallel to the fault plane, the other set ( $S_2$  in Figure 28d) forms about a 30° angle with the fault plane. Several of the larger quartz grains are fractured or smashed. In thin-section, the fractures are composed of fine-grained quartz material similar to the fractures already described in the Unicoi. The fractures in some places follow detrital grain boundaries, and elsewhere cut through detrital grains. Individual detrital quartz grains possess undulatory extinction and are highly fractured. The fragments are subangular in outline and are about 0.2 to 0.4 millimeters (0.03 inches) in diameter; the fragments of most detrital grains are not optically continuous.

The Shady is so poorly exposed that only float fragments are present. Examination of these fragments in hand sample and in thin-section reveals a cataclastic fabric. In hand sample (see Figure 29a), the Shady is composed of subangular blue dolostone fragments set in a fine-grained grey to white matrix; several chalk white fractures cut the rock. No layering or preferred

Figure 29. Photographs of deformational features above the Pinnacle imbricate and the Buffalo Mountain thrust.

a. Hand sample photograph of foot wall Shady from the Pinnacle imbricate exposed in Canah Hollow. Sample shows a cataclastic fabric composed of subangular blue dolostone fragments set in a fine-grained matrix.

b. Thin-section photograph of foot wall Shady from the Pinnacle imbricate exposed in Canah Hollow. The dolostone fragments are composed of highly fractured or twinned dolomite. The matrix is very fine-grained and has no stratification. An anastomosing weak foliation composed of insoluble residue ( $S_1$ ) is present. Bar scale is 2 mm in length.

c. Thin-section photograph of crenulation cleavage at Indian Creek.  $S_1$  is a dark, continuous, closely spaced, smooth to planar cleavage.  $S_1$  is parallel to the Buffalo Mountain thrust.  $S_2$  crenulates  $S_1$  and is oriented upwards facing to bedding. Bar scale is 2 mm in length.

d. Thin-section photograph of crenulation cleavage and quartz ribbons at Indian Creek.  $S_1$  and  $S_2$  are the same as in Fig. 45. Q are quartz ribbons oriented parallel to  $S_1$ . The quartz ribbons have been slightly rotated by  $S_2$ . Bar scale is 1 mm in length.

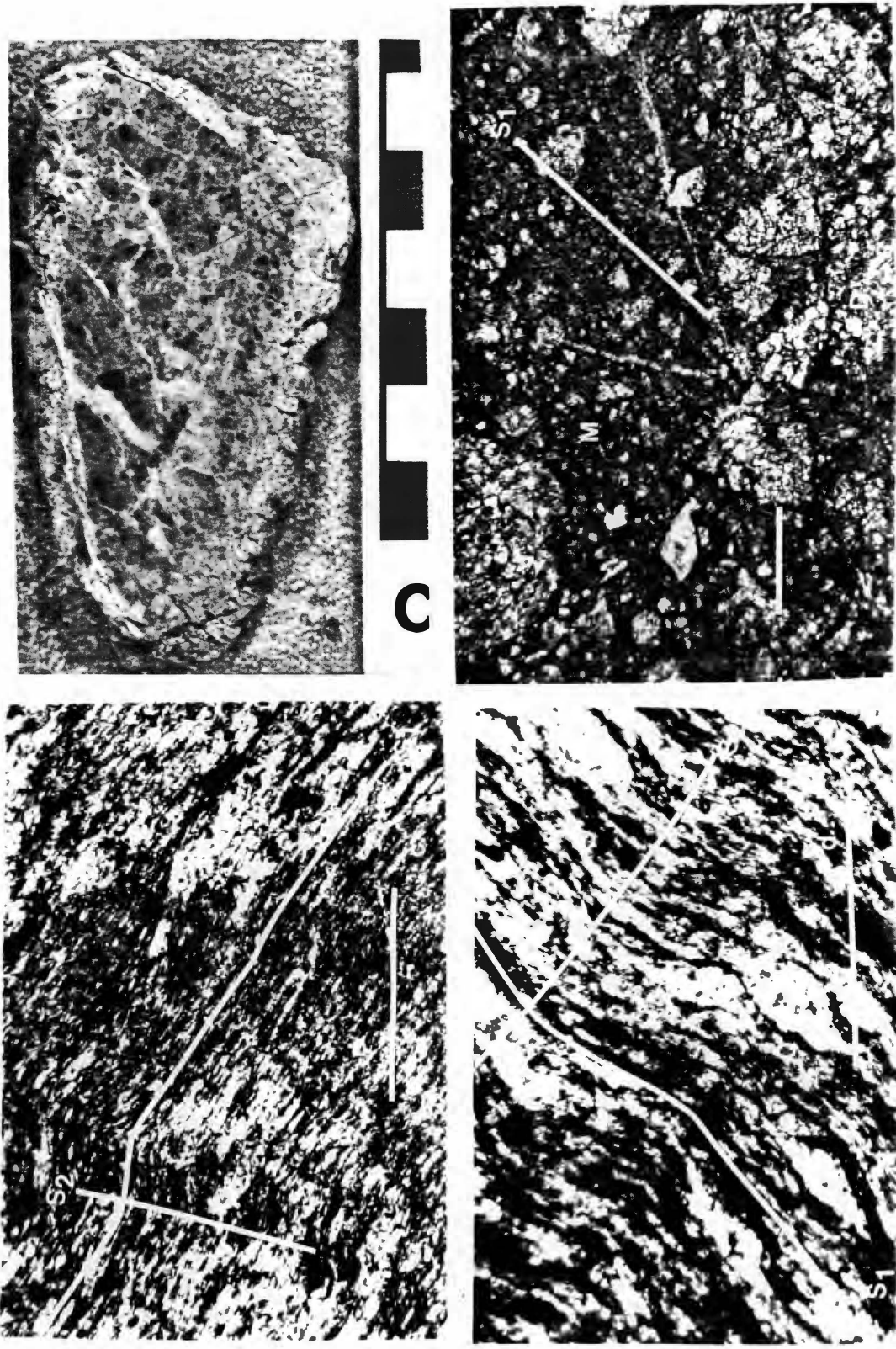

Figure 29.

orientation of the grains is evident. In thin-section (see Figure 29b) the dolostone fragments are 0.4 millimeters (0.04inches) in diameter, subangular to angular and are composed of highly fractured or twinned material. The matrix is very fine-grained and contains occasional rhombs of dolomite. The rock is composed of about 60% matrix and 40% fragments. Fractures filled with twinned calcite cut through both the matrix and the dolostone fragments, and a weak foliation is present. The foliation is anastomosing to planar in shape (Borradaile et al., 1982) and is composed of insoluble residue. The foliation is subparallel to many of the calcite fractures.

On the southeast side of the Ultrapinnacle sheet, along Indian Creek, Ashhopper Hollow, Harris Hollow, and Whaley Brook (Pippen Hollow), two cleavages are present. The first cleavage is found within the gorge of the Indian Creek near Ashhopper Hollow. This cleavage is continuous, tightly spaced and parallel or planar in form. The cleavage strikes north 45° east and dips 40° northwest which is parallel to bedding and the underlying Buffalo Mountain thrust. In thin-section (see Figures 29c, 29d), this cleavage ( $S_1$  in Figures 29c, 29d) appears as a dark, continuous closely spaced feature. The cleavage is smooth and planar in shape. Paralleling this cleavage are thin quartz ribbons (see Figure 29d). The quartz ribbons define a mylonitic foliation (Wilson, 1982). The ribbons are 0.4

millimeters (0.04 inches) in cross-sectional length. The second cleavage is present both within the gorge of Indian Creek and up slope along Ashhopper Hollow, Harris Hollow and Whaley Brook (Pippen Hollow). Within the Indian Creek, gorge the second cleavage ( $S_2$  in Figures 29c, 29d) crenulates the first bedding-thrust parallel cleavage. In thin-section (see Figures 29c, 29d), the crenulations clearly fold the thrust parallel cleavage and have also slightly rotated the associated quartz ribbons (Means, 1982). The crenulation cleavage strikes north  $30^\circ$  to  $50^\circ$  east, dips  $45^\circ$  to  $50^\circ$  southeast and is spaced at about .25 centimeter (.5 inch) intervals. Within the up slope hollows, the second cleavage ( $S_2$  in Figure 30a) forms as a spaced parallel cleavage containing smooth cleavage domains (see Figure 30a). The cleavage strikes northeast and dips  $35^\circ$  to  $65^\circ$  southeast and is oriented upwards facing with respect to bedding, (Shackelton, 1950; Diegel, in press). In thin-section (see Figure 30b), the cleavage ( $S_2$  in Figure 30b) is dark, continuous, closely spaced and has a smooth or planar shape (Borradaile et al., 1982). The cleavage is most common in the finer-grained layers and is often slightly refracted by the coarser-grained layers.

Figure 30. Photographs of deformational features exposed at Ashhopper Hollow and in Canah Hollow.

a. Hand sample photograph of  $S_2$  cleavage at Ashhopper Hollow. The cleavage is spaced, parallel, and smooth; the cleavage is oriented upwards facing to bedding ( $S_0$ ).  $S_1$  is not exposed at this location.

b. Thin-section photograph of  $S_2$  cleavage at Ashhopper Hollow. The cleavage is dark, continuous, closely spaced and has a smooth or planar shape.  $S_1$  is not exposed at this location. Bar scale is 1 mm in length.

c. Outcrop photograph of minor folds within the Unincoi horse southeast of Canah Hollow. The folds are open and concentric with the fold axes trending south  $25^\circ$  west and plunging  $5^\circ$  southwest.

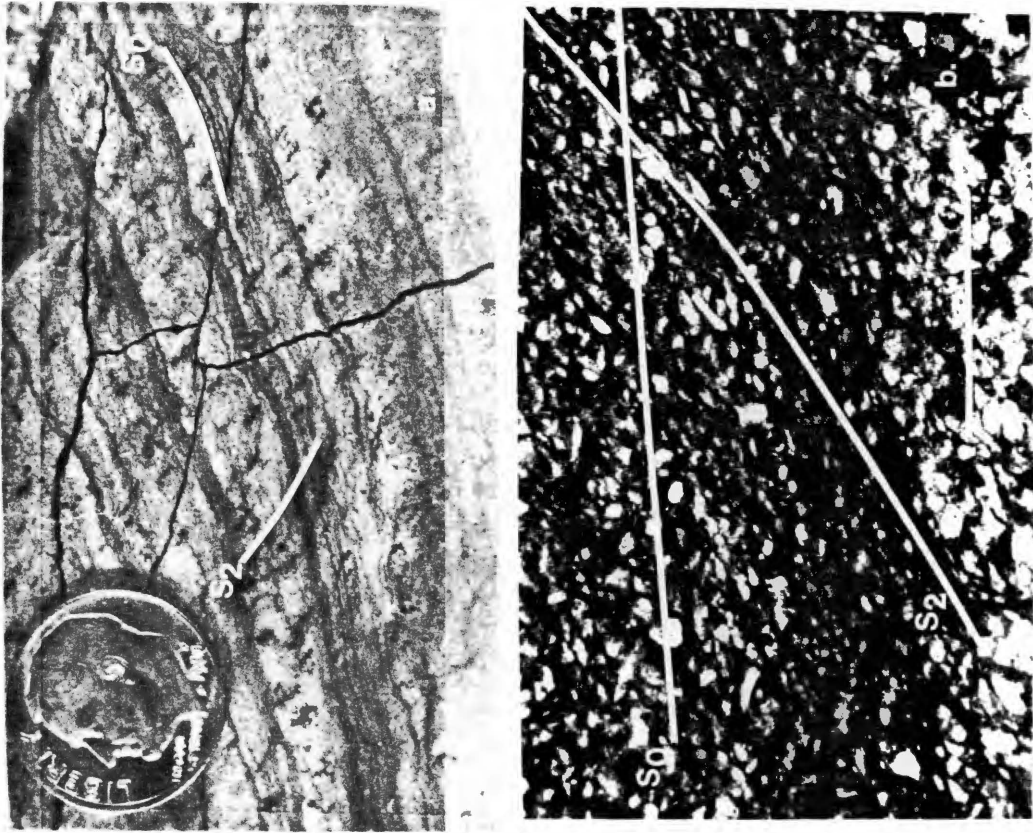
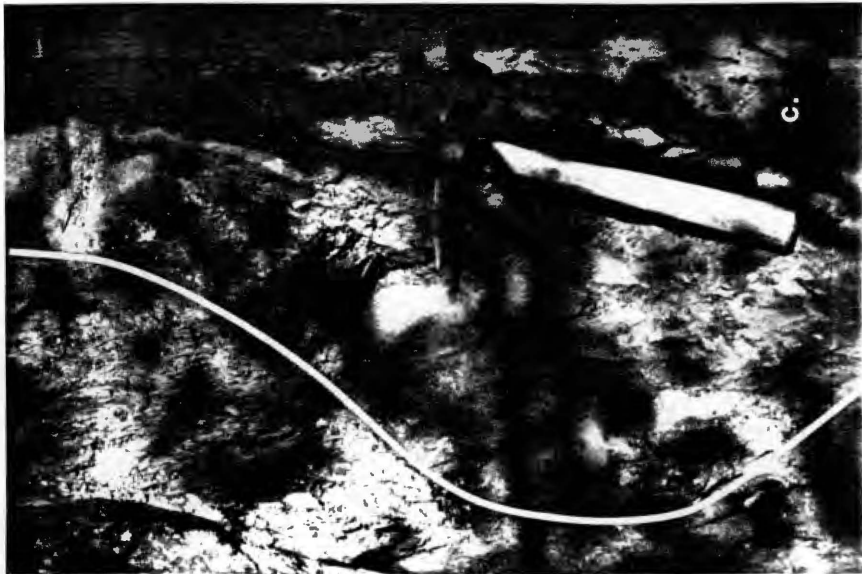

Figure 30.



## Canah Hollow

Along the southwestern side of the mass of Unicoi south of Canah Hollow several 4 to 10 centimeter (2 to 5 inch) thick sandstone lenses are folded (see Figure 30c). The folds are open and concentric, and their axes trend south  $25^{\circ}$  west and plunge  $5^{\circ}$  southwest. Throughout most of the folded sandstone layer minor fractures are oriented perpendicular to bedding. Near the hinges of the fold, the number of fractures increases, the fractures are axial planar, and in some cases duplicate the layer. Shales surrounding the sandstone lens are both highly crumpled and gently warped. Around the outer arcs of the sandstone folds, the shale layers are either parallel to the bounding quartzite units or gently warped around the sandstone lens. Beneath the inner fold arcs, the shales either dome up and mimic the curvature of the folded sandstone or are crumpled into a series of disharmonic folds that have small amplitudes and wavelengths. Slickenfibers trending subaxial planar are present on several bedding planes.



## CHAPTER VII

### DISCUSSION

#### Introduction

This thesis examines three questions concerning the structural evolution of Buffalo Mountain and the Blue Ridge front of northeast Tennessee:

1. Are thrust sheets emplaced during a single generation of thrusting or during multiple generations of thrusting?
2. Are thrust sheets emplaced from the hinterland to the foreland or from the foreland to the hinterland?
3. What is the sequence of thrust fault imbrication within the Buffalo Mountain thrust sheet?

#### Number of Thrust Generations

A single generation of thrusting produces thrust faults that usually cut up stratigraphic section and place older rocks over younger rocks (Dalhstrom, 1970). Multiple generations of thrusting would, however, produce thrusts that cross-cut and displace each other, thrusts that cut down stratigraphic section and thrusts that place younger

rocks over older rocks (Fox, 1969; Dahlstrom, 1970; Boyer and Elliott, 1982).

Previous work suggests that the frontal margin of the Tennessee Blue Ridge has experienced two phases of deformation including two episodes of thrusting. Rodgers (1953, 1970), Hamilton (1961), Hadley and Nelson (1971), and King (1964), indicated that deformation in the southeastern Tennessee Blue Ridge occurred during two separate events. More recently, Keller (1977, 1980), working 50 kilometers (80 miles) southwest of Buffalo Mountain, stated that a second generation of thrusting is responsible for the emplacement of the Great Smoky thrust and for the anomalous younger over older stratigraphic age relations along other faults. Thus, Keller (1980, p. 273) concluded that polyphase thrusting associated with Taconic and Alleghenian deformation was a well-established part of the structural history of the central-east Tennessee Blue Ridge.

Around the Mountain City window in northeast Tennessee, structural interpretations concerning the number of deformational sequences and thrusting episodes is less clear. According to King and Ferguson (1960), emplacement of the undeformed Shady Valley thrust sheet over already deformed rocks occurred during the beginning of orogenesis. Continued deformation caused the Buffalo Mountain/Stone Mountain thrust family to truncate or split

from and override the Shady Valley thrust sheet. This scenario implies multiple phases of deformation with only one episode of out-of-sequence "break-back" thrusting. Rodgers (1970) suggested that the Blue Ridge of northeast Tennessee showed signs of two phases of deformation. The first phase of deformation occurred during the Ordovician and produced the metamorphic fabrics found within the Spruce Pine synclinorium. The second phase of deformation occurred during the Late Carboniferous or Permian and resulted in the emplacement of all the major faults.

Although Ordway (1949, 1959) does not specifically comment on the number of deformational phases affecting Buffalo Mountain, he implied that some type of deformation occurred before the emplacement of the Buffalo Mountain sheet. His cross-sections showed the Buffalo Mountain thrust cutting down stratigraphic section, as a result of the thrust developing across a fold or through previously tilted strata (see Figure 2, section D, page 7). Similarly Bearce (1966, 1969), working a few kilometers (miles) southwest in the Bald Mountains, also showed the Buffalo Mountain thrust cutting down stratigraphic section.

Direct and indirect observation of the Buffalo Mountain thrust, carried out during the current study, however, documents that the Buffalo Mountain thrust cuts up stratigraphic section through both the hanging wall and foot wall rocks. For example, along TN 106 the Buffalo

Mountain thrust plane is parallel with the hanging wall strata of the upper Unicoi and cuts slightly up-section through the foot wall Knox Group (see Figure 26a, page 70). Also, the Pinnacle thrust exposed along TN 81 S/107 E northwest of Erwin, Tennessee clearly cuts up-section through the Hampton and Erwin formations (see Plate 1). Cross-sections showing the orientation of the Buffalo Mountain thrust versus hanging wall and foot wall dip (see Figure 31 and 32, sections A-A', B-B', C-C', D-D') illustrate that the Buffalo Mountain thrust consistently dips more steeply than both the hanging wall and foot wall rocks. This relationship indicates that the Buffalo Mountain thrust cuts up stratigraphic section throughout the Buffalo Mountain area.

Geologic mapping of the northeastern Tennessee Blue Ridge (Rodgers, 1953; Hardeman, 1966; King and Ferguson, 1960) shows that thrust faults in this region do not cross-cut each other and that they consistently place older rocks over younger rocks. At Canah Hollow near Erwin, Tennessee, however, thrusting has produced an apparent younger over older stratigraphic arrangement (see Figure 17, page 54). The southwestern end of the Pinnacle sheet, in this area, is eroded to expose an underlying section of Shady Dolomite. Both the Pinnacle sheet and Shady section are folded into a northeast plunging anticline-syncline pair. Along its southeastern edge, the section of Shady is

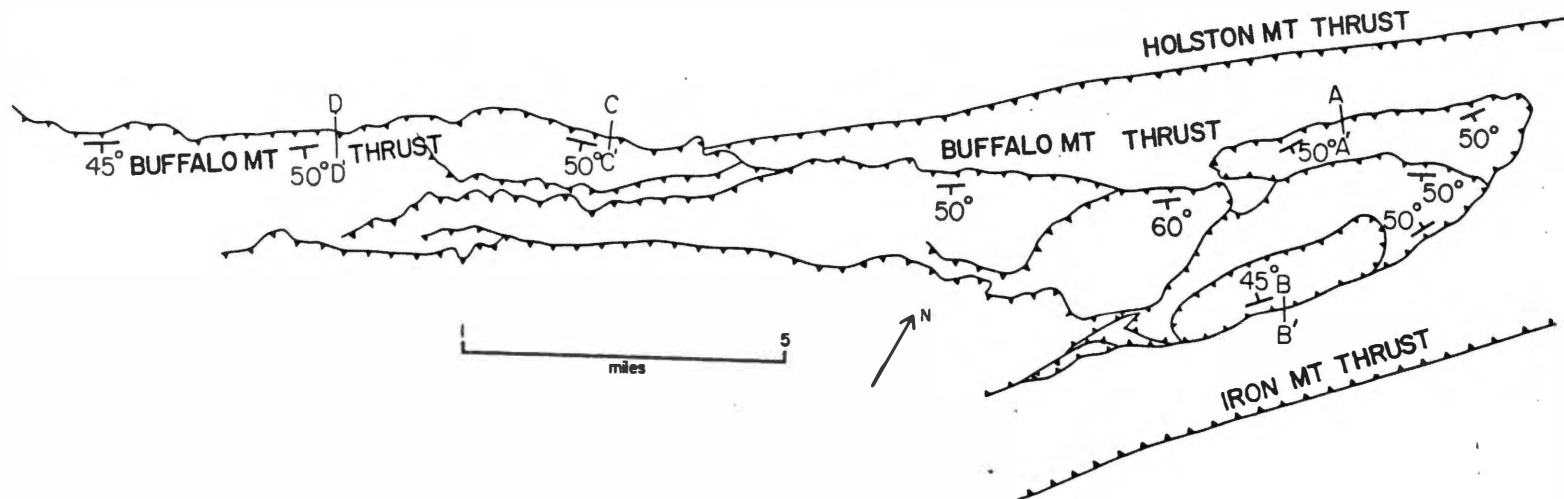

Figure 31. Structure map of the Buffalo Mountain thrust sheet showing the orientation of the Buffalo Mountain thrust and related imbricates. Orientation data was determined by near surface structure contouring of fault traces. Cross-section lines correspond to Figure 32. (from Ordway 1949, 1959; Bearce, 1966, 1969; and Diegel, in press a and b).

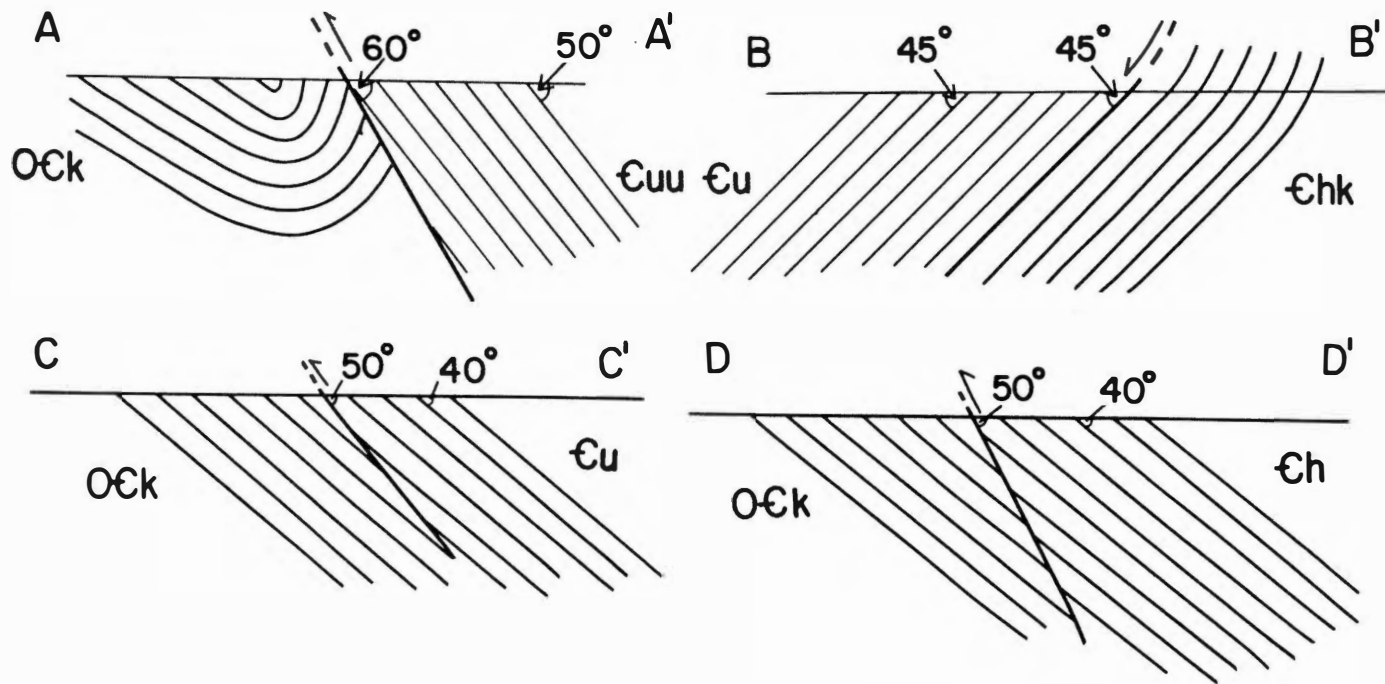

Figure 32. Schematic cross-sections through the Buffalo Mountain thrust showing the relationship between the thrust and foot wall and hanging wall stratigraphy. Section lines correspond to Figure 31.

(Holston Mountain thrust sheet) and by a large mass of Unicoi. The mass of Unicoi is completely enveloped by two thrusts. Bedding within the mass strikes north 35° east and dips 70° northwest beneath the Shady.

Ordway (1949, 1959) proposed two structural interpretations of Canah Hollow (see Figure 33). In both interpretations, the Shady Dolomite is considered to be part of the Intermediate sheet that is folded along with the Pinnacle sheet. The first interpretation suggested (see Figure 33a) that the southeastern mass of Unicoi is part of the Pinnacle sheet. Thus, the Pinnacle thrust underlies all of the Unicoi surrounding Canah Hollow and the Shady is exposed as a window through the Pinnacle sheet. The second interpretation proposed (see Figure 33b) that the mass of Unicoi is a large slice caught between the Buffalo Mountain thrust and the Intermediate sheet. Ordway (1949, 1959) felt that the first interpretation was mechanically simpler, but favored the second interpretation based on the geometry of the structure. Because the Shady is considered to be part of the Intermediate sheet, Ordway's cross-sections (see Figure 33) show the Pinnacle thrust cutting down stratigraphic section through first the Shady and then the Unicoi. Thus, both of Ordway's interpretations are in contradiction to observations made during this study. However, by examining the Canah Hollow area down its structural plunge (Mackin, 1959) and assuming

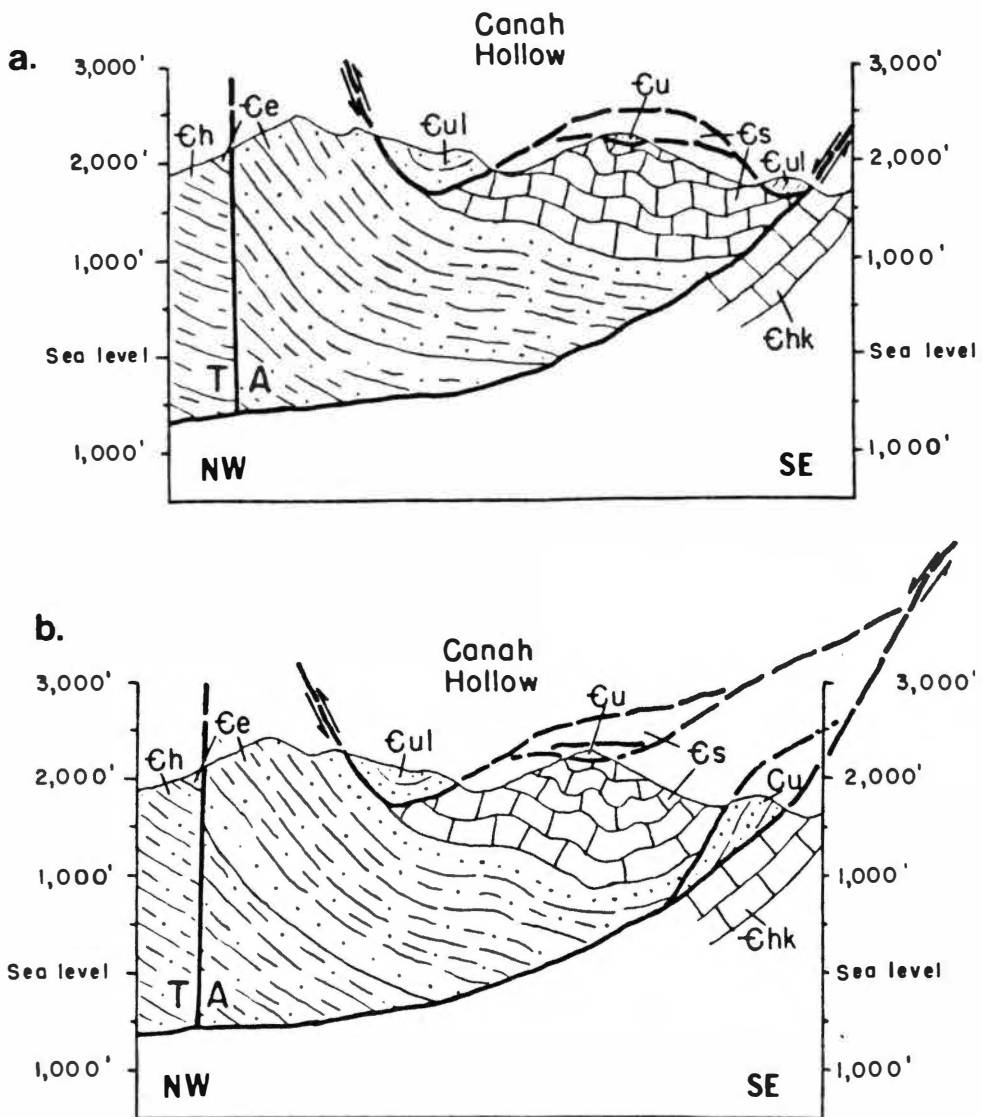

Figure 33. Structural interpretations of Canah Hollow by Ordway (1949, 1959).

a. The southeastern mass of Unicoi is part of the Pinnacle sheet.

b. The southeastern mass of Unicoi is a large slice caught between the Buffalo Mountain thrust and the Intermediate sheet. (from Ordway, 1949, 1959).



that the section of Shady is not part of the Intermediate sheet, I interpret the structure of Canah Hollow to be a foreland dipping duplex (see Figure 34). The section of Shady is a horse block wedged between the overlying Pinnacle sheet and the underlying horse of Unicoi. The floor thrust of the duplex merges with the roof thrust beneath the Pinnacle sheet, with the roof thrust continuing to cut up stratigraphic section as the Pinnacle imbricate. The initial idea for this interpretation is from King et al., (1944, Plate 1, cross-section E-E'), which shows the block of Unicoi southeast of Canah Hollow as a horse.

This interpretation of Canah Hollow provides the interesting age relationship of older Unicoi thrust over, and under, younger Shady. This relationship might suggest the possibility of multiple generations of thrusting. However, a simpler model of progressive deformation during a single thrust episode, producing hanging wall and foot wall horses can also explain the unusual age relationships within Canah Hollow (see Figure 35)

An additional structural complexity at Canah Hollow involves a small mass of Unicoi located within the section of Shady. By assuming that the Unicoi mass is a klippe or extension of the Pinnacle thrust, a structure contour diagram of the Pinnacle thrust indicates that the thrust plane is folded into a southwest-dipping anticline (see Figure 36). Direct measurement of the Shady strata,

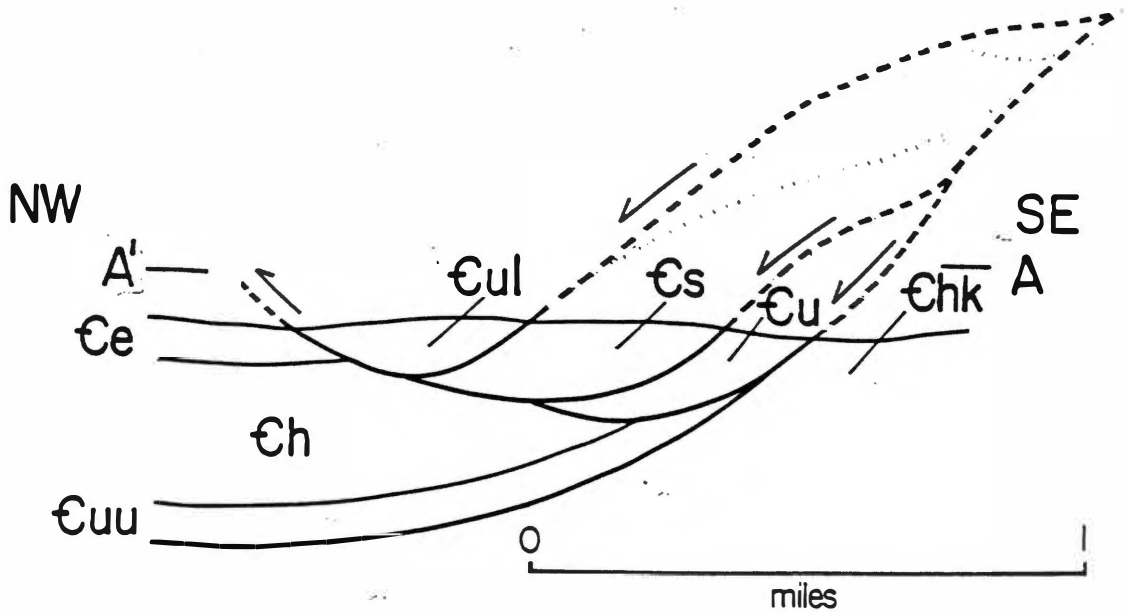

Figure 34. Structural cross-section of Canah Hollow. Notice that the section of Shady is a horse block wedged between the overlying Pinnacle sheet and the underlying horse of Unicoi. The structure is a foreland-dipping duplex. The floor thrust merges with the roof thrust beneath the Pinnacle sheet, with the roof thrust continuing to cut up stratigraphic section as the Pinnacle imbricate.

Figure 35. Sequential development of the foreland-dipping duplex at Canah Hollow. (T<sub>1</sub>) During the initial emplacement of the Buffalo Mountain thrust sheet, a section of Shady was plucked from the foot wall. (T<sub>2</sub>) The foot wall horse of Shady was carried along with the Buffalo Mountain sheet. (T<sub>3</sub>) A hanging wall horse of Unicoi developed within the thrust sheet, possibly as the Buffalo Mountain thrust ramped upward. (T<sub>4</sub>) Movement of the Buffalo Mountain thrust sheet allowed the Shady horse to move over the Unicoi horse. (T<sub>5</sub>) The Shady-Unicoi horses were carried up stratigraphic section by the Buffalo Mountain thrust sheet, placed against the Honaker Dolomite, and later folded, with the Buffalo Mountain sheet, into a foreland dipping attitude.

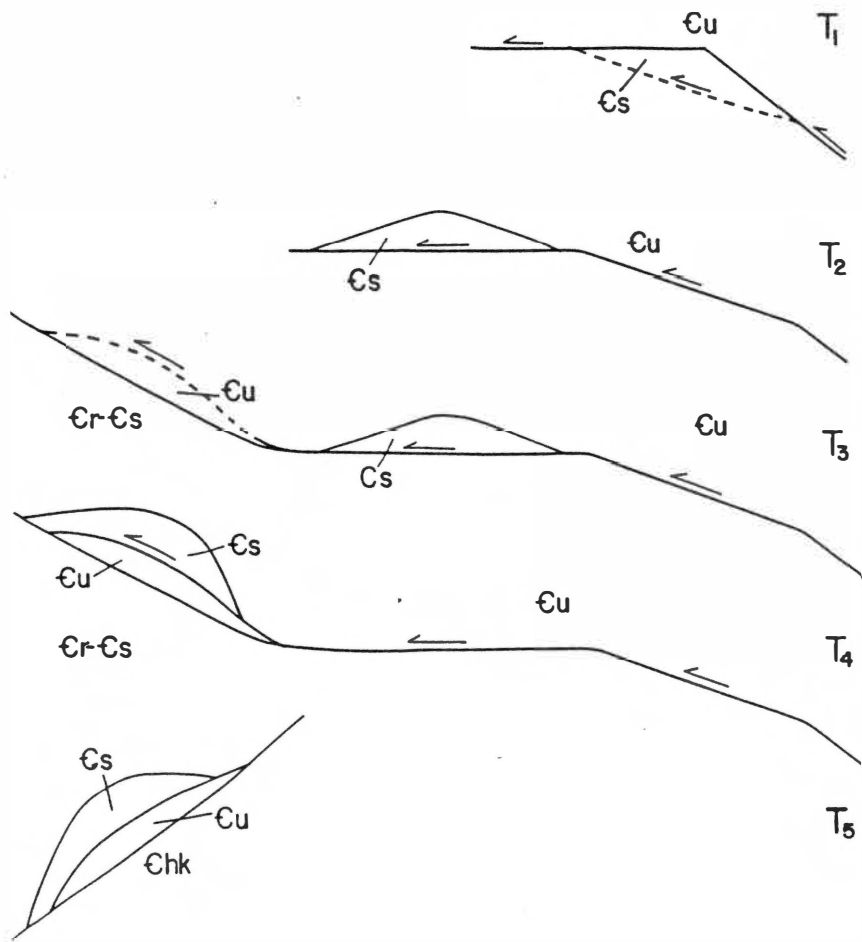

Figure 35.

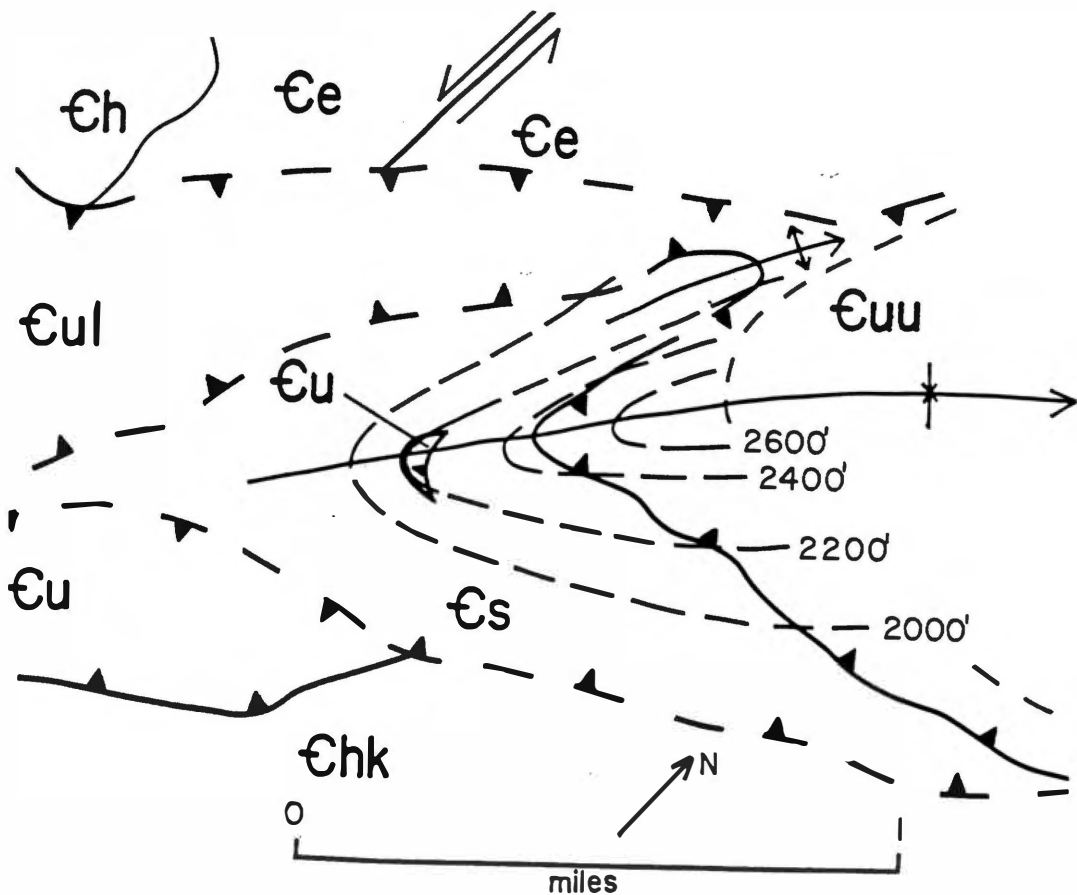

Figure 36. Structure contour map of the Pinnacle imbricate sheet assuming that the Unicoi klippe is an extension of the Pinnacle sheet. The structure contour map indicates that the Pinnacle imbricate thrust plane is folded into a southwest-dipping anticline. Direct measurement of the foot wall Shady reveals that the Shady is folded into a northeast-plunging syncline.

however, reveals that the Shady is actually folded into a northeast-plunging syncline (see Figure 17, page 54, and Plate 1). This relationship obviously presents a problem.

Ordway (1949, 1959) explained the position of the small mass of Unicoi by assuming a broad arching or folding of strata into an anticline with a thrust developing at a low angle across the fold. The minor thrust then repeats a section of Shady and drags a slice of Unicoi into its present position. I feel, however, that this interpretation contains several problems. First, because Ordway (1949; 1959) assumed that the thrust developed from an anticline, a second deformational event is necessary to refold the Shady into its present synclinal orientation. Although this scenario is possible, no other evidence of refolding is present in the Buffalo Mountain area. Second, if refolding had occurred after thrusting, then the thrust should be folded. However, Ordway's (1949, 1959) map of Canah Hollow shows the thrust as an unfolded planar feature (see Figure 16, page 52).

Rodgers (personal communication) suggested that after initial thrusting of the Unicoi over the Shady a second thrust truncated and displaced the first thrust. Movement along the second thrust placed younger Shady over older Unicoi (see Figure 37). This idea, although geometrically possible, is probably not a typical structural style

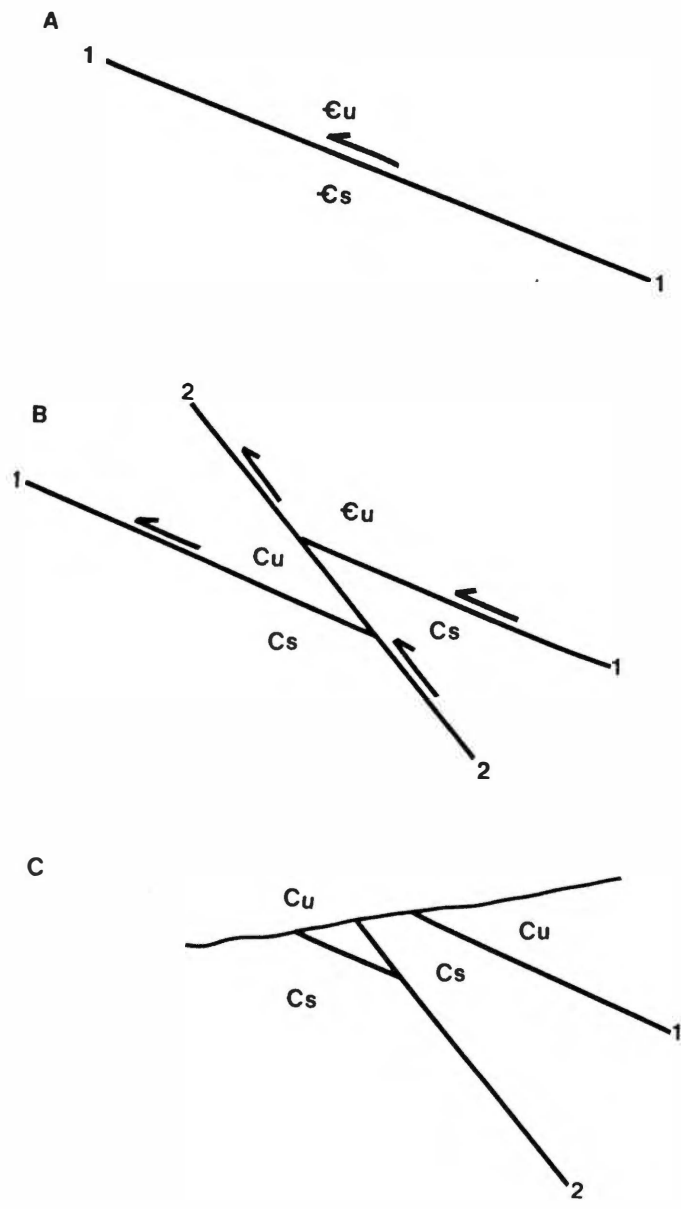

Figure 37. Multiple thrust model to explain the position of the Unicoi klippe at Canah Hollow. (A) Unicoi thrust over Shady along thrust 1. (B) Thrust 1 cut and displaced by higher angle thrust 2. (C) Erosion through the thrust pair exposes the Unicoi klippe. (from Rodgers, personal communication).

(Dalhstrom, 1970), because no where else in the Buffalo Mountain area are cross-cutting thrusts observed.

Detailed mapping and examination of the Shady yields three other possible explanations for the position of the small mass of Unicoi within Canah Hollow. In the interpretations the small mass of Unicoi is assumed to have originally belonged to the Pinnacle sheet. The first explanation also assumes that a consistent internal stratigraphy exists within the Shady. In Canah Hollow the apparent internal stratigraphy of the Shady is from bottom to top: lower white, lower blue, ribboned, middle blue, upper white and upper blue. The map pattern of these units (see Figure 38), and the resulting cross-section (see Figure 39), indicates that a pair of contractional and extensional faults, one of which coincides with Ordway's (1949, 1959) low angle cross-anticline thrust, have positioned the mass of Unicoi between the units of Shady. Extensional features are common within thrust sheets are common (Elliott, 1976, 1977). The extensional faults at Canah Hollow could be a result of the Buffalo Mountain thrust sheet moving over a sub-thrust ramp. However, this interpretation is limited by the quality and quantity of rock exposure, the difficulty of determining rock types due to interbedding, and by the lack of exposed fault surfaces and fault related fabrics.



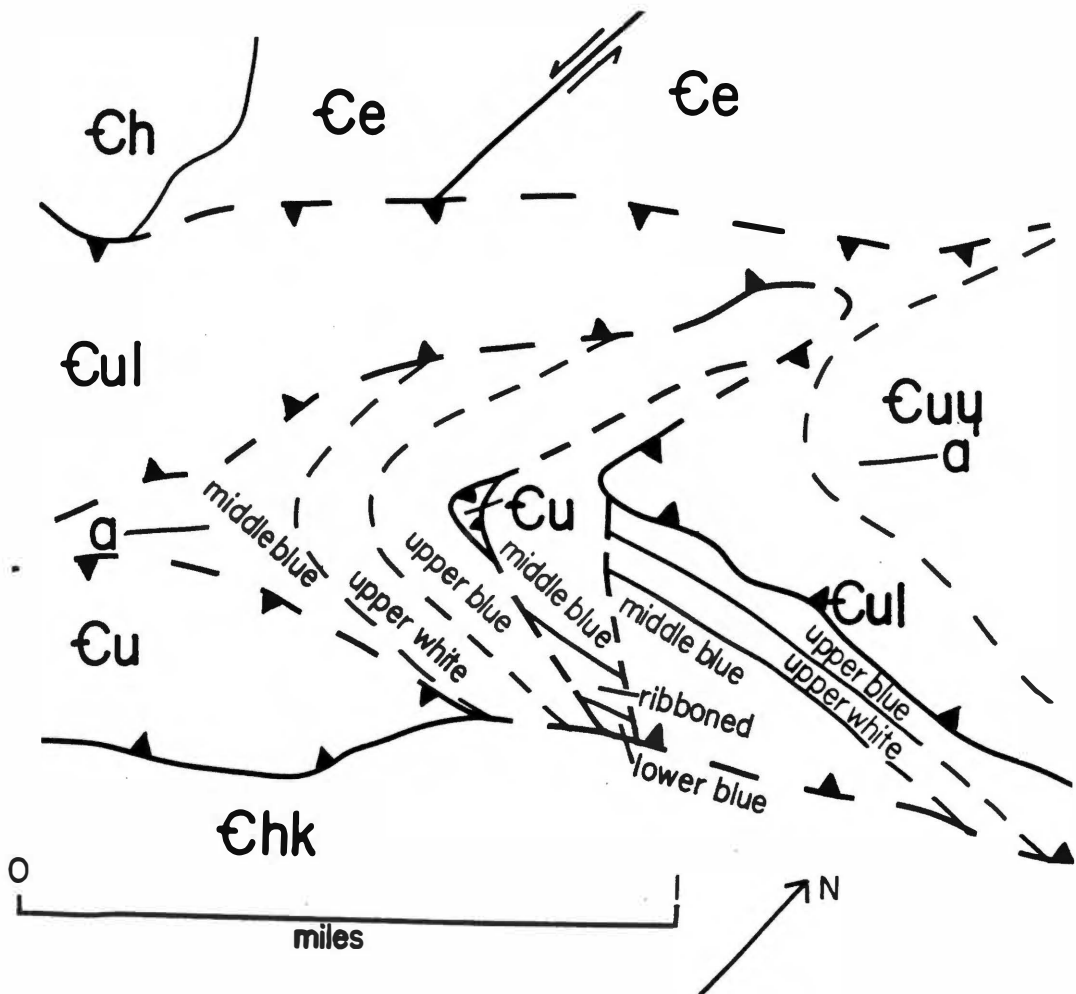

Figure 38 Geologic map of Canah Hollow assuming a consistent internal stratigraphy. The stratigraphy is from bottom to top: lower white, lower blue, ribboned, lower blue, lower white.

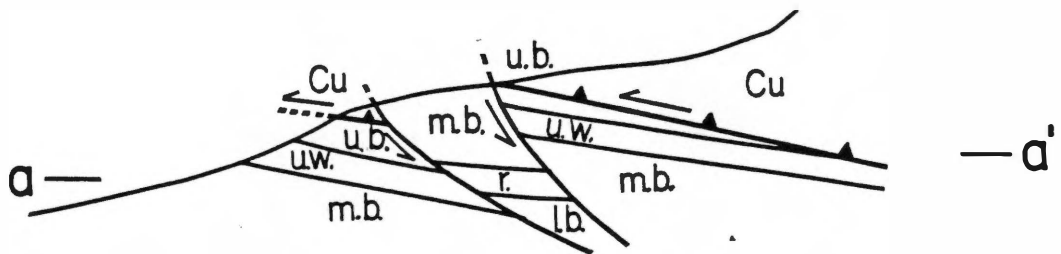

Figure 39. Structural cross-section of Shady in Canah Hollow based on Figure 38. Position of Unicoi klippe explained by a pair of contractional and extensional faults.

The second and third explanations assume that rather than a consistent internal stratigraphy, the Shady is composed of a mosaic of blue, white and ribboned dolomite (Rodgers, 1948). Thus, stratigraphic relationships cannot be used to outline structural relationships (see Figure 40). Instead, two erosional models, based on three lines of circumstantial evidence are presented. The three lines of circumstantial evidence are:

1. The klippe of Unicoi on the ridge east of Canah Hollow is composed of highly resistant quartzite, the rocks forming the edge of the Pinnacle sheet above the Unicoi klippe, however, are made of easily erodible shales and sandy shales.

2. The Shady Dolomite in northeastern Tennessee often contains caves. One cave, approximately 250 feet long, is located on the southeastern edge of the ridge east of Canah Hollow.

3. Differential weathering along joint and fracture planes within the Shady often produces "a fantastic variety of pinnacles and crevices with a relief of 10 to 100 feet" (King et. al, 1944, p. 25). Often these pinnacles fall or collapse due to a lack of support.

Thus (see Figure 41), after the Unicoi was initially thrust over the Shady along the Pinnacle thrust, weathering and erosion incised the Unicoi along weak shale zones and exposed the underlying Shady. Continued weathering and

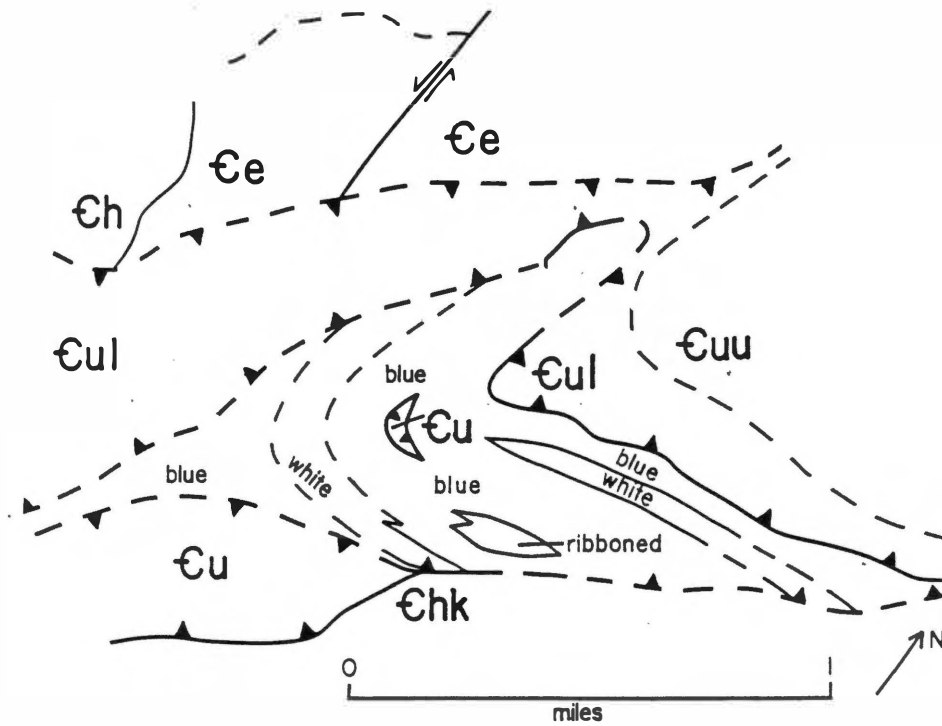

Figure 40. Geologic map of Canah Hollow assuming a complex three-dimensional mosaic of blue, white, and ribboned facies within the Shady.

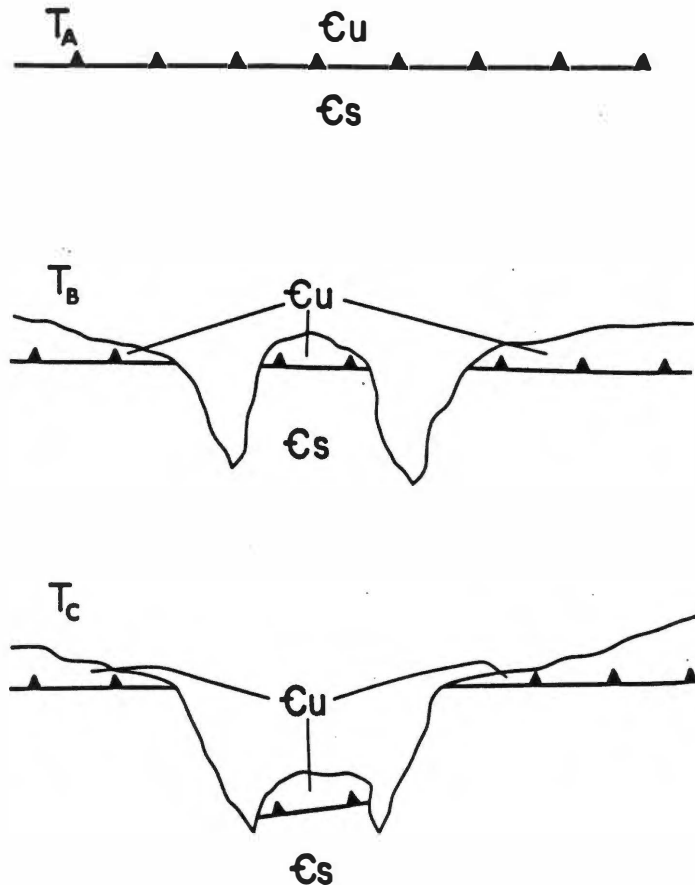

Figure 41. Erosional collapse model to explain the position of the Unicoi klippe at Canah Hollow. ( $T_A$ ) Unicoi is thrust over Shady along the Pinnacle thrust. ( $T_B$ ) Erosion incises Unicoi and exposes the underlying Shady. Continued weathering and erosion along joints and fractures within the Shady produces a pinnacle or butte of Shady capped by a klippe of Unicoi. ( $T_C$ ) Overstepping of the sides of the pinnacle, or cavern development, causes the pinnacle to collapse and position the klippe of Unicoi below the trace of the Pinnacle imbricate.

erosion along joints and fractures within the Shady produced a pinnacle or butte of Shady capped by a resistant klippe of Unicoi. Overstepping of the sides of the pinnacle, or cavern development within the pinnacle, caused the pinnacle to collapse and position the klippe of Unicoi below the trace of the Pinnacle imbricate. The third idea is that, instead of pinnacle formation and collapse, the Unicoi klippe was emplaced simply by mass wasting. During erosion the mass of Unicoi became detached from the Pinnacle imbricate sheet and slid down slope.

All of these models provide explanations for the structural position of the klippe of Unicoi within Canah Hollow. The lack of exposed fault surfaces and fault related fabrics, combined with the confusion associated with the Shady's stratigraphy, lead me to favor one of the erosional models to explain the position of the Unicoi klippe.

In summary, within the Buffalo Mountain area thrust faults cut up stratigraphic section, place older rock over younger rock, (with only one exception at Canah Hollow), and do not cross-cut and displace other thrusts. Thus, I conclude that the Buffalo Mountain area and possibly all of the northeast Tennessee Blue Ridge has experienced only one episode of thrust faulting.

This conclusion raises two questions. First, why are the number of thrust episodes in the south and central Blue

Ridge of Tennessee apparently different from the northeastern Tennessee Blue Ridge? Rodgers (1970) suspects that the difference in structural styles is related to the differences in materials involved in thrusting. Within most of the northeastern thrust sheets, basement is commonly present but the south-central thrust sheets are composed almost entirely of sediments with basement appearing only on the extreme southeastern side of the sheets (Rodgers, 1970). Woodward (1986), however, proposes that the second generation of thrusts are not thrusts but rather, a series of extensional faults that are symmetrically arrayed over folds in the crystalline Great Smoky sheet.

Second, when did the single event of thrusting in the northeast Tennessee Blue Ridge occur? Middle Ordovician conglomerates containing pebbles and cobbles of Lower Cambrian quartzites and sandstones to Lower Ordovician limestones suggests some type of orogenic disturbance during the Early Paleozoic (Taconic), (Kellberg and Grant, 1956). However, the Great Smoky fault, which interconnects with the Buffalo Mountain thrust, places Cambrian Chilhowee over Mississippian Pennington. This relationship indicates that thrusting in the northeast Tennessee Blue Ridge occurred during the Late Paleozoic (Alleghenian).

## Sequence of Thrust Sheet Emplacement

Several ideas exist concerning the order or sequence of thrust sheet emplacement in northeast Tennessee. The main ideas are:

1. Foreland to hinterland progression of sheets based on the Gilluly (1960) Goat Ridge model;
2. Foreland to hinterland breakback emplacement of thrust sheets (Milici, 1975; Harris and Milici, 1977);
3. Hinterland to foreland progression of thrust sheets with folding caused by thrust sheet emplacement (Boyer and Elliott, 1982; Diegel, 1986, b).

Rodgers (1970) suggests that because the highest thrust sheet apparently cuts off the rear of the lower sheets, thrusting in northeast Tennessee progressed from the foreland to the hinterland. Furthermore, Rodgers (1970) cites the Goat Ridge model of Gilluly (1960) as the driving mechanism behind thrusting in the northeast Tennessee Blue Ridge.

According to Gilluly (1960) folding and thrusting are simultaneous processes, with thrust zones acting as "sliding sledges" dragging adjacent underlying rocks along during thrust movement. With continued thrust movement, the fault surface and surrounding rocks become bent or



folded with folding also aided by regional compression. With increased folding the fault is unable to slip in the folded position and a new straighter fault breaks above the original thrust across the back of the fold. This new sheet is in turn folded and eventually yields to the next overlying thrust.

Although they do not specifically refer to Gilluly (1960), King and Ferguson's (1960) explanation of thrust emplacement in northeast Tennessee is based on the same simultaneous folding and faulting idea. Specifically, King and Ferguson (1960) felt that the Shady Valley sheet overrode the previously deformed rocks of the Valley and Ridge and were later truncated and overridden by the Buffalo Mountain and Stone Mountain family sheets.

Ordway (1949, 1959) did not comment on the regional thrust sequence but he did postulate that the Buffalo Mountain thrust developed across folded strata. In his model, Ordway (1949, 1959) theorized that an anticlinal fold, overturned to the northwest, developed in the Chilhowee due to compression. With continued compression the Buffalo Mountain thrust sheet broke across the back limb of the fold.

Milici (1977) and Harris and Milici (1977) also suggested that thrust sheet emplacement in the Appalachians occurred in a foreland to hinterland "break-back" fashion. This theory was based on Milici's (1975) idea that the

relative ages, or times of last movement of faults and folds could be determined where faults and folds intersect. Younger faults, he felt, are those that either continue to move after older faults become stabilized, or lie unfolded in a folded terrain. Milici (1975) subsequently explained, that the older structures, those that died first, are to the west (foreland).

In all of the foreland to hinterland thrust models proposed above, problems surround the downwards facing thrust sheets in the Limestone Cove inner window and the folded shape of the Holston Mountain and Buffalo Mountain thrust sheets. Gilluly (1960) and Gilluly and Gates (1965) argued that eyelid windows such as Limestone Cove are diagnostic features of hindwards thrusting coupled with simultaneous folding. Detailed work by Diegel (in press a, and b) shows that the Limestone Cove inner window is composed of five foreland dipping imbricates with trailing branch lines in a common roof thrust (see Figure 2, section F, page 7). In addition, cleavage appears to have formed during the thrusting of each slice and was then rigidly rotated towards the foreland by the emplacement of successively lower more foreland slices. The Goat Ridge model (Gilluly, 1960) and a polyphase model of thrusting followed by folding (Roeder et al., 1978a) both require the presence of a later upwards facing cleavage which is not found in the Limestone Cove inner window (see Figure 42).

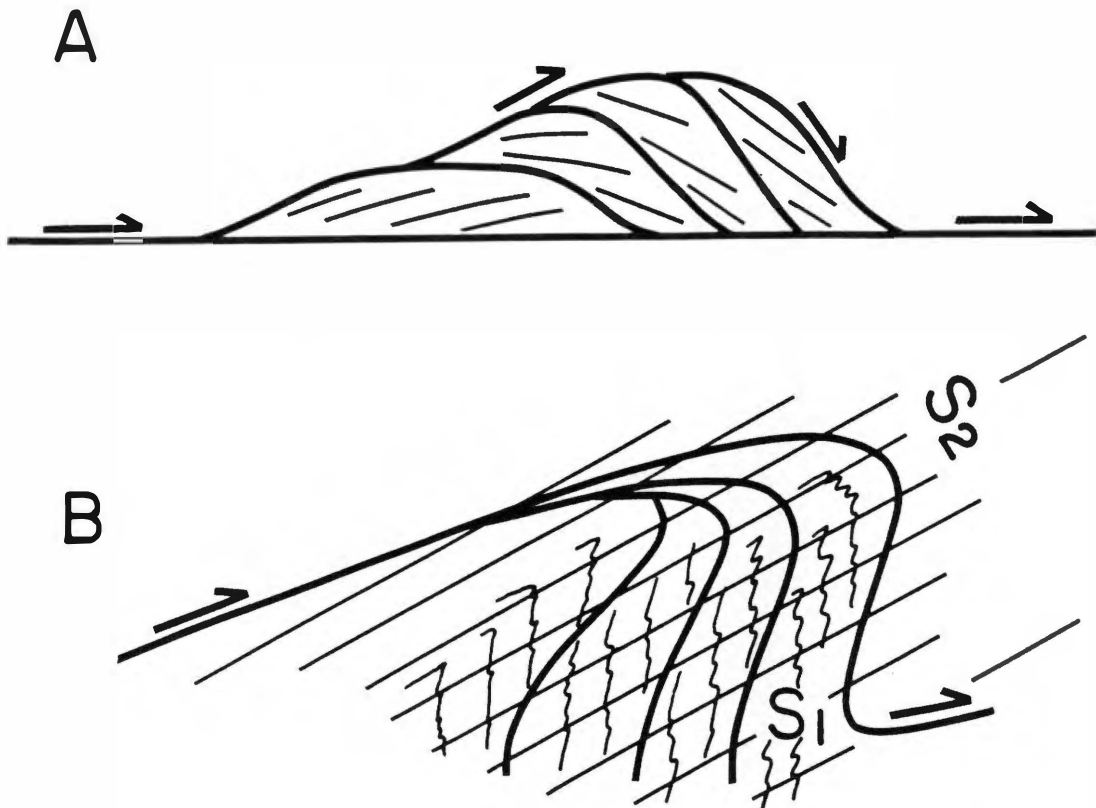

Figure 42. The orientation of small scale structures in foreland-dipping thrust networks.

a. Rigged rotation of thrust related cleavage in a foreland dipping duplex formed by a single phase of hinterland to foreland in-sequence thrusting. Cleavage is asymptotic to the imbricates.

b. Reforlding of thrust related cleavage in a polyphase or Goat Ridge type model. Two cleavages are formed:  $S_1$  which is related to initial thrusting along the imbricates, and  $S_2$ , which folds or crenulates  $S_1$ , and is related to a later folding event. Small scale structures in the Limestone Cove inner window are of type a. (from Diegel, in press a and b).

Jones (1971, modified from Verrall, 1968) explained that folded thrust sheets are an expected result of hinterland to foreland thrusting. Figure 43 shows that movement on a step-fault folds the overlying thrust sheet, including the fault. Continued emplacement of successively lower more foreland step-thrusts superimposed on one another, accentuates the folding of the higher, more hinterland thrust sheet.

The orientation of upwards-facing cleavage above the foreland-dipping Buffalo Mountain thrust along the southeast side of the synclinally folded Buffalo Mountain thrust sheet (see Figures 29c and 29d, page 82, Figures 30a and 30b, page 86, and Plate 1) suggests that the cleavage formed during the folding of the Buffalo Mountain sheet (Shackleton, 1958; Diegel, in press, b). Furthermore because this cleavage crenulates an earlier thrust related cleavage (see Figures 29c and 29d, page 82), it seems logical to suggest, that the Buffalo Mountain thrust sheet has been folded after its emplacement. Furthermore, folding is probably a result of the emplacement of structurally lower more foreland units such as the Limestone Cove duplex and Pulaski sheet.

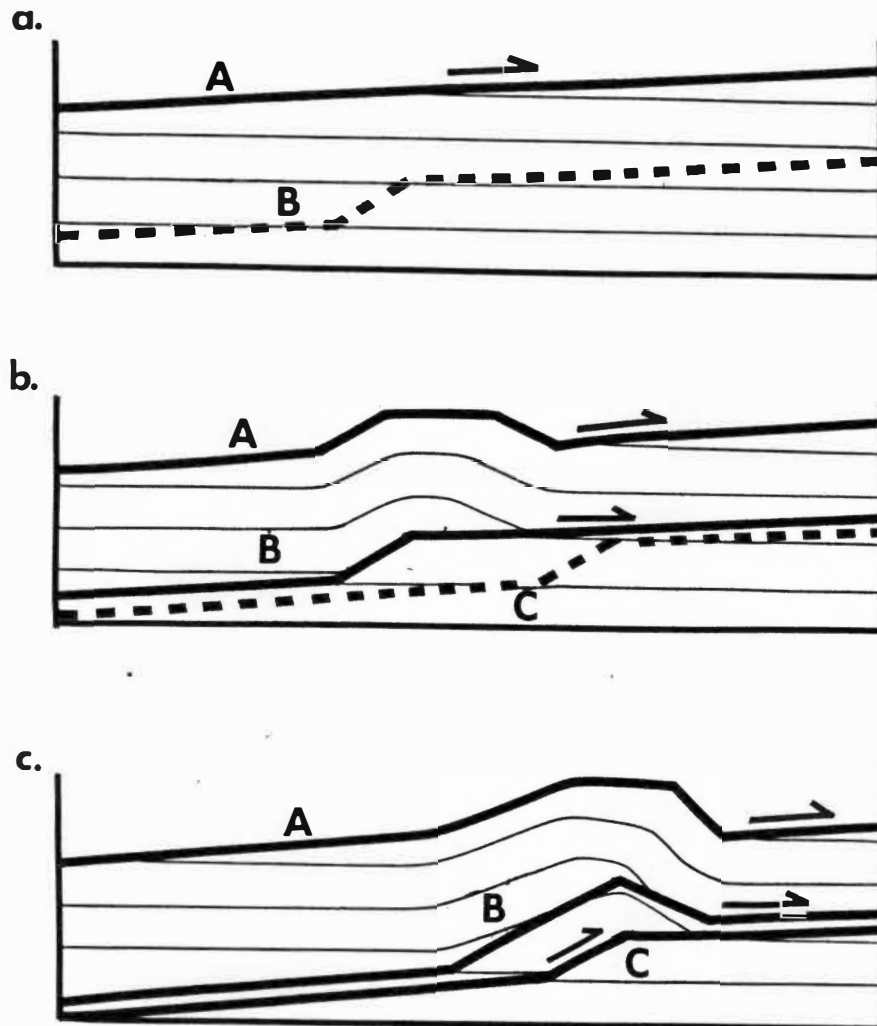

Figure 43. Development of folded faults during a single phase of hinterland to foreland in-sequence thrusting.

a. Planar fault (A) is in place, incipient step-fault (B) begins to form.

b. Movement on step-fault (B) folds the overlying sequence, including fault (A). Incipient step-fault (C) begins to form.

c. Movement on (C) folds fault (B) and accentuates folding of fault (A). (from Jones, 1971).

Figure 44 is a schematic sequential diagram showing the emplacement of the Buffalo Mountain sheet, the Holston Mountain sheet, the Limestone Cove duplex, and the Pulaski sheet.

The idea of thrust sheet folding due to duplex emplacement belongs to Boyer and Elliott (1982) who convincingly argued that the emplacement of the Doe Ridges hinterland dipping duplex was responsible for the warping of the Holston Mountain thrust sheet. The present hypothesis is slightly different because it requires the emplacement of the Pulaski sheet to complete the folding of the Buffalo Mountain/Holston Mountain thrust pile.

The above arguments lead me to conclude that thrust sheet emplacement in the Buffalo Mountain area and probably in all of the northeast Tennessee Blue Ridge has occurred in a hinterland to foreland fashion. In addition, the folding of the Buffalo Mountain thrust is due to the vise effect caused by the emplacement of the structurally lower, more foreland Limestone Cove duplex and Pulaski sheet.

#### Sequence of Thrust Sheet Imbrication

Imbrication within a thrust sheet occurs either from the foreland to the hinterland, or from the hinterland to the foreland. Dahlstrom (1970) felt that it is possible to

Figure 44. Schematic sequential diagram showing the emplacement of the Buffalo Mountain sheet, the Holston Mountain sheet, the Limestone Cove duplex, and the Pulaski sheet. During  $T_1$  the Buffalo Mountain thrust sheet was emplaced. During the emplacement of the Buffalo Mountain sheet the Shady and Unicoi horses which eventually become part of Canah Hollow were formed. During  $T_2$  the Holston Mountain sheet formed and was emplaced beneath the Buffalo Mountain sheet. Movement of the Buffalo Mountain/Holston Mountain thrust pile caused a set of imbricates to cut upward to join the Holston Mountain thrust to form the Limestone Cove duplex.  $T_3$  shows the initial development of the Limestone Cove duplex.  $T_4$ ,  $T_5$ , and  $T_6$  shows the emplacement of the Limestone Cove duplex and the associated folding of the overlying Buffalo Mountain and Holston Mountain sheets. During  $T_7$  the Pulaski sheet began to form. Movement of the Pulaski sheet ( $T_8$ ) combined with the emplacement of the duplex acted like a vise on the Holston Mountain and Buffalo Mountain sheets. This vise effect caused both sheets to become synclinally folded.  $T_0$  shows the original pre-thrust position of the thrust sheets and horse blocks.

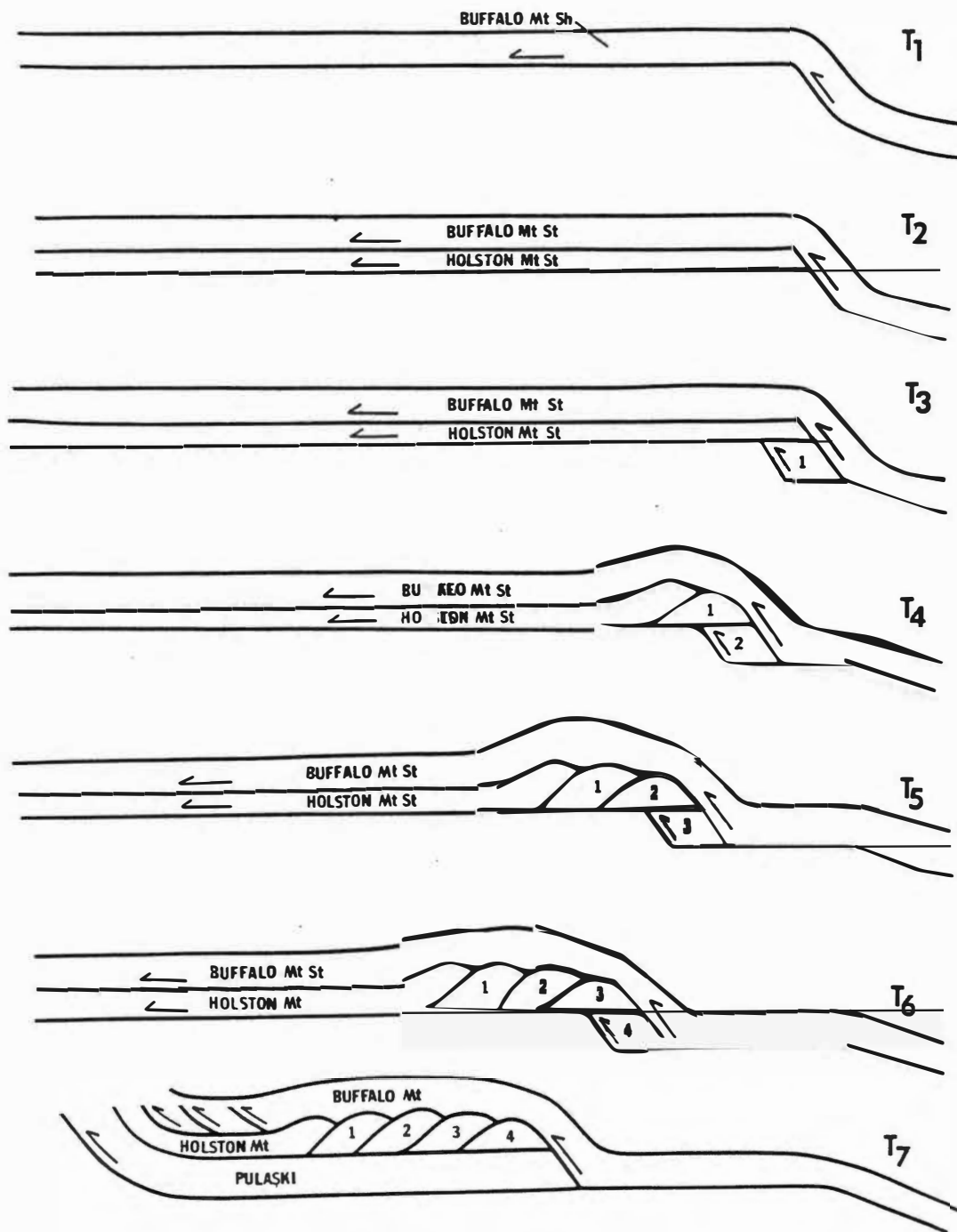

Figure 44.



determine the age sequence of imbrication by the distribution of stratigraphic throw or separation. Usually, in the distal or leading edge of a thrust sheet, most of the stratigraphic throw is on the lowest fault. This indicates that it is the oldest fault and that the faults within the imbricate zone have imbricated from lowest (foreland) to highest (hinterland) in a "break-back" fashion (see Figure 45). For the proximal or trailing edge Dahlstrom (1970) suggested that deformation is caused by the "bulldozer" action of the overlying thrust sheet. This "bulldozer" action produced a stack of imbricate thrusts that form in a hinterland to foreland sequence (see Figure 46).

Woodward, Boyer, and Suppe (1985) suggested that the deformation fabrics within the imbricate thrust pile will provide the critical evidence necessary to decipher the sequence of imbrication. If imbrication occurred from hinterland to foreland at depth in the trailing edge of a thrust sheet, then each imbricate sheet should show more penetrative fabrics than the next underlying imbricate sheet. If imbrication occurred from the foreland to the hinterland in the leading edge of a thrust sheet, then the hinterland, or back imbricates should show brittle deformation fabrics and the foreland, or front imbricates should show ductile deformation fabrics.

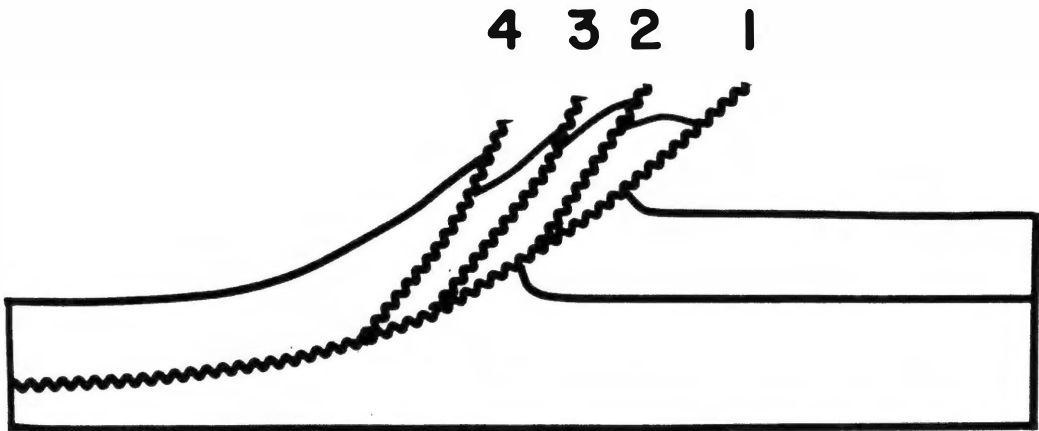

Figure 45. Sequence of imbrication at the leading edge of a thrust sheet; 1 = oldest, 4 = youngest. (from Dahlstrom, 1970).

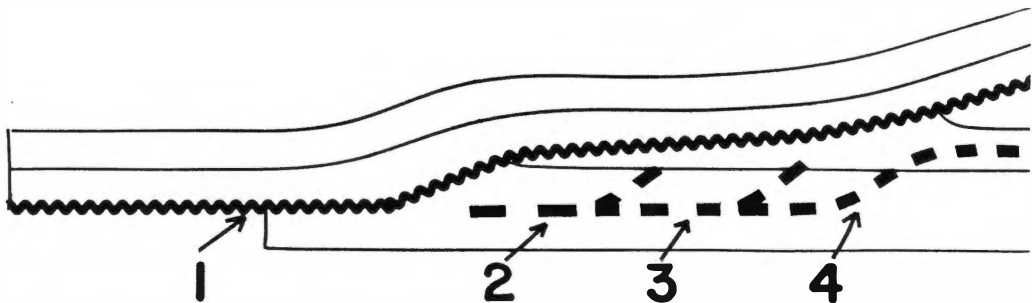

Figure 46. Sequence of imbrication at the trailing edge of a thrust sheet; 1 = oldest, 4 = youngest. (from Dahlstrom 1970).

Within the Buffalo Mountain area, Ordway (1949, 1959) proposed that during an advanced stage of thrusting, high frictional resistance along the Buffalo Mountain thrust caused the imbricate thrust network to develop. He did not feel that the arrangement of the imbricate sheets suggested an order to the imbrication. He concluded, rather, that imbrication could have occurred from the foreland to the hinterland or from the hinterland to the foreland.

Several features within the Buffalo Mountain area prompt me to reach a different conclusion concerning the sequence of imbrication within the Buffalo Mountain sheet. First, cataclastic fabrics are found just beneath both the Buffalo Mountain thrust (see Figures 27a, 27b, 27c, and 27d, page 74) and the more hinterland Pinnacle imbricate (see Figures 29a and 29b, page 82). Cataclastic fabrics are usually a result of brittle, or shallow deformation. Second, the deformational fabrics found in the hanging wall clastics are dominated by brittle features such as fractures and fractured grains (see Figures 26b and 26c, page 70, Figures 28a, 28b, 28c, and 28d, page 77). Mylonitic features are absent along the imbricates within the Buffalo Mountain sheet. Third, within the hanging wall of the Buffalo Mountain sheet at Indian Creek quartz grains are stretched into ribbons forming a mylonitic fabric (see Figures 29c and 29d, page 82). The mylonitic fabric is

found just above the Buffalo Mountain thrust and does not extend deeply into the sheet.

These features imply that the Buffalo Mountain thrust sheet was emplaced at a structurally shallow level. The presence of cataclastics along the imbricate thrusts indicates that the imbricate sheets were also emplaced at a shallow level, probably after the main sheet (Buffalo Mountain) was already emplaced. Although mylonitic fabrics are usually a result of deformation in a ductile regime, the mylonitic fabrics at Indian Creek probably did not form in a ductile regime. Instead, this fabric is probably a result of movement along the Buffalo Mountain thrust; as the sheet moved quartz grains were stretched or pulled into quartz ribbons. The quartz ribbons are present along the Buffalo Mountain thrust and not the hanging wall imbricates because the Buffalo Mountain thrust has traveled a much greater distance than the imbricates.

According to Dahlstrom (1970) the Buffalo Mountain sheet probably imbricated from the foreland to the hinterland in "break-back" fashion. Woodward, Boyer, and Suppe (1985) would suggest that the hinterland or back imbricates should show more brittle deformational fabrics than the foreland or front imbricates. Although Woodward, Boyer, and Suppe's (1985) argument concerning deformational fabrics and imbrication sequence is logical, it neglects to consider the scale, or size, of the thrust sheet in

question (Dahlstrom, 1970, p. 355). I feel that the Buffalo Mountain thrust sheet is simply too small to record a noticeable difference or contrast in deformational fabrics between imbricate sheets. Second, because a limited number of rock types are exposed in the field area, only a narrow range of deformation fabrics can be present. Such a narrow range of fabrics is probably not very sensitive to differences in stress across a thrust sheet.

A final feature related to the sequence of imbrication is that the Buffalo Mountain area is composed of a package of laterally overlapping or interleaved imbricate sheets. This observation is clear from both a general structure map (see Figure 11, page 40) and a branch line map (see Figure 12, page 42). This feature suggests to me that the imbricate thrusts at Buffalo Mountain formed simultaneously with one another. And because the imbricates are folded, they must have been emplaced before the folding of the Buffalo Mountain thrust sheet ceased.

These features lead me to conclude that internal imbrication of the Buffalo Mountain sheet occurred after or towards the end of thrust sheet emplacement, that the imbricates all formed at approximately the same time, and that the imbricates probably formed during or just before the end of thrust sheet folding. Thus, I propose that during the folding of the Buffalo Mountain thrust sheet (see Figure 44, T<sub>8</sub>, page 119) room problems within the core

of the sheet resulted in the formation of a series of overlapping imbricate faults. These imbricates emptied the core of extra rock and allowed continued folding.

## CHAPTER VIII

### CONCLUSIONS

From the examination of the structural geometries and deformational fabrics found in the Buffalo Mountain and northeast Tennessee area, several conclusions are drawn.

1. Plate 1 shows a geologic cross-section of the Buffalo Mountain area through the Ultrapinnacle, Pinnacle, and Intermediate sheets. In the cross-section, all thrust faults cut up stratigraphic section, and place older rocks over younger rocks. No thrusts cross-cut or displace other thrusts. The Intermediate sheet is homoclinally folded, the Pinnacle and Ultrapinnacle sheets are concentric in shape.

2. Canah Holow is interpreted as a foreland dipping duplex with a small "klippe" of Unicoi emplaced either by a pair of late extensional and contractional faults, erosional collapse, or mass wasting.

3. Thrust sheet emplacement occurred during a single stage or episode of deformation in a hinterland to foreland fashion. The structurally lower more foreland sheets, such as the horses of the Limestone Cove duplex and Pulaski sheet, folded the higher more hinterland Buffalo Mountain and Holstone Mountain sheets.

4. Folding of the Buffalo Mountain sheet is due to the vise-like or buttressing effect caused by the emplacement of the Limestone Cove duplex and Pulaski sheet.

5. The imbricates within the Buffalo Mountain sheet (Cherokee, Intermediate, Pinnacle, and Ultrapinnacle) all formed at approximately the same time, probably just before the end of thrust sheet folding. Furthermore, the imbricates formed in an attempt to remove rock from the core of the closing Buffalo Mountain sheet.

6. The mesoscopic and microscopic deformational features in the hanging wall clastics are characterized by quartz-filled fractures, fractured grains, pressure solution traces, undulatory extinction, slickensided bedding surfaces, and, along the Buffalo Mountain thrust, a mylonitic fabric.

7. The mesoscopic and microscopic deformational features in the foot wall carbonates are characterized by a cataclastic fabric (crushed, cracked, and fractured grains) that lacks internal foliation. Stylolitic pressure solution traces, and mineral-filled conjugate en echelon fractures are also present.

A developmental interpretation of the Buffalo Mountain area is as follows (see Figure 44, page 119): During  $T_1$  the Buffalo Mountain thrust sheet was emplaced. During the emplacement of the Buffalo Mountain sheet the Shady and Unicoi horses, which eventually became part of Canah Hollow



were formed. During T<sub>2</sub> the Holston Mountain sheet formed and was emplaced beneath the Buffalo Mountain sheet. Movement of the Buffalo Mountain/Holston Mountain thrust pile caused a set of imbricates to cut upward and join the Holston Mountain thrust to form the Limestone Cove duplex. T<sub>3</sub> shows the initial development of the duplex. T<sub>4</sub>, T<sub>5</sub>, and T<sub>6</sub> shows the emplacement of the Limestone Cove duplex and the associated folding of the overlying Buffalo Mountain and Holston Mountain sheets. During T<sub>7</sub> the Pulaski sheet began to form. Movement of the Pulaski sheet (T<sub>8</sub>) combined with the emplacement of the duplex acted like a vise on the Holston Mountain and Buffalo Mountain sheets. This vise or buttressing effect caused both sheets to become synclinally folded. During T<sub>8</sub> room problems within the core of the sheet resulted in the formation of a series of overlapping imbricate faults. These imbricates emptied the core of extra rock and allowed continued folding.

Thus, the Buffalo Mountain area provides a group of structurally complex features that have formed during a single progressive episode of hinterland to foreland thrusting.

## LIST OF REFERENCES

## LIST OF REFERENCES

- Badgley, P. C., 1959, Structural methods for the exploration geologist, New York, Harper and Brothers, 280p.
- Bally, A. W., Gordy, P. L., and Stewart, G. A., 1966, Structure, seismic data and orogenic evolution of southern Canadian Rockies: Bull. Can. Pet. Geol., v. 14, p. 337-381.
- Barrell, J., 1925, The nature and environment of the Lower Cambrian sediments of the southern Appalachians: Am. Jour. Sci., 5th ser., v. 9, p. 1-20.
- Bearce, D. N., 1966, Geology of the southwestern Bald Mountains in the Blue Ridge province of Tennessee: Unpublished Ph. D. dissertation, University of Tennessee. 147p.
- \_\_\_\_\_, 1969, Geology of the southwestern Bald Mountains in the Blue Ridge province of Tennessee: Southeastern Geology, v. 11, p. 21-36.
- Borradaile, G. J., Bayly, M. B., and Powell, C. McA., eds., 1982, Atlas of deformational and metamorphic rock fabrics: New York, Springer-Verlag, 551p.
- Boyer, S. E., 1978, Structure and origin of Grandfather Mountain window, North Carolina: Unpublished Ph. D. dissertation, Johns Hopkins University.
- Boyer, S. E., and Elliott, D., 1982, Thrust systems: Bull. Am. Assoc. Pet. Geol., v. 66, p. 1196-1230.
- Bryant, B., and Reed, J. C., 1970, Geology of the Grandfather Mountain window and vicinity, North Carolina and Tennessee: U. S. Geol. Sur. Prof. Paper, no. 615, 190p.
- Butler, R. W. H., 1982, The terminology of structures in thrust belts: J. Structural Geol., v. 4, p. 239-245.
- Butts, C., 1940, Geology of the Appalachian Valley in Virginia: Virginia Geol. Sur. Bull. 52, 568p.
- Campbell, M. R., 1897, Description of the Tazewell quadrangle: U. S. Geol. Sur. Atlas, Folio 59.

- Cloos, E., 1961, Bedding slips, wedges and folding in layered sequences: *Finlande Comm. Geol.* 196, p. 105-122.
- Cudzil, M. R., 1985, Fluvial, tidal and storm sedimentation in the Chilhowee Group (Lower Cambrian), northeastern Tennessee: Unpublished M. S. thesis. University of Tennessee. 164p.
- Currier, L. W., 1935, Zinc and lead region of southwestern Virginia: *Va. Geol. Sur. Bull.* 43, 122p.
- Dahlstrom, C. D. A., 1969, Balanced cross sections: *Can. Jour. Earth Sci.*, v. 6, p. 743-757.
- \_\_\_\_\_, 1970, Structural geology in the eastern margin of the Canadian Rocky Mountains: *Bull. Can. Pet. Geol.*, v. 18, p. 332-406.
- Dennis, J. G., 1981, What is a thrust? What is a Nappe?, in McClay, K. R., and Price, N. J., eds., *Thrust and Nappe Tectonics: Geol. Soc. London Special Publication No. 9*, p 449-462.
- Diegel, F. A., (in press, a), Topological constraints on imbricate thrust networks, examples from the Mountain City window, Tennessee.
- \_\_\_\_\_, (in press, b), Styles of imbricate thrusting in the Mountain City window area, Tennessee determined from patterns of branch lines and small scale structures.
- Diegel, F. A., and Wojtal, S. F., 1985, Structural transect in southwest Virginia and northeast Tennessee: *Univ. of Tenn. Dept. of Geol. Sci. Studies in Geology* 16, p. 70-143.
- Douglas, R. J. W., 1950, Callum Creek, Langford Creek and Gap Map areas, Alberta: *Geol. Survey Can. Mem.* 255, 124p.
- \_\_\_\_\_, 1958, Mount Head map area: *Geol. Survey Can. Mem.* 291, 241p.
- Elliott, D., 1976, The energy balance and deformation mechanisms of thrust sheet: *Phil. Trans. R. Soc. Lond. A*, 283, p. 289-312.

- \_\_\_\_\_, 1977, Some aspects of the geometry and mechanics of thrust belts. Parts 1 and 2. 8<sup>th</sup> Annual Seminar Can. Soc. Petrol. Geol., Univ. Calgary.
- \_\_\_\_\_, 1983, The construction of balanced cross-sections: J. Structural Geol., v. 5, p. 101.
- Elliott, D., and Johnson, M. R. W., 1980, Structural evolution in the northern part of the Moine thrust zone: Trans. Royal Soc. Edinburgh, Earth Sciences, v. 71, p. 69-96.
- Fox, F. G., 1969, Some principles governing interpretation of structure in the Rocky Mountain orogenic belt: in Kent, P. E. et al. eds, Time and Place in Orogeny: Geol. Soc. London Special Publication No. 3, 23-42.
- Ferguson, H. W., and Jewell, W. B., 1951, Geology and barite deposits of the Del Rio District, Cocke County, Tennessee: Tennessee Div. Geol. Bull. 57, 228 p.
- Gilluly, J., 1960, A folded thrust in Nevada--inferences as to time relations between folding and faulting: Am. Jour. Sci., v. 258-A, p.68-79.
- Gilluly, J., and Gates, O., 1965, Tectonic and igneous geology of the northern Shoshone Range, Nevada: U. S. Geol. Surv. Prof. Paper 465.
- Gwinn, V. E., 1964, Thin-skinned tectonics in the Plateau and Valley and Ridge Provinces of the central Appalachians: Geol. Soc. Am. Bull., v. 75, p. 863-900.
- \_\_\_\_\_, 1970, Kinematic patterns of lateral shortening, Valley and Ridge Province, Central Appalachians, south-central Pennsylvania: in Fisher, G. W., et al., eds., Studies of Appalachian Geology-Central and Southern: New York, Interscience Publishers, p. 161-173.
- Goddard, E. N., Trask, P. D., De Ford, R. K., Rove, O. N., Singewald, J. T., and Overbeck, R. M., 1980, Rock color chart: Geological Society of America.
- Hardeman, W. D., Swingle, G. D., and Miller, R. A., eds., 1966, Geologic map of Tennessee: Tenn. Div. Geol., Nashville, Tennessee., 1:250,000.

- Hadley, J. B., and Nelson, A. E., 1971, Geologic map of the Knoxville quadrangle, North Carolina, Tennessee, and South Carolina: U. S. Geol. Survey Misc. Geol. Inv. Map I-654, 1:250,000.
- Hamilton, Warren, 1961, Geology of the Richardson Cove and Jones Cove quadrangles, Tennessee: U. S. Geol. Sur. Prof. Paper 349-A, 55p.
- Harris, L. D., 1979, Similarities between the thick-skinned Blue Ridge anticlinorium and the thin-skinned Powell Valley anticline: Geol. Soc. Am. Bull., v. 90, p. 525-539.
- Harris, L. D., and Milici, R., 1977, Characteristics of thin-skinned style of deformation in the southern Appalachians and potential hydrocarbon traps: U. S. Geol. Sur. Prof. Paper 1018, 40p.
- Hatcher, R. D., Jr., 1978, Tectonics of the western Piedmont and Blue Ridge, Southern Appalachians; review and speculation: Am. J. Sci., v. 278, no. 3, p. 276-304.
- Hayes, C. W., 1891, The overthrust faults of the southern Appalachians: Geol. Soc. Am. Bull., v. 2, p. 141-154.
- Hobbs, B. E., Means, W. D., and Williams, P. F., 1976, An outline of structural geology: New York, John Wiley and Sons, Inc., 571p.
- Jarvis, R. P., 1912, The valley and mountain iron ores of east Tennessee: Resources of Tennessee, v. 2, p. 326-366.
- Jenkins, O. P., 1916, Phosphates and dolomites of Johnson County, Tennessee: Resources of Tennessee, v. 6, p. 51-106.
- Jones, P. B., 1971, Folded faults and sequences of thrusting in Alberta foothills: Amer. Assoc. Pet. Geol. Bull., v. 55, p. 292-306.
- Jonas, A. I., and Stose, G. W., 1939, Age relation of the Precambrian rocks in the Catoctin-Blue Ridge and Mount Rodgers anticlinoria in Virginia: Am. Jour. Sci., v. 237, p. 575-593.
- Keith, Arthur, 1899, Description of the Bristol quadrangle: U. S. Geol. Sur., Geol. Atlas Folio 59.

- \_\_\_\_\_, 1902, Folded faults in the southern Appalachians [Abstr.]: Science, New Ser., v. 15, p. 822-823.
- \_\_\_\_\_, 1903, Description of the Cranberry quadrangle: U. S. Geol. Sur., Geol. Atlas Folio 90.
- \_\_\_\_\_, 1907, Description of the Roan Mountain quadrangle: U. S. Geol. Sur., Geol. Atlas Folio 151.
- Kellberg, J. M., and Grant, L. F., 1956, Coarse conglomerates of the Middle Ordovician in the southern Appalachian Valley: Geol. Soc. Am. Bull., v. 67, p. 697-716.
- Keller, F. B., 1977, Polyphase folding and thrusting along the western margin of the Blue Ridge, Tennessee-North Carolina [Abst.]: Geol. Soc. Am., Abstr. Prog., v.9, No. 2 (Southeastern section, 26th annual meeting), p. 152-153.
- \_\_\_\_\_, 1980, Late Precambrian stratigraphy, depositional history, and structural chronology of part of the Tennessee Blue Ridge: Unpublished Ph. D. dissertation, Yale University. 363p.
- King, P. B., 1964, Geology of the central Great Smoky Mountains, Tennessee: U. S. Geol. Sur. Prof. Paper 349-C, 148 p.
- King, P. B., and Ferguson, H. W., 1960, Geology of northeast Tennessee: U. S. Geol. Surv. Prof. Paper 311, 136 p.
- King, P. B., Ferguson, H. W., Craig, L. C., and Rodgers, John, 1944, Geology and manganese deposits of northeastern Tennessee: Tenn. Div. Geol. Bull. 52, 275 p.
- Laurence, R. A., 1939, A small fenster in Johnson County, Tennessee: Tennessee Acad. Sci. Jour., v. 14, p. 200-202.
- Lowry, E. J., 1951, The southwest end of the Mountain City window, northeastern Tennessee: Unpublished Ph. D. dissertation, Yale University. 147p.
- Mackin, J. H., 1950, The down-structure method of viewing geological maps: Jour. Geol., v. 58, p. 55-72.

- Means, W. D., 1982, Crenulation cleavage in Martinsburg Slate, Delaware Water Gap Section, New Jersey, U. S. A., in Borradaile et al., eds., Atlas of deformational and metamorphic rock fabrics: New York, Springer-Verlag, p. 90-91.
- Milici, R. C., 1975, Structural patterns in the southern Appalachians: Evidence for a gravity slide mechanism for Alleghenian deformation: Geol. Soc. Am. Bull., v. 86, p. 1316-1320.
- Ordway, R. J., 1949, Geology and structure of the Buffalo Mountain-Cherokee Mountain area in northeastern Tennessee: Unpublished Ph. D. dissertation, Yale University. 90p.
- \_\_\_\_\_, 1959, Geology of the Buffalo Mountain-Cherokee Mountain area, northeastern Tennessee: Geol. Soc. Am. Bull., v. 70, p. 619-635.
- Oriel, S. S., 1950, Geology and mineral resources of the Hot Springs window, Madison County, North Carolina: N. C. Div. Min. Res. Bull. 60, 70p.
- Perry, W. J., Roeder, D. H., and Lageson, D. R., eds., 1984, North American thrust-faulted terranes: Tulsa, Oklahoma, The American Association of Petroleum Geologists, 466p.
- Price, R. A., 1967, The tectonic significance of mesoscopic subfabrics in the Southern Rocky Mountains of Alberta and British Columbia: Can. J. Earth Sci., v. 4, p. 39-70.
- \_\_\_\_\_, 1981, The Cordilleran foreland thrust and fold belt in the southern Canadian Rocky Mountains, in McClay, K. R. and Price, N. J., eds., Thrust and Nappe Tectonics: Geol. Soc. London Special Publication No. 9, p. 427-448.
- Purdue, A. H., 1914, Bauxite in Tennessee: Resources of Tennessee, v. 4, p. 87-92.
- Reed, J. C., 1970, The Blue Ridge and Reading Prong, Introduction: in Fisher, G. W., et. al., eds., Studies of Appalachian Geology--Central and Southern: New York, Interscience Publishers, p. 195.
- Resser, C. E., 1938, Cambrian system (restricted) of the southern Appalachians: Geol. Soc. Am. Spec. Paper 15, 140p.



- Rich, J. L., 1934, Mechanics of low angle overthrust faulting as illustrated by Cumberland thrust block, Virginia, Kentucky, and Tennessee: Am. Assoc. Pet. Geol. Bull., v. 18, p. 1584-1596.
- Rodgers, John, 1948, Geology and mineral deposits of Bumpass Cove, Unicoi and Washington Counties, Tennessee: Tenn. Div. Geol. Bull. 54, 78p.
- \_\_\_\_\_, 1953, Geologic map of East Tennessee with explanatory text: Tenn. Div. Geol. Bull. 58, 158p.
- \_\_\_\_\_, 1970, The Tectonics of the Appalachians: New York, Interscience Publishers, 271p.
- Roeder, D., Yust, W. W., and Little, R. L., 1978a, Folding in the Valley and Ridge province of Tennessee: Am. Jour. Sci., v. 278, p. 477-496.
- Roeder, D., Gilbert, O. E., and Witherspoon, W. D., 1978b, Evolution and macroscopic structure of Valley and Ridge thrust Belt, Tennessee and Virginia: Univ. of Tenn. Dept. of Geol. Sci. Studies in Geology 2, 25p.
- Royse, F., Jr., Warner, M. A., and Reese, D. L., 1975, Thrust belt structural geometry and related stratigraphic problems, Wyoming-Idaho-Northern Utah, in Bolyard, D. W., ed., Deep drilling frontiers of the central Rocky Mountains: Rocky Mtn. Assoc. Geologists, p. 41-54.
- Safford, J. M., 1856, A geological reconnaissance of the State of Tennessee: Tennessee Geol. Survey, 1st Bienn. Rept., 164p.
- \_\_\_\_\_, 1869, Geology of Tennessee: Nashville Tenn., 550p.
- Sander, B., 1921, Zur Geologie der Zentralalpen: Geol. Staatsanst: Wien Jahrb. 6, v. 71, p. 171-224.
- Schwab, F. L., 1972, The Chilhowee Group and the late Precambrian-early Paleozoic sedimentary framework in the central and southern Appalachians, in Lessing, P., et al, eds., Appalachian structures; origin, evolution, and possible potential for new exploration frontiers: Morgantown, West Virginia University and West Virginia Geological and Economic Survey, p. 59-101.

- Shackleton, R. M., 1958, Downwards-facing structures of the Highland border: Geol. Soc. London Quart. Jour., v. 113, p. 361-392.
- Shekarchi, E., 1959, The geology of the Flag Pond quadrangle, Tennessee-North Carolina: Unpublished Ph. D. dissertation, The University of Tennessee. 140p.
- Stose, G. W., and Schrader, F. C., 1923, Manganese deposits of east Tennessee: U. S. Geol. Surv. Bull. 757, 154p.
- Stose, G. W., and Stose, A. J., 1944, The Chilhowee Group and Ocoee Series of the southern Appalachians: Am. Jour. Sci., v. 242, p. 367-390, 401-416.
- Suppe, J., 1983, Geometry and kinematics of fault-bend folding: Am. Jour. Sci., v. 283, p. 684-721.
- Thompson, R. I., 1981, The nature and significance of large "blind" thrusts within the northern Rocky Mountains of Canada, in McClay, K. R., and Price, N. J., eds., Thrust and Nappe Tectonics: Geol. Soc. London Special Publication No. 9, p. 449-462.
- Verrall, P., 1968, Observations on geological structure between the Bow and North Saskatchewan rivers: Alberta Soc. Pet. Geologists 16th Ann. Field Conf. Guidebook, p. 106-118.
- Walcott, C. D., 1891, Correlation papers: Cambrian: U. S. Geol. Surv. Bull., 81, 447p.
- Willis, B., 1891, The mechanics of Appalachian structure: U. S. Geol. Surv. 13th Ann. Rept., p. 217-281.
- Woodward, N. B., (1986), Fault geometries and tectonic reconstructions of the Tennessee Blue Ridge [Abst.]: Geol. Soc. Am., Abstr. Prog., v. 18.
- Woodward, N. B. ed., 1985, Valley and Ridge thrust belt: balanced structural sections, Pennsylvania to Alabama: Appalachian Basin Industrial Association, Univ. of Tenn. Dept. of Geol. Sci. Studies in Geology 12, 64p.
- Woodward, N. B., Boyer, S., and Suppe, J., 1985, An outline of balanced cross-sections, notes for a short course: Univ. of Tenn. Dept. of Geol. Sci. Studies in Geology 11, 2nd ed., 123p.

Wilson, C. J. L., 1982, Foliation in quartz mylonite, in Borradaile et al., eds., Atlas of deformational and metamorphic rock fabrics: New York, Springer-Verlag, p. 340-341.

## APPENDIX

## APPENDIX A

### ROAD LOG AND DESCRIPTION OF STOPS

MILEAGE		DESCRIPTION
Cumulative	Interval	
0.0	0.0	Depart from Geology and Geography building on "The Hill". Turn left on Cumberland. Turn right on 17 <sup>th</sup> . Take I-40 E 81 N toward Ashville.
33.2	33.2	I-40 E separates from I-81 N. Stay on I-81 N toward Bristol.
54.9	21.7	Exit 23 to Greenville, Bulls Gap. Leave interstate. Stop. Turn right (east) to Greenville. Proceed on U.S. 11 E North (Robert F. Smith Parkway).
66.5	10.7	U.S. 11 E North splits. Take left U.S. 11 E North fork to Jonesboro, Johnson City (John S. Rhea Parkway).
70.4	4.8	Turn right (east) on TN 107 E. The lower mountains in the distance are part of the Buffalo Mountain thrust sheet (Sampson Mountain), the higher mountains in the background are part of the Unaka belt.
90.6	20.2	Turn right (south) on TN 81 S/107 E. At the intersection, Embreeville Mountain is on the right, Cherokee Knob is straight ahead, and Buffalo Mountain is between the two.
91.4	0.8	Turn left onto gravel road. Stop 1.

Exposure of the Buffalo Mountain thrust. The thrust places upper Unicoi clastics over Knox carbonates (contact can be recognized due to the change in vegetation) Figure 14, page 47. The hanging wall Unicoi (Intermediate sheet) strata strikes north 50° east and dips 50° southeast. The foot wall Knox is complexly folded into an anticline-syncline pair. The anticline is a broad, open, asymmetrical fold northwest of the syncline. The syncline,

located directly beneath the thrust, is a tight, overturned to the northwest, similar fold. The overturned upper limb is parallel or nearly parallel to the Buffalo Mountain thrust. Continue south along TN 81 S/107 E.

MILEAGE		DESCRIPTION
Cumulative	Interval	
92.4	1.0	View of antithetic thrust and associated hanging wall anticline in the resistant unit of Hampton in the Intermediate sheet (see Figure 15, page 47).
92.8	0.4	Cross Nolichucky River.
93.0	0.2	Turn left (north) just past bridge onto TN 106 (paved road). Outcrop of Hampton on corner.
93.2	0.2	Pull over on left shoulder. Cross road and go up hill 10 meters (30 feet) to ledge. Stop 2.

Hampton sandstones are folded into an anticline. The fold is concentric and open. The axis of the fold trends north 65° east with no plunge (see Figure 28a, page 77). Continue north along TN 106.

MILEAGE		DESCRIPTION
Cumulative	Interval	
93.8	0.6	Outcrop of thick quartzite unit; base of Erwin Formation.
93.9	0.1	Outcrop of thick quartzite unit; base of Erwin Formation. Quartzite unit repeated by local tear fault.
94.5	0.6	Pull off at Knox outcrop on right. Stop 3.

At the extreme northern end of the outcrop the Knox is folded into a small open syncline. The northwestern limb of the syncline strikes north 70° east and dips 15° south. The southeastern limb strikes north 75° east and dips 20° north. The hinge line of the syncline trends north 75° east and plunges 0°; the axial plane strikes north 75° east and dips 80° south (see Figure 22, page 63). 60 meters south of the syncline the Knox arches over forming a broad, concentric anticline that is slightly overturned to the

southeast. The northwestern limb of the anticline strikes north  $75^{\circ}$  east and dips  $20^{\circ}$  north. The southeastern limb strikes north  $75^{\circ}$  east and dips  $20^{\circ}$  south. The hinge line of the anticline trends north  $75^{\circ}$  east and plunges  $0^{\circ}$ ; the axial plane strikes north  $75^{\circ}$  east and dips  $75^{\circ}$  northwest (see Figure 22, page 63). Immediately south of this anticline, the Knox is sharply folded back into a tight similar syncline that is overturned to the northwest. The northwestern limb of the syncline strikes north  $70^{\circ}$  east and dips  $45^{\circ}$  south. The southeastern limb is overturned (stratigraphic up is to the north) and strikes north  $80^{\circ}$  east and dips  $75^{\circ}$  south. The hinge line of the fold trends north  $85^{\circ}$  east and plunges  $15^{\circ}$  south; the axial plane strikes north  $85^{\circ}$  east and dips  $40^{\circ}$  southeast (see Figure 22, page 63). The southeastern limb of the syncline remains overturned for a distance of 200 meters (600 feet) until it meets the upper Unicoi rocks of the Buffalo Mountain thrust sheet. Dip gradually decreases from  $75^{\circ}$  south near the syncline to  $45^{\circ}$  south just beneath the Buffalo Mountain thrust.

Around the northwestern limb of the small syncline at the north end of the exposure, parallel fibrous growths of calcite or slickensides trend south  $20^{\circ}$  east on the tops of bedding surfaces (see Figure 22, page 63). On the southeast limb of the syncline several minor contractional faults with less than .5 meters (18 inches) displacement cut through the Knox. The faults strike north  $70^{\circ}$  east and dip both to the north and south approximately  $60^{\circ}$  (see Figure 22, page 63). Several thick spary calcite filled veins are located near the crest of the broad anticline. The veins are linear in shape, strike north  $75^{\circ}$  east and dip vertically (see Figure 22, page 63).

The overturned syncline at the southern end of the outcrop contains a strong pressure solution cleavage within its core (see Figure 22, page 63). Hand sample (see Figure 23a, page 65) study indicates that the cleavage ( $S_1$  in Figure 23a, page 65) is spaced (2 to 3 centimeters; 1 inch), stylolitic to smooth in shape with a parallel pattern. The cleavage is slightly convergent with respect to the axial fold plane. Also within the syncline core are a series of calcite filled en echelon conjugate fractures. The veins are generally a couple of centimeters long (1 or 2 inches), 1 centimeters thick (0.4 inches), and planar to slightly sigmoidal in shape. The en echelon sets are divergent to the core of the fold. One set of the conjugate fractures strikes north  $15^{\circ}$  west and dips  $60^{\circ}$  northwest, the other set is horizontal (see Figure 22, page 63).

Along the southeastern limb of the syncline, near the core, several thin calcite veins trend sub-perpendicular to the axial plane (see Figure 23b, page 65). The veins ( $S_2$

in Figure 23b, page 65) are several meters long, strike north 10° west and dip 25° east (see Figure 22, page 63). The calcite within the veins is highly twinned. A stylolitic pressure solution cleavage ( $S_1$  in Fig. 23b, page 65) is also present. The cleavage is spaced (0.5 to 1.0 centimeters; 1 to 2 inches) and is sub-parallel to the axial plane and to bedding ( $S_0$  in Figure 23b, page 65). In thin-section the cleavage both cross-cuts and is cross-cut by the calcite veins. Also, examination of the stylolites reveals that many of the cleavages are surrounded by envelopes of calcite veins (see Figure 23c, page 65). This feature suggests a complicated history of compression followed by extension for the rock beneath the Buffalo Mountain thrust. Moving south, away from the syncline, the overturned beds contain many interlayer contractional faults, or bedding wedges. The faults generally produce several meters of displacement and intersect bedding at about 30° (see Figure 22, page 63).

MILEAGE		DESCRIPTION
Cumulative	Interval	
94.9	0.4	Intersect TN 106. Turn right (northeast). Cherokee Knob is in the foreground. Outcrops of subverticle Knox.
96.0	1.1	Pull off at outcrop of Buffalo Mountain thrust. Stop 4.

The fault strikes north 75° east, dips 50° southeast and places upper Unicoi clastics over Knox carbonates (see Figure 26a, page 70). The Unicoi strikes north 75° east, dips 50° to the south and contains a well developed, closely spaced, planar cleavage. The cleavage is parallel to the thrust plane and dies out a few meters above the fault. Above the cleavage zone the Unicoi shows few deformational features except for bedding-perpendicular jointing and a strong green coloration. Handsamples of the Unicoi (see Figure 26b, page 70) do not display a mylonitic texture and the grains do not appear to possess a preferred orientation. Fractures ( $S_2$  in Figure 26b, page 70), spaced about 0.5 centimeters (1 inch) apart, are oriented approximately perpendicular to the fault plane; the material within the fracture has weathered out. A cleavage ( $S_1$  in Figure 26b, page 70), visible as thin wispy dark planar traces, is also present. The cleavage is spaced (25 millimeters; 0.1 inches) and is oriented sub-parallel to the fault. In thin-section the cleavage ( $S_1$  in Figure 26c, page 70) usually appears as a smooth to anastomosing incipient foliation (see Figure 26c, page 70), or as a



planar discrete bundle-like foliation. The cleavage is composed of an insoluble reddish-brown material. The quartz grains display undulatory extinction and are highly fractured (fractures are easily visible at magnifications of 10x and above). The average size of a quartz fragment is about .01 millimeter in diameter (see Figure 26c, page 70); all of the fragments of a single grain are optically continuous.

The foot wall Knox is overturned, strikes north 75° east, dips 60° to the south, and contains a well developed cataclastic fabric. Just beneath the fault surface an ultracataclasite is present. The ultracataclasite (see Figure 27a, page 74) is about 25 millimeters (0.1 inches) thick, buff brown in color with no layering or banding present. In thin-section (see Figure 27b, page 74), individual grains are difficult to resolve. No internal foliation is present. Stylitic pressure solution traces parallel the fault plane and form the base of the ultracataclasite zone. In addition, late calcite veins and stylites cut the ultracataclasite. Beneath the ultracataclasite is a 1 to 2 centimeter (0.5 to 1 inch) thick protocataclasite (see Figure 27a, page 74). The protocataclasite is dark grey with no apparent stratification. In thin-section (see Figure 27b, page 74) the rock is composed of about 80% matrix and 20% quartz clasts. The matrix is very fine-grained with individual grains difficult to recognize. The clasts are generally 0.05 millimeters in diameter, equant, rhombohedral shaped fragments of quartz that do not exhibit undulatory extinction. The clasts do not possess a dimensional preferred orientation. The rock is cut by laterally continuous calcite-filled veins and stylites (see Figure 27b, page 74). The veins form 30° to 60° angles with the fault plane, and are composed of highly twined calcite (see Figure 27b, page 74). Beneath the protocataclasite is an orthocataclasite. Due to the lack of outcrop the thickness of the orthocataclasite is unknown. The rock is cut by thin calcite-filled fractures and late stylites (see Figure 27c, page 74). In thin-section (see Figure 27d, page 74) the orthocataclasite is composed of 85% calcite blocks and 15% vein filling calcite. The calcite veins form a complex intersecting pattern dividing the rock into 75 millimeter (0.3 inch) sized, subangular aggregates of microcrystalline calcite. Furthermore, the blocks possess no preferred orientation.

MILEAGE		DESCRIPTION
Cumulative	Interval	
97.9	1.9	Turn around and retrace to TN 81 S/107 E. Intersect TN 81 S/107 E.

Turn left (southeast) on to TN 81  
S/107 E.

- |      |     |   |
|------|-----|---|
| 99.7 | 1.8 | Enter Unicoi Co. Exposures on left and right (across Nolichucky River) are of a resistant unit of Hampton. The Hampton strikes north 40° east and dips from 30° to 10° southeast. |
| 99.7 | 0.0 | Pull over at turnoff on the right just past the Unicoi Co. line.  |
| 99.8 | 0.1 | Walk 0.1 miles southeast to the guardrail. Stop 5. Pinnacle imbricate thrust.   |

At road level lower Unicoi sandy shales are thrust over quartzites of the Hampton, up slope, the lower Unicoi is placed against the Erwin. The thrust strikes north 40° east and dips 50° southeast (see Figure 13, page 44). The hanging wall lower Unicoi strikes north 40° east and dips 25° southeast. Several minor folds within the lower Unicoi contain fold axes that trend north 40° east with zero plunge. The folds are concentric open folds. The foot wall Hampton strata strikes north 30° west and dips 65° southwest. Concentric open folds within the Hampton contain fold axes that trend north 45° east with zero plunge.

In hand sample neither the Unicoi or Hampton show a mylonitic fabric or a preferred orientation of quartz grains. Quartz-filled fractures within the Unicoi (see Figure 28b, page 77) are oriented sub-perpendicular to the fault plane. In thin-section the fractures are composed of fine-grained quartz material (see Figure 28c, page 77). The fractures do not seem to follow detrital quartz boundaries, but rather cut through the grains. Figure 28c, page 77, shows a fracture that has cut through and split a detrital grain into several fragments (note that the fragments of a single detrital quartz grain are optically continuous). Individual detrital quartz grains possess undulatory extinction and are highly fractured or crushed. The fragments are extremely angular and are about 0.01 millimeters (0.004 inches) in diameter; fragments within single grains are optically continuous.

MILEAGE		DESCRIPTION
Cumulative	Interval	
101.0	1.2	Turn left onto gravel road into Canah Hollow. Stop 6.

Structurally the area is composed of five complexly arranged units of rock (see Figure 17, page 54). The five units are: the southeastern edge of the Intermediate sheet; the southwestern end of the Pinnacle sheet; a unit of Shady located southeast and southwest of the Pinnacle sheet; a large mass of Unicoi positioned just southeast of the unit of Shady; and southeast of the mass of Unicoi, a section of the Holston Mountain thrust sheet (footwall of the Buffalo Mountain thrust).

The southwestern end of the Pinnacle sheet is in thrust contact with both the southeastern edge of the Intermediate sheet and the large unit of Shady. Both the Pinnacle sheet and the unit of Shady are folded into a northeast plunging anticline-syncline pair. Beds within the southeastern mass of Unicoi are not folded, but strike north 30° west and dip 70° northwest (see Plate 1). The mass of Unicoi dips northwest beneath the Shady and is underlain by the northwest dipping Holston Mountain thrust sheet. In addition, the mass of Unicoi is completely enveloped by thrust faults, and graded beds indicate that stratigraphic younging is to the northwest. A sixth unit of rock (see Figure 17, page 54), a minor slice of Unicoi, located on the ridge east of Canah Hollow, overlies and is folded along with the Shady.

Canah Hollow is interpreted as a foreland-dipping duplex. The section of Shady is a horse block wedged between the overlying Pinnacle sheet and the underlying horse of Unicoi. The floor thrust of the duplex merges with the roof thrust beneath the Pinnacle sheet, with the roof thrust continuing to cut up stratigraphic section as the Pinnacle imbricate (see Figure 34, page 98). Continue northeast along gravel road.

MILEAGE		DESCRIPTION
Cumulative	Interval	
101.6	0.6	Pull over at turnoff on right. Stop 7. Pinnacle imbricate.

At this location upper Unicoi clastics are placed over Shady Dolomite. The outcrop is poorly exposed with only the upper Unicoi beds cropping out in place. The upper Unicoi strata strikes north 55° east and dips 45° southeast. No folds are present, however, the Unicoi does contain 1 to 3 centimeter (2 to 6 inch) spaced joints that are perpendicular to bedding. In hand sample (see Figure 28d, page 77) the Unicoi does not have a mylonitic texture or a preferred orientation. Sets of conjugate fractures are present however. One set (S<sub>1</sub> in Figure 28d, page 77) is approximately parallel to the fault plane, the other set

(S<sub>2</sub> in Figure 28d, page 77) forms about a 30° angle with the fault plane. Several of the larger quartz grains are fractured or smashed. In thin-section the fractures are composed of fine-grained quartz material similar to the fractures already described in the Unicoi. The fractures seem to both follow detrital grain boundaries and to cut through and split detrital grains. Individual detrital quartz grains possess undulatory extinction and are highly fractured. The fragments are subangular in shape and are about 0.2 to 0.4 millimeters (0.03 inches) in diameter; the fragments of most detrital grains are not optically continuous.

The Shady is so poorly exposed that only float fragments are present. Examination of the float fragments in hand sample and in thin-section reveals a cataclastic fabric. In hand sample (see Figure 29a, page 82) the Shady is composed of subangular blue dolostone fragments set in a fine-grained grey to white matrix; several chalk white fractures cut the rock. No layering or preferred orientation of the grains is evident. In thin-section (see Figure 29b, page 82) the dolostone fragments are 0.4 millimeters (0.04 inches) in diameter, subangular to angular and are composed of highly fractured or twinned material. The matrix is very fine-grained and contains occasional rhombs of dolomite. The rock is composed of about 60% matrix and 40% fragments. Fractures filled with twinned calcite cut through both the matrix and the dolostone fragments. Also a weak foliation is present. The foliation is anastomosing to planar in shape and is composed of insoluble residue. The foliation is subparallel to many of the calcite fractures.

MILEAGE		DESCRIPTION
Cumulative	Interval	
102.2	0.6	Turn around and retrace to TN 81 S/107 E. Turn left (southeast) onto TN 81 S/107 E. Exposures of Shady on left.
103.1	0.9	Enter Erwin, TN "The Valley Beautiful". Intersect U.S. N 19 W 23 Bypass, continue straight into Erwin "The Valley Beautiful".
103.6	0.5	Intersect U.S. N 19 W 23. Turn left (northeast) on U.S. N 19 W 23. Good view of Buffalo Mountain on left. Iron Mountain fault is located in the hills to the right.

- 104.1        1.5    Intersect overpass to U.S. N 19 W 23 Bypass. Turn left (northwest) on to overpass.
- 104.3        0.2    Continue on overpass of U.S. N 19 W 23 Bypass. Intesect paved access road across overpass. Turn left (southwest) on to paved access road.
- 104.8        0.5    Pull over at the intersection of the gravel road on right (Ashhopper Hollow). Stop 8.

On the southeast side of the Ultrapinnacle sheet along Indian Creek, Ashhopper Hollow, Harris Hollow, and Whaley Brook (Pippen Hollow) two cleavages are present. The first cleavage is found within the gorge of the Indian Creek near Ashhopper Hollow. This cleavage is continuous, tightly spaced and parallel or planar in form. The cleavage strikes north  $45^{\circ}$  east and dips  $40^{\circ}$  northwest which is parallel to bedding and the underlying Buffalo Mountain thrust. In thin-section (see Figures 29c, 29d, page 82) this cleavage ( $S_1$  in Figures 29c, 29d, page 82) appears as a dark, continuous, closely spaced feature. The cleavage is smooth and planar in shape. Paralleling this cleavage are thin quartz ribbons (see Figure 29d, page 82). The ribbons are up to 0.4 millimeters (0.04 inches) in cross-sectional length. The presence of this fabric suggests a mylonitic foliation. The second cleavage is present both within the gorge of Indian Creek and up slope along Ashhopper Hollow, Harris Hollow and Whaley Brook (Pippen Hollow). Within the Indian Creek gorge the second cleavage ( $S_2$  in Figures 29c, 29d, page 82) crenulates the first bedding-thrust parallel cleavage. In thin-section (see Figures 29c, 29d, page 82) the crenulations clearly fold the thrust parallel cleavage and have also slightly rotated the associated quartz ribbons. The crenulation cleavage strikes north  $30^{\circ}$  to  $50^{\circ}$  east, dips  $45^{\circ}$  to  $50^{\circ}$  southeast and is spaced at about .25 centimeter (.5 inch) intervals. Within the up slope hollows the second cleavage ( $S_2$  in Figure 30a, page 86) forms as a spaced parallel cleavage containing smooth cleavage domains (see Figure 30a, page 86). The cleavage strikes northeast and dips  $35^{\circ}$  to  $65^{\circ}$  southeast and is oriented upwards facing with respect to bedding, (Shackelton, 1950; Diegel, in press, a and b). In thin-section (see Figure 30b, page 86) the cleavage ( $S_2$  in Figure 30b, page 86) is dark, continuous, closely spaced and has a smooth or planar shape. The cleavage is most common in the finer-grained layers and is often slightly refracted by the coarser-grained layers.

MILEAGE		DESCRIPTION
Cumulative	Interval	
103.3	0.5	Turn around (northeast) on to access road. Intersect overpass to U. S. N 19 W 23 Bypass.
105.5	0.2	Turn right (southeast) on to overpass of U. S. N 19 W 23 Bypass. Intesect N 19 W 23.
107.0	1.5	Turn right (southwest) on to U.S. N 19 W 23. Intersect TN 81 S/107 E.
113.9	6.9	Turn right (northwest) on to TN 81 S/107 E. Intersect TN 107 E.
134.1	20.2	Turn left (southwest) on to TN 107 E. Intersect U. S. 11 E.
149.8	15.7	Turn left (west) on to U. S. 11 E. Intersect I-81 S.
204.7	54.9	Turn left on to I-81 S to Knoxville, Tennessee. Return to "The Hill".

## VITA

Mark Morgan Duddy was born July 12, 1961 in Atlanta, Ga. He attended Hawthorn Elementary School and Lakeside High School. He graduated from Hendersonville High School, Hendersonville, Tennessee in 1979. In the Fall of 1979 he entered The University of Tennessee. He graduated with honors from The University of Tennessee in the Spring of 1983 with a Bachelor of Arts degree in Geology. In the Fall of 1983 he entered the graduate program in geological sciences at The University of Tennessee, where he received a Master of Science degree in Geology in June, 1986.

# GEOLOGIC MAP AND STRUCTURE SECTIONS OF BUFFALO MOUNTAIN, TENNESSEE

By  
Mark M. Duddy

1986

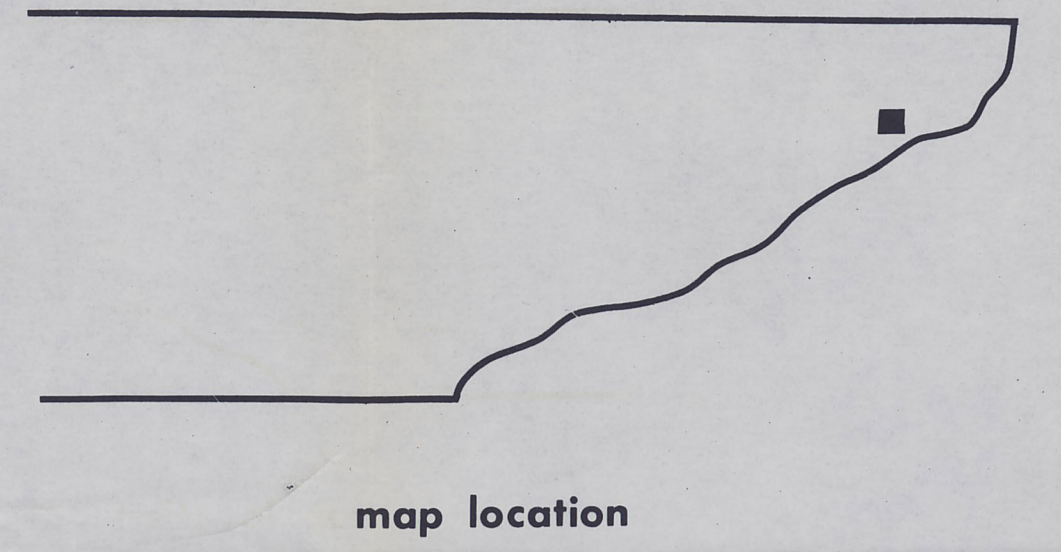
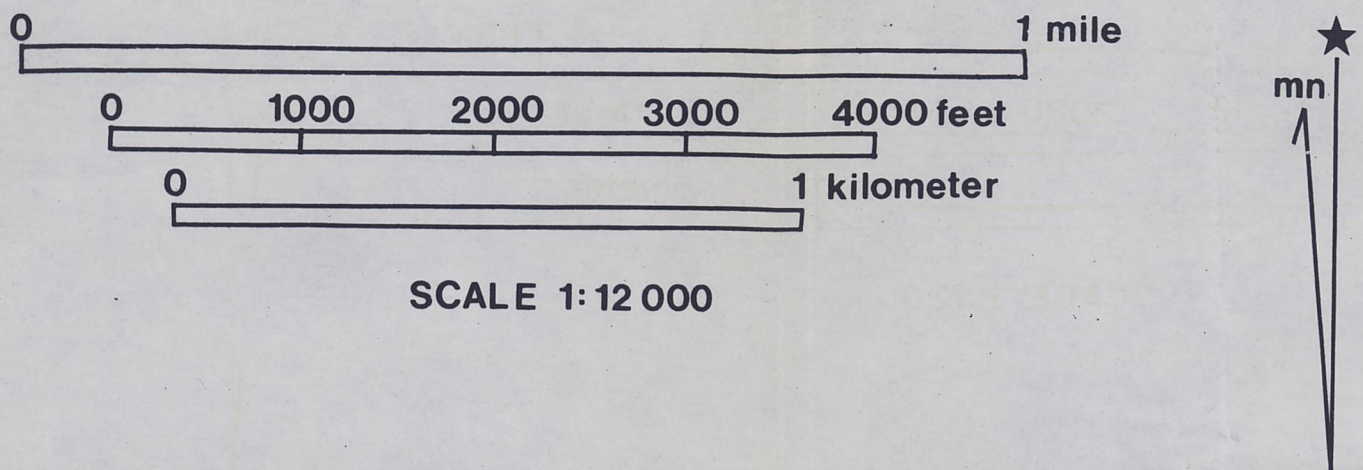

Plate I



**Map Units**

Ock	Knox
Cn	Nolichucky
Chk	Honaker
Cr	Rome
Cs	Shady
Ce	Erwin
Ch	Hampton
Cuu	upper Unicoi
Cu	Unicoi
Cul	lower Unicoi

**Map Symbols**

▲	Thrust Fault, dashed where approximate, dotted where very approximate
---	Contact, dashed where approximate, dotted where very approximate
45	Strike and Dip of Bedding
50	Overturned Bedding + Vertical Bedding
45	Strike and Dip of Cleavage
10+	Syncline
10+	Anticline

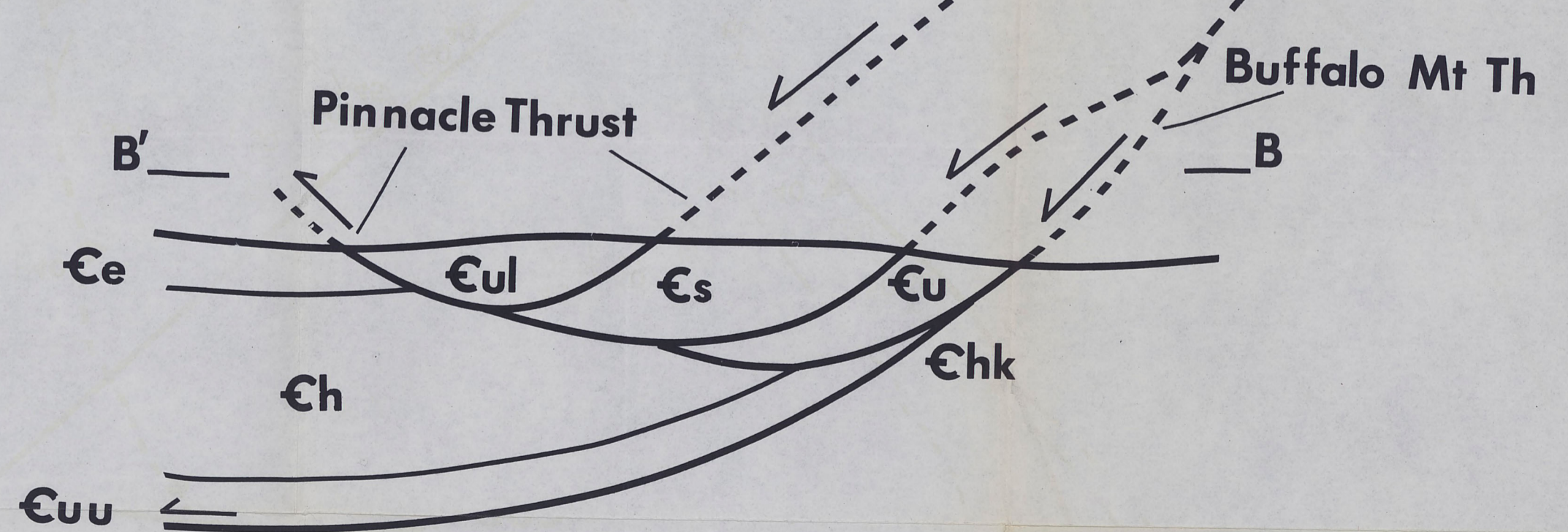

V.E.=0

