



University of Tennessee, Knoxville
Trace: Tennessee Research and Creative Exchange

University of Tennessee Honors Thesis Projects

University of Tennessee Honors Program

5-2016

A Study of HIV and Stigma at the University of Tennessee: A Discussion of its Prevalence and How HIV Awareness Correlates with Stigma

Renee L. Adamec

University of Tennessee, Knoxville, radamec@vols.utk.edu

Follow this and additional works at: https://trace.tennessee.edu/utk_chanhonoproj

 Part of the [Medicine and Health Commons](#), [Other Immunology and Infectious Disease Commons](#), and the [Social Psychology Commons](#)

Recommended Citation

Adamec, Renee L., "A Study of HIV and Stigma at the University of Tennessee: A Discussion of its Prevalence and How HIV Awareness Correlates with Stigma" (2016). *University of Tennessee Honors Thesis Projects*.
https://trace.tennessee.edu/utk_chanhonoproj/1961

This Dissertation/Thesis is brought to you for free and open access by the University of Tennessee Honors Program at Trace: Tennessee Research and Creative Exchange. It has been accepted for inclusion in University of Tennessee Honors Thesis Projects by an authorized administrator of Trace: Tennessee Research and Creative Exchange. For more information, please contact trace@utk.edu.

**A Study of HIV and Stigma at the University of Tennessee:
A Discussion of its Prevalence and
How HIV Awareness Correlates with Stigma**

*An Honors Thesis Submitted to
the Chancellor's Honors Program
in partial fulfillment of the Honors requirements*

UNIVERSITY OF TENNESSEE

**by
Renee Adamec
April 29th, 2016**

Table of Contents

- I. Abstract
- II. Introduction
- III. HIV Pathogenesis
- IV. HIV Treatments
- V. Current Prevalence of Stigma
- VI. A Survey at UT-Knoxville
- VII. Living with HIV
- VIII. Accessibility
- IX. Conclusions
- X. References
- XI. Supplement: HIV Awareness and Stigma Survey
- XII. Role in Project
- XIII. Acknowledgments

Abstract

The goal of this work was to investigate the sources of stigma not only from primary literature, but also using a survey conducted at the university of Tennessee-Knoxville. The survey also sought to correlate awareness of HIV progression, transmission, and treatment to level of stigma. Though there was no overall correlation, the survey did find that fear of transmission correlated significantly with overall stigma. The results of the survey aligned with other studies performed. The paper goes on to elucidate the way stigma affects people living with HIV and their access to medical care, and provides a current outlook on if and how society can create a more constructive environment for people living with HIV.

Introduction

Human immunodeficiency virus (HIV) has been a hot research topic since its debut in the 1980s. The retrovirus is excellent at what it does, which is attack the immune cells of its unfortunate host so that it can run rampant in the body. Though it has been a prevalent disease for over thirty years, the best way of treating HIV remains combined oral antiretroviral treatments, which seek to disable viral machinery in a multitude of ways. Current research on creating vaccines and cures has told us much about the disease itself, but has not yielded safe ways to eradicate the virus. The most common conclusion in HIV research is that the virus is more complicated than previously thought. Despite failed attempts at truly novel ways of treating HIV, improvements to familiar treatments have been made. But treating HIV is not the only challenge surrounding those afflicted. Ever since it reached the public eye, it has been one of the most stigmatized diseases of modern times.

To truly understand current social interaction with people living with HIV (PLHIV), we must also understand the history of how HIV came to the forefront as a stigmatized disease. It has been established that the virus was transferred to humans in the 1920s or earlier through a variant of simian immunodeficiency virus (SIV), most likely due to the consumption of monkey in the Kinshasa. By the 1960s, HIV had made its way to Haiti (Faria 2014). When hospitals in North America saw the first few cases of HIV in the 80s, they had no way of knowing what they were dealing with. They only knew it presented with Kaposi's sarcoma (KS) and abnormal lung infections, and that both were signs of an underlying immune problem. A host of papers published by the Centers for Disease Control and Prevention (CDC) in the early 80s showed ever increasing symptoms of immunodeficiency in homosexual men, intravenous drug users, and blood transfusion recipients. The disease took on many names, such as "gay cancer," "gay

compromise syndrome,” and today’s “acquired immunodeficiency syndrome”(Brennan 1981, Auerbach 1984, McKay 2014). A 1984 study in the American Journal of Medicine became the first of many mapping the spread of HIV based on KS and opportunistic infection in homosexual males, concluding that a certain “patient O” had been the source of HIV/AIDS transmission in New York, Los Angeles, and San Francisco, among others (Auerbach 1984). Patient zero, as it came to be called, was eventually uncovered as Gaetan Dugas, a homosexual Canadian flight attendant who was in prime position to carry a sexually transmitted virus from coast to coast (Shilts 1987). His symptoms began in 1980, and his continued sexual forays ensured transmission across the United States. According to journalist and novelist Randy Shilts, Dugas was intent on living a full life despite of his malaise, and despite the consistent warnings from his doctors. Two years after his death, his story was published as a part of Shilts’s interpretation of the HIV phenomenon, *And the Band Played On*. The “Patient Zero” story gained enough attention to be on *60 Minutes* and other news headlines, bolstering the American public’s understanding of Dugas and the gay community as the villains behind HIV/AIDS. However, Robert McKay opposes this depiction of Dugas in his 2009 article addressing the shortcomings of Shilts’s rendition. Shilts used edited interviews to present Dugas as a self-loathing character so filled with anger at himself and his condition that he intentionally infected other gay men. At the very least, Shilts writes, he was so recklessly intent on carrying out his lifestyle that the collateral damage was of little consequence. But, as McKay points out, the CDC only confirmed HIV/AIDS as a sexually transmitted virus in April of 1984, one month after Dugas’s death (Administration 2014, McKay 2014). Thus, some see Dugas as the antagonist of the HIV/AIDS saga, while others count him as an unfortunate victim of a novel virus whose story happened to

be the most publicized. Whatever the case, Randy Shilts's book was just part of the highly stigmatizing media coverage when HIV/AIDS first became a problem in North America.

Around the same time Dugas was showing his first symptoms of HIV, the new disease was reported to the CDC. However, it was three years before researchers understood the disease as a sexually-transmitted virus, and six before the first approved treatment was available.

Fortunately, the Food and Drug Administration (FDA) had established a faster protocol to get treatments approved, started testing blood and plasma stocks, was approving better ways of testing for HIV, and approved Retrovir as the first HIV/AIDS treatment by 1987 (Administration 2014). Despite progress, President Reagan's response is still criticized today as being too little too late. It was not until 1985 that he addressed HIV as an issue, and even then he failed to acknowledge that high-risk groups existed outside of the gay community and intravenous drug users (Richert 2009).

Between media coverage and inadequate government reaction, PLHIV were destined for a stigmatized existence. The immediate reaction of the U.S. government—silence—represents the most dangerous aspect of living with HIV. Worldwide, silence is all too often the primary way PLHIV cope with stigma. As one HIV-negative man said of his HIV-positive wife, "I was actually safe because I knew her status" (Rispel 2015). Knowledge and disclosure are the keys to coexistence with diseases like HIV/AIDS. Not only do these help PLHIV be more comfortable in society, but also allow others to better understand the needs that come with living with HIV. In this dissertation, the possible connections between awareness of HIV and stigmatizing HIV will be explored. How might social stigma borne out of ignorance affect the inclination and ability of PLHIV to obtain the necessary resources to manage HIV? And can researchers do more to help PLHIV access treatment and live more enjoyable lives?

Pathogenesis

What makes HIV such a formidable virus? As a retrovirus, HIV contains two copies of single stranded RNA. Upon entering its host, it seeks out CD4+ cells, which include macrophages, dendritic cells, and CD4+ T-cells. After gaining access to these cells, viral reverse transcriptase can copy the viral ssRNA and convert it to double stranded DNA. The viral DNA then enters the host cell's nucleus and integrates itself into the host genome. This aspect of HIV enables it to remain latent for months, even years, before becoming an active virus. Once activated, the integrated viral DNA is transcribed into RNA, which is packaged in viral proteins produced using the cell's machinery. From there, new viruses can be released from the host cells to continue the viral life cycle (MacPherson 2012). When someone with HIV has a high level of viral RNA in his or her blood, he or she is increasingly the subject of opportunistic infection. Once that person has a CD4+ count below 200 cells/mm, an HIV infection becomes a case of AIDS (CDC 2015). Current treatments are able to rid the body of actively infected cells so that the virus is undetectable, but HIV's ability to integrate complicates completely eradicating the virus. Because latent cells can survive for long periods of time, they are a constant source of the virus. Since the virus is not active in these cells and established treatments are unable to target the machinery that has not been transcribed, it has so far been impossible to truly cure PLHIV in all individuals. Even outside of latency, HIV can be highly variable, giving way to resistant strains and faster progression of the disease (Acheson 2007). Transmission of the virus is most commonly through sex and blood contact, particularly through needle sharing. HIV can also be passed through contaminated needle sticks and blood transfusions, or from mother to child during childbirth. Contrary to the popular misconception, HIV is not passed through saliva or insect vectors, such as mosquitoes (CDC 2015). Transmission is best prevented through

practicing safe sex and not sharing needles. Adherence to HIV treatments and/or pre-prophylaxis treatments (PrEP) also greatly reduces risk of transmission by either keeping the virus at an undetectable level or preventing initial infection of the virus. If someone has a high level of sexual activity, getting tested annually is recommended (Administration 2014).

Treatments

One of today's great challenges of medical research is the ongoing struggle to develop the most effective treatments to HIV with the least toxicity and lowest cost. The most common treatment regimens include three different classes of antiretroviral medications. Because HIV is notorious for its rapid mutation, these drugs are used together in a cocktail to avoid a resistant viral strain slipping through the cracks. Using a combination of medications as a way of managing HIV is called cART (combined antiretroviral therapy) or HAART (highly active antiretroviral therapy) (Prevention 2016).

In the three decades since HIV first surfaced, prevalent treatment options have branched out from the FDA's first treatment approval AZT (azidothymidine) in 1987. Classified as a nucleotide reverse transcriptase inhibitor (NRTI), AZT targets an HIV-specific enzyme called reverse transcriptase. If the function of the reverse transcriptase can be disrupted, the RNA genome contained within the viral capsid cannot be converted to DNA that can be inserted into the host cell's genome. Thus, AZT remains the reference point for most treatments developed. More than half of the available treatments for HIV target reverse transcriptase. Though having so many versions of medications with similar function may seem redundant, the variety allows better treatment plan personalization and higher accessibility. However, using NRTIs alone has proven to be insufficient in cases of viral resistance. The drugs also have a high toxicity and

therefore several unpleasant side effects (Este 2010). One of the most recent NRTI successes is the drug Truvada. It is approved for preexposure prophylaxis, meaning it can prevent HIV from truly infecting cells. This has been received as an opportunity for HIV-discordant couples and others in high risk groups to greatly reduce their risk of transmission (Prevention 2014).

Non-nucleotide reverse transcriptase inhibitors (NNRTIs) also target reverse transcriptase, but have a different mode of attack. Instead of competing with nucleotide substrates that would normally bind to reverse transcriptase as NRTIs do, it attaches to another binding site to change to render the active site useless, completely block any kind of binding. These have shown fewer side effects due to less interference with host DNA transcription machinery (De Clercq 1998).

To ameliorate the issues of side effects and resistance, protease inhibitors (PIs) have been developed to target a different area of the HIV life cycle. Rather than inhibiting genome replication, the viral proteins made as a result of HIV's successful genome replication are kept from being properly cleaved into fully functional proteins by viral proteases. Though not usually prescribed as a sole form of treatment, PIs have been shown to be more efficient in controlling viral load. While protease inhibitors can lead to viral resistance, the phenomenon is observed less often than in NRTIs (Paredes 2010). In addition, PIs are not as effective in crossing the blood-brain barrier and thus leave room for improvement (Ghosh 2006). Because PIs are effective but fall short in reaching as many tissues as NRTIs/NNRTIs, this class of drug is generally used as one of three different drugs in cART (Prevention 2016).

One of the most recent developments in cART options is the fusion inhibitor. This particular drug takes advantage of the fact that, like most viruses, HIV must bind to specific receptors on the outside of its targeted immune cells to enter the cell and hijack its machinery.

By blocking the receptors HIV uses to gain entry, fusion inhibitors prevent the virus from ever entering the target cell. With only one fusion inhibitor currently on the market, these types of medications are still largely experimental, but are expected to be highly effective for individuals with unusually resistant HIV strains. The approach fusion inhibitors take to HIV—a ligand and receptor interaction—is favored to lead the field in coming years (Fumakia 2016).

Finally, integrase inhibitors (INIs) are another new addition to HIV treatments present a new way of attack. These prevent viral DNA from being inserted into the host genome, thereby disabling the virus's ability to create viral proteins and progeny. INIs have a higher efficacy as well as a less prevalent association with viral resistance than NRTIs or PIs. These qualities make them prime for people infected with more resistant strains of HIV (Andreoni 2015).

However, these medications only tell half of the story. They serve as the first stepping stones to achieving a functional cure, which serves to keep the virus at undetectable levels in the blood without prolonged medication, thereby almost eliminating the transmission risk and symptoms of HIV without relying on adherence to medication. This strategy is a long term treatment which keeps new cells from becoming infected with extant viruses and allowing the reservoir to shrink, but not be completely eliminated. Though the current therapies discussed thus far can accomplish these undetectable levels of HIV, the therapy is lifelong and quite costly, which motivates the research for such a “cure”. The second, more idealistic approach in research is complete eradication of the virus from individuals, called a sterilizing cure. While the idea of a “total cure” is attractive, the instances in which viruses have been completely removed from the body are marginal at best. Simply put, it is not reasonable to expect a single treatment to be effective for such a virus.

Several avenues for total cures have been explored, focusing on both host and viral mechanisms. Gene editing is the basis for many recent attempts because it offers an opportunity to not only rid the host's genome of HIV-derived DNA, but also render the host cell completely impermeable to the virus. Removing integrated viral DNA is generally accomplished by using a known DNA sequence to create a target for an enzyme to cleave out. The same idea can apply to editing the cell before it is ever infected. If the DNA coding for the receptors HIV uses to gain access to the cell can be removed, the receptors themselves will never be there for HIV to use. Though this option would present a long term or even permanent treatment, actually targeting the correct genes without removing other important parts of the host genome has proved difficult (Bobbin 2015).

After cell entry and genomic integration, the next logical mechanism to target is RNA synthesis and processing. Ribozymes, or RNA sequences acting as enzymes, can seek out and destroy mRNA created as a result of HIV integrating into the host genome. A similar option known as RNA interference uses small interfering RNA (siRNA) to target viral RNA sequences (Bobbin 2015). These naturally occurring siRNAs act to silence mRNA so that the protein it codes for never comes to fruition. Though siRNA is used in preexisting host mechanisms, siRNA can be synthesized to target HIV-related mRNA (Carthew 2009). Another tactic is to create so-called RNA decoys and RNA aptamers. These bind and therefore debilitate the viral proteins by acting as inhibitors. While RNA-based approaches are safer than gene editing and are closer to being available to the public, the drawback is that most developed treatments are short term (Bobbin 2015).

Current Prevalence of Stigma

Because so little was known about HIV in the eighties, stigma closely followed the fear brought on by the mysterious disease. However, PLHIV have yet to escape a stigma created decades ago. In a 2015 study on avoidance of PLHIV at a university in the Netherlands, subjects were placed in a virtual reality setting in a hospital and were told to memorize chart information for patients afflicted with HIV, cancer, or a broken limb. Behavior around each type of patient was gauged based on interpersonal space, speed of approaching and leaving patients, and head orientation. The virtual patients also varied between homosexual and heterosexual. The study found that HIV-positive males were more frequently subjected to avoidance and stigmatizing behaviors, such as being kept at farther distances, being stared at more, and having people walk away faster than HIV-negative individuals. These behaviors were even more prevalent toward homosexual men diagnosed with either cancer or HIV, indicating a generalized stigma toward diagnosed homosexual men (Toppenberg 2015).

Though having these types of studies is useful and necessary, it does not take looking at recent peer-reviewed articles to see PLHIV and high risk groups being stigmatized. The most recent celebrity to publicly announce a positive serostatus is Charlie Sheen. That he had HIV was news in itself, but the fallout of his announcement was incredible. There was hardly a news source who did not report about Charlie Sheen's "former porn star girlfriend" being uninformed of his status (Etkin 2015). Why was it worth mentioning that his ex-partner was a sex worker before all of the information was available? Was it a covert way of saying he should have seen it coming? Other headlines surrounding HIV at the time may not stigmatize HIV directly, but have inaccurate information that could promote a flawed understanding of HIV and AIDS. Perhaps the worst offender was the ENQUIRER in its article about an unnamed celebrity's "struggle with

AIDS,” when the writer was actually referring to a recent positive HIV status. The magazine asserted that “decades of debauchery [had] finally caught up with [the celebrity]” (Jessica 2015). Another article from ENQUIRER named celebrity Danny Pintauro as being HIV positive, but called him “AIDS-stricken” instead (Anonymous 2015). These headlines spread misinformation, the stigma already surrounding HIV, and decreased willingness for PLHIV to disclose their status and get proper help (Sayles 2007). Another point of stigmatization has been the fairly recent arrival of the PReP drug Truvada, which has been celebrated as a promising way to prevent transmission in higher risk demographics. Despite this immensely positive news, some high profile people in the LBGT community were quick to point out the promiscuity such a drug might allow (Calabrese 2015). Zachary Quinto commented, “...these drugs are not to be taken to increase our ability to have recreational sex”(Berlin 2014). While he is not wrong that some may see having a “magic pill” should allow just that, he ignores the huge benefit for people, promiscuous and nonpromiscuous alike, in being able to have sex with others without the constant anxiety of possibly transmitting HIV (Calabrese 2015).

However, stigma in HIV extends well beyond the United States and western Europe. In a 2010 study by Turan, et al., it was noted that pregnant women in Kenya are less likely to get tested for HIV, keep up with antenatal prevention of HIV transmission, and seek help from maternity services when facing perceived stigma of HIV from their families and the community. Pregnant women are often the first members of their families tested for HIV, and in the event of a positive screening, can be seen as introducing the virus to their families. The study was able to confirm that a major predictor of HIV test acceptance was anticipated male partner approval or disapproval (Turan 2010). These results are important because PLHIV need to feel comfortable

in seeking knowledge and help for their condition to prevent further spread of HIV, particularly in mother-to-child scenarios and in areas that have high transmission rates.

A Survey of Stigma at UTK

Based on these reports, a survey inquiring about both HIV awareness and stigma was performed across the University of Tennessee-Knoxville student and faculty population. Respondents were recruited through email and social media, and were kept completely anonymous. The survey, provided as a supplement, first asked five questions about HIV, which included what it was, how it was transmitted, and how or if it could be effectively treated. The next five questions asked respondents to rate on a zero-to-four scale different stigmatizing statements based on how much they agreed with them. The survey also asked respondents their gender, sexual orientation, age, and what department they were in at UT. All questions and recruitment practices were approved by the Institutional Review Board. The survey was discontinued after receiving 202 responses. Ninety percent of respondents were in the 18 to 24 age range, with the other ten percent as old as 64. The sample was disproportionately female at 67%. Eighty-two percent of respondents reported being straight, with 9% reporting as bisexual and only 5% gay. The others reported being asexual, other, or preferred not to respond. Each anonymous respondent was given a “stigma score” based on the combined numbers reported for all stigma statements. Results were analyzed using a linear regression, t-tests, and nonparametric Wilcoxon tests.

Results showed that only 27% of respondents correctly answered every knowledge-based question. Ninety percent of respondents knew HIV was a virus, and 92% differentiated between HIV and AIDS. About 78% were aware antiretrovirals were used to treat HIV, but only 69%

thought the 96% efficacy rate was true. Less than half correctly answered the question about transmission correctly. When a regression was done between stigma score and correctly answered questions (Figure 1), there was no significant trend. However, there were several significant differences in stigma scores for specific questions when compared between answering profiles for transmission methods. Because the question format allowed participants to check as many options as they thought correct, there were many possible answers and thus only two groups of respondents were considered: those who answered the question about transmission completely correctly, with no fewer and no more answers than required, and those who thought every transmission mode offered was correct. Not only were the overall stigma scores significantly different between these two groups (Figure 3), there were also significant differences in their agreement with statements about food handling by PLHIV (Figure 4), proximity to PLHIV (Figure 5), and HIV being a punishment for bad behavior (Figure 6). Despite these significant relationships, there was no difference in predicted self-shaming between the two answering profiles (Figure 2). It should be noted that other questions (e.g. treatment options, the difference between HIV and AIDS, efficacy of known treatments) did not elicit the same differences in stigma.

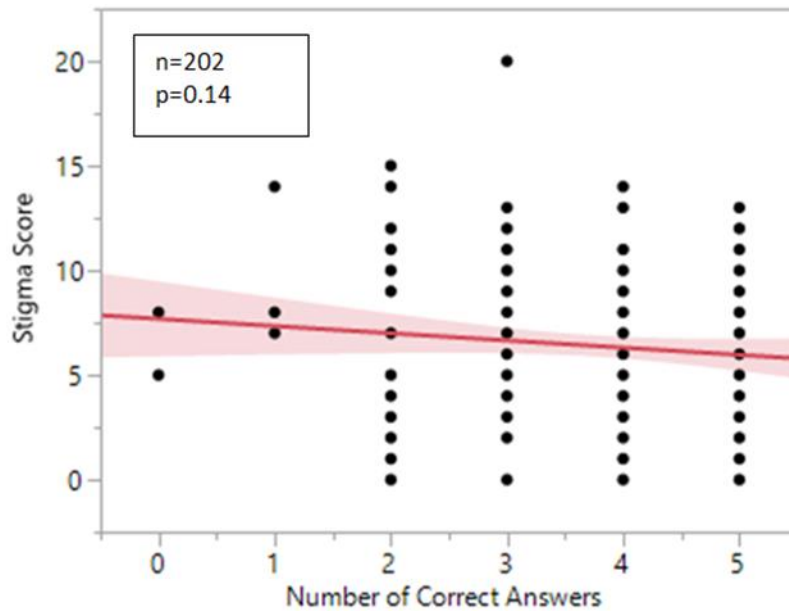

Figure 1: Overall stigma score versus number of overall correct answers. Stigma scores were calculated by adding degrees of agreement to each stigma statement together. There was no significant relationship between overall knowledge and apparent stigma when an F-test was performed ($p=0.1411$).

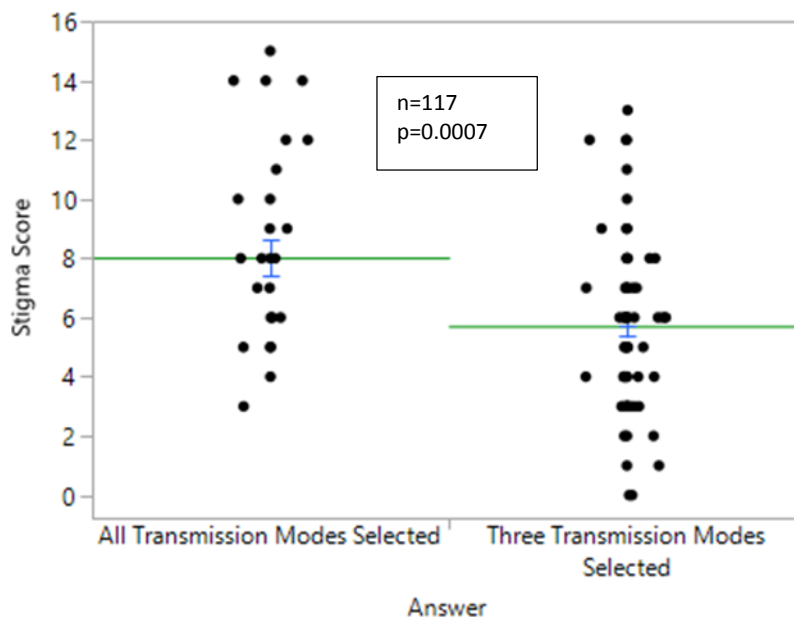

Figure 2: Stigma score compared between two groups with different awareness of how HIV can be transmitted. The “all selected” group reported that all methods listed were possible ways of transmitting the virus: contact with infected blood, unprotected sex, contact with “infected” saliva, sharing needles, and mosquitoes. The “correct” group accurately reported all legitimate modes of transmission, no more and no less. Both a t-test and Wilcox test showed a significant difference in overall stigma between these two groups ($p=0.0007$).

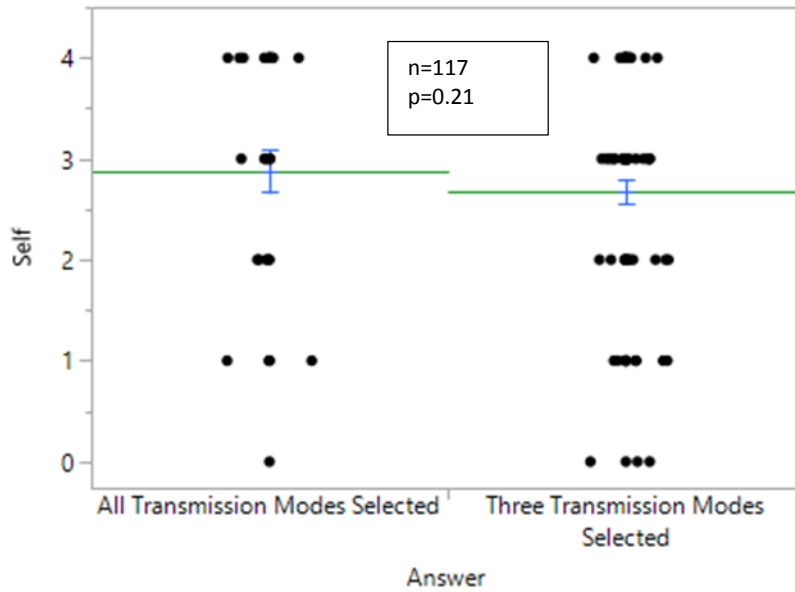

Figure 3: Predicted internal stigma compared to understanding of transmission. Sample sizes are the same as those listed in Figure 3. A t-test showed the difference to be insignificant.

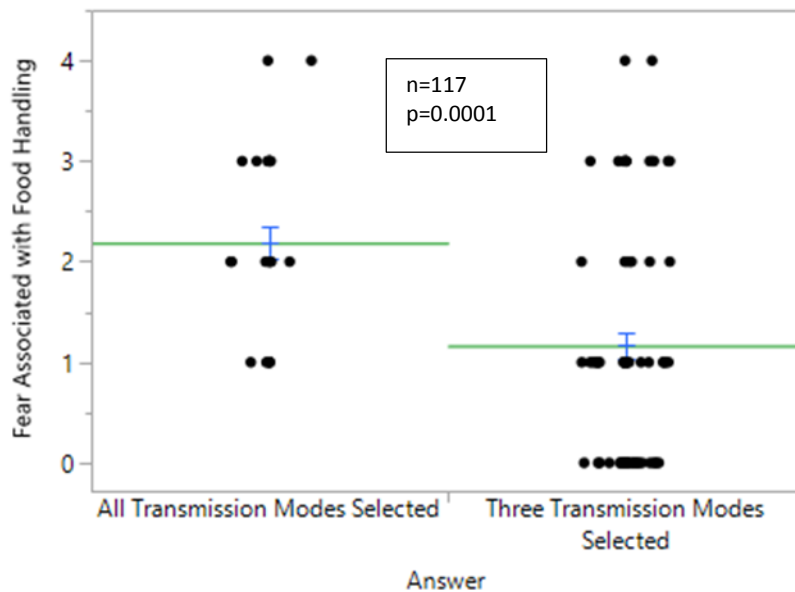

Figure 4: Fear of contracting HIV from someone living with HIV handling one's food compared between two groups with different levels of understanding of HIV transmission. Groups were the same as those stated in Figure 2. The stigma level associated with food preparation by PLHIV for each group was obtained from the stigma level reported on each survey, and then averaged. Sample sizes were the same as those used in Figure 2. Both a t-test and a Wilcox test showed there was significantly more fear of transmission within the group selecting all transmission methods listed than within the group with only correct answers (p=0.0001).

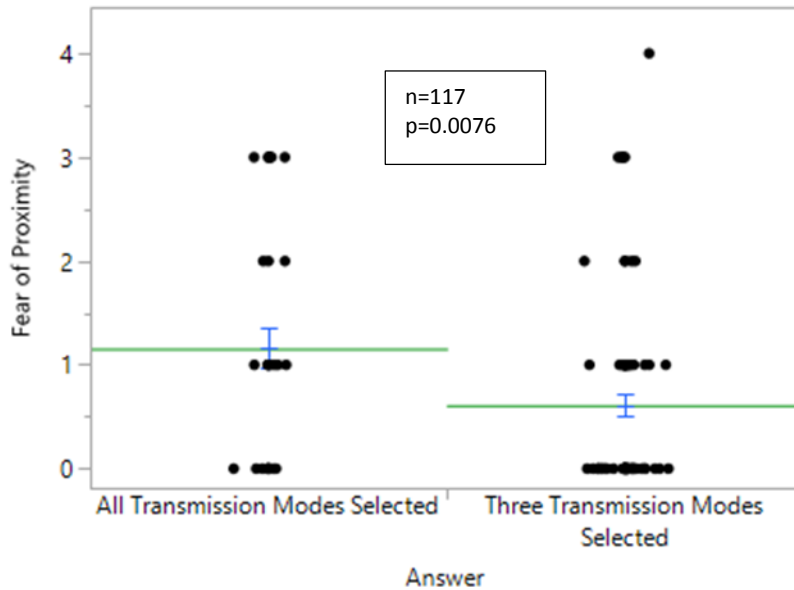

Figure 5: Fear of being in the same confined area with someone living with HIV compared between two groups. The group selecting all modes of transmission listed showed significantly higher stigma scores than those with a more accurate knowledge of HIV transmission in both a t-test and a Wilcox test ($p=0.0076$). Sample sizes were the same as those in Figure 2.

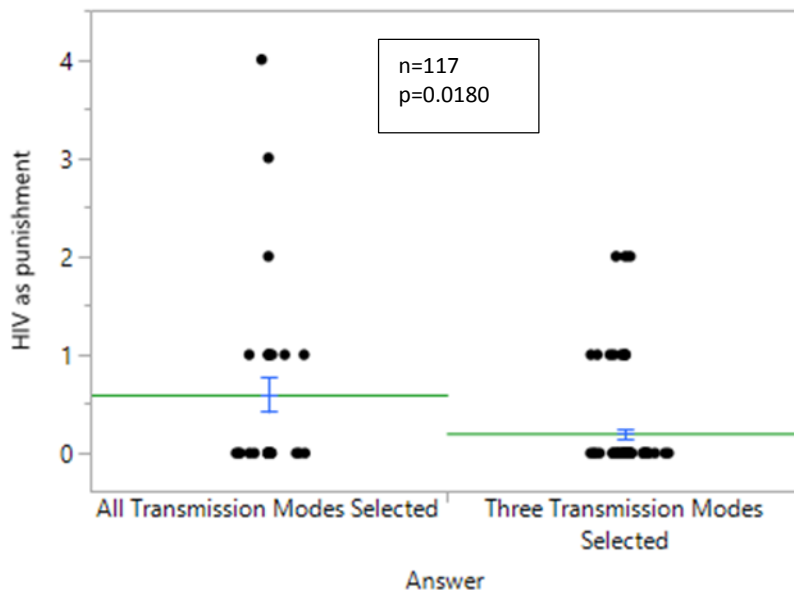

Figure 6: The average incidence of considering HIV a punishment for “bad behavior” between two groups. The group with more correct answers was less likely to stigmatize PLHIV than those seeing all modes of transmission listed as legitimate based on both a t-test and a Wilcox test ($p=0.0180$). Sample sizes were the same as those on Figure 2. However, it should be noted that few respondents fully agreed with the statement “HIV is a punishment for bad behavior.” Thus, this data should not be seen as confirming strong and widespread stigma, but rather as confirming a difference in two groups’ tendencies to not completely reject the statement.

Thus, the most pressing question surrounding these results is why one knowledge-based question would be more important in predicting stigma than others, particularly over those about the existence and efficacy of treatments. In addition, why would this trend not reflect in overall stigma? That someone who thinks they can get HIV through more than unprotected sex or blood exposure is fearful of contracting it in low risk situations makes sense. Even though it is based in inaccuracy, believing HIV is spread more easily than it actually is could foreseeably lead to more stigmatization, especially in the scope of food preparation or proximity. However, the same should arguably be true for those people who think there are no available treatments for HIV, but statistical analysis showed no significant difference between those who knew antiretrovirals are the chosen treatment for HIV and those who thought there were no available treatments. It is possible the survey design was flawed in that it asked about the efficacy of antiretrovirals after asking about what treatments were used, but did not bar respondents from editing their previous answers. However, if it is assumed the indifference would hold either way, it might be possible that there is a larger fear associated with having to live with HIV than die of AIDS. If this is the case, it speaks volumes about society's perception of HIV and acknowledged stigma surrounding HIV, as well as how little is actually known about the possibility of living a normal life with HIV. That two of the five questions were about treatment, which seemed to have no bearing on overall stigma, it is unsurprising that stigma could not be correlated with overall knowledge. That the only question correlating with stigma was about transmission suggests that HIV stigma is induced by fear of transmission, and that fear of getting HIV is borne out of an unclear understanding of the virus. However, more work would have to be done to confirm this relationship.

Though this survey did give some insight about stigma at UT Knoxville and the relationship between knowledge and stigma, there were several limitations. The survey was kept fairly short to encourage participation. A longer survey could have provided more room for comparing knowledge and stigma. Even if the survey had been kept short, different questions may have afforded more stigma than the ones used. More demographic questions could have been added to establish better trends among minorities. Much of the existing literature about stigma and HIV has evolved out of its association with homosexual men, so it would be interesting to include a larger proportion in future study groups. Between this aspect and the fact that over 60% of respondents were female, it could be beneficial to do more targeted distribution to attain a more representative sample. This approach and any future endeavors might also benefit from having a larger sample than the 202 in this survey. Finally, the location could also affect the relationship between knowledge and stigma. According to a 2011 census, a higher proportion of HIV diagnoses were in southern states, which may have implications for how much is known or what might be stigmatized in the south (Reif 2014).

Living with HIV

Various studies have looked beyond the numbers to study the tangible, day-to-day effects of living with HIV in a world that stigmatizes it. In a 2007 study conducted in Los Angeles, 48 HIV+ participants were put in groups and interviewed regarding their experiences with stigma. The study categorized these experiences as follows: innocence discourse, fear of contagion, disclosure, and negotiation of social contracts. “Innocence discourse” referred to the tendency for others to ask about how someone with HIV contracted it, and use that information to assign

blame. Women described the difficulty in handling these questions, given how deeply personal it can be. If they are not the victims of some unfortunate event such as a rape or blood transfusion, they are presumed to be promiscuous or drug-users. Homosexual men experience a similar stigma within the LGBT community, as shown by one man's experience of overhearing other gay men's disgust with HIV+ men. Despite many people assuming PLHIV inherited HIV through promiscuity or drug use, fear of contagion is another source of stigma, and what separates HIV from other chronic diseases. Though HIV is transmitted through unprotected sex or blood contact, people tend to harbor an irrational fear of contracting HIV through minimal contact. These reports are in line with the UT-Knoxville survey results showing that people who have an incorrect understanding of transmission have higher levels of stigma. Fears such as these can limit how often PLHIV can enjoy platonic physical affection, sharing home-cooked meals, or even having normal experiences with HIV-discordant friends. However, it should be noted that successfully reestablishing these interactions with family members and friends can be meaningful to someone coming to terms with his or her status, and ultimately help them resume a less isolated existence (Sayles 2007).

Adding to possible isolation is the fear of disclosure common among PLHIV. Fear of disclosing a positive serostatus arises from fear of being stigmatized, labelled, or being seen only as someone with HIV. Such fear can creep into romantic relationships, career choices, and general approach to being a part of society. Thus, PLHIV without social support have reported avoiding intimacy to avoid disclosure, quitting jobs to avoid explaining inconsistent attendance due to health issues, or avoiding enjoyable activities to avoid having to explain their situation to others (Sayles 2007, Zhang 2016).

Although studies have shown having social support helps outlook in PLHIV, stigma still affects those PLHIV who have maintained intimacy (Lee 2015, Rispel 2015). In the 2015 study from Rispel et al, researchers found 50 HIV-discordant couples distributed across three countries (Ukraine, Tanzania, and South Africa). Couples in the study gave testimonies of their experiences with the public and their own family members. Couples in Africa were labelled as being HIV-concordant and received pressure from their families to discontinue the relationship. Often, family members were confused by the couple's claims that the HIV- partner could maintain his or her negative status, despite the existence and relative accessibility of HAART. One couple in Tanzania even reported being called a "walking corpse." Couples in Ukraine experienced similar stigma, but also spoke more often of simply avoiding the subject of their discordant status out of fear of their families' reactions, or public treatment of their families based on their proximity to HIV.

Despite the fact that PLHIV can be limited by the perceived stigma in their daily lives, author Heather Boerner has captured today's possibilities for PLHIV, specifically for those in HIV-discordant relationships trying to have children. She emphasizes what can actually be accomplished with the medications available today by telling the stories of two discordant couples in which the husband was HIV+. Both couples struggled to find safe ways to fulfill their dreams of having families. Though sperm washing for in vitro fertilization was a possibility before the potential of antiretrovirals was discovered, there was a long-time ban on donating and washing the sperm of HIV+ men, killing any hopes of safely creating a child of their own. Even after the ban was repealed, the process remained expensive with little guarantee it would actually work. However, a 2001 study in Uganda found that the transmission risk during unprotected sex was directly related to viral load. The lower the treatment, the less likely transmission would

occur. In fact, the overall transmission risk per coital act was calculated being 0.1-0.2% (Gray 2001). Not long after the Uganda study, Dr. Myron Cohen began studying the effects of early antiretroviral treatment on HIV-1 transmission. Though his findings were not published until 2011, his research eventually confirmed that treating HIV as early as possible led to extremely low risks of transmission (Cohen 2011). Meanwhile, Boerner's couples were scrambling for ways to conceive children. Both couples decided to take what at the time seemed like a huge risk—waiting for an ovulation cycle, testing both blood and semen for viral load, and carefully planning Truvada treatments for the HIV- negative wife prior to having unprotected sex (Boerner 2014). Though the path was hardly easy for both couples, both were able to have healthy, HIV- negative children and keep HIV-negative partners virus-free. While these stories involved two carefully controlled situations, they are still testament to what can be accomplished given the right opportunities, and are probably the most compelling evidence for HIV becoming less of a death sentence and more a chronic illness.

Accessibility

While the fact that PLHIV have more possibilities is a tremendous and wonderful step in the right direction, the possibilities do not always become reality. The annual cost of antiretroviral treatment is staggering. Pascual gives the figure 6.5 billion USD per year to treat a mere 15 million PLHIV (Pascual 2014). Though programs like Medicaid and WHO guidelines to increase access can help offset these costs, someone with HIV, particularly those in the United States and Europe, can pay thousands of dollars per year for medications and healthcare (Koenig 2015). A major contributor to the in-going expense of antiretrovirals is the patents companies are allowed to hold for up to twenty years. During this time period, generics are not allowed to hit

the market, which keeps costs higher for long periods of time. A few loopholes have been added to global policies in an attempt to soften the financial blow in less developed countries, such as allowing other companies to begin work on generic versions of medication before the patents expire and allowing companies in other countries to manufacture and sell a patent holder's product for a certain cut of the profit (Pascual 2014). These measures have been somewhat effective in other countries, but those benefits have not extended to the United States, which remains one of the highest paying countries for pharmaceuticals (Koenig 2015). High costs can make it more difficult for people to obtain and adhere to their medications consistently, and the consequences of improper adherence to HIV medications can be serious. If medications are not taken as directed, it puts the patient at risk for not only increasing viral load above undetectable levels, but also allows a larger reservoir to form and increases the likelihood of viral resistance (Prevention 2016). Thus, if medications continue to be expensive with an ever increasing number of PLHIV, there will be a higher number of individuals needing something more advanced and even more expensive than the first line treatments available (Pascual 2014). All of this is to say that, while pharmaceutical companies must make a profit just like any other company, HIV is not a disease to be seen first and foremost as a business opportunity; rather, suppressing HIV needs to truly be the primary goal for companies worldwide.

Another important aspect of preventing HIV transmission is detecting it as soon as possible. The sooner a positive HIV status is discovered, the sooner medications can be prescribed, and the less viral load someone will incur. Even if someone recently diagnosed with HIV does not seek treatment right away for financial reasons or to evade the unpleasant side effects of antiretrovirals, being aware enough to avoid overly risky situations is important with or without medication. Therefore, access to affordable and discrete testing is pivotal. Options in the

United States include walk-in clinics, blood testing labs, and in-home oral HIV test kits. At forty dollars, test kits are less expensive than going to a clinic or lab and are cheap compared to the overall cost of being diagnosed with HIV. However, forty dollars becomes a steep price for low income demographics, particularly adolescents. In a recent study focusing on low-income adolescents in Chicago and San Francisco, teens were asked about their opinions on accessing home testing kits. Even though they can be bought at drug stores, the forty dollar price tag was a drawback, as well as the likelihood of being stigmatized or recognized while purchasing such a kit. This may be especially problematic in smaller, less urban communities where faces are more familiar and getting to a simple drug store may be more difficult. The investigators proposed a mailing service or a vending system of sorts, in which more sensitive tests could be dispensed without necessitating human interaction. Making these tests more universally available through nonprofit organizations would also reduce the cost to about \$11.00, just over a fourth of the normal cost(Catania 2015). These same strategies may benefit women in the same situation as those discussed in Turan's study in Kenya. Their decision to get tested was heavily based on their partner's reaction to a positive HIV status. Perhaps offering a more discrete testing option that could be performed without a clinic would alleviate those fears enough to increase willingness to undergo an HIV test (Turan 2010).

Conclusions

Since the 1980s, HIV has become much more a part of the global vocabulary. Since then, we have poured resources into studying the virus itself, how to keep it at bay, and how to destroy the disease entirely. Even though we are far from actually curing HIV, we have made excellent progress toward being able to coexist with it. By and large, it is access to care and perceived

stigma standing in the way of PLHIV living normal and happy lives, not so much what we have or have not accomplished in the laboratory. The anonymous couples Heather Boerner sought out are hopefully only the beginning of the successes for PLHIV. In the end, it seems PLHIV do not need a cure to achieve the same basic needs as those without HIV. And yet, the stigma still exists. Many studies, especially those from Rispel and Sayles, point toward compartmentalization and avoidance as a way of coping with HIV. We as a society seem to do the same, as common “solutions” to achieving greater testing and treatment success lies in discretion and laying low (Catania 2015). Given the difficulties in completely eradicating viruses overall, we need to be able to talk about HIV as an issue instead of sweeping it under a rug, hoping it will go away. The facts about HIV, particularly those regarding transmission and how to access treatment, need to be spread far and wide (Zhang 2016).

Though HIV has inspired a huge amount of global effort, it is not unique in its proclivity for attracting stigma. Sexually transmitted infections (STIs) have seen a similar development of stigma, and avoidance of diagnosis and treatment due to that stigma (Morris 2014). Perhaps the largest separation between HIV and other STIs is the potential of an early death and little progress on a true cure. Others can be treated with antibiotics, or at least are not liable to destroy an immune system over time. And yet there is still significant stigma surrounding these lesser diseases. Perhaps the label “sexually transmitted” has become a call for stigma, despite the constant presence of sex and sexuality in our society. Perhaps this means that eradicating HIV-related stigma is farther away than eradicating HIV itself.

As far as research goes, seeing people emulate work like the Uganda study or Dr. Cohen’s would be a breath of fresh air, simply because they worked with what was available to move mountains for HIV-discordant couples in the here and now instead of calling it impossible,

or chasing something that could be lightyears away. This is not to say progress is bad or wasteful, but it is a reminder that progress can come in many forms. Taking steps such as these to giving PLHIV the same lifestyle options as those without could go far in destigmatizing HIV. By giving PLHIV an identity other than “PLHIV,” maybe we can start seeing them as more than one decision, one life event, or one way to exist. The next step is making those scenarios outlined by Boerner possible worldwide by providing cheaper medications faster, and continued establishment of health clinics. That PLHIV can accomplish all the things they could without HIV may not change stigma right away, or even in a lifetime, but actions can speak louder than words.

References

1. Administration, F. a. D. (2014). "HIV/AIDS Historical Time Line 1981-1990." Food and Drug Administration.
2. Prevention, C. f. D. C. a. (2016). "Updated Guidelines of Antiretroviral Postexposure Prophylaxis After Sexual, Injection Drug Use, or Other Nonoccupational Exposure to HIV-United States 2016." Centers for Disease Control and Prevention.
3. Anonymous (2015). "AIDS-Stricken Danny Pintauro Thanks The Enquirer!" The National ENQUIRER.
4. Centers for Disease Control and Prevention (2016). "Updated Guidelines of Antiretroviral Postexposure Prophylaxis After Sexual, Injection Drug Use, or Other Nonoccupational Exposure to HIV-United States 2016." Centers for Disease Control and Prevention.
5. Acheson, N. H. (2007). "Fundamentals of Molecular Virology." Asia: Markono Print Media Pte Ltd.(2): 354-364.
6. Andreoni, M., Marcotullio, S., Puro, V., et al. (2015). "An update in integrase inhibitors: new opportunities for a personalized therapy? The NEXTAIM Project." *New Microbiologica* 38: 443-490.
7. Auerbach, D. M., Darrow, W.W., Jaffe, H.W., et al. (1984). "Cluster of cases of the acquired immunodeficiency syndrome: patients linked by sexual contact." *The American Journal of Medicine* 76(3): 487-491.
8. Berlin, M. (2014). "OUT100: Zachary Quinto." *OUT*.
9. Bobbin, M. C., Burnett, J.C., Rossi, J.J., et al. (2015). "RNA interference approaches for treatment of HIV-1 infection " *Genome Medicine* 7(50): 1-16.
10. Boerner, H. (2014). "Positively Negative: Love, Pregnancy, and Science's Surprising Victory of HIV." (1).
11. Brennan, R. O., Durack, D.T. (1981). "Gay Compromise Syndrome." *The Lancet*: 1338-1339.

12. Calabrese, S. K., Underhill, K. (2015). "How Stigma Surrounding the Use of HIV Preexposure Prophylaxis Undermines Prevention and Pleasure: A Call to Destigmatize 'Truvada Whores'." *American Journal of Public Health* 105(10): 1960-1964.
13. Catania, J. A., Dolcini, M.M., Harper, G.W., et al. (2015). "Self-Implemented HIV Testing: Perspective on Improving Dissemination Among Urban African American Youths." *American Journal of Public Health* 105: 5449-5452.
14. Cohen, M. S., Chen, Y.Q., McCauley, M., et al. (2011). "Prevention of HIV-1 Infection with Early Antiretroviral Therapy." *The New England Journal of Medicine* 365(6): 493-505.
15. De Clercq, E. (1998). "The role of non-nucleoside reverse transcriptase inhibitors (NNRTIs) in the therapy of HIV-1 infection." *Antiviral Research* 38: 153-179.
16. Este, J. A., Cihlar, T. (2010). "Current status and challenges of antiretroviral research and therapy." *Antiviral Research* 85: 25-33.
17. Etkin, J. (2015). "Charlie Sheen's Former Porn Star Girlfriend Says He Told Her: "I'm Clean, I'm Clean"." *Buzzfeed*.
18. Faria, N. R., Rambaut, A., Suchard, M. (2014). "The early spread and epidemic ignition of HIV-1 in human populations." *Science* 346(6205): 56-61.
19. Fumakia, M., Yang, S., Gu, J., et al. (2016). "Protein/peptide-bases entry/fusion inhibitors A nti0HIV therapies: challenges and future direction." *Reviews in Medical Virology* 26: 4-20.
20. Ghosh, A. K., Sridhar, P.R., Leshchenko, S., et al. (2006). "Structure-based design of novel HIV-1 protease inhibitors to combat drug resistance." *Journal of Medical Chemistry* 49(17): 5252-5261.
21. Gray, R. H., Wawer, M.J. , Brookmeyer, R. (2001). "Probability of HIV-1 transmission per coital act in monogamous, heterosexual, HIV-1-discordant couples in Rakai, Uganda." *The Lancet* **357**: 1149-1153.
22. Jessica (2015). "Hollywood Superstar's Desperate Battle With AIDS!" *The National ENQUIRER*.

23. Koenig, S. P., Pape, J.W. (2015). "Stemming the Tide: Can New Approaches to HIV Treatment Reverse the Trend of Rising Drug Prices in the United States?" *Clinical Infectious Diseases* 62: 792-794.
24. Lee, S., Yamazaki, M., Harris, R., et al. (2015). "Social Support and Human Immunodeficiency Virus-Status Disclosure to Friends and Family: Implications for Human Immunodeficiency Virus-Positive Youth." *Journal of Adolescent Health* 57: 73-80.
25. MacPherson, G., Austyn, J. (2012). "Exploring Immunology." Augsburg: Himmer AG(1): 90-91.
26. McKay, R. A. (2014). "'Patient Zero': The Absence of a Patient's View of the Early North American AIDS Epidemic." *Bulletin of the History of Medicine* 88(1): 161-194.
27. Morris, J. L., Lippman, S. A., Philip, S., Bernstein, K., Neilands, T. B., & Lightfoot, M. (2014). "Sexually Transmitted Infection Related Stigma and Shame Among African American Male Youth: Implications for Testing Practices, Partner Notification, and Treatment." *AIDS Patient Care & Stds* 28(9): 499-506.
28. Paredes, R., Clotet. B. (2010). "Clinical management of HIV-1 resistance." *Antiviral Research* 85(1): 245-265.
29. Pascual, F. (2014). "Intellectual property rights, market competition and access to affordable antiretrovirals." *Antiviral Therapy* 3: 57-67.
30. Reif, S. S., Whetten, K., Wilson, E.R., et al. (2014). "HIV/AIDS in the Southern USA: a disproportionate epidemic." *AIDS Care* 26(3): 351-359.
31. Richert, L. (2009). "Reagan, Regulation, and the FDA: The US Food and Drug Administration's Response to HIV/AIDS, 1980-90." *Canadian Journal of History* 43: 467-487.
32. Rispel, L. C., Cloete, A., Metcalf, C.A. (2015). "'We keep her status to ourselves': Experiences of stigma and discrimination among HIV-discordant couples in South Africa, Tanzania, and Ukraine." *Journal of Social Aspects of HIV/AIDS* 12(1): 10-17.
33. Sayles, J. N., Ryan, G.W., Silver, J.S., et al. (2007). "Experiences of Social Stigma and Implications for Healthcare Among a Diverse Population of HIV Positive Adults." *J Urban Health* 84(6): 814-828.

34. Shilts, R. (1987). "And the Band Played On: Politics, People, and the AIDS Epidemic." New York: St. Martin's Press.
35. Toppenberg, H. L., Bos, A.E.R., Ruiter, R.A.C., et al. (2015). "HIV-related stigma in social interactions: Approach and avoidance behavior in a virtual environment." *European Journal of Social Psychology* 45: 169-179.
36. Turan, J. M., Bukusi, E.A., Onono, M., et al (2010). "HIV/AIDS Stigma and Refusal of HIV Testing Among Pregnant Women in Rural Kenya: Results from the MAMAS Study." *AIDS and Behavior* 15(6): 1111-1120.
37. US Public Health Services (2014). "PREEXPOSURE PROPHYLAXIS FOR THE PREVENTION OF HIV INFECTION IN THE UNITED STATES –2014." US PUBLIC HEALTH SERVICE: 6.
38. Zhang, C., Li, X., Liu, Y., et al. (2016). "Emotional, physical, and financial burdens of stigma against people living with HIV/AIDS in China." *AIDS Care* 28: 124-131.

Supplement: HIV Awareness and Stigma Survey

1. What is HIV?
 - a. Cancer
 - b. A virus
 - c. A genetic disorder
 - d. Bacterial infection
 - e. A parasite

2. Which of the following are ways HIV can be transmitted?
(Check all that apply)
 - Contact with HIV-positive blood
 - Unprotected sex
 - Contact with saliva from someone with HIV
 - Sharing needles
 - Mosquitoes

3. How is HIV currently treated?
 - a. Antibiotics
 - b. Chemotherapy
 - c. Antiretrovirals
 - d. There are no known treatments for HIV

4. True or False: Antiretrovirals are approximately 96% effective in preventing HIV transmission when taken properly.

5. True or False: HIV is the same thing as AIDS.

6. On a scale of 0 (strongly disagree) to 4 (strongly agree), how much would you agree with this statement?

If one of my family members contracted HIV, I would be ashamed.

- 0-strongly disagree
- 1-disagree
- 2-neutral
- 3-agree
- 4-strongly agree

7. On a scale of 0 (strongly disagree) to 4 (strongly agree), how much would you agree with this statement?

If I contracted HIV, I would be ashamed of myself.

- 0-strongly disagree
- 1-disagree

- 2-neutral
- 3-agree
- 4-strongly agree

8. On a scale of 0 (strongly disagree) to 4 (strongly agree), how much would you agree with this statement?

If someone living with HIV were to prepare my food, I would fear contracting HIV.

- 0-strongly disagree
- 1-disagree
- 2-neutral
- 3-agree
- 4-strongly agree

9. On a scale of 0 (strongly disagree) to 4 (strongly agree), how much would you agree with this statement?

If I were sitting in an enclosed space with someone with HIV, I would fear contracting HIV myself.

- 0-strongly disagree
- 1-disagree
- 2-neutral
- 3-agree
- 4-strongly agree

10. On a scale of 0 (strongly disagree) to 4 (strongly agree), how much would you agree with this statement?

HIV is a punishment for bad behavior.

- 0-strongly disagree
- 1-disagree
- 2-neutral
- 3-agree
- 4-strongly agree

11. How old are you?

12. What is your gender?

13. What is your sexual orientation?

14. If you are student or faculty, what department are you in?

Role in Project

The Principal Investigator, Renee Adamec, conducted a survey of the University of Tennessee-Knoxville's students and faculty to try to correlate knowledge and stigma surrounding HIV. She also reviewed scientific literature to inspire the survey, explain results, and suggest a new perspective on HIV.

Acknowledgments

I would like to acknowledge my thesis advisor, Dr. Vitaly Ganusov for his direction in this project, as well as the University of Tennessee students and faculty for making this project possible.