



Southeastern Fishes Council Proceedings

Number 52 (December 2010)

12-1-2010

Number 52 (December 2010)

Southern Fishes Council

Follow this and additional works at: <http://trace.tennessee.edu/sfcproceedings>



Part of the [Marine Biology Commons](#)

Recommended Citation

Southern Fishes Council (2010) "Number 52 (December 2010)," *Southeastern Fishes Council Proceedings*: No. 52.
Available at: <http://trace.tennessee.edu/sfcproceedings/vol1/iss52/1>

This Full Issue is brought to you for free and open access by Trace: Tennessee Research and Creative Exchange. It has been accepted for inclusion in Southeastern Fishes Council Proceedings by an authorized administrator of Trace: Tennessee Research and Creative Exchange. For more information, please contact trace@utk.edu.

Number 52 (December 2010)

Abstract

(December 2010) - Comparative Conservation Genetics of Two Endangered Darters, *Percina rex* and *Percina jenkinsi* By Anna L. George, David Neely, and Richard Mayden

Invasion of Gulf Menhaden in the Alabama River By T. Heath Haley, R. Kyle Bolton, and Carol E. Johnston

Southeastern Fishes Council State Reports

Minutes, Business Meeting, 35th Annual Meeting, Southeastern Fishes Council

2009 Treasurer's Report for the Southeastern Fishes Council

Keywords

conservation, genetics, endangered, darters, fishes, *percina rex*, *percina jenkinsi*, gulf menhaden, alabama river

Southeastern Fishes Council Proceedings

Dedicated to the Conservation of Southeastern Fishes

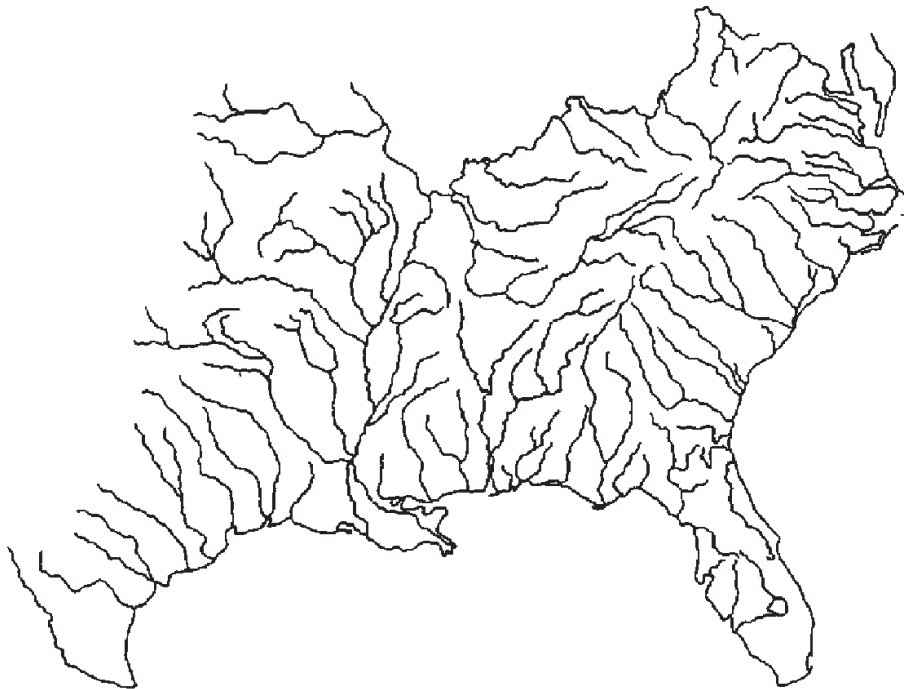

CONTENTS

Comparative Conservation Genetics of Two Endangered Darters, <i>Percina rex</i> and <i>Percina jenkinsi</i> <i>Anna L. George, David A. Neely, and Richard L. Mayden</i>	1
Invasion of Gulf Menhaden in the Alabama River <i>T. Heath Haley, R. Kyle Bolton, and Carol E. Johnston</i>	13
Southeastern Fishes Council State Reports	19
Minutes, Business Meeting, 35th Annual Meeting, Southeastern Fishes Council	39
2009 Treasurer's Report for the Southeastern Fishes Council	43

Annual Dues

Please check your mailing label. Opposite your name on the mailing label is the last year for which we have a record of dues paid (or "9999" for lifetime members). If you have not yet paid 2010 dues (or other dues in arrears), please send a check payable to *Southeastern Fishes Council* to Anna George, Tennessee Aquarium, 1 Broad St., Chattanooga, TN 37402, phone (423) 785-4171. Dues are \$30.00 per year for regular members and \$15.00 per year for students. If you are uncertain regarding your status, email Anna George at alg@tnaqua.org

36th Annual Meeting, Southeastern Fishes Council

The SFC met in Athens, GA on Thursday and Friday, the 11th and 12th of November, 2010. The meeting program and abstracts are posted on our website <www.sefishescouncil.org>.

Student Award Winners

Oral Presentations

1st Place: James H. Roberts, Virginia Tech. Extensive dispersal of Roanoke logperch inferred from genetic marker data (with Paul L. Angermeier and Eric M. Hallerman)

2nd Place: Andrea Fritts, University of Georgia. Development of a non-lethal approach for assessing stress in freshwater mussels (with James T. Peterson and Robert B. Bringolf)

3rd Place: Brook Fluker, University of Alabama. Genetic divergence and sympatric occurrence of the spring inhabiting coldwater darter (*Etheostoma ditrema*) and an undescribed stream inhabiting form (*E. sp. cf. ditrema*) (with Bernard R. Kuhajda and Phillip M. Harris)

Poster Presentations

1st Place: Kerstin Edberg, St. Louis University. Genetic isolation as a result of dam construction: A look at the effects on two species of darters (with Philip Lienesch, Jeffrey Marcus, Robert Wood)

2nd Place: Jane Argentina, Virginia Tech. Genetic structure and diversity of variegated darters (*Etheostoma variatum*) in the Big Sandy River drainage (with Paul L. Angermeier, Eric M. Hallerman, and Joanne E. Printz)

3rd Place: Andrew Taylor, University of Georgia. Dispersal of non-native smallmouth bass in the Chattahoochee River (with Douglas L. Peterson)

Comparative Conservation Genetics of Two Endangered Darters, *Percina rex* and *Percina jenkinsi*

ANNA L. GEORGE^{1,2*}, DAVID A. NEELY¹, AND RICHARD L. MAYDEN²

¹Tennessee Aquarium Conservation Institute,
1 Broad St., Chattanooga, TN 37402 USA;

²Department of Biology, St. Louis University,
St. Louis, MO 63103 USA

*Corresponding author: alg@tnaqua.org

ABSTRACT

Within the logperch group, a clade of 10 darter species from North America, two species are afforded federal protection. *Percina rex* is found in four major systems of the Roanoke and Chowan river drainages, and *Percina jenkinsi* is restricted to less than 45 river kilometers of the Conasauga River. Two complete mitochondrial genes, NADH dehydrogenase subunit 2 and cytochrome *b*, were sequenced to assess genetic diversity and conservation status of these two species. Levels of haplotype diversity were higher in *P. rex* ($h = 0.919$) than *P. jenkinsi* ($h = 0.889$), but nucleotide diversity was higher in *P. jenkinsi* ($p = 0.00485$) than *P. rex* ($p = 0.00367$). Four haplogroups were recovered in *P. rex*, and two distinct clades of haplotypes were recovered from phylogenetic analysis of *P. jenkinsi*. These results are interpreted as reflecting differing causes of decline for the two logperch species: recent geographic fragmentation with subsequent bottleneck events in *P. rex* versus a historical bottleneck of the restricted *P. jenkinsi*. Within *P. rex*, a combination of natural isolation of subpopulations in different tributary systems and recent anthropomorphic fragmentation of the drainage is likely responsible for observed patterns of differentiation among the extant populations. *Percina jenkinsi* is at far greater risk of extinction, and both the species and its habitat are in need of immediate conservation actions.

INTRODUCTION

Aquatic vertebrates are imperiled at rates twice as high as terrestrial species (Richter et al., 1997). Drainages of the southeastern U.S. contain a particularly diverse and imperiled ichthyofauna (Master, 1990; Burr and Mayden, 1992; Lydeard and Mayden, 1995; Warren et al., 2000). Etnier (1997) identified the top three causes of imperilment of this fauna to be nonpoint-source pollution, alteration of water flow, and small native range. Fishes with habitat preferences of medium-sized rivers are disproportionately affected. While these habitats support only 20% of southeastern fish species, they contain 40% of the fishes considered imperiled from all habitats (Etnier, 1997). Two families of fishes exhibiting close associations with these habi-

tats, the Ictaluridae and Percidae, have disproportionately higher percentages of jeopardized species than other southeastern fish families (Etnier and Starnes, 1991; Etnier, 1997).

Within the family Percidae, darters are a clade of over 200 species of smaller-bodied fishes endemic to eastern North America (Song et al., 1998; Sloss et al., 2004). While the relationships within this group have been the subject of considerable debate (Near, 2002; Sloss et al., 2004; Lang and Mayden, 2007), one group consistently recovered is a clade of logperches of the genus *Percina*, subgenus *Percina* (Near, 2002). The 10 described species of logperch are ideal for comparative conservation genetics studies due to their rapid diversification rates (Near and Benard, 2004) and a broad disparity in rarity and abundance, from extremely common and broadly distributed taxa to critically rare and localized endemics. The clade is characterized by an elongate and conical snout, a pigmentation pattern consisting of tiger-stripe bars, and the behavioral synapomorphy of rock-flipping. Individuals use their conical snout to turn over rocks and gravel to prey upon hiding macroinvertebrates (Jenkins and Burkhead, 1994), a behavior unique among darters. Because this feeding strategy requires nonembedded gravel or cobble substrates, logperch are negatively affected by siltation (Rosenberger and Angermeier, 2003). The two basal most species in this group, *Percina rex* (Jordan and Evermann) and *Percina jenkinsi* Thompson, are the only two in the subgenus listed as Federally Endangered (Near, 2002; Near and Benard, 2004; George et al., 2006).

Percina rex, the Roanoke Logperch, was described from the upper Roanoke River in 1889 (Jordan, 1889), but not widely considered a valid species until the late 1960s (Jenkins and Burkhead, 1994). Until 2006, *P. rex* was only known from four river systems in Virginia (Fig. 1; Jenkins and Burkhead, 1994). Three of these systems, the Roanoke, Pigg, and Smith rivers (Roanoke River drainage), are separated from the fourth, Nottoway River (Chowan River drainage), by Albemarle Bay. This disjunct distribution has been invoked as evidence for the loss of many populations across the Piedmont physiographic province over the past 150 years (Jenkins and Burkhead, 1994). This hypothesis was supported through the recent

discovery of *P. rex* in several other systems of the Roanoke River drainage: Goose Creek and Big Otter River in the middle Roanoke River and Mayo River and downstream Smith River in North Carolina (Rosenberger, 2007; Roberts et al., 2009). The most recent management plan for *P. rex* recognizes six populations: upper Roanoke River, middle Roanoke River, Pigg River, Smith River upstream of Philpott Reservoir, Smith River downstream of Philpott Reservoir, and Chowan Reservoir (Rosenberger, 2007). The populations in the Mayo and Smith rivers in North Carolina had not been discovered yet (Roberts et al., 2009).

Of the four populations of *P. rex*, the one in the upper Roanoke River has consistently been considered the healthiest (Jenkins and Burkhead, 1994). Visual surveys in 2000 and 2001 found the population in the Chowan River drainage may be equally robust (Rosenberger and Angermeier, 2003; Rosenberger, 2007). Many populations are now affected by downstream impoundments, which alter riverine habitat and connectivity. Concerns about the status of *P. rex* were first vocalized in the 1970s, as chemical spills and proposed dams threatened the species, especially the population in the upper Roanoke River (Jenkins and Burkhead, 1994). Though *P. rex* was listed as Federally Endangered in 1989 (U.S. Fish and Wildlife Service, 1989), critical habitat has not been designated.

Percina jenkinsi, the Conasauga logperch, is one of the rarest fish in North America. It is known only from approximately 50 specimens taken from a 44-km reach of the Conasauga River, a tributary of the Coosa River in the Mobile Basin (Fig. 2), near the Georgia/Tennessee state line (Etnier and Starnes, 1993; Kuhajda et al., 2009). While no historical collections suggest that *P. jenkinsi* was previously more widely distributed (Thompson 1985), it is unusually restricted when compared to other Coosa River endemics. Most fishes in the Conasauga River are also shared with the adjacent Coosawattee and/or Etowah rivers (Mettee et al., 1996). The earliest survey of the upper Coosa River was in 1877, by which point agricultural development and extensive deforestation during the Civil War had dramatically altered the landscape (Jordan, 1877). *Percina jenkinsi* was not collected until the stretch of the Conasauga River it currently inhabits was first surveyed in 1969 (Thompson, 1985). It is hypothesized to be restricted by competition with a sympatric member of the subgenus, *Percina kathae* Thompson, which is widespread throughout the Mobile Basin (Thompson, 1985). Due to its extremely restricted distribution, *P. jenkinsi* was listed as Federally Endangered shortly after its description in 1985 (U.S. Fish and Wildlife Service, 1985).

The Conasauga River is known for a high number of endemic and imperiled aquatic species (Etnier and Starnes, 1993; Burkhead et al., 1997). While the Mobile Basin, and the Coosa River in particular, once supported the largest diversity of freshwater mollusks and snails in the world (Abell et al., 2000), the construction of six main stem dams, particularly Weiss and Logan Martin in the

1960s, caused one of the largest extinction events in the United States when at least 39 species of mollusks were lost (Folkerts, 1997; Neves et al., 1997). Many imperiled fishes found in the Conasauga River (*Cyprinella caerulea* (Jordan), *Noturus munitus* Suttkus and Taylor, *Etheostoma ditrema* Ramsey and Suttkus, *Etheostoma trisella* Bailey and Richards and *Percina antesella* Williams and Etnier) are now isolated from other extant populations in the Mobile Basin by impoundments, with little opportunity for dispersal. Though the Conasauga River has been designated as critical habitat for 11 federally listed species, and much of the headwaters drain National Forest, nonpoint-source pollution from agriculture and road construction continues to increase sedimentation and threaten the fauna (Burkhead et al., 1997; Parmalee and Bogan, 1998). Subsequent urban sprawl from Atlanta has further jeopardized the region; the Conasauga and Etowah rivers contain a higher proportion of imperiled aquatic species than any similarly sized system in the southeastern United States (Burkhead et al., 1997).

While there are no historical records indicating that either *P. rex* or *P. jenkinsi* ever occupied larger ranges, the occurrence of sympatric taxa with more widespread distributions suggests that their rarity may be relatively recent. If these species have only recently become rare, conservation strategies should seek to halt their recent decline by increasing available habitats to augment population size and prevent extinction (Hanski, 1998). However, if these species have always been spatially rare or geographically fragmented, conservation activities must be more carefully undertaken to preserve natural population size, structure, and dynamics. The objective of this study is to use genetic data to infer historical distributions, movement and population sizes, as well as to assess the relative conservation status of *P. rex* and *P. jenkinsi*.

METHODS

Logperch were collected by seining and/or electrofishing. Sampling localities and numbers collected are shown in Table 1. Five of the six management populations for *P. rex* from all four major systems were sampled (Rosenberger, 2007). Because the sample sizes for the management populations in the Smith River were small and are only separated by Philpott Reservoir (constructed in 1953), they were combined for these analyses. Each major system (Roanoke, Pigg, Smith, and Chowan) was therefore treated as a population.

Fish were anesthetized with MS-222, and approximately 1 cm² of the distal portion of the second dorsal fin was removed prior to release of the fish. Photo vouchers are available from the lead author. DNA was extracted, amplified, and sequenced using methods described in George et al. (2006). Sequences were verified by consensus between the two strands, edited and aligned by eye using BioEdit v5.0.9 (Hall, 1999). Veracity of all mutations was assessed

via examination of the electropherograms. For *P. rex*, haplotype H is accessioned as GenBank AF386556 and AY770857, haplotype A is accessioned as GenBank DQ493478 and DQ493523, and haplotype N is accessioned as GenBank DQ493479 and DQ493524. For *P. jenkinsi*, haplotype F is accessioned as GenBank AF386555 and AY770852, haplotype A is accessioned as GenBank DQ493480 and DQ493525 and haplotype B is accessioned as GenBank DQ493481 and DQ493526. All other haplotypes are available on GenBank as numbers EU293554–EU293585.

Genetic diversity and population structure—Haplotype diversity (Nei and Tajima, 1981) and nucleotide diversity (Nei, 1987) were calculated using DNAsp (Rozas et al., 2003). DNAsp was also used to test for historical population changes and neutral mutation using Tajima's (Tajima, 1989) and Fu and Li's tests (Fu and Li, 1993). Haplotype networks were constructed using TCS 1.13, using combined ND2 and *cyt b* sequences with no ambiguous positions and a confidence limit of 95% (Clement et al., 2000). Networks were constructed separately for each species in order to represent multifurcating relationships between haplotypes.

Differentiation between populations of *P. rex* was examined in Arlequin by calculating pairwise f_{st} values and an AMOVA under a distance model of sequence evolution (Excoffier and Lischer, 2010). The correlation between pairwise f_{st} values and geographic distance was calculated using a Mantel test in Arlequin with 1000 permutations of the pairwise distance matrix to test for significance. River distances (km) for the Mantel test were measured from 1:100,000 scale basemaps (U.S. Geological Survey) of the drainage and follow the old river channel in impounded reaches. For river systems with multiple sampling sites, the most downstream locality was used to calculate distance.

Phylogenetic analysis—Incongruence-length difference analyses (Farris et al., 1994), as implemented in PAUP* (Swofford, 2002) with 100 replicates and uninformative characters removed (Lee, 2001), were used to test for homogeneity among *cyt b* and ND2 partitions. Relationships between 10 species in the subgenus *Percina* were inferred under parsimony analysis (MP), utilizing the heuristic search option in PAUP* with ACCTRAN and tree-bisection-reconnection during 100 replicates of random sequence addition. MP analyses were conducted with molecular characters unweighted and unordered. All minimal-length trees were kept, and zero-length branches collapsed. Support for individual nodes was assessed by performing 1000 jackknife replicates with 37% data deletion in each replicate and JAC emulation selected and calculating decay indices (Bremer, 1994) using TreeRot (v2, M. D. Sorenson, Boston University, Boston, MA, 1999, unpubl.). Additional members of the subgenus *Percina* were included in phylogenetic analyses (George et al., 2006), and outgroup taxa included *Percina macrocephala* (Cope), *Percina aurantiaca* (Cope), *Percina evides* (Jordan and

Copeland) and *Percina roanoka* (Jordan and Jenkins), as suggested by Near (2002) and Sloss et al. (2004).

RESULTS

Genetic diversity and population structure—Genetic variation within *P. rex* was high, with an overall haplotypic diversity (h) of 0.919 and nucleotide diversity (p) of 0.00367. Individual populations ranged from $h = 0$ –0.978, $p = 0$ –0.00314 (Table 2). Fourteen different haplotypes were recovered among the 29 *P. rex* analyzed. The population in the Pigg River was monomorphic while the other three populations contained at least one haplotype (Table 1). Pairwise distance values between the haplotypes ranged from 0.046% to 0.6%. The populations in the Roanoke and Smith rivers shared two haplotypes (F and I). No other haplotypes were shared among populations. Neither Tajima's D (0.063), nor Fu and Li's D^* (-0.037) or F^* (0.053) values were significant, indicative of demographically stable populations. An AMOVA using a distance model of evolution was conducted using the Roanoke and Chowan drainages as groups based upon their separation by Albemarle Bay. Significant genetic variation was recovered between and within populations, but not between groups ($f_{sc} = 0.498$, $f_{st} = 0.425$, $f_{ct} = 0.0767$, $p < 0.01$ for all but f_{ct}). Pairwise f_{st} values range from 0.31 (Pigg and Smith rivers) to 0.76 (Roanoke and Pigg rivers). The Mantel test did not reveal a significant correlation between geographic distance and pairwise f_{st} values for the populations ($Z = 1991.5$, $r = 0.143$, $p = 0.65$).

Six different haplotypes were recovered among the nine *P. jenkinsi* sequenced (Table 1), with pairwise distance values from 0.046% to 0.9%. While haplotype diversity was lower than that observed in *P. rex* ($h = 0.889$), nucleotide diversity was higher ($p = 0.00485$). In *P. jenkinsi*, significantly positive values of Tajima's D (2.17) and Fu and Li's F^* (1.76) indicate an excess of intermediate frequency haplotypes. The Fu and Li's D^* value of 1.38, while positive, was not significant.

Haplotype networks recovered four groups of haplotypes within *P. rex* (Fig. 3). The most diverse cluster contained nine haplotypes from the Roanoke and Smith rivers. Another was composed of a single haplotype found in individuals from both the Roanoke and Smith Rivers. The third contained two haplotypes found in individuals from the Pigg and Smith rivers, and the final contained two haplotypes from the population in the Chowan River. Analysis of *P. jenkinsi* haplotypes revealed two distinct clusters of three haplotypes each (Fig. 4), with up to 0.9% pairwise distance between the most divergent haplotypes, A and F. There was no geographic concordance with the distribution of these clades within their occupied range in the Conasauga River.

Phylogenetic analysis—The incongruence-length difference test revealed no significant heterogeneity between the individual genes ($p = 0.66$), thus, *cyt b* and

ND2 alignments were concatenated into a single data set totaling 2187 bp. Of these, 575 were variable and 397 were parsimony informative. Maximum parsimony analysis recovered nine trees (Fig. 5; length = 1011, CI = 0.694, RCI = 0.654). Consistent with previous analyses (Near, 2002; Near and Bernard, 2004; George et al., 2006), *P. rex* was recovered as the most basal logperch. All *P. rex* haplotypes formed a monophyletic group with 100% jackknife support. Support for groups within the tree was weak, except for strong support of a clade consisting of a monomorphic population in the Pigg River sister to a haplotype present in the population in the Smith River. A strong relationship between tree topology and geography was not recovered. While the populations from the Pigg River and the Chowan River formed monophyletic groups, haplotypes from the Roanoke River and Smith River were not resolved in a single clade. *Percina jenkinsi* was recovered as the second most basal species, sister to a clade containing the remaining members of the subgenus *Percina*. All six *P. jenkinsi* haplotypes formed a monophyletic group with 100% jackknife support. Within the species, two monophyletic clades were recovered, with 99% and 100% jackknife support and decay values of 4 and 10, respectively. Pairwise distance values between derived members of the subgenus (excluding *P. rex*, *P. jenkinsi*, and *Percina burtoni* Fowler) ranged from 0.78% (*Percina austroperca* Thompson and *P. kathae*) to 2.37% (*Percina carbonaria* (Baird and Girard) and *P. austroperca*).

DISCUSSION

The genetic signatures observed in *P. rex* and *P. jenkinsi* are quite different, and likely reflect the differing factors impacting genetic diversity in imperiled taxa. Genetic diversity in *P. rex* is high, particularly within the populations in the upper Roanoke and Smith rivers. These populations contain 11 of the 14 recovered haplotypes, which are distributed in three of the four clusters of the haplotype network (Fig. 3). Correspondingly, they also contain the highest nucleotide diversity within *P. rex* (Table 2). The upper Roanoke and Smith rivers are also the only populations with shared haplotypes (Table 1; Fig. 3). These numbers likely reflect the historical abundance and distribution of *P. rex* in the Roanoke River drainage. The recent discovery of *P. rex* in upstream intervening reaches of the Roanoke River drainage (Fig. 1), also suggests that dispersal would be facilitated between these populations.

The population in the Pigg River is fixed for haplotype J which is most similar to haplotype K found in the population in the Smith River. Given the geographic proximity of the Pigg River to the Roanoke and Smith rivers, the recent discovery of populations in intervening reaches, and the shared fauna with the upper Roanoke River (Jenkins and Burkhead, 1994), it is likely that the low genetic variation in the population in the Pigg River reflects either small sample size or a recent bottleneck. Only 15 individuals were captured during extensive surveys from this system from the 1960s through the 1980s

(Jenkins and Burkhead, 1994). The construction of Smith Mountain Reservoir (1963) and Leesville Reservoir (1963) likely has prevented immigration from supplementing this population and maintaining higher levels of diversity during bottleneck events (Fig. 1).

The population in the Chowan River also contained less genetic diversity. Only two haplotypes were recovered from the four individuals sampled. Recent surveys of this drainage indicate a large population of sub-adults (Rosenberger and Angermeier, 2003). Small sample size for genetic analysis is likely responsible for the lower recovered genetic diversity. The differentiation between populations in the Roanoke and Chowan river drainages suggests moderately long isolation, as supported by the presence of Albemarle Bay. Maintaining the population in the Chowan River drainage is extremely important due to the unique geographic position and divergent haplotypes.

One of the persistent questions about *P. rex* has been whether its disjunct distribution in the Roanoke and Chowan river drainages is due to recent extirpation or historical range restriction. Other sympatric and endemic taxa in the Roanoke and Chowan river drainages, such as *Moxostoma ariommum* Robins and Raney, *Noturus gilberti* Jordan and Evermann and *Ambloplites cavifrons* Cope, also exhibit a similar, though slightly expanded, distribution in the Piedmont. Jenkins and Burkhead (1994) hypothesized that the current distribution of *P. rex* is due to extirpation of many Piedmont populations in the past 150 years. If so, the absence of historical records from elsewhere in the middle Roanoke or Dan rivers may be tied to a paucity of collections from these areas prior to the 1960s. Since then, main stem habitats in much of this area have been impacted by impoundment of Smith Mountain Reservoir (1963), Leesville Reservoir (1963) and John H. Kerr Reservoir (1953) and subjected to considerable fluctuations in flow, thermal, and turbidity regimes. Though these results are inconclusive on the question of recent range contraction in *P. rex*, the shallow branches in the phylogram, non-significant Mantel test, and shared haplotypes between the Smith River and Roanoke River are indicative of recent gene flow. As suggested by these genetic data and new records for *P. rex* throughout the Roanoke River drainage, the species could have occupied a much wider distribution throughout the Piedmont region (Burkhead, 1983; Rosenberger, 2007; Roberts et al., 2009).

Despite this increase in known range size for *P. rex*, it is clear that connectivity is now a major conservation concern. There is currently no chance for dispersal between and even within most river systems due to impoundments in intervening reaches. Currently, the species is vulnerable, yet stable. Efforts at conservation should be targeted at increasing available habitat for all populations. The Roanoke River population appears to be currently stable and genetically healthy, but is of high importance due to its high genetic diversity. Protection of this reach also ensures the survival of a broad spectrum of other imperiled aquatic taxa with restricted distributions, including *N. gilberti* and *M. ariommum*.

In contrast to *P. rex*, the patterns of variation found within *P. jenkinsi* are much more unusual. The haplotype diversity within *P. jenkinsi* is lower than *P. rex*, which is unsurprising given its smaller range and population size. However, the nucleotide diversity of *P. jenkinsi* is higher than that seen in *P. rex*. Two distinct clades of haplotypes were recovered within *P. jenkinsi* (Fig. 5), and pairwise distance values for the most divergent haplotypes in these clades are 0.9%, compared to only 0.6% within *P. rex* and 0.78% between two described members of the subgenus (*P. kathae* and *P. austroperca*). There is no geographic or temporal congruence with the distribution of haplotypes in the Conasauga River. Divergent haplotypes were even recovered from the same collection (Table 1).

Because the range size and population size of *P. jenkinsi* is much smaller than that of *P. rex*, we expected that all measures of genetic diversity would be much lower given the impacts of rarity on genetic drift and fixation (Franklin, 1980). However, the high nucleotide diversity may still be indicative of a species at greater risk of decline than its congener. Significantly positive values from both Tajima's D and Fu and Li's F* tests indicate an excess of intermediate frequency haplotypes, suggesting either recent population reduction, collapse of two divergent populations into one, or balancing selection (Tajima, 1989). Of these three scenarios, the most likely is a recent population bottleneck, induced by human impacts on the Conasauga River and the rest of the upper Coosa River system within the past 400 years of European settlement.

Even within the past 50 years, local abundance of *P. jenkinsi* has been reduced. In 1969, the first year *P. jenkinsi* was collected, 20 specimens were vouchered in southeastern museums, including eight in a single collecting effort (Thompson, 1985). Over the past 20 years, numbers of *P. jenkinsi* observed during surveys of the Conasauga River has declined from 1–6 individuals per riffle to 1–3, and many riffles no longer support any *P. jenkinsi* (B.J. Freeman and M.C. Freeman, pers. comm.). Increased erosion and associated sedimentation, agricultural run-off, and excessive drought all threaten the system (Freeman et al., 1996). Human activities within the Conasauga River system could have resulted in a recent population bottleneck, resulting in two divergent clades of haplotypes based on random loss and drift. Similar to a recent bottleneck, these two clades could also be the result of a collapse of two populations into one. However, this seems less likely because haplotypes from both clades are distributed throughout the river, there is no data to support a more widespread distribution for *P. jenkinsi*, and there is no geological evidence for a barrier to gene flow within the Conasauga River.

Balancing selection can also result in a significantly positive Tajima's D value. If *P. jenkinsi* has always been restricted in its current distribution in the Conasauga River, assortative mating would have the benefit of minimizing inbreeding and maintaining diversity in a small population (Edwards and Hedrick, 1998). However, without evidence of balancing selection on the diploid genome, the

high nucleotide diversity and positive Tajima values recovered in *P. jenkinsi* are most likely due to a recent population bottleneck. Regardless of the cause of the high genetic diversity within *P. jenkinsi*, it is clear that recovery depends solely on reversing the recent declines of the species in the Conasauga River in order to preserve the current genetic diversity levels.

Comparative phylogenetic examination of the genetic diversity within these closely related logperch allows a better understanding of the conservation problems these species are facing. Within *P. rex*, recent habitat alteration has resulted in the reduction of gene flow between all extant populations. The recent discoveries of populations of *P. rex* in some intervening reaches help explain shared haplotypes and presumably recent gene flow between the populations in the Roanoke and Smith rivers. Conservation activities must target expanding the range of *P. rex* throughout the Roanoke River drainage in order to decrease fragmentation, augment declining populations, and restore patterns of movement. Limited translocation between populations in the Roanoke River may restore natural levels of gene flow and higher diversity values within populations. This species is more stable than *P. jenkinsi* as supported through data from range sizes, abundances in previous surveys, and this genetic data (Rosenberger and Angermeier, 2003; B.J. Freeman, unpubl. data).

In contrast, *P. jenkinsi* faces greater threats from its small population size, which is highly susceptible to extinction from stochastic events. Of the two species, it is in far greater need of conservation actions. While the headwaters of the Conasauga River are afforded protection as National Forest, the reach occupied by *P. jenkinsi* is entirely on private property. Poor sediment management practices in this reach may negate any benefits of upstream protection measures. Conservation efforts should focus on cooperative efforts to protect riparian buffers, keep livestock out of stream channels, and eliminate erosional "hot spots" both in the Conasauga River and its tributaries. These proposals are similar to those instituted for other imperiled species (e.g. Kuhajda et al., 2009). Any captive propagation efforts for *P. jenkinsi* must be conducted carefully to preserve its unique genetic structure.

The use of a phylogenetic framework in evaluating conservation status also helps illuminate another biological attribute of "extinction-prone" species (Terborgh, 1974). While ecological traits that predispose species to imperilment have been well-studied (Angermeier, 1995; Griffis and Jaeger, 1998; Pyron, 1999), there has been less examination of evolutionary factors that may contribute to the health of species. Evolutionary factors that affect species may include basic attributes such as the level of genetic diversity and degree of differentiation among populations (George et al., 2006), rates of differentiation within the group, or the age of the taxon. Purvis et al. (2000) noted a strong effect of phylogenetic diversity and clade age on risk of extinction. Older and depauperate clades

were more likely to go extinct than more diverse clades or than expected by random chance. *Percina rex* and *P. jenkinsi* were recovered as the oldest species within the subgenus, and the next most basal member, *Percina burtoni*, is also considered vulnerable (Warren et al., 2000). Within the genus, *Percina macrocephala*, *Percina lenticula* Richards and Knapp, *Percina antesella*, and *Percina cymatotaenia* (Gilbert and Meek) are all considered threatened or endangered by Warren et al. (2000) and are also recovered as more basal species in their respective clades (Near, 2002). Knowledge of the evolutionary history of a taxon will not only aid in current management, but may also aid in identification of extinction-prone species.

ACKNOWLEDGEMENTS

We thank V.B. Salmikov and B.J. Freeman for assistance in the field collecting these individuals, and K. Leftwich for assistance in securing funding. We also thank C.B. Dillman, B.L. Fluker, N.J. Lang, J.M. Ray, J.B. Smith, and two anonymous reviewers for providing suggestions on the manuscript. This study was supported by U. S. Forest Service Grant CS1180100006. Specimens were collected under Federal Permit TEO42764-0, Tennessee permit number 713 and Virginia permit numbers 016122, 017806, 019603, 021444.

LITERATURE CITED

- Abell, R.A., D.M. Olsen, E. Dinerstein, P.T. Hurley, J.T. Diggs, W. Erichbaum, S. Walters, W. Wettengel, T. Allnutt, C.J. Loucks, and P. Hedao. 2000. Freshwater Ecoregions of North America. A Conservation Assessment. Island Press, Washington, D.C.
- Angermeier, P.L. 1995. Ecological attributes of extinction-prone species: Loss of freshwater fishes of Virginia. *Conservation Biology* 9:143–158.
- Bremer, K. 1994. Branch support and tree stability. *Cladistics* 10:295–304.
- Burkhead, N.M. 1983. Ecological studies of two potentially threatened fishes (the Orange-fin Madtom, *Noturus gilberti* and the Roanoke Logperch, *Percina rex*) endemic to the Roanoke River drainage. Final report to the Wilmington District, U.S. Army Corps of Engineers, Wilmington, NC. 115 pp.
- Burkhead, N.M., S.J. Walsh, B.J. Freeman, and J.D. Williams. 1997. Status and restoration of the Etowah River, an imperiled Southern Appalachian ecosystem. Pp. 375–441 *In*: G.W. Benz and D.E. Collins (eds.). *Aquatic Fauna in Peril: The Southeastern Perspective*. Lenz Design and Communications, Decatur, GA.
- Burr, B.M., and R.L. Mayden. 1992. Phylogenetics and North American freshwater fishes. Pp. 18–75 *In*: R.L. Mayden (ed.). *Systematics, Historical Ecology, and North American Freshwater Fishes*. Stanford University Press, Stanford, CA.
- Clement, M., D. Posada, and K.A. Crandall. 2000. TCS: A computer program to estimate gene genealogies. *Molecular Ecology* 9:1657–1659.
- Edwards, S.V., and P.W. Hedrick. 1998. Evolution and ecology of MHC molecules: from genomics to sexual selection. *Trends in Ecology and Evolution* 13:305–311.
- Etnier, D.A. 1997. Jeopardized southeastern freshwater fishes: A search for causes. Pp. 87–104 *In*: G.W. Benz and D.E. Collins (eds.). *Aquatic Fauna in Peril: The Southeastern Perspective*. Lenz Design and Communications, Decatur, GA.
- Etnier, D.A., and W.C. Starnes. 1991. An analysis of Tennessee's jeopardized fish taxa. *Journal of the Tennessee Academy of Science* 66:129–133.
- Etnier, D.A., and W.C. Starnes. 1993. *The Fishes of Tennessee*. University of Tennessee Press, Knoxville, TN.
- Excoffier, L., and H. E. L. Lischer. 2010. Arlequin suite ver 3.5: A new series of programs to perform population genetics analyses under Linux and Windows. *Molecular Ecology Resources* 10: 564–567.
- Farris, J.S., M. Källersjö, A.G. Kluge, and C. Bult. 1994. Testing significance of incongruence. *Cladistics* 10:315–319.
- Folkerts, G.W. 1997. State and fate of the world's aquatic fauna. Pp. 1–16 *In*: G.W. Benz and D.E. Collins (eds.). *Aquatic Fauna in Peril: The Southeastern Perspective*. Lenz Design and Communications, Decatur, GA.
- Franklin, I.R. 1980. Evolutionary change in small populations. Pp. 135–150 *In*: M.E. Soule and B.A. Wilcox (eds.). *Conservation Biology: An Evolutionary-Ecological Perspective*. Sinauer Associates, Sunderland, MA.
- Freeman, B.J., G.W. Benz, and D.E. Collins. 1996. A stakeholder's guide to the Conasauga River of Georgia and Tennessee. *Conservation Bulletin Number 1*, Southeast Aquatic Research Institute, Chattanooga, TN. 15 pp.
- Fu, Y.X., and W.H. Li. 1993. Statistical tests of neutrality of mutations. *Genetics* 133:693–709.
- George, A.L., D.A. Neely, and R.L. Mayden. 2006. Conservation genetics of an imperiled fish from eastern North America, the Blotchside Logperch, *Percina burtoni* (Teleostei: Percidae). *Copeia* 2006:585–594.
- Griffis, M.R., and R.G. Jaeger. 1998. Competition leads to an extinction-prone species of salamander: Interspecific territoriality in a metapopulation. *Ecology* 79:2494–2502.
- Hall T.A. 1999. BioEdit: a user-friendly biological sequence alignment editor and analysis program for Windows 95/98/NT. *Nucleic Acids Symposium Series* 41:95–98.
- Hanski, I. 1998. Metapopulation dynamics. *Nature* 396:41–49.
- Jenkins, R.E., and N.M. Burkhead. 1994. *Freshwater Fishes of Virginia*. American Fisheries Society, Bethesda, MD.
- Jordan, D.S. 1877. A partial synopsis of the fishes of upper Georgia. *Annals of the New York Lyceum of Natural History* 11:307–377.

- Jordan, D.S. 1889. Descriptions of fourteen species of fresh-water fishes collected by the U.S. Fish Commission in the summer of 1888. *Proceedings of the United States National Museum* 11:351–362.
- Kuhajda, B.R., A.L. George, and J. D. Williams. 2009. The desperate dozen: southeastern fishes on the brink. *Proceedings of the Southeastern Fishes Council* 51:10–30.
- Lang, N.J., and R.L. Mayden. 2007. Systematics of the subgenus *Oligocephalus* (Teleostei: Percidae: *Etheostoma*) with complete subgeneric sampling of the genus *Etheostoma*. *Molecular Phylogenetics and Evolution* 43:605–615.
- Lee, M.S.Y. 2001. Uninformative characters and apparent conflict between molecules and morphology. *Molecular Biology and Evolution* 18:676–680.
- Lydeard, C., and R.L. Mayden. 1995. A diverse and endangered aquatic ecosystem of the southeast United States. *Conservation Biology* 9:800–805.
- Master, L.L. 1990. The imperiled status of North American aquatic animals. *Biodiversity Network News* 3:1–2, 7–8.
- Mettee, M.F., P.E. O’Neil, and J.M. Pierson. 1996. *Fishes of Alabama and the Mobile Basin*. Oxmoor House, Birmingham, AL.
- Near, T.J. 2002. Phylogenetic relationships of *Percina* (Percidae: Etheostomatinae). *Copeia* 2002:1–14.
- Near, T.J., and M.F. Benard. 2004. Rapid allopatric speciation in logperch darters (Percidae: *Percina*). *Evolution* 58:2798–2808.
- Nei, M. 1987. *Molecular Evolutionary Genetics*. Columbia University Press, New York.
- Nei, M. and F. Tajima. 1981. DNA polymorphism detectable by restriction endonucleases. *Genetics* 97:145–163.
- Neves, R.J., A.E. Bogan, J.D. Williams, S.A. Ahlstedt, and P.W. Hartfield. 1997. Status of aquatic mollusks in the southeastern United States: a downward spiral of diversity. Pp. 43–85 *In*: G.W. Benz and D.E. Collins (eds.). *Aquatic Fauna in Peril: The Southeastern Perspective*. Lenz Design and Communications, Decatur, GA.
- Parmalee, P.W., and A.E. Bogan. 1998. *The Freshwater Mussels of Tennessee*. University of Tennessee Press, Knoxville, TN.
- Purvis, A., P.-M. Agapow, J.L. Gittleman, and G.M. Mace. 2000. Nonrandom extinction and the loss of evolutionary history. *Science* 288:328–330.
- Pyron, M. 1999. Relationships between geographical range size, body size, local abundance, and habitat breadth in North American suckers and sunfishes. *Journal of Biogeography* 26:549–558.
- Richter, B.D., D.P. Braun, M.A. Mendelson, and L.L. Master. 1997. Threats to imperiled freshwater fauna. *Conservation Biology* 11:1081–1093.
- Roberts, J.H., P.L. Angermeier, and E.M. Hallerman. 2009. Analysis of population genetics of Roanoke logperch (*Percina rex*) based on microsatellite markers. Final Report to the U.S. Fish and Wildlife Service, Gloucester, VA. 35 pp.
- Rosenberger, A.E. 2007. An update to the Roanoke logperch recovery plan. Final Report to the U.S. Fish and Wildlife Service, Gloucester, VA. 51 pp.
- Rosenberger, A.E., and P.L. Angermeier. 2003. Ontogenetic shifts in habitat use by the endangered Roanoke logperch (*Percina rex*). *Freshwater Biology* 48:1563–1577.
- Rozas, J., J.C. Sánchez-DelBarrio, X. Messeguer, and R. Rozas. 2003. DnaSP, DNA polymorphism analyses by the coalescent and other methods. *Bioinformatics* 19:2496–2497.
- Sloss, B.L., N. Billington, and B.M. Burr. 2004. A molecular phylogeny of the Percidae (Teleostei, Perciformes) based on mitochondrial DNA sequence. *Molecular Phylogenetics and Evolution* 32:545–562.
- Song, C.B., T.J. Near, and L.M. Page. 1998. Phylogenetic relations among percid fishes as inferred from mitochondrial cytochrome *b* DNA sequence data. *Molecular Phylogenetics and Evolution* 10:343–353.
- Swofford, D.L. 2002. PAUP*: Phylogenetic Analysis Using Parsimony (*and other methods), version 4, 4.0b10. Sinauer Associates, Sunderland, MA.
- Tajima, F. 1989. Statistical method for testing the neutral mutation hypothesis by DNA polymorphism. *Genetics* 123:585–595.
- Terborgh, J. 1974. Preservation of natural diversity: The problem of extinction prone species. *BioScience* 24:715–722.
- Thompson, B.A. 1985. *Percina jenkinsi*, a new species of logperch (Pisces, Percidae) from the Conasauga River, Tennessee and Georgia. *Occasional Papers of the Louisiana State Museum of Zoology* 61:1–23.
- U.S. Fish and Wildlife Service. 1985. Determination of endangered status and of critical habitat for the amber darter and the Conasauga logperch. *Federal Register* 50:31597–31604.
- U.S. Fish and Wildlife Service. 1989. Endangered and threatened wildlife and plants; endangered status for the Roanoke logperch. *Federal Register* 54:34468–34472.
- Warren, M.L., B.M. Burr, S.J. Walsh, H.L. Bart, R.C. Cashner, D.A. Etnier, B.J. Freeman, B.R. Kuhajda, R.L. Mayden, H.W. Robison, S.T. Ross, and W.C. Starnes. 2000. Diversity, distribution, and conservation status of the native freshwater fishes of the southern United States. *Fisheries* 25:7–29.

Table 1. Collection data for specimens of *Percina rex* and *Percina jenkinsi* used in genetic analyses. Tissues are accessioned at the University of Alabama Ichthyological Collection (UAIC), or at the Saint Louis University Museum (STL). The haplotype column corresponds to Figures 3 and 4, with the number of individuals with that haplotype in parentheses.

Site Number	Locality	Population	Accession No.	Number	Haplotypes
<i>Percina rex</i>					
1	N. Fk. Roanoke River, Montgomery Co., VA	Roanoke	UAIC 13539.01	2	B (1) C (1)
2	S. Fk. Roanoke River, Montgomery Co., VA	Roanoke	UAIC 13538.01	4	A (1) B (1) D (1) I (1)
3	Roanoke River, Montgomery Co., VA	Roanoke	UAIC 7932.15	1	H (1)
3	Roanoke River, Montgomery Co., VA	Roanoke	UAIC 13465.01	3	E (1) F (1) G (1)
4	Big Chestnut Creek, Franklin Co., VA	Pigg	UAIC 13540.01	5	J (5)
5	Smith River, Patrick Co., VA	Smith	UAIC 13466.01	3	F (1) I (1) L (1)
6	Town Creek, Henry Co., VA	Smith	UAIC 13467.01	7	F (1) K (6)
7	Stony Creek, Dinwiddie Co., VA	Chowan	UAIC 13468.01	1	M (1)
8	Stony Creek, Dinwiddie Co., VA	Chowan	UAIC 13541.01	3	M (2) N (1)
<i>Percina jenkinsi</i>					
1	Conasauga River, Polk Co., TN	Conasauga	UAIC 13464.09	1	C (1)
2	Conasauga River, Polk Co., TN	Conasauga	STL 1008.01	1	B (1)
3	Conasauga River, Polk Co., TN	Conasauga	UAIC 13489.06	2	A (1) D (1)
3	Conasauga River, Polk Co., TN	Conasauga	STL 1009.01	1	E (1)
4	Conasauga River, Murray Co., GA	Conasauga	STL 1010.01	1	A (1)
5	Conasauga River, Murray Co., GA	Conasauga	STL 1011.01	1	A (1)
6	Conasauga River, Murray Co., GA	Conasauga	STL 1012.01	1	C (1)
6	Conasauga River, Murray Co., GA	Conasauga	UAIC 11680.01	1	F (1)

Table 2. Diversity indexes for *Percina rex* and *P. jenkinsi* cytochrome *b* and ND2 sequences used in this study. Number of individuals (N), number of haplotypes (Hn), haplotype diversity (Hd), and nucleotide diversity (π).

Species/Population	N	Hn	Hd	π
<i>Percina rex</i>				
Roanoke River	10	9	0.978	0.0020
Pigg River	5	1	0.000	0.0000
Smith River	10	4	0.644	0.0031
Chowan River	4	2	0.500	0.0005
Total	29	15	0.919	0.00367
<i>Percina jenkinsi</i>				
Conasauga River	9	6	0.889	0.00485

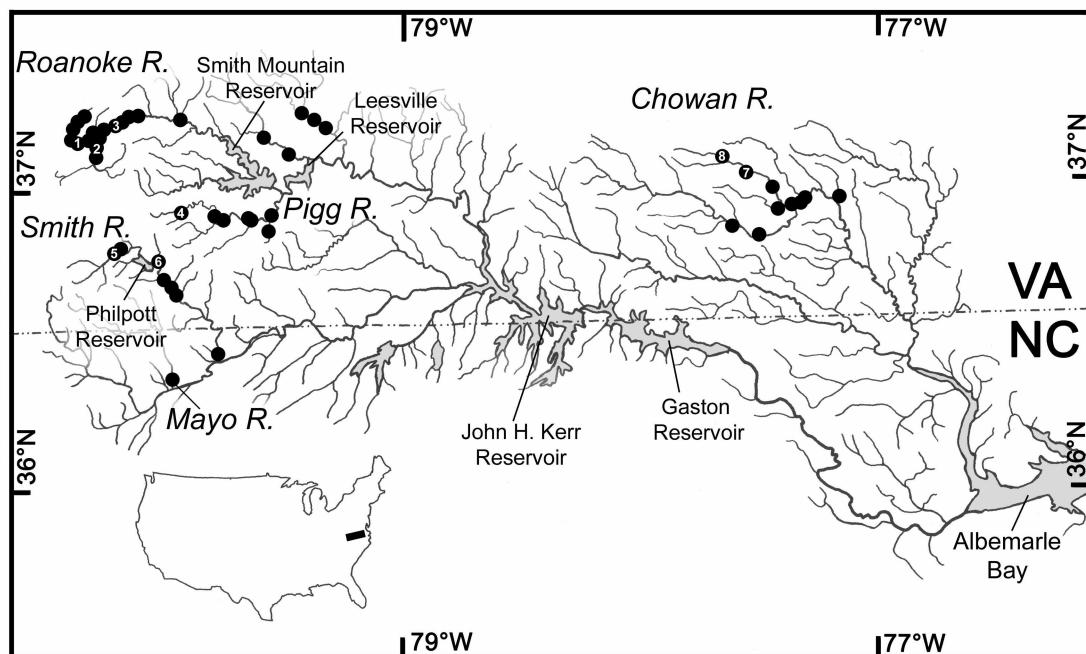

FIGURE 1. Distribution of *Percina rex* in the Roanoke and Chowan river drainages. Black dots with numbers correspond to those listed in Table 1. Solid dots represent additional extant localities.

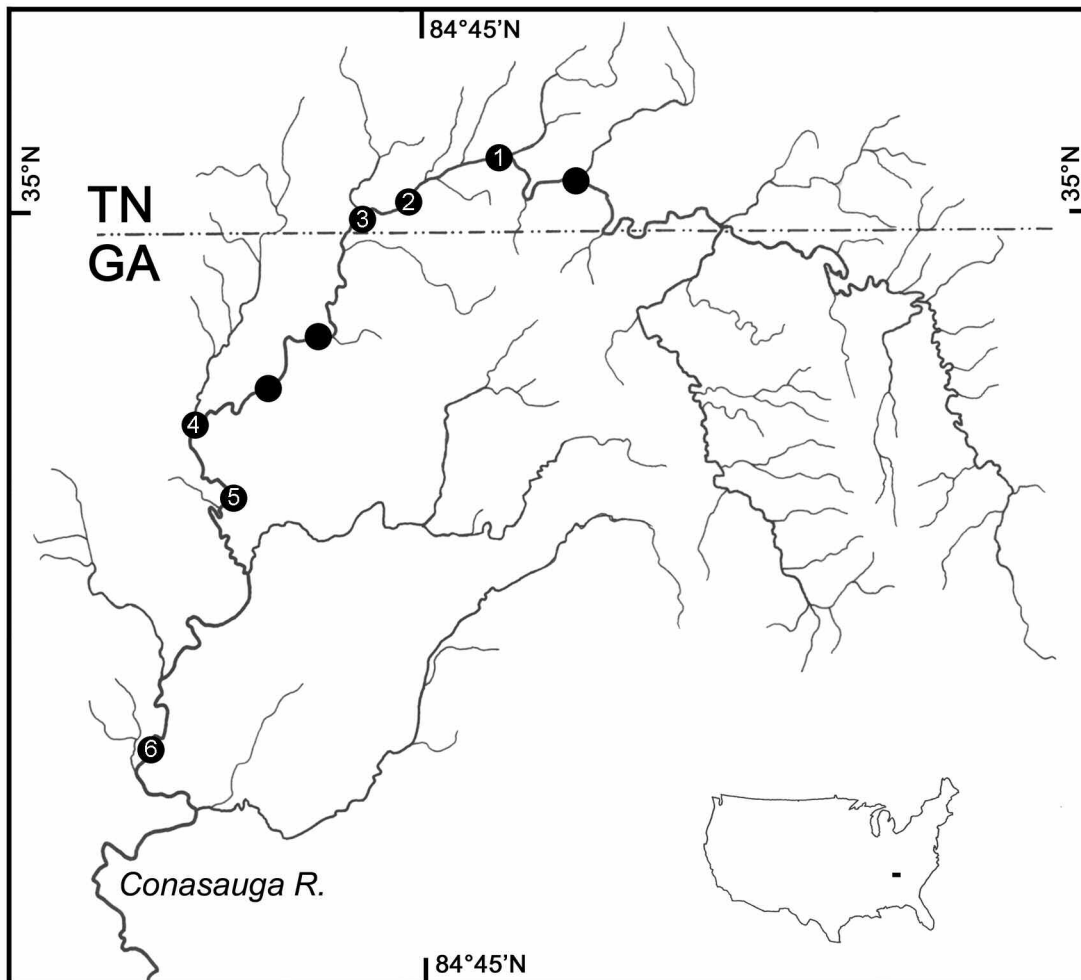

FIGURE 2. Distribution of *Percina jenkinsi* in the Conasauga River system. Black dots with numbers correspond to those listed in Table 1. Solid dots represent additional extant localities.

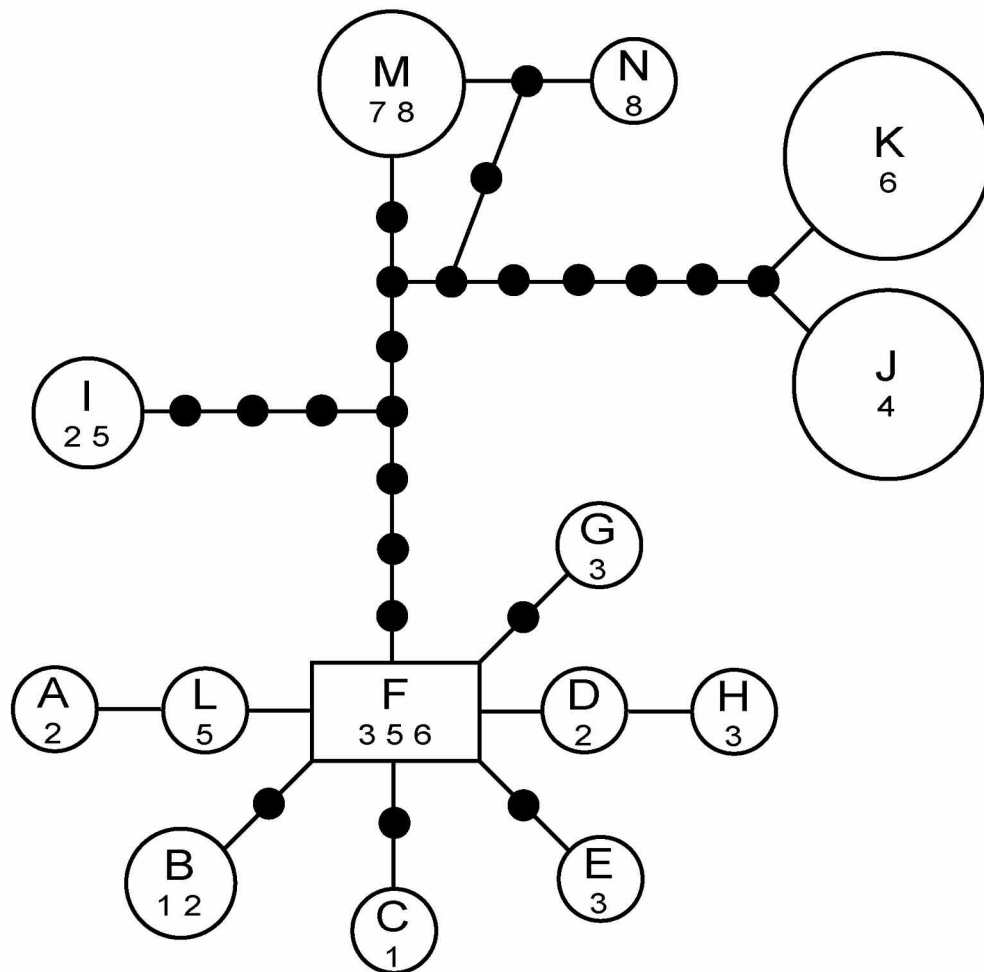

FIGURE 3. Haplotype network for *Percina rex* representing 14 haplotypes from 29 individuals within the Roanoke and Chowan river drainages. Circle size reflects the frequency of haplotypes, solid lines represent one mutational event and small black circles represent theoretical haplotypes. Haplotype letters correspond with those listed in Table 1. Numbers below the haplotypes represent site numbers as listed in Table 1. The ancestral haplotype, F, is denoted by a square.

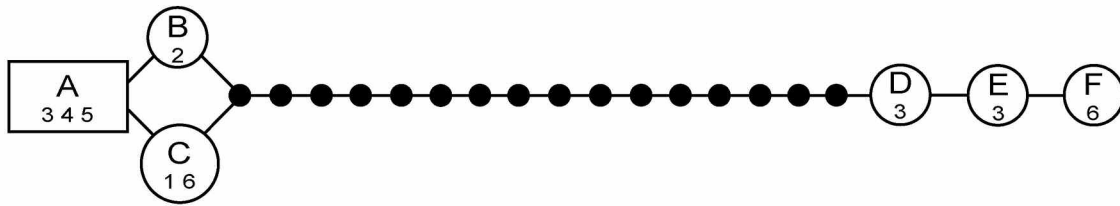

FIGURE 4. Haplotype network for *Percina jenkinsi* representing 6 haplotypes from 9 individuals within the Conasauga River. Circle size reflects the frequency of haplotypes, solid lines represent one mutational event and small black circles represent theoretical haplotypes. Haplotype letters correspond with those listed in Table 1. Numbers below the haplotypes represent site numbers as listed in Table 1. The ancestral haplotype, A, is denoted by a square.

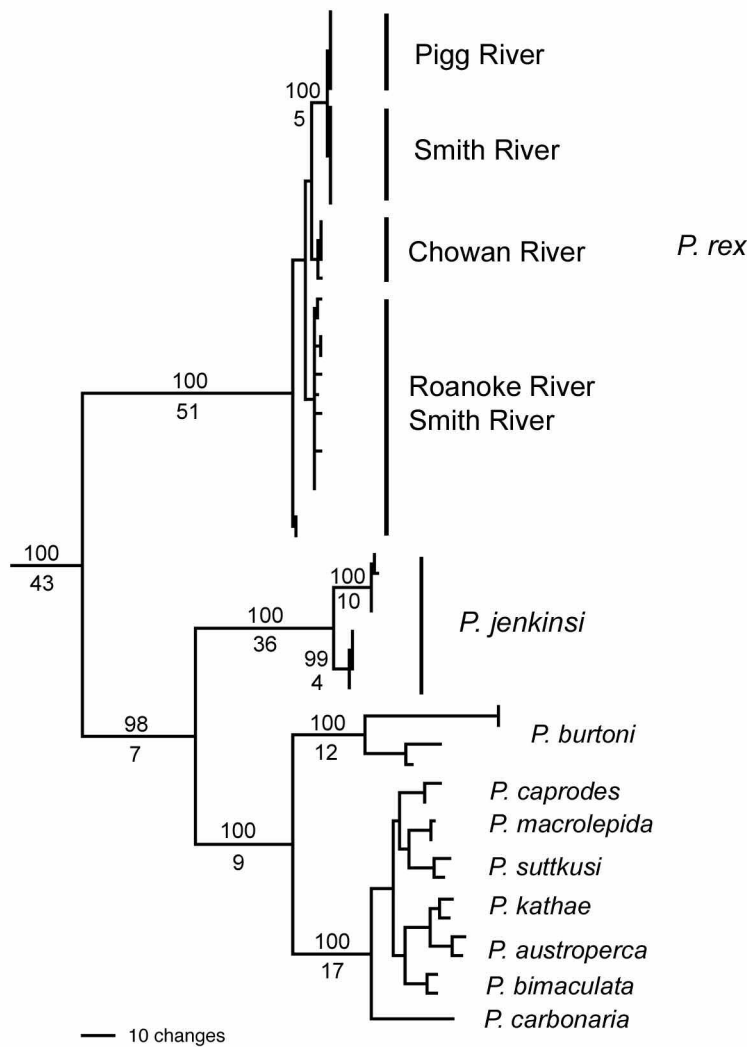

FIGURE 5. Phylogram representing one of nine topologies recovered by parsimony analysis of combined *cyt b* and ND2 datasets for the subgenus *Percina*. Jackknife support values of greater than 80% are shown above branches, and Bremer decay values greater than two are shown below branches for the basal nodes and within *P. rex* and *P. jenkinsi*.

Invasion of Gulf Menhaden in the Alabama River

T. HEATH HALEY, R. KYLE BOLTON, AND CAROL E. JOHNSTON*

Fish Biodiversity Lab, Department of Fisheries,
Auburn University, Auburn, AL 36849

*Corresponding author: johnsc5@auburn.edu

ABSTRACT

Our recent survey of the Alabama River (river miles 22.9 – 72) for fishes has revealed the presence of Gulf Menhaden in extremely large numbers throughout the study area. Historical records of this marine species are confined to coastal areas. Typically this species migrates to open Gulf waters in the winter and spring for spawning. Our samples suggest that large numbers of young adult Gulf Menhaden migrated up the Alabama River instead, where we found them in both summer and fall samples. We also collected Gulf Menhaden during day and night samples on sand/gravel bars. The presence of larval individuals in our samples suggests that spawning may have occurred in the river. The presence of this planktivorous fish in such large numbers has the potential to profoundly affect the aquatic ecosystem of the Alabama River, and needs to be monitored.

INTRODUCTION

Gulf Menhaden (*Brevoortia patronus* Goode), is a marine species common to the central Gulf of Mexico (Hoesel and Moore, 1977; McEachran and Fechhelm, 1998). The species forms large schools near the surface that support purse seine fisheries throughout the Gulf of Mexico. The Gulf Menhaden fishery is one of the largest by weight and most valuable in the United States (Christmas et al., 1982; Ross, 2001; Vaughan et al., 2000). This commercially important species is tolerant of a wide range of salinities, and can be found from offshore areas of the Gulf of Mexico to the lower reaches of major Gulf drainages, including the Tombigbee and Tensaw Delta (Lassuy, 1983; Mettee et al., 1996; Ross, 2001; Boschung and Mayden, 2004). Typically, spawning takes place in open waters of the Gulf in fall and spring (Ahrenholz, 1991). After hatching from pelagic eggs, larvae are carried to inshore marshes via currents. Juveniles spend a variable amount of time in estuarine habitat before migrating offshore (Lassuy, 1983; Ahrenholz, 1991). Menhaden selectively predate on zooplankton and phytoplankton as larvae, and then transition to non-selective filter feeders as adults (Ross, 2001).

Although many marine species are commonly found in the Alabama River as far upstream as Claiborne Lock and Dam (eg., Hogchocker, *Trinectes maculatus* (Bloch and Schneider); Southern Flounder, *Paralichthys lethostigma* Jordan and Gilbert; Striped Mullet, *Mugil cephalus* Linnaeus; Atlantic Needlefish, *Strongylura marina* (Walbaum); Boschung and Mayden, 2004), this is the first record of Gulf Menhaden in this portion of the Alabama River. Our objective is to report the numbers of individuals and collection localities of Gulf Menhaden collected in the Alabama River during a 2010 survey.

MATERIALS AND METHODS

Nineteen sand/ gravel bars were sampled from river mile 22.9 – 72 during June-August and October 2010 (Fig. 1; Appendix). Fishes were collected on these habitats using 30, 15, and 9 m seines (5-10 efforts per site). The length of each haul was dictated by depth of the reach and presence of obstructions, but generally ranged between 30 - 100 m. Selected sites were re-sampled at night and during the fall to document diurnal and seasonal assemblage changes (41 samples total). Species that were easily identified and those of conservation concern were returned to the river. Others were preserved and taken back to the lab for identification. These specimens were anesthetized in MS 222 (tricaine methanesulfonate) and preserved in a 10% formalin solution.

Due to the extremely high numbers of Gulf Menhaden collected, subsampling was used to approximate total numbers per haul. In these circumstances Gulf Menhaden were distributed evenly in a square and divided into proportionate fractions until a reasonable subsample could be counted. Subsamples ranged from 1/4 to 1/64 of the total catch. Standard length (SL) of preserved specimens was measured in millimeters (mm) to assess age structure.

RESULTS AND DISCUSSION

Gulf Menhaden were collected at 12 of 19 sites during our survey (Table 1). The species was absent from the lowermost sample sites of our survey (Fig. 1; Table 1).

Numbers of individuals ranged from 1 to over 144,000 and was greater during the fall sample, likely related to lower water levels. Gulf Menhaden were also present in night samples (Table 1).

Lengths of Gulf Menhaden suggest that two age classes were present in the summer samples. While most individuals were age 0 (mean = 54 mm SL, n = 94), larval specimens were also collected in summer samples (mean = 21 mm SL, n = 13). These lengths fall into year classes described by Lassuy (1983). While the age 0 class also dominated fall samples, larger individuals (90-100 mm SL) were present in small numbers (n = 10). These larger individuals either grew to this size class over this summer or were missed in earlier samples.

The presence of extremely large numbers of Gulf Menhaden upstream to river mile 72 in the Alabama River is clearly a rare occurrence. It is possible that inshore movement was a result of some stimulus in their typical marine habitat. Although the timing and length of use of marsh habitat is labile for this species, certainly by fall these individuals should have migrated offshore for spawning (Fore and Baxter, 1972). The presence of very small individuals may be an indication that Gulf Menhaden spawned in the Alabama River. By 21 mm SL, individuals ordinarily move into marsh habitat using offshore currents (Christmas et al., 1982; Ross, 2001; Vaughan et al. 2000).

Predicting the impact of such large numbers of planktivorous fish on the ecosystem of the Alabama River is difficult, and should be the topic of future work. Of special concern is their impact on other filter feeding fishes, including Alabama Shad. If large numbers of this species persist in the river, there will undoubtedly be an impact on the existing food web. Our future work is aimed at monitoring the potential migration, abundance, and distribution of Gulf Menhaden in the Alabama River, as well as monitoring the entire fish assemblage.

ACKNOWLEDGMENTS

We would like to thank Steve Rider, Travis Powell, Jeff Powell, Kasie Goodsen and Katelyn Dowling for field assistance. This project was funded by the USFWS.

LITERATURE CITED

- Ahrenholz, D. W. 1991. Population biology and life history of the North American menhadens, *Brevoortia* spp. *Marine Fisheries Review* 53:3-19.
- Boschung, H.T., and R.L. Mayden. 2004. *Fishes of Alabama*. Smithsonian Books, Washington D.C. 736 pp.
- Christmas, J.Y., J.T. McBee, R. S. Waller, and F.C. Sutter, III. 1982. Habitat suitability index models: Gulf Menhaden. U.S. Department of Interior, Fish and Wildlife Service. FWS/OBS-82/10.23. 23 pp.
- Fore, P.L., and K.N. Baxter. 1972. Diel fluctuations in the catch of larval Gulf Menhaden, *Brevoortia patronus*, at Galveston Entrance, Texas. *Transactions of the American Fisheries Society* 101:729-732.
- Hoese, H.D., and R.H. Moore. 1977. *Fishes of the Gulf of Mexico, Texas, Louisiana, and Adjacent Waters*. W.L. Moody, Jr. Natural History Series; No.1. Texas A&M University Press. College Station, TX. 327 pp.
- Lassuy, D.R. 1983. Species profiles: life histories and environmental requirements (Gulf of Mexico): Gulf Menhaden. U.S. Fish and Wildlife Service, Division of Biological Services, FWS/OBS-82/11. U.S. Army Corps of Engineers, TR EL-82-4. 13 pp.
- McEachran, J.D., and J.D. Fechhelm. 1998. *Fishes of the Gulf of Mexico, Vol 1*. University of Texas Press. Austin, TX. 1112 pp.
- Mettee, M.F., P.E. O'Neil, and J.M. Pierson. 1996. *Fishes of Alabama and the Mobile Basin*. Oxmoor House, Inc. Birmingham, AL. 820 pp.
- Ross, S.T. 2001. *Inland Fishes of Mississippi*. University Press of Mississippi. Jackson, MS. 624 pp.
- Vaughan, D.S., J.W. Smith, and M.H. Prager. 2000. Population characteristics of Gulf Menhaden, *Brevoortia patronus*. NOAA Technical Report NMFS 149. U.S. Department of Commerce. Seattle, WA. 19 pp.

TABLE 1. Number of Gulf Menhaden collected in sand/gravel bar samples in the Alabama River in 2010. Site numbers correspond to locality data in the Appendix and to the map (Fig. 1).

Site #	Number of individuals			
	Summer		Fall	
	Day	Night	Day	Night
1	5,649	8,159	18,590	493
2	8	-	-	-
3	1	-	-	-
4	4	1	144,464	29,776
5	0	-	109,052	-
6	1	-	-	-
7	1,200	-	-	-
8	321	0	0	-
9	12,279	0	420	71
10	0	0	0	36
11	14	-	14,067	-
12	0	-	690	-
13	808	-	2,472	-
14	29,195	-	-	-
15	8,520	-	-	-
16	2,616	-	-	-
17	0	-	-	-
18	0	-	-	-
19	0	-	-	-

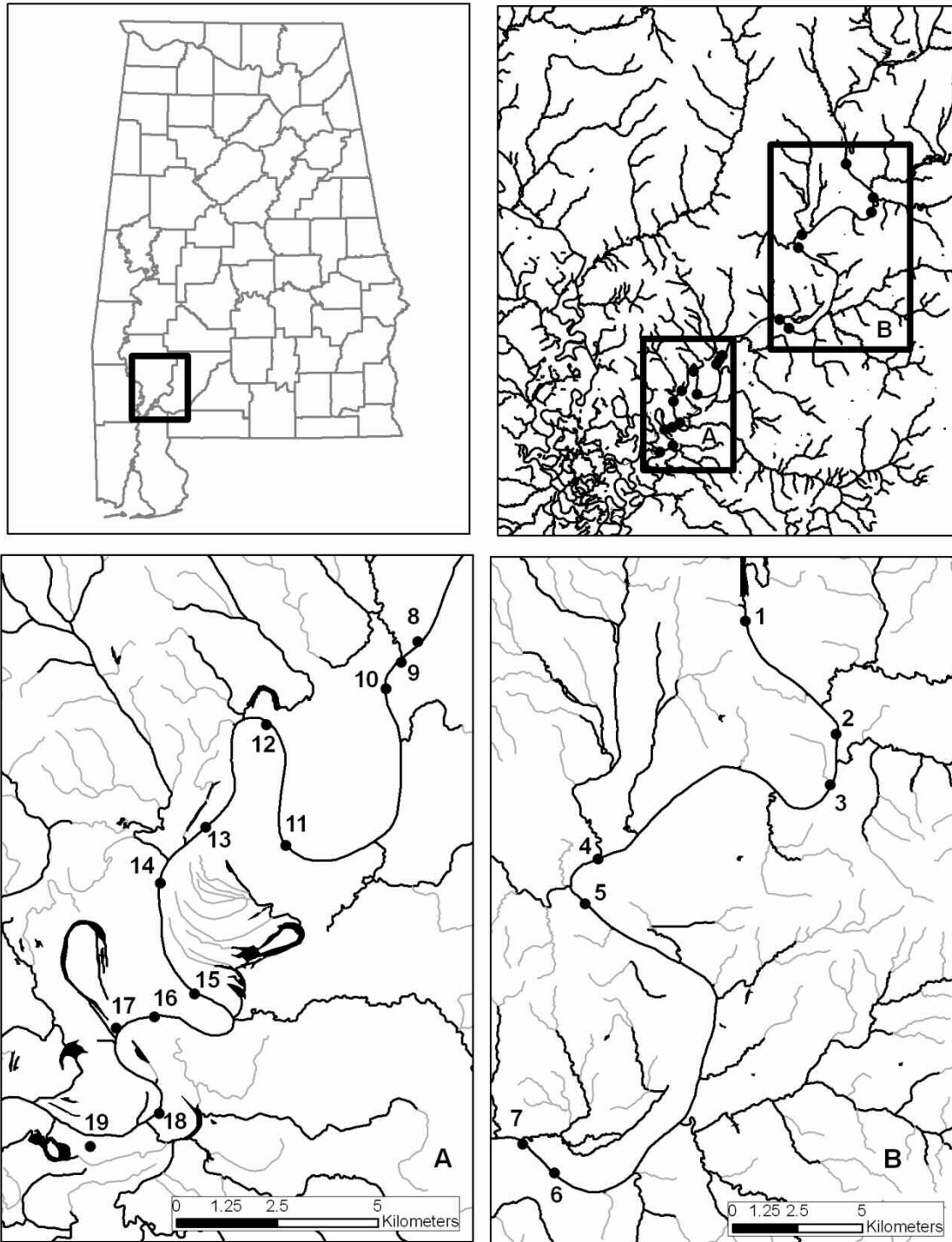

FIGURE 1. Collection sites in the Alabama River, Alabama. Site numbers correspond to locality data in the Appendix.

Appendix. Sites sampled in the Alabama River.

Site	Latitude	Longitude	AI River Mile	Site Description	Date
1	31.606766	87.550967	72	Sandbar directly below Claiborne Dam	6/28/10
1a	31.608425	87.551257	72.1	Sandbar directly below Claiborne Dam	7/8/10
1b	31.607965	87.551087	72	Sandbar directly below Claiborne Dam	7/27/10
1c	31.607564	87.550947	72	Sandbar directly below Claiborne Dam	10/14/10
1d	31.608583	87.550989	72	Sandbar directly below Claiborne Dam	10/15/10
2	31.567631	87.513743	68.3	Sandbar downriver of paper plant	6/28/10
2a	31.567598	87.513762	68.3	Sandbar downriver of paper plant	7/8/10
3	31.549879	87.516141	66.9	Directly above Hwy 84 bridge	7/8/10
3a	31.547998	87.517645	66.7	Directly below Hwy 84 bridge, small sand bar between jetties	7/8/10
4	31.523702	87.610241	60	3 pile Jetty's gravel bar near Nancy Hill Landing across from Pigeon Creek	7/8/10
4a	31.523725	87.610925	60	3 pile Jetty's gravel bar near Nancy Hill Landing across from Pigeon Creek	8/2/10
4b	31.523681	87.610989	60	3 pile Jetty's gravel bar near Nancy Hill Landing across from Pigeon Creek	10/14/10
4c	31.523841	87.610255	60	3 pile Jetty's gravel bar near Nancy Hill Landing across from Pigeon Creek	10/15/10
5	31.508194	87.615469	58.3	Mrs. Grey's Bar right bank (downriver)	7/8/10
5a	31.50848	87.615571	58.3	Mrs. Grey's Bar right bank (downriver)	10/14/10
6	31.414326	87.627276	47	Sandbar divided by jetties between Shackleford Bar and English Landing	7/26/10
6a	31.416228	87.630366	47	Sandbar divided by jetties between Shackleford Bar and English Landing	7/26/110
7	31.424393	87.640235	46.4	Sandbar / Disposal area between Frenchs Landing and English Landing	7/26/10
8	31.382167	87.717499	40.3	Sandbar across and downriver from Euryka Landing (near Irvin Creek)	7/9/10
9	31.377482	87.721757	39.6	Sandbar near Irvin Creek (Directly above mouth of creek)	7/26/110

Appendix, cont.

9a	31.380454	87.718138	39.6	Sandbar near Irvin Creek (Directly above mouth of creek)	8/9/10
9b	31.380648	87.717944	39.6	Sandbar near Irvin Creek (Directly above mouth of creek)	8/10/10
9c	31.379762	87.718719	39.6	Sandbar near Irvin Creek (Directly above mouth of creek)	10/15/10
9d	31.379856	87.718624	39.6	Sandbar near Irvin Creek (Directly above mouth of creek)	10/16/10
10	31.371523	87.725739	39.3	Sandbar downriver and opposite of Irvin Creek	7/9/10
10a	31.369525	87.726053	39.2	Sandbar downriver and opposite of Irvin Creek	8/10/10
10b	31.369839	87.7261	39.2	Sandbar downriver and opposite of Irvin Creek	8/10/10
10c	31.370694	87.726122	39.2	Sandbar downriver and opposite of Irvin Creek	10/15/10
10d	31.370718	87.726146	39.2	Sandbar downriver and opposite of Irvin Creek	10/16/10
11	31.336299	87.75164	35.4	Sandbar above (upriver) Choctaw Bluff	7/9/10
11a	31.336819	87.752356	35.4	Sandbar above (upriver) Choctaw Bluff	10/15/10
12	31.363272	87.756877	33.3	Sandbar across Choctaw Bluff (east bank)	7/9/10
12a	31.363176	87.755872	33.3	Sandbar across Choctaw Bluff (east bank)	10/16/10
13	31.340333	87.772578	31.6	Sandbar (Island) \approx 1.3mi below Choctaw Bluff	7/27/10
13a	31.3396	87.77209	31.6	Sandbar (Island) \approx 1.3mi below Choctaw Bluff	10/16/10
14	31.327761	87.784254	29.9	Sandbar 0.8mi down from Matthewsons Bar	7/27/10
15	31.303009	87.775094	28.4	Sandbar upriver of Dixie Landing	7/27/10
16	31.297774	87.785475	26.3	Sandbar near Dixie Cutoff and Monroe Point	7/27/10
17	31.295258	87.795414	25.5	Sandbar Below Monroe Point	8/2/10
18	31.276208	87.78405	24	Alabama River Sandbar	8/2/10
19	31.26872	87.802023	22.9	Sandbar @ Earl Bar	8/2/10

STATE REPORTS

ALABAMA

Steve Rider (Alabama Division of Wildlife and Freshwater Fisheries) reports that during the second year of their Stream Assessment Project (part of a multi-year effort by Alabama Department of Conservation and Natural Resources (ADCNR), Geological Survey of Alabama (GSA), and Alabama Department of Environmental Management (ADEM)), 60 stream sites were sampled in the Tennessee, Black Warrior, Cahaba, Coosa, Tallapoosa, Chattahoochee, Yellow, Pea, Mobile, and Choctawhatchee river drainages. Of particular interest were the collection of Blotched Chub in Cypress Creek, Tennessee drainage, and Largescale Spinycheek Sleeper in Palmetto Creek, a direct tributary to Perdido Bay. Coal Darters were collected in relative abundance at several sites in Locust Fork of the Black Warrior, the Cahaba River, and Hatchet Creek.

Alabama Shad assessment continued in 2010 in the Conecuh River, resulting in the capture of a single adult and no juveniles. Bycatch included two YOY Gulf Sturgeon, one in June and one in July, measuring 81 and 149 mm TL, respectively.

Sampling continued for the undescribed Southern Walleye, with only six fish collected in 2010. In Alabama, Southern Walleye are now only collected in Hatchet Creek, which drains into Lake Mitchell (Coosa River). A cooperative agreement was entered into between the ADWFF, Mississippi Department of Wildlife, Fisheries, and Parks, and U.S. Fish and Wildlife Service (USFWS) for the conservation and restoration of native walleye in the Mobile River Basin. Southern Walleye males from Hatchet Creek will be used to improve the genetic integrity of existing broodstocks, in exchange for fingerlings to stock in Alabama. In cooperation with Rex Strange of the University of Southern Indiana, all walleye collected will be genetically tested to assure their origin before integration into any broodstock establishment or restoration effort.

Carol Johnston (Auburn University, Fish Biodiversity Lab) reports that they are completing a survey of fishes in the Alabama River this fall. Heath Haley's MS research assesses assemblage change over time, investigates day/night habitat use patterns, and compares assemblages of recent and historical dredge sites. Katie Dowling's MS work is aimed at investigating the role of water availability on fish assemblage change in the Chattahoochee drainage, particularly the role that spawning strategy plays in differential recruitment during high and low water years.

Doctoral students Patty Speares and Dan Holt continue to work on aspects of hearing, sound production, and

ambient noise in fishes and their environment. They have completed a study of the nesting ecology of three species of *Catnotus* darters, which includes an evaluation of their acoustic signals in the field and lab. They were able to record in-cavity behaviors and sounds by using a small video camera and hydrophone. They have also completed a study investigating the response of ostariophysan fishes to the high frequency sounds of disturbed gravel in the field. This study has implications for the evolution of sensitive hearing (to low amplitude as well as high frequencies) in these fishes, as it may be used for feeding cues and not predator detection, which is the currently accepted hypothesis. With assistance from Ryan Earley (University of Alabama) and Mary Mendonça (Auburn University), Patty is finishing experiments looking at hormonal responses to acoustic signals using the Fringed Darter as a model. They are also looking at microgeographic variation in acoustic signals of *Catnotus*, as well as signal evolution in this group. Dan continues to look at the effect of anthropogenic and environmental noise on nest site selection, amplitude of acoustic signals and behavioral variables in *Cyprinella*.

Pat O'Neil (Geological Survey of Alabama) has several new fish distribution records and surveys to report. Rediscovery of the Trispot Darter in Alabama in 2008 led to survey work in the Coosa River system in 2009-10, which yielded 354 individuals. Several breeding sites were found in the upper Big Canoe Creek system (Little Canoe Creek) and a new breeding site was found in the Ballplay Creek system. Additional work in 2010-11 will survey tributaries around Weiss Reservoir. Collections in the Locust Fork system during 2010 as part of the USFWS Strategic Habitat Unit (SHU) effort in Alabama yielded 362 individuals of the endangered Cahaba Shiner at several sites in the Locust Fork main channel. As part of the Statewide Cooperative IBI project several sites in the Cahaba River were sampled this year with 118 Cahaba Shiners found at the Riverbend site and 26 Goldline Darters found at three Cahaba River main channel sites. Two of the Goldline Darters were found at Bains Bridge, directly behind the very urbanized Galleria area in Hoover, Alabama, and represents a new upstream record. While assisting in a survey of the Paint Rock River system with the USFWS, Alabama Department of Conservation and Natural Resources, and The Nature Conservancy, 21 Snail Darters were collected at a main channel site near the community of Paint Rock. This extends the known range of the snail darter upstream 22.7 km from the last known location. The endangered Palezone Shiner was found to be doing well in Hurricane

Creek and Estill Fork, and several new state records for the Blotchside Logperch were found in the upper Paint Rock system. The GSA continued work with USFWS in the North River and Big Canoe Creek SHUs and will begin work in the future in the Terrapin Creek and the Sipsey River (Tombigbee) SHUs. SHU projects are cooperative stakeholder groups that are working to recover and restore watersheds that are home to rare aquatic species. GSA completed a survey of the Bear Creek system for fish species of greatest conservation need in Alabama, a report on the second of five Index of Biotic Integrity (IBI) studies calibrating this tool to streams of Alabama, and will complete a three-year survey of Alabama crayfishes along with colleagues Chris Taylor and Guenter Schuster.

Mark Meade (Jacksonville State University) reports that they are working with the National Park Service to survey the Blue Shiner population in Little River, They are also conducting genetic assessment of Holiday Darter populations in Shoal Creek, fish survey work in Choccolocco Creek, examining the use of hormone injections for propagation work, and studying the impact of mercury pollution on stream fishes.

Ryan Earley's Fish Behavior and Endocrinology Lab (The University of Alabama) is investigating the cues used by Bluenose Shiners to locate the nests of Longear Sunfish. There is evidence that the shiner deposits its eggs into the nests of the sunfish, and that the sunfish provides (perhaps inadvertently) care for the shiner offspring. Adam Fuller (Ph.D. student) dedicated this past year to capturing Bluenose Shiners, currently maintained in the laboratory in large stock tanks. Beginning in the early spring, they will initiate field-based experiments that will expose the shiners to various cues (e.g., combinations of nest, sunfish, and olfactory cues) related to longear sunfish presence to determine their behavioral response. They will also initiate controlled laboratory experiments to determine whether male and female shiners exhibit preferences for sunfish with certain traits that might be indicative of a high quality surrogate parent. Lastly, they are beginning to place this sunfish-shiner system in a phylogenetic context towards the end of exploring the origins and functions of the elaborate ornamentation (e.g., large fins and striking color) that male Bluenose Shiners express.

Graduate students in other labs at the University of Alabama are examining relationships and population genetics of imperiled fishes with sequence and microsatellite data, including Coal Darter (Heath Howell), Spring Pygmy Sunfish (Mike Sandel), and darters associated with springs and spring seeps (Slackwater, Coldwater, Rush, Tuscumbia, and Trispot darters; Brook Flucker). Mike Sandel is continuing to monitor Spring Pygmy Sunfish populations in Beaverdam Creek (Tennessee River drainage) and the impacts of sewer line construction; the populations

are in decline. Heath Howell is continuing his surveys of Shades Creek (Cahaba River) fishes, including the endangered Cahaba Shiner and threatened Goldline Darter, above and below rail cars once used as a road bed. These rail cars are scheduled for removal this fall and Heath will monitor the fish community for any changes after removal. Heath is also monitoring stream fishes in Turkey Creek, including the endangered Vermilion and Rush darters, above and below an old mill dam scheduled for removal next fall. Brook Flucker has started to examine the effects of a reservoir on the population genetics of stream fishes, using Tallapoosa Shiner and Tallapoosa Darter as his target species from streams entering the reservoir and tributaries of the flowing Tallapoosa River as a control; this project is being funded by WWF. Another graduate student, Nathan Whelan, is continuing a systematic revision of the freshwater snail genus *Leptoxis*. He is also working at the Alabama Aquatic Biodiversity Center to characterize the life history strategies of each *Leptoxis* species.

Jeff Ray (University of North Alabama) reports that Weed Shiners were collected from Cypress Creek by personnel from University of North Alabama, TVA, GSA and Alabama DCNR in Spring 2010. These represent the upstream-most records for the species in the Tennessee River system. This Tennessee-Tombigbee Waterway transplant has been present at downstream localities since at least 1990, but may now be spreading further upstream. A study to document additional populations in tributaries above Cypress Creek and determine the species' influence on fish community composition is ongoing. Any records of this species from the Tennessee River system not in museum holdings would be of interest, please contact Jeff Ray (jrray1@una.edu).

Daniel Drennan (US Fish and Wildlife Service) reports that the Jackson, MS office has completed the following: critical habitat of the Vermilion Darter in Pinson, Jefferson Co., Alabama (currently at the Washington Level of Review), proposed listing designation of the Rush Darter in Jefferson, Winston, and Etowah counties, as endangered: critical habitat to be proposed (at Regional Office level of review), 90 Day Finding for the Spring Pygmy Sunfish in Limestone Co. (at Regional Office level of review), and Flattened Musk Turtle Five Year Review in Winston, Jefferson, Walker, Fayette, Tuscaloosa, Cullman counties, (at Regional Office level of review).—*Bernie Kuhajda*

ARKANSAS

Henry W. Robison, Bob Cashner, Tom Near, and Morgan Raley are in the process of describing the Ouachita Darter (*Percina* sp. cf. *nasuta*), an endemic percid species of the Ouachita River drainage formerly considered to be Longnose Darter. The description will be published in the Bulletin of the Peabody Museum of Natural History.

Keith Crandall (BYU) and Robison continue to collect crayfishes for an eventual treatment of the *Crayfishes of Arkansas*.

Robison and Tom Buchanan continue to work toward completing the second edition of *Fishes of Arkansas*. Most recently, Dave Neely joined the project, photographing a number of Arkansas fishes for the second edition.—*Ginny Adams*

FLORIDA

Carter R. Gilbert, University of Florida Museum of Natural History and Department of Zoology (retired) published an article regarding the formerly “lost” collection by David Starr Jordan at Butler University [Proceedings Indiana Academy Sciences Vol. 118 (2):143-186]. Carter is the author for the Dasyatidae and Engraulidae chapters in the upcoming *Freshwater Fishes of North America* book edited by Mel Warren and Brooks Burr. Although not exactly on Florida freshwater fishes, we are always happy to report on Carter’s activities.

Jacqueline Langston, Pam Schofield (USGS, Gainesville), Jeffery Hill (University of Florida, Ruskin), and Bill Loftus (USGS retired/volunteer; Aquatic Research & Communication, LLC, Homestead, Florida) published a paper offering insight into potential lateral movements between coastal drainages by the African jewelfish [Copeia 2010 (3):475-480].

Pam Schofield, Bill Loftus (affiliations above), Robert M. Kobza, and Mark I. Cook (South Florida Water Management District, West Palm Beach), published an eco-physiology study on the Mayan Cichlid and African Jewelfish, exploring cold snap survival in different habitats in south Florida and offering predictions regarding ultimate geographic expansion based on latitude and thermal isoclines [2009 Biological Invasions 85:51-59].

Howard Jelks, Steve Walsh, and N. Burkhead (USGS Gainesville), have contributed a chapter to the *Freshwater Fishes of North America* book, focusing on differences between Canada, the United States, and Mexico in federal listings of imperiled fishes. Steve also authored the chapter on the Elasmomatidae.

Noel Burkhead, Howard Jelks, and Steve Walsh are preparing a manuscript updating and analyzing current extinction levels among North American freshwater fishes. The total number of extinct taxa has increased by 71% since the list by Miller et al. (1989), now totaling 60 taxa. Only three of the extinct fishes occur in the area represented by the SFC: Harelip Sucker, Whiteline Topminnow, and San Marcos Gambusia.

Pam Fuller (USGS, Gainesville) notes that anyone wishing to check on the status of nonindigenous fishes for Florida should visit the Nonindigenous Aquatic Species Database at <http://nas.er.usgs.gov/AlertSystem/default.aspx>,

filter Group=Fishes and State=Florida (or any other state of interest). The first record for Green Sunfish was just reported from the Suwannee River system. Thirty-seven fish species were introduced into or expanded into new drainages within Florida; not all of these introductions survived. Anyone wishing to report a record of nonindigenous aquatic species is encouraged to visit the aforementioned URL.

Steve Herrington (Florida Chapter of the Nature Conservancy, TNC), reports that TNC has been working on restoration of aquatic habitats in Florida. TNC recently led and completed a multi-partner effort to manage, fund, and complete a dam removal and stream restoration project at Fred Gannon Rocky Bayou State Park in Niceville, FL. TNC also teamed with the U.S. Fish and Wildlife Service, Florida Fish and Wildlife Conservation Commission, Florida Division of Recreation and Parks, and Florida Department of Environmental Protection to remove “Puddin Head Lake,” an impoundment that engulfed over 90% of a steep-head stream traversing the park.

The U.S. Army Corps of Engineers has been using the existing lock to provide fish passage at Jim Woodruff Lock and Dam under a multi-state, multi-agency partnership since 2005. Partners include the USACE, USFWS, NOAA, USGS, Alabama Department of Conservation and Natural Resources, Georgia Department of Natural Resources (GADNR), Florida Fish and Wildlife Conservation Commission, Clemson University, and TNC. GADNR is specifically researching the effectiveness of these operations for the passage and population recovery of Alabama Shad. Objectives this year included estimating the spawning population size of Alabama Shad in the Apalachicola River, quantifying upstream passage of shad through Jim Woodruff Lock and Dam by way of the navigation lock, and determining use of the Flint and Chattahoochee rivers by spawning shad that pass upstream of the lock. Their population estimate for Alabama shad in 2010 was 98,469 (95% CI 51,417 – 127,251), the largest since the start of the project. Transmitter-tagged shad passed through the lock but were only captured in the Flint River. GADNR captured shad without transmitters in both rivers, as well as young-of-the-year, providing further circumstantial evidence that fish passage at JWLD may be enabling shad to reproduce upstream of the impoundment. Research in 2011 will include the previously listed objectives, as well as otolith microchemistry analysis. Lastly, in October 2010, the USACE, USFWS, NOAA, GADNR, ADCNR, FFWCC, and TNC agreed to develop a cooperative agreement to formalize this fish passage partnership.

Frank Jordan (Loyola NOLA) and Howard Jelks (USGS) continue to assist Bill Tate (USFWS, Panama City) in assessing the response of Okaloosa Darters to restoration projects on Eglin Air Force Base. Impoundments on

Tom's Creek and Anderson Branch have been modified to restore lotic conditions to several kilometers of stream habitat. The team is also collaborating with Jim Austin (University of Florida) in determining genetic structure of darters in each stream system. The Okaloosa Darter is in the final stages of being downlisted from endangered to threatened. The combination of field research and laboratory genetic studies should provide valuable insight in the future management of Okaloosa darters.

George Burgess (FLMNH), Noel Burkhead, Howard Jelks, Carole McIvor, Steve Walsh (USGS), Ted Hoehn, Eddie Matheson, John Knight (FWCC), Frank Nordlie (UF Zoology Department), Bill Tate (FWS), and Scott Taylor (Brevard Co. Parks), will meet in Gainesville in late November to review the Florida state list of at-risk fishes.

Jim Williams, along with coauthors Bob Butler and Gary Warren, continue to work on the Florida freshwater mussel book manuscript. This project was funded as a State Wildlife Grant by the Florida Fish and Wildlife Conservation Commission. The completed manuscript is due to be turned in early 2011. Jim is also the Chair of the AFS Mussel Subcommittee and reports that the revision of the AFS list of imperiled North American mussels will be completed in 2011.—*Noel Burkhead*

GEORGIA

Chris Skelton (GCSU) received funding from GADNR/State Wildlife Grant to develop an online guide to the Crayfishes of Georgia. The site will include species accounts, photographs, and dichotomous keys. The project is scheduled for completion in 2012, with intermediate products being posted online as they become available.

Cecil Jennings and Patrick Ely (UGA) have started a new project to assess the abundance, size structure, and spawning locations of Robust Redhorse in the Broad River system.

Gary Grossman (UGA) and colleagues published several papers in the new Stream Fish Communities book published by AFS. These chapters explore linkages between environmental variability and patterns of community structure in stream fishes and provide an alternative explanation for longitudinal gradients in diversity in stream fishes. They continue to work on population dynamics and habitat use of stream fishes and published a paper on density-dependence in southern Brook Trout in *Freshwater Biology*. They finished a study of the effects of stocking rainbow trout on assemblage structure and microhabitat use in native fishes (Duncan Elkins' PhD), and are working on projects involving microhabitat use by southern Brook Trout and diel microhabitat use in Piedmont Darter.

Anna George (Tennessee Aquarium), Dave Neely, Brett Albanese, Josh Smith (Conasauga River Alliance) and many others have continued work on the Colvard Spring

restoration project for Coldwater Darter. Large accumulations of fine sediment are being pumped out of this spring and resulting changes in macrophytes and darter population size are being monitored. The second year of sediment pumping is occurring as this goes to press.

Mary Freeman (USGS) and Bud Freeman (UGAMNH) are working collaboratively with USFWS, TNC, and GADNR to survey fishes in the lower Etowah and Coosawattee Rivers. This project has documented the first occurrences of Amber and Freckled darters within this Coosawattee River system as well as the persistence of Trispot Darter. A goal of the project is to document biodiversity and help guide management of river flows from Carters and Allatoona reservoirs. Other folks from the Freeman Lab, including Megan Hagler and Christina Baker have been studying longitudinal changes in fish and macroinvertebrate assemblages, algal growth, and stable isotopes in plants and consumers in the Conasauga River, to estimate potential influences of agricultural runoff. Greg Anderson has completed his thesis work on the distribution and reproductive behavior of two forms of Holiday Darter in the Etowah River system. Carrie Straight has been tracking the movements and spawning behavior of Robust Redhorse in the Broad River system. Rachel Katz is using mark-recapture methods to study stream fish survival and recruitment in relation to flow variation.

Gerald Dinkins (McClung Museum/Dinkins Biological Consulting) pushed the range of Interrupted Rocksnail downstream in the Oostanaula River by several miles, during a mollusk survey conducted for the Corps of Engineers.

Noel Burkhead (USGS-Gainesville) has received funding from the Athens Field Office (USFWS) to describe the populations of the Holiday Darter from the Conasauga River (Georgia and Tennessee), upper Coosawattee River, Amicalola Creek system, and upper most Etowah River mainstem. The descriptions should be completed by end of 2011. Images of the new forms are depicted on the SFC website. Noel also collaborated on a paper describing the Red Shiner invasion in Georgia [<http://www.springerlink.com/content/h663231513843388/fulltext.pdf>]

Robert Bringolf (UGA) has several graduate students doing fish work in the state. Russell Parr (MS student) is sampling Tripletail off the GA coast to determine age structure, growth rates and reproductive status. He is also trying to determine if non-lethal sampling techniques can be used for monitoring reproductive status by comparing plasma vitellogenin to gonad histology. Josh Seehorn (MS student) is assessing Brook Trout population (size, length/age structure) responses to installation of structures in NE Georgia streams. He has sampled streams across NE Georgia before and one year after structures were installed. He has also quantified changes in physical habitat (depth, substrate composition, etc.). Kristen Kellock (PhD student) is

sampling *Micropterus* spp. from across the state (rivers & lakes) to determine the rate of intersex. Fish from rivers are being collected upstream and downstream from municipal wastewater treatment effluents. Fish from lakes are being collected from PFAs across the state to serve as an indicator of the 'background' incidence of intersex. She is also collecting water from each of these sites at the time of fish collection for analysis of estrogens, which have been linked with the intersex condition in other studies.

Tim Bonvechio and other Fisheries staff from GADNR completed Flathead Catfish removals from the Satilla River for the 2010 sampling season. For the season (May-October), the crew removed 6,289 Flathead Catfish totaling 11,101 pounds. Since the implementation of the full time Flathead management program in 2007, more than 53,671 pounds of Flathead Catfish (19,761 fish) have been removed from the river in 4 years. The size structure of the flathead population has been affected with the average size fish removed dropping from 5.8 pounds in 2007, to 2.9 pounds in 2008, to 1.4 pounds in 2009, but slightly increased to 1.8 pounds in 2010. Tim also recovered a partially digested but well intact, juvenile Atlantic Sturgeon (159 mm total length, 17g) in the stomach of a Flathead Catfish (382 mm TL, 575g) in the Satilla River on 9 June 2010. This was the first confirmed field observation of flathead catfish predation on a sturgeon of any species. Richmond Hill Hatchery staff are rearing approximately 50,000 eight inch Striped Bass that will be stocked in the Savannah and Altamaha River systems this fall as part of an ongoing effort to restore native striped bass populations. The projects goals are to establish self-sustaining Striped Bass populations in these rivers. Fall and winter Striped Bass standardized sampling is part of this effort and will continue through the spring of 2011. Region 1 DNR Fisheries staff stocked over 30,000 Lake Sturgeon fingerlings in the Coosa River basin in 2010 in a continuing effort to restore this fish to its native range. This year Fisheries personnel received the highest number of Lake Sturgeon sightings in the basin since 2004, suggesting that the restoration project is proceeding well. Over 120,000 Lake Sturgeon fingerlings have now been released into the basin since the program began in 2002.

Bill Birkhead (Columbus State University) has begun sampling the Chattahoochee in Columbus prior to the removal of the Eagle and Phenix and City Mill dams. He will also be sampling sandhill streams on Ft. Benning in November in an effort to resolve the reason(s) for low IBI scores "earned" by these streams. Finally, in August he sampled the lower-most reach of Upatoi Creek and an adjacent downstream sector of the Chattahoochee for Bluestripe Shiners. He has not examined all of his voucher specimens yet, but it appears that Bluestripe Shiners were not collected despite their historical presence at these sites.

David Belcher (Valdosta State University) and his graduate student, Matthew Cannister, completed a 45 site ichthyofaunal survey of the Withlacoochee River in 2009 and 2010. The survey yielded 51 fish species, of which 3 (Alabama Shad, Suwannee Bass, and Metallic Shiner) are species of concern in Georgia. The first known sympatric populations of Everglades Pygmy Sunfish and the recently described Gulf Coast Pygmy Sunfish were found at one location.

Brett Albanese and other Nongame staff from GADNR completed fish surveys on Talking Rock Creek and floated the entire section between Hwy 136 and Carter's Lake Regulation reservoir. This is a very remote section traversing tall cliffs. Only one Bridled Darter and one Goldline Darter were captured during these surveys, but additional sites need to be sampled. Extensive patches of *Justicia* and filamentous algae suggest possible nutrient pollution in the headwaters of Talking Rock Creek. GADNR has been working with Katie Owens (The Nature Conservancy), Bill Ensign (Kennesaw State University), and Tim Pugh (Paulding Co.) to monitor populations of Etowah and Cherokee darters before and after a stream restoration project in Raccoon Creek.

The Stream Survey Team (SST) of GADNR conducted fish IBI sampling on streams in the Chattahoochee (6), Ocmulgee (7), Oconee (4), Satilla (8), Suwannee (10), and Ochlockonee (12) river basins. Their IBI protocol for scoring fish communities in the Coosa and Tennessee basins of the Blue Ridge ecoregion will be released by the end of the year. SST staff also assisted in the Colvard Spring project, coordinated their Division's input to the Statewide Water Planning effort, and oversaw the collection of 65 fish species and two amphibian species for pools and aquaria at the new Go Fish Education Center in Perry, GA.—*Brett Albanese*

KENTUCKY

The Kentucky Dept. of Fish & Wildlife Resources (KDFWR) in cooperation with U.S. Fish & Wildlife Service (USFWS) continues efforts to restore extirpated native populations of Lake Sturgeon and Alligator Gar. Lake Sturgeon reintroduction efforts began in 2007, focused on re-establishing a self-sustaining population in the middle Cumberland River drainage from Lake Cumberland to Cumberland Falls, where historic presence has been confirmed. This section includes major free-flowing tributaries such as the Big South Fork and Rockcastle rivers. Fertilized eggs are received annually from Wisconsin Dept. of Natural Resources taken from upper Mississippi River basin stock; young are then hatched and reared at the KDFWR Pfeiffer Hatchery prior to release. Although still too early to evaluate success, several reported captures by anglers during the past two years have been confirmed

from Fishing Creek (impounded) upstream to the Laurel River confluence. A telemetry study is being planned for the near future to better understand movements and habitat affinities of released fish.

In 2009, KDFWR, in cooperation with USFWS, committed to a long-term project aimed at restoring the Alligator Gar to its former native range along the lower Ohio and Mississippi rivers in western KY. Gar fry are received annually from the Private John Allen National USFWS Fish Hatchery, and are reared at KDFWR hatcheries prior to release. Release sites are situated in areas where the species is known to have occurred historically and which still provide suitable habitat. During 2009, a total of 4,726 individuals ranging from 18.5-34.5 cm were released in the following systems in western Kentucky: Clarks River (lower Tennessee R), Phelps Creek (lower Ohio R), Bayou Creek (lower Ohio R), Tradewater River (lower Ohio R), Deer Creek (lower Ohio R), Massac Creek (lower Ohio R), Mayfield Creek (Mississippi R), Obion Creek (Mississippi R), and lower Bayou du Chien (Mississippi R).

This year, KDFWR awarded a State Wildlife Grant (SWG) to Michael Flinn and graduate students at Murray State University to conduct a telemetry study of recently released Alligator Gar in the Clarks River system. In early October, telemetry tags were surgically implanted in 20 individuals, which were then released in the Clarks River (McCracken Co.) near Paducah, KY. These tagged individuals were released approximately 5 to 7 miles upstream of the confluence of the Clarks River with the Tennessee River. For the following six days, these fish were tracked using stationary and active tracking methods via motorboat and kayak. Preliminary results revealed a somewhat random pattern in initial movements, with respect to upstream and downstream directions. Initial 24-hour movements ranged from 1-5 miles; most fish moved less on the second and third days. Surprisingly, five individuals moved upstream well beyond what was predicted, passing through three shallow (7-10 cm depth) riffles approximately 20 meters long. Most of these fish were found in a deep pool above the riffles and one was found approximately 2 miles even further upstream (also in a deep pool). To date, no fish have moved out of the Clarks River system into the Tennessee (based on stationary receiver pings).

Michael Floyd (USFWS), Matt Thomas, and Stephanie Brandt (KDFWR), and Ryan Evans (Kentucky State Nature Preserves Commission, KSNPC) have begun work on a range-wide status assessment of Cumberland Arrow Darter (*Etheostoma sagitta sagitta*). Once thought to be more common and stable than the adjacent Kentucky Arrow Darter (*Etheostoma sagitta pilotum*), accelerated habitat loss and water quality degradation throughout the upper Cumberland River basin justify the need for a comprehensive assessment of this species. A status survey con-

ducted from 2007-2009 revealed significant declines in *E. s. pilotum* populations, particularly in the Middle and North Fork Kentucky River drainages where strip coal mining activity has intensified during the past decade. This has prompted the USFWS to recently add Kentucky Arrow Darter as an official candidate for federal listing as threatened or endangered. Headwater stream habitats in the upper Cumberland River basin are under similar pressures, and are likely having similar impacts on Cumberland Arrow Darter. Sampling conducted thus far has detected the species at approximately 53% of streams having confirmed records of historic presence. A large portion of the streams in which arrow darters were present lie within the Daniel Boone National Forest: Indian Creek, Cogur Fork, Marsh Creek, Beaver Creek, Mill Creek, and Big Creek. Beaver Creek, Mill Creek, and Big Creek are all situated below Cumberland Falls. The streams within the National Forest boundaries immediately above and below Cumberland Falls are more forested and generally have higher quality habitat than streams in much the upper Cumberland drainage east of Clear Fork. Although preliminary data suggest population declines in the upper Cumberland drainage, additional sampling is needed to determine the extent of these declines and identify any areas of suitable habitat remaining.

Captive propagation and reintroduction efforts continue for Kentucky Arrow Darter and Cumberland Darter (*E. susanae*). Conservation Fisheries Inc. (CFI), with SWG support, was highly successful this year with captive spawning of Cumberland Darter. In late September, approximately 330 VIE-tagged individuals were released in Cogur Fork (Indian Creek drainage), immediately above Cumberland Falls. This stream is being carefully monitored by Matt Thomas and Stephanie Brandt (KDFWR) to evaluate captive propagation and reintroduction as a tool for restoring extirpated populations or augment declining populations. Similar efforts are underway for *E. s. pilotum* in Sugar Creek (Redbird River-upper Kentucky River drainage). This species has proven to be more difficult to spawn and manage in captivity due to the aggressive nature of adult males. Spawning of Arrow Darters was unsuccessful this year, for reasons uncertain, but brood stock numbers were low and included some individuals that were perhaps "past their prime".

Lisa Hopman and Brooks Burr (Southern Illinois University at Carbondale) are receiving SWG support from KDFWR to study regional variation in Stonecat, with emphasis on the Cumberland and Tennessee River drainages and turbid main channel habitats of the Mississippi River. Preliminary observations, including pigment pattern scoring and body shape analysis reveal diagnostic differences between Cumberland River and Kentucky River drainage (Ohio River basin) populations. A

pale, small-eyed form has thus far been found to occur in the main channel of the Mississippi River from Cairo, IL, to the mouth of the Missouri River, and in the Missouri River upstream to Kansas City, Missouri. Attempts will be made during the next year to obtain additional specimens for morphological and genetic data. An important objective of this study is to better understand processes that drive endemism in riverine fishes. Such information will help conservation managers identify and protect areas that are "hotspots" for diversification.

Peter Zervas, under the direction of Philip Lienesch, at Western Kentucky University completed his master's thesis describing the life history traits of Yellow Bass in Barren River Lake. They documented slow growth rates, most likely as a result of low food availability during fall and winter. Future efforts will include examining lipid content of individuals over the winter and a more in depth analysis of the spawn next spring. They have also been examining the effects of drought on stream fishes in the Drakes Creek watershed (Barren River drainage). They are planning to compare lipid content in Northern Studfish from fall 2010 with fall 2007, after the area experienced a severe drought.

Garrett Stillings, under the direction of Sherry Harrel, at Eastern Kentucky University completed his master's thesis investigating the distribution and status of Blackfin Sucker in the upper Barren River drainage in KY, with State Wildlife Grant (SWG) support. This small sucker is endemic to the upper Barren River drainage of Kentucky and Tennessee, and is listed in KY as a species of special concern due to its limited distribution. Because recent distributional and population data are lacking, the objectives of this project were to document the current distribution of the species in Kentucky, determine age and growth, assess the fish community structure and biotic integrity of streams in the upper Barren River system, assess physical habitat alterations as a contributing cause of population declines, and identify any ecological associations between Blackfin Sucker and other fishes of the Barren River system. Thirty sites in the upper Barren River drainage were sampled, including 14 with prior records of Blackfin Sucker. A total of 34 Blackfin Suckers were collected from nine sites located among three tributaries above Barren River Lake. Maximum total length among specimens captured was 150 mm and a length frequency histogram revealed at least four age classes. A chi-square distance analysis showed that Elegant Madtom has a positive correlation (0.83) and Creek Chub has a negative correlation (-0.67) with Blackfin Sucker. Adults were typically associated with undercut bedrock crevices or large flat rocks. Based on the Kentucky Index of Biotic Integrity scores and Shannon-Wiener Diversity Indices, the mainstem Barren River averages a higher score for water quality (72 ± 10) and diversity (2.34 ± 0.32) than other tributaries that feed the reservoir.

Biological monitoring and assessment continues in Mill Branch, a small headwater tributary to Stinking Creek (upper Cumberland River drainage), in Knox Co., KY. This stream, which supports a population of Blackside Dace, had been degraded by a combination of agricultural and residential impacts, poor logging practices, and some coal mining. In fall 2005, USFWS, KDFWR, and the Natural Resources Conservation Services (NRCS), along with the cooperation of several private landowners, sought to restore the lower 700 meters of Mill Branch to approximate the pre-impacted conditions. In August 2009, the newly restored channel was finally connected to the mainstem and the old channel was eliminated. To determine whether the restoration effort resulted in biological improvement, a one-year post-restoration assessment of fish and benthic macroinvertebrate communities was conducted. Preliminary data suggest that Mill Branch is gradually becoming more stable in terms of habitat, water quality, and the overall biotic community. The Blackside Dace population has increased significantly from the first sampling event in 2006 (prior to construction), and individuals have now begun to utilize areas below a newly installed culvert.—*Matt Thomas*

LOUISIANA

Marty O'Connell with the Nekton Research Laboratory (NRL) at the University of New Orleans (UNO) reports that a few specimens of invasive tilapia (a yet to be determined strain of *Oreochromis*) have recently been collected in the vicinity of Port Sulphur, which is located on the Mississippi River south and downstream of New Orleans. In 2009, the Louisiana Department of Wildlife and Fisheries (LDWF) responded quickly and aggressively to wipe out these invasive fish by closing off the impacted area and applying rotenone to all affected water bodies. Starting in 2010, a team consisting of LDWF personnel and researchers from UNO-NRL and Nicholls State University began monitoring the impact area and stocking native fishes to help post-rotenone recovery. Mike Wood, Melissa Kaintz, and Tim Ruth lead the LDWF team, while NRL post-doc Tom Lorenz and Ph.D. student Jonathan McKenzie conduct the monitoring, and the stocking of native fishes is being carried out by Quenton Fontenot, Allyse Ferrara, and Rachel Ianni (M.Sc. student) of Nicholls State University. After an atypically cold winter, initial monitoring yielded no tilapia and the team was encouraged, but fall sampling began turning up new specimens of tilapia that apparently survived the initial treatment. If further funding is provided, the team hopes to monitor the ongoing situation throughout 2011.

The Deepwater Horizon oil disaster has both generated new research projects and interrupted ongoing NRL research on fishes in southeastern Louisiana. Senior Biologist and Database Manager Meg Uzee O'Connell is

working on new grants from the National Science Foundation and the Harte Research Institute for Gulf of Mexico Studies to compile data on fish habitats and how they may be impacted by the presence of oil. Meg is being assisted in these efforts by undergraduate student worker Jenny Wolff. Ongoing research on the pupping activity of lemon sharks at the Chandeleur Islands has been interrupted due to the disaster. This research is led by NRL Operations Manager and Senior Biologist Chris Schieble who has led two expeditions to the Islands since the event. Other efforts to complete this research have been curtailed due to issues concerning safety and the placement of booms across waterways. Chris is also pursuing new oil spill-related projects funded by Louisiana Sea Grant and the Northern Gulf Institute involving using NRL's pre-disaster baseline data from these areas to assess the amount of damage caused to local fish assemblages.

Graduate student Jonathan McKenzie (Ph.D.) is also working on lemon sharks and is currently investigating the genetic relationships within the population at the Chandeleur Islands. Also on the lemon shark project is Chris Davis (M.Sc.) who is finishing his thesis this fall on lemon shark diet and prey availability. One major finding of Chris's work is that the diet breadth of Chandeleur Island lemon sharks appears reduced compared to other, more southerly populations of this species. Celeste Espinedo (Ph.D.) continues to study behavioral interactions between Texas Cichlid and livebearers in an attempt to determine why these native fishes are declining in the presence of the invasive cichlid. Rebecca Cope (M.Sc.) is studying the effect on larval fishes of the recent closing of an artificial pass into Lake Pontchartrain (due to hurricane protection concerns). Shane Abeare (Ph.D.) completed a success scouting expedition in 2010 to southwestern Madagascar where he will be studying the potential use of seagrasses by nearby coral reef fishes. Patrick Smith (M.Sc.) continues to track red drum that have been restored to an urban fishery in New Orleans. New Ph.D. student Will Stein has completed his first year of fieldwork and has been attempting to assess the condition of juvenile tarpon habitat in southeastern Louisiana.

Conservation-related fish work at Tulane has focused on 1) completing the description of a new species of darter, *Etheostoma* sp cf. *asprigene*, from the Calcasieu, Sabine and Neches river systems of Louisiana and Texas; 2) managing the Fishnet2 information portal; 3) building an information portal on fishes of the Gulf of Mexico for responding the BP Oil Disaster; and 4) completing a demonstration project on the usefulness of portals such as Fishnet2 for assessing conservation status of rare and endangered fish species. The new darter description is to be published in Tulane Studies in Zoology & Botany before the end of 2010. TUMNH took over management of the Fishnet2 network

early in 2010 and changed the portal from a distributed-query-based system to a cached-based system. The change greatly increased the speed and completeness of data searches. We also implemented a .kml file download feature that allows portal users to visualize search results in Google Earth. The new portal is accessible at <http://www.fishnet2.net>. The enhancements were largely the work of Nelson Rios and Djihbrihou Abibou of TUMNH. Also in 2010, TUMNH was awarded a RAPID grant from the National Science Foundation to customize the Fishnet2 portal and search interface so that it can be mined for responding to disasters such as the BP oil spill. We intend to use the oil spill as a use case for the new system. The portal should be ready for use in 2011. A third project related to Fishnet2 is the work of TU graduate student, Justin Mann, which will be reported on at this year's SFC meeting. Justin is applying parametric and nonparametric forms of the probabilistic Solow equation to data (occurrences and abundances) mined from Fishnet2 to reassess the status of 23 of Louisiana's 28 species of concern. He found that 17 of the 23 species showed a significant probability of extinction or threat in at least one of the probabilistic methods, and that 10 species showed significant probability of extinction or threat for all of the methods used. Beyond informing state and federal conservation authorities about threats to Louisiana fishes, he aims to demonstrate the utility of large data sets in natural history collection for conservation status assessments.—*Marty O'Connell*

MARYLAND

The Maryland DNR Fisheries Service is currently working to reintroduce spawning populations of American Shad and Hickory Shad to Chesapeake Bay tributaries in the state. The Choptank, Nanticoke, and Patuxent rivers historically supported substantial populations of both species. Populations declined drastically from the 1950s until fishing moratoriums were enacted (American Shad, 1980; Hickory Shad, 1981). Declines have been attributed to overfishing, poor water quality, and blockages restricting access to spawning habitat. The combination of improved water quality, fishing moratoria, and fish passage programs provides the opportunity to attempt restoration through hatchery inputs, which are being supported by Sportfish Restoration Act funds. Adult broodstock have been collected from tributaries that exhibit stable spawning populations. Strip spawning and hormone-induced tank spawning methods are providing eggs for larval and juvenile culture. All hatchery shad are marked (oxytetracycline immersion or coded wire tags) prior to stocking in the three target rivers. Delaware Fish and Wildlife cooperates on Nanticoke River stocking and assessment on this shared drainage. Surveys to assess juvenile and adult populations

are being conducted in each river to monitor efficacy of the restoration effort.

The Bridle Shiner is now considered extirpated in Maryland. The species has not been observed in Maryland for 26 years and there are only 11 records from the past 50 years. A forthcoming paper by Jay Kilian (Maryland DNR, Maryland Biological Stream Survey) and several co-authors summarizes survey results within the historic range of the Bridle Shiner in Maryland. Targeted sampling at all historic localities since 2003 and more than 2,400 quantitative collections within the species' range since 1995 have failed to locate any Bridle Shiners. The status of the species in Maryland has been changed from endangered to endangered/extirpated (COMAR 08.03.08.06).

The Maryland DNR Fisheries Service is evaluating the potential for Atlantic Sturgeon restoration in Maryland. A federal status review found that spawning stocks appear to be extirpated from all Maryland tributaries of the Chesapeake Bay. Wild, migratory fish that originate from other coastal systems, however, routinely enter Maryland waters to forage as sub-adults. In collaboration with researchers from the University of Maryland, U.S. Fish & Wildlife Service, Mirant Corporation, Virginia Institute of Marine Science, Maryland and Virginia Sea Grant, Virginia Commonwealth University, and the NOAA Chesapeake Bay Office, biologists are determining population genetic structure, habitat use, and population size of Atlantic sturgeon. Techniques are also being developed for sperm cryopreservation to ensure availability of male gametes for possible stock augmentation. Some Atlantic Sturgeon captured by commercial fishermen have been added to captive brood stock at one of the partnership culture facilities.—*Rich Raesly*

MISSISSIPPI

Gretchen Grammer (Grand Bay National Estuarine Research Reserve, GBNERR) reports their involvement in a number of active projects. They are conducting a long-term study (2005 - present) documenting the temporal characterization of fish communities of nearshore habitats within the GBNERR. In addition, they are evaluating the community structure of fishes in a freshwater system at the GBNERR using passive gear with an emphasis on the population structure and movement of Spotted Gar, Bowfin, and Brown Bullhead. Lastly, several staff at the GBNERR are actively integrated in conservation planning for Saltmarsh Topminnow where they have been identifying habitat needs and threats across its entire range and ultimately hope to develop a regional conservation plan that would outline strategies for increasing the viability of this species in the northern Gulf of Mexico.

Matt Roberts, the new ichthyologist at the Mississippi Museum of Natural Science, has been busy during his first

year on the job, and reports active research and collaborative efforts in the following projects: status survey of the Piebald Madtom; habitat use, population status, and trophic ecology of the Gulf Sturgeon in the Pascagoula estuary; population genetics of the Pearl Darter in the Pascagoula River; fish and mussel interactions on the Tennessee-Tombigbee Waterway; fishes surveys along the Tennessee-Tombigbee Waterway; distribution and population genetics of the Yazoo Darter; conservation planning of the Saltmarsh Topminnow; and curation of the State's fish collection housed at MMNS.

Jake Schaefer, Brian Kreiser (University of Southern Mississippi) and Dave Duvernell (Southern Illinois University Edwardsville) continued their work on contact zones among species in the *Fundulus notatus* species complex. Blackspotted Topminnow and Broadstripe Topminnow co-occur and hybridize in the Pontchartrain drainage while Blackspotted and Blackstripe topminnows co-occur and may (not always) hybridize in numerous contact zones throughout their broadly overlapping ranges. The research is focused on assessing patterns of co-occurrence and hybridization across these replicate contact zones. Within each contact zone, 8-10 samples are taken along a gradient defined by sites dominated by either species on the ends. To date, contact zones have been sampled in twelve drainages including: the Amite, Pearl, Pascagoula, and Tombigbee in Mississippi, the Sabine and Neches in Texas, the Kiamichi, Little and Illinois Rivers in Oklahoma, Shoal Creek in Missouri and Kansas, Sexton Creek and Cache River in Illinois, Duck and Elk Rivers in Tennessee and the Strawberry River in Arkansas. The structure of contact zones (distributional pattern of parental species) is not consistent but appears to be related to the strength of ecological gradients. Rates of hybridization are also not consistent. Some contact zones feature multiple sites with both species but no evidence of hybrids while other zones have sites that are dominated by F1 or individuals of hybrid ancestry. The team is interested in the implications of different contact zone structure on the ecology and evolution of the populations in these systems. The phylogeographic component of the project is being tackled by Brian Kreiser. Brian has sampled all species in the complex nearly range wide and is finding some interesting patterns of diversity. Students at the University of Southern Mississippi are pursuing a number of questions regarding the contact zone work. Charles Champagne (MS) is studying the diet and feeding morphology of the two species across the contact zone. Melissa Gutierrez (MS) completed her MS thesis on mate choice dynamics, showing that female Blackspotted Topminnows prefer males based on body size and spot density. Melissa and Wilfredo Matamoros (PhD) have also undertaken a mark-recapture study to estimate movement dynamics,

population size and habitat use of Blackspotted Topminnows in a local creek. Other students not working with *Fundulus* include Scott Clark (feeding ecology of Chain and Grass Pickerel), Paul Mickle (ecology of Alabama Shad), Wilfredo Matamoros (biogeography of Honduran fishes) and Bjorn Schmidt (project undefined). Wilfredo completed his dissertation in the summer and is now a postdoctoral researcher at the Louisiana State University Museum of Natural Science working with Prosanta Chakrabarty. Paul Mickle is working hard to finish his dissertation by next fall.

Eric Dibble, Mississippi State University, is developing best management practices for invasive plant control and restoration of the sport fishery in Mississippi Delta Lakes. Goal of this research is to develop best management practices regarding chemical and biological aquatic plant control methods to restore habitat and facilitate fishery management goals in Mississippi Delta lakes. Specific objectives are to compare two control methods (Grass Carp and herbicides) for invasive/nuisance aquatic plants; determine potential influences of the two plant control methods on fish populations and habitat, water quality and public use; and to develop best management practices for aquatic plant control relative to Delta oxbow lakes fishery management.

Larry Pugh (Mississippi Department of Wildlife Fisheries and Parks, MDWFP), described four projects undertaken by his agency. In 2009, the USFWS awarded a contract to the Lower Mississippi River Conservation Committee (LMRCC) to re-build a washed-out stone dam at Lake Perry Martin. Personnel from the LMRCC, the USFWS and MDWFP worked jointly towards meeting the project goal. The work was completed on time and under budget in August 2010, and MDWFP will re-stock Lake Perry Martin with fish. MDWFP personnel also completed a cooperative project with the USFWS's Pvt. John Allen National Fish Hatchery to stabilize a section of stream bank and improve habitat for Southern Walleye on Mackeys Creek in Prentiss Co. This is the first phase of a Southern Walleye restoration project on this headwater stream of the Tombigbee River. Funding for the project was provided by the Southeastern Aquatic Resources Partnership (SARP). This partnership includes all southeastern state fish and wildlife agencies, as well as all federal agencies responsible for natural resources management in the southeastern U.S. The MDWFP is also sampling sturgeon on the LMR as part of a multi-agency cooperative effort to document population metrics of sturgeon species (both Shovelnose and Pallid) in the LMR and are conducting fish community assessments and angler creel surveys on the Lower Pearl River.

Daniel Drennen (USFWS-Jackson Field Office), reports that Greg Easson and students at the Mississippi Mineral Resource Institute at The University of Mississippi are working on a GIS project investigating fish passage

barriers for the Yazoo Darter in the form of culverts, bridges and low-water crossings. Daniel has also initiated planning for an upcoming Bayou Darter and Bayou Pierre stakeholders meeting to discuss updates on the status of the Bayou Darter, concerns about the species and the system, and to identify possible projects within the tributaries and mainstem of the Bayou Pierre.

Paul Hartfield (USFWS) reports that the Jackson, MS, USFWS-ES office is collaborating with The University of Louisiana at Lafayette (ULL) to monitor and quantify the 2010 and 2011 juvenile Ohio River Shrimp migrations in the Atchafalaya River (a distributary of the Mississippi River) in response to the Deepwater Horizon Oil spill occurring during the summer of 2010. The timing of the oil spill is concurrent with the larval saline stage and has the potential to significantly reduce the 2010 river shrimp cohort, particularly in the Mississippi River system. In order to determine impact and severity of the oil spill on river shrimp in the Mississippi River system, migrating juvenile shrimp numbers for both years will be compared with estimates of juvenile migrant shrimp reported in 2008. Downstream quantification methods include nocturnal video surveillance, adult shrimp traps, and juvenile migrating traps developed by ULL. Monthly samples (July 2010 through November 2011) of Ohio River Shrimp (2009 pre-spill cohort) are being taken at MRM 430 and 580 to determine long term effects to the numbers and demographics of the upriver Ohio River Shrimp population and possible impacts to the river community food chain. Upstream collection methods include modified shrimp trawls, adult and juvenile traps, and nocturnal seining. This sampling program should also provide insight on migration rates, migration cues, and possibly longevity of the species.

Mark Peterson (USM-GCRL) commented that Erik Lang recently defended his thesis research focusing on the reproductive life history of Saltmarsh Topminnow and the comparative development of sympatric fundulid species. This work will integrate well with the range-wide efforts to develop a comprehensive management plan for this species. Jeanne-Marie Havrylkoff completed her thesis work with Gulf Sturgeon in the Pascagoula estuary and has stayed with the lab to participate in additional funded projects focusing on various aspects of Gulf Sturgeon. These projects include varying collaborative efforts between Peterson, Todd Slack (U.S. Army Corps of Engineers, Research and Development Center, Vicksburg), and Matt Roberts (MMNS), and address juvenile and sub-adult Gulf Sturgeon habitat use in the Pascagoula estuary and participation in the range-wide study to assess potential impacts of the Deepwater Horizon oil spill on Gulf Sturgeon.

Glenn Parsons (University of Mississippi) and Steve Miranda (Mississippi Cooperative Fish and Wildlife Unit, Miss. State University) are radio-tracking Black and White

Crappie in Sardis Reservoir to determine movements and habitat use, successfully tracking 25 fish during the first year of the study. A second project involves the development of a device that is placed in a trawl and reduces the bycatch of unwanted fishes during shrimping (with funding from WWF). One device consistently provides ca. 40 to 50% bycatch reduction with high shrimp retention. Glen has also developed a shark bite force meter, that he and his students have so far used to assess bite force in Bull, Spinner, Blacktip, Sharpnose, Blacknose and Finetooth sharks. They are also using this device to monitor stress levels in sharks reasoning that the bite force will decrease as stress increases.

The Shark Research Program at the University of Southern Mississippi's Gulf Coast Research Laboratory has been conducting active research in the region for over eight years. Personnel include Dr. Eric Hoffmayer, Jim Franks, Jill Hendon, Jennifer McKinney, William Dempster, Gary Gray, Chris Butler, Art Karels, and Jason Tilley. There are several funded projects that are currently being conducted on coastal and pelagic shark species. Their research on coastal shark species in the Mississippi & Chandeleur Sound, uses gillnets and longlines to primary document the seasonal distribution and abundance of several coastal shark species. Other inshore activities include tag & release, feeding ecology, stress physiology, age, growth, and reproduction, and movement pattern studies of coastal sharks within Mississippi waters. Studies on pelagic species primary focus on essential fish habitat requirements through the use of satellite telemetry. A two year study investigating the environmental preferences and habitat use patterns of Dusky and Silky sharks in the northern Gulf of Mexico was recently completed. Studies on the occurrence, distribution, and movement of Whale Sharks in the northern Gulf of Mexico continue, with increased effort during 2010 to better understand how this species have been impacted by the Deepwater Horizon oil spill. In the fall of 2010, Dr. Hoffmayer's graduate student, Jennifer McKinney, defended her Master's thesis where she developed a species distribution model of Whale Sharks in the northern Gulf of Mexico. Dr. Hoffmayer and Jill Hendon teach a Shark Biology course for the University of Southern Mississippi's Summer Field Program each year as well as mentor several undergraduate students each summer.

Fish Ecology Team members at the US Army Engineer Research and Development Center and their collaborators continue to work with local large river and wetland fish communities. Jack Killgore completed the user's manual for Envirofish, a model based on nearly 20 years of Yazoo Basin data that evaluates effects of flood control projects on fish habitat. Jack is developing an index of habitat quality for secondary channels based on data collected from aerial videography by Bradley Lewis. Jack also coordinates

all field sampling for sturgeon in the Mississippi River. Steven Divers, College of Veterinary Medicine University of Georgia, led another endoscopy study of Pallid and Shovelnose Sturgeon to determine reproductive stages and short-term effects of large tissue biopsies. This was done in conjunction with a survey of contaminants in sturgeon tissues by Dave Johnson (a toxicologist at ERDC) and Jan Hoover. Nick Friedenberg, Applied Biomathematics, is working with several Team members and their field data to develop population viability models for sturgeon and to evaluate impacts of water diversions. Krista Boysen completed a decision support model for ranking restoration alternatives in the Mississippi River and began work this year as a graduate student with Rob Wood at St. Louis University studying genetics of Shovelnose and Pallid sturgeon. Steven George and Todd Slack determined fecundity for Pallid Sturgeon recovered in "ghost nets" in the Atchafalaya River. Audrey Harrison, student researcher at Mississippi College (presently Clemson University), quantified cicadas in the diet of Shovelnose Sturgeon. Jan Hoover coordinates field studies of Asian carp in a Forest Home Chute, a backwater system of the Mississippi River. Cliff Ochs and Nok Pongruktham, University of Mississippi, are collaborators on a study of Asian carp impacts on plankton. Larry Southern, Mississippi State University student researcher, analyzed pectoral rays of Bighead and Silver Carp and demonstrated growth rates higher than those of carp in Asia and in the Middle Mississippi River. Alan Katzenmeyer, student researcher at Louisiana Tech, studied swimming performance in Bighead Carp, documenting that groups of juveniles swim faster than individuals, and that subadult Bighead Carp swim faster than Silver Carp. Jay Collins is working on carp-deflectors to protect boat-drivers and a carp-catching cage to protect small water bodies.—*Todd Slack and Jan Hoover*

MISSOURI

The Missouri Department of Conservation (MDC) performs annual monitoring of fish populations, communities, and habitat to support recovery of four federally and state listed small stream fishes: Niangua Darter, Topeka Shiner, Neosho Madtom, and Ozark Cavefish. Data collected during 2009 by Resource Scientist Doug Novinger and assistants represented from 6 to 9 years of consecutive, consistent surveys.

Patterns in abundance and distribution of Niangua Darter populations changed minimally compared to previous years. The species occupied five of eight historical watersheds and trend analyses showed that population densities of adult-sized Niangua Darters can be considered stable or increasing. Size-structured differences in habitat use by Niangua Darters support a conservation emphasis on maintaining habitat heterogeneity to ensure that the ecological requirements of the full range of ages in a

population are met. In addition, habitat diversity may be a critical factor linking Niangua Darters to generally high levels of darter species diversity. Our monitoring of sites associated with low water crossings highlighted numerous benefits to habitat and Niangua Darter populations following replacement of the crossings with clear span bridges. A recently completed study by Missouri State University documented significant movement among habitat patches and through a crossing corridor.

Topeka Shiners remained abundant and broadly distributed in only one watershed in central Missouri. A second watershed in northwest Missouri is still occupied by the species but abundances and distribution are highly restricted. Similar to previous years, abundances of Topeka Shiners were highest in upstream sites on the mainstem and in a headwater tributary of the central Missouri watershed. Our analysis of temporal trends supported the overall conclusion that this population of Topeka Shiners is stable or increasing.

Neosho Madtom distribution in the lower 15 miles of the Spring River of southwest Missouri remained consistent with previous years. Counts of the species were low; however, patterns of microhabitat use highlighted the importance of a riffle's tail and channel margin with corresponding range of depths, velocities, and moderately loose gravel and pebble substrates. Monitoring during the last three years has been marked by the collection of significant numbers of juvenile Neosho Madtoms.

Several new sites occupied by Ozark Cavefish have been discovered during last three years, bringing the total number of active/accessible sites in the Springfield Plateau of southwest Missouri to 21. Many of the recent sites are old hand-dug, rock-lined wells that offer excellent observation and research opportunities. Significant numbers of juvenile Ozark Cavefish have been observed in several sites. Recent and ongoing research has resulted in the delineation of most active site recharge zones, detailed descriptions of water quality associated with urban and agricultural landuse and mining, and increased understanding of Ozark Cavefish biology and site occupancy.

While filming and photographing fishes for a documentary on the diversity of southeastern United States fishes (with Jeremy Monroe of *Freshwaters Illustrated*), two new distributional records were documented. Stippled Darter was collected from Grassy Creek (Castor River drainage) in a small pool in heavy cover. The pool and snags were diligently sampled before dislodging the specimen. We suspect higher numbers of this species may occur farther upstream in Grassy Creek and in other small tributaries to the Castor River as this species prefers very small headwater situations and abundant cover, which is common in the area. The last time this species was collected in the Castor River drainage was in 1964 (46 years ago). During this same

project, a single specimen of Southern Brook Lamprey was collected from the Castor River in Madison Co. (farther up the Castor River drainage than the Grassy Creek site). This species had never been collected in the Castor River system and, as a matter of fact, is only the second collection from southeastern Missouri (the other being from the St. Francis River). This species is widely distributed, although uncommon, in the central and western Ozarks in Missouri.

Pallid Sturgeon have been documented from the Mississippi River above the confluence with the Missouri River based on photographic, telemetry, and capture evidence. In 2004, a commercial fisherman caught a pallid-like sturgeon in Upper Mississippi River Navigation Pool 22 near Saverton, Missouri. Before releasing the fish, the commercial fisherman took a photo of the specimen and it was determined to be a Pallid Sturgeon. In December 2009, Danny Brown of the MDC captured a single Pallid Sturgeon in the Upper Mississippi River and in October 2010 caught a second specimen in the tailwaters of Lock and Dam 25 (Navigation Pool 26) in a gill net. Staff at the Open Rivers and Wetlands Field Station (MDC), collaborating with Southern Illinois University-Carbondale, have established a stationary ultra-sonic telemetry-array to detect long-range movement of fishes in the Mississippi River from Iowa to Arkansas. Through the telemetry system, staff have documented Pallid Sturgeon in the Upper Mississippi River to Lock and Dam 22. Reports are available through MDC's *Science Notes* series.

Crystal Darters are endangered in Missouri where its historical distribution occurred in seven drainages, but it has not been reported in two of those drainages since the mid-1900s. It is conceivable, given known habitat requirements (i.e. deep, sometimes swift water) that this species was inadequately sampled across much of its range. Seines have been traditionally used to capture small-bodied, benthic fishes, but with the recent development of benthic trawls the efficiency of capture of such fishes has dramatically improved. The implementation of the Missouri Trawl and targeted efforts has resulted in new distributional records and range extensions for Crystal Darter in Missouri. For example, using the Missouri Trawl, the first known occurrences of this species were documented in the Middle Mississippi River in 2005. In the Gasconade River, 29 individuals were captured at nine new localities using the trawl during 2008 and 2010, doubling the number of Crystal Darter reported in that drainage from 1947-2000. Three of those localities resulted in a significant range extension upstream in the Gasconade River. Recent occurrences have also been documented in the Big, Meramec, and Black Rivers using the Missouri Trawl. Based on past sampling efforts it was hypothesized that Crystal Darter was declining in Missouri, however recent records from trawling data suggest this may not be the case. However,

caution should be exercised as we interpret data collected by trawls as it is conceivable that trawls allow investigators to cover large expanses of rivers, but areas of potentially favorable habitat may still be dwindling.—*Robert A. Hrabik*

NORTH CAROLINA

In August 2009, NCSM staff confirmed the presence of Banded Sculpin in North Carolina based on specimens collected from Big Creek, in the Pigeon River drainage of Haywood Co., by Messer in 1963 (NCSM 55213). This is the first documented record from the state since 1869. In August 2009, Starnes and Tracy collected Banded Sculpin from two sites on Shut-in Creek and from the French Broad River at the mouth of Shut-in Creek near the Town of Hot Springs (NCSM 55216, 55220, and 55218, respectively). The same field effort also resulted in two specimens of Tennessee Darter from Shut-in Creek (NCSM 55217), representing the first verifiable record of this species for the state since 1869 and the only record currently represented by vouchers. Two questionable records from Spring and Laurel creeks in Madison Co. (Etnier and Menhinick, pers. com.) should be disregarded until any vouchers that may exist are found.

Until 2007, the lone North Carolina record of Mountain Madtom was from Spring Creek at the town of Hot Springs, Madison Co. collected in 1888 (UNSM 40405). The species was long thought to be extirpated from the state, until a single individual was collected in 2007 by S. Fraley and T. Russ from the French Broad River at the town of Hot Springs (NCSM 52482). In 2009, four juveniles and one adult were collected by Starnes and Tracy from three localities in Madison Co. — the French Broad River near the mouth of Shut-in Creek, the French Broad River near the mouth of Grass Creek, and Spring Creek at the town of Hot Springs (NCSM 55219, 55221, and 55210, respectively).

The North Carolina Wildlife Resources Commission (NCWRC) is currently reviewing the protected status of sixteen listed fishes (in part due to the records above). For a complete list of proposed changes or to submit comments, please contact Bryn Tracy.

In April 2009, 101 specimens of Roanoke Hog Sucker were collected by the North Carolina Division of Water Quality (NCDWQ) from Pauls Creek, a tributary to Stewarts Creek and the upper Ararat River in Surry Co. These represent the first record of this species from the Yadkin drainage. The specimens ranged from 41 to 109 mm total length and represented age I–III fish based upon length frequency plots. Additional surveys by R. E. Jenkins, Starnes, and Tracy identified five additional populations in Brushy, Pauls, and the middle portion of Stewarts Creek. Tracy, Jenkins, and Starnes (manuscript in prep.) suspect that this range extension is a consequence of one or more

recent bait bucket releases by fishermen seeking trout and Smallmouth Bass. The closest source population is the Dan River in central Patrick Co., ENE of Pauls Creek.

Additional discoveries of introduced populations of indigenous species to drainages outside their native range include: Mountain Redbelly Dace, Middle Creek, Macon Co. of the Little Tennessee River system; Rosefin Shiner, Fourth Creek, Iredell Co. of the South Yadkin River subsystem of the Pee Dee drainage; Highback Chub, Little River and Pine Swamp, Glade, and Brush creeks (tributaries to the Little River) in Alleghany Co. of the New River system and probably introduced from the adjacent Pee Dee drainage; Brown Bullhead, Naked Creek in Ashe Co. of the New River system; and Snail Bullhead, Tuckasegee River at Whittier, Swain Co. of the Little Tennessee River system.

The nonindigenous Oriental Weatherfish is reported for the first time from North Carolina. The species was collected at three sites in the upper Haw River subsystem in Guilford and Alamance counties of the Cape Fear River drainage. Two specimens were collected in April 2009 and another in June by staff from the NCDWQ and the City of Greensboro's Water Resources Department. Specimens ranged from 124–148 mm TL. The specimens were found in slackwater pools and along the stream margins associated with silt, sand, and small woody debris. The Varnals and Haw creek sites are within 2.6 miles of one another, but the site on South Buffalo Creek is approximately 50–60 stream miles upstream. Separating the lower two sites from the upper site are four dams; it is thus likely that the three specimens represent two widely separated introductions. It is not known if the species is established at any of the sites or is found at other sites within the Haw River system. Future surveys are necessary to determine if the species is established at these locales and is dispersing into new streams throughout the upper Haw River subsystem.

Michael Fisk (North Carolina State University) has completed his MS thesis on the effects of regulated flows on habitat ecology of the Robust Redhorse in the Pee Dee drainage. The objectives of his study were to describe habitat suitability, quantify suitable habitat before and after the implementation of a new minimum flow regime, describe habitat use, and assess egg and larval survival associated with flow augmentation. Michael implanted adult Robust Redhorse with radio-transmitters and relocated fish from February 2008 to July 2009. Non-spawning habitat consisted of deep, slow-moving pools with bedrock and sand substrates with boulders or coarse woody debris cover. Spawning habitat consisted of shallower, faster-moving water with gravel and cobble substrate associated with shoals. Except for spawning and post-spawning migrations, Robust Redhorse were generally sedentary making only localized movements. After spawning, a group of fish migrated downstream into the Coastal Plain, while other

fish stayed in the Piedmont in close proximity to spawning grounds. Habitat suitability indices were developed based on field microhabitat measurements and applied to model weighted usable area (suitable habitat quantity) for proposed minimum flows. Weighted usable area increased for each seasonal minimum flow for both spawning and non-spawning periods. A laboratory experiment was conducted to assess the effects of flow regime and redd dewatering on eggs and larvae. Eggs were able to withstand some degree of dewatering, but once larvae hatched dewatering was fatal. Hydroelectric facilities can use these results to manage river flow more effectively and create and maintain important aquatic habitats during critical time periods for species of concern.

Five fish re-introduction projects are underway in North Carolina. As part of the FERC relicensing for Roanoke Rapids and Gaston dams on the lower Roanoke River, Dominion Generation was required to install fish passage structures for American Eels at Roanoke Rapids Dam by 2010. Two eelways have been completed. A 24 ft long eelway attached on the south side of the dam with a 45° angle was operational on March 1 while the longer 105 ft eelway on the north side was operational April 5. These eelways have proved to be exceedingly successful. As of June 24, an estimated 292,329 American Eels have climbed the eelways into the capture buckets. The south and shorter eelway has accounted for 89% of the captures. Over 41% of the eels moved up the eelways in early to mid-April. Eels have been subsequently released into Roanoke Rapids Lake or Deep Creek, a primary tributary of the lake. Sampling was initiated at the base of Gaston Dam to measure the upstream movements of the eels. Once a sufficient number is captured, then eelways will be built at this dam.—*Mark Cantrell*

Richland Creek (in the Pigeon River drainage of Haywood Co.) is on North Carolina's §303 (d) list of impaired waters due to historic and long-term poor water quality, hydrologic modifications, and habitat degradation. While recent watershed enhancement projects upstream from Lake Junaluska have resulted in improvements in water quality, the dam acts as a barrier to upstream fish recolonization and migration. To restore the biological integrity of the fish community, a multi-partner reintroduction project began in April 2010 funded in part by the American Recovery and Reinvestment Act. This project is a cooperative effort among the NCDWQ, NCWRC, Haywood Waterways Association, and the University of Tennessee-Knoxville, which involves the collection, transport and release of fish of several species twice a year for three years or until the species establish reproducing populations. In April 2010, almost 2,500 fish representing seven species (Warpaint Shiner, River Chub, Mottled Sculpin, Rock Bass, Fantail Darter, Greenfin Darter, and

Tuckasegee Darter) were released upstream from Lake Junaluska. For a podcast of the project, please click on: http://www.fws.gov/asheville/htmls/podcast_transcripts/Richland-Creek.html.

From 2007 thru 2009, Pat Rakes, J. R. Shute, and staff of Conservation Fisheries, Inc. (CFI) working with Steve Fraley and Thomas Russ with the NCWRC and Mike Lavoie of the Eastern Band of the Cherokee Indians have released approximately 3,000 juvenile Sicklefin Redhorse into the Oconaluftee River and approximately 2,000 juveniles into the Tuckasegee River near Cullowhee. For 2010, rearing and stocking was suspended to re-evaluate the program and concentrate on monitoring restoration streams. An initial August snorkel survey failed to locate any stocked fish but additional efforts are planned for this fall.

Steve Fraley with the NCWRC and Joyce Coombs with UT-Knoxville report that in 2009 and Spring of 2010, 2,064 Tennessee Shiner, 668 Mirror Shiner, 474 Silver Shiner, 448 Telescope Shiner, 403 Gilt Darter, 314 Highland Shiner, 183 Banded Darter, and 16 Bigeye Chub were translocated from various source populations elsewhere in the French Broad River system to the Pigeon River in North Carolina. Monitoring surveys continued to find Telescope Shiner in good numbers and multiple year classes over 10 miles of the target reach. Silver Shiners are occupying the same reach, and observations in 2010 suggest dispersal upstream. Translocations of both species ceased in 2009. Tennessee Shiner appear to be well on their way to recovery, however, little evidence of recovery has been seen for Gilt Darter, of which 819 have been released since 2005. The Pigeon River was severely polluted for most of the 20th century until improvements in wastewater treatment were made at a paper mill in Canton in the late 1980's & 1990's. Partners include UT-Knoxville, NC Wildlife Resources Commission, NCDWQ, Evergreen Paper Company, and U.S. F&WS.

Steve also reports that in June 2009 and 2010, 1,450 Spotfin Chubs were released in the recently re-watered Cheoah River in NCWRC's efforts to restore the river's native fauna. Survey results from July 2010 were encouraging with one large adult from the 2009 release and eight age-1 fish from the 2010 release seen. Additionally, five Wounded Darters were seen: three released in 2009 and two released in 2008 by CFI. Both species were propagated at CFI from brood stock collected from the Little Tennessee River. Spotfin Chub are reared for 10 months at NCWRC's Conservation Aquaculture Center at Marion State Fish Hatchery before release. Partners include U.S. F&WS, CFI, U.S. Forest Service, and Alcoa Power.

Lastly, Steve reports that in late 2009 field season, surveys for 16 fishes identified as priority species in the North Carolina Wildlife Action Plan were completed at 38 sites in the Little Tennessee and Hiwassee River systems.

Cooperators (NCDWQ, Tennessee Valley Authority, Little Tennessee Watershed Association, and the NCWRC Brook Trout Project) provided data from another 70 sites. Similar surveys were completed for nine priority species in the Broad and Savannah River systems in early 2010 field season. All data are or will be incorporated into the NCWRC Aquatics Database and will be used to assess and track status of priority species. One focus in the Little Tennessee and Hiwassee systems was on the undescribed "Smoky Dace" (*Clinostomus* sp. cf. *funduloides*).

Two dams have been removed in recent years in North Carolina. Dave Coughlan and Hugh Barwick, Duke Energy, report that the Dillsboro Dam and associated powerhouse on the Tuckasegee River in Jackson Co., Little Tennessee River system, were removed in February-March 2010 as a result of relicensing activities associated with Duke's Nantahala Area Hydroelectric Projects. The dam and powerhouse was constructed in 1913 and operated until 2004. 58,000 cubic yards of sediment had to be removed from the reservoir upstream of dam prior to demolition to protect downstream populations of the endangered Appalachian elktoe mussel. Responses of biotic communities to the removal were assessed by Duke Energy personnel, who sampled macroinvertebrate and fish communities biannually in the river for one year prior to and will continue sampling three years subsequent to dam removal. For a podcast of the project, please click on: (http://www.fws.gov/asheville/htmls/podcast_transcripts/Dillsboro_dam_removal.html). In summer 2009, the Steels Mill Dam on Hitchcock Creek near Rockingham in the Pee Dee drainage was removed. Post dam removal surveys are being conducted by the Catena Group through funding by American Rivers.

From the North Carolina State Museum of Natural Sciences, Wayne Starnes reports that great progress has been made on the ongoing project of databasing the fishes and aquatic invertebrates collections and making them web accessible. SFC members are invited to visit NCSM's collections website at: <http://collections.naturalsciences.org>. This effort has been facilitated in a large part by two grant awards from NSF and two years of funding to the Fishes Unit from the NCWRC as well as some NCWRC support to the Mollusk Unit. NCSM currently has an estimated 110,000+ lots of fishes of which nearly 59,000 are now databased, completely georeferenced, and web accessible. These efforts have been organized by collection manager Gabriela Hogue with able assistance of technicians Jimmy Chang, Maridith Gatens, and Chris Gannon and some volunteers. Bryn Tracy of the NCDWQ has come on part-time to mightily help Wayne with verifications of species identifications. The geographic scope of the collection is extensive, with representation from across the U.S. and nearly 40 foreign countries, but the heaviest emphasis is on the mid Atlantic states and Southeast freshwater fauna and the

South Atlantic Bight marine assemblage, including quite a lot of deep water material. In addition to keeping abreast of the steady stream of new accessions, efforts continue to incorporate older backlogs from various orphaned collections, including Duke University, UNC Institute of Marine Sciences, Western Carolina University, Mars Hill College, North Carolina State University, Stockton State University (NJ), the W.C. Starnes collection, and several others. Parallel efforts have been made on the aquatic invertebrates collections in the last couple years, including the extremely valuable collection of Herbert Athearn that was recently accessioned at NCSM and which contained a large number of species that are now extinct or severely imperiled.

In the Fishes Unit, some especially notable accomplishments have occurred in the last couple years. The collections from the NCWRC's statewide basin surveys of the early 1960s are now completely processed and databased. These had languished at NCSM in various states of curation, from fully cataloged to totally unsorted, for several decades. Quite a few SFC members may be familiar with the series of 23 basin reports the NCWRC published in the 1960s based on results of these surveys. All collections data from those reports have been entered into a database at NCSM and the aim is to produce comparative listings of the content of those reports with the actual data obtained from the voucher collections. That compendium should be produced early in 2011. Another particular accomplishment was the completion of the re-curation and databasing of all of NCSM's large specimen holdings, including over 750 glass crocks, 66 coffins, and several large vats.

While lab director duties and committee work with NCSM's new Nature Research Center have been a significant incursion on Wayne's time for curatorial- and research-related activities, he and the NCSM Fishes Unit staff are managing to participate in a few other activities. One of the chief of these is a survey for the apparently rapidly disappearing Bridle Shiner throughout eastern Virginia funded by the Virginia Division of Game and Inland Fisheries (see Virginia report). They are also collaborating with biologists from the NCSU Cooperative Fish & Wildlife Unit on studies of amphidromous freshwater gobies throughout Puerto Rico, including molecular studies to discover the amount of polytypy in those populations, gene flow patterns among drainages, and patterns of species' distributions within and among drainages. Closer to home, Wayne and Morgan Raley, juggled with Morgan and Art Bogan's genetic studies of Atlantic Slope unionid mollusks, continue genetic and population status survey work on the undescribed Carolina Redhorse as time allows and also continue to cooperate with the Robust Redhorse Conservation Committee's efforts. Miscellaneous studies, mostly still in materials gathering stages, include investigations of genetic and morphological complexities in

southern populations of the Johnny/Tessellated darter group, southern Swallowtail Shiner populations, shiners of subgenus *Hydrophlox* (with Mollie Cashner), and an intriguing study of some dwarfed and morphologically ambiguous herrings (*Alosa* spp.) in some NC reservoirs.—

Bryn Tracy

OKLAHOMA

D.B. Fenner, K. Collins, B. Bristow, R. Standage, and R. Bastarache are conducting annual surveys to monitor the status of the federally Threatened Leopard Darter in southeastern Oklahoma and southwestern Arkansas. Information from the monitoring effort, which began in 1998, has been used to evaluate the species status as threatened and guide recovery actions for the species. Although 2010 surveys observed an increase in overall darter numbers, long term analysis suggests populations trends are stable to declining. The Leopard Darter has not been observed from the Robinson Fork of the Rolling Fork River since 2005.

A. A. Echelle, W. L. Fisher, and R. A. Van Den Bussche continue to investigate levels of genetic divergence between populations of various species (Rocky Shiner, Redspot Chub, Logperch, and Least Darter) in the Ozark/Ouachita region and populations in Blue River, southcentral Oklahoma. The purpose is to help evaluate the evolutionary distinctiveness of the Blue River ichthyofauna in response to conservation concerns generated by potential overmining of the Arbuckle-Simpson aquifer in southcentral Oklahoma. Funded by the U.S. Fish and Wildlife Service and the Nature Conservancy of Oklahoma.

A. A. Echelle, W. L. Fisher, and R. A. Van Den Bussche also continue to study geographic variation in genetic structure of the Leopard Darter, a federally threatened species endemic to the Ouachita Mountains of southeastern Oklahoma and southwestern Arkansas. The purpose is to provide baseline data on levels and pattern of genetic diversity as a benchmark for future management of the species. Funded by the U.S. Forest Service (Hot Springs, AR).

J.M. Long and D. Turton are studying the effects of flow on native fish species in Lee Creek, Oklahoma, with particular attention to effects on Longnose Darter, a state endangered species. Lee Creek is one of six state scenic rivers in Oklahoma and is the only stream remaining in Oklahoma that harbors Longnose Darters, but a dam is being proposed for construction in its headwaters.—*David Martinez*

SOUTH CAROLINA

Jeff Foltz's (Clemson University) lab continues to study the population of Turquoise Darters that was established in Six Mile Creek within the Clemson Experimental

Forest. Estimates from 2008 indicate an average darter density of 0.37 darters per square meter of riffle and that every riffle in the Clemson Forest has darters residing on them. Additional stockings have occurred recently to increase genetic diversity.

Bert Ely's group at the University of South Carolina has evaluated the evolution of an MHC class Ia gene fragment in North American *Morone* species; detecting high levels of polymorphism in Striped Bass, White Perch and Yellow Bass, but extremely low levels of MHC diversity in White Bass, suggesting the possibility of a severe population bottleneck for this species. Joe Quattro's lab is working on hybridization among black bass introductions in the Savannah and Santee rivers with an emphasis on hybridization/introgression with Redeye Bass. As part of this, they have started some historical work on interrelationships between the Savannah, Santee and French Broad fishes, particularly minnows, to look at when transfers might have occurred and the direction – ultimately to determine if the Santee River Redeye Bass are native or introduced.

SCDNR's Diadromous Fishes Program (Bill Post) has ongoing research evaluating Atlantic and Shortnose Sturgeon, American Shad, and American Eel. These studies include a multi-state sturgeon grant to delineate migration patterns of both species, an American Shad stock enhancement program in the Edisto River, SC, a study assessing adult and juvenile American Shad spawning behavior and recruitment in the Santee-Cooper System, and a project constructing of an eel ladder at Goose Creek Reservoir, SC to restore eel passage to important eel maturation habitat.

SC DNR's Freshwater Fish Section (Scott Lamprecht) has completed its 6th year of a Robust Redhorse restoration project in the Santee River system. Gravid individuals have exhibited spawning migrations/behavior and a number of individuals have used the Columbia fish ladder with tagged redhorse making migrations in excess of 200 km. Striped Bass recruitment in Santee Cooper Reservoir continues to be an area of study; particularly primary productivity and its relationship to flows, interactions of juvenile life stages of Striped Bass, Blueback Herring, American Shad and White Perch, and the role of exotic organisms (*Corbicula*) and system productivity. The SCDNR Stream Assessment Team (Kevin Kuback) is busy collecting fish, habitat, and water quality data in the Broad River basin that will be used in a decision support system for watershed conservation. A long-term study assessing the effects of dam removal on Twelvemile Creek in the upper Savannah River basin is ongoing (Mark Scott). Fishes were collected over the summer and fall as sediment behind the dam is being dredged and removed from the channel. Additional monitoring in collaboration with Clemson University focuses on water chemistry, channel geomorphology, and aquatic macroinvertebrates.

SCDNR's Estuarine Finfish Section (Tanya Darden) continues to contribute genetic aspects to DNR's American Shad project in the Edisto River and Striped Bass research within the Santee Cooper system. Additionally, we are working on the development of an aging tool for Shortnose and Atlantic Sturgeon based on telomere length and are in our fourth year of an experimental restoration study of Striped Bass within the Ashley River system.—*Tanya Darden*

TENNESSEE

During an October 2010 Tennessee Valley Authority (TVA) electrofishing sample in Pickwick Reservoir inflow area downstream of Wilson Dam (RM 259), a Blue Sucker was collected. This species has not been encountered in biannual TVA fish sampling at this site since 1994, when two individuals were collected. Furthermore, Blue Suckers have not been encountered at any other location in the mainstem Tennessee River during TVA fish sampling conducted during the past 20 years. However, Blue Suckers have been collected on a frequent basis in Barkley Reservoir from 2002 to 2010 in TVA gill net samples (Cumberland River Miles 99 to 107). During most years, only one individual was collected. During 2009, 6 individuals were collected at Cumberland River mile 107.—*Jeff Simmons*

TVA's routine IBI monitoring continues to produce noteworthy records: Six adult Snail Darters were found on the Sequatchie River at Nickletown (RM 7.1) in Marion Co. TN. A small population is known to exist in the lower Sequatchie River, but this was the most ever seen during routine TVA monitoring which is conducted there on an every other year basis.

On the Elk River (RM 31) at Mason Island, just downstream from the state line in Tennessee, one adult Boulder Darter and several juveniles were observed and released. Also, during a boatshocking run in a deep pool, a very large Asian carp was observed leaping high from the water alongside the boat, but eluded capture. The placement of the eye and the mottled pigment pattern on the body lead us to believe that it was *Hypophthalmichthys molitrix*.

Further upstream on the Elk River (RM 130.8), just below Tims Ford Dam, native fish species diversity has improved from 13 taxa in 2008, to 23 taxa in 2010.

The Duck River continues to produce tremendous aquatic diversity. TVA samples there turned up healthy numbers of Coppercheek Darter, as well as a few Ashy Darter, Saddled Madtom, and Striated Darter at several sites. We counted 28 individual Striated Darters at one site in the mainstem of the Duck River (DRM 48) near Hwy 231, which was surprising considering they are usually found in low numbers in smaller tributaries to the middle Duck River system.—*Amy Wales*

The Cherokee National Forest, Tennessee Wildlife Resources Agency, and the Tennessee Council of Trout Unlimited are starting a major effort for Brook Trout restoration. This colorful native of the Southern Appalachian Mountains is largely confined to minor headwater tributaries and is being extirpated by climatic changes. Competition from introduced Rainbow and Brown Trout prevents Brook Trout from reclaiming larger, downstream waters less affected by water temperature and flow changes. The first phase of this recovery effort is to renovate a hatchery building at the TWRA Tellico Fish Hatchery on the Tellico River. This facility will be capable of producing 2,000 to 10,000 fry per year once it reaches full operational capacity. Only southern strain Brook Trout will be produced and each fifth level watershed (i.e. Little Tennessee, French Broad, Nolichucky) will be treated independently to retain maximum genetic isolation. Rainbow and/or Brown Trout will be removed from selected streams using rotenone. Log barriers may be constructed to prevent non-indigenous fish from re-invading the designated Brook Trout water. Other native fish species present at the time of renovation or species known to have occurred in the treated reach will be re-introduced and their populations will be maintained.—*Jim Herring*

Tennessee Aquarium Conservation Institute (TNACI) reports that more than 90,000 Lake Sturgeon have been reintroduced in the upper Tennessee River over the past 10 years, and releases have started in the Cumberland River as well. The Barrens Topminnow propagation program continues, and the Aquarium opened a new interactive exhibit dedicated to this effort last year. TNACI and CFI began a new propagation and genetics program for Conasauga Logperch; CFI is currently holding 10 in captivity from collecting efforts in 2009 and 2010. TNACI and Appalachian State University continue quarterly sampling of Watts Bar Reservoir to monitor the impact of the coal ash spill on the fish community for both species composition and toxicology studies.—*Anna George*

Pigeon River Recovery Project (2010): Spring 2010 fieldwork began in April in TN with the first attempt to collect Wounded Darters from the Little River for re-introduction or propagation. After many efforts, two males were collected and released. Candidate status will be re-evaluated. The Little Pigeon River was visited in June to collect Stripetail Darters for their new release site (RM 13.7). A long day's effort only netted 14 individuals, a new low. What we observed was a change in aquatic habitat from a dominance of clean cobble to a dominance of sand/silt and aquatic vegetation. Few Gilt Darters were collected (3), therefore, our genetic sampling has been put on hold for the Little Pigeon population. Low numbers of all other darter species were observed as well. Our Spring collection efforts concentrated on the French Broad at Campbell

Island, while Fall efforts zeroed in on the Nolichucky as flows were very low. East Tennessee has experienced near-drought conditions from July - October. Total numbers released this year are as follows: 120 Bluebreast Darter, 19 River Chubs (augmenting existing population), 296 Mountain Madtoms, 14 Stripetail Darters and 3,254 common river snails (*Pleurocera/Lithasia/Leptoxis* spp.). All species except the Mountain Madtom were released at the new site at RM 13.7, the mouth of Cosby Creek.

Monitoring efforts began with a joint IBI survey conducted by TVA, TDEC and UT on the lower Pigeon at Fork Island, RM 0.5 (the last IBI was in 1989). Good habitat but low numbers of intolerant species and high numbers of omnivores produced an IBI score of 42 – which included a Gilt Darter. Annual IBI surveys were conducted in July and found no re-introduced fish species and low numbers of snails at Denton. Tannery Island IBI results shows continued support for populations of Gilt Darters, Mountain Madtoms, Stripetail Darters, many common snails and the Spiny River Snail. A complete snorkel survey of all Pigeon River sites (32) was initiated in 2006 and completed in 2007. Good numbers of Gilt Darters were observed at 18 sites, as well as Bluebreast Darters, Mountain Madtoms, Blotched Chub and Mountain Brook Lamprey at their re-introduction sites. In 2009, we began a snorkel survey to determine the effects of 2 years ('07,'08) of drought, if any. The rains cut the survey short at 3 sites and we had found only 1 Gilt Darter. The remaining sites (32), including 3 new sites, were surveyed in 2010, with the lower sites (7) not observed until October (water temp 61 F). We located one-third as many fish as 06/07 but they were found in the best available habitat and had expanded their migrations to new sites.—*Jonathon Burr & Joyce Coombs*

Conservation Fisheries, Inc. continues to propagate, stock, and monitor Smoky and Yellowfin Madtoms, Citico Darters, and Spotfin Chubs in Tellico River, with reproduction and good numbers noted there for all four species again in 2010. Monitoring of Citico Creek and Little Tennessee River source populations detected no significant population changes. Fin clip tissues are being collected from Citico and Abrams Creek fish for population genetics comparisons of the madtoms and darter by Greg Moyer at Warm Spring NFH. TTU students continue to study the Abrams Creek populations' distribution, abundance, habitat associations, etc. Efforts to propagate and restore Emory River Spotfin Chubs and Elk River Boulder Darters to Shoal Creek continue, with stockings of both species at numerous sites above Iron City via canoe. Wild-spawned Boulder Darters were observed 3 miles downstream of stocking sites—the first evidence of dispersal. Monitoring will need to be extended into Alabama next year. Hatchery spawning and rearing included the following additional species/populations in 2010: Marbled Darter, Blotchside

Logperch, Barrens Topminnow, Wounded Darter, Ashy Darter, Copper Creek and Powell River Yellowfin Madtoms, Spring Pygmy Sunfish, Rush Darter, Kentucky Arrow Darter, Cumberland Darter, upper Allegheny R (PA) Gilt Darters, and Diamond Darters (though none of the huge-gaped toothy larvae of the latter survived past yolk-sack absorption). The 3 Conasauga Logperch collected in 2009 did not spawn, but 8 additional individuals were collected in August (in a record 13+ *Percina jenkinsi* day!) to add to the 2011 breeding population for the effort to develop propagation protocols and study possible mate selection with tagged and genetically typed fish (with TNACI). CFT's website provides additional information, along with photos and video (www.conservationfisheries.org), PLUS there's lot's of stuff on a new FaceBook page (<http://www.facebook.com/pages/Conservation-Fisheries/377299094501>).—*Pat Rakes*

Jennifer Joice has finished entering in all 36,000 lots of the University of Tennessee Etnier Ichthyology Collection (UTEIC) into a Filemaker database, has started getting GPS information for all collection localities, and the collection has a shell of a website: <http://www.bio.utk.edu/hulseylab/form.html>.—*Darrin Hulsey*

During June 2009, a crayfish belonging to the currently monotypic genus *Barbicambarus*, was collected from Factory Creek, a tributary to Shoal Creek in Lawrence Co., Tennessee during TVA stream sampling. Lawrence Co. is located in south-central Tennessee; Shoal Creek drains south into Alabama and enters the Tennessee River at Wilson Reservoir. *Barbicambarus cornutus* is endemic to the Green River system of north-central Tennessee and west-central Kentucky. When we pulled the seine, [Simmons] knew immediately that the animal was a *Barbicambarus* and thought, "What idiot drove this thing all the way down here from Kentucky and let it go!?" After further examination and additional collecting by Guenter Schuster and Chris Taylor, it was determined that this was a new species! Only five individuals are currently known to science. Considerable additional effort in the Shoal Creek system has not produced additional specimens. This species may be one of the rarest crayfish in Tennessee. The species description is in press (Schuster and Taylor) and should be in print early 2011.—*Jeff Simmons*

TEXAS

The Edwards Aquifer Recovery Implementation Program (EARIP), a stakeholder-driven process created to evaluate water usage throughout the Edwards Aquifer and determine the best way to regulate this usage and protect the eight listed species, is close to developing a Habitat Conservation Plan, and ameliorating the water wars in central Texas.

The Texas Fish and Wildlife Conservation Office is currently working with the Texas Parks and Wildlife Department, United States Geological Survey, the Caddo Lake Institute and others to study the feasibility of reintroducing Paddlefish into Big Cypress Bayou and Caddo Lake. Texas Senate Bill 3, which called for the release of waters from impoundments for the benefit of fish and wildlife, has led water managers to begin the process of creating more natural flow regimes in the state. Once a more natural flow regime is in place, Paddlefish will be restocked into the Big Cypress Bayou and a movement and migration study will evaluate the success of stocking strategies and the effects of the flow regime on habitat and Paddlefish fidelity to their drainage.

Raelynn Daeton (Sam Houston State University) has been focusing conservation efforts on the genus *Gambusia*. Several species are endemic to this region, some are endangered and others highly invasive. With TPWD and USFWS, Dr. Daeton and her graduate students are examining life history evolution (reproductive strategies directly influencing fitness), parasite-host interactions, population ecology, social network theory, genital divergence, behavioral differences across isolated populations, speciation, population genetics, mating behaviors, potential hybridization between species, fluctuating asymmetry as an indicator of male quality, and predator-prey interactions (focusing on piscivorous fishes and snake predators). USFWS employees are also involved in determining microhabitat use in the Clear Creek *Gambusia* (San Saba River drainage), represented by a single remaining population.

A series of habitat studies in the endangered Fountain Darter were completed or are in progress by USFWS and Texas State University including examining movement patterns, determining sites of egg deposition in the wild, evaluating population genetics and recent bottlenecks, and evaluating recovery following the recent exceptional drought.—*Catherine Phillips*

VIRGINIA

Wayne Starnes (NC Museum of Natural Sciences) reports that he and various of his staff, with help from VDGIF biologists and others, are conducting surveys for the apparently disappearing Bridle Shiner over a broad area of eastern Virginia during the 2010 and 2011 field seasons. This effort is funded by the VDGIF. Plans are to survey over 130 sites, including all sites known to previously harbor the species, plus many additional exploratory sites in coastal plain and lower piedmont portions of the Potomac, Rappahannock, York, James, and Chowan basins that lie within the former overall range of the species and that afford habitat characteristics similar to those of known Bridle Shiner locales in Virginia and other states

based on the experience of the collectors. On the coastal plain, preferred habitat types of this species can be especially difficult to collect effectively. For the nearly 40 sites surveyed thus far, the picture has not been rosy, with only one extant population (from a previously unknown locale in the lower James) discovered. However there is much work left to be done, including in some portions of the lower James/Chickahominy area which may hold at least some promise of persistent populations. Any populations discovered will be compared genetically with one another and extralimital populations to assess phylogeographic patterns, discover possible ESUs, and, if numbers allow, determine effective population sizes.

Chas. Gowan is a trout biologist conducting research on a variety of topics related to Brook Trout, including the efficacy of habitat manipulation for increasing population abundance in small streams, the causes and consequences of fish movement at the reach scale (100s to 1000s of meters), and the mechanisms individual trout use to select foraging locations. His most recent research focuses on how individual trout form dominance hierarchies, including the role of individual recognition and transitive inference (a process whereby a bystander learns its place in the dominance hierarchy by watching other fish fight) in the establishment and maintenance of hierarchies. Gowan is the Paul H. Wornom Professor of Biology at Randolph-Macon College in Ashland.

Jamie Roberts and his PhD advisors Paul Angermeier and Eric Hallerman at Virginia Tech recently completed population genetic studies on endangered Roanoke Logperch using microsatellite and mtDNA markers. Results indicate dramatic variation in effective population size and genetic diversity across seven extant, isolated populations. Logperch propagation techniques have been developed by CFL, so with these genetic data in hand, it may now be feasible to begin logperch introduction/translocation activities. Roberts and Angermeier recently completed the 13th year of fish assemblage sampling on the upper Roanoke River. Analyses of these data should provide insight into the effects of urbanization on fish demography and assemblage dynamics. Planned upcoming research projects include development of probabilistic sampling techniques for estimating abundance and distribution of Roanoke Logperch populations, as well as distributional surveys for logperch in poorly-surveyed portions of the Dan River watershed in Virginia.

Steve Powers completed his second year as Bob Jenkins' successor at Roanoke College and continues to work on updating the RC fish collection. Analyses of mitochondrial DNA data from Ashy Darter, including specimens from the newly rediscovered population in the Elk River, TN, are near completion, as are systematic studies of the complex. Life-history research on several Virginia species

is also underway in collaboration with RC students.—*Steve Powers*

WEST VIRGINIA

Barb Douglas (Senior Endangered Species Biologist, U.S. Fish and Wildlife Service, Elkins, WV) reported the following news regarding the Diamond Darter: In November 2009 the diamond darter was identified as a candidate for potential addition to the list of threatened and endangered species protected by the Endangered Species Act. In April 2010, the Center for Biological Diversity and a coalition of other environmental organizations petitioned the USFWS to list the Crystal Darter and 403 other species as threatened or endangered under the ESA. The petition did not differentiate between the Diamond darter and the Crystal darter and included information on the threats to the Diamond Darter and its current range in WV as part of the justification for potential listing [despite input from SFC (Ed.)]. The USFWS has not yet responded to that petition. As a separate and independent action, the USFWS's West Virginia Field Office has been given approval to proceed with developing a draft package to formally list the Diamond Darter as endangered. It is anticipated that a notice in the Federal Register and request for public comment will be published late in 2011. Threats to the species are continuing and increasing and include increased gas

well development in the Elk River watershed, a sewage line break into the Elk River near Clendenin, and proposals for a bridge crossing and a water line crossing within one of the shoals known to support the species. The USFWS is currently working with others to avoid and minimize the impacts of these actions.

Link to 11/09 candidate notice of review: <http://www.fws.gov/endangered/esa-library/pdf/CNOR%2011-9-09.pdf>

Link to 04/10 CBD petition: http://www.biologicaldiversity.org/programs/biodiversity/1000_species/the_southeast_freshwater_extinction_crisis/pdfs/SE_Petition.pdf

Further news regarding the Diamond Darter involves recent research at Conservation Fisheries, Inc., Knoxville, TN. Captive propagation of the Diamond Darter is a component of graduate research by Crystal Ruble (hatchery manager, CFI). Captive propagation of this species was partially successful during 2010, and this work is summarized on the CFI webpage.

The proceedings of a 2008 crayfish symposium (southern Division AFS, Wheeling, WV) were published in a 2010 Special Issue of the *Southeastern Naturalist*. The proceedings include 17 papers, with several papers relevant to West Virginia.—*Stuart Welsh*

Business Meeting 35th Annual Meeting Southeastern Fishes Council November 12th & 13th, 2009 Guntersville State Park, AL

The 2009 business meeting of the Southeastern Fishes Council was called to order by Chair Bernie Kuhajda at 4:43 p.m. Eighty-nine people were in attendance.

Secretary's Report

Rebecca Blanton announced that minutes from the 2008 business meeting were approved unanimously and posted on the SFC website. Twenty-nine members submitted votes by email.

Treasurer's Report

Treasurer Anna George presented SFC's financial standing, noting that membership growth had led to an increase in the society's budget. She reported that the starting balance as of 1 January 2009 was \$17,386.53 and at the time of the meeting was \$30,524.07. She noted that this amount did not include deductions or revenues associated with the 2009 meeting or the mailing and printing of the 2009 Proceedings.

Treasurer George supplied the membership with a summary of the 2009 meeting cost reporting the following: In 2009, registration payments were \$8730 with an additional \$1850 from the World Wildlife Fund. Coffee mug sales were estimated at \$900 resulting in a total meeting revenue of \$11,480. Treasurer George indicated that presently, approximately \$5,048.72 had been spent on meeting costs indicating an overall profit for 2009.

Treasurer George thanked the World Wildlife Fund for their continued financial support.

Committee Reports

Program & Meeting Site Committee – Jim Williams and Anna George

Jim Williams presented information on the geographic location of the majority of the membership and discussed the committee's desire to continue to hold annual meetings at venues as centrally located as possible. He presented a map of member zip codes that illustrated the central location of the geographic distribution of members was very close to Guntersville, AL.

Williams also announced that the location of the 2010 annual meeting would be held in Athens, GA on the 11th and 12th November. He and Mary Freeman agreed to serve as co-Chairs for its planning. He reminded the membership that in 2011 we would return to Chattanooga, TN. David Etnier asked if a meeting location had been chosen in Athens. Mary Freeman responded that it would be at Convention Center in downtown Athens.

Anna George agreed to serve as chair of the meeting site committee for the 2011 meeting in Chattanooga, but requested someone volunteer to serve as co-Chair. Williams polled the membership for their opinion of the state park as a meeting site; the majority of the members were pleased with the location and facilities. He indicated that we would likely use their facilities again in the future.

Constitution Committee

Chair Kuhajda announced that the Constitution Committee proposed that three new committees, the Membership Committee, the Website Committee, and the Meeting Site Committee, be officially incorporated into the society's constitution. He indicated that the society had approved these committees in 2006, but they were never incorporated into the constitution. He called for a vote to incorporate them into the constitution; the membership agreed unanimously to accept this action.

Resolution Committee – nothing reported.

Proceedings Committee – Editor, Marty O'Connell; Associate Editor, Chris Skelton

Editor O'Connell told the membership that he had hoped to have the 2009 Proceedings out prior to the meeting, but noted the large size of the 2009 issue. Brett Albanese asked if state reports would continue to be included in the printed copy of the Proceedings only or if these could also be posted on the website. The membership discussed these alternatives and agreed to post them on the SFC website.

Awards Committee – Gerry Dinkins and Anna George

Dinkins presented the "Most Fecund" award to Ginny Adams (University of Central Arkansas) for bringing the most students to the meeting and the "Most Vagile" award to Noah Greenwald for the greatest distance traveled to

attend the meeting. George presented gifts to the outgoing Chair, Bernie Kuhajda and outgoing Editor, Marty O'Connell to express the society's appreciation of their service.

Technical Advisory Committee – nothing reported

Membership Committee – *Rebecca Blanton Johansen*

Rebecca Blanton provided a summary of the overall membership for the society for 2007-2009 and presented the following to those attending the business meeting:

2009: 167 total members (institutional and individual) including:

4 life members (2%)

119 regular members (71%)

Includes 2 library (1%) and 4 (2%) family memberships

44 student members (27%)

2008: 192 total members (institutional and individual) including:

- 4 life members (2% of membership)

- 129 regular members (67%)

- 59 student members (31%)

2007: Total of 79 members (institutional and individual) including:

- 4 life members (5% of membership)

- 64 regular members (81%)

- 11 student members (14%)

She noted that the 2009 numbers did not reflect new or renewed memberships paid at the time of the meeting.

Website Committee – *Jake Schaefer and Noel Burkhead*

Jake Schaefer asked for volunteers to assist in helping with revisions of the new website and asked that anyone interested in helping contact him. He also announced the new website address: <http://ichthyology.usm.edu/sfc/>.

Nominating Committee – *Gerry Dinkins*

Dinkins announced nominations for the new editor of the Proceedings included David Neely and the nominations for Chair Elect included Carol Johnston and David Eisenhour. He also indicated that Rebecca Blanton and Anna George had agreed to serve another term in their current positions as Secretary and Treasurer, respectively. Chair Kuhajda asked if there were other nominations for these positions. No other nominations were made. Chair Kuhajda called for a vote to close nominations, the society agreed unanimously.

Election of Officers

Chair Kuhajda put forth a motion to keep George and Blanton in their current positions and to elect Neely as the new editor. The motion passed unanimously.

Gerry Dinkins presented background information on the two candidates for new Chair-elect, David Eisenhour (Morehead State University) and Carol Johnston (Auburn University) and opened the floor for other nominations. No other nominations were made, he moved to close the floor, and the membership agreed to do so unanimously. Carol Johnston was elected as the new Chair-elect.

Old Business

1. Status of Electronic Only Proceedings

Chair Kuhajda opened the floor for further discussion of converting the Proceedings to an electronic only format. Mel Warren proposed that if we did not want to go entirely to an electronic only format, that removing the state reports from the printed version and publishing those electronically would help reduce cost and paper usage. Jim Williams supported the idea of only publishing the state reports electronically, but said that he would like to see the Proceedings remain in a paper format or at least retain the option of a paper copy.

Brett Albanese also supported the idea of moving the state reports to an electronic format arguing that in their current state they are not dynamic; Anna George said this was because much of what is submitted gets cut to conserve space and reduce costs. She argued that if they were published on the web, more information and the fun aspects of work going on in various states could be reported.

Chris Skelton asked for volunteers to take over as assistant editor of the Proceedings and asked that anyone interested contact him to discuss obligations of this position.

Chris also noted that one benefit of having the Proceedings available electronically would be that they could be included in searchable databases. However, he and Anna noted that the cost of having the Proceedings available through BioOne was too expensive. Skelton asked if once the Proceedings were uploaded to the SFC website if they were available to everyone or just current SFC members. Chair Kuhajda said that those more than a year old were accessible by all; others require a password to access, which is given to current SFC members. Jake Schaefer pointed out that the older Proceedings were scanned copies and thus not searchable documents, but newer ones were posted as pdf documents and would be searchable. Wayne Starnes asked how the format of the Proceedings related to library distribution. Chair Kuhajda replied that having the journal in an electronic format and included in some type of searchable database would certainly increase its legitimacy and likely lead to more library circulation.

2. Formal Partnership with SARP:

The membership briefly revisited the decision to form a formal partnership with SARP. The decision was made to have one or more SFC representatives attend and help guide decisions and plans generated by the SARP Imperiled Fishes and Aquatic Species Recovery Workgroup. At the time of the meeting, a representative had not been selected.

3. State reports to replace regional reports:

Chair Kuhajda noted that this action required a constitutional change, which was previously completed and that state reports, rather than regional reports, would be the standard format used going forward.

New Business**1. List of Southeastern fishes now posted on SFC webpage:**

Chair Kuhajda announced that a list of Southeastern fishes was now posted on the SFC website.

2. History (1992 to present) of SFC officers, meeting places, etc.:

Chair Kuhajda noted that Gerry Dinkins was near completion in his efforts to compile a list of historical information on SFC that would be posted on the website. Hank Bart said he had archived data with historical SFC information and volunteered to send this to Gerry to help complete this task.

3. Presence of SFC Executive Committee at recent AFS meeting in Nashville, TN (2009):

Chair Kuhajda told the membership that SFC had set up a booth at the 2009 American Fisheries Society meeting held in Nashville, TN. This was done in an attempt to share information about SFC and attract new members. Ten new members joined SFC during this time. Additionally, SFC t-shirts were sold. Funds were used to alleviate the cost of the booth at AFS.

4. USFWS 5-year Status Reviews:

Chair Kuhajda announced that the USFWS was undertaking their five-year status reviews which included several fish species of interest to the society. He encouraged the membership to review the species on the list and encouraged SFC member participation in this process.

5. SARP and SFC:

Will Duncan requested further discussion of our potential partnership with SARP. Mel Warren asked Will to give his opinion on what he thinks SFC's influence would be on SARP's steering committee. Will noted that this was a good question, but his impression was that they were very interested in having SFC's input and thus our potential to influence decisions may be

very good. Brett Albanese asked what SFC's actual commitment would be. Chair Kuhajda said that the idea was to have SFC members serve on SARP committees and attend their meetings. He also suggested that we encourage SARP to attend annual SFC meetings to get expert advice on species conservation and recovery plan actions.

Steve Walsh suggested that SFC's Technical Advisory Committee serve as advisor to SARP. It was noted however, that there was currently no one serving on this committee and it would have to be re-activated, but would be a good way to interact with SARP. Walsh stated that the committee could act as an imperiled species work group.

Will Duncan asked what SARP could do to formalize the proposed partnership with SFC. Hank Bart suggested that the SFC executive committee draft a memorandum of understanding that would be sent out to the membership for a vote.

6. Petition to list aquatic species by Center for Biodiversity

Chair Kuhajda explained to the members that the Center for Biodiversity (CBD) had plans to petition USFWS to list 88 southeastern fish species and that Noah Greenwald (CBD) had requested SFC's input on the matter. Chair Kuhajda expressed his concern that many of the species on their petition list were not under immediate threat of extinction and should not be included. He felt that including all 88 species would be a waste of USFWS resources and distract from their efforts of listing those that truly warranted immediate protection. He asked the membership to review the list of species which CBD intended to include on the petition and provide expert feedback as to those that should be removed and those that should be included.

Anna George asked that we clarify and discuss what SFC's role in species petitions should be. Mel Warren noted that none of us had seen the list, which Chair Kuhajda confirmed, and thus this topic was impossible to really discuss. Mel suggested re-activating the Technical Advisory Committee, have this committee get a copy of the list and share with the SFC membership and request feedback and eventually have the membership vote on the list.

Jim Williams asked if SFC's role would be to simply support/not support the petition or actually become a co-petitioner. Chair Kuhajda, Warren, and Bart all expressed the opinion that SFC only support/not support the list and not actually sign the petition. Bart and Williams elaborated expressing the opinion that SFC should avoid taking an active role in signing petitions and focus on serving as facilitators to help conserve

southeastern fishes. They further cautioned that otherwise, SFC may undermine its credibility with USFWS. Andy Sheldon noted that there were many other non-fish species on the list and if SFC signed the petition, we would also be endorsing the listing of other groups for which we are not experts. Peggy Shute noted that many SFC members were USFWS employees and signing the petition could be a conflict of interest for the society. Mark Cantrell stated that there were better ways for SFC to interact with USFWS to raise awareness of the conservation status of southeastern fishes. He cited SFC's generation of the 'Desperate Dozen' list as an example. Jim Williams argued that SFC should take on the role of vetting the list and using our expertise to make suggestions to remove species that should not be on the list to prevent USFWS from getting a list with all 88 species included. Several members expressed their agreement with this approach and Chair Kuhajda stated that he would re-activate the Technical Advisory Committee and ask them to examine the list and provide feedback to the membership.

7. **Petition to List *Elassoma alabamiae***

Members in attendance were presented with information on the status of a proposed development in a five mile stretch of the range of *E. alabamiae* in Beaverdam Creek. Members were asked to consider signing a letter to support listing of the species by USFWS. In this stretch there are plans for a housing development that would greatly impact a substantial portion of the range of the species. The species was previously petitioned for listing which caused considerable issues and concerns with landowners in the area. Chair Kuhajda noted that FWS was reluctant to list the species because they were concerned that this would scare

landowners into no longer cooperating with them in conservation efforts or ultimately in landowners selling properties and allowing development to move forward. Mike Sandel expressed his opinion that the species required emergency listing. Brett Albanese asked if 'petitioning' was the same as 'emergency listing'. Paul Hartfield stated that the decision for an emergency listing of a species was not something that could be requested, but that this action was a decision that could only be made by USFWS. One member noted that FWS was in precarious negotiations with one landowner and that if they were petitioned to list the species, they may lose his support and cooperation. Paul Hartfield noted that based on discussions with the landowner, it seemed that he was willing to consider entering his property into a conservation easement, but at the time there was no concrete or tangible agreement in place. Jim Williams expressed his concern that the landowner may be 'buying time' so that he can sell the property to the interested developers in the region before any conservation measure would prevent development and thus his ability to sell the land. Hartfield also noted that an easement alone may not be enough to ensure proper habitat conservation measures are followed. David Etnier stated that in his view this was a simple case: members of SFC realize that *E. alabamiae* warrants recognition as a federally endangered species and under the mission of our society, we have a strong commitment to do what we can to see that it is listed as quickly as possible.

The meeting was adjourned by Chair Kuhajda at 6:10 p.m.

Respectfully submitted, Secretary Rebecca Blanton Johansen

**2009 Treasurer's Report
for the Southeastern Fishes Council
Prepared by Anna George**

Starting Balance	\$17,386.53
1 January 2009	
EXPENSES	
2009 Annual Meeting	
Lake Guntersville rooms and food	\$4666.95
Student Awards	\$ 600.00
Supplies	\$ 568.28
Coffee mugs	\$ 548.72
Labor	\$ 291.08
Paypal Fees	\$ 287.66
AFS Meeting	
Booth	\$ 500.00
Printing	\$ 41.30
Proceedings Printing	\$2628.00
Proceedings Mailing	\$ 599.50
Miscellaneous Fees	\$ 40.00
Propagation Publication	\$ 612.14
TOTAL EXPENSES	\$11,383.63
INCOME	
Memberships	
15 regular at \$20	\$ 300.00
96 regular at \$30	\$2880.00
2 student at \$10	\$ 20.00
44 student at \$15	\$ 660.00
5 family at \$40	\$ 200.00
2009 Meeting Registration	\$9945.00
2009 Miscellaneous Sales (mugs, buttons, t-shirts, past memberships)	\$1071.00
Grants	
2009 World Wildlife Fund	\$1850.00
Additional Contributions	\$ 280.00
TOTAL INCOME	\$17,206.00
ENDING BALANCE	\$23,208.90
31 December 2009	

Southeastern Fishes Council Proceedings

INFORMATION FOR CONTRIBUTORS

The primary purpose of the *Proceedings* is to publish peer-reviewed research papers and critical reviews of activities; regional reports and notes; and other pertinent information pertaining to the biology and conservation of southeastern fishes. The *Proceedings* is also an outlet for range extensions, distributions, and status papers, covering ecology and conservation ichthyology. Life history studies, faunal surveys, management issues, behavior, genetics and taxonomy of southeastern fishes are appropriate topics for papers in the *Proceedings*. Review papers or information on imperiled waters or fishes are particularly appropriate.

Manuscripts can be submitted electronically via email (send to: dave.neely@gmail.com) or mailed as hard copies to the address below. Mailed hard copies should be submitted in triplicate. A good guide for manuscript preparation is the Sixth Edition of the *CBE Style Manual* available from the Council of Biology Editors, One Illinois Center, Suite 200, 111 East Wacker Drive, Chicago, IL 60601-4298.

The entire manuscript including the Abstract (required for longer articles), Introduction, Methods, Results, Discussion, Acknowledgments, Literature Cited, Appendices, Tables, and Figure Legends must be double-spaced. The title, author's name and author's address (including fax number and email address for corresponding author) should be centered on the first page. Indicate a suggested running head of less than ten words at the bottom of the first page. An Abstract (if necessary) will be placed at the beginning of the text. Acknowledgments will be cited in the text immediately before the Literature Cited. All references cited in the paper will follow the standard format of using the last name of the author(s) followed by the year of publication of the paper. In the Literature Cited, the references will be alphabetical by the author's last name and chronological under a single authorship. Literature cited should be standardized and abbreviated, using the *World List of Aquatic Sciences And Fisheries Serial Titles* or guidelines in *CBE Manual for Authors, Editors, and Publishers, 6th edition* for journals not included in the World List.

Tables should be typed on a separate page, consecutively numbered and should have a short descriptive heading. Figures (to include maps, graphs, charts, drawings and photographs) should be consecutively numbered and if grouped as one figure each part block lettered in the lower left corner. Computer-generated graphics should be high quality prints; for drawings, high quality prints or photocopies are preferred to the original line art. Legends for figures must be on a separate sheet and each figure must be identified on the back. The desired location of each table or figure should be indicated in the margin of the manuscript. When possible, tables and figures will be reduced to one column width (3.5 in), so lettering on figures should be of appropriate size. Color figures can be printed at the author's expense.

Manuscripts will be subject to editing and will be reviewed by at least two anonymous persons knowledgeable in the subject matter. The edited manuscript and page proofs will be furnished to the author. Upon returning the reviewed and corrected manuscript to the editor, a PC disk copy of the final form of the text, tables and computer-generated graphics is also requested. Specific formatting information for the disk will be sent to the author with the edited manuscript. Reprints can be ordered at the time of printing, and will be supplied to the author at the cost of printing.

Regional reports, news notes and other short communications will also be edited and included when possible in the next number.

Only manuscripts from members of The Southeastern Fishes Council will be considered for publication. There is no charge for publishing in the *Proceedings*. All manuscripts and short communications should be sent to the editor:

Dave Neely, Editor
Southeastern Fishes Council Proceedings
Tennessee Aquarium Conservation Institute
5385 Red Clay Road, Cohutta, GA 30710
Phone: 706-694-3957
Email: dave.neely@gmail.com
Southeastern Fishes Council Web Site:
<http://www.sefishescouncil.org>

Proceedings is a publication of the Southeastern Fishes Council, Inc., and is published in Milledgeville, Georgia. Officers are Gerry R. Dinkins, Chair; Carol Johnston, Chair-Elect; Bernard Kuhajda, Immediate Past Chair; Rebecca Blanton, Secretary; and Anna George, Treasurer; Jake Schaefer, Webmaster. Managing Editor for the *Proceedings* is David Neely, Tennessee Aquarium Research Institute, 5385 Red Clay Road, Cohutta, GA 30710, phone 706-694-3957, dave.neely@gmail.com; Associate Editor is Christopher E. Skelton, Department of Biological and Environmental Sciences, Georgia College & State University, Milledgeville, GA 31061, (478)-445-2440, chris.skelton@gcsu.edu. *Proceedings* is printed on recycled paper.

