



University of Tennessee, Knoxville  
**Trace: Tennessee Research and Creative Exchange**

Bulletins

AgResearch

11-1983

# Phenotype x Nutritional Environment Interactions in Economic Efficiency of Angus Cows Grazing Fescue-Legume or Fescue Pastures

University of Tennessee Agricultural Experiment Station

J. W. Holloway

W. T. Butts Jr.

D. L. McLemore

Follow this and additional works at: [http://trace.tennessee.edu/utk\\_agbulletin](http://trace.tennessee.edu/utk_agbulletin)

 Part of the [Agriculture Commons](#)

## Recommended Citation

University of Tennessee Agricultural Experiment Station; Holloway, J. W.; Butts, W. T. Jr.; and McLemore, D. L., "Phenotype x Nutritional Environment Interactions in Economic Efficiency of Angus Cows Grazing Fescue-Legume or Fescue Pastures" (1983). *Bulletins*.

[http://trace.tennessee.edu/utk\\_agbulletin/424](http://trace.tennessee.edu/utk_agbulletin/424)

The publications in this collection represent the historical publishing record of the UT Agricultural Experiment Station and do not necessarily reflect current scientific knowledge or recommendations. Current information about UT Ag Research can be found at the [UT Ag Research website](#).

This Bulletin is brought to you for free and open access by the AgResearch at Trace: Tennessee Research and Creative Exchange. It has been accepted for inclusion in Bulletins by an authorized administrator of Trace: Tennessee Research and Creative Exchange. For more information, please contact [trace@utk.edu](mailto:trace@utk.edu).

Bulletin 626  
November 1983

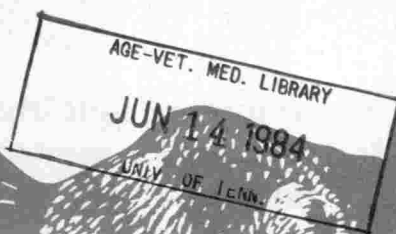

STACKS

Phenotype x Nutritional  
Environment Interactions in  
**Economic Efficiency of  
Angus Cows**  
Grazing Fescue-Legume or  
Fescue Pastures

J. W. Holloway, W. T. Butts, Jr.,  
D. L. McLemore

The University of Tennessee  
Agricultural Experiment Station  
Knoxville, Tennessee  
D. M. Gossett, Dean

# **Phenotype x Nutritional Environment Interactions in Economic Efficiency of Angus Cows Grazing Fescue-Legume or Fescue Pastures**

J. W. Holloway<sup>1</sup>, W. T. Butts, Jr.<sup>2</sup> and D. L. McLemore<sup>3</sup>

## **SUMMARY**

The purpose of this research was to determine the relationship between cow phenotype (frame size, fatness and milk production) and economic efficiency of Angus cows and calves grazing fescue-legume or fescue pastures. Data were collected on 146 lactations of 87 mature Angus cows varying widely in frame size, fatness and milk production, grazing fescue-legume or fescue pastures over a 4-year period. These data included forage production and intake, cow and calf weight, cow height and fatness at weaning and milk production. From these variables, cow frame size, cow fatness, land requirements and costs and revenue were calculated for each cow-calf pair.

The hypothetical production unit used for comparison was a 100-acre pasture unit stocked with 50 average type Angus cows (2 acres/cow). The two pasture systems were fescue-legume (red and white clover and lespedeza renovated every 4 years) and fescue. All cows were assumed to be mature (5-10 years of age) with a 20% turnover rate each year. Five-year-old stock cows were purchased at auction to replace 10-year-old cows sold for slaughter. Since replacement cows were assumed to be purchased, all weaning calves were sold at auction. Since all cows were mature, attrition was due to a 2% death loss and culling on the basis of age rather than reproductive rate. Ninety-five percent of the cows were assumed to wean calves (5% calf death loss) on both pasture types.

For fescue-legume pasture systems, the type of cow providing the largest net returns to land was characterized as thin and giving large amounts of milk. Frame size was not an important factor affecting net returns for this system. For the fescue pasture system, a small frame cow giving large amounts of milk resulted in the greatest net returns to land. Cow fatness was not an important variable for the fescue pasture system. Thus, the type of cow desirable for maximum economic efficiency was not the same for the two types of pasture. It is erroneous to believe that one type of cow has the greatest economic advantage regardless of pasture management. To the contrary, each type of cow possibly has a niche in a particular component of the array of pasture management systems presently available in the U. S.

---

<sup>1</sup> Animal Science Dept.

<sup>2</sup> USDA-ARS, Animal Science Dept.

<sup>3</sup> Agricultural Economics and Rural Sociology Dept.

## INTRODUCTION

Ideal beef cow type is a controversial topic among beef producers. The controversy centers around two problems: (1) there are no universally accepted criteria for measuring the "best" types and (2) the relationship of visually perceptible traits to production traits of economic importance is not clear. This lack of clarity is the result of each producer making observations on his own farm and then comparing observations with other producers who have made observations that are divergent. It is possible that each producer's observations are correct and that, in reality, the divergence results from different natural phenomena controlling the economically important relationships on each farm (microenvironment). Each microenvironment is largely defined by type of pasture provided for the cattle. Thus, the variation in opinion concerning ideal type is possibly the result of genotype x environment interactions. Some research substantiating this hypothesis has been reported (Butts *et al.*, 1971; Burns *et al.*, 1979; Koger *et al.*, 1979; Holloway and Butts, 1983).

From the producer's point of view, the ultimate criterion for evaluating the "idealness" of cow type for a particular environment must be economic efficiency in terms of net returns. The purpose of this experiment was to determine the economic merit of an array of cow types allowed either fescue or fescue-legume pastures. The primary purpose, therefore, was to study the interaction of animal phenotype (described by frame size and fatness) with nutritional environment (fescue vs fescue-legume) and the resulting effects on the economics of production. All economic data were calculated on a cow-calf pair basis and were based on individual animal measurements, application of accepted prices and prices developed from independent data sets. It was not the primary purpose of the experiment to compare fescue and fescue-legume pastures although some discussion of this was necessary as background for evaluation of phenotype x nutritional environment interactions.

## MATERIALS AND METHODS

**Animal Management.** Data from 146 lactations of 87 mature Angus cows were obtained over a period of 4 years (1977-1980). Cows calved January through March and calves were weaned in October each year. Cows entering the experiment were randomly allotted to either fescue-legume or fescue pastures at calving time each year. An attempt was made to equalize soil productive capacity for the two pasture types. Fescue-legume pastures consisted of about 60 to 70% Kentucky-31 tall fescue (*Festuca arundinacea* Shreb.) and 30 to 40% legume consisting of red clover (*Trifolium pratense* L.), Korean and Kobe lespedeza (*Lespedeza stipulacea* Maxim. and *L. striata*, respectively) and white clover (*Trifolium repens* L.). Fescue pastures were almost homogeneous stands of tall fescue. Within

pasture type, cows and calves were allotted to two 20-acre pastures (10 cows and calves per pasture). Cows were rotated among pastures within a pasture type each week. Cows were allowed hay cut from the pastures from January to March. Hay was harvested from the pastures in June. The herbicide, Banvel® , was applied to the fescue pastures in May to assure homogeneous fescue stands. Male calves were castrated in April. Detailed descriptions of allotment and animal management procedures have been reported by Holloway *et al.* (1979) and Brown *et al.* (1980).

**Animal Measurement.** Forage intake of the cows was estimated continuously from April 29 to September 28 (152 days) by the internal ( $H_2SO_4$  acid detergent lignin, ADL), external ( $Cr_2O_3$ ) indicator technique described by Holloway *et al.* (1979). Average forage intake during the grazing (lactation) season was then computed from daily estimates. Three forage intake trials were conducted on the calves each year by the internal (ADL), external ( $Cr_2O_3$ ) indicator technique described by Holloway *et al.* (1982). Average forage intake of the calf and the cow during the grazing season was summed and this value was employed to calculate land requirements for each cow.

Cow hook width, wither height, length from point of shoulder to pin and depth at heart girth were measured during the fall prior to the year of intensive measurement by the method of Brown *et al.* (1980). Cow weight and fat cover over 12th rib (ultrasonic measurement) were also measured at this time and again at monthly intervals during lactation. These measurements were regressed on time (Brown *et al.*, 1980) and the resulting equations evaluated for weaning time to determine weight and fat cover for estimation of salvage cow price. The initial cow weight and fat cover (before allotment) was utilized to compute replacement cow price. A factor analysis was performed on the initial measurements (weight, fat cover, height at withers, length from point of shoulder to pin, hook width and depth at heart girth) to provide a simplified description of the physical characteristics of the cows. This analysis resulted in two orthogonal factors that explained 70% of the communal correlation structure. Factor 1, explaining 49%, reflected structural dimension of the cows whereas factor 2, explaining an additional 21% of the correlation structure, reflected fat cover. Cows with large values for factor 1 had large frames being relatively taller and longer whereas cows with larger values for factor 2 had large amounts fat cover (Holloway and Butts, 1983).

Twenty-four-hour milk productions were measured at monthly intervals beginning in March or April of each year and continuing until October. Milk production was regressed on time to describe these lactations and average milk production (during lactation) was calculated from these equations (Holloway *et al.*, 1979).

Calves were weighed at weaning (about 240 days of age). Fat cover (ultrasonic measurement) and wither height measurements on the calves were also taken at that time.

**Economic Analysis.** Since the physical experiment utilized a stocking rate of 2 acres/cow-calf for both types of pasture, this average stocking rate was used for the economic analysis. Excess forage was sold for hay and therefore hay sales reflect, to a large extent, differences in forage production between pasture types. Land requirement for each cow was determined by first calculating relative forage intake. This was obtained by dividing the forage intake of each cow and calf during lactation by the average forage intake of all cows and calves during lactation grazing that pasture type. This provided a value for forage intake relative to the intake of an average cow grazing each pasture type. The number of pairs that could be grazed on 100 acres if all the pairs had similar forage intakes of a particular cow-calf pair was then calculated. This was accomplished by dividing the average number of cows/100 acres (50) by the relative forage intake of each cow-calf pair. This gave a value for each cow-calf pair in terms of the number of pairs of like intake that could graze 100 acres of land. This value will be referred to as cows/100 acres.

Feeder calf prices were calculated for each calf from the actual weaning data collected (weight, fat cover and wither height) through equations developed from an independent data set. This data set consisted of prices paid for 1,249 feeder calves of Angus, Hereford, Angus-Hereford crosses and Charolais crosses purchased by the Tennessee Agricultural Experiment Station from 1975 to 1981. Weight, fat cover and wither height of these calves were measured at time of purchase and these measurements encompassed the range detected in the calves under study. Regression procedures were used to predict price utilizing the following model:

- (1) Calf price, \$/100 lb = October cash corn price, June slaughter cattle futures price, breed, height (in), fat (mm), weight (lb), 2-way interactions.

The hypothesis implied in this model was that price is associated with measurable traits of feeder calves and with indicators of the profitability of feeding. Average cash corn prices for October were obtained from *Tennessee Agricultural Statistics* (1975-1981), whereas, June slaughter cattle futures prices were obtained from the *Chicago Mercantile Exchange Yearbook* (1975-1981). Corn and slaughter cattle futures prices were included because these are the two basic pieces of information available to feedlot operators at the time of feeder cattle purchase and are indicators of the likelihood of profitability in feeding cattle (or corralarily the value of feeder cattle). The intercept was adjusted to a 1980 basis by inserting the 1980 October average cash corn price and the October 1980 average price for the June slaughter cattle futures contract. The intercept was also adjusted to the Angus breed. The non-significant ( $P < .05$ ) terms were eliminated and the resulting model reestimated. The resulting model was:

- (2) Calf price, \$/100 lb =  $302.7581 - (186.22 \times \$2.65/\text{bushel of corn}) + (3.8649 \times \$57.11/100 \text{ lb June slaughter cattle futures price}) + (.1765 \times 2.65/\text{bushel of corn} \times 57.11/100 \text{ lb June slaughter cattle futures price})$

price) + (1.5117 x height) + (.5948 x fat) - (.0267 x 57.11 x height). This equation accounted for 92.9% of the variation in calf prices with a residual standard deviation of \$5.52/100 lb. Weanling calf returns (\$/100 acres) were calculated as follows:

$$(3) \text{ Weanling calf returns, } \$/100 \text{ acres} = \text{calf price, } \$/\text{lb} \times (\text{weanling weight, lb} \times .97) \times \text{cows}/100 \text{ acres} \times .95.$$

Underlying assumptions were that calf marketing shrink was 3% and that 95% of the cows wintered weaned a calf. A 5% calf attrition rate at calving was observed in this study involving mature cows.

Salvage cow price was defined as the price received for cull cows sold for slaughter and was calculated for each cow from cow weight and fat cover data. Guidelines used by the USDA Meat Grading Service were utilized to classify the cows into the four grades (Gary Stooksberry, 1982, personal communication). These guidelines were: commercial had greater than .8 in fat cover between the 12th and 13th ribs, 5 cm from midline; utility had greater than .25 and less than .8 in; cutter had greater than .1 and less than .25 in and canner had less than .1 in. Data concerning the average price paid for the four grades were obtained from the USDA, Agricultural Marketing Service, *Livestock, Meat, Wool Market News* over the 1971-1980 period. The difference in prices between grades were then applied to the overall 1980 average price. Over the 1971-1980 period, the average difference between commercial and utility was \$.15/100 lb; between utility and cutter was \$1.81/100 lb; and between cutter and canner was \$1.98/100 lb. Salvage cow returns (\$/100 acres) were then calculated as follows:

$$(4) \text{ Salvage cow returns, } \$/100 \text{ acres} = (\text{salvage cow price, } \$/\text{lb}) \times (\text{cow wt at weaning, lb} \times .97) \times (.2 \times \text{cows}/100 \text{ acres}).$$

The implied assumptions were that marketing shrink was 3% and that 20% of the herd was culled (attained 10 years of age) each year. The herd was assumed to consist of only mature cows (5-10 years of age), and those attaining 10 years of age were sold and replaced with younger cows (5-year-olds). The data set involved in this analysis consisted of 5-10 year old cows. A regression of cow weight and fat cover at weaning on cow age indicated no relationship ( $P > .10$ ) so that each cow's weight and fatness was used to calculate her salvage value regardless of her age.

Returns from hay production in excess of animal requirements were calculated from forage production values obtained in this study and from a study conducted by Fribourg (1978). Hay price (\$60/ton) was obtained from values in Ray and Walch (1981).

Pasture costs were calculated using 1980 prices as shown in table 1 (Ray and Walch, 1981). The primary differences in pasture costs for the two pasture types were increased seed cost in pasture establishment (9 lb ladino and 6 lb red clover per acre), increased overseeding cost (9 lb lespedeza and 6 lb red clover overseeded every 4 years) and decreased N cost (a decrease of 15 lb N/year) of the fescue-legume pasture as compared to the fescue pasture. Table 2 summarizes the cow-calf operation cost (Ray and Walch,

1981). These values were the same for both pasture types except for interest on cows and bull, depreciation on fences and death loss. These values were omitted from table 2 because calculation depended on type of cow and cows/100 acres. The methods of calculation for these expenses were as follows:

- (5) Interest on cows and bull, \$/100 acres =  $\{(1 \text{ bull}/30 \text{ cows} \times 1000/\text{bull}) + (\text{replacement price, } \$/\text{cow})\} \times (.105 \text{ annual interest rate}) \times \text{cows}/100 \text{ acres}.$
- (6) Depreciation on fences = \$2.45/acre (Ray and Walch, 1981).
- (7) Death loss, \$/100 acres =  $.05 \times \{(\text{salvage cow returns, } \$/100 \text{ acres}) + (1 \text{ bull}/30 \text{ cows} \times \$1000/\text{bull} \times \text{cows}/100 \text{ acres})\}.$

The other expense was replacement cost. Replacement cost was defined as the cost of buying young stocker cows of a type similar to the cull cows eliminated from the herd. Replacement cost was calculated from actual data (frame size and thickness) through the use of a regression equation relating market price of stock cows to these variables. The only markets reporting adequate information for the development of this equation were central and east Texas auctions as reported in the *Texas Livestock Market News* (Texas Department of Agriculture). This data source was thought to adequately distinguish among cattle types although the pricing was from a different geographical area from that used for other prices. Fifty-four weekly average prices were attained over the 1980-1982 period for the calculation of the relationship of replacement price to frame size and thickness. The initial model employed was:

- (8) Replacement cow price, \$/100 lb = date (Julian day with day 1 = Jan. 1, 1980), frame size, thickness, age, weight, 2-way interactions.

Date was included in the model to account for the changes in price associated with the cattle cycle. Other independent variables in the model were reported by the *Texas Livestock Market News* and attainable from data collected in this study. Frame size in *Texas Livestock Market News* data was designated as large = 1, medium = 2, and small = 3. Thickness was designated as thick = 1 and moderately thick = 2.

Frame size for the cows in this study was calculated from cow weight and fatness data. The Missouri frame scoring method was used to bracket the cows in this study into the frame size classifications reported by the *Texas Livestock Market News*. Small frame cows were those that produced calves that weighed less than 925 lb at .5 in fat cover (Mo frame sizes 1, 2). Large frame cows were those producing calves that weighed more than 1125 lb at .5 in fat cover (Mo frame sizes 5, 6 and 7). Other cows had a medium frame (Mo frame sizes 3, 4). Cow weight adjusted to a constant (the average) fat cover was assumed to be equivalent to the weight of their calves at .5 in fat cover. In order to adjust weight for degree of fat cover, the relationship of cow weight to fat cover was estimated for these data by regression procedures:



(9) Cow weight, lb =  $973.09 + 10.5160 \times \text{mm fatness}$  ( $R^2 = .24$ ,  $RSD = 97.69$  lb).

This relationship was shown not to be curvilinear over the span of these data (quadratic terms were tested, found not to be significant and omitted in subsequent models). Each cow's weight was then adjusted to a constant fat cover:

(10) Cow weight at constant fat cover, lb = cow weight during fall, lb +  $\{(6.82 \text{ mm average cow fat cover} - \text{fat cover of particular cow}) \times 10.5160 \text{ lb/mm fat cover.}\}$

The resulting weights were bracketed into large, medium and small frame sizes. Thickness as reported by the *Texas Livestock Market News* (#1 and #2) was determined by arbitrarily defining #1 as those cows having more than 4 mm of fat cover at the initiation of the trial and #2 as having less than 4 mm.

Nonsignificant terms ( $P > .10$ ) were omitted and the initial model (equation 8) adjusted to 1980 prices. The resulting simplified model was:

(11) Replacement price, \$/100 lb =  $119.8757 - (15.6472 \times \text{frame size}) - (19.4728 \times \text{thickness}) - (.7348 \times 5 \text{ years of age}) - (.0384 \times \text{cow weight at initiation of trial} \times .97) + (6.1117 \times \text{frame size} \times \text{thickness})$ . ( $R^2 = .68$ , Residual Standard Deviation = \$2.25/100 lb.)

Cow frame size, thickness and weight were entered into equation 11 to obtain replacement price. Replacement cost, \$/100 acres was then calculated:

(12) Replacement cost, \$/100 acres = replacement price, \$/lb  $\times$  cow weight at initiation of trial  $\times .97$   $\times$  cows/100 acres  $\times .2$ .

The assumptions were that marketing shrink was 3% and that 20% of the cows were replaced each year.

Cost of hay harvest (\$/100 acres) was calculated by multiplying hay yield estimates in tons/100 acres by \$36.10/ton (Ray and Walch, 1981).

**Statistical Analysis.** Cost and return variables of interest were used as dependent variables designed to detect the influence of cow type on economic efficiency. The model employed was:

(13)  $\hat{Y}$  = year, calf sex, calf birth date, factor, factor<sup>2</sup>, milk production, milk production<sup>2</sup>, interactions involving milk production and factor.

Where  $\hat{Y}$  = data sets of economic variables calculated for each pair and factor = either factor 1 or factor 2. Nonsignificant variables were then deleted and the model was refitted. For these analyses, cow-calf pair was the experimental unit.

## RESULTS AND DISCUSSION

**Influence of Frame Size and Milk Production.** Frame size (factor 1) was generally not related ( $P > .10$ ) to either costs or returns to cow-calf production for fescue-legume pasture but was highly related ( $P < .01$ ) for fescue pasture (table 3). For fescue-legume, as frame size increased, stocking rate (cows/100 acres) decreased and this was offset by increased salvage

cow returns/100 acres. Frame size was not related to other costs and returns. Therefore, variation in frame size did not impact net returns to land (\$/100 acres) for fescue-legume pasture.

Cows grazing fescue-legume giving more milk had lower replacement costs and salvage cow returns (\$/100 acres, partial b's in table 3) resulting from decreased number of cows maintained per 100 acres. This was offset, however, by a large positive response in terms of weanling calf returns. The increased weanling calf returns associated with increased milk production were results of increased weanling calf price (increased height and weight) and increased weaning weight. These effects more than offset the negative effect of reduced number of calves (reduced number of cows/100 acres) sold (table 3). As a result, net returns to land increased at the rate of \$483/100 acres per lb increase in daily milk production for cows grazing fescue-legume pastures.

The influence of frame and milk production on costs and returns of cows grazing fescue pastures was much more complex than for those grazing fescue-legume (table 3). As frame size increased, there was a curvilinear decrease in cows/100 acres (figure 1 and table 3). This decrease was partially compensated by a trend toward increased replacement cost (\$/100 lb, figure 2). These partially offsetting factors resulted in a generally negative influence of frame size on replacement cost calculated as \$/100 acres (table 3).

Although frame size was negatively related with stocking rate and salvage cow price (\$/100 lb) for cows grazing fescue pasture, the positive relationship with cow weight resulted in a positive relationship with salvage cow returns/100 acres (figure 3, table 3). Also, because of the generally negative relationships between cow frame size and weanling calf price (\$/cwt) and stocking rate, frame size (factor 1) was also negatively related to weanling calf returns (\$/100 acres, table 3). Apparently, the primary cause for this was the reduced number of cows that low quality fescue pasture could support as frame size increased.

Because the trend in relationship between frame size and replacement cost was in the opposite direction and offset the trend between frame size and salvage cow returns, the relationship between frame size and net returns to land was largely a reflection of the relationship between frame size and weanling calf returns (figure 4, table 3).

For cows grazing fescue, a 1.42 decrease in cows/100 acres could be maintained per pound increase in average daily milk production (figure 1, table 3). Replacement cost (\$/100 acres), however, was positively related to milk production as was total cost (table 3). On the returns side, salvage cow returns (\$/100 acres) were not related to milk production and therefore trends in animal returns and net returns to land (\$/100 acres) reflected the positive relationship of milk production to weanling calf returns (\$/100 acres, table 3). Milk production had a much stronger impact on calf weaning weight, weanling calf returns and net returns to land and management for

fescue than for fescue-legume pasture. For fescue pasture a \$701/100 acres increase in net returns to land resulted from each lb increase in daily milk production ( $R^2 = .218$ , table 3) whereas for fescue-legume a \$483/100 acres increase in net returns to land and management was associated with each pound increase in milk production ( $R^2 = .100$ ). Holloway *et al.* (1982) showed that milk production was more important for calf growth as pasture quality deteriorates.

Apparently, the observable characteristics of frame size and milk production were of much more importance in terms of economic efficiency for production systems involving fescue than for those involving fescue-legume. The most efficient cow grazing fescue was small of frame but gave large amounts of milk. The most efficient cow grazing fescue-legume was a high milking cow regardless of frame size.

**Influence of Cow Fatness and Milk Production.** Cow fat cover (factor 2) tended to have more effect on costs and returns for fescue-legume than for fescue pastures (table 4). For fescue-legume, as cow fat cover increased the primary economic effects were (1) an increase in salvage cow returns (\$/100 acres, figure 5), (2) an increase in replacement costs \$/100 acres, table 4), and (3) a decrease in weanling calf returns (\$/100 acres, figure 6). The decrease in weanling calf returns had a great impact on and is reflected in an associated decrease in animal returns as cow fat cover increased (figures 6 and 7). Total cost of production was not related to cow fat cover so that the relationship between cow fat cover and net returns to land was similar to the relationship of cow fat cover and weanling calf returns (figure 7, table 4). For fescue-legume pasture, fatter cows apparently tended to wean lighter, thinner calves that were of lower value and this had a negative influence on net returns to land and management.

For fescue-legume pastures, the influence of cow fat cover on costs and returns was not the same for all levels of milk production. The impact of cow fat cover on these variables was much greater at 4 lb milk/day than at 7 lb/day (figures 6 and 7). Thus, for fescue-legume systems involving low-milking cows, thin cows resulted in relatively high net returns to land. For similar systems involving heavy milking animals, cows varying in fat cover had about the same net returns to land and management (figure 7).

Relationships between cow fat cover and costs and returns were linear for fescue whereas these relationships tended to be curvilinear for fescue-legume. For cows grazing fescue, cow fat cover had a greater impact on replacement cost and salvage cow returns (\$/100 acres) but a much lower impact on weanling calf returns (\$/100 acres, table 4). Thus, in contrast to the fescue-legume pasture system, the trade-off between increased salvage returns and increased replacement costs that accompanied increased fat cover was the primary factor defining the relationship of cow fat cover and net returns to land and management (\$/100 acres). These two factors effectively counter-balanced each other so that cow fat cover was not related ( $P > .10$ ) to net returns to land for fescue pasture systems (figure 8).

## LITERATURE CITED

- Brown, W. F., J. W. Holloway and W. T. Butts, Jr. 1980. Patterns of change in mature Angus cow weight and fatness during the year. *J. Anim. Sci.* 51:43.
- Burns, W. C., M. Koger, W. T. Butts, O. F. Pahnish and R. L. Blackwell. 1979. Genotype by environment interaction in Hereford cattle: II. Birth and weaning traits. *J. Anim. Sci.* 49:403.
- Butts, W. T., M. Koger, O. F. Pahnish, W. C. Burns and E. J. Warwick. 1971. Performance of two lines of Hereford cattle in two environments. *J. Anim. Sci.* 33:923.
- Chicago Mercantile Exchange Yearbook.* 1975-1981.
- Fribourg, H. A. 1978. Tall fescue productivity after renovation with legumes and fertilization with nitrogen. *Tennessee Farm and Home Science Progress Report* 107.
- Holloway, J. W. and W. T. Butts, Jr. 1983. Phenotype x nutritional environment interactions in forage intake and efficiency of Angus cows grazing fescue-legume or fescue pastures. *J. Anim. Sci.* 56: 960.
- Holloway, J. W., W. T. Butts, Jr., J. D. Beaty, J. T. Hopper and N. S. Hall. 1979. Forage intake and performance of lactating beef cows grazing high or low quality pastures. *J. Anim. Sci.* 48:692.
- Holloway, J. W., W. T. Butts, Jr. and T. L. Worley. 1982. Utilization of forage and milk energy by Angus calves grazing fescue or fescue-legume pastures. *J. Anim. Sci.* 55:1214.
- Koger, M., W. C. Burns, O. F. Pahnish and W. T. Butts. 1979. Genotype by environment interactions in Hereford cattle. I. Reproductive traits. *J. Anim. Sci.* 49:396.
- Livestock, Meat, Wool Market News.* Selected issues from 1971-1980. USDA, Agricultural Marketing Service.
- Ray, R. M. and H. W. Walch. 1981. *Farm Planning Manual: A Guide for Increasing Income.* Tennessee Agricultural Extension Service publication E.C. 622.
- Stooksberry, Gary. 1982. USDA Meat Grader. Personal communication.
- Tennessee Agricultural Statistics.* 1975-1981. Tennessee crop reporting service statistics annual bulletin. Tenn. Dept. of Agriculture.

**Table 1. Pasture Costs/Acre (Excluding Land Cost)<sup>a</sup>**

Item	Description	Unit	Pasture type					
			Fescue-Legume			Fescue		
			Quantity	Price, \$	Amount, \$	Quantity	Price, \$	Amount, \$
Establishment cost								
Seed	Ladino clover	lb	9	.60	5.40			
	Red clover	lb	6	1.52	9.12			
	Fescue	lb	12	.32	3.84	12	.32	3.84
Inoculation	Clover type	pkg	.3	.80	.24			
Fertilizer	N	lb	30	.25	7.50	30	.25	7.50
	P <sub>2</sub> O <sub>5</sub>	lb	90	.27	24.30	90	.27	24.30
	K <sub>2</sub> O	lb	90	.15	13.50	90	.15	13.50
Lime		ton	2	10.00	20.00	2	10.00	20.00
Tractor	Var. & fixed cost	hr	2.05	7.70	15.78	2.05	7.70	15.78
Other machinery					9.83			9.83
Labor					9.00			9.00
Total					118.51			103.75
	(prorated over 10 years)				11.85			10.38
Annual variable								
Cost								
Fertilizer	N	lb	15	.25	3.75	30	.25	7.50
	P <sub>2</sub> O <sub>5</sub>	lb	45	.27	12.15	45	.27	12.15
	K <sub>2</sub> O	lb	45	.15	6.75	45	.15	6.75
Lime		ton	.2	10.00	2.00	.2	10.00	2.00
Tractor	60 PTO-HP	hr	1	5.26	5.26	1	5.26	5.26
Other machinery					1.28			1.28
Other expenses					2.54			2.54
Labor					1.75			1.75
Total					35.48			39.23
Annual fixed cost including establishment cost								
	Prorated establishment cost				11.85			10.38
	Overseeding cost (prorated over 4 years)				4.46			
Seed	Lespedeza	lb	9	.60	5.40			
	Red clover	lb	6	1.52	9.12			
Inoculation	Clover type	pkg	.3	.80	.24			
Tractor					3.08			
Total					17.84		10.38	
Total annual costs per acre					53.32		49.61	

<sup>a</sup>Source: Ray, R. M. and H. N. Walch. 1981. Farm Planning Manual: A Guide for Increasing Income. Agricultural Extension Service Publication E. C. 622, University of Tennessee, Knoxville.

**Table 2. Cow-Calf Operation Cost Excluding Pasture Costs<sup>a</sup>**

<b>Item</b>	<b>Annual cost per cow unit, \$</b>
<b>Variable costs</b>	
Salt and minerals	2.04
Veterinary, medicine	11.60
Marketing	18.60
Trucking	1.50
Tractor	2.26
Interest on cows and bull <sup>b</sup>	f
Bull depreciation	2.83
Total	38.83
<b>Fixed costs</b>	
Depreciation on buildings and equipment	7.30
Repairs on buildings and equipment	2.19
Depreciation on fences <sup>c</sup>	f
Tractor	1.50
Interest on buildings and equipment	7.66
Interest on tractor	.74
Total	19.39
Labor <sup>d</sup>	31.50
Death loss <sup>e</sup>	f

<sup>a</sup>Source: Ray, R. M. and H. W. Walch. 1981. Farm Planning Manual: A Guide for Increasing Income. Agricultural Extension Service Publication E. C. 622, University of Tennessee, Knoxville.

<sup>b</sup>Calculated as  $\{(1 \text{ bull}/30 \text{ cows} \times \$1000 \text{ bull}) + \text{replacement price, } \$/\text{cow}\} \times .105$  annual interest rate.

<sup>c</sup>Calculated as \$2.45/acre.

<sup>d</sup>Calculated as \$3.50/hour for 9 hours.

<sup>e</sup>Death loss = 2% of cow value.

<sup>f</sup>Excluded here because these costs vary with type of cow and number of cows/100 acres.

**Table 3. Influence of Cow Frame Size (Factor 1) and Milk Production on Costs and Returns to Cow-Calf Production from Fescue-Legume and Fescue Pastures<sup>a</sup>**

PASTURE TYPE											
Fescue-legume											
Dependent variable (Y)	Intercept <sup>b</sup>	Factor 1	Factor 1 <sup>2</sup>	Milk prod.	Milk prod. <sup>2</sup>	Factor 1 x milk prod.	Factor 1 <sup>2</sup> x milk prod.	Factor 1 x milk prod. <sup>2</sup>	Factor 1 <sup>2</sup> x milk prod. <sup>2</sup>	R <sup>2</sup> <sup>c</sup>	RSD <sup>d</sup>
Cows per 100 ac	61.63	-1.17		-1.47						8.4	4.88
Costs											
Replacement cost, \$/100 lb		None significant <sup>e</sup>									
Replacement cost, \$/100 ac	4718.			-121.32						4.3	630.00
Total, \$/100 ac	20435.79			-306.87						8.4	1061.12
Returns											
Salvage cow price, \$/100 lb	44.64			-.26						8.0	.81
Cow grade	1.80			+.03	+ .0094						
Cow weight, lb	755.74	+111.56		+115.22	-9.6764					4.7	73.81
Salvage cow returns, \$/100 ac	5602.47	+332.42		-191.84						25.5	463.66
Weaning calf price, \$/100 lb	54.76			+.75	-.0453					4.2	.48
Weaning weight, lb	305.52	-3.29		+30.73						24.9	38.87
Weaning height, in	36.90	-.1818		+.49						22.7	1.60
Weaning fatness, in	.042			+.05	-.0050					4.1	.82
Weaning calf returns, \$/100 ac	11183.31			+318.70						3.5	1440.34
Animal returns, \$/100 ac		None significant									
Net returns to land and management, \$/100 ac	-893.87	+483.07								10.0	1240.81
Fescue											
Dependent variable (Y)	Intercept <sup>b</sup>	Factor 1	Factor 1 <sup>2</sup>	Milk prod.	Milk prod. <sup>2</sup>	Factor 1 x milk prod.	Factor 1 <sup>2</sup> x milk prod.	Factor 1 x milk prod. <sup>2</sup>	Factor 1 <sup>2</sup> x milk prod. <sup>2</sup>	R <sup>2</sup> <sup>c</sup>	RSD <sup>d</sup>
Cows per 100 ac	58.24	-1.38	+.8036	-1.42						9.2	5.03
Costs											
Replacement cost, \$/100 lb	3677.87	+48.78	-731.2960	+9.67	+4.3695		+363.7257		-39.1234	8.8	411.62
Replacement cost, \$/100 ac	2725.72	-1300.30	+165.2515	+639.69	-71.0822	+736.6303		-74.7978		18.3	591.14
Total, \$/100 ac	16848.57	+520.70	+239.0300	+180.55						10.6	992.85
Returns											
Salvage cow price, \$/100 lb	44.62	-2.80		-.13	-.0121	+1.2669		-.1176		8.7	1.04
Cow grade	2.06	+1.56	-.0346	+.04	+.0085	-.7125		+0.667		9.7	.56
Cow weight, lb	1058.37	+103.22								49.2	77.12
Salvage cow returns, \$/100 ac	4869.16	+377.35	+104.9005							21.1	460.15
Weaning calf price, \$/100 lb	54.81	-1.86	-.0413	+.80	-.0619	+6.963		-.0609		26.3	.44
Weaning weight, lb	286.05	-3.21	-6.9663	+32.43						35.7	42.93
Weaning height, in	32.90	+3.5	-.1452	+1.26	-.0617					7.3	1.23
Weaning fatness, in	-.05	-.13	-.0030	+.06	-.0043	+0.489		-.0043		26.6	.76
Weaning calf returns, \$/100 ac	9014.24	-388.27		+589.66						13.9	1430.33
Animal returns, \$/100 ac	14087.28			+454.46						5.5	1598.72
Net returns to land and management, \$/100 ac	3686.00	-279.74	7.86	+701.04						21.8	1349.25

<sup>a</sup>Values are coefficients of partial regression from the model  $Y = \text{year, calf sex, calving date, calf sex} \times \text{calving date, factor 1, factor 1}^2, \text{milk production, milk production}^2, \text{factor 1} \times \text{milk production, factor 1}^2 \times \text{milk production, factor 1}^2 \times \text{milk production}^2$ .

Non-significant ( $P > .10$ ) variables were omitted in final models.

<sup>b</sup>Intercept was adjusted for the average effect of year, calf sex, calving date and calf sex x calving date.

<sup>c</sup>Increased R<sup>2</sup> above variation explained by year, calf sex, calving date and calf sex x calving date.

<sup>d</sup>Residual standard deviation.

<sup>e</sup>No variables other than those in the basic model were significant ( $P < .10$ ).

Table 4. Influence of Cow Fatness and Milk Production on Costs and Returns to Cow-Calf Production from Fescue-Legume and Fescue Pastures<sup>a</sup>

PASTURE TYPE												
Fescue-legume												
Dependent variable	Intercept <sup>b</sup>	Factor 2	Factor 2 <sup>2</sup>	Milk prod.	Milk prod. <sup>2</sup>	Factor 2 x milk prod.	Factor 2 <sup>2</sup> x milk prod.	Factor 2 x milk prod. <sup>2</sup>	Factor 2 <sup>2</sup> x milk prod. <sup>2</sup>	R <sup>2</sup> c	RSD <sup>d</sup>	
Cows per 100 ac	61.80	-1.94		-1.78						14.9	4.75	
<b>Costs</b>												
Replacement cost, \$/100 lb	34.58	+25.26		+1.39	-.1284	-8.5227		+.6714		18.4	357.26	
Replacement cost, \$/100 ac	5016.95	+76.05								1.2	601.49	
Total, \$/100 ac	20435.72			-306.87						8.3	1061.12	
<b>Returns</b>												
Salvage cow price, \$/100 lb	45.79	-.30	-.1763	-.27				-.1453		14.0	.75	
Cow grade	1.47	+.18		-.15		-.0827				8.5	.50	
Cow weight, lb	972.11	+113.82		+16.26						49.6	70.97	
Salvage cow returns, \$/100 ac	5468.81	+295.05	-372.7495	-178.41				-66.4823		17.3	461.55	
Weanling calf price, \$/100 lb	52.87	-.08	+6476	+1.21	-.0740			-.1058		17.1	.46	
Weaning weight, lb	285.88			+33.10						26.8	38.62	
Weaning height, in	34.69			.57						10.7	1.76	
Weaning fatness, in	-.23	-.18	+.0470	+.09	-.0057	+.059	-.0079	-.0044		29.5	.03	
Weanling calf returns, \$/100 ac	11059.68	-2683.26	+246.6114	+292.34		+313.5212				15.1	1307.44	
Animal returns, \$/100 ac	16173.65	-2732.00	+242.5713	+173.42		+382.76				11.3	1545.81	
Net returns to land and management, \$/100 ac	4023.94	-2188.31	+295.1842	+444.62		-266.9690				17.7	1132.65	
Fescue												
Dependent variable	Intercept <sup>b</sup>	Factor 2	Factor 2 <sup>2</sup>	Milk prod.	Milk prod. <sup>2</sup>	Factor 2 x milk prod.	Factor 2 <sup>2</sup> x milk prod.	Factor 2 x milk prod. <sup>2</sup>	Factor 2 <sup>2</sup> x milk prod. <sup>2</sup>	R <sup>2</sup> c	RSD <sup>d</sup>	
Cows per 100 ac	59.84			-1.49						7.2	5.31	
<b>Costs</b>												
Replacement cost, \$/100 lb		None Significant <sup>e</sup>		+90.44						8.9	642.78	
Replacement cost, \$/100 ac	4046.08	+372.63		-284.88						6.7	1016.79	
Total, \$/100 ac	18373.21											
<b>Returns</b>												
Salvage cow price, \$/100 lb	44.50	+.67	-.1517	-.19						30.7	.91	
Cow grade	2.12	-.36	+.0816	+.1003						30.8	.48	
Cow weight, lb	1097.23	+77.31	-333.1099	-36.04				+153.5151	-16.4848	55.4	82.41	
Salvage cow returns, \$/100 ac	4937.12	+317.75		-118.76						19.0	459.44	
Weanling calf price, \$/100 lb	54.96			+.63	-.0419					10.8	.45	
Weaning weight, lb	274.11	-5.05		+33.37						37.9	43.19	
Weaning height, in	34.11	+.07	+.1136	+.64						24.6	1.25	
Weaning fatness, in	-.04			-.04	-.0029					11.0	.78	
Weanling calf returns, \$/100 ac	4796.66	-410.22	+3946.1585	+2168.48	45.7849		-1657.1723		-172.6731	15.5	1388.45	
Animal returns, \$/100 ac	14087.28			+454.46						5.5	1598.72	
Net returns to land and management, \$/100 ac	6107.29			+1564.40	75.6979					4.5	1346.36	

<sup>a</sup>Values are coefficients of partial regression from the model  $\hat{Y} = \text{year, calf sex, calving date, calf sex} \times \text{calving date, factor 2, factor 2}^2, \text{milk production, milk production}^2, \text{factor 2} \times \text{milk production, factor 2}^2 \times \text{milk production}^2$ .

<sup>b</sup>Nonsignificant ( $P > .10$ ) variables were omitted in final models.

<sup>c</sup>Adjusted R<sup>2</sup> values adjusted for the separate effect of year, calf sex, calving date and calf sex x calving date.

<sup>d</sup>Residual standard deviation.

<sup>e</sup>None of the variables tested in the model were significant ( $P < .10$ ).



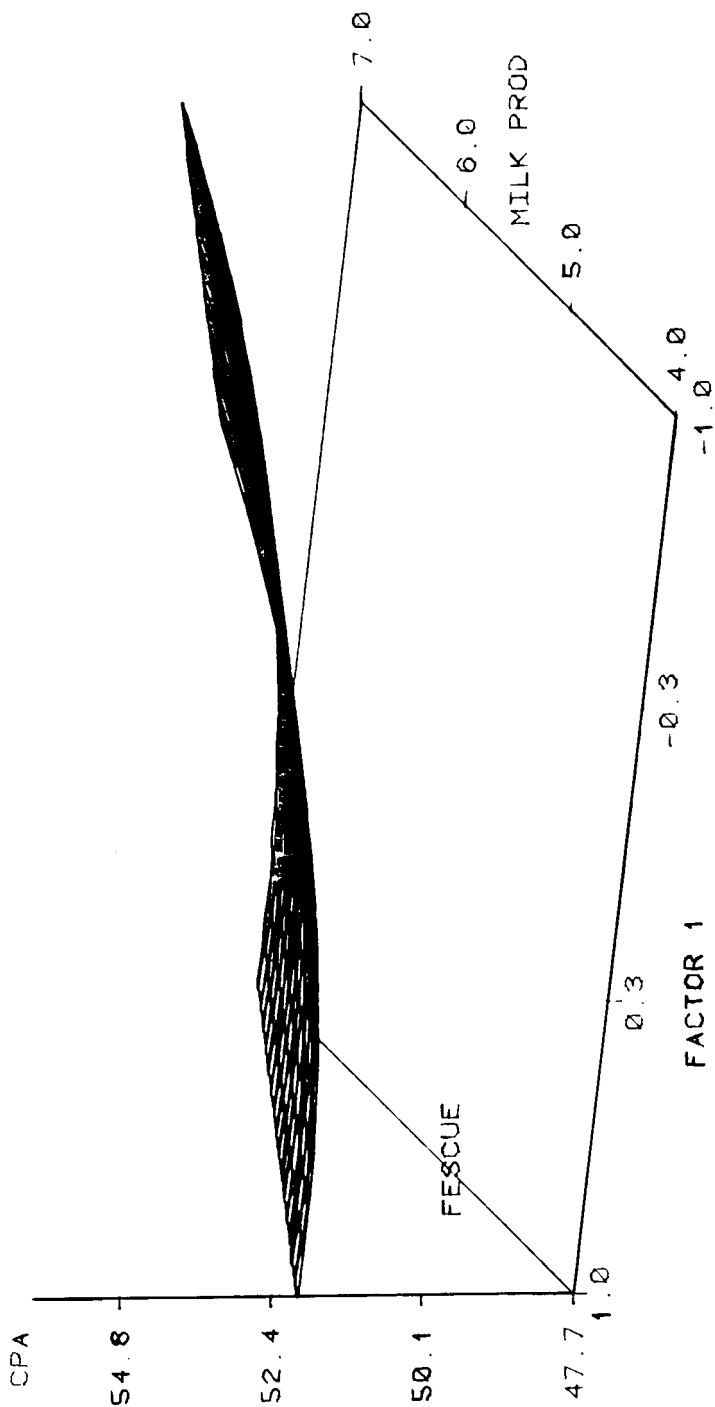

Figure 1. The relationship of frame size (factor 1), milk production (kg/day) and cows/100 acres for cows grazing fescue pasture. CPA = cows/100 acres.

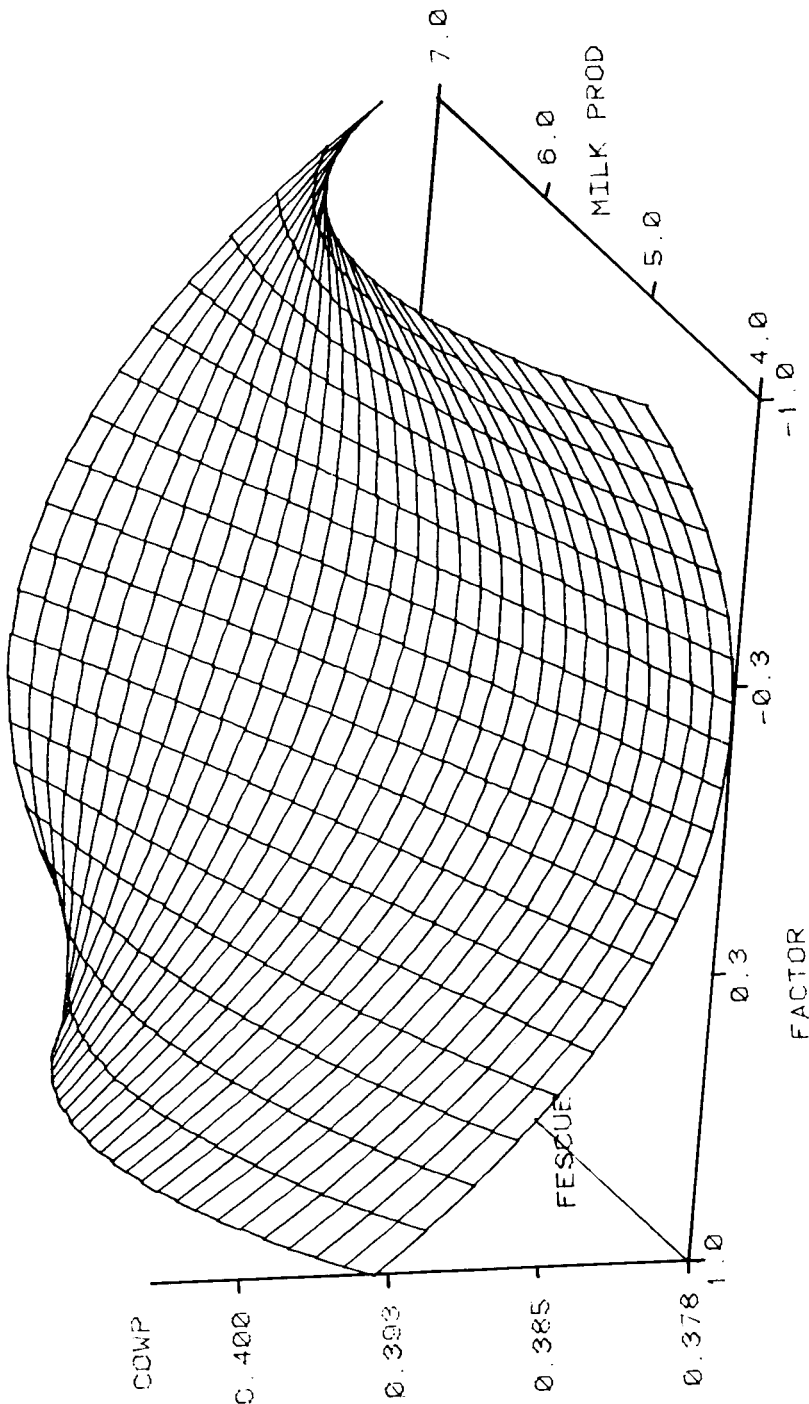

Figure 2. The relationship of frame size (factor 1), milk production (kg/day) and replacement cost (\$/cwt) for cows grazing fescue pasture. COWP = replacement cost (\$/cwt).

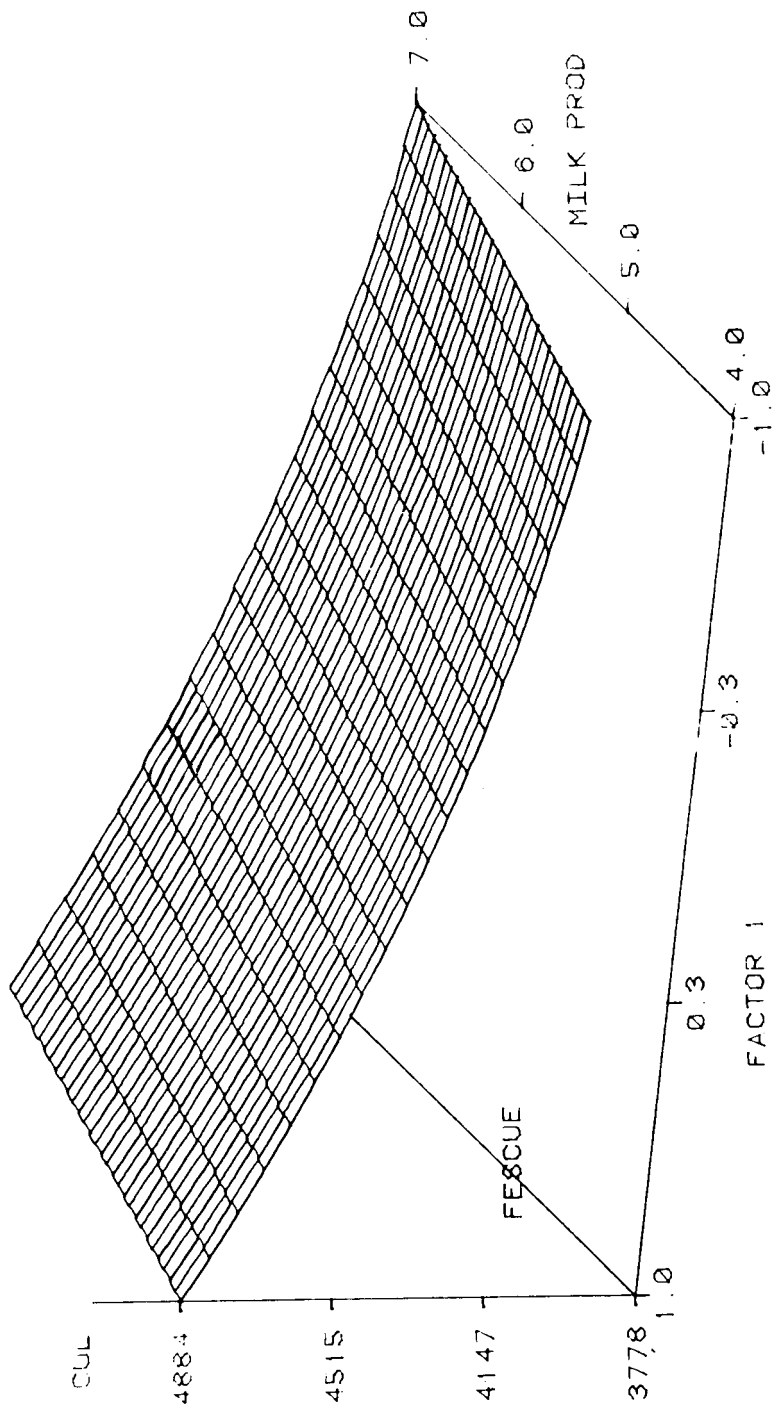

Figure 3. The relationship of frame size (factor 1), milk production (kg/day) and salvage cow returns (\$/100 acres) for cows grazing fescue pasture. CUL = salvage cow returns (\$/100 acres).

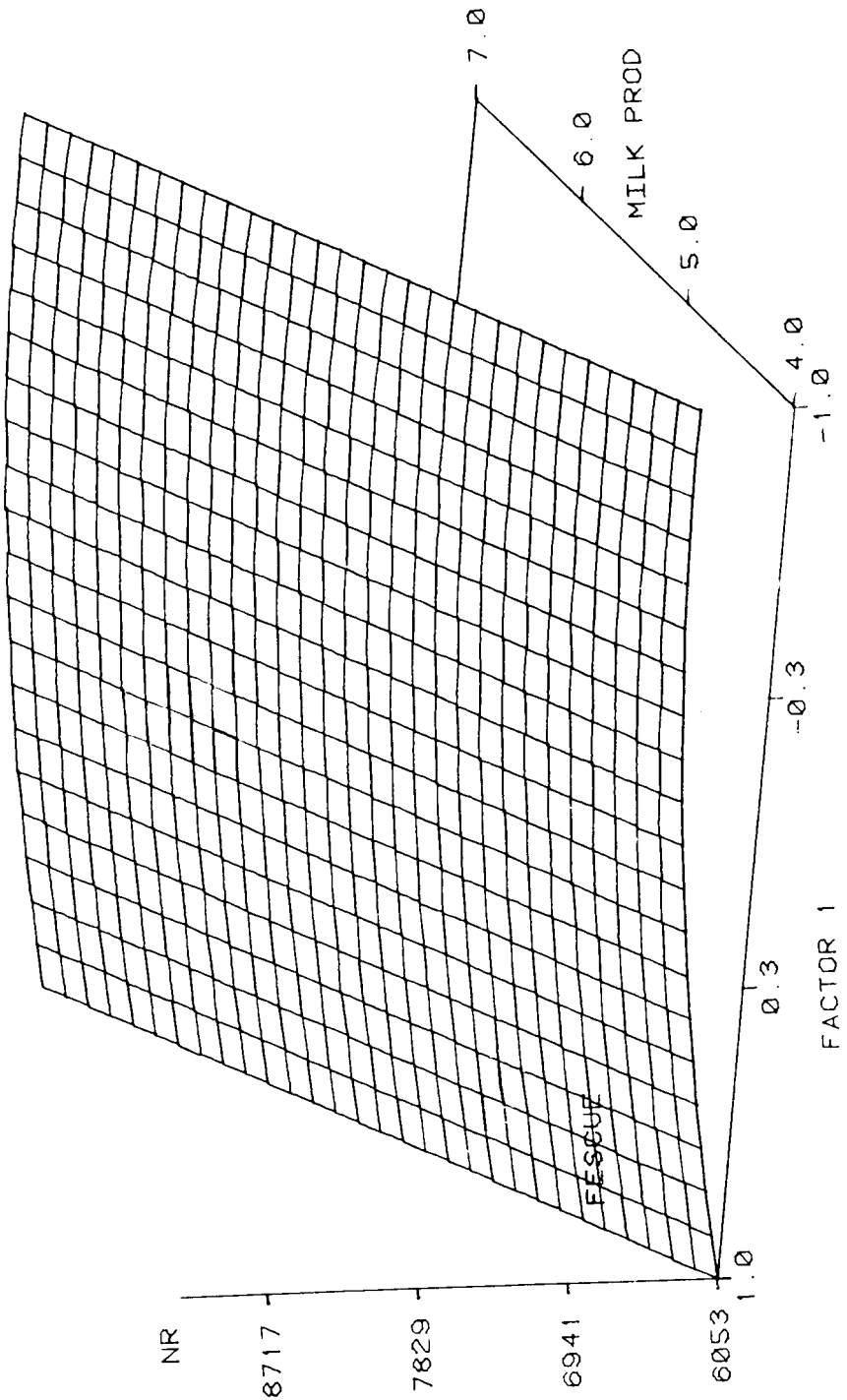

Figure 4. The relationship of frame size (factor 1), milk production (kg/day) and net returns to land (\$/100 acres) for cows grazing fescue pasture. NR = net returns to land and management (\$/100 acres).

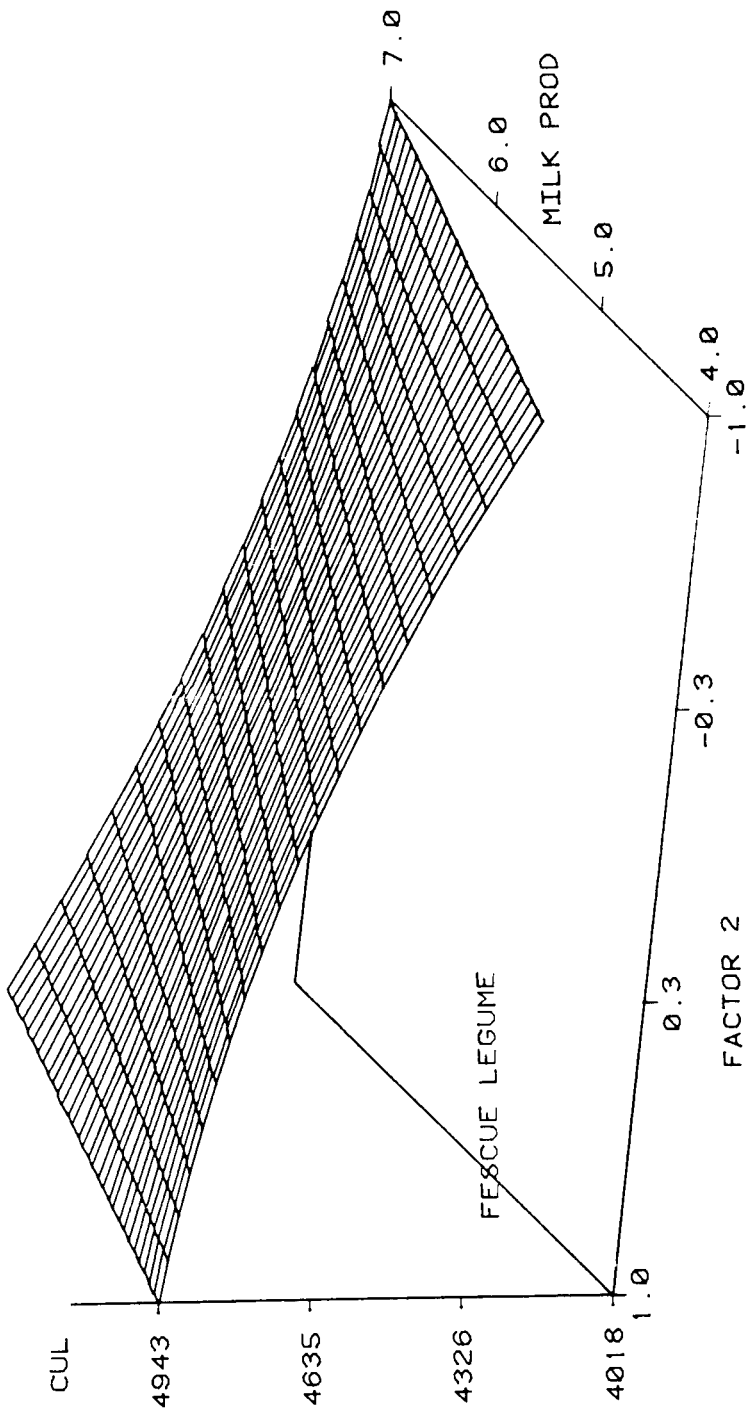

Figure 5. The relationship of fatness (factor 3), milk production (kg/day) and replacement cost (\$/100 acres) for cows grazing fescue-legume. CUL = replacement cost (\$/100 acres).

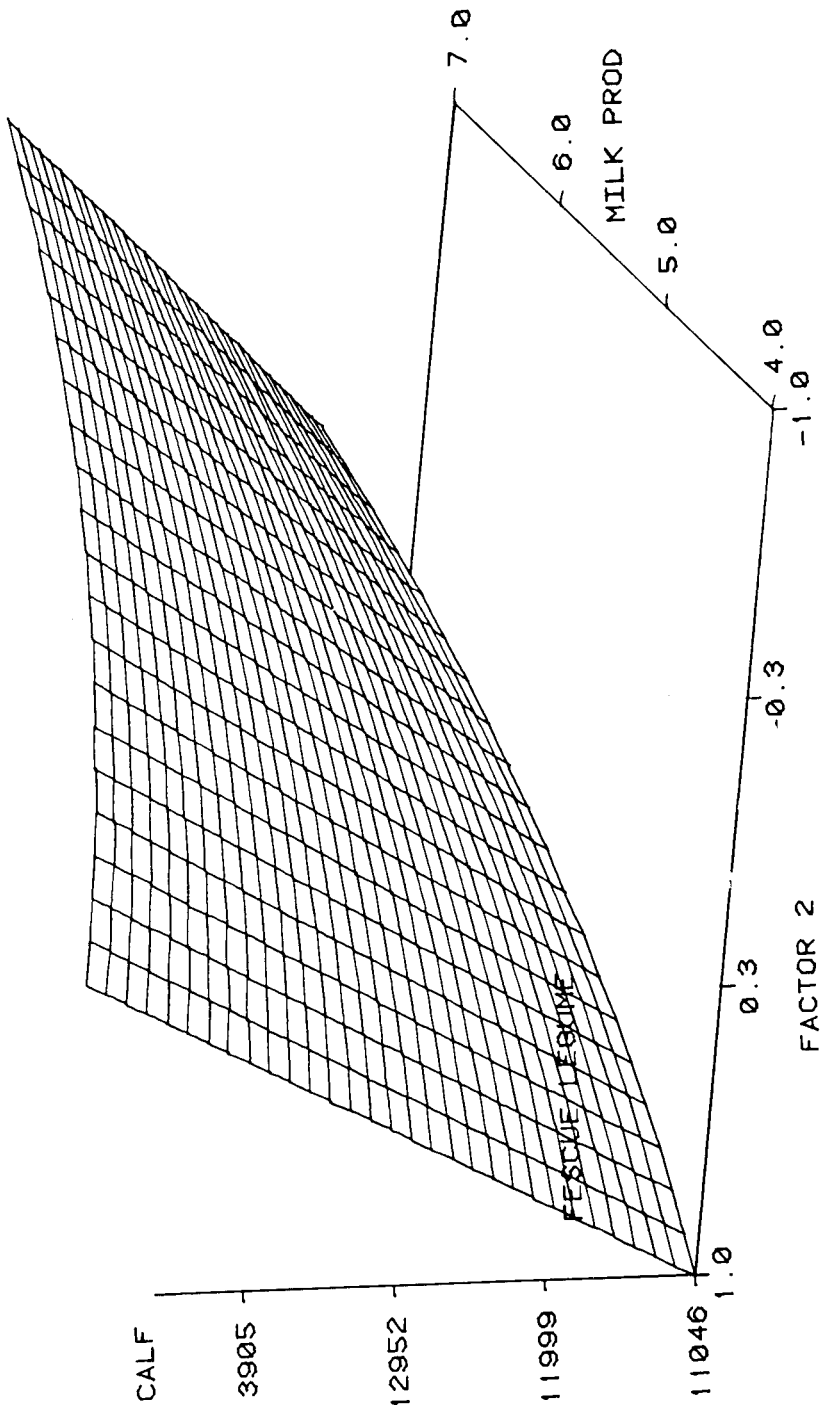

Figure 6. The relationship of fatness (factor 2), milk production (kg/day) and weaning calf returns (\$/100 acres) for cows grazing fescue-legume. CALF - weaning calf returns (\$/100 acres).

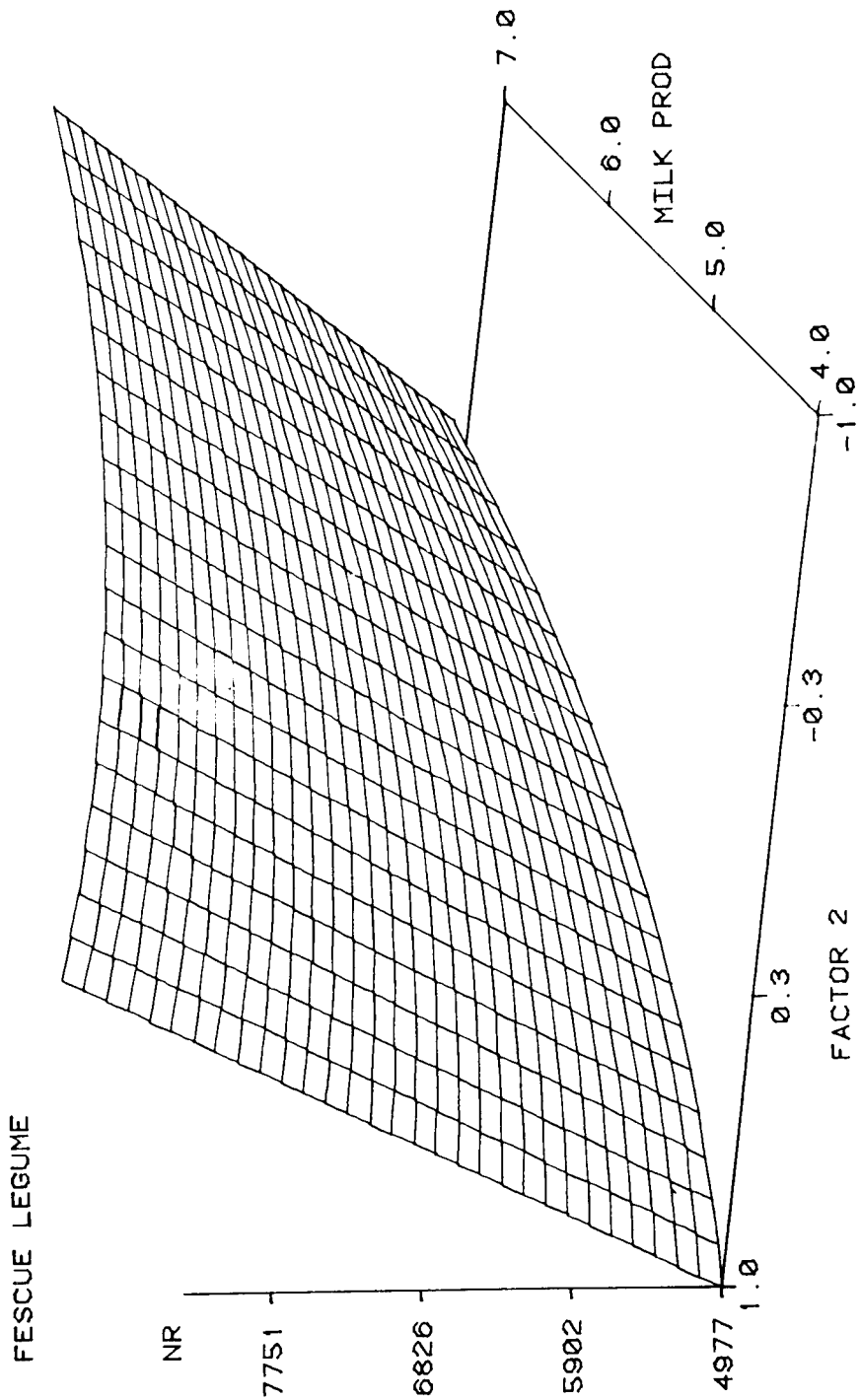

Figure 7. The relationship of fatness (factor 2), milk production (kg/day) and net returns to land (\$/100 acres) for cows grazing fescue-legume. NR = net returns to land and management (\$/100 acres).

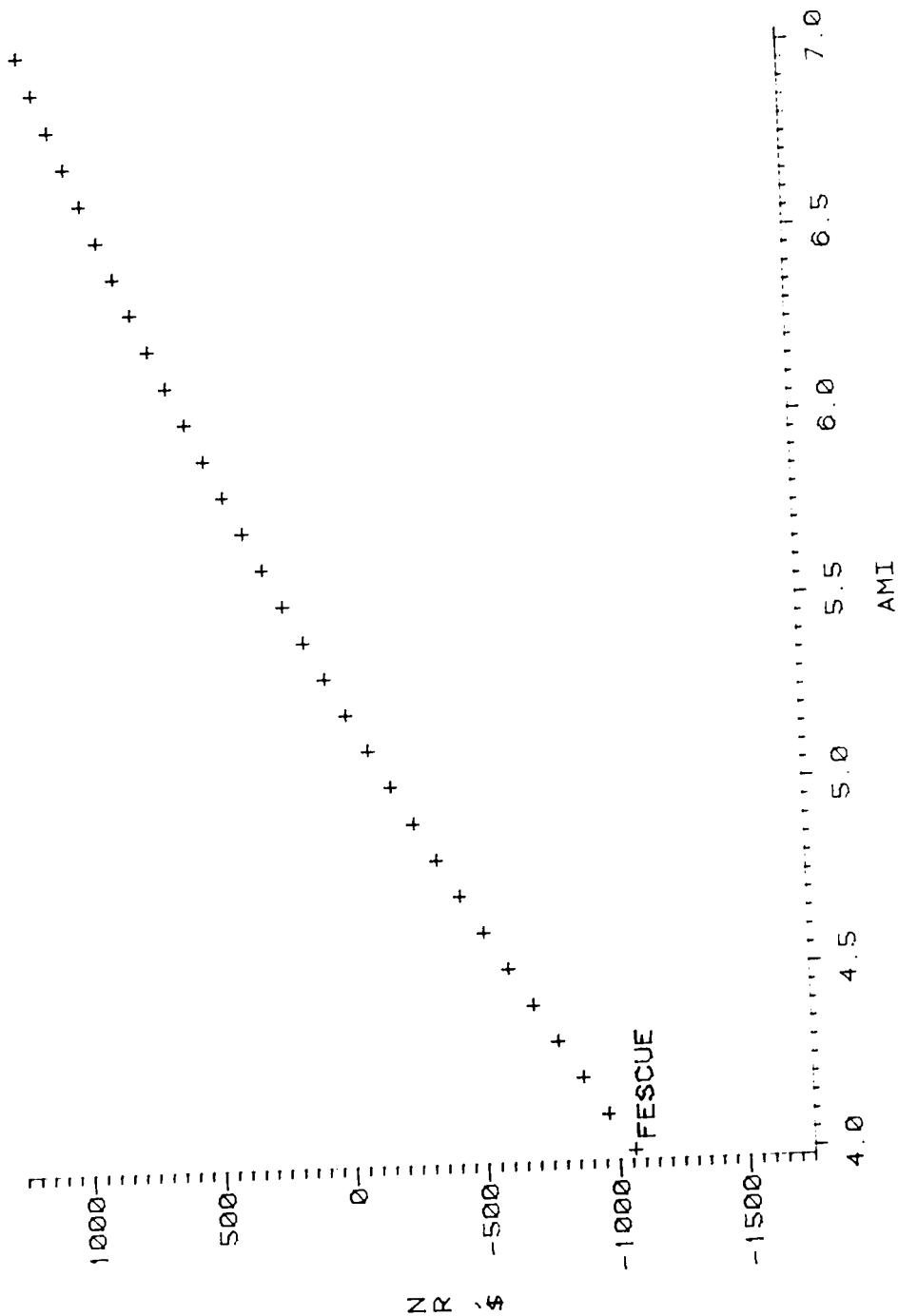

Figure 8. The relationship of fatness (factor 2), milk production (kg/day) and net returns (\$/100 acres) for cows grazing fescue. NR = net returns to land and management (\$/100 acres).



THE UNIVERSITY OF TENNESSEE  
AGRICULTURAL EXPERIMENT STATION  
KNOXVILLE, TENNESSEE 37916

E11-0415-00-001-84

**Agricultural Committee, Board of Trustees**

Edward J. Boling, President of the University;  
William M. Johnson, Chairman;  
William H. Walker, Commissioner of Agriculture, Vice Chairman;  
Jack J. Craddock; James F. Harrison; Ben S. Kimbrough;  
Turner O. Lashlee;  
W. W. Armistead, Vice President for Agriculture

**STATION OFFICERS**

**Administration**

Edward J. Boling, President  
W. W. Armistead, Vice President for Agriculture  
B. H. Pentecost, Assistant Vice President  
D. M. Gossett, Dean  
T. J. Whatley, Associate Dean  
J. I. Sewell, Assistant Dean  
O. Clinton Shelby, Director of Business Affairs  
Fletcher Luck, Director of Services

**Department Heads**

J. A. Martin, Agricultural Economics and Rural Sociology  
D. H. Luttrell, Agricultural Engineering  
D. O. Richardson, Animal Science  
Priscilla N. White, Child and Family Studies  
Carroll J. Southards, Entomology and Plant Pathology  
Betty R. Carruth, Nutrition and Food Sciences  
J. T. Miles, Food Technology and Science  
Gary Schneider, Forestry, Wildlife, and Fisheries  
G. D. Crater, Ornamental Horticulture and Landscape Design  
L. F. Seatz, Plant and Soil Science  
Jacqueline Y. DeJonge, Textiles, Merchandising and Design

**BRANCH STATIONS**

Ames Plantation, Grand Junction, James M. Anderson, Superintendent  
Dairy Experiment Station, Lewisburg, J. R. Owen, Superintendent  
Forestry Experiment Station: Locations at Oak Ridge, Tullahoma, and  
Wartburg, Richard M. Evans, Superintendent  
Highland Rim Experiment Station, Springfield, L. M. Safley, Superinten-  
dent  
Knoxville Experiment Station, Knoxville, John Hodges III, Superintendent  
Martin Experiment Station, Martin, H. A. Henderson, Superintendent  
Middle Tennessee Experiment Station, Spring Hill, J. W. High, Jr., Super-  
intendent  
Milan Experiment Station, Milan, John F. Bradley, Superintendent  
Plateau Experiment Station, Crossville, R. D. Freeland, Superintendent  
Tobacco Experiment Station, Greeneville, Philip P. Hunter, Superintendent  
West Tennessee Experiment Station, Jackson, James F. Brown, Superin-  
tendent