



5-1992

# Wastewater Treatment Plant ChE 490 Design Project

Stephen Lane

*University of Tennessee - Knoxville*

Follow this and additional works at: [https://trace.tennessee.edu/utk\\_chanhonoproj](https://trace.tennessee.edu/utk_chanhonoproj)

---

## Recommended Citation

Lane, Stephen, "Wastewater Treatment Plant ChE 490 Design Project" (1992). *University of Tennessee Honors Thesis Projects*.  
[https://trace.tennessee.edu/utk\\_chanhonoproj/88](https://trace.tennessee.edu/utk_chanhonoproj/88)

This is brought to you for free and open access by the University of Tennessee Honors Program at Trace: Tennessee Research and Creative Exchange. It has been accepted for inclusion in University of Tennessee Honors Thesis Projects by an authorized administrator of Trace: Tennessee Research and Creative Exchange. For more information, please contact [trace@utk.edu](mailto:trace@utk.edu).



College of Engineering  
Materials Science and Engineering  
434 Dougherty Engineering Building  
Knoxville, TN 37996-2200  
(615) 974-5336  
FAX (615) 974-5340

**Wastewater Treatment Plant**

**ChE 490 Design Project**

**Stephen M. Lane**

**Group 8**

Group 8 Members:

Steve Ince

Jay Jackson

Ken Rickett

for Dr. J. Watson

4-20-92

University of Tennessee

Knoxville, TN 37916

## TABLE OF CONTENTS

|                                 |                                |    |
|---------------------------------|--------------------------------|----|
| Design Summary                  | 3                              |    |
| Plant Design Flowsheet          | 4                              |    |
| Plant Design Flowrates          | 5                              |    |
| Process Description             | 6                              |    |
| Major Equipment Sizing          | 8                              |    |
| Major Costing                   | 11                             |    |
| Cost Table                      | 13                             |    |
| Explanation of Cost Table       | 14                             |    |
| References and Acknowledgements | 15                             |    |
|                                 |                                |    |
| Appendix 1:                     | Manufacturer Information       | 16 |
| Appendix 2:                     | Equipment Sizing Calculations  | 30 |
| Appendix 3:                     | Equipment Costing Calculations | 32 |
| Appendix 4:                     | Original Problem Assignment    | 38 |
| Appendix 5:                     | Viewgraph Presentation         | 44 |
| Appendix 6:                     | Additional Information         | 55 |

## **WASTEWATER PLANT DESIGN SUMMARY**

The objective of this assignment was to design a wastewater treatment plant that would remove contaminants from a water stream to satisfy certain limits. The plant was designed for a maximum wastewater flowrate of 300 gpm. Below is a table of the average pollutant concentrations and their agreed discharge concentration limits.

| <u>Pollutant</u>            | <u>Avg. Inlet Conc.</u>             | <u>Outlet Conc.</u> | <u>Limit</u> |
|-----------------------------|-------------------------------------|---------------------|--------------|
| Hg                          | 5 ( $\pm$ 2) ppm                    | < 30                | ppb          |
| trichloroethylene (TCE)     | 20 ( $\pm$ 2) ppm                   | < 1                 | ppm          |
| trichloroethane (TCA)       | 15 ( $\pm$ 5) ppm                   | < 5                 | ppm          |
| total PCBs                  | 20 ( $\pm$ 1) ppm                   | < 5                 | ppm          |
| <u>total organic carbon</u> | <u>150 (<math>\pm</math>10) ppm</u> | <u>&lt; 100</u>     | <u>ppm</u>   |

### **Method of Mercury Removal**

The mercury removal was achieved with the ClariCone clarifier from CBI Walker, Inc. This process uses sulfide precipitation with manganese or sodium. The average inlet and desired outlet mercury concentrations, along with the maximum flowrate, were sent to CBI Walker, which recommended the ClariCone. CBI Walker sent information on the size, shape, and cost of the ClariCone, along with a cost that their company would remove the slurry produced by the process. It was decided that the slurry would be collected and removed every month by Chemical Waste Management.

### **Method of Organics Removal**

Removal of the organics (TCE, TCA, PCB, and OC) was accomplished with activated carbon bed adsorption. Our design uses three beds supplied by Calgon Carbon Corporation. Calgon was sent the inlet and outlet pollutant concentrations and maximum flowrate, and recommended the use of their carbon beds. The first bed is designed for PCB removal. Chemical Waste Management will remove the spent carbon in this bed every six months and Calgon will refill the bed with fresh carbon. The second and third beds are designed for removal of the other organics. These two beds will be removed and refilled by Calgon every other month.

### **Designed Plant Cost**

Our design was estimated to have a total capital investment of \$3,693,750 and a total operating cost of \$1,410,750/yr.

# PLANT DESIGN FLOWSHEET

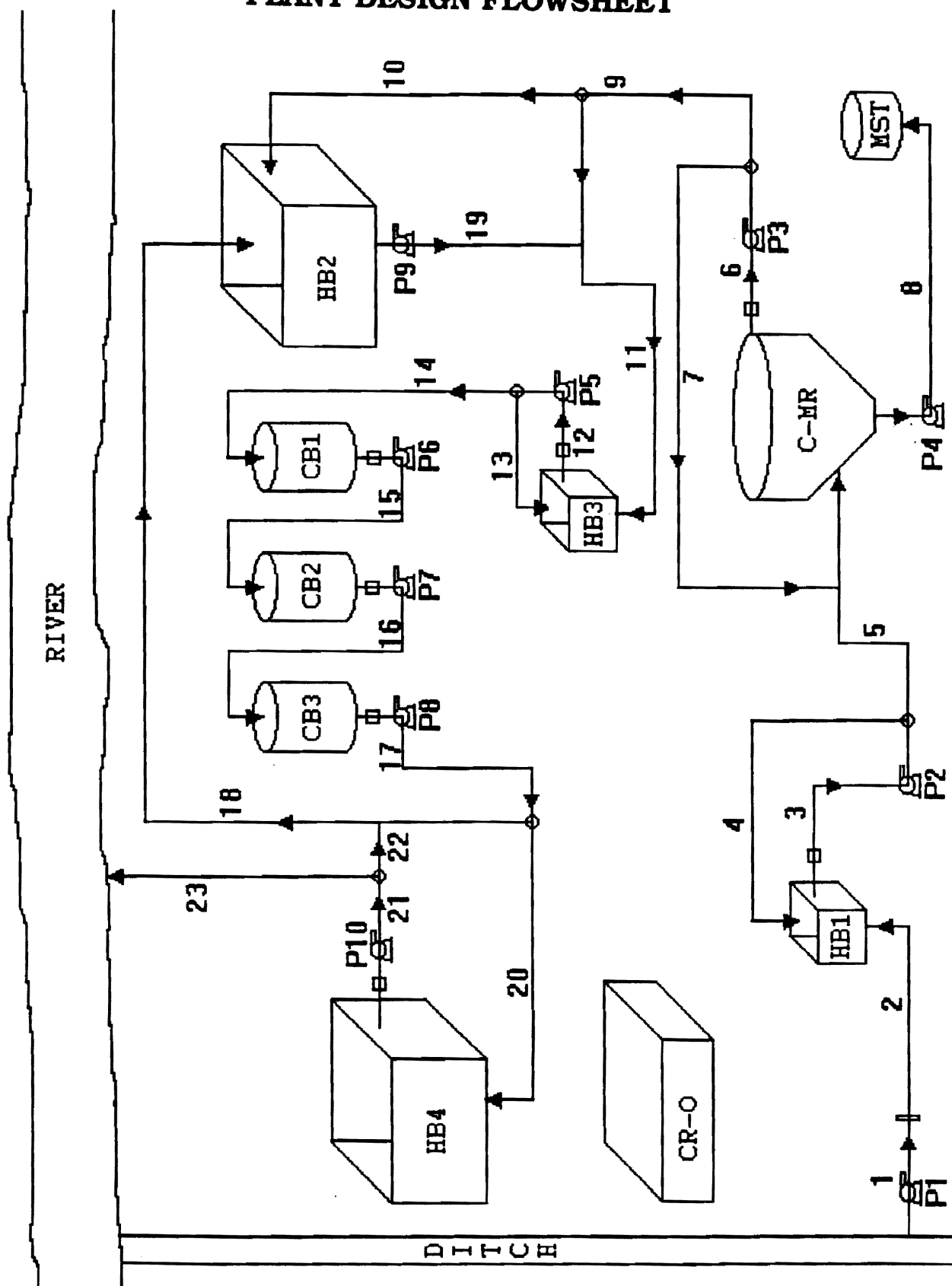

## PLANT DESIGN FLOWRATES

### FLOWRATES OF POLLUTANTS

| STREAM            | 1   | 2   | 3   | 4 | 5   | 6    | 7 | 8    | 9    | 10 | 11   | 12   | 13 | 14   | 15   | 16   | 17   | 18 | 19 | 20   | 21   | 22 | 23   |
|-------------------|-----|-----|-----|---|-----|------|---|------|------|----|------|------|----|------|------|------|------|----|----|------|------|----|------|
| Flow Rate (gpm)   | 300 | 300 | 300 | - | 300 | 300  | - | <1   | 300  | -  | 300  | 300  | -  | 300  | 300  | 300  | 300  | -  | -  | 300  | 300  | -  | 300  |
| Mercury (ppm)     | 5   | 5   | 5   | - | 5   | 0.03 | - | 4.97 | 0.03 | -  | 0.03 | 0.03 | -  | 0.03 | 0.03 | 0.03 | 0.03 | -  | -  | 0.03 | 0.03 | -  | 0.03 |
| TCE (ppm)         | 20  | 20  | 20  | - | 20  | 20   | - | 0    | 20   | -  | 20   | 20   | -  | 20   | 20   | 1    | 1    | -  | -  | 1    | 1    | -  | 1    |
| 1,1,1 TCA (ppm)   | 15  | 15  | 15  | - | 15  | 15   | - | 0    | 15   | -  | 15   | 15   | -  | 15   | 15   | 5    | 5    | -  | -  | 5    | 5    | -  | 5    |
| Total PCB's (ppm) | 20  | 20  | 20  | - | 20  | 20   | - | 0    | 20   | -  | 20   | 20   | -  | 20   | 5    | 5    | 5    | -  | -  | 5    | 5    | -  | 5    |
| Glycerol (ppm)    | 70  | 70  | 70  | - | 70  | 70   | - | 0    | 70   | -  | 70   | 70   | -  | 70   | 70   | 32   | 32   | -  | -  | 32   | 32   | -  | 32   |
| TOC's (ppm)       | 150 | 150 | 150 | - | 150 | 150  | - | 0    | 150  | -  | 150  | 150  | -  | 150  | 150  | 68   | 68   | -  | -  | 68   | 68   | -  | 68   |

**Notes:**

1. < designates less than
2. - means that this stream is only used when test fails

### SIZES OF TANKS, REACTORS, AND PUMPS

1st Holding Tank - pH Adjustment (30 minutes).....1850 sq. ft. (13 ft x 13 ft x 13 ft)

Mercury Precipitator (1.5 - 2 hours detention time).....3900 cu. ft. (d = 26 ft)

2nd Holding Tank - Used During Recycling..(8 hr).....19250 cu.ft. (27 ft x 27 ft x 27 ft)

Activated Carbon Adsorber (2).....715 cu. ft. (d = 10ft, h = 20 ft)

3rd Holding Tank - pH Adjustment (30 minutes).....1850 sq. ft. (13 ft x 13 ft x 13 ft)

4th Holding Tank - Adjust Water Before River..(8 hr).....19250 cu. ft. (27 ft x 27 ft x 27 ft)

Hazardous Waste Storage Tank.....6700 cu. ft. (d = 26 ft, h = 13 ft)

All Pumps Are One Stage, 1750 rpm, VSC (Stainless Steel)

## **PROCESS DESCRIPTION**

This section gives a description of each process used in our design. Each block used in the flowsheet is described below. The blocks are listed in the same order the wastewater stream would flow through in the plant.

### **Holding Basin 1 (HB1)**

After passing through a grit-removal screen, the wastewater stream enters a holding tank. This tank is for adjustment of the stream pH to 8 (by addition of lime), which is necessary for the mercury removal process. The tank is designed for a 30 min residence time.

### **ClariCone Mercury Removal Clarifier (C-MR)**

The ClariCone unit is designed to remove the mercury from the stream with sulfide precipitation. A unit that would handle our mercury concentrations was suggested by CBI Walker, Inc. See Appendix 1 for the actual information CBI Walker sent.

### **Mercury-Removal Waste Storage Tank (MST)**

The slurry waste from the ClariCone is collected in a tank, which will be removed every month by Chemical Waste Management. The tank is designed to hold a blowdown of 250 gal of slurry every 6 hr.

### **Holding Basin 2 (HB2)**

The second holding tank is used to hold the wastewater stream while a carbon bed is being changed. It is designed to hold 8 hr of flow.

### **Holding Basin 3 (HB3)**

The third holding tank adjusts the stream pH to 5 (with HCl) for the carbon beds. It is designed for a 30 min residence time, the same as HB1.

### **Activated Carbon Bed 1 (CB1)**

The first carbon bed is used for PCB adsorption. It was designed by Calgon Corporation. Chemical Waste Management will remove the spent carbon from this bed and Calgon will replace it with fresh carbon every six months.

## **PROCESS DESCRIPTION**

### **Activated Carbon Beds 2 & 3 (CB2,3)**

The second and third carbon beds are used for adsorption of TCE, TCA and organic carbon. They were designed by Calgon, and Calgon will replace their carbon every two months.

### **Holding Basin 4 (HB4)**

The last holding tank collects 8 hr of clean water for adjustment before release into the river. If necessary, the water is adjusted for temperature, oxygen, and pH (6-7) in this tank.



## **MAJOR EQUIPMENT SIZING**

This section gives the sizes of the major equipment used. The calculations used to find these sizes are given in Appendix 2.

### **Holding Basin 1 (HB1)**

The first holding basin is designed to hold the maximum flowrate, 300 gpm, for 30 min. It is a cubic tank with volume of 13500 gal and 12.25-ft sides.

### **ClariCone Mercury Removal Clarifier (C-MR)**

The ClariCone was sized by CBI Walker to meet our mercury removal needs. The size they selected has a top diameter of 26' and a height of 20'4". This size is called "Unit Size 3" by CBI Walker. See Appendix 1 for a schematic of the ClariCone supplied by CBI Walker.

### **Mercury-Removal Waste Storage Tank (MST)**

From information by CBI Walker, the ClariCone will have a 250-gal blowdown every 6 hr for our flowrate and mercury concentration. The MST was designed to hold 30 days of this waste. Its volume is 50000 gal.

### **Holding Basin 2 (HB2)**

When a carbon bed is being replaced, the waste stream is diverted into HB2. It is sized to hold 300 gpm for 8 hr. With these specifications, a 144000 gal cubic tank with 27-ft sides was chosen.

### **Holding Basin 3 (HB3)**

The third holding tank holds the waste stream before entering the carbon beds and adjusts its pH to 5 before entering the carbon beds. It is sized to have a retention time of 30 min for a flow rate of 300 gpm, and will then be the same size as HB1, 13500 gal.

## **MAJOR EQUIPMENT SIZING**

### **Activated Carbon Beds 1-3 (CB1-3)**

The carbon beds that Calgon recommended to us are sized to handle 350 gpm of wastewater with our pollutant concentrations. Their carbon beds have a diameter of 10', a volume of 715 cu.ft, and a height of about 20'. See Appendix 1 for the sizing and other information provided by Calgon.

### **Holding Basin 4 (HB4)**

The final holding tank holds clean water for 8 hr before release into the river. This tank is designed to be the same size as HB2; a 144000 gal cubic tank.

### **Pipe**

The pipe diameter was suggested by Perry's to be 6" for a 300 gpm flow. Schedule 40 pipe was chosen.

### **Pumps (P1-10)**

The ten pumps used in the design are all sized to pump a maximum of 300 gpm through 6" ID pipe with a head of 15-25 ft. The pump type that satisfies these requirements is a centrifugal, one-stage, 1750 rpm, VSC, stainless steel pump.

## MAJOR EQUIPMENT SIZING

### Summary of Equipment Sizes

This is a summary of the equipment sizing. The unit name (as abbreviated in this section and on the flowsheet) is given, along with the unit volume and shape, and the method used to size the unit.

| <u>Unit</u> | <u>Volume, Shape</u> | <u>Source of Sizing</u>            |
|-------------|----------------------|------------------------------------|
| HB1         | 13500 gal cubic      | 300 gpm for 30 min                 |
| HB2         | 144000 gal cubic     | 300 gpm for 8 hr                   |
| HB3         | 13500 gal cubic      | 300 gpm for 30 min                 |
| HB4         | 144000 gal cubic     | 300 gpm for 8 hr                   |
| C-MR        | 3900 cu.ft cone      | Specified by CBI Walker            |
| MST         | 50000 gal rect.      | 250 gal/6 hr for 30 days           |
| CB1-3       | 715 cu.ft cylinder   | Specified by Calgon                |
| P1-10       | 1750 RPM, VSC        | 300 gpm, 6" ID pipe, 15-25 ft head |

## **MAJOR EQUIPMENT COSTING**

This section gives the costs and cost sources for the major equipment and some supply costs. See Appendix 3 for the equipment costing calculations and Appendix 1 for costs of manufacturer-supplied equipment supplies.

### **Holding Basins 1-4 (HB1-4)**

As listed in the previous section, there are 2 13500-gal and 2 144000-gal holding tanks in the plant design. All four tanks were selected to be made out of concrete, the smaller two are shop-fabricated, and the larger two are field-erected. The tanks were costed with Walas and converted to '92 dollars. The total cost of the four tanks is \$87,000.

### **ClariCone Mercury Removal Clarifier (C-MR)**

The ClariCone Size 3 was costed directly from CBI Walker at \$140,000. See Appendix 1 for the price quote.

### **Mercury-Removal Waste Storage Tank (MST)**

The MST was sized at 50000 gal. It is a stainless steel, field-erected tank, and was priced with Walas and converted to '92 dollars. The MST price is \$19,700.

### **Activated Carbon Beds 1-3 (CB1-3)**

The carbon beds were priced directly by Calgon. The first bed (CB1) costs \$70,000, and the other two (CB2-3) cost \$100,000 each. The total cost is \$270,000 for the 3 adsorbers.

### **Pumps (P1-10)**

The 10 centrifugal, 1750 rpm, one-stage, VSC, stainless steel pumps were costed with Walas and converted to '92 dollars. The total cost is \$94,000 for the ten pumps.

## MAJOR EQUIPMENT COSTING

### Carbon Bed Removal and Refill

Calgon will remove the spent carbon from carbon beds 2 and 3, dispose of it, and provide fresh carbon for all three carbon beds. Their cost for providing these services is \$230,000/yr.

The first carbon bed's spent carbon (which will be contaminated by PCB) will be removed by Chemical Waste Management. Their price for doing this is \$9760/yr.

### Mercury Removal

The mercury waste from the MST will be removed every month by Chemical Waste Management. Their cost for this comes to \$66,540/yr.

### Summary of Equipment and Services Costs

| <u>Unit</u> | <u>Description</u>            | <u>Costing Source</u> | <u>Cost</u>       |
|-------------|-------------------------------|-----------------------|-------------------|
| HB1         | Holding Tank                  | Walas                 | \$12,700          |
| HB2         | Holding Tank                  | Walas                 | \$30,800          |
| HB3         | Holding Tank                  | Walas                 | \$12,700          |
| HB4         | Holding Tank                  | Walas                 | \$30,800          |
| C-MR        | ClariCone                     | CBI Walker            | \$140,000         |
| MST         | Hg Waste Storage              | Walas                 | \$19,700          |
| CB1-3       | Carbon Beds                   | Calgon                | \$270,000 (total) |
| P1-10       | Pumps                         | Walas                 | \$94,000 (total)  |
|             | Carbon Bed Removal and Refill | Calgon and CWM        | \$239,760/yr      |
|             | Mercury Waste Removal         | Chem Waste M.         | \$66,540/yr       |

## COST ESTIMATE FOR WASTEWATER TREATMENT PLANT

### CAPITAL COSTS

|   |                |                    |
|---|----------------|--------------------|
| (A) Holding Basins 1-4                    | \$ 87,000      |                    |
| (B) Carbon Beds 1-3                       | 270,000        |                    |
| (C) Pumps 1-10                            | 94,000         |                    |
| (D) Mercury Removal Tank                  | <u>140,000</u> |                    |
| Total =                                   | \$591,000      |                    |
|   |                |                    |
| (PE) Purchased Equipment (A-D)            | \$ 591,000     |                    |
|   |                |                    |
| (E) Installation (=40% PE)                | 236,400        |                    |
| (F) Instrumentation (=15% PE)             | 88,650         |                    |
| (G) Installed Piping (=25% PE)            | 147,750        |                    |
| (H) Installed Electrical (=10% PE)        | 59,100         |                    |
| (I) Building (=10% PE)                    | 59,100         |                    |
| (J) Land (=4 x \$75,000)                  | <u>300,000</u> |                    |
| Total =                                   | \$1,482,000    |                    |
|   |                |                    |
| (DC) Direct Cost (PE + E-J)               |                | \$1,482,000        |
|   |                |                    |
| (K) Engineering Supervision (=25% DC)     | \$ 370,500     |                    |
| (L) Contractors (=25% DC)                 | 370,500        |                    |
| (M) Contingency (=25% FCI)                | <u>732,000</u> |                    |
| Total =                                   | \$1,473,000    |                    |
|   |                |                    |
| (IDC) Indirect Cost (K-M)                 |                | <u>\$1,473,000</u> |
|   |                |                    |
| (FCI) Fixed Capital Investment (DC + IDC) | Total =        | \$2,955,000        |
|   |                |                    |
| (WC) Working Capital (=20% FCI)           |                | <u>738,750</u>     |
|   |                |                    |
| (TCI) Total Capital Investment (FCI + WC) | Total =        | \$3,693,750        |

### OPERATING COSTS

|  |                  |
|--|------------------|
| (N) Operators (2 ops @ \$30000/yr x 4) | \$ 240,000/yr    |
| (O) Chemicals (HCl, CaO, S)            | 7,500/yr         |
| (P) Utilities (=10% FCI)               | 295,500/yr       |
| (Q) Maintenance (=10% FCI)             | 295,500/yr       |
| (R) Taxes (=3% FCI)                    | 88,650/yr        |
| (S) Depreciation                       | 177,300/yr       |
| (T) Activated Carbon (CB-1)            | 9,760/yr         |
| (U) Activated Carbon (CB-2,3)          | 230,000/yr       |
| (V) Mercury Removal Waste Disposal     | <u>66,540/yr</u> |
| Total =                                | \$1,410,750/yr   |

|                                 |                |
|---------------------------------|----------------|
| (OC) Total Operating Cost (N-S) | \$1,410,750/yr |
|---------------------------------|----------------|

## **EXPLANATION OF COST ESTIMATES**

In this section, a brief explanation for our costs is given.

### **Purchased Equipment Costs**

The equipment (HB 1-4, CB 1-3, P 1-10, CM-R) costed are shown on the enclosed flowsheet. The equipment were sized, and then priced with the Walas textbook, Chemical Process Equipment Selection and Design, except for the carbon beds, which were priced directly from the manufacturer. These prices were then converted to 1992 dollars.

### **Other Fixed Capital Investment Costs**

The fixed capital costs were estimated as a percentage (shown on the cost estimate sheet) of either the purchased equipment cost, the direct cost, or the total fixed capital investment. The percentages were obtained from the Peters and Timmerhaus textbook, Plant Design and Economics for Chemical Engineers, Table 26, p. 210. The land cost was based on four acres at \$75,000/acre. The total fixed capital investment was estimated at \$3,693,750, which includes a working capital of \$738,750.

### **Operating Costs**

The operating costs, unless otherwise explained, were calculated as a percentage of the fixed capital investment. The percentages were also obtained from Peters and Timmerhaus. The chemicals were costed with the journal Chemical Marketing Reporter. The depreciation was calculated as  $(FCI - 0.1 FCI)/(15 \text{ yr})$ . The carbon costs were obtained directly from the manufacturer. The total operating cost was estimated at \$1,154,450/yr.

See Appendix 3 for costing calculations, and Appendix 1 for manufacturer information on costing.

## REFERENCES AND ACKNOWLEDGEMENTS

Bannice, Ryan, Eastman Chemical Company

Churn, Cal, Environmental Engineering, Eastman Chemical Company

Havelka, Mike, Calgon Chemical Corporation

McCabe, W.L., Smith, J.C., and Harriott, P., Unit Operations of Chemical Engineering, 3rd ed., 1985

Perry, R.H. and Chilton, C.H., Chemical Engineer's Handbook, 5th ed., 1973

Peters and Timmerhaus, Plant Design & Economics for Chemical Engineers, 4th ed., 1991

Piller, Todd, Product Manager, CBI Walker, Inc.

Smith, Martin, Chemical Waste Management

Walas, S.M., Chemical Process Equipment Selection and Design, 1990

Watson, J., University of Tennessee



**APPENDIX 1**

**MANUFACTURER INFORMATION**



CBI Walker, Inc.

1245 Corporate Boulevard  
Suite 102  
Aurora, Illinois 60504

708 851 7500  
FAX: 708 851 9392

Jay Jackson  
Route 2, Box 88  
Rutledge, TN 37861

Re: CBI Walker ClariCone

Dear Jay:

Enclosed is the information which we discussed last Friday.

Included is a copy of our ClariCone brochure, Installation Listing and Video Tape. Use these as necessary on your design project for Tennessee Eastman.

To confirm our discussion, the following recommendations were made based on the information listed below:

Influent Parameters

300 GPM Flow Rate  
Mercury Removal Application  
Mercury Influent Level - 5 PPM  $\pm$  2 PPM  
Using a sulfide precipitation process w/ Sodium or Manganese

Effluent Parameters

Mercury Level - 30 PPB

Recommendations

Use a 26' diameter, Size 3 ClariCone

Basis

300 GPM design flow, 0.57 GPM/FT<sup>2</sup> surface hydraulic loading rate,  
96 Minutes Detention Time

Budget Pricing

\$ 140,000 total. Excludes taxes and bonds and is based on present day costs with open shop labor.

Scope

Design, fabrication and erection of the following is included by CBI Walker:

- \* Vessel shell, pedestal supported
- \* All internals including concentrator
- \* Bridge beam with carbon steel checker plate and 2 rail handrail across 1/2 the diameter
- \* 3/16" minimum carbon steel material
- \* All Nozzles per typical drawing
- \* Design per AWWA code, 100 MPH wind, zone 1 seismic
- \* Full Burial, 360 degree accessible site
- \* Shop prime painted
- \* Process start-up service

Supplied by CBI Walker for installation by others:

- \* Anchorage, galvanized
- \* Weir plates, steel
- \* Control panel for sludge blowdown and water jet functions only

Excluded:

- \* All field painting
- \* Foundation and grouting
- \* Piping, valves, bolt/gasket sets beyond first flange
- \* Access stairs, ladders or platforms beyond ClariCone
- \* Hydrostatic testing
- \* Erection power
- \* Conduit and wiring

If you have any questions concerning any of the enclosed information please contact us.

Sincerely,

CBI Walker, Inc.



Todd E. Piller, P.E.  
ClariCone Product Manager

cc: J.T. Guthrie - Brentwood, TN  
Attn: Roy Smith



**CBI WALKER**

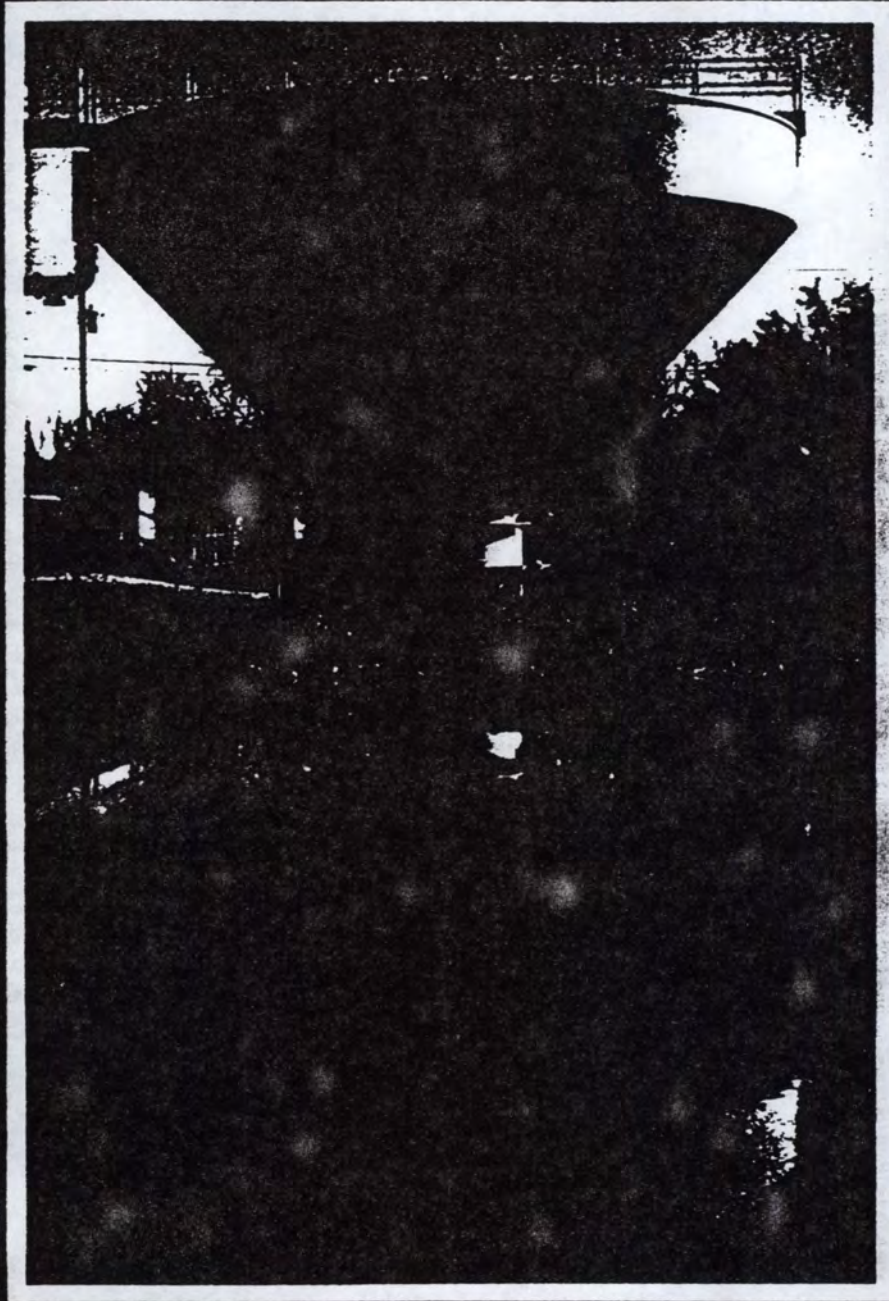

**CLARICONE™**



# THE CLARICONE PROCESS

ClariCone solids contact clarifiers provide state-of-the-art water or wastewater treatment wherever the solids contact process is utilized. The unique, totally hydraulic, helical flow design offers significant operational and maintenance benefits. Numerous consultants who

incorporated ClariCones in their projects received American Consulting Engineers Council (ACEC) Engineering Excellence awards. These installations repeatedly prove the ClariCone to be superior in performance.

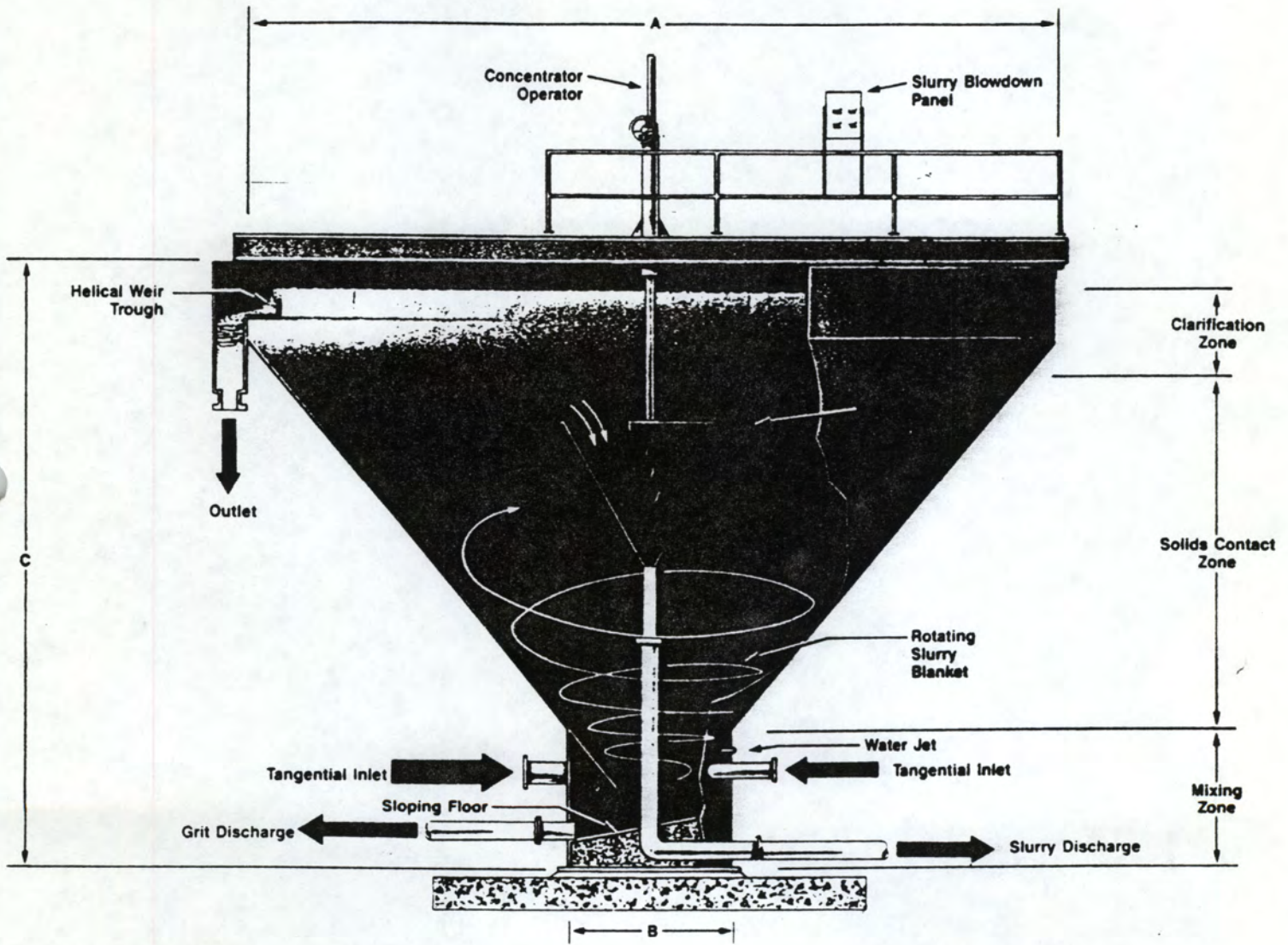

Typical Dimensions

| UNIT SIZE | DIAMETER (A)<br>FT. - IN. | DIAMETER (B)<br>FT. - IN. | HEIGHT (C)<br>FT. - IN. | SURFACE AREA<br>SQ. FT. |
|-----------|---------------------------|---------------------------|-------------------------|-------------------------|
| 0         | 12'-0"                    | 2'-0"                     | 12'-6"                  | 113                     |
| 1         | 15'-0"                    | 3'-0"                     | 12'-6"                  | 176                     |
| 2         | 21'-0"                    | 4'-3"                     | 16'-0"                  | 346                     |
| 3         | 26'-0"                    | 5'-3"                     | 20'-4"                  | 530                     |
| 4         | 30'-0"                    | 6'-0"                     | 22'-11"                 | 706                     |
| 5         | 36'-6"                    | 7'-3"                     | 25'-0"                  | 1046                    |
| 6         | 42'-0"                    | 8'-6"                     | 27'-3"                  | 1385                    |
| 7         | 47'-0"                    | 9'-6"                     | 30'-2"                  | 1735                    |
| 8         | 51'-6"                    | 10'-6"                    | 33'-6"                  | 2083                    |
| 9         | 55'-6"                    | 11'-6"                    | 35'-9"                  | 2419                    |
| 10        | 60'-0"                    | 12'-6"                    | 38'-6"                  | 2827                    |



# APPLICATIONS

## Potable Water Treatment

- Softening
- Turbidity Removal
- Iron Removal
- Color Removal
- Radium Removal
- Algae Removal

## Wastewater Treatment

- Phosphorus Removal
- Filter Backwash Reclamation

## Industrial Process & Waste Treatment

- Boiler Blowdown
- Cooling Water Make-Up
- Suspended Solids Removal
- Coal Pile Runoff
- Ash Handling
- Mining Liquor Clarification
- Landfill Leachate
- Metals Precipitation

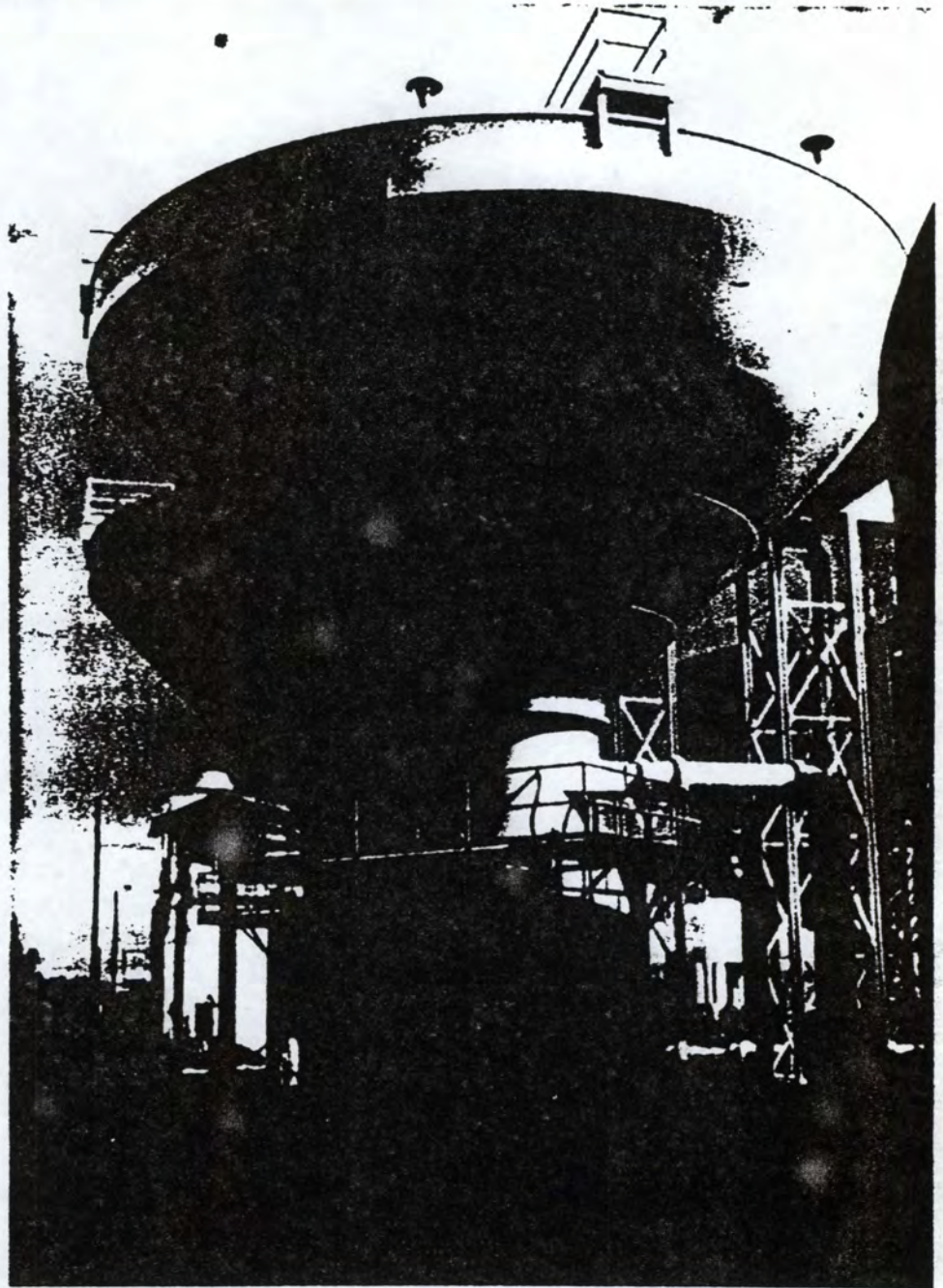

These two 47'0" Claricones which maintain gravity flow through the existing plant are well suited to the restrictive site.



In conjunction with these two 51'-6"  $\emptyset$  lime softening Claricones, CBI Walker provided a Headtank/Trav Aerator assembly for the removal of  $\text{CO}_2$  and

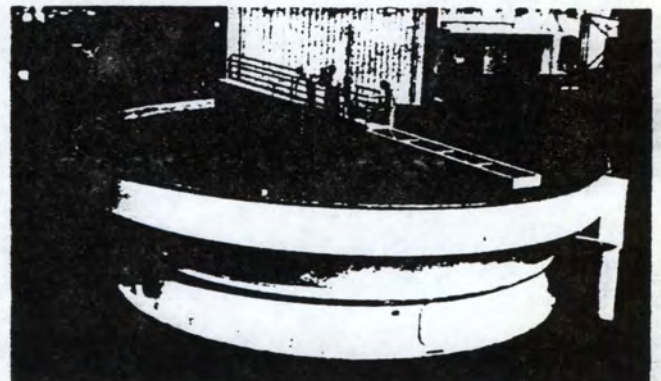

This 60'  $\emptyset$  Claricone is removing iron through a clarification process. Skirt-supported designs are available where the foundation design is



# ADVANTAGES

## Superior Performance

The low effluent turbidities provided by the ClariCone directly measure its high efficiency. Low turbidities, in turn, reduce the load to the filters, resulting in longer filter runs and lower filter operating costs.

## Ideal Hydraulics

The conical shape and helical flow result in ideal flocculation and clarification. Since the ClariCone is a true "slurry blanket" upflow unit, no mechanical recirculation is required.

## High Chemical Efficiency

Cost savings are realized from reduced chemical usage, due to effective solids contact provided through the deep slurry blanket.

## Operational Simplicity

Unlike conventional units, the operator can directly observe the blanket to closely monitor and control performance. Only minor adjustments are required as normal operating procedure.

## Low Maintenance Costs

The ClariCone uses no mixers, scrapers, recycle pumps, or other continuously moving parts, which eliminates the need for oil changes and gear overhauls.

## Adjustable Contact Time

In response to varying raw water conditions, the solids contact time in the ClariCone can be adjusted by simply changing the elevation of the concentrator.

## Low Foundation Costs

The small diameter lower cylinder greatly reduces the required concrete mass and yields a less complex foundation, thereby reducing forming and concrete costs.

## Space Savings

The area beneath the conical shell can be used for other equipment, such as piping, pumps or chemical feeders.

## Stable Operation

The large mass of retained slurry and the unique helical flow characteristics prevent short circuiting and resist upsets due to water quality variations.

## Low Power Usage

Since no motor-driven mechanisms are needed, power costs are negligible.

## Intermittent Operation

Following a shutdown, the ClariCone is restarted in a matter of minutes, compared to hours or days for conventional units. This is ideal for small water plants or non-continuous treatment processes.

## Superior Blowdown System

In-vessel blowdown concentration achieved with the conically shaped concentrator reduces water losses and sludge volumes. The adjustable concentrator permits visual observation and control of the blanket. Blowdown valve failure will not result in slurry blanket loss or cessation of treatment, as is possible in conventional designs. High pressure backflashes which can disturb the blanket are also not required.

## Total Capability

Sole responsibility for design, fabrication, field erection and start-up by CBI Walker assures proven performance and quality.

## Versatility

The ClariCone has a proven track record in a wide range of applications in municipal and industrial water and wastewater treatment. The ClariCone can be interfaced with existing treatment systems and in new plant construction.

## Cost Effective

The bottom line is that the ClariCone provides the most cost effective solids contact process available today.



*These two 36'-6" Ø ClariCones are representative of the many units treating industrial process and waste waters*



*This partially buried 42' Ø ClariCone matches the existing hydraulic profile, in addition to treating turbidity and color, PAC is fed for taste and odor control.*



# CAPABILITIES

- Preliminary Engineering and Process Design
- Equipment Consultation and Recommendations
- Pilot Studies
- Fabrication
- Construction
- Construction Management
- Process Start-Up Services

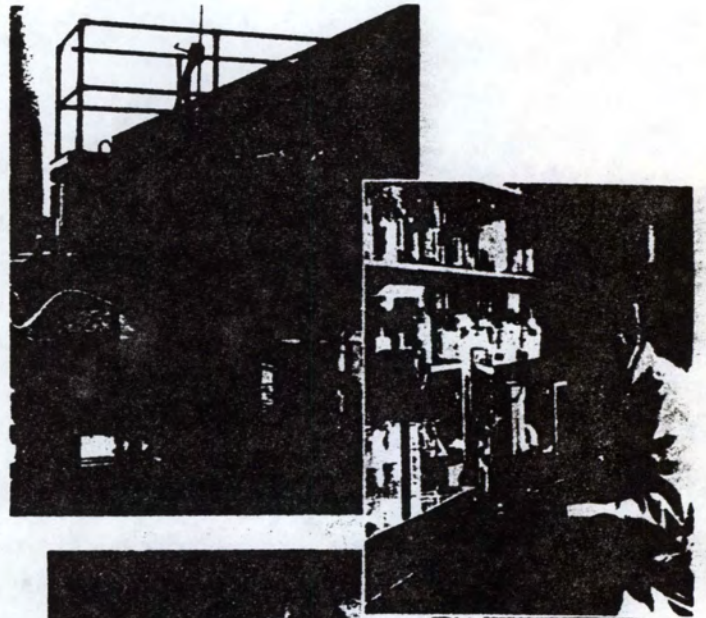



# STATE-OF-THE-ART TECHNOLOGY

The ClariCone is an upflow solids contact process which combines mixing, tapered flocculation and clarification in a completely hydraulic-driven vessel.

A rotating slurry blanket is maintained in suspension by proper control of hydraulic energy. The raw water must pass through this blanket prior to its discharge from the unit. The expanding helical flow pattern accelerates floc formation by providing intimate contact between previously flocculated particles in the blanket and the coagulated material in the raw water.

The **mixing zone** is formed by a cylindrical section. The tangentially oriented inlet nozzles in combination with the cylindrical shape, direct the flow into the helical pattern necessary to provide effective treatment without short circuiting.

**Adjustable velocity control** is provided by the tangential inlet nozzles. By proper control of the hydraulic flow vectors, the rotating blanket is maintained in suspension without allowing floc particles to escape into the clarification zone.

The **solids contact zone** in the conical area continues the helical flow pattern established beneath it. The conical shape provides for a decrease in energy and vertical flow rate as flow progresses upward into the cone.

As a result, ideal tapered flocculation occurs with thorough mixing and gentle flocculation providing floc growth. The extremely long helical flow path, from the bottom through the blanket, has proven to be highly effective, and conventional retention times are unnecessary.

The **slurry concentrator** is the heart of the ClariCone process. The concentrator is centrally located to take advantage of the floc movement toward the quiescent center of the vessel. It is vertically adjustable to allow for changing the blanket depth or solids contact time, to adjust the slurry removal point within the blanket

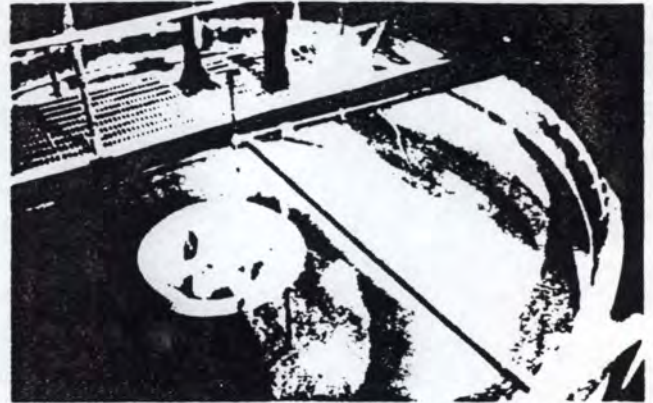

1. The adjustable concentrator in the center of the ClariCone provides slurry concentration and removal. The ClariCone shown above is operated intermittently. The blanket is collapsed into the lower cylinder just prior to start-up.

to maximize slurry concentration, and to permit visual control.

Solids are removed from the rotating blanket by overflowing into the concentrator, and are thickened within the conical shape by compaction. Solids blowdown is accomplished through the vertical downcomer by a timer controlled valve.

The **clarification zone** produces settling dynamics similar to those found in an ideal settling basin. Due to the helical flow, the horizontal flow vector is large and the vertical flow is small, simulating long horizontal flow basins. This provides an extended distance of several hundred feet in the ClariCone in which floc particles can settle. Short circuiting, found in vertical flow basins with flow distances of only ten to fifteen feet from slurry level to the weir, is eliminated in the ClariCone.



2. During the daily start-up, the tangential water jet provides the energy to resuspend and rotate the blanket before introducing the raw water.

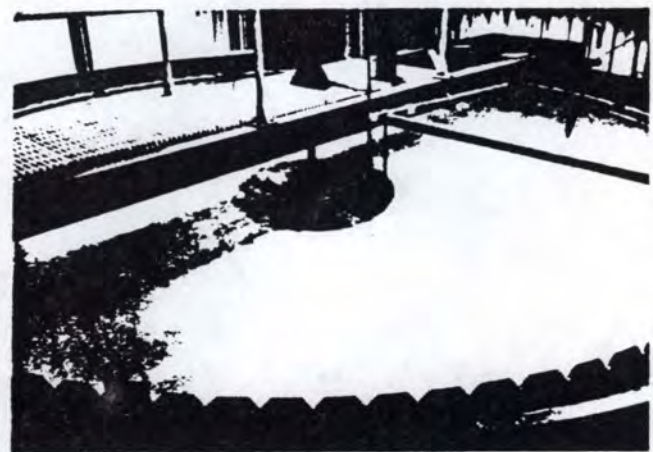

3. About 20 minutes later the blanket is fully resuspended to its operating level. Here, the blanket and concentrator are being viewed through four feet of treated water. This crystal clear water is displaced to the filters during the entire start-up period.



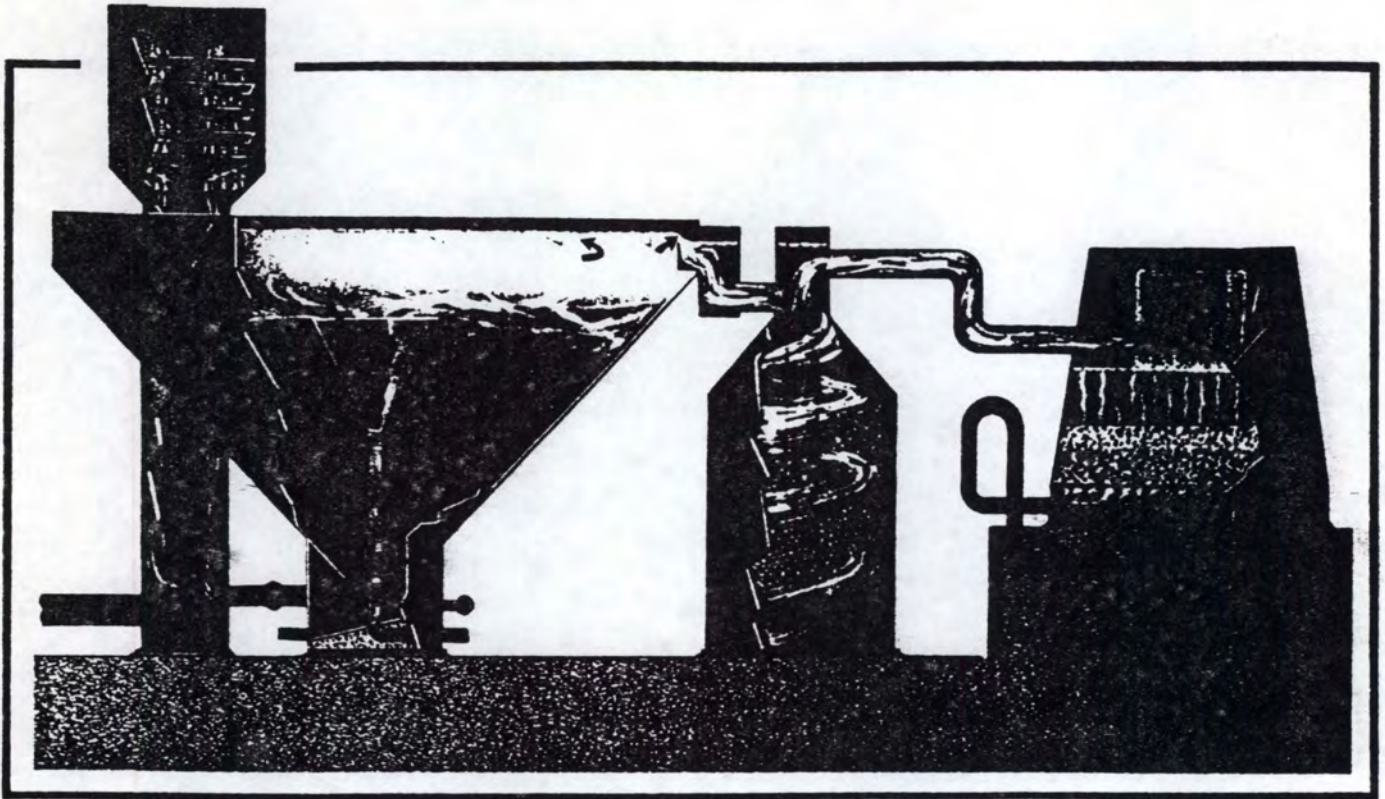

*CBI Walker has supplied the complete water treatment system for numerous plants including the Headtank/Tray Aerator, ClariCone, Helicarb Recarbonation Vessels and Decelerating-Flo Filters.*

In conjunction with the ClariCone™ process, CBI Walker also offers the Helicarb CO<sub>2</sub> Recarbonation system and the Decelerating-Flo Gravity Filter for the most effective water treatment available today.

Sales Representatives are located throughout the United States and Canada. For specific recommendations, or for further information on this product or any other, write or call your local Sales Representative or:



**CBI Walker, Inc.**

1245 Corporate Boulevard  
Suite 102  
Aurora, Illinois 60504  
**(708) 851-7500**  
**FAX: (708) 851-9392**





# MODEL 10 ADSORPTION SYSTEM

# ACTIVATED CARBON PRODUCT BULLETIN

## DESCRIPTION

The Calgon Model 10 Adsorption System has been designed for the removal of soluble organic chemical contaminants from water or wastewater using granular activated carbon products. The system is particularly suitable for applications with low levels of organic contaminants or with flow rates up to 700 gallons per minute per vessel.

The Model 10 unit is a complete water treatment system, skid mounted for ease of installation, and is provided with piping for series or parallel operation. The skid feature allows rapid installation because only the steel skid must be attached to a foundation, while the adsorption vessels and piping are then attached to their proper location on the steel framework.

The Model 10 system is provided with pre-assembled piping sections for influent and treated water, utility water and compressed air, carbon transfer and venting operations. Water and utility piping need only be brought to the Model 10 and connected to complete the installation of the treatment process.

The Model 10 adsorber vessels are ASME coded for 75 psig, lined for corrosion resistance and are designed to contain 20,000 lbs of Calgon Carbon's granular activated carbon. Carbon transfer piping allows use of Calgon Carbon's convenient carbon service including special transfer trailers. At a flow rate of 350 gpm, each adsorber provides 15 minutes contact time.

Your Calgon Carbon Technical Sales Representative can help you evaluate the suitability of the Model 10 to satisfy your requirements. If needed, adsorption evaluation tests or studies to determine applicability and economics can be arranged. Calgon Carbon offers adsorption equipment in many other sizes, and carbon supply and exchange services to meet your particular needs.

## FEATURES

- Proven design—downflow fixed bed adsorption.
- Pre-engineered package—simple and quick installation.
- ASME code vessels compatible with Calgon Carbon Service.
- Vinyl Ester Resin lined vessels suitable for potable water.
- Pipe sizes are designed for the flow rate desired.
- Distributor underdrain for even distribution.
- Manway for maintenance access.
- Backwash capability can be added if suspended solids are present.
- Designed to minimize operating labor and avoid manual handling of carbon.
- Designed for complete removal of exhausted carbon to minimize problems with contaminated material remaining in vessel.
- Capable of bulk carbon filling and removal.
- Granular activated carbon fill and discharge piping.

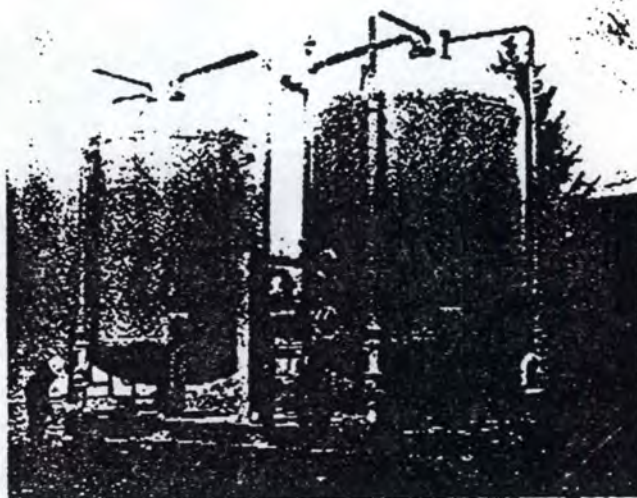

## AVAILABLE AUXILIARY SERVICES

- Calgon Carbon Service

## OPTIONAL OPERATION MODES

- Downflow fixed bed or Downflow fixed bed with backwash capability.
- Series or Parallel flow.

## SPECIFICATIONS

|                           |   |
|---------------------------|---|
| Vessel Diameter:          | 10 ft   |
| ASME Code:                | Design 75 PSIG @ 150° F<br>(higher pressure vessel ratings available)                         |
| Pipe Connections:         | Process pipe: Sized per flow rate;<br>flange connection std.<br>Water pipe: 1-1/2-inch flange |
| Carbon Volume per Vessel: | 715 cu.ft. (nominal 20,000 lbs-granular activated carbon)                                     |
| Weight:                   | Empty—38,000 lbs.;<br>Operating—230,000 lbs.  |
| Pressure Relief:          | 72 PSIG nominal setting   |
| Backwash Rate:            | 1000 GPM (if required)  |
| Transfer Mode:            | Air pressurized slurry transfer   |

## TYPICAL FLOW RATES AND CONTACT TIME

| Series Operation |                      | Parallel Operation |                      |
|------------------|----------------------|--------------------|----------------------|
| GPM              | Contact Time Minutes | GPM                | Contact Time Minutes |
| 350              | 30                   | 700                | 15                   |

NOTE: Smaller Calgon Carbon Service Systems are available for smaller flow rates and lower carbon usage applications.



## MATERIALS OF CONSTRUCTION AND AVAILABLE OPTIONS

- Vessel Lining: Vinyl Ester coating (nominal 40 mil) suitable for potable water and most wastewater applications.
- Piping and Valves: Carbon steel piping and cast iron butterfly valves (process) and stainless steel ball valves (carbon transfer).
- Optional flanged polypropylene lined piping with diaphragm valves for process water.
- Underdrain Collection System: Polypropylene slotted nozzles.
- External Coating: Epoxy Mastic Coating
- Optional polyurethane coating system for more corrosive environments.

## CAUTION

Wet activated carbon preferentially removes oxygen from the air. In closed or partially closed containers and vessels, oxygen depletion may reach hazardous levels. If workers are to enter a vessel containing carbon, appropriate sampling and work procedures for potentially low-oxygen spaces should be followed, including all applicable Federal and State requirements.

*For information regarding human and environmental exposure, call (412) 787-6700 and request to speak to Regulatory and Trade Affairs.*

Calgon Carbon Corporation reserves the right to change specifications without notice for components of equal quality.

*For additional information, contact Calgon Carbon Corporation,  
Box 717, Pittsburgh, PA 15230-0717 Phone (412) 787-6700*



CALGON CARBON CORPORATION

1,1-TCA 15 ppm  
TCE 20 ppm  
PCB's 20 ppm } 150 gpm

For PCB's you can use 5-10% wgt. loading (PCB's - <sup>of PCB's</sup> 26 lb/day @ 150 gpm and 20 ppm). This is conservative per Mick Greenbank loading could be as high as 40%.

GAC Usage for main bed

$3 \text{ lb}/1000 \text{ gal.} \times (150 \text{ gpm}) \times 24 \times 60 = 648 \text{ lb/day} (234,000 \text{ lb/yr.})$

~~NOT~~  
ORGANICS REMOVAL  
REGENERABLE

240,000 lbs GAC/yr

Model 10 Adsorption System - (due to high GAC use Rate)  
• \$ 200,000

\* CARBON COST =  $240,000 \times .65 = 156,000$   
\* NOT INCLUDING FREIGHT.

GLASS BED FOR PCB'S  
NON-REGENERABLE

FREESTANDING  
ONE ADSORBER \$ 70,000

CARBON USE RATE = 40,000 lbs/YEAR

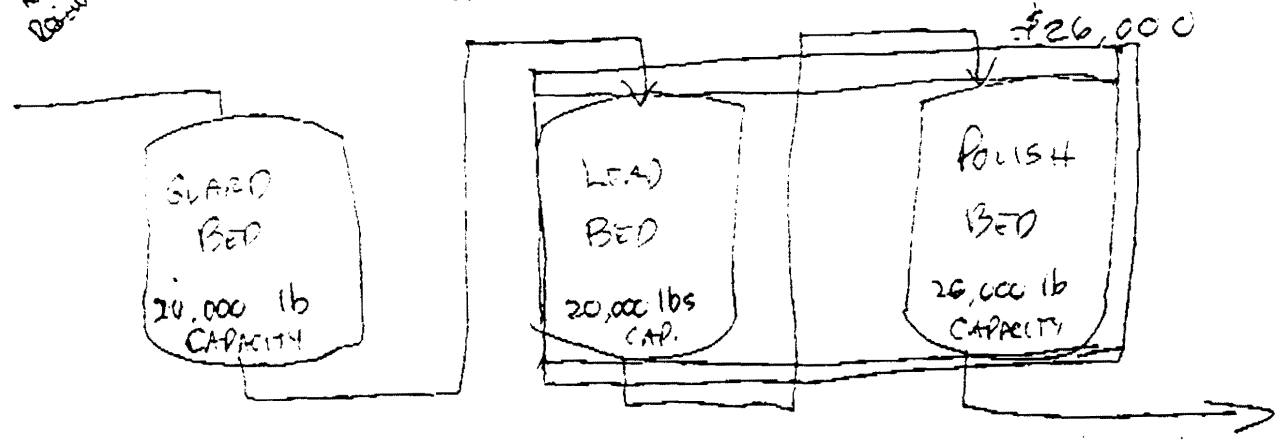

PCB REMOVAL

ORGANICS REMOVAL

INFORMATION FROM CHEM WASTE MAN

PCB Carbon removal

\$245/ton - Carbon disposal (20 ton/yr)

\$1300/shipment

\$113/ton - tax

Mercury removal

\$170/ton - disposal

\$113/ton - tax

\$300 - shipping

} every month, 15 tons  
250000/ton  
every 6 mo.

**APPENDIX 2**

**EQUIPMENT SIZING CALCULATIONS**

## APPENDIX 2: EQUIPMENT SIZING CALCULATIONS

### Holding Basin 1 (HB1)

Tank will hold maximum flow, 300 gpm, for 30 min.

$$V = \frac{(300 \text{ gal/min})(30 \text{ min})}{(7.48 \text{ gal/cu.ft})} = 1203 \text{ cu.ft}$$

Use  $V = 1850 \text{ cu.ft}$  for margin,  $(1850 \text{ cu.ft})^{1/3} = 12.25\text{-ft}$  sides for cubic tank

$$V = (1850 \text{ cu.ft})(7.48 \text{ gal/cu.ft}) = 13500 \text{ gal}$$

---

### Holding Basin 2 (HB2)

Tank will hold maximum flow, 300 gpm, for 8 hr.

$$V = (300 \text{ gal/min})(8 \text{ hr})(60 \text{ min/hr}) = 144000 \text{ gal}$$

$$V = (144000 \text{ gal})/(7.48 \text{ gal/cu.ft}) = 19250 \text{ cu.ft}$$

Use  $V = 19250 \text{ cu.ft}$ ,  $(19250 \text{ cu.ft})^{1/3} = 27\text{-ft}$  sides for cubic tank

---

Calculation for HB3 same as for HB1

---

Calculation for HB4 same as for HB2

---

### Mercury-Removal Waste Storage Tank (MST)

Must hold 250 gal blowdown every 6 hr, for 30 days.

$$V = (250 \text{ gal/blowdown})(4 \text{ blowdowns/day})(30 \text{ days}) = 30000 \text{ gal}$$

Use  $V = 50000 \text{ gal}$  for margin of error.

$$V = (50000 \text{ gal})/(7.48 \text{ gal/cu.ft}) = 6700 \text{ cu.ft}$$

---



**APPENDIX 3**  
**EQUIPMENT COST CALCULATIONS**

### APPENDIX 3: EQUIPMENT COST CALCULATIONS

#### Holding Tanks (HB1-4)

2 13500-gal tanks, concrete, shop-fabricated

From Walas,

$$C = F_m \exp [2.631 + 1.3673 (\ln V) - 0.06309 (\ln V)^2], \quad V \text{ in gal}$$

$$F = 0.55 \text{ (concrete)} \qquad V = 13500 \text{ gal}$$

$$C = (0.55) \exp [2.631 + 1.3673 (\ln 13500) - 0.06309 (\ln 13500)^2]$$

$$C = \$11,300$$

Converting to 1992 dollars, factor is 1.122:

$$C = (1.122)(\$11,300) = \underline{\$12,700}$$

-----  
2 144000-gal tanks, concrete, field-erected

From Walas,

$$C = F_m \exp [11.662 - 0.6104 (\ln V) + 0.04536 (\ln V)^2], \quad V \text{ in gal}$$

$$F = 0.55 \text{ (concrete)} \qquad V = 144000 \text{ gal}$$

$$C = (0.55) \exp [11.662 - 0.6104 (\ln 144000) + 0.04536 (\ln 144000)^2],$$

$$C = \$27,300$$

Converting to 1992 dollars, factor is 1.122:

$$C = (1.122)(\$27,300) = \underline{\$30,600}$$

$$\begin{aligned} \text{Total Cost of 4 Holding Tanks: } C &= 2(\$12,700) + 2(\$30,600) \\ &= \$87,000 \end{aligned}$$

-----

### APPENDIX 3: EQUIPMENT COST CALCULATIONS

#### Mercury Storage Tank (MST)

1 50000-gal tank, stainless steel, field-erected

From Walas,

$$C = F_m \exp [11.662 - 0.6104 (\ln V) + 0.04536 (\ln V)^2], \quad V \text{ in gal}$$

$$F = 0.55 \text{ (concrete)} \quad V = 50000 \text{ gal}$$

$$C = (0.55) \exp [11.662 - 0.6104 (\ln 50000) + 0.04536 (\ln 50000)^2],$$

$$C = \$17,500$$

Converting to 1992 dollars, factor is 1.122:

$$C = (1.122)(\$17,500) = \underline{\$19,700}$$

---

#### Pump Costing (P1-10)

Centrifugal Pumps, 1750 rpm, VSC, one-stage

Stainless Steel,  $Q = 300$  gpm,  $H = 25$  ft head

From Walas,  $C = F_m F_t C_b$ .

$$F_m = 2.00 \text{ (stainless steel)}$$

$$F_t = \exp [5.1029 - 1.2217 (\ln Q \sqrt{H}) + 0.0771 (\ln Q \sqrt{H})^2]$$

$$(\ln Q \sqrt{H}) = (\ln 300 \sqrt{25}) = 7.31$$

$$F_t = \exp [5.1029 - 1.2217 (7.31) + 0.0771 (7.31)^2] = 1.34$$

$$C_b = 1.55 \exp [8.833 - 0.6019 (\ln Q \sqrt{H}) + 0.0519 (\ln Q \sqrt{H})^2]$$

$$C_b = 1.55 \exp [8.833 - 0.6019 (7.31) + 0.0519 (7.31)^2] = 2090$$

$$C = (2.00)(1.34)(2090) = \$5600$$

### **APPENDIX 3: EQUIPMENT COST CALCULATIONS**

Convert to 1992 dollars:  $C = (1.68)(\$5600) = \$9400$

Price for 10 pumps =  $10(\$9400) = \underline{\$94,000}$

---

#### **Carbon Removal and Replacement by Calgon**

Carbon used per year = 240,000 lb (120 tons) by CB2, CB3 and 40,000 lb (20 tons) by CB1 (see Appendix 1)

Fresh carbon will be supplied to all carbon beds, while removal will occur for CB2, CB3 only.

Fresh carbon cost =  $\$156,000/\text{yr} + \$26,000/\text{yr} = \$182,000/\text{yr}$  (see Appendix 1)

Shipping cost =  $\$1300/\text{shipment} = (\$1300)(12 \text{ ships}) = \$15,600/\text{yr}$

Disposal cost =  $\$245/\text{ton} = (\$245)(120 \text{ tons}) = \$29,400/\text{yr}$

Tax =  $\$113/\text{ton} = (\$113)(120 \text{ tons}) = \$13,560/\text{yr}$

Total Cost =  $\$182,000 + \$15,600 + \$39,160 + \$13,560 = \$240,000/\text{yr}$

---

#### **PCB Carbon Removal by Chemical Waste Management**

Carbon used per year = 40,000 lb (20 tons) by CB1 (see Appendix 1)

CWM will remove spent PCB-contaminated carbon from CB1 twice a year.

Carbon Disposal =  $\$245/\text{ton} = (\$245)(20 \text{ tons}) = \$4900/\text{yr}$

Tax =  $\$113/\text{ton} = (\$113)(20 \text{ tons}) = \$2260/\text{yr}$

Shipping =  $\$1300/\text{shipment} = (\$1300)(2) = \$2600/\text{yr}$

Total Cost =  $\$4900 + \$2260 + \$2600 = \$9760/\text{yr}$

## **APPENDIX 3: EQUIPMENT COST CALCULATIONS**

### **Mercury Waste Removal by Chemical Waste Management**

Mercury removed: 15 tons/month, 180 ton/yr (from CWM)

Waste Disposal = \$170/ton =  $(\$170)(180 \text{ tons}) = \$30,600/\text{yr}$

Tax = \$113/ton =  $(\$113)(180 \text{ tons}) = \$20,430/\text{yr}$

Shipping = \$1300/shipment =  $(\$1300)(12) = \$15,600/\text{yr}$

Total Cost =  $\$30,600 + \$20,430 + \$15,600 = \$66,630/\text{yr}$

---

### **Cost Table Calculations**

Note: all percentages were taken from Peters and Timmerhaus, Table 26, p. 210.

### **CAPITAL COSTS**

#### **Purchased Equipment (PE)**

PE = Holding Basins + Carbon Beds + Pumps + Mercury Removal Tank

PE =  $\$87000 + \$270000 + \$94000 + \$140000 = \$591,000$

#### **Other Direct Costs**

Installation = 40% PE =  $40\%(591000) = \$236,000$

Instrumentation = 15% PE =  $15\%(591000) = \$88,650$

Installed Piping = 25% PE =  $25\%(591000) = \$147,750$

Installed Electrical = 10% PE =  $10\%(591000) = \$59,100$

Building = 10% PE =  $10\%(591000) = \$59,100$

Land =  $4 \times \$75000 = \$300,000$

Direct Cost (DC) =  $591000 + 236000 + 88650 + 147750 + 59100$   
 $+ 59100 + 300000 = \$1,482,000$

## APPENDIX 3: EQUIPMENT COST CALCULATIONS

### Cost Table Calculations cont.

#### Indirect Costs:

$$\text{Engineering Supervision} = 25\%DC = 25\%(1482000) = \$370,500$$

$$\text{Contractors} = 25\%DC = 25\%(1482000) = \$370,500$$

$$\text{Contingency} = 25\%FCI = 25\%(2955000) = \$732,000$$

$$\begin{aligned}\text{Total Indirect Costs (IDC)} &= 370500 + 370500 + 732000 \\ &= \$1,473,000\end{aligned}$$

$$\begin{aligned}\text{Fixed Capital Investment (FCI)} &= DC + IDC = 1482000 + 1473000 \\ &= \$2,955,000\end{aligned}$$

$$\text{Working Capital (WC)} = 20\%FCI = 20\%(2955000) = \$738,750$$

$$\begin{aligned}\text{Total Capital Investment (TCI)} &= FCI + WC = 2955000 + 738750 \\ &= \underline{\$3,393,750}\end{aligned}$$

### OPERATING COSTS

$$\begin{aligned}\text{Operators} &= (2 \text{ operators})(\$30,000/\text{yr})(4 \text{ men/operator}) \\ &= \$240,000/\text{yr}\end{aligned}$$

$$\text{Chemicals} = \$7500/\text{yr}$$

$$\text{Utilities} = 10\%FCI = 10\%(2955000) = \$295,500/\text{yr}$$

$$\text{Maintenance} = 10\%FCI = 10\%(2955000) = \$295,500/\text{yr}$$

$$\text{Taxes} = 3\%FCI = 3\%(2955000) = \$88,650/\text{yr}$$

$$\text{Depreciation} = (FCI - 10\%FCI)/(15 \text{ yr}) = \$177,300/\text{yr}$$

$$\begin{aligned}\text{Activated Carbon Removal and Replacement} &= \$230,000 \text{ (Calgon)} \\ &+ \$9760 \text{ (Chem Waste Management)} = \$239,760\end{aligned}$$

$$\text{Mercury Removal Waste Disposal} = \$66,540/\text{yr}$$

$$\begin{aligned}\text{Total Operating Cost} &= 240000 + 7500 + 295500 + 295500 + 88650 \\ &+ 177300 + 230000 + 239,760 + 66540 = \underline{\$1,410,750/\text{yr}}\end{aligned}$$

**APPENDIX 4**

**ORIGINAL PROBLEM ASSIGNMENT**

Jan. 27, 1992

To: Distribution

From: C. E. Prof

New Treatment Plant for Drain and Run-off Water

The company has recently been cited by the state EPA for discharging several pollutants from the northwest portion of our manufacturing complex into the Goodtaste River. At the present time, all floor drains from Buildings A and B discharge into a drainage ditch that runs along the south of both Building A and Building B as shown in Figure 1. Since we originally did not expect any significant pollutants in the buildings, this water is carried in an open rock lined trench into the river. This trench path also receives the near surface flow and surface (storm) water from this area. The floor drains are delivered to the trench by underground pipes, and our Environmental Services Department has been able to monitor the flow in each drain pipe as well as the total trench flow at different points along its length. They estimate that the average flow rates into the trench are as follow.

SOURCES OF WATER IN TRENCH X-78

|                                     |        |
|-------------------------------------|--------|
| Floor Drain (Building A)            | 35 gpm |
| Floor Drain (Building B)            | 15 gpm |
| Storm Drain (around Building A)     | 20 gpm |
| Storm Drain (around Building B)     | 10 gpm |
| Storm Drain (around Receive & Ship) | 20 gpm |

These are average flow rates and not instantaneous rates. Both the floor drains and the storm drains vary considerably, but the floor drain flow over any 24 hour period is essentially the same as the average flow rate. However, the storm drain rate depends greatly upon the weather conditions. The highest rate at the discharge of the trench reported by Environmental Services was 500 gpm, but that is believed to be near the capacity of the trench. If the rainfall is greater, much of the additional flow is believed to flow directly to the river, not through the trench system.

The state has agreed to accept our promise to build a treatment facility that will be capable of handling storm drain rates up to five times the average flow rate. Thus in times of excessively heavy rains, we will be allowed to let storm drain flow rates



greater than this to by pass treatment and go directly to the river.

The contaminants of interest to the regulatory and their concentrations have been monitored by Environmental Services at the point where the trench discharges into the river. They also looked at other components that may be helpful and estimated that the average concentrations are as follow.

#### AVERAGE POLLUTANT CONCENTRATIONS

|                       |                    |
|-----------------------|--------------------|
| Hg                    | 5 (+2) ppm         |
| trichloroethylene     | 20 (+2) ppm        |
| 1,1,1 trichloroethane | 15 (+5) ppm        |
| Total PCBs            | <u>20</u> (+1) ppm |
| Na                    | 50 ppm             |
| Ca                    | 40 ppm             |
| glycerol              | 70 ppm             |
| Total organic carbon  | 150 (+10)ppm       |

The state regulators have asked that we bring these concentration down to the following levels, and our management has agreed to build a facility to meet these goals.

#### AGREED DISCHARGE CONCENTRATION LIMITS

|                       |                    |
|-----------------------|--------------------|
| Hg                    | < 30 ppm           |
| trichloroethylene     | < 1 ppm            |
| 1,1,1 trichloroethane | < 5 ppm            |
| Total PCBs            | < <del>5</del> ppm |
| Total organic carbon  | <100 ppm           |

Environmental Services has also attempted to estimate the average concentration of each stream feeding into the trench. These numbers should be considered less reliable since in addition to the problem with variable flow rates and composition, they were not able to sample the storm drain streams directly.

ESTIMATED COMPOSITION OF WATERS TO TRENCH X-78

| Component | Floor<br>Drain<br>Bldg A | Floor<br>Drain<br>Bldg B | Storm<br>Drain<br>Bldg A | Storm<br>Drain<br>Bldg B | Storm<br>Drain<br>R&S |
|-----------|--------------------------|--------------------------|--------------------------|--------------------------|-----------------------|
| Hg        | <u>10 ppm</u>            | none                     | <u>5 ppm</u>             | <u>1 ppm</u>             | <u>2 ppm</u>          |
| TCE       | 5 ppm                    | <u>100 ppm</u>           | 2 ppm                    | <u>30 ppm</u>            | <u>5 ppm</u>          |
| TCA       | 5 ppm                    | <u>80 ppm</u>            | 1 ppm                    | <u>20 ppm</u>            | 5 ppm                 |
| PCBs      | 500 ppb                  | <u>100 ppm</u>           | 100 ppb                  | <u>10 ppm</u>            | 200 ppb               |
| Na        | 10 ppm                   | 10 ppm                   | 90 ppm                   | 90 ppm                   | 90 ppm                |
| Ca        | 5 ppm                    | 5 ppm                    | 70 ppm                   | 70 ppm                   | 70 ppm                |
| glycerol  | none                     | 400 ppm                  | none                     | 80 ppm                   | 5 ppm                 |
| TOC       | 20 ppm                   | <u>800 ppm</u>           | 10 ppm                   | 20 ppm                   | 20 ppm                |

It is apparent from these studies that the soil surrounding (and possibly under) Buildings A and B and the Receiving and Shipping facilities have been contaminated, and those pollutants are being "picked up" by the surface and near surface storm flows. An eventual option (perhaps a future requirement) will be to remediate the soils within the plant area. However, management has decided that would be too costly at the present time because of the disruption it would cause in the operations in Buildings A and B.

Prepare a conceptional design of optional methods (at least three options) for meeting the emission goals that our management has agreed upon with the state, and then proceed with a preliminary design and cost estimate for one set of process options. Four acres of land are available just south of the Receiving and Shipping facility for you to build your discharge water treatment facility. The track is approximately square in shape. You may use as much of the land as necessary, but it would be desirable to leave as much land as possible for other uses in the future. You will need to include accumulation tanks for at least 8 hours to retain treated water before it is released. This will allow acceptable monitoring of the water before release. You will need longer accumulation for untreated water to account for the large variation in flow caused by weather conditions (rain). Propose both suitable accumulation capacity and methods for holding the accumulation. For costing the discharge water treatment facility, you may value the land used at \$75,000/acre, providing that there is enough remaining land with a sufficiently useful shape for future development.

You can consider two options for approaching the problem. First you may consider building a single plant that would process all of the water currently carried by the trench. For a second option, you may consider treating the two floor drains separate from the storm drains. That approach would require separate facilities and additional piping that should be considered in your design and cost estimate, if you adopt that approach.

Your preliminary design report will be due on Monday May , 1992. Please prepare a schedule for this design study which includes the summary of the conceptual designs that you considered for the problem, their merits and disadvantages, and the basis which you used in choosing the final flow sheet adopted for the preliminary design and cost estimate. Please suggest the milestone schedule which you would like for management to use in monitoring your progress. The milestone schedule should be submitted for discussion with management on Monday Feb. , 1992. The schedule will be reviewed and altered or approved.

2 wks before final design meeting

Conceptual design next wk

3 Concepts 2 wks & recommendation

"Milestone Chart" next wk

PRELIMINARY FLOW SHEET

FINAL FLOW SHEET

CALCULATIONS (FLOWS, COMPOSITIONS)

DESIGN EQUIPMENT

COST ESTIMATE

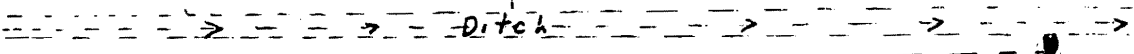
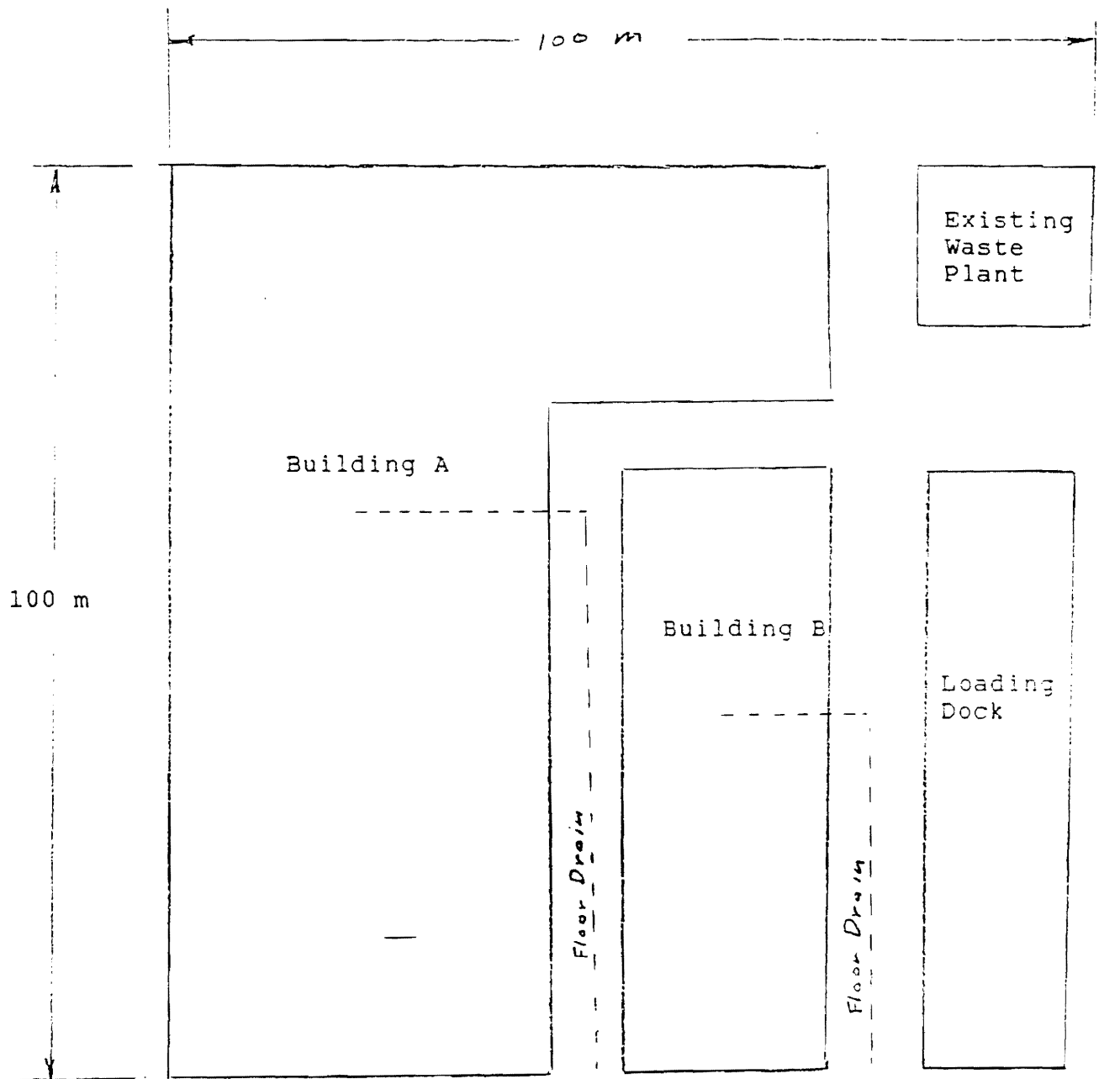

can treat drains separately

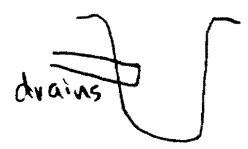

Proposed  
New Waste  
Treatment  
Facility

4 acres = 417 ft  
= 137m

Figure 1  
Layout of Existing Facilities and Proposed Treatment Plant  
(Scale - Approximate)

**APPENDIX 5**

**VIEWGRAPH PRESENTATION**

# **SUMMARY OF WASTEWATER PLANT**

**Objective:** to build a plant that will treat a maximum of 300 GPM of wastewater.

**Wastewater Contaminants:** Mercury, TCE, TCA, PCB

**Method of Mercury Removal:** Claricone clarifier from CBI Walker, Inc. Uses sulfide precipitation process w/ Na or Mn. Slurry discharge will be collected and removed every month by Chemical Waste Management.

**Method of Organics Removal:** Activated carbon beds from Calgon Carbon Corporation. Three beds will be used. The first bed is used for PCB removal, and its spent carbon will be removed by Chemical Waste Management and replaced by Calgon every six months. The other two beds are used for TCE, TCA, and other organic carbon removal, and each bed will be removed and replaced by Calgon every other month. The wastewater will be tested by GC to determine if the carbon needs to be replaced earlier than these times.

**Total Capital Investment:** \$3,693,750

**Total Operating Cost:** \$1,410,750/yr



## FLOWRATES OF POLLUTANTS

| STREAM            | 1   | 2   | 3   | 4 | 5   | 6    | 7 | 8    | 9    | 10 | 11   | 12   | 13 | 14   | 15   | 16   | 17   | 18 | 19 | 20   | 21   | 22 | 23   |
|-------------------|-----|-----|-----|---|-----|------|---|------|------|----|------|------|----|------|------|------|------|----|----|------|------|----|------|
| Flow Rate (gpm)   | 300 | 300 | 300 | - | 300 | 300  | - | <1   | 300  | -  | 300  | 300  | -  | 300  | 300  | 300  | 300  | -  | -  | 300  | 300  | -  | 300  |
| Mercury (ppm)     | 5   | 5   | 5   | - | 5   | 0.03 | - | 4.97 | 0.03 | -  | 0.03 | 0.03 | -  | 0.03 | 0.03 | 0.03 | 0.03 | -  | -  | 0.03 | 0.03 | -  | 0.03 |
| TCE (ppm)         | 20  | 20  | 20  | - | 20  | 20   | - | 0    | 20   | -  | 20   | 20   | -  | 20   | 20   | 1    | 1    | -  | -  | 1    | 1    | -  | 1    |
| 1,1,1 TCA (ppm)   | 15  | 15  | 15  | - | 15  | 15   | - | 0    | 15   | -  | 15   | 15   | -  | 15   | 15   | 5    | 5    | -  | -  | 5    | 5    | -  | 5    |
| Total PCB's (ppm) | 20  | 20  | 20  | - | 20  | 20   | - | 0    | 20   | -  | 20   | 20   | -  | 20   | 5    | 5    | 5    | -  | -  | 5    | 5    | -  | 5    |
| Glycerol (ppm)    | 70  | 70  | 70  | - | 70  | 70   | - | 0    | 70   | -  | 70   | 70   | -  | 70   | 70   | 32   | 32   | -  | -  | 32   | 32   | -  | 32   |
| TOC's (ppm)       | 150 | 150 | 150 | - | 150 | 150  | - | 0    | 150  | -  | 150  | 150  | -  | 150  | 150  | 68   | 68   | -  | -  | 68   | 68   | -  | 68   |

### Notes:

1. < designates less than
2. - means that this stream is only used when test fails

## SIZES OF TANKS, REACTORS, AND PUMPS

1st Holding Tank - pH Adjustment (30 minutes).....1850 sq. ft. (13 ft x 13 ft x 13 ft)

Mercury Precipitator (1.5 - 2 hours detention time).....3900 cu. ft. (d = 26 ft)

2nd Holding Tank - Used During Recycling... (8 hr).....19250 cu. ft. (27 ft x 27 ft x 27 ft)

Activated Carbon Adsorber (2).....715 cu. ft. (d = 10ft, h = 20 ft)

3rd Holding Tank - pH Adjustment (30 minutes).....1850 sq. ft. (13 ft x 13 ft x 13 ft)

4th Holding Tank - Adjust Water Before River... (8 hr).....19250 cu. ft. (27 ft x 27 ft x 27 ft)

Hazardous Waste Storage Tank.....6700 cu. ft. (d = 26 ft, h = 13 ft)

All Pumps Are One Stage, 1750 rpm, VSC (Stainless Steel)



# **PROCESS STEPS**

## **Holding Basin 1 (HB1)**

- **Adjusts pH of wastewater stream to 8 (with quicklime) for mercury removal**

## **Claricone Mercury Removal Clarifier (C-MR)**

- **Supplied by CBI Walker, Inc.**
- **Removes mercury from stream by sulfide precipitation**

## **Mercury-Removal Waste Storage Tank (MST)**

- **Holds waste from C-MR**
- **Waste removed every month by Chemical Waste Management**

## **Holding Basin 2 (HB2)**

- **Holds wastewater stream during replacement of carbon beds**

## **Holding Basin 3 (HB3)**

- **Adjusts pH of wastewater stream to 5 (with HCl) for carbon beds**

## **Activated Carbon Bed 1 (CB1)**

- **Adsorber supplied by Calgon Carbon Corporation**
- **Removes PCB from wastewater stream**
- **Carbon removed every 6 months by Chemical Waste Management and replaced by Calgon**

# PROCESS STEPS

## Activated Carbon Beds 2 & 3 (CB2,3)

- Adsorbers supplied by Calgon Carbon Corporation
- Remove TCE, TCA, OC from wastewater stream
- Each bed's carbon replaced every other month by Calgon

## Holding Basin 4 (HB4)

- Holds clean water for release into the river
- Adjusts pH to 6-7 if necessary, temperature, adds oxygen with fountain

# MAJOR EQUIPMENT SIZING

## Holding Basin 1 (HB1)

- Designed to hold 300 gpm for 30 min
- Cubic tank, 1850 ft<sup>3</sup>(=13500 gal), 12.25-ft sides

## Claricone Mercury Removal Clarifier (C-MR)

- Conical clarifier (see "The Claricone Process")
- Sized by CBI Walker, top D=26', Ht=20'4"

## Mercury-Removal Waste Storage Tank (MST)

- Sized by CBI Walker, 6700 ft<sup>3</sup> (=50000 gal)

## Holding Basin 2 (HB2)

- Designed to hold 300 gpm for 8 hr
- Cubic tank, 19250 ft<sup>3</sup> (=144000 gal), 27-ft sides

## Holding Basin 3 (HB3)

- Designed to hold 300 gpm for 30 min
- Cubic tank, 1850 ft<sup>3</sup>(=13500 gal), 12.25-ft sides

## Activated Carbon Beds 1-3 (CB1-3)

- Sized by Calgon to handle 350 gpm
- Vessel D=10 ft, V=715 ft<sup>3</sup>, H≈20 ft (see "Activated Carbon Product Bulletin")

## Holding Basin 4 (HB4)

- Designed to hold 300 gpm for 8 hr
- Cubic tank, 19250 ft<sup>3</sup> (=144000 gal), 27-ft sides

# THE CLARICONE PROCESS

ClariCone solids contact clarifiers provide state-of-the-art water or wastewater treatment wherever the solids contact process is utilized. The unique, totally hydraulic, helical flow design offers significant operational and maintenance benefits. Numerous consultants who

incorporated ClariCones in their projects received American Consulting Engineers Council (ACEC) Engineering Excellence awards. These installations repeatedly prove the ClariCone to be superior in performance.

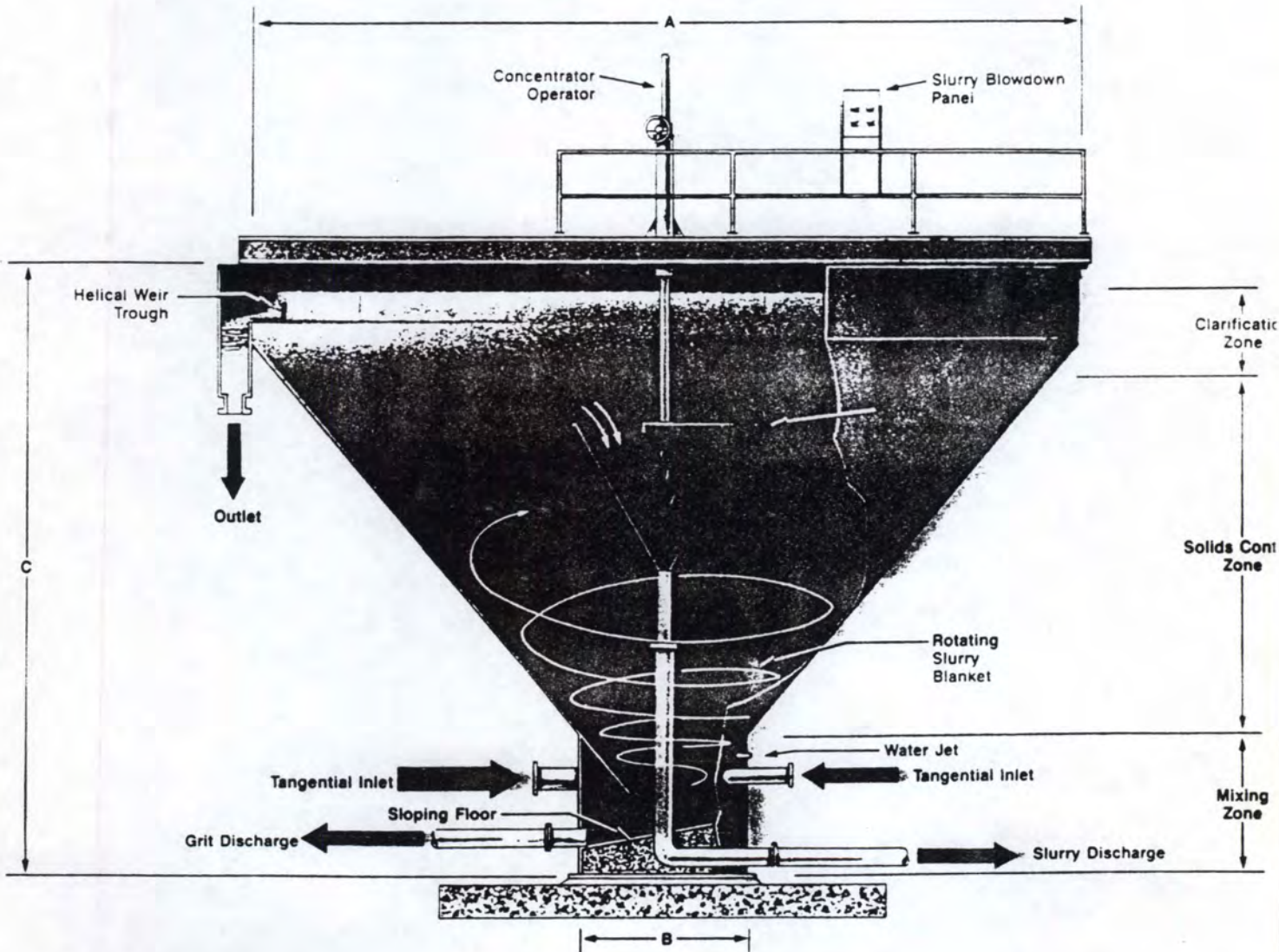

Typical Dimensions

| UNIT SIZE | DIAMETER (A)<br>FT. - IN. | DIAMETER (B)<br>FT. - IN. | HEIGHT (C)<br>FT. - IN. | SURFACE AREA<br>SQ. FT. |
|-----------|---------------------------|---------------------------|-------------------------|-------------------------|
| 0         | 12'-0"                    | 2'-0"                     | 12'-6"                  | 113                     |
| 1         | 15'-0"                    | 3'-0"                     | 12'-6"                  | 176                     |
| 2         | 21'-0"                    | 4'-0"                     | 18'-0"                  | 318                     |
| 3         | 26'-0"                    | 5'-3"                     | 20'-4"                  | 530                     |
| 4         | 30'-0"                    | 6'-0"                     | 22'-11"                 | 709                     |
| 5         | 36'-6"                    | 7'-3"                     | 25'-0"                  | 1046                    |
| 6         | 42'-0"                    | 8'-6"                     | 27'-3"                  | 1385                    |
| 7         | 47'-0"                    | 9'-6"                     | 30'-2"                  | 1735                    |
| 8         | 51'-6"                    | 10'-6"                    | 33'-6"                  | 2083                    |
| 9         | 55'-6"                    | 11'-6"                    | 35'-9"                  | 2419                    |
| 10        | 60'-0"                    | 12'-6"                    | 38'-6"                  | 2827                    |



**DESCRIPTION**

The Calgon Model 10 Adsorption System has been designed for the removal of soluble organic chemical contaminants from water or wastewater using granular activated carbon products. The system is particularly suitable for applications with low levels of organic contaminants or with flow rates up to 700 gallons per minute per vessel.

The Model 10 unit is a complete water treatment system, skid mounted for ease of installation, and is provided with piping for series or parallel operation. The skid feature allows rapid installation because only the steel skid must be attached to a foundation, while the adsorption vessels and piping are then attached to their proper location on the steel framework.

The Model 10 system is provided with pre-assembled piping sections for influent and treated water, utility water and compressed air, carbon transfer and venting operations. Water and utility piping need only be brought to the Model 10 and connected to complete the installation of the treatment process.

The Model 10 adsorber vessels are ASME coded for 75 psig, lined for corrosion resistance and are designed to contain 20,000 lbs of Calgon Carbon's granular activated carbon. Carbon transfer piping allows use of Calgon Carbon's convenient carbon service including special transfer trailers. At a flow rate of 350 gpm, each adsorber provides 15 minutes contact time.

Your Calgon Carbon Technical Sales Representative can help you evaluate the suitability of the Model 10 to satisfy your requirements. If needed, adsorption evaluation tests or studies to determine applicability and economics can be arranged. Calgon Carbon offers adsorption equipment in many other sizes, and carbon supply and exchange services to meet your particular needs.

**FEATURES**

- Proven design—downflow fixed bed adsorption.
- Pre-engineered package—simple and quick installation.
- ASME code vessels compatible with Calgon Carbon Service.
- Vinyl Ester Resin lined vessels suitable for potable water.
- Pipe sizes are designed for the flow rate desired.
- Distributor underdrain for even distribution.
- Manway for maintenance access.
- Backwash capability can be added if suspended solids are present.
- Designed to minimize operating labor and avoid manual handling of carbon.
- Designed for complete removal of exhausted carbon to minimize problems with contaminated material remaining in vessel.
- Capable of bulk carbon filling and removal.
- Granular activated carbon fill and discharge piping.

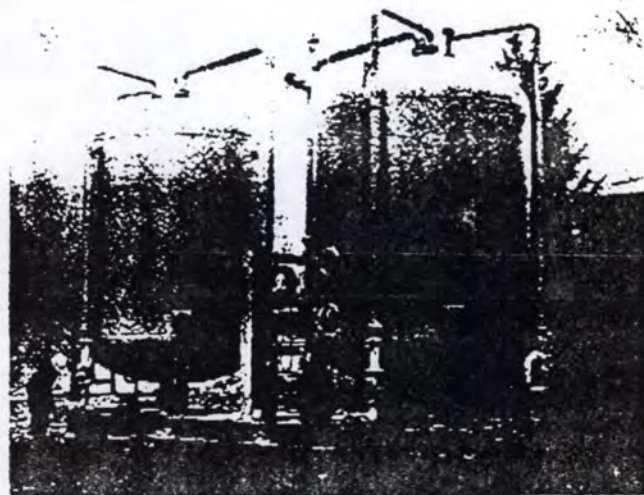

**AVAILABLE AUXILIARY SERVICES**

- Calgon Carbon Service

**OPTIONAL OPERATION MODES**

- Downflow fixed bed or  
Downflow fixed bed with backwash capability.
- Series or Parallel flow.

**SPECIFICATIONS**

Vessel Diameter: 10 ft  
 ASME Code: Design 75 PSIG @ 150° F  
 (higher pressure vessel ratings available)  
 Pipe Connections: Process pipe: Sized per flow rate;  
 flange connection std.  
 Water pipe: 1-1/2-inch flange  
 Carbon Volume per Vessel: 715 cu.ft. (nominal 20,000 lbs-  
 granular activated carbon)  
 Weight: Empty—38,000 lbs.;  
 Operating—230,000 lbs.  
 Pressure Relief: 72 PSIG nominal setting  
 Backwash Rate: 1000 GPM (if required)  
 Transfer Mode: Air pressurized slurry transfer

**TYPICAL FLOW RATES AND CONTACT TIME**

| Series Operation |                      | Parallel Operation |                      |
|------------------|----------------------|--------------------|----------------------|
| GPM              | Contact Time Minutes | GPM                | Contact Time Minutes |
| 350              | 30                   | 700                | 15                   |

NOTE: Smaller Calgon Carbon Service Systems are available for smaller flow rates and lower carbon usage applications.



# **MAJOR EQUIPMENT COSTING**

## **Holding Basins 1-4 (HB1-4)**

- 2 concrete, shop-fabricated, 13500 gal tanks
- 2 concrete, field-erected, 144000 gal tanks
- Costed with Walas and converted to 92 \$
- Total cost of 4 tanks: \$87,000

## **Claricone Mercury Removal Clarifier (C-MR)**

- Cost from CBI Walker: \$140,000

## **Mercury-Removal Waste Storage Tank (MST)**

- Stainless steel, field-erected, 50000 gal tank
- Costed with Walas and converted to 92 \$
- Cost of tank: \$19,700

## **Activated Carbon Beds 1-3 (CB1-3)**

- Cost from Calgon: \$100,000 @ for CB2 and CB3, and \$70,000 for CB1
- Total cost: \$270,000 for 3 adsorbers

## **Pumps (P1-10)**

- Each pump: Centrifugal, 1750 rpm, VSC, stainless steel (to handle 300 gpm through 6" ID, Sch.40 pipe)
- Costed with Walas and converted to 92 \$
- Cost for 10 pumps: \$94,000

## **Carbon Bed Removal and Refill**

- Used carbon will be removed by Calgon and replaced with fresh carbon
- Cost from Calgon: \$239,760/yr for new carbon, shipping, tax for 3 carbon beds

## COST ESTIMATE FOR WASTEWATER TREATMENT PLANT

### CAPITAL COSTS

|   |                                     |                |                     |
|---|-------------------------------------|----------------|---------------------|
| (A)                                       | Holding Basins 1-4                  | \$ 87,000      |                     |
| (B)                                       | Carbon Beds 1-3                     | 270,000        |                     |
| (C)                                       | Pumps 1-10                          | 94,000         |                     |
| (D)                                       | Mercury Removal Tank                | <u>140,000</u> |                     |
|   | Total =                             | \$591,000      |                     |
|   |                                     |                |                     |
| (PE)                                      | Purchased Equipment (A-D)           | \$ 591,000     |                     |
|   |                                     |                |                     |
| (E)                                       | Installation (=40% PE)              | 236,400        |                     |
| (F)                                       | Instrumentation (=15% PE)           | 88,650         |                     |
| (G)                                       | Installed Piping (=25% PE)          | 147,750        |                     |
| (H)                                       | Installed Electrical (=10% PE)      | 59,100         |                     |
| (I)                                       | Building (=10% PE)                  | 59,100         |                     |
| (J)                                       | Land (=4 x \$75,000)                | <u>300,000</u> |                     |
|   | Total =                             | \$1,482,000    |                     |
|   |                                     |                |                     |
| (DC)                                      | Direct Cost (PE + E-J)              |                | \$ 1,482,000        |
|   |                                     |                |                     |
| (K)                                       | Engineering Supervision (=25% DC)   | \$ 370,500     |                     |
| (L)                                       | Contractors (=25% DC)               | 370,500        |                     |
| (M)                                       | Contingency (=25% FCI)              | <u>732,000</u> |                     |
|   | Total =                             | \$1,473,000    |                     |
|   |                                     |                |                     |
| (IDC)                                     | Indirect Cost (K-M)                 |                | <u>\$ 1,473,000</u> |
|   |                                     |                |                     |
| (FCI)                                     | Fixed Capital Investment (DC + IDC) | Total =        | \$ 2,955,000        |
|   |                                     |                |                     |
| (WC)                                      | Working Capital (=20% FCI)          |                | <u>738,750</u>      |
|   |                                     |                |                     |
| (TCI) Total Capital Investment (FCI + WC) |                                     | Total =        | \$ 3,693,750        |

### OPERATING COSTS

|                                 |                                    |                  |  |
|---------------------------------|------------------------------------|------------------|--|
| (N)                             | Operators (2 ops @ \$30000/yr x 4) | \$ 240,000/yr    |  |
| (O)                             | Chemicals (HCl, CaO, S)            | 7,500/yr         |  |
| (P)                             | Utilities (=10% FCI)               | 295,500/yr       |  |
| (Q)                             | Maintainance (=10% FCI)            | 295,500/yr       |  |
| (R)                             | Taxes (=3% FCI)                    | 88,650/yr        |  |
| (S)                             | Depreciation                       | 177,300/yr       |  |
| (T)                             | Activated Carbon (CB-1)            | 9,760/yr         |  |
| (U)                             | Activated Carbon (CB-2,3)          | 230,000/yr       |  |
| (V)                             | Mercury Removal Waste Disposal     | <u>66,540/yr</u> |  |
|                                 | Total =                            | \$1,410,750/yr   |  |
|                                 |                                    |                  |  |
| (OC) Total Operating Cost (N-S) |                                    | \$1,410,750/yr   |  |

**APPENDIX 6**  
**ADDITIONAL INFORMATION**



### **SOME FACTORS INFLUENCING ADSORPTION AT CARBON/LIQUID INTERFACE**

- 1. Attraction of carbon for solute**
- 2. Attraction of carbon for solvent**
- 3. Solubilizing power of solvent for solute**
- 4. Association**
- 5. Ionization**
- 6. Effect of solvent on orientation at interface**
- 7. Competition for interface in presence of multiple solutes**
- 8. Interactions of multiple solutes**
- 9. Coadsorption**
- 10. Molecular size of molecules in the system**
- 11. Pore size distribution in carbon**
- 12. Surface area of carbon**
- 13. Concentration of constituents**

### **INFLUENCE OF MOLECULAR ARCHITECTURE ON ADSORBABILITY**

- 1. Aromatic compounds are in general more adsorbable than aliphatic compounds of similar molecular size**
- 2. Branched chains are usually more adsorbable than straight chains**
- 3. Influence of substitute group is modified by position occupied, e.g., ortho, meta, para**
- 4. Stereoisomers show inconsistent pattern**
- 5. Optical isomers, dextro and levo, appear to be equally adsorbed**

## **SULFIDE PRECIPITATION OF MERCURY**

- **Sulfide addition is the most precipitation treatment used**
- **combined with flocculation and separation by gravity settling**
  - **improves the removal of precipitated mercury sulfide**
  - **do not enhance efficiency of precipitation of soluble mercury**
- **achieves 99.9% removal for high initial mercury levels**
- **minimum effluent mercury achievable appears to be 10-20  $\mu\text{g/l}$**
- **most effective occurs in the near pH range**
  - **efficiency decreases at pH above 9**
- **other drawbacks :**
  - 1) **formation of soluble mercury sulfide complexes at high levels of excess sulfide**
  - 2) **difficulty of monitoring excess sulfide levels**
  - 3) **possible toxic sulfide residual in the treated effluent**
- **using sodium sulfide addition plus filtration (settling), costs are \$0.50/1000 gal (1973)**
- **capital cost for treatment system (1973) is \$959.33/1000 gpd capacity**

① Holding tank - adjust pH  
? - how much lime per pH per volume  
? - time required

② Mercury removal -  
? - amt added  
? - time required for sulfide to form  
? - flow rate + stillness  
? - how to treat

③ Carbon? regeneration time - using 400°C steam

John Baker - 3531  
Medical Bullard - 4039  
Cal Quorn - 3191 (572x)

① Assume no buffer capacity  
- take sample of water + titrate to pH of 1  
- look at equiv of caustic to get there  
- do several titration curves  
- choice between quick lime hyd. lime  
hyd. goes into solution better  
- dissolves faster

(pebble)  
quick - \$60/ton  
hydrated - \$80/ton

• 30 min hold-up will take all into solution  
at 25°C .069 g CaO / L to get to 11.3 in water  
• holding tank well-mixed

.069 g/L  
1136

② Clarifiers built for metal sludges

- sludge blanket up flow  
- create blanket + leave it  
- run influent up through blanket  
- using sludge blanket as filter  
design on bottom

70 g/m<sup>2</sup>  
38000 mg/l

**Wastewater Treatment Plant**

**ChE 490 Design Project**

**Stephen M. Lane**

**Group 8**

Group 8 Members:

Steve Ince

Jay Jackson

Ken Rickett

for Dr. J. Watson

4-20-92

University of Tennessee

Knoxville, TN 37916

**Free Press and Fair Trial:  
A Legal and Ethical Dilemma**

**Tennessee Scholars Senior Project**

**1992**

**Bryan Litfin**



## Outline

### I. Introduction

### II. The Issue

- A. What is at stake?
  - 1. Clash of amendments
  - 2. What to print?
  - 3. Confessions
- B. The journalist's perspective: free press
  - 1. Roots of press freedom
  - 2. Why information should be accessible
- C. The lawyer's perspective: fair trial
  - 1. Roots of fair trial
  - 2. Safeguards for an unbiased jury
  - 3. Responsibility for justice
- D. Summary of the issue

### III. The Legal Aspect

- A. Prejudicial publicity
  - 1. Definition
  - 2. Important cases
- B. Gag orders
  - 1. Definition
  - 2. Important cases
- C. Contempt rulings
- D. Closing the courtroom
  - 1. Definition
  - 2. Important cases
- E. Summary

#### **IV. The Ethical Aspect**

##### **A. Some recent recommendations**

1. From the legal community
  - a. The Reardon report
  - b. The Kaufman report

2. From press-bench-bar organizations

##### **B. Some ethical frameworks**

1. Moral relativism
2. Natural law
3. Utilitarianism
4. Religious ethics

##### **C. A Proposal**

#### **V. Conclusion**

UT journalism professor Dick Smyser, a former president of both the American Society of Newspaper Editors and the Associated Press Managing Editors Association, moderated in 1965 an APME panel discussion on free press and fair trial. He quoted the popular children's rhyme: "Lizzie Borden took an axe/ and gave her mother 40 whacks/ when she saw what she had done/ she gave her father 41." Claiming this was a case of unfair pretrial publicity, he offered a different rhyme: "The Bordens, Emily and Max/ were found dead Tuesday, slain by axe/ The police say 80 blows were sledged/ Their daughter did it, it is alleged." <sup>1</sup>

Professor Smyser's point, of course, was that the trial of Lizzie Borden in 1892 generated so much media attention that it is doubtful she obtained a trial by a truly impartial jury. This issue, which concerns both the right of a free press to cover the news and the right of the defendant to a fair trial, is one that has received much attention in recent years by editors, journalists, judges and attorneys alike. It is not likely to be resolved in the near future.

This paper will address the free press/ fair trial issue from both a legal and an ethical point of view. The perspective will be that of the print reporter, and so the related issue of cameras in the courtroom will not be discussed. Specifically, the paper will deal with the newspaper journalist who might publish something that would bias the public, especially the potential jurors, in a way that would jeopardize the defendant's right to a fair trial.

What is so important about this issue? What are the factors one must take into account? It is important to note that at the basic level, the issue is a constitutional one, and is a clash of the First and



the Sixth amendments. One author asks, "At what point does an accused person's right to a fair, 'speedy and public trial,' protected by the Sixth Amendment ... supersede the right of the American public, and the press as the public's representatives, to be fully informed under the guarantees of the First Amendment?" <sup>2</sup>

Specifically, the question is twofold: what information does the paper publish and when does it publish it? <sup>3</sup> One study found 98 percent of papers will publish the person's name and the charge he is faced with. <sup>4</sup> From there, in order of increasing reluctance to publish are: details of arrest (13 percent withheld the information); criminal record (50 percent withheld); statements by the accused (64 percent); witness testimony (65 percent); and guilty plea bargaining (74 percent). After the newspaper has decided what to publish, it must also decide if it will release the information before, during or after the trial.

Another important type of information is confessions made by the accused. In the case of *Rideau v. Louisiana* (which will be more fully discussed later in the paper), the defendant was interrogated on camera by the sheriff, and he confessed to bank robbery, kidnapping and murder. The interrogation subsequently aired on local TV, causing Rideau's attorneys to claim their client's right to a fair trial was jeopardized. Newspapers must weigh the effects of publicizing such confessions, for they are particularly likely to prejudice the public.

It should be noted that the free press/ fair trial issue involves two communities, and one is partial to a free press while the other is concerned primarily with a fair trial. <sup>5</sup> From the journalist's point of

view, a free press is a vital part of society, and rarely (if ever) should this right to print be abrogated. Of course, a free press is also important to lawyers and judges, just as reporters value a fair trial; but each community has its soap box, and feels "their" amendment is more crucial.

Journalists can claim a long history of press freedom in this country. Those who shaped the Constitution and its underlying values held to the Miltonian principle that all ideas should be allowed to enter the public forum. Various cases through legal history have again and again supported the right of the press (and by implication, other media) to print without fear of prior restraint or punishment. As Donald M. Gillmor, author of Free Press and Fair Trial, notes: "Freedom of speech and press as social rights are the keystone of an open society, the freedoms that best guarantee against the destruction of all other rights." <sup>6</sup>

There are at least three reasons why the journalist believes what goes on in the courtroom should be information to which they have access. First, the reporter usually affirms the concept of any government or official proceeding as being public. To further this idea, journalists and their interest groups have supported "sunshine laws." These regulations require such "official" meetings to be open, whether to the press or the public in general. In the same vein, the federal Freedom of Information Act has also allowed journalists access to government documents.

Second, one may say that journalists often feel they are on an altruistic mission to serve the public. They often speak of the public's "right to know" certain kinds of information. <sup>7</sup> Since society

is so large and diversified, it would be impossible for every citizen to attend every sort of government function. Thus, the press must be the public's eyes and ears to maintain a well-informed populace. With such a responsibility on its shoulders, the press affirms its right of access to courtroom proceedings.

A third reason is perhaps less noble. Very often, the public loves to hear the details of sensational crimes and their accompanying trials, and the newspapers realize covering such trials is good for business. One only has to look at the recent rash of sensationalized trials, from Noriega to Dahmer to Kennedy-Smith to Tyson, to see this phenomenon. The public has an interest in such trials in particular (as to why, this writer will not speculate), and newspaper coverage can generate reader interest. In a time of increased media competition, this can be vital to newspapers, although some editors may wish it were otherwise.

The legal community, on the other hand, sees achieving justice through a fair and speedy system of trial and appeals courts as their primary concern. They too can claim a long history of striving for their noble cause. Gillmor notes that when the colonists came to this country, they brought with them the concept of trial by jury. He writes: "The Sixth Amendment guarantees to all persons accused of a crime a trial by an impartial jury, which, by implication, reaches its verdict solely upon the facts submitted to it by the court." <sup>8</sup> In other words, the United States has always been committed (at least in theory) to the concept of a fair trial.

Lawyers and judges, in their concern for the rights of the individual, have instituted several safeguards to ensure that the jury

will not be biased. <sup>9</sup> Prior convictions are not told to the jury. The jurors are instructed not to discuss the case among themselves. The defendant has the right not to incriminate himself. Hearsay is not permitted in the courtroom, and only those who touched or participated in the events are allowed to function as witnesses. Such provisions as these assure, at least to some degree, that the jury of one's peers before which one is tried will not make its decision based on anything but the facts of the case.

Those in the legal profession feel the weight of responsibility to the public in the same way as journalists. Their responsibility, however, is not the "public's right to know" but rather the "individual's right to justice." The American Bar Association asserts "that the primary burden for ensuring fair trial rests on the legal branch and the agencies which serve and minister to it," and to some extent "the streams of justice which should be clear are made less so by the news media, whose task it is to keep the people informed." <sup>10</sup>

So it is that one must see the issue of fair trial and free press as two conflicting concepts, each of which is a high value. As Sam Ragan, a former APME president notes, "the two are not arrayed against each other. They are not incompatible, for there cannot be a fair trial without a free press." <sup>11</sup> And yet the two, while not always being mutually exclusive, do come into conflict many times in actual practice. The conflict is perhaps inherent in the U.S. Constitution. Herein lies the heart of the matter. When faced with two concepts, both highly valued in society, where does one draw some lines? As shall be demonstrated, the question poses both legal and ethical dilemmas for all involved.

The legal aspect of the issue of pretrial publicity involves case law for the most part, especially three major cases: Irvin v. Dowd, Rideau v. Louisiana, and Sheppard v. Maxwell. These will be discussed in turn. A fourth case, Estes v. Texas, will also be mentioned because of its significance, but it deals with the issue of cameras in the courtroom so it will not be given extensive treatment.

The ABA lists six factors in what may be considered a good definition of pretrial publicity with the ability to cause prejudice.<sup>12</sup> They are (1) criminal records of the defendant or opinions on his character; (2) a confession by the defendant; (3) the results of any test (i.e., a lie-detector) or the defendant's refusal to take a test; (4) the identity, testimony or credibility of a witness; (5) the possibility of a guilty plea; and (6) opinions as to guilt or innocence or statements about the merits of the case or its evidence. The ABA began forming such definitions and guidelines in the wake of the sensationalism surrounding the arrest of Lee Harvey Oswald and the cases mentioned above, the first of which was Irvin v. Dowd.

In 1954 and '55, six murders took place near Evansville, Indiana; and in April of 1955 Leslie Irvin was arrested on charges of burglary and bad check writing. Soon after his arrest, however, the police got from him a confession to the murders, and they issued this information to the public in a press release. Calling him "Mad Dog" Irvin, the news media unleashed a torrent of publicity about the case. Irvin's previous criminal record was published, and he was described as a "confessed slayer of six."<sup>13</sup>

Irvin's attorney requested a change of venue, and his request was granted -- the trial was simply moved to the county next door.



When *voir dire* proceedings began, 370 of 430 prospective jurors said they believed Irvin was guilty. <sup>14</sup> Irvin, as one might guess, was convicted, but he appealed his case all the way to the Supreme Court. The high court overturned the conviction, thus marking the first time that pretrial publicity was determined to have prevented a fair trial from being obtained. <sup>15</sup>

The 1963 case *Rideau v. Louisiana* was the next step in laying the legal foundation of prejudicial publicity. This time, television was the culprit, but the principles were the same. Wilbert Rideau was arrested shortly after a bank was robbed, and while being held in jail he was interviewed on camera by the sheriff. The interview, during which Rideau confessed to the crime, was given to a local television station which ran it several times.

Because many people in the area saw the telecast, the attorneys, as in *Irvin*, requested a change of venue. The request, however, was denied, and Rideau was convicted. Appealing his case to the Supreme Court, he was able to have his conviction overturned on grounds of unfair pretrial publicity. The Court ruled that "prejudice generated in this way (by televising the "interview") by an official is so conclusive that change of venue and continuance of trial are automatic. No amount of care in jury selection could cure the prejudice." <sup>16</sup>

The third major case in the free press/ fair trial debate is probably most important. In 1953, Marilyn Sheppard, the pregnant wife of Dr. Sam Sheppard, was found bludgeoned to death in her home in Cleveland, Ohio. Police immediately suspected Dr. Sheppard, especially after a somewhat inconsistent story of a "bushy-haired"

intruder who knocked Sheppard unconscious twice and managed to kill Mrs. Sheppard without waking their son. The press, and the Cleveland newspapers in particular, ran a series of sensational articles on the case. Although no clear motive could be found, the stories linked the murder to a suspicion that Sheppard had had numerous extramarital affairs.

Sheppard was convicted and given a life sentence. His appeal, however, went to the Supreme Court, which ruled his trial was a "carnival" and said a large quantity of material was never presented on the witness stand.<sup>17</sup> Justice Tom C. Clark also decided in his majority opinion that "the presence of the press at judicial proceedings must be limited when it is apparent that the accused might otherwise be prejudiced or disadvantaged."<sup>18</sup> The Court's decision in this case paved the way for a new trial, and Sheppard was acquitted.

One other case needs to be mentioned in the context of pretrial publicity. *Estes v. Texas* showed the glaring need for some control over media in the courtroom, because during the trial photographers, cameramen and reporters roamed about freely causing a general disturbance. Some legal minds saw this case as a prohibition of all cameras in the courtroom. However, the 1981 case *Chandler v. Florida* has reopened the door somewhat to the televising of trials.

Several other issues are also important to the free press/ fair trial debate. They include the issuing of special restraining orders on the press ("gag orders"), the use of contempt of court rulings to enforce these orders, and the closing of courtrooms to the public.

Each will be discussed in turn, with a brief summary of the relevant case law.

One of the most dubious "safeguards" for a fair trial that has been used is the so-called "gag order." During the late 1960s and early 1970s, judges increasingly began issuing restrictive orders preventing the news media from releasing to the public information considered "extrajudicial." Often, the only information considered publishable was the most basic facts of the case such as the person's name, the circumstances of the arrest, the charge against him, etc. As might be expected, this trend was met with alarm from journalists, who called it a form of prior restraint. <sup>19</sup>

Several cases are important here. *U.S. v. Dickinson* first found a judge's gag order unconstitutional, but the reporters involved were nevertheless required to pay the fines they had been assessed. However, in the case of *Nebraska Press Association v. Stuart*, the press won a big victory. The Supreme Court ruled that because of the *Near* proscription against prior restraint, gag orders were presumed to have a heavy weight against them as to their constitutionality. In 1984, however, the pendulum swung the other way somewhat as the Court upheld a gag order in *Seattle Times v. Rhinehart*.

A second issue, one quite related, is that of the court's contempt power. A judge has the power to rule a person (without any sort of trial) in contempt if he violates a court order such as a "gag order." <sup>20</sup> This sort of contempt should be differentiated from another form of contempt not discussed here, that of a journalist's refusal to testify or to reveal sources. The contempt resulting from

disobedience of an order may be civil or criminal, and in the case of journalist's violation of a gag order in a criminal trial, the offense would be a criminal one. A jail term would normally last for the time the court is in session.

A third issue concerns the closing of the courtroom to the news media. Obviously, this solution is repugnant to most members of the press. One author states that "closure of the criminal courtroom is a drastic remedy even in the face of the accused's clear right under the Sixth Amendment to a fair and public trial. Closure flies squarely in the face of the democratic precepts under the First Amendment..."<sup>21</sup> While most people might agree that a courtroom should not be closed, there is more debate over the idea of closing pretrial hearings that are not part of the actual trial.

Two cases are of prime importance here. First, *Gannett v. DePasquale* determined in 1979 that the press has no right to attend pretrial hearings. The case outraged journalists, who felt that since many decisions are made in such hearings, the public has a right to know about them. Subsequent cases have largely overturned this ruling. A second important case was the 1980 decision in *Richmond Newspapers v. Virginia*. It was ruled by the Supreme Court that, while the press may not always have the right to cover pretrial hearings, they do have a constitutional right to cover the trials themselves.<sup>22</sup>

One can therefore see how various cases over the past four decades have shaped the law of the free press/ fair trial debate. The journalist has won victories in some places and suffered setbacks in others. Pretrial publicity has been determined to be a definite cause

at times for unfair trials. Gag orders and contempt rulings have been used to curb the media, although this is much less true today.

Courtrooms are open to reporters, but pretrial hearings may still be questionable. These methods of trying to balance free press and fair trial considerations fall into the realm of law. But, the issue must also be addressed from the ethical standpoint.

There is no real agreement among journalists and lawyers about what is ethically required of each. Of course, both realize they must do nothing to jeopardize the fairness of the trial or significantly compromise the freedom of the press. However, these are abstract goals, and the question remains of how these ideas are played out in concrete terms.

In the legal community, the so-called Reardon report, adopted in 1968 by the American Bar Association, is of major importance. Soon after it, a report that came to be called the Kaufman report was published in response to *Sheppard* by the Committee on the Operation of the Jury System, part of the Judicial Conference of the United States.<sup>23</sup> The two reports are in places identical; but, unlike the Kaufman report, the Reardon report had some extra provisions that warrant study. First, however, will come a brief summary of the areas where the reports are in agreement.

Concerning attorneys, the Reardon report concluded, "It is the duty of the lawyer not to release or authorize the release of information or opinion ... in connection with pending or imminent criminal litigation ... if there is a reasonable likelihood that such dissemination will interfere with a fair trial." <sup>24</sup> Basically, the attorney is being told it is his ethical obligation to reveal absolutely

nothing to the media that might jeopardize the trial. This conclusion was reached also for courthouse personnel involved in a potentially unfair trial.

However, whereas the Kaufman report states, "The Committee does not presently recommend any direct curb or restraint on publication by the press of potentially prejudicial material," <sup>25</sup> the Reardon report is not so kind. One of the things it recommends is for courts to adopt a rule giving the defendant the right to make a motion excluding the public, including members of the press, from any pretrial hearing in a criminal case. As has been noted above, this right was upheld in the case of *Gannett v. DePasquale*, but subsequent cases have weakened this provision.

Another scary recommendation in the Reardon report is for quite extensive use of the court's contempt power. Although the report calls for "considerable caution," it also says the contempt power should definitely be used in certain circumstances. <sup>26</sup> These circumstances include a reporter's release of any "extrajudicial statement" beyond what is in the public record or his violation of a "gag order" imposed by the judge. The Reardon report, then, is willing to lay down some strict ethical guidelines to ensure a fair trial, and will back up any violations of these ethics with punishment.

Press-Bench-Bar organizations have also tried to put forth some ethical guidelines concerning the free press/ fair trial dilemma. Many states have such organizations, and different ones have often suggested different ideas. This paper will examine one in particular, from the state of Washington, as a representative example.



The Washington statement reaffirms some important principles that undergird its proposals.<sup>27</sup> First, it says the news media have not only the right but the responsibility to report what goes on in the courtroom; likewise, the parties to a trial have the right to an impartial jury. An important principle, the report states, is that "all news media should strive for objectivity and accuracy," and reporters must recognize the "responsibility of the judge to preserve order in the court and to seek the ends of justice." Editors have the final say in handling the news, but should recall that a person is innocent until proven guilty, that readers are potential jurors, and that no person's reputation should be needlessly injured.

The Washington statement also provides some specific guidelines for courtroom reporting. Certain types of information, such as confessions, prior convictions or witness opinions, are particularly prone to causing prejudice, and the reporter or editor must weigh this when making a news decision. (However, unlike the Reardon report, here there is no threat of contempt hanging over the journalist's head!) The statement further says journalists should be allowed to photograph the defendant outside the courthouse, and are free to report on the proceedings of the trial. Sensationalism should be avoided at all costs, and of course, it is improper to try and influence the outcome of the case.

When attempting to reach an ethical decision in a situation as complicated as this one, it may help to follow the particular ethical framework that seems to best address the issue. The study of ethics has a long history, and many different systems have been proposed. This paper will examine four.

Under moral relativism, right or wrong will depend on circumstances. <sup>28</sup> In the "individual form," all moral judgements must be made based on personal inclination. However, this system cannot provide a rule for behavior that is universally applicable. It would seem the journalist cannot look to this framework in making ethical decisions.

The system of natural law is similar in that it is also lacking in universal application. Of course, this is not supposed to be the case; "natural law" by definition is a rule or guideline that will always be true. However, since natural law principles are not derived from anything other than "what is natural," there is little agreement among people as to what is naturally true.

Under a framework of utilitarianism, concrete decisions can be made by choosing that which furthers human welfare the most. Pleasure is to be maximized in society. <sup>29</sup> However, one must ask if it was perhaps this principle that guided the papers of the yellow journalism era in their efforts to titillate their audiences. The recent rash of sensationalized sex crimes trials must also make one skeptical. Perhaps maximizing the reader's pleasure is not the best course, for this may preclude responsible journalism.

A fourth system has dominated the history of Western society and may be most helpful in making ethical decisions. A religious ethic that values one's fellow man, as is particularly seen in the Judeo-Christian tradition, may be a good one to follow. This ethic declares, in the words of Jesus, "You must love your neighbor as yourself." One writer correctly notes that "this was expressed in a

concern for social justice." 35 The religious ethic puts higher value on the worth of the individual than on society as a body.

The journalist should keep such an ethic in mind when doing courtroom reporting. He does indeed have a responsibility to report the news to society. However, when there is a clear and direct mutual exclusiveness between reporting something and injuring the fair trial, achieving justice for the individual is a higher value. In almost every way, the journalist should intrepidly report on the ills of society to the public. However, when this will damage an individual's right to justice, the reporter should defer to the individual. Censorship and gag orders are not the key. The only answer can come from an ethically-minded journalist.

This paper has tried to demonstrate the complexity of the free press/ fair trial debate. It has also sought to show the importance of both the legal and the ethical aspects of the issue. There are certain legal limits that bind the reporter, and he must try to live within them. However, it is perhaps in the realm of responsible ethics that the most advances can be made in solving this historically intricate confrontation between the First and Sixth amendments.

## End Notes

<sup>1</sup>The Associated Press Managing Editors Association, APME Red Book (New York: The Associated Press, 1965), p.121.

<sup>2</sup>Julian Adams, Freedom and Ethics in the Press (New York: Richards Rosen Press, 1983), p. 65.

<sup>3</sup>J. Edward Gerald, News of Crime: Courts and Press in Conflict (Westport, Conn: Greenwood Press, 1983), p. 5.

<sup>4</sup>Stuart S. Nagel and Marian G. Neef, Legal Policy Analysis (Lexington, Mass: D.C. Heath, 1977), p. 284.

<sup>5</sup>ABA Standards, Fair Trial and Free Press, preamble (1968).

<sup>6</sup>Donald M. Gillmor, Free Press and Fair Trial (Washington, D.C.: Public Affairs Press, 1966), p. 86.

<sup>7</sup>Adams, Freedom and Ethics, p. 33-34.

<sup>8</sup>Gillmor, Free Press, p. 87.

<sup>9</sup>Gerald, News of Crime, p. 46.

<sup>10</sup>ABA Standards, Fair Trial and Free Press, preamble (1968).

<sup>11</sup>APME Red Book, 1965, p. 130.

<sup>12</sup>J. Edward Gerald, "Prejudicial Publicity," Guide to American Law, 8th ed., VIII, 257-258.

<sup>13</sup>Gillmor, Free Press, p. 11.

<sup>14</sup>Ibid, p. 9.

<sup>15</sup>Harold L. Nelson, Dwight L. Teeter and Don R. Le Duc, Law of Mass Communications (Westbury, N.Y.: The Foundation Press, 1989), p. 473.

16Gerald, News of Crime, p. 68.

17 "Sam Sheppard," Guide to American Law, 1984, VIII, 246.

18Ibid.

19APME Red Book, 1974, p. 49-50.

20"Contempt," Guide to American Law, 1984, III, 237.

21Warren Freedman, Press and Media Access to the Criminal Courtroom (New York: Quorum Books, 1988), p. 31.

22Nelson, et. al., Law of Mass Communications, p. 517.

23U.S. v. Dickinson, 465 F.2d 496 (5th cir. 1972).

24ABA Standards, Fair Trial and Free Press, sec. 1.1 (1968).

25Report of the Committee on the Operation of the Jury System on the "Free Press-Fair Trial" Issue 45 F.R.D. 391, p. 401.

26ABA Standards, Fair Trial and Free Press, sec. 4.1 (1968).

27Fred S. Siebert, Walter Wilcox and George Hough III, Free Press and Fair Trial (Athens, Ga.: University of Georgia Press, 1970), p. 125-126.

28Robert N. Van Wyk, Introduction to Ethics (New York: St. Martin's Press, 1990), p. 15.

29Ibid, p. 100.

30Ibid, p. 35.



## Bibliography

Adams, Julian. Freedom and Ethics in the Press. New York: Richard Rosen Press, 1983.

American Bar Association. Standards Relating to the Administration of Criminal Justice. Compilation, 1974.

Associated Press. APME Red Book. New York: The Associated Press, 1965.

Associated Press. APME Red Book. New York: The Associated Press, 1974.

"Contempt." Guide to American Law. 1984. Vol. III.

Freedman, Warren. Press and Media Access to the Criminal Courtroom. New York: Quorum Books, 1988.

Gerald, J. Edward. News of Crime: Courts and Press in Conflict. Westport, Conn: Greenwood Press, 1983.

Gerald, J. Edward. "Prejudicial Publicity." Guide to American Law. 8th ed. Vol. VIII.

Gillmor, Donald M. Free Press and Fair Trial. Washington, D.C.: Public Affairs Press, 1966.

Judicial Conference of the United States (Committee on the Operation of the Jury System) Report on the "Free Press - Fair Trial" Issue. 45 F.R.D. 391, 1968.

Nagel, Stuart S. and Neef, Marian G. Legal Policy Analysis. Lexington, Mass: D.C. Heath, 1977.

Nelson, Harold R.; Teeter, Dwight L.; and Le Duc, Don R. Law of Mass Communications: Freedom and Control of Print and Broadcast Media. Westbury, N.Y.: Foundation Press, 1989.

"Sam Sheppard." Guide to American Law. 1984. Vol. IX.

Siebert, Fred S.; Wilcox, Walter; and Hough, George. Free Press and Fair Trial: Some Dimensions of the Problem. Athens, Ga.: University of Georgia Press, 1970.

U.S. v. Dickinson, 465 F.2d 496 (5th cir. 1972).

Van Wyk, Robert N. Introduction to Ethics. New York: St. Martin's Press, 1990.