



University of Tennessee, Knoxville Trace: Tennessee Research and Creative Exchange

University of Tennessee Honors Thesis Projects

University of Tennessee Honors Program

Spring 5-2009

Neural catheter and cell suspension project

Jennifer Ashley Watson
University of Tennessee - Knoxville

Follow this and additional works at: https://trace.tennessee.edu/utk_chanhonoproj

Recommended Citation

Watson, Jennifer Ashley, "Neural catheter and cell suspension project" (2009). *University of Tennessee Honors Thesis Projects*.
https://trace.tennessee.edu/utk_chanhonoproj/1333

This is brought to you for free and open access by the University of Tennessee Honors Program at Trace: Tennessee Research and Creative Exchange. It has been accepted for inclusion in University of Tennessee Honors Thesis Projects by an authorized administrator of Trace: Tennessee Research and Creative Exchange. For more information, please contact trace@utk.edu.

Neural Catheter and Cell Suspension Project

Jennifer Watson, Kaan Serpersu, Erik Bowman, Brad Meccia

Biomedical Engineering 455/469 – Senior Design

ORNL and Project Mentor: Dr. Boyd Evans, III

Project Advisor: Dr. Jack Wasserman

May 1, 2009

Abstract

Parkinson's disease is a neurodegenerative disorder that impairs motor and speech skills due to the degeneration of dopamine-producing cells located in the substantia nigra portion of the brain. Currently, a novel treatment involves replacing the lost cells with cultivated stem cells that are capable of producing dopamine. Previous studies involving this treatment have complications due to the death of the majority of the injected progenitor cells. It is currently unknown if cell death occurs during delivery or after injection. A neural catheter has been designed that is capable of taking cytometric fluorescence-based measurements using a fiber optic probe. This device will allow researchers to quantify the number of viable cells delivered.

In this study, the original prototype was redesigned in order to be suited for animal testing. A significant reduction of the original cost resulted from fabrication of the new design. A static fixture was built and tested using fluorescent microspheres that used the same optic fiber layout as the catheter to ensure the integrity of the measurements.

In order to deliver a uniform distribution of cells, cell suspension materials are required. Several suspension materials were tested to determine which would provide the most uniform distribution of cells in the medium. The 3RT rat gliomal cell line was used as a model for neural cell delivery. A well-plate experiment was designed to determine which cell suspension materials supported cell viability. A separate cuvette experiment determined the extent of cell settling issues upon delivery. Both experiments tested two different coating mechanisms; comparing the efficiency of Bovine Serum Albumin and PolyHEMA coatings in preventing cell coagulation upon the walls.

Table of Contents

Neural Catheter and Cell Suspension Project

1. Title Page
2. Abstract
3. Table of Contents
4. Introduction
5. Problem Statement
 - a. Fall Timeline
 - b. Spring Timeline
6. Previous Work
7. Catheter Design
 - a. Design
 - b. Materials
 - c. Cost Analysis
8. Fabrication of Static Fixture and Catheter
 - a. Static Fixture
 - b. Catheter
9. Calibration – Static Experiment
 - a. Methods
 - b. Results
 - c. Discussion
10. Cell suspension – Initial choices
11. Cell suspension – Well Plate Experiments

a. Methods

b. Results

c. Discussion

12. Cell suspension - Cuvette Experiments

a. Methods

b. Results

c. Discussion

13. Summary/ Conclusion

14. Budget

15. Acknowledgements

16. References

17. Appendix

18. Standards

4. Introduction

Parkinson's disease is a neurodegenerative disorder which afflicts more than 1 million Americans at a cost of \$25 billion dollars annually [1]. This chronic and progressive disease is caused by the degeneration of dopamine producing neurons in the substantia nigra, which reduces the production of the neurotransmitter dopamine and the number of connections between nerve cells [2]. Dopamine is essential for the transmission of nerve impulses to muscles. The degeneration of these neurons reduces the ability of the basal ganglia to smooth out muscle movements, causing the classic symptoms of Parkinson's disease: muscle rigidity, a resting tremor, slowness of voluntary movements, and a gradual decline of motor skills [2].

The treatment of this disorder is complicated, due to the fact that dopamine is unable to cross the brain blood barrier. An option that has emerged in recent years is stem cell therapy. Dopamine-producing stem cells can be injected into the substantia nigra to supplement production of dopamine by the deficient neurons. However, the prospects of stem cell therapy in the treatment of Parkinson's disease are debated. Past studies have showed that the up to 90 % of the injected cells undergo apoptosis [3-6]. It is currently unknown if the cell death is due to complications from the injection process or as a result of an immune reaction. In order to determine the viability of the cells upon insertion, a cytometric neural catheter has been designed [7]. This device will allow researchers to quantify the number of viable cells delivered.

5. Problem Statement

The original prototype of the neural catheter had key issues that needed to be addressed by the team, the most significant of which was that it was not biocompatible due to material selection. In order to enable the device to be used for future animal testing, the catheter needed to be redesigned to incorporate biocompatible materials. The original design cost \$1600.00 for the fabrication of two prototypes. An additional goal was to be able to fabricate 4-6 prototypes under a \$1600.00 budget. This required a significant reduction in price per prototype, so the design needed to be rugged but elegant enough that available machine shops would be able to fabricate the catheter under budget and to needed specification.

The cytometric neural catheter uses fiber optic elements incorporated into the tip to quantify the cells and determine viability upon delivery. Past experimentation of the prototype proved to have cell settling issues which caused nonuniform delivery, possibly resulting in cell death. The choice of cell suspension material, which lacked the ability to consistently suspend the cells over time, was theorized to be the root of the settling problem. One separate project goal was to research and choose a cell suspension material which would allow a uniform delivery. This required significant testing of different materials to check for cell viability and cell settling. Experiments that tested these issues needed to be designed and executed by the team using the researched potential suspension materials.

This paper discusses the design and calibration of the redesigned catheter. The methodology and results for determining the most efficient suspension material is also presented. Several cell suspension materials were tested in order to determine which best

serves the interests of cell delivery. The two factors that were considered were the ability of the material to support the cells physiologically and to provide uniform delivery.

A. Fall Timeline

Table 1 represents the time allocation for the different aspects of the fall project.

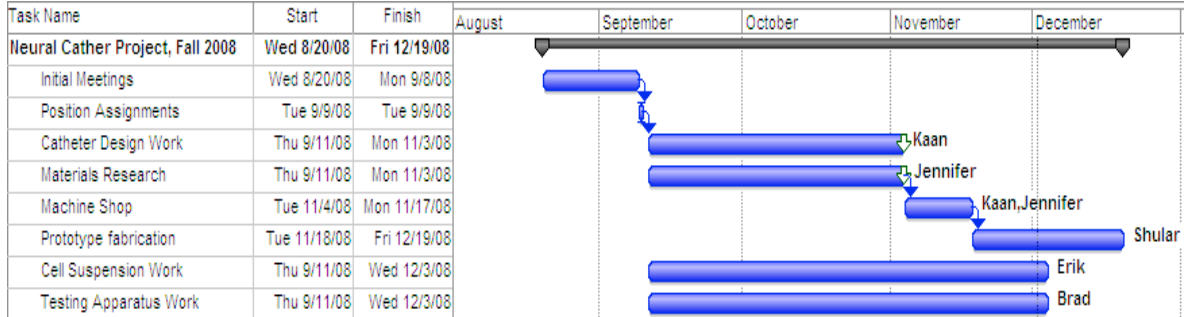

Table 1: Gantt Chart for Fall 2008

B. Spring Timeline

Table 2 represents the time allocation for the different aspects of the spring project.

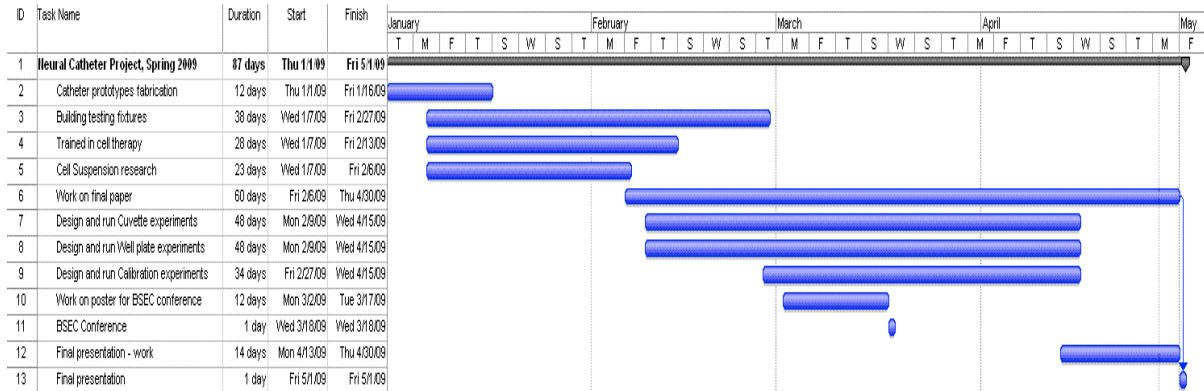

Table 2: Gantt Chart for Spring 2009

6. Previous Work

The original catheter prototype was a modular tip designed to be compatible with existing neurosurgical catheters. The tip incorporates optical fibers for the cytometric determination of the number of viable cells exiting the port of the tip. The prototype was

fabricated out of common brass and has an outer diameter of 3.2 mm and the exit port is 0.38 mm in diameter. The total length of the catheter tip was 12.8 mm. The tip had the optical fiber mount as well as a thin-walled extension. The extension served to attach a multi-lumen tube to the tip which had two cuts in it. One of the cuts would protect the optical fibers upon insertion and delivery and the other would serve to connect to the mount. The schematic of the multi-lumen tube is shown in Appendix 2. The delivery tube would be inserted inside of the multi-lumen tube. The original pocket for the porthole was cut with a mill saw. A rendered image of the original base is shown in Figure 1. The schematic of the original prototype is in the Appendix 3 [7].



Figure 1: Rendered Image of the Original Base

The tip has a series of smooth grooves, designed to assist in the placement of the optical fibers. These grooves allow the self-alignment of five optical fibers. Two fibers were polished at a 45° angle and were coated with a 100 nanometer layer of chromium using electron beam evaporation in order to create a reflective surface. The fibers were spaced 0.25 mm apart and attached using an ultraviolet light curing epoxy [7]. The setup of the optical fibers is shown in Figure 2.

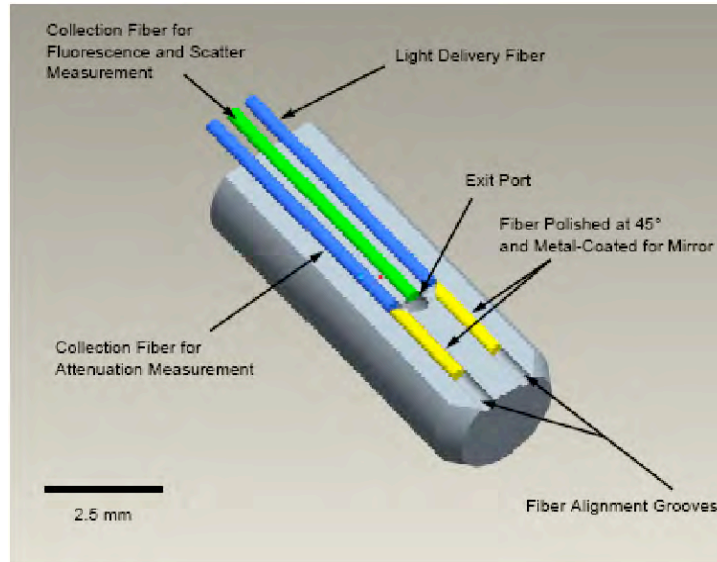

Figure 2: Set-up of Fiber Optic Assembly

As shown in Figure 2, the blue fibers act as the light delivery and collection fibers. The two 45° polished fibers act as turning mirrors, allowing the excitation beam to enter the system by the delivery fiber and exit via the collection fiber. The alignment grooves allow the illumination delivery and the turning fibers to work together so that the excitation beam, designed for fluorescence illumination, can be delivered across the exit port. The green fiber, as shown in Figure 2, serves to measure the scatter of the excitation beam and the fluorescence within the cell suspension [7].

The original experimentation used the RT2 rat gliomal cell line as a neural cell delivery model. The delivery suspension material was Phosphate Buffer Saline (PBS). These cells were transfected to express green fluorescent protein (GFP) and are designated as 3RT1 cells [8]. As the cells die the expression of GFP halts or dramatically decreases [7]. The catheter tip delivers an excitation beam designed to fluoresce GFP. The optical fiber set-up measures the fluorescence of the delivery, allowing the

quantification of cell death due to GFP expression. Dr. Boyd Evans, III of Oak Ridge National Laboratory has applied for a patent for this device.

7. Catheter Design

One of the original goals of the project was to design and fabricate a rugged version of the neural catheter tip that could be used in animal testing. In order to accomplish this goal, our team had many issues to address. There were physical and material requirements that needed to be taken into consideration in the design process. The design also needed to allow the fabrication of 4-6 prototypes under a \$1600.00 budget, so a significant reduction in cost was required. Design modifications were made in order to reduce the complication of the original design and lower the fabrication cost.

A. Design

The physical requirements of the design required precisely cut v-edges, all cut to the same depth and angle, which would house six optical fibers. These v-edges needed to be the same height as the optic fibers in order to create a flush surface. A port hole would be cut at the top of the catheter tip and needed to line up precisely with the middle v-edge to ensure accurate cytometric measurements. This port hole also had to reach the inlet hole for delivery. The optical fibers would need to be protected during insertion and delivery, so the new design had to encompass this as well. The maximum size allowed for the design was a 1/8" diameter with a 1/2" length, to be allowed for future animal testing. The assembly of the testing apparatus needed to be taken into account, so the design was modified to ensure ease of assembly.

Several initial designs were proposed and drafted (Appendix 1), but many of them did not solve all the initial requirements. Eventually, it was decided that the elimination of the extension and the multi-lumen tube would significantly reduce the cost of fabrication and also ease the assembly of the full testing apparatus. The thin-wall extension on the previous design was a difficult and costly cut. This extension served to attach the expensive multi-lumen tube, which would protect the fibers. The use of the multi-lumen tube enhanced the complication of the design, due to the fact the tip had to be designed with intense restrictions so that the multi-lumen tube would attach to the catheter tip (Appendix 2). It was decided that a bridge material could serve as an extension, which would allow the attachment of the delivery tubing. A cheap and biocompatible heat-shrink tube would surround the tip and the optical fibers in order to serve as protection against the natural environment. This significantly reduced the fabrication cost and also reduced the size of the assembly. The schematic of the redesigned catheter tip is shown in Figure 2. The full-rendered image of the redesigned tip is shown in Figure 3.

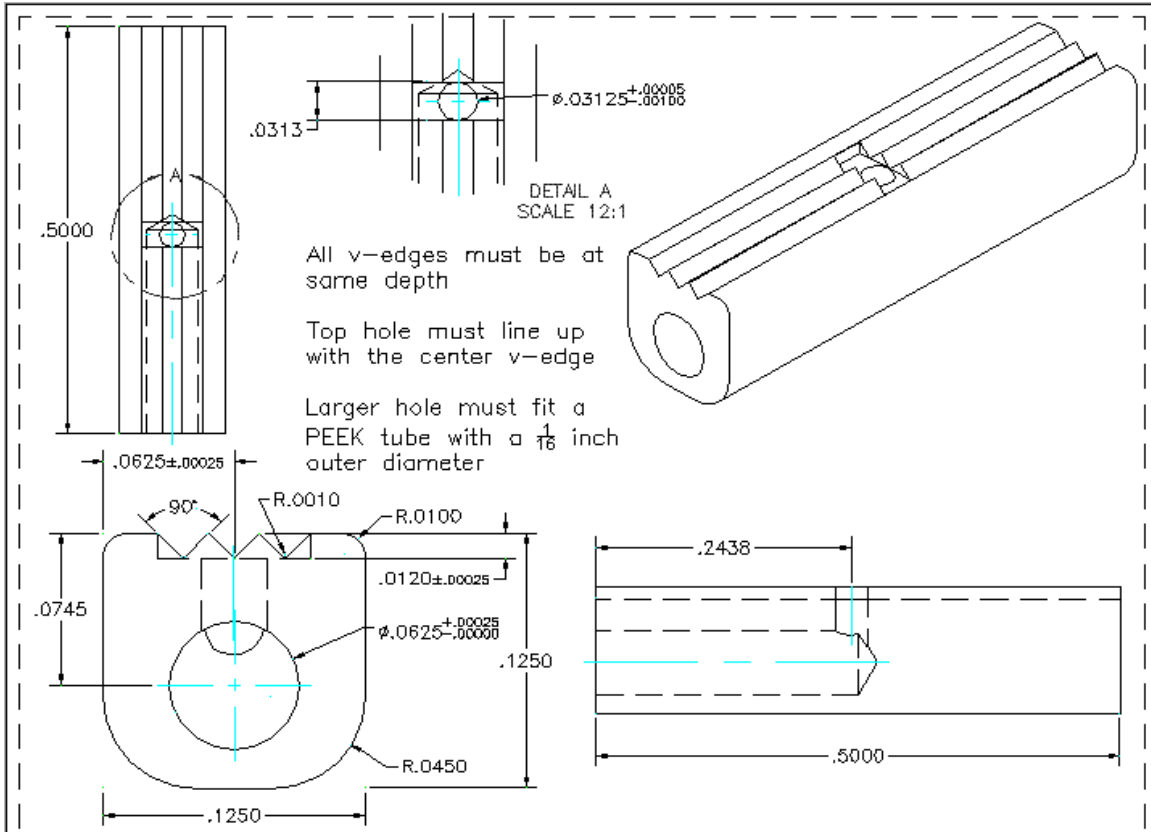

Figure 2: Final Design of Catheter Tip



Figure 3 – Full Body Render of Assembly Base

The v-edges that run along the catheter tip were designed to be the same height as the optic fibers and needed to be straight cuts. To ensure the cuts were the same height and depth, the machine shop that fabricated the catheters needed to have a mill saw. As shown in Figure 2, the v-edges were given slight fillet cuts to smooth out the shape cut. This would allow the fibers to sink into the v-edge, ensuring they did not extend above the catheter.

The inlet hole on the catheter for the bridge tube connection was designed to have a 1/16" diameter. This connection between the catheter tip and the bridge connector was designed to be push-fit so that an adhesive between the bridge tube connection and the catheter would not be required. This push-fit design was done to lower the difficulty when building the full assembly. Another benefit to using a 1/16" diameter between the inlet hole and bridge connection was that stock items could be readily purchased instead of the need for custom tubing. The schematic of the bridge tubing is shown in Appendix 4. The inlet hole was offset from the v-edges equal to the diameter of the fibers to allow ease of assembly and to avoid a potential bending of the fibers. A separate supply tube that would connect to the other end of the bridge tubing was also designed to be push-fit. Luer locks were purchased to allow attachment of the supply tube to the syringe pump. The bottom of the catheter tip was given a flat edge in order to increase stability while attaching the optic fibers to the v-edges.

The porthole was designed to sit in a pocket that would be cut into the top of the catheter. The pocket was cut to the same depth as the v-edges and would ensure that all the cells would be counted as they passed through the tip and exited out the porthole. As shown in Figure 2, the porthole was designed to be cut as far back as possible into the

bevel of the inlet cut. This would serve to prevent the cells from coagulating at the end of the inlet hole. These design modifications were done to help ensure accurate counting of cells.

Tolerances were important for this device. It was important that the v-edges were of near exact same depth and width to ensure the laser light would travel in the correct path. Due to the small scale of the device, tolerances were designed to be as small as possible. A render of the full catheter assembly, including catheter tip, bridge connection tube, supply tube, and fiber optics, can be seen in Figure 4.

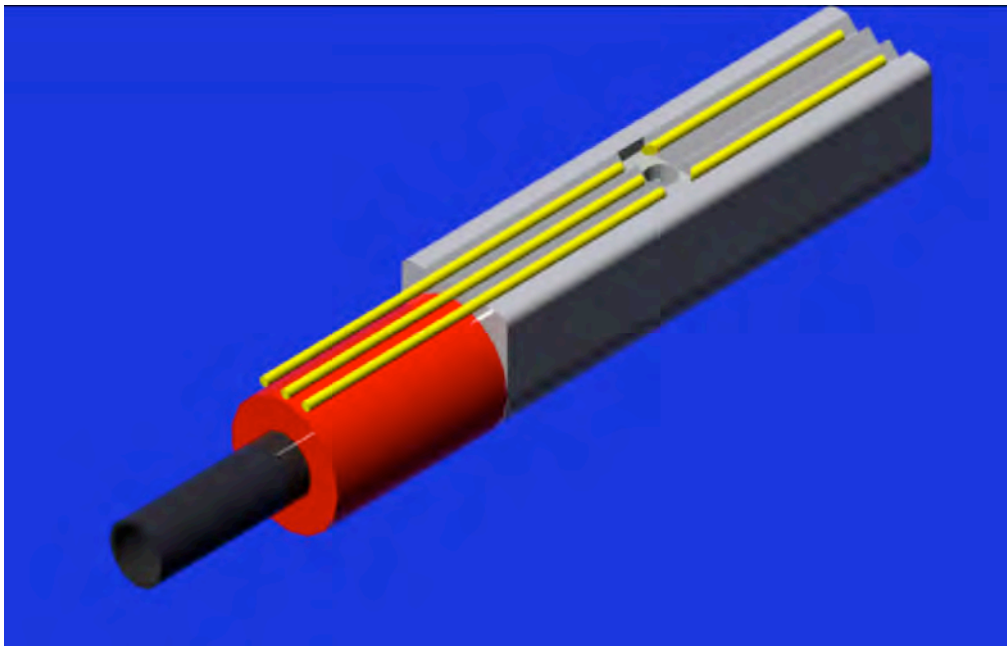

Figure 4 – Full Assembly Render: Titanium Catheter, PEEK Bridge Connector Tubing (black), PVC Supply Tube (Red), Fiber Optics (yellow)

B. Material Selection

Material selection was an important aspect of the design. There were many requirements that the selected material had to meet, among these were: inherent biocompatibility, MRI compatibility, machinability, and ease of sterilization. Through

much research, it was decided that titanium would prove to be the best base material for the catheter tip.

The most important requirement is that the material was inherently biocompatible. Stem cell treatment was estimated to last between two hours and two weeks [7], so it was important to select a material which could remain *in vivo* for that amount of time without causing negative side effects. Titanium has been shown to be able to remain *in vivo* for up to 26 weeks without causing behavioral changes or neurological deficits [9]. It is also important to note that titanium does not require surface treatment for biocompatibility, so this choice also reduced costs.

Magnetic resonance imaging (MRI) compatibility was also important. The placement of the catheter in the correct region of the brain, the substantia nigra, is required for effective treatment. The material must be able to undergo an MRI scan to determine the correct placement of the device. Titanium is a nonferrous metal, so there is not a magnetic attraction in the MRI environment, allowing the metal to undergo an MRI scan [10]. Also, there is not a significant heat increase in titanium during an MRI, so there would not be any damage to local tissues during the scan [11].

Another important thing to note is the creation of artifacts during an MRI. Titanium is MRI compatible due to the fact that it is not ferromagnetic, but it is slightly paramagnetic, causing the image to read a slight artifact on the scan. Through research, it was determined that the artifact would not interfere in the determination of placement of the catheter tip [12, 13].

Titanium was also chosen due to ease of machining. The smooth and precise v-edge tolerances were essential to the design and a material was needed that could be

machined to the design's strict tolerances. The design required a specific tool for machining the v-edges, a mill saw, and would leave a clean, finished surface after the cuts were made. Shular Tools, located in Oak Ridge, Tennessee, had the tools and ability to manufacture the device.

Polyether-ether-ketone (PEEK), a thermoplastic, was chosen as the material for the bridge tubing (Appendix 4). There were several requirements of the bridge tubing that PEEK fulfilled. The material had to be rigid to allow ease of insertion and also had to be inherently biocompatible. It also needed to be manufactured in thin wall tubes to ensure steady flow from the transition of the bridge tubing to the catheter tip. PEEK is mass produced as thin-wall tubing in a stock size that fit our design. This choice of material fit all of the requirements of the bridge tubing and was significantly cheaper than custom tubing or any other alternative.

The delivery tube is a polyvinylchloride (PVC) tube. This tubing was designed to be push-fit as well, easing assembly by fitting to the PEEK connector tube without any need of an adhesive. The heat-shrink tubing was polyolefin. Both of these materials are biocompatible and sold in stock sizes that fit our design. The titanium tip and the optical fibers are able to undergo a low-dose gamma radiation [14, 15]. The polyimide covering of the optical fiber has an aromatic group attached to polymer chain, making it resistant to low-dose radiation [15]. PEEK must undergo Ethylene Oxide (EtO) sterilization [16]. The PVC tubing and polyolefin heat shrink tubing will be disposed of after use.

C. Cost Analysis of Design

The new design simplified the original design and made it more efficient. The tips were manufactured out of titanium while utilizing a PEEK bridge connector to fulfill the application requirements. Six prototypes of the tips were fabricated for only \$408.00. The PEEK tubing cost \$26.50 for 25 feet and fifteen feet of PVC and 6 feet of the heat shrink tubing totaled \$7.50. These items gave a total cost for the design of \$442.00 which was only a fourth of the catheter budget. The design of catheter is both rugged and ready for animal testing and is significantly cheaper than the previous prototype.

8. Fabrication of Static and Catheter Fixtures

Two different testing fixtures were made: static fixtures and catheter assemblies. In order to assemble the fixtures, polished optical fibers were required since a clean signal was a necessity for testing. The fibers were polished at 90° and 45° angles using the Bare Fiber Adapter Kit by Ocean Optics™ and designed hockey-pucks, which are shown in Figure 5.

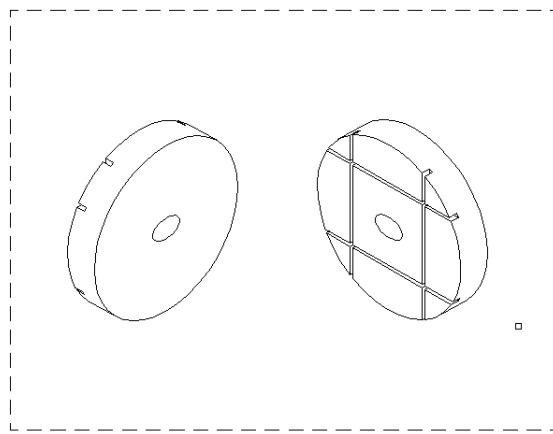

Figure 5: Hockey-puck

Each fiber was polished using three successive sandings: 15 μm , 5 μm , and 1 μm and viewed using the Clauss Fiber Optic Inspection Microscope™ to determine if the fiber was clear. The 45° fibers and the middle fiber were coated with a 100 nanometer layer of chromium using electron beam evaporation in order to create a reflective surface. The 45° fibers were chromed to act as turning mirrors and the middle fiber was chromed to enhance the signal. The light delivery fiber was lined up with the laser in order to pass the light to the fixture to excite the microbeads or 3RT1 cells. The collection fiber was attached to a computer that collected data using the Ocean Optics OOIbase32 program.

A. Static Fixture

The static fixtures were assembled on the back of a Petri dish. The fibers were assembled in accordance to the original catheter fiber optic set-up. The fibers were assembled manually on the Petri dish using a video microscope. The video microscope was also used to confirm the quality of the fibers angles. The fibers were adhered to the Petri dish using a Dura Hold Blocking Compound (Part # KL16050) and cured using an ELC-410 Spot Cure System™.

Due to sensitivity and accuracy required for the alignment of the fibers, the assembly of the static fixtures was time consuming. The alignment of the fibers had to be perfect, along with the appropriate rotation of the 45° fibers. The first static fixture took two weeks to assemble with the last two fixtures taking a week a piece to assemble. A highly magnified image of the static fixture is shown in Figure 6.



Figure 6: Static Fixture Under Video Microscope

B. Catheter Assembly

The two catheter assemblies proved much less time consuming than the static fixtures. The smooth design of the v-edges allowed easy insertion and rotation of the optical fibers, drastically cutting down time of assembly. The catheter set-ups took a day each to assemble. These fibers were also adhered to the fixture using a Dura Hold Blocking Compound (Part # KL16050) and cured using an ELC-410 Spot Cure System™.

9. Calibration Experiment

The static fixture was made in order to test and calibrate the fiber-optic layout of the titanium catheter. Microbeads of increasing concentration would be placed on the static fixture and fluoresced. Ideally, a linear relationship between the fluorescent intensity and fluorescent concentration should be obtained, proving that the optic-fiber set-up is able to successfully measure the concentration of microbeads.

A. Methods

The used microbeads were 10 μm in diameter, approximately the same size as neurons. The beads were originally stored in a solution that contained 0.15M NaCl, .05% Tween 20, and 0.02% thimerosal. In order to simulate the environment the beads were stored in, the experimental solutions that were made contained 99.5 mL of water and 0.5 mL of Triton X 100, which imitated the detergent Tween 20. Before the solutions were made, the beads were vortexed and sonicated to suspend the beads and ensure even distribution. Seven solutions were made with increasing concentration of fluorospheres including a blank solution, 10%, 30%, 50%, 70%, 85%, and 100% microbeads. Each concentration was made in 5 mL volumes with 5 μL placed upon the static test fixture to take readings. The laser was set at 477 nm and powered at 4.8 mW. The experiment was run using green fluorescing microbeads, which fluoresced at 515 nm.

B. Results

Figure 7 is an image of the static fixture during experimentation. The microbeads were placed on the static fixture and fluoresced.



Figure 7: Static Fixture with Green Fluorescing Microbeads

The results of calibration experiments are shown in Figures 8 and 9. Figure 8 is the data obtained from the Ocean Optics OOIbase32 program, showing the intensity curve of each of the concentrations. Figure 9 displays the relationship between the intensity at 537.93 nm and the concentration.

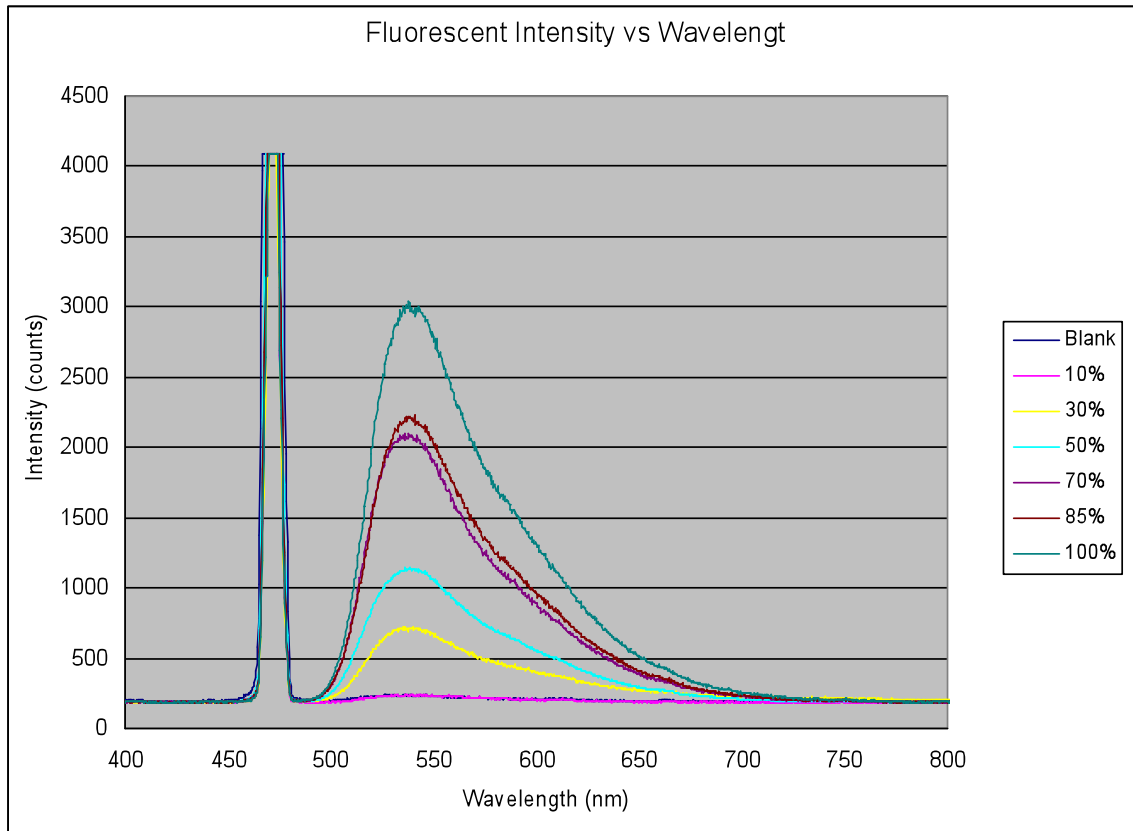

Figure 8: Fluorescent Intensity versus Wavelength

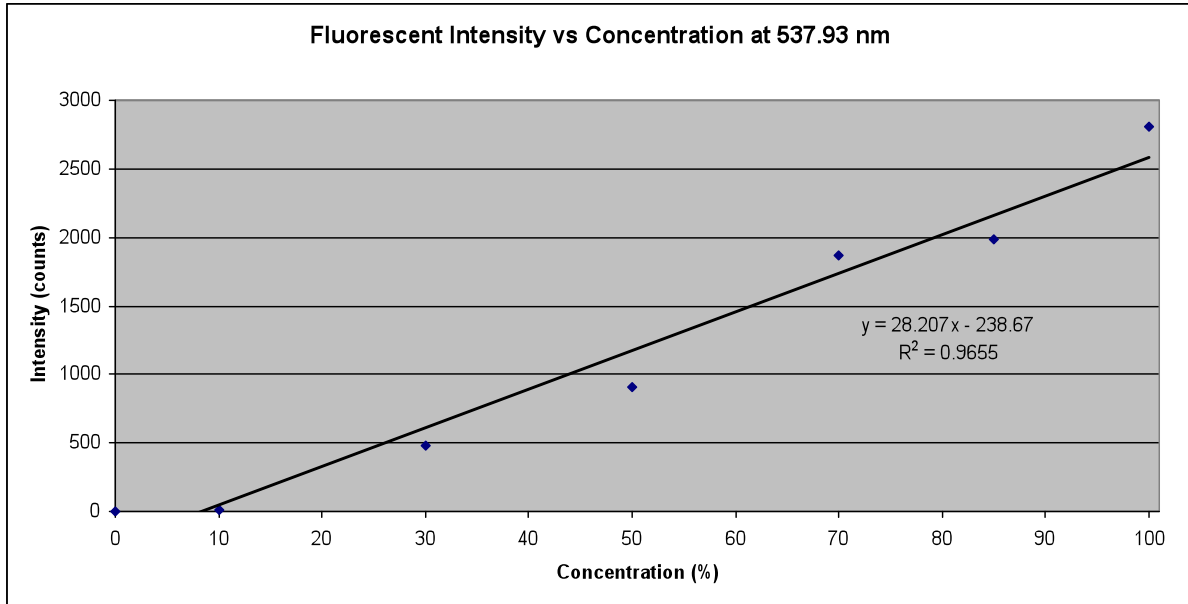

Figure 9: Fluorescent Intensity at 537.93 nm versus Concentration

C. Discussion

Figure 8 shows the fluorescent intensity versus the wavelength. The peak shown at 477 nm is the intensity measured directly from the laser. The highest fluorescence of the green beads is shown at 537.93 nm. It can be seen here that as the concentration increases that the fluorescing intensity does as well.

As hypothesized, a linear relationship was obtained between the fluorescing intensity at the fluorescing wavelength of the microbeads and the concentration (Figure 9). This shows that as the concentration of the microbeads increases, the measured intensity increases as well. Statistical analysis was done to prove linearity; an R^2 value of 0.9655 was obtained. This relationship shows that the fiber optic layout of the titanium catheter can accurately measure fluorescing intensity.

10. Cell Suspension - Reasons

An extensive literature review for suitable media was accomplished in the fall of 2008. From the literature six media were determined to be candidates for testing in the spring of 2009. The six media chosen were phosphate buffer saline (PBS), Dulbecco's modified eagle medium (DMEM) without phenol red, varying concentrations of methyl cellulose, N-isopropyl acrylamide (NIPPAM), NIPPAM-co-Acrylic Acid (NIPPAM-co-AAc), and NIPPAM-co-AAc with fibronectin proteins functionalized to the copolymer for cell adhesion. It was determined that the best media to test were PBS, DMEM, and methyl cellulose on a basis of availability, expense, and ease of processing. The synthesis of the polymeric media was more expensive and difficult to synthesize. Also, a stock pile of polymer would be small and the synthesis of the polymer would take more than a day as compared to the hour it took to make the PBS/methyl cellulose gels.

These original media were first used to determine their efficacy in suspending the cells in the first cuvette experiment. However, from the data received in the first cuvette experiment the cells had died within two hours of the experiment. Because of the cellular death the choices of media were modified as to improve the cell viability for the cuvette experiment and, ultimately, delivering the cells for in vivo studies. Combinations of the three original media—methyl cellulose, PBS, and DMEM—were made to optimize cell viability and suspension. Methyl cellulose acted to increase the density of the suspension material to promote suspension of the cells. DMEM is a cell growth media which promotes proliferation. It contains all of the essential elements for cell life and has a greater density than PBS, but not to a significant degree. The compositions involving DMEM were meant to support cell viability and provide suspension. In addition to these

original media selections artificial cerebrospinal fluid (CSF) was also selected as a possible option.

PBS was the media used in the original design for the cell delivery. The density of the cells was greater than the density of PBS, causing the cells to settle in solution. Since it was noted the cells settled, PBS was the control media for the new media selected. The media used for the cuvette experiments was the following: PBS (control), DMEM only, artificial CSF, 1% methyl cellulose in PBS by weight, 0.5% methyl cellulose in PBS by weight, 1% methyl cellulose in DMEM by weight, 0.5% methyl cellulose in DMEM by weight with the intention to find the media that is best suited for uniform delivery of cells and cell viability.

11. Cell Suspension – Well Plate

A well-plate experiment was designed and executed to determine viability of 3RT1 cells in a variety of suspension materials using different coating methods. After the wells were coated, cells were added to the suspension materials in each well. The well-plate was then viewed under an incubated fluorescent microscope, which excited the 3RT1 cells. This fluorescence allowed the visual determination of cell viability in the given suspension material and coating.

A. Methods

Seven suspensions were tested, including: Phosphate Buffer Saline (PBS), 1% methyl cellulose in PBS, 0.5% methyl cellulose in PBS, DMEM, 1% methyl cellulose in DMEM, 0.5% methyl cellulose in DMEM, and Artificial Cerebrospinal Fluid (CSF). All DMEM culture media used in the experiments were without phenol red. Each of these

solutions was tested with three different coating methods. One section did not have a coating and served as a control. The other two coatings were polyHEMA and bovine serum albumin (BSA). The 3RT1 cells were incubated at 37°C with 5 % carbon dioxide buffer and fed with phenol red fortified DMEM with 10 % fetal bovine serum.

| Suspensions | Columns 1 - 4: No Coating | Columns 5 - 8: PolyHEMA | Columns 9 - 12: BSA |
|-----------------------|---------------------------|-------------------------|---------------------|
| PBS | | | |
| 1% MC-PBS | | | |
| 0.5% MC-PBS | | | |
| 1% MC-DMEM | | | |
| 0.5% MC-DMEM | | | |
| DMEM | | | |
| Artificial CSF | | | |

Figure 10: Well-plate Set-up

In order to coat the wells, approximately 25 μ L of each coating was added to the corresponding well. After 5 minutes, the BSA was aspirated out of the well. Similarly, the polyHEMA was removed after 30 minutes. After the coating process, 100 μ L of each suspension material was added to the wells. The 3RT1 cells were then added to each well in 100 μ L amounts to give a 1:1 ratio between the suspension material and cells. This entire process was performed in a fume hood to prevent contamination.

After the addition of the cells, the well-plate was placed in an incubator for 5 minutes to allow adequate mixing of the cells and suspension material. The well-plate was then viewed under an incubated Nikon Diaphot 300™ fluorescent microscope and images were captured using OpenLab™ software on a laptop.

The experiment was performed three times. The first experiment was executed using the following suspension materials: PBS, 1% methyl cellulose in PBS, 0.5% methyl cellulose in PBS, and 1% methyl cellulose in DMEM and pure DMEM. In this

experiment, only two coating methods were tested: BSA and no coating. PolyHEMA was not included in this experiment due to the fact that it was not available for testing at that time. The second experiment was performed with the same suspension materials, but included a 0.5% methyl cellulose in DMEM solution. PolyHEMA was added as an additional coating method in the second experiment. The third experiment had the same experimental set-up as the second experiment, but added artificial CSF as an additional suspension material. The well-plate set-up is shown in Figure 10. A similar set-up was used for all three experiments.

B. Results

Altogether, 180 images were taken of well-plate data with the best images from each group collected and made into montages shown below. The first experiment results are shown in Figure 11. The images from top to bottom are PBS, 1% methyl cellulose in PBS, 0.5% methyl Cellulose in PBS, 1% methyl cellulose in DMEM and finally pure DMEM. The left column represents the uncoated wells; the right column is the BSA coated wells.

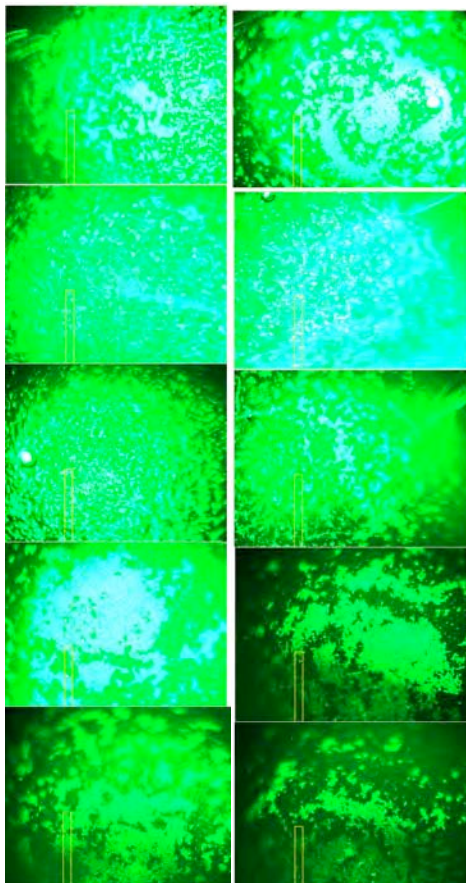

Figure 11: Experiment 1 Results (Column 1 – No Coating, Column 2 – BSA)/(Row A - PBS, Row B - 1% Methyl Cellulose in PBS, Row C - 0.5% Methyl Cellulose in PBS, Row D - 1% Methyl cellulose in DMEM, Row E - 0.5% Methyl Cellulose in DMEM, Row F - pure DMEM)

Figure 12 is the results from well-plate experiment 2. From top to bottom, the suspension materials are PBS, 1% methyl cellulose in PBS, 0.5% methyl cellulose in PBS, 1% methyl cellulose in DMEM, 0.5% methyl cellulose in DMEM, and pure DMEM. The far left column is the untreated wells. The middle column is the polyHEMA coating, while the third column is BSA. In the first column, there is not an image of the 0.5% methyl cellulose in PBS with no coating. All of the cells had died and there was not a good representative image of the well available.

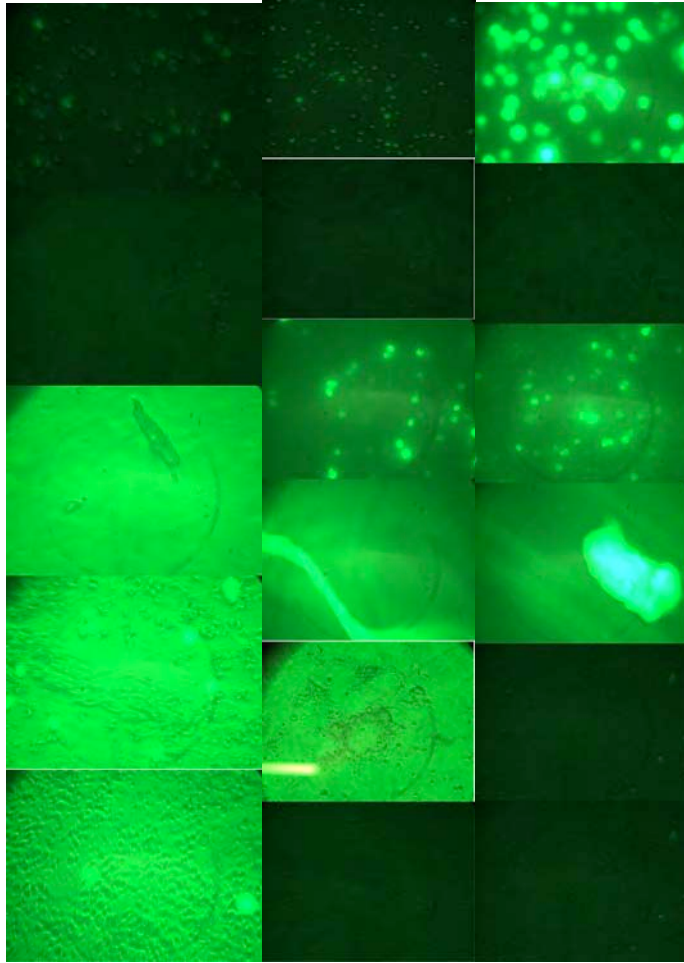

Figure 12: Experiment 2 Results (Column 1 – No Coating, Column 2 – PolyHEMA, Column 3 – BSA)/(Row A - PBS, Row B - 1% Methyl Cellulose in PBS, Row C - 0.5% Methyl Cellulose in PBS, Row D 1% Methyl cellulose in DMEM, Row E - 0.5% Methyl Cellulose in DMEM, Row F - pure DMEM, Row G - artificial CSF)

Figure 13 is the results from well-plate experiment 3. From top to bottom, the suspension materials are PBS, 1% methyl cellulose in PBS, 0.5% Methyl Cellulose in PBS, 1% Methyl cellulose in DMEM, 0.5% Methyl Cellulose in DMEM, pure DMEM, and artificial CSF. The far left column is the untreated well. The middle column is the polyHEMA coating, while the third column is BSA.

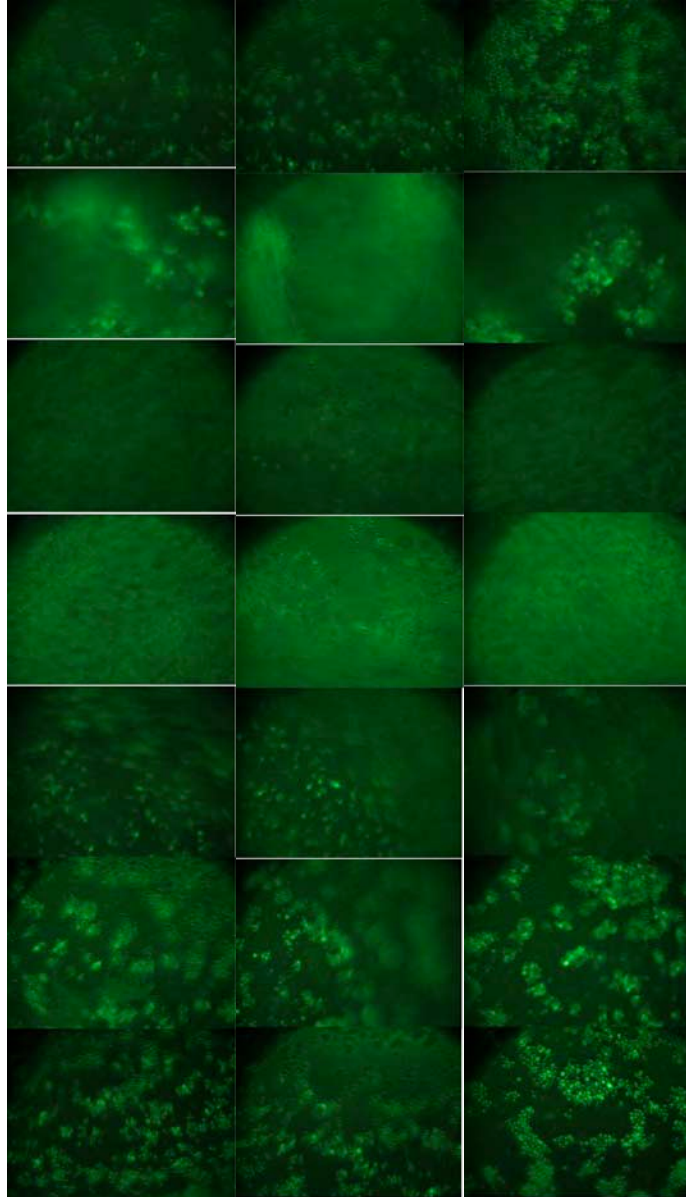

Figure 13: Experiment 3 Results Figure 12: Experiment 2 Results (Column 1 – No Coating, Column 2 – PolyHEMA, Column 3 – BSA)/(Row A - PBS, Row B - 1% Methyl Cellulose in PBS, Row C - 0.5% Methyl Cellulose in PBS, Row D 1% Methyl cellulose in DMEM, Row E - 0.5% Methyl Cellulose in DMEM, Row F - pure DMEM, Row G - artificial CSF)

C. Discussion

The results from the first experiment are shown in Figure 11. This was the first well-plate experiment and the first opportunity to use Nikon Diaphot 300™ to determine cell viability. The results appear to suggest that each of the solutions support cell

viability similarly, but this is believed to be misleading. Due to a time constraint, the pictures were taken quickly and did not allow adequate mixing of suspension material and the cells. Also, due to inexperience with the equipment, there is also a significant background fluorescence, which misleads the viewer into overestimating the cell viability in the suspension material. Considering the results of experiment 3, which show a difference in the cell viability dependant upon the suspension material and coating method, these results are believed to be misleading due to the aforementioned reasons.

The second run of the experiment also resulted in skewed results (Figure 12). During testing, multiple users were utilizing Nikon Diaphot 300™. This led to the incubator being left open during testing and long intervals of time occurred between measurements. Regardless of the skewed results, it was observed that coatings were required for viability. The coatings prevent the cells from clinging to the walls, which causes a reduction in cell viability. This can be seen Figure 12 in the no-coating column. It was difficult to capture a good image with the wells that lacked a coating, due to the fact the cells gripped to the well-wall. Also, cell coagulation was observed in the 1% methyl cellulose in DMEM solution.

By the third experiment, the experimental protocol had been finalized and there was no outside interference. This experiment yielded the best results, due to the fact all of the wells were imaged in one setting. These results are shown in Figure 13. Comparatively, all three coating methods of pure PBS show a limited amount of cell viability. It was also noted that the cells initially settled very quickly. Increasing concentrations of methyl cellulose were added to the PBS solutions. It was hypothesized that higher concentrations of methyl cellulose would reduce cell viability due to

coagulation effects [17]. Experimentally, it was shown that the cells were more viable in the 1% methyl cellulose than the 0.5% methyl cellulose solutions. The 1% methyl cellulose solution shows viable and suspended cells. Suspension can be noted due to the cloud effect in the images. The 0.5% methyl cellulose solutions did not show evidence of cell viability. This is theorized to be due to experimental procedures. The 1% methyl cellulose images were captured before the 0.5% solutions. It is believed that that the 1% solutions were alive due to the fact the images were taken first, but cell death occurred shortly after imaging. Our hypothesis holds true with the increasing concentrations methyl cellulose in DMEM. The 1% methyl cellulose in DMEM solution does not support cell viability. The 0.5% solution keeps the cells viable and also participates in a limited amount of suspension. As the concentration of methyl cellulose increases, cell viability decreases due to the coagulation effect [17]. It is also noted that as the concentration of DMEM increases in these solution, the cell viability also increases. This is due to the nature of DMEM. This suspension was designed to promote cell growth and proliferation, increasing the concentration would provide a more suitable environment for the cells, promoting cell viability.

The pure DMEM solutions had the best cell viability with all coating methods. The solution also shows evidence of suspension. Artificial CSF also showed cell viability, although not as significant as DMEM. The BSA coating of Artificial CSF had a similar viability to the pure DMEM solution. Artificial CSF promoted cell viability, but settled quickly.

Image capture proved more difficult with the wells that were not coated. Coatings tended to reduce the amount of cells clinging to the well-plate walls. Overall, the BSA

coating method appeared to be the best choice. This method tended to do the best job in keeping the cells off of the well-plate walls, easing image capture.

Experimentally, it was determined that cell viability was an issue in the 0.5% methyl cellulose in PBS and 1% methyl cellulose in DMEM solutions in all three sets. Results suggested that BSA coatings produced better imaging. In conclusion, it was determined that the 1% methyl cellulose in PBS, 0.5% methyl cellulose in DMEM, pure DMEM, and Artificial CSF solutions better promoted cell viability.

12. Cell Suspension - Cuvette

A cuvette experiment was designed in order to test for cell settling in each solution. Each cuvette was prepared with either a BSA or PolyHEMA coating, a given concentration of cells, and one of the following suspension materials: PBS, 1% Methyl Cellulose in PBS, 0.5% methyl Cellulose in PBS, and 1% methyl cellulose in DMEM, 0.5% methyl Cellulose in DMEM, pure DMEM, and artificial CSF. Blanks were also made of each suspension material and coating method in order to test for background fluorescence. The cuvettes were placed in CUV – ALL—UV™ four-way cuvette holder to be excited with a 477 nm laser and the intensity was measured over time. The experimental set-up can be seen in Figure 14.

A decrease in the intensity over time shows that the cells are settling within the given suspension material. After all readings had been made, the solution was agitated in order to resuspend the cells, and an additional reading was taken. This allowed the determination of whether the decrease in intensity was due to cell settling or cell death.

A. Methods

The coating method of the cuvette experiment was similar to the well-plate experiment. BSA and PolyHEMA were added to the cuvettes in 1.5 mL volumes. After 5 minutes, the BSA was removed. Similarly, the PolyHEMA was removed after 30 minutes. Fourteen cuvettes of each coating were prepared; 7 of these cuvettes would receive cells, while the other 7 would serve as blanks. The blanks would serve to check for background fluorescence of the suspension material and coating. The cell volume to suspension material ratio was 1:1, each adding 0.75 mL to the final volume of 1.5 mL. This was done in order to ensure that the ratio was the same as the well-plate experiment.

During testing, the CUV – ALL—UV™ holder was placed on a hot plate in an enclosed environment in order provide a suitable environment for the cells. The temperature was monitored throughout experimentation. The cuvette was then excited by a 477 nm laser, causing the 3RT1 cells to fluoresce at 512 nm. In order to prevent photobleaching, the laser was only allowed to hit the cuvette for few seconds at each measurement. This experiment was run three times. The first experiment had inconsistent and unreliable data. Experimental design modifications were made in order to obtain reliable data for the next two experiments. For the second experiment, samples that showed signs of settling had data points taken for 20 minutes while samples that did not show settling were only measured for 10 minutes. For the third experiment, all samples were run for the full 20 minutes. For each experiment, a measurement was taken at every minute for the first 5 minutes, and then every two minutes after that for 20 minutes. The last measurement of each cuvette was taken after the cells were agitated. This was done to check to see if the change of intensity was due to cell settling or cell death.

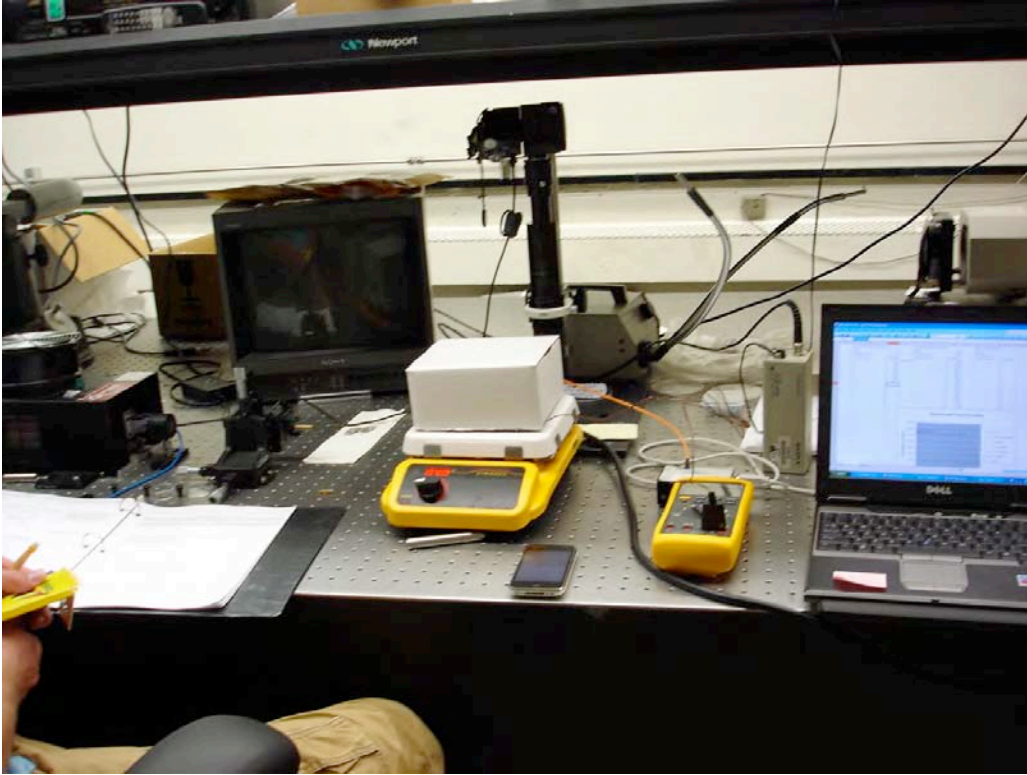

Figure 14: Image of Cuvette Experiment Set-up. Shown: Laser, Cuvette Holder in Incubator, Data Reader

B. Results

As mentioned previously, the first experiment did not yield reliable results. The results of the second experiment are shown in Figures 15 and 16; the results of the third experiment are shown in Figure 17 and 18. Figure 15 and 17 are the intensities of given suspension material with a PolyHEMA coating versus the time. Figure 16 and 18 are the intensities of given suspension material with a BSA coating versus the time.

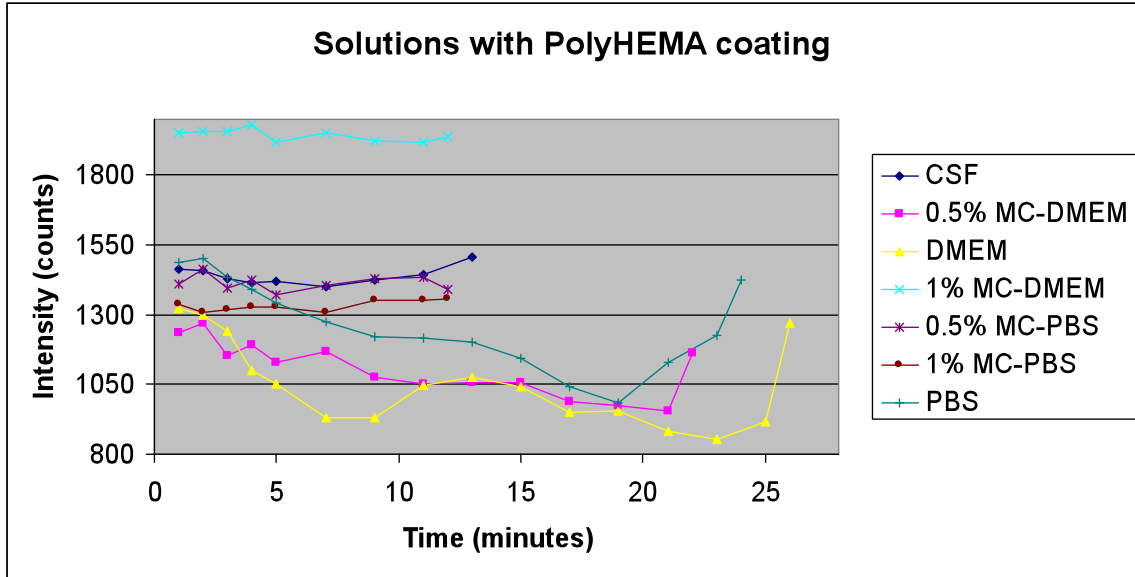

Figure 15: Experiment 2 - Suspension Material with PolyHEMA coating: Intensity versus Time

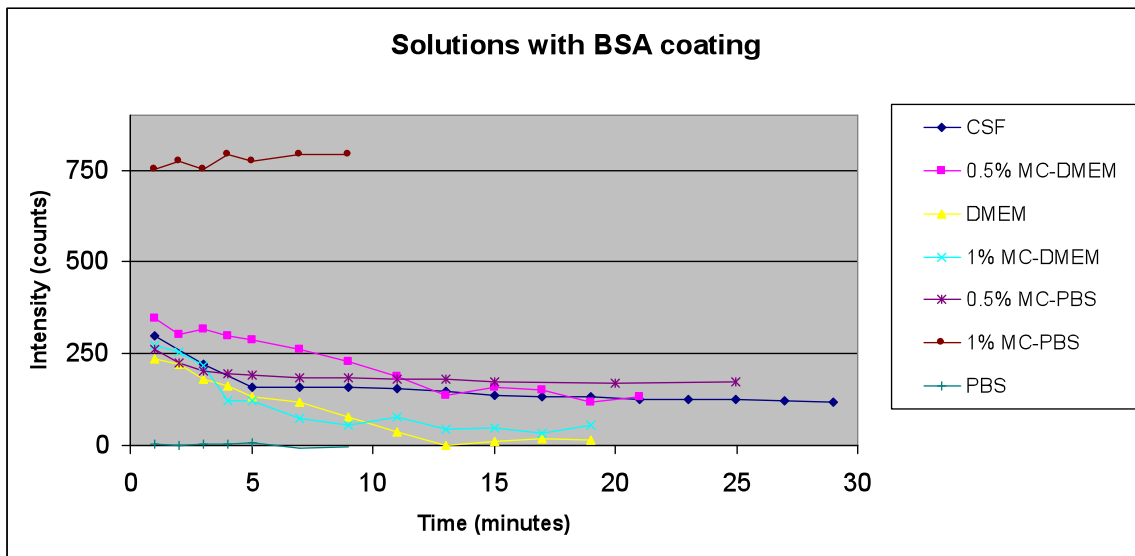

Figure 16: Experiment 2 - Suspension Material with BSA Coating: Intensity versus Time

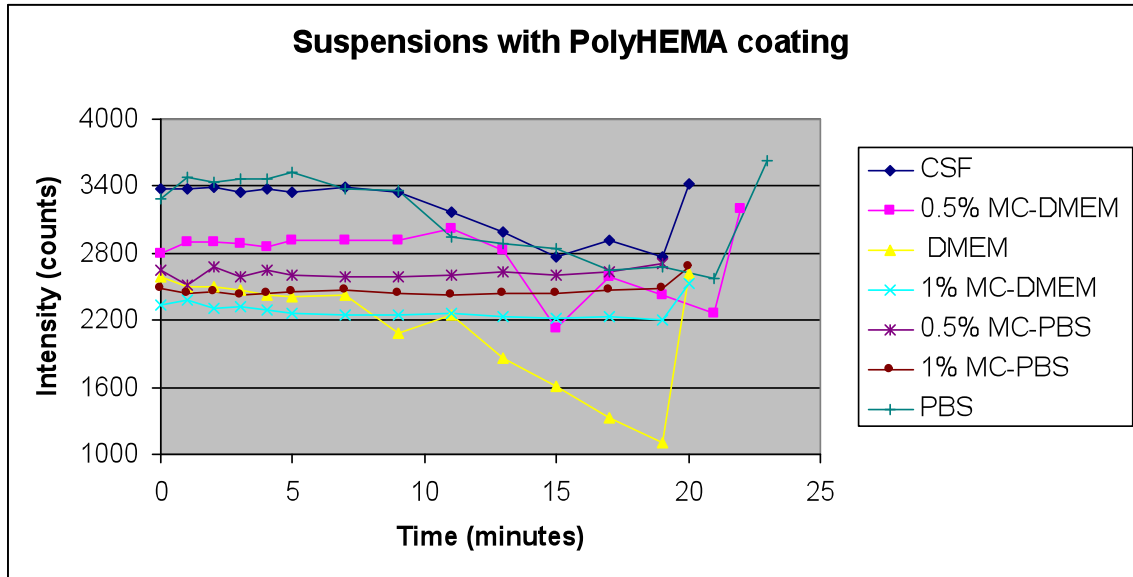

Figure 17: Experiment 3 - Suspension Material with PolyHEMA coating: Intensity versus Time

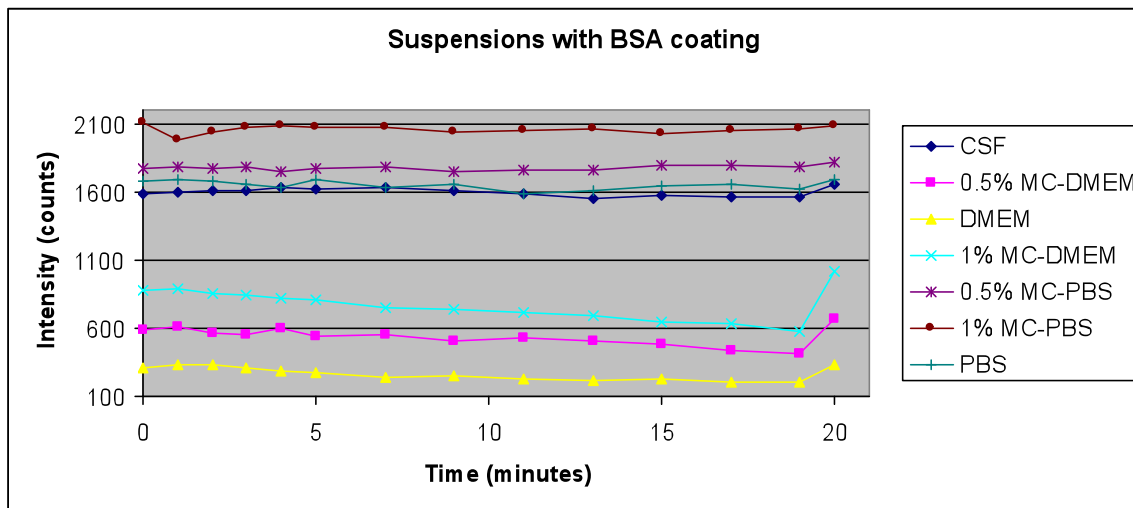

Figure 18: Experiment 3 - Suspension Material with BSA coating: Intensity versus Time

C. Discussion

As mentioned previously, the first experiment did not yield reliable results. The procedure was modified for the next two experiments in order to create a consistent experimental environment. The cells were given a more suitable environment by

incubating the CUV – ALL—UV™ set-up. Agitation was reduced between testing times by only testing one sample at a time.

An important aspect of the experiment was to identify the suspension materials which had background fluorescence. Knowledge of the background fluorescence would be useful when delivering the cells through the neural catheter. It is important that any background fluorescence be accounted for during cell excitation during future experimentation.

For each suspension material and coating, a blank and a cell sample were tested. In both experiments, solutions with DMEM components had background fluorescence. It was also noted that the fluorescence intensity of the DMEM solutions were reduced with the PolyHEMA coating in comparison to the BSA coating. In experiment 3, the background fluorescence of the DMEM solutions doubled in comparison to experiment 2. A different, shorter light-delivery fiber was used for experiment 3; this is believed to be the cause of the increase of fluorescent intensity. The other suspension materials and coatings had neutral fluorescent intensity, similar to the default intensity of the program.

Pure PBS and DMEM showed significant settling in all cases. One exception is shown in Figure 16; it is believed that the cells in the PBS solution had died, so there is no sign of settling. It was also noted that both coating methods, BSA and PolyHEMA, sufficiently kept the cells from attaching to the walls.

It was theorized that solutions with a higher concentrations of methyl cellulose would act as better suspension materials, due to the property of the compound. Methyl cellulose is significantly denser than PBS, promoting cells to remain suspended within the solution. This hypothesis was supported by experiment 2 and the PolyHEMA coating

of experiment 3. Generally, 1% methyl cellulose solutions in PBS and DMEM suspended the cells better than the 0.5% methyl cellulose in their respective solutions. The only deviation in this trend is shown in Figure 4. The cell settling in the 1% methyl cellulose in PBS solution was not significantly different from 0.5% methyl cellulose in PBS. In both PBS and DMEM solutions, increased concentration of methyl cellulose promotes better cell suspension. The only exception is the methyl cellulose in DMEM solutions with a BSA coating from experiment 2. All concentrations showed similar settling issues (Figure 16).

Comparing equal concentrations of methyl cellulose, the PBS solutions served as better cell suspension materials than DMEM. This is hypothesized to be due to the material properties of the combined solutions. During experimentation, it was noted that the methyl cellulose and PBS solutions acted more as a gel, while methyl cellulose-DMEM solutions acted more fluid-like. Gel-like material, such as the methyl cellulose in PBS solutions, would better suspend the cells, due to the fact that the cells would have difficulty moving freely throughout the solution. A fluid-like material, such as methyl cellulose in DMEM, would allow the cells to settle in solution.

In order to ensure that the decrease of intensity was not due to cell death, the last data points were agitated. These points were compared to the original intensity. If the intensity of agitated data points was less than the original intensity, it would suggest that the cells were dying in solution. In each experiment, the agitated intensity was close to the original measurement. In some cases, the agitated intensity was greater than the initial intensity. This suggests that the solutions should initially mixed more thoroughly in order to provide a reliable range of data.

In general, artificial CSF showed signs of settling. In the second experiment with BSA coating, the artificial CSF was vortexed before the first two data points were taken causing a drop in intensity (Figure 16). After seeing this significant drop, the solutions were no longer vortexed. Overall, the BSA coating of CSF showed a significant amount of settling; the CSF with PolyHEMA coating only showed slight signs of settling. The extreme settling of the CSF with BSA coating is believed to be due to the vortexing. In the third experiment, the BSA coating of CSF showed signs of suspension. The PolyHEMA coating showed settling after 10 minutes. With this data, it is difficult to ascertain the degree of settling artificial CSF would undergo, although it does appear that it would experience some cell settling.

The 1% methyl cellulose in PBS solution appeared to be the best solution to prevent cell settling. Increasing the amount of methyl cellulose in solution appeared to decrease the amount of cell settling. The PBS solutions were better cell suspensions than the equivalent DMEM solutions. The cells settled very quickly in pure PBS and DMEM. The cell settling effects of artificial CSF were difficult to determine, but it appears that the cells gradually settle. Coatings were invaluable in reducing the amount of cells on the cuvette walls.

13. Summary/ Conclusion

All of the goals of this project were successfully completed. The original prototype of the neural catheter was redesigned, allowing the device to be used in future animal studies. The fiber optic layout of the catheter tip was shown to effectively count cells.

As shown in the well-plate experiments, the presence of DMEM in the solutions promoted cell viability. Pure DMEM appeared to promote cell viability to the greatest extent. However, 1% methyl cellulose in PBS was also shown to be effective in promoting cell viability. It was also determined that coatings are required to sustain cell viability.

The 1% methyl cellulose in PBS provided the most effective suspension material; this was displayed in the cuvette experiments. It is suggested that 1% methyl cellulose in PBS would provide the best cell suspension material in terms of viability and effective suspension. The 1% methyl cellulose in PBS solution showed exceptional cell suspension properties and was also one of the few solutions able to show cell viability in the well-plate experiment. Another benefit is that neither material gives off a fluorescent signal when excited by the laser. This will benefit future experiments by providing a cleaner signal and easing data analysis.

14. Budget

MABE CAPSTONE DESIGN BUDGET Mechanical, Aerospace and Biomedical Engineering

Academic Year: 2008/2009 **Faculty:** Dr. Jack Wasserman

Project Title: Neural Catheter and Cell Suspension Design

Student Names:

Erik Bowman, Brad Meccia, Kaan Serpersu, Jennifer Watson

Project Narrative:

The group was tasked with designing and overseeing the fabrication of a neural catheter that could eventually be used for animal testing. The requirements for the catheter included: biocompatible, MRI compatible, fit the current methods of testing, make the

assembly process easier, lower fabrication costs, v-grooves for alignment of fiber optics to be used in cytometric measurements, less than 1/8 inch diameter, and compatible with sterilization methods.

The group was also tasked with researching and selecting the best cell suspension medium to be used in the delivery of 3RT1 cells. The cell suspension needed to be biocompatible, biodegradable, bioabsorbable, should not allow the cells to settle in the bottom of the suspension, and should allow the cells to disperse uniformly through the catheter.

The group has finished the design and has had 6 titanium catheters fabricated. Seven cells suspensions were chosen and their effect on cell viability and effectiveness of suspending the cells has been determined.

Budget:

a) Supplies (brief description and usage)

PBS (\$35.40), Dulbecco minimal eagle medium (\$21.50), Acrylic acid (\$79.57), Isopropylacryamide (\$209.57) – All used as potential cell suspensions

Catheter tips (6) - \$408, the designed catheter fabricated from Shular Tools

PEEK tubing 25ft (\$26.50), PVC 15ft and Heat Shrink tubing 6ft (\$7.50), Leur Locks (12) (\$5.00) – All used in final assembly with the catheters. The PEEK tubing serves as a bridge between the catheter and the PVC tube, with the heat shrink tubing being used to secure all pieces together. The Leur locks are placed at the opposite end and used to inject the 3RT1 cells through the PVC into the catheter.

Optical Fiber - \$60, attached to the catheter in 6 places, with two being cut at 45 degrees. Will pass a laser through where the strength will be measured by a computer.

Epoxy adhesive - \$31.55, used to attach the optical fibers to the catheters. UV light source needed to cure.

Polishing Paper - \$15, before being attached to the catheters all 6 of the fibers need to be polished in order for a clear signal to be measured.

Bare Fiber Adapter Kit - \$262, this kit was needed in order to hold the fibers in place for polishing.

Clauss Fiber Optic Inspection Microscope - \$239.97, microscope used to check to see if the fiber was fully polished.

Fluorospheres - \$230, before 3RT1 cells are used in testing, these fluorospheres are used in order to calibrate the testing apparatus.

Total Amount: \$1631.56

b) Student Travel

Purpose: To go to ORNL to build and test the catheter assemblies and test cell suspension materials in Dr. Boyd Evans's labs

Where: ORNL

When: Fall – Once a week for each member at least

Spring – Every Tuesday, Thursday, and Friday.

How many traveling: On Tuesday and Thursday – 3 students, Friday – 2 students.

Total Amount: \$400 for both Fall and Spring

c) Equipment (\$1,000 and up purchase; <\$1,000 per item goes under Supplies)

Description & Purpose:

ELC-410 Spot Cure System, \$935 a UV light source used to cure the UV epoxy.

CUV – ALL—UV, \$1047 – Cuvette Holder

Video microscope - \$2000, the fibers are about 250 microns in diameters. The microscope was needed in order to build the apparatuses, check fiber quality, and check laser route.

Nikon Diaphot 300™ - \$7600 Microscope with image capturing capabilities

Total Amount: \$11,942.00

d) Software (must be specific)

Ocean optics usp 2000 \$199 – used in testing to measure signal strength

Mechanical Desktop 2008 student version, \$0.00 – used to design catheter

OpenLab – Image capturing program, came with Nikon Diaphot

Total Amount: \$199

e) Others (brief description)

Purpose:

Total Amount: \$0.00

TOTAL BUDGET AMOUNT: \$14,172.56

15. Acknowledgements

We would like to first thank Mr. Haffner of the Haffner foundation who provided funding for this research. We would also like to thank Dr. Boyd Evans of Oak Ridge National Labs. Without his guidance none of this would have been possible. Thanks also go to Dr. Tim McKnight, whose help could not be understated, Dr. George Gillies and Jerry Brooks whose advice on the design documents was of great help, Dr. April McMillan, Dr. Helen Fillmore, and Dr. Jack Wasserman who all helped with some aspect of the project.

16. References

- [1] Parkinson's Disease Foundation. Ten Frequently-Asked Questions about Parkinson's Disease. Parkinson's Disease Foundation. New York, NY. www.pdf.org. 2006. Accessed March 2, 2009.
- [2] Eidelberg, D and Michael Pourfar. "Parkinson's Disease". Merck Manual of Diagnosis and Therapy. 18th ed, sec. 16, chap. 221. Retrieved March 23, 2009, from <http://www.merck.com/mmpe/sec16/ch221/ch221g.html#sec16-ch221-ch221g-75>.
- [3] CR Freed, PE Greene, RE Breeze, WY Tsai, W DuMouchel, R Kao, S Dillon, H Winfield, S Culver, JQ Trojanowski, D Eidelberg, S Fahn. Transplantation of embryonic dopamine neurons for severe Parkinson's disease. *N Engl J Med*. 344(10):710-9. 2001.
- [4] CR Freed, MA Leehey, M Zawada, K Bjugstad, L Thompson, RE Breeze. Do patients with Parkinson's disease benefit from embryonic dopamine cell transplantation? *J Neurol*. 250 Suppl 3:III44-6. 2003.
- [5] A Bjorklund, SB Dunnett, P Brundin, AJ Stoessl, CR Freed, RE Breeze, M Levivier, M Peschanski, L Studer, R Barker. Neural transplantation for the treatment of Parkinson's disease. *Lancet Neurol*. 2(7):437-45. 2003.
- [6] JH Kordower, TB Freeman, BJ Snow, FJ Vingerhoets, EJ Mufson, PR Sanberg, RA Hauser, DA Smith, GM Nauert, DP Perl, CW Olanow. Neuropathological evidence of graft survival and striatal reinnervation after the transplantation of fetal mesencephalic tissue in a patient with Parkinson's disease. *N Engl J Med*. 332(17):1118-24. 1995.
- [7] BM Evans, III, SW Allison, HL Fillmore, WC Broaddus, RL Dyer, GT Gillies. Cytometric catheter for neurosurgical applications.

- [8] HL Fillmore, J Shurm, P Furqueron, SS Prabhu, GT Gillies, WC Broaddus. An in vivo rat model for visualizing glioma tumor cell invasion using stable persistent expression of the green fluorescent protein. *Cancer Lett.* 141(1-2):9-19. 1999.
- [9] Mofid M.M, Thompson R.C, Pardo C.A., Manson P.N., Vander Kolk C.A, Persing J.A. Biocompatibility of fixation materials in the brain. *Plastic and reconstructive surgery* 100(1): 14-22.
- [10] Ritabh Kumar, Richard A. Lerski, Stephen Gandy, Benedict A. Clift, Rami J. Abboud. Safety of orthopedic implants in magnetic resonance imaging: An experimental verification. *Journal of Orthopaedic Research* 24(9): 1799-1802.
- [11]R. Buchli, P. Boesiger, D. Meier. 1988. Heating effects of metallic implants by MRI examinations. *Magnetic Resonance in Medicine* 7(3): 255-261
- [12]Matsuura, Hideki, Takashi Inoue, Hiromu Konno, Makoto Sasaki, Kuniaki Ogasawara, and Akira Ogawa. "Technical Note: Quantification of susceptibility artifacts produced on highfield." *J Neurosurg* 97:1472–1475, 2002.
- [13] Farahani K, Sinha U, Sinha S, et al: Effect of field strength on susceptibility artifacts in magnetic resonance imaging. *Comput Med Imaging Graph* 14:409–413, 1990.
- [14] Vezeau PJ, GF Koorbusch, RA Draughn, JC Keller, JE Lemons, and JE Lemons. "Effects of multiple sterilization on surface characteristics and in vitro biologic responses to titanium." *Journal of oral and maxillofacial surgery* 54(6): 738-746. 1996.
- [15] Hemmerich, Karl. "Polymer Materials Selection for Radiation-Sterilized Products". *Medical Device and Diagnostic Industry*. Feb 2000: 78.
- [16] Kurtz, SM and JN Devine. "PEEK Biomaterials in Trauma, Orthopedic, and Spinal Implants." *Biomaterials* Nov 28(32): 4845-4869. 2007.
- [17] Stewart, GJ, Yuqin W, and S. Niewiarowski. "Methylcellulose protects the ability of anchorage-dependent cells to adhere following isolation and holding in suspension." *BioTechniques* 19(4): 598-604. 1995.

17. Appendix

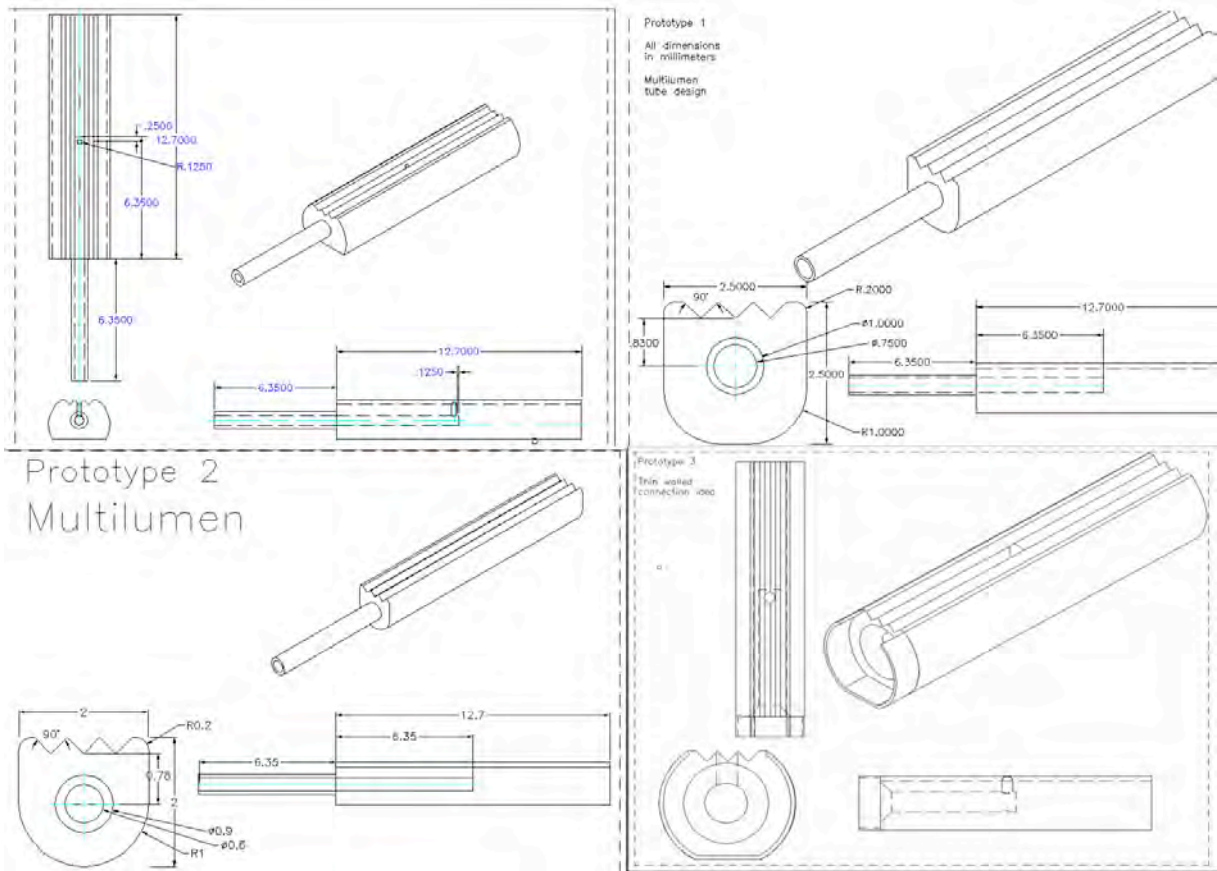

Appendix 1 – Montage of Initial Designs

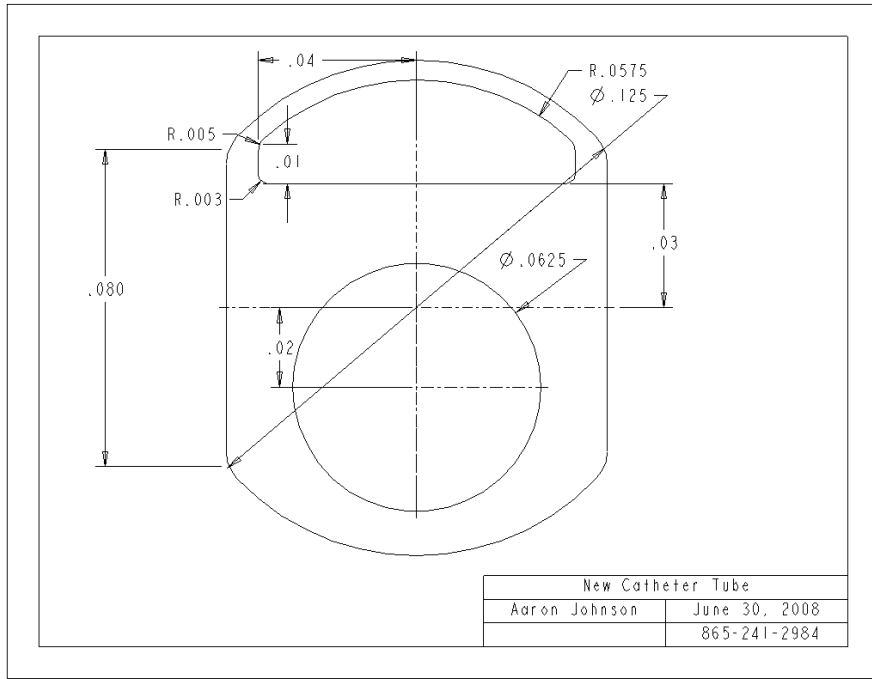

SCALE : 50.000 TYPE : PART NAME : TUBE3 SIZE : A SHEET 1 OF 2

Appendix 2 – Schematic of the Multi-Lumen Tube

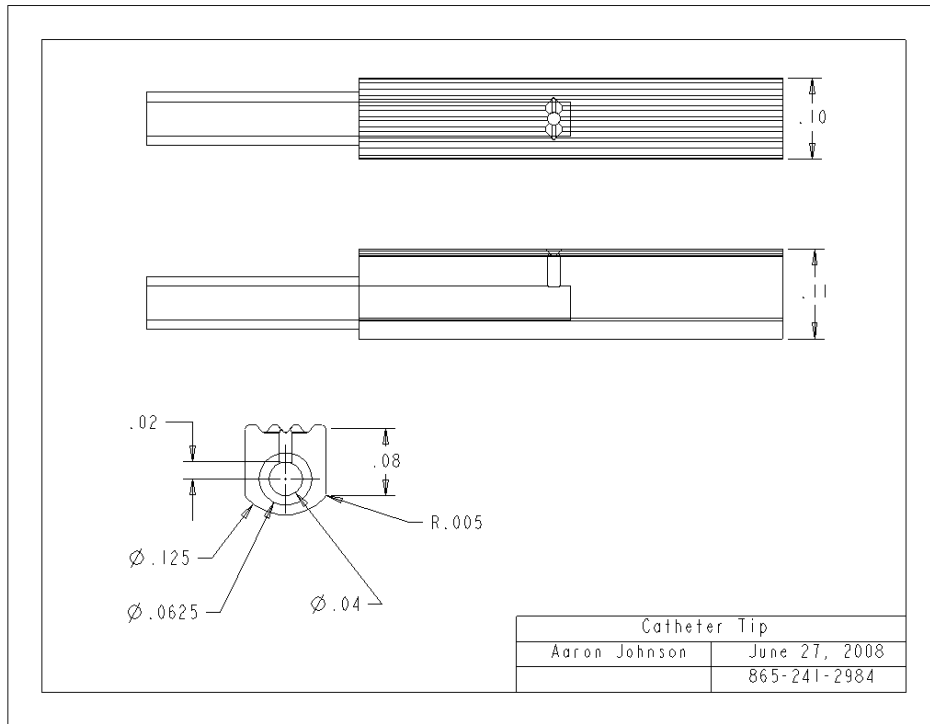

SCALE : 10.000 TYPE : PART NAME : 4THDRAFT_TIP_FLAT_OFFCENTERED_ SIZE : A SHEET 2 OF 2

Appendix 3 – Schematic of Original Design

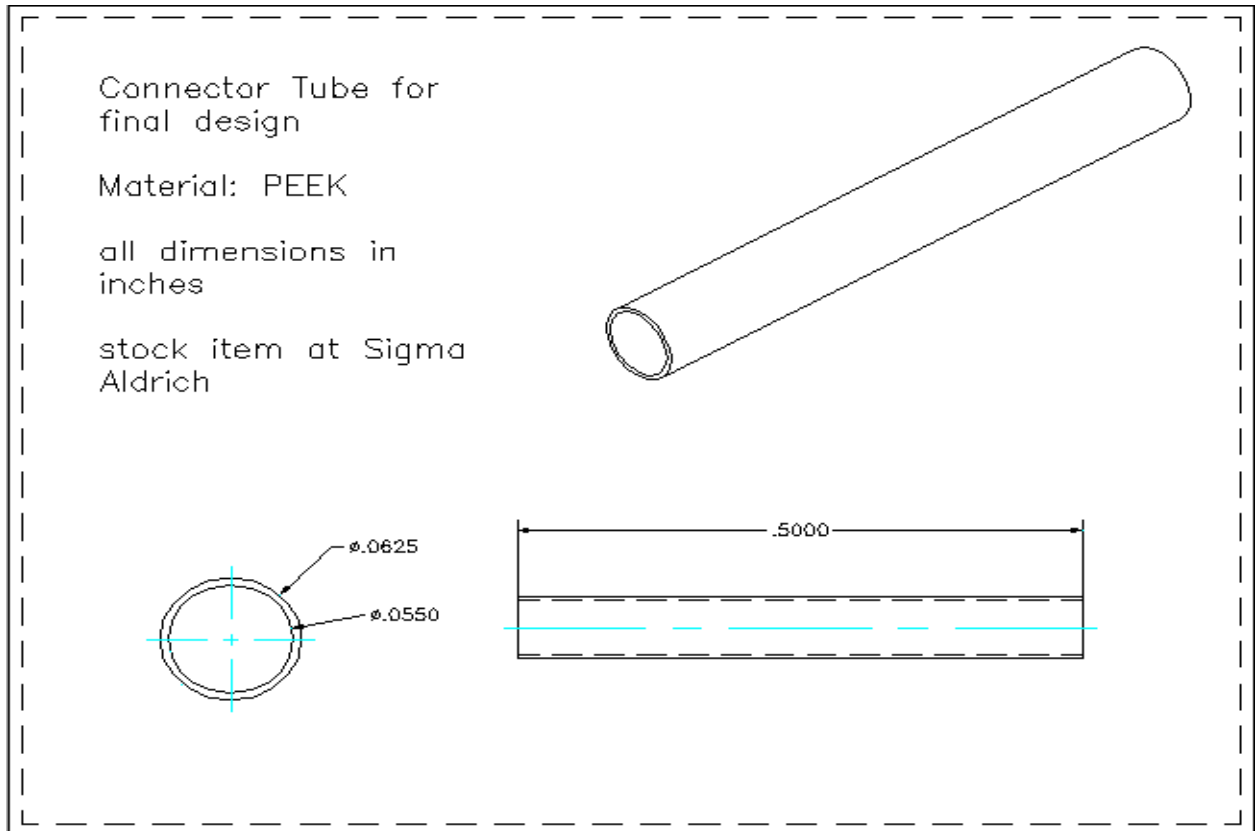

Appendix 4 – Schematic of the Bridge Tubing

18. Standards

ASTM F701 - 81(2008) Standard Practice for Care and Handling of Neurosurgical Implants and Instruments

ASTM F67 - 06 Standard Specification for Unalloyed Titanium, for Surgical Implant Applications (UNS R50250, UNS R50400, UNS R50550, UNS R50700)

ASTM F2026 - 08 Standard Specification for Polyetheretherketone (PEEK) Polymers for Surgical Implant Applications

ASTM F665 - 98(2003) Standard Classification for Vinyl Chloride Plastics Used in Biomedical Application

ASTM D2851 - 98(2004) Standard Specification for Liquid Optical Adhesive