



Spring 4-2004

# Experimental Analysis of a Fluidized Bed Reactor

David Lloyd McCollum  
*University of Tennessee - Knoxville*

Follow this and additional works at: [https://trace.tennessee.edu/utk\\_chanhonoproj](https://trace.tennessee.edu/utk_chanhonoproj)

---

## Recommended Citation

McCollum, David Lloyd, "Experimental Analysis of a Fluidized Bed Reactor" (2004). *University of Tennessee Honors Thesis Projects*.  
[https://trace.tennessee.edu/utk\\_chanhonoproj/769](https://trace.tennessee.edu/utk_chanhonoproj/769)

This is brought to you for free and open access by the University of Tennessee Honors Program at Trace: Tennessee Research and Creative Exchange. It has been accepted for inclusion in University of Tennessee Honors Thesis Projects by an authorized administrator of Trace: Tennessee Research and Creative Exchange. For more information, please contact [trace@utk.edu](mailto:trace@utk.edu).

UNIVERSITY HONORS PROGRAM

SENIOR PROJECT - APPROVAL

Name: David McCollum

College: Engineering Department: Chemical Engineering

Faculty Mentor: Dr. Duane D. Bruns

PROJECT TITLE: Experimental Analysis of a Fluidized Bed Reactor

I have reviewed this completed senior honors thesis with this student and certify that it is a project commensurate with honors level undergraduate research in this field.

Signed: Duane D Bruns Faculty Mentor

Date: April 29, 2004

Comments (Optional):

# Experimental Analysis of a Fluidized Bed Reactor

David McCollum

Senior – University of Tennessee, Chemical Engineering

Advisors:

Prof. Duane D. Bruns – University of Tennessee, Chemical Engineering

Dr. Stuart Daw – U.S. Dept. of Energy, Oak Ridge National Laboratory

Dr. Charles Finney – U.S. Dept. of Energy, Oak Ridge National Laboratory

Dr. Sreekanth Pannala – US Dept of Energy, Oak Ridge National Laboratory

May 3, 2004



## **ABSTRACT**

Fluidization is an area of major concern for the U.S. Department of Energy (DOE). Subsequently, a large amount of research is currently being conducted on fluidized bed reactors. These reactors have the potential to efficiently coat uranium particles. Particle coating becomes important in nuclear reactors, where the hope is that the coatings will allow the energy to be released from the uranium while simultaneously trapping the harmful radiation. Researchers have attempted to model the coating process through the use of computational fluid dynamics, and complex computer simulations have been developed. These models are only as accurate as their experimental foundation, however, so the current research thrust is to validate the models by experimental analysis. Thus, experimentation is the theme of this collaborative project between U.S. DOE Oak Ridge National Laboratory (ORNL) and the University of Tennessee (UT) Department of Chemical Engineering (ChE). Currently, experiments are being performed that will accomplish the goals set forth by ORNL. The particular fluidized bed reactor used in this study is in the shape of a cylinder (5.5" tall, 2" diameter) with a conical bottom (2" tall) and is constructed of glass. The current studies include velocity profiles at the bed exit, pressure fluctuations at the gas inlet, and particle image analysis. Future studies will include ozone conversion and temperature changes through the reactor. The Spring 2004 Fluidized Bed Team includes four UT ChE senior students—Codou Samba, Tokunbo Ademola, David McCollum, and Kristin Thomas—under the supervision of Dr. Duane D. Bruns. Together, the students have worked on the project as part of their ChE 410 Senior Laboratory course.

## INTRODUCTION

The secret of nuclear energy has been known for many years. Over this period, numerous advancements in efficiency, safety, and waste disposal have been made, but the public still has mixed feelings about the widespread use of nuclear energy. For all its critics, however, few can argue that nuclear energy is a non-greenhouse gas-emitting source of energy that has enormous potential for helping to solve some of the world's pressing energy problems. To this end, engineers and scientists are perpetually trying to refine the nuclear fusion and fission processes, while at the same time making these processes safer for humans and the environment. Some current work that is gaining worldwide attention is the coating of uranium particles for use in nuclear reactors. Uranium is virtually always used as a reactant in nuclear reactors, and it is able to release huge amounts of energy and generate very high temperatures. At the same time, however, a large amount of harmful radiation and fission by-products are released from the uranium. For this reason, researchers are interested in putting an organic coating around the uranium fuel particles (see Figure 1), which would allow the high energy to be released, while trapping the harmful radiation and by-products.

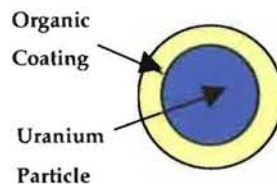

*Figure 1:* Organically-coated uranium particle

So then the question becomes one of “how,” instead of “why.” In other words, “How does one efficiently coat uranium particles?” One answer is through the use of spouting fluidized bed reactors, and researchers across the world, including the U.S. Department of Energy, are currently studying this very technique. Much of the work in this field is proprietary. In fact, some German scientists claim to have solved the mystery of efficiently coating uranium particles, but they have not yet released their secret process to the general public. In the meantime, the rest of the world is trying to catch up by studying fluidized bed reactors in earnest.

Fluidized bed reactors come in different shapes and sizes. Some are round; some are square. Some have a conical bottom; some have a flat bottom. Some are wide; some are tall. In general, the size and shape depend on the particular application. For example, some fluidized beds used in the production of polyethylene are 20 feet in diameter and 30 feet tall. Fluidized

beds are used to dry corn and wheat and to coat time-release fertilizers in agricultural applications. They are also used to coat medical pills in the pharmaceutical industry.

The reactor used in this particular UT-ORNL collaborative research project has a cylindrical body and a tapered, conical bottom (see Figure 2).

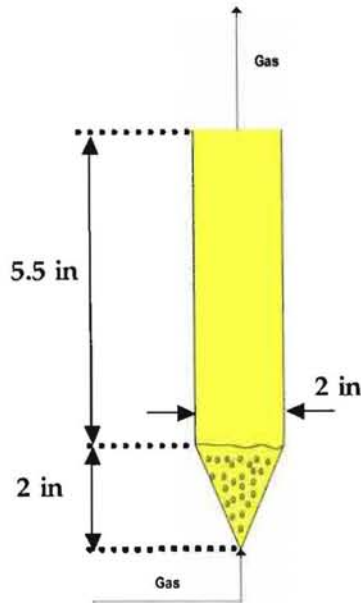

*Figure 2:* Fluidized Bed Reactor used in ORNL-UT ChE project

Another example of a fluidized bed that has been studied by UT and ORNL is in the shape of a rectangular prism. This reactor is known as a 2-D bed, because its dimensions in two of the directions are much larger than the third (see Figure 3). A background gas flow is provided across the entire bottom of the bed which slightly levitates the particles. It has another gas injector in the center where additional gas is added; this makes the 2-D bed similar to the cylindrical bed with a conical bottom.

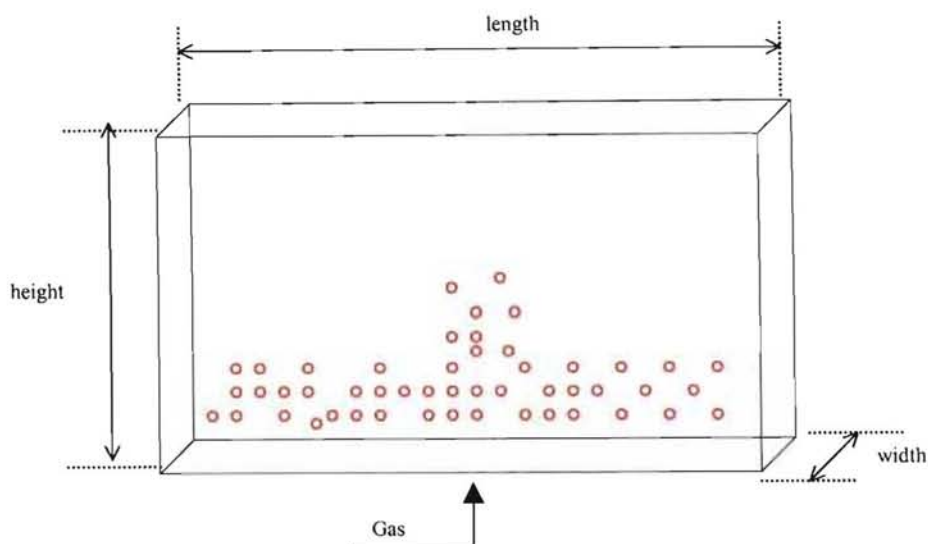

*Figure 3: 2-D Fluidized Bed Reactor*

Current fluidized bed reactor studies are being carried out at ORNL that use real uranium particles and involve extremely high temperatures—conditions that are expensive and can be dangerous for inexperienced researchers. For this reason, the experiments of this study were carried out under much safer operating conditions and did not make use of the radioactive uranium particles. Instead, the particles in these experiments are zirconium oxide spheres in the sizes of 300  $\mu\text{m}$ , 500  $\mu\text{m}$ , and 1000  $\mu\text{m}$ . This material has been chosen because some of its physical properties are similar to uranium. As can be imagined, it is difficult to perform experiments at one set of conditions and then predict what will happen at some much different set of conditions. The bridge between the different experiments is computational fluid dynamics simulation. These complex computer models, when based on reliable experimental data, are extremely helpful in predicting results at other conditions. Therefore, the main purpose of this particular research project was to gather a multitude of experimental data, which could then be taken back to the ORNL researchers who want to validate and improve their computer simulations. In sum, this research project is just one piece of the particle-coating puzzle.

Throughout the Fall 2003 semester, the fluidized bed team worked on designing and constructing the fluidized bed set-up for the ORNL-UT ChE project. First, a literature search was conducted, and it was found that some Australian scientists had previously studied the decomposition of ozone in fluidized bed reactors about 30 years ago (Fryer 1974). The team initially decided to replicate this work with the hope of determining the kinetics of the reaction and mass transfer coefficients for the particles in the fluidized bed. As is usually the case, however, the goals of the project changed over time. Then, in January 2003, three more UT ChE

undergraduate students joined the fluidized bed team—Codou Samba, Tokunbo Ademola, and Kristin Thomas. The team is shown in Figure 4.



*Figure 4:* Spring 2004 fluidized bed reactor team  
(From left: Dr. Duane Bruns, Tokunbo Ademola, Codou Samba, Kristin Thomas, and David McCollum)

Together, the four seniors and Dr. Bruns have worked on the project as part of their ChE 410 Senior Laboratory course. The initial plan was to conduct various studies on the fluidized bed reactor. These studies included ozone conversion, velocity profiles, temperature changes, pressure fluctuations, and particle image analysis. The first priority, however, was to develop a sound experimental strategy that would minimize the adverse effects of static electricity on the walls of the glass reactor. (This effect had been observed in earlier studies.) After this, the pressure sensors, velocity anemometer, and digital camcorder were used to characterize the particle behavior at different flow rates, particles loads, and particle sizes. Before any of these studies could be undertaken, however, an experimental system had to be designed and built.

## **EXPERIMENTAL SET-UP**

The most important piece of experimental equipment, the glass fluidized bed reactor, was fabricated by the ORNL glass shop and loaned to UT ChE for use throughout the duration of this project. Doug Fielden and others in the UT ChE-MSE (Materials Science and Engineering) Machine Shop have also built a gas inlet section, outlet section, and metal frame for the reactor. This inlet and outlet sections, which are both constructed out of Poly(methyl methacrylate), PMMA, and serve to hold the reactor in place. The bottom piece has an inlet for the gas stream, an outlet for the zirconium oxide particles, and an interchangeable port for a pressure sensor or other measurement device. The top piece has four measurement ports—one for a thermocouple, pressure sensor, and velocity anemometer, and a fourth port as a spare. Above the top piece can



be placed several different modular pieces, which can be added or removed depending on the particular experiment at hand. One of these modular pieces, for example, is simply a cylindrical extension so that the higher spouting particles do not fly out of the top of the reactor at high flow rates, which they are prone to do. Another modular piece serves to hold a prism, so that the researcher can get a “bird’s eye view” of the particles by looking down into the top. All of these pieces are connected to the metal frame, which securely fastens all of the elements together. Levelers complete the design to ensure that the reactor is level at all times.



*Figure 5:* Fluidized Bed Reactor, frame, and modular pieces in hood



*Figure 6:* Left view



*Figure 7:* Front view

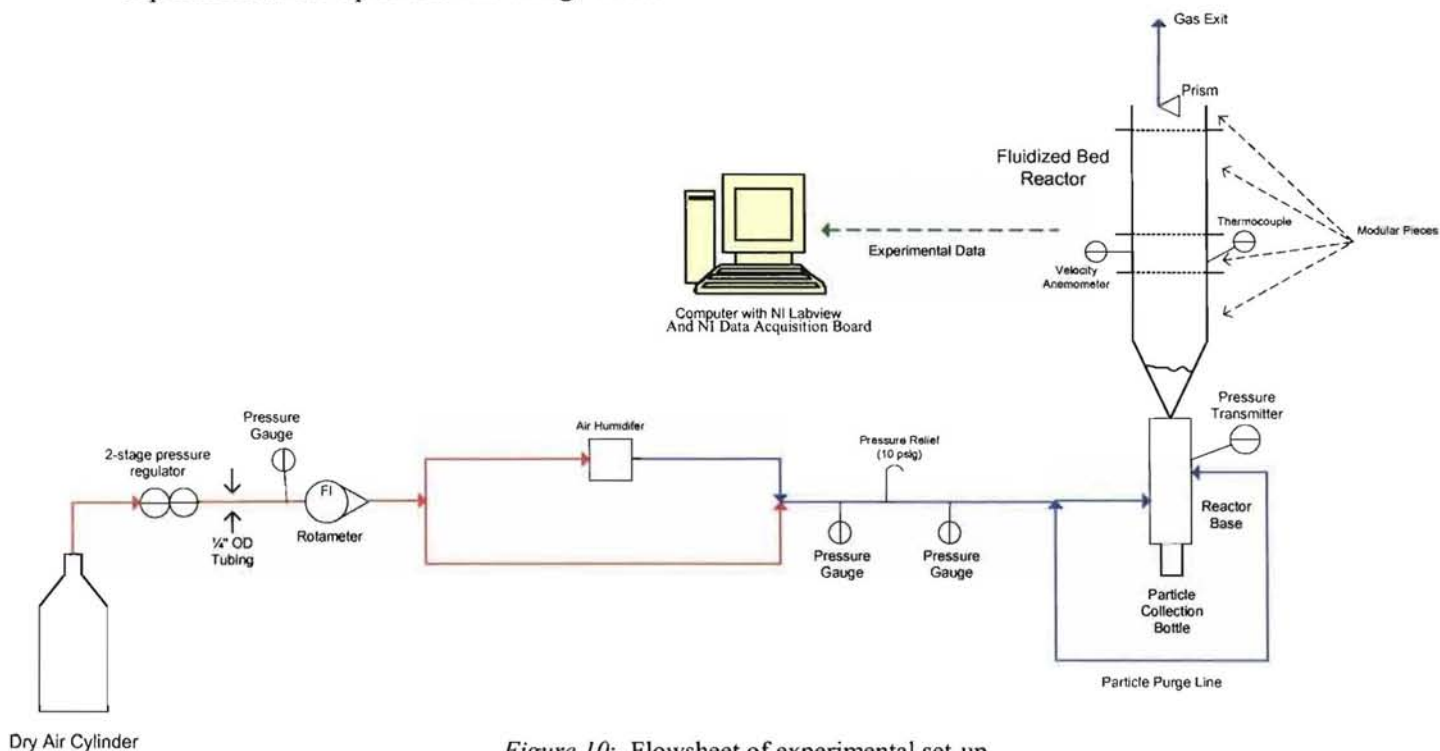

*Figure 8:* Right View



*Figure 9:* Bottom piece

Air is fed to the base of the reactor and is accelerated upwards, through the conical section, and out the top of the reactor. This air comes from a dry air cylinder. Other pieces of experimental equipment are between the air cylinder and reactor. For clarity, a flowsheet of the experimental set-up is shown in Figure 10:



*Figure 10:* Flowsheet of experimental set-up

As mentioned previously, the dry air comes from an interchangeable, high-pressure air cylinder, which is rented from a local supplier. The air then passes through a bank of valves, fittings, pressure gauges, and rotameters, which have been affixed to a sturdy piece of metal—a flow panel. A picture of the air cylinder and flow panel are shown in Figure 11:



*Figure 11:* Dry air cylinder and flow panel

The pressure gauges and rotameters of the flow board allow the operator to gather important information about the state of the system, for example, air pressure and flow rate. Thermometers in the room give the current air temperature, and since it can be assumed that the air in the feed lines is in thermal equilibrium with the ambient air, the temperature of the air exiting the reactor is also known. Further, relative humidity sensors placed at the exit of the reactor give the amount of water vapor in the air. With all of these variables known for a given experimental run, the system is very well characterized.

From the flow board, the air traverses through about 10 feet of ¼" OD (outer diameter) tubing before making its way to the reactor. The air enters the reactor base from the left side, which is shown clearly in the previous figures. Once the air is inside the reactor base, it travels at a 45° angle down to the center, before reversing directions and heading directly vertical. At the top of this short vertical section, the air enters the reactor and mixes with the particles. From the figures, also notice the particle collection bottle at the bottom of the reactor base. This bottle serves to catch the particles when the air is turned off. The purpose of the black, circular valve on the right side of the reactor base is to keep particles in the bed when the air is turned off by having the valve closed. When the valve is opened, the particles are allowed to fall down into the collection bottle.

From the flowsheet, it should be clear that the experimental data is collected via a National Instruments, Inc. data acquisition board, which is then fed to a desktop computer. Specifically, the data acquisition board is the National Instruments model SCB-68, and the Dell computer is operating on a Windows 2000 platform. Pressure data was collected using a Baratron pressure transducer, with a measurement range of 0-50 inches of H<sub>2</sub>O. This transducer outputs a 0-5 VDC signal, which linearly corresponds to the measurement range. The time constant of the sensor is 100 Hz. On the other hand, the velocity data was collected using an Omega Engineering velocity anemometer, with a measurement range of 0-1000 feet/minute. This sensor outputs a 0-5 VDC signal. The time constant of the sensor is 2.5 Hz. A picture of the pressure sensor collecting data from the reactor is shown in Figure 12:



*Figure 12:* Pressure sensor collecting data from reactor

As the output data streams from the sensors to the data acquisition board and on to the computer, some software must be used as an intermediary between the computer and the researcher, so that the data is organized into something that can be understood and used later. National Instruments's LabVIEW 7.0 was the software of choice in this project. LabVIEW is a graphical programming language that is much quicker to learn than a more traditional text-based programming language. Instead of typing in computer code—like in Matlab, C++, or Fortran—the coder simply selects certain blocks (which represent different routines) and then connects these blocks with arrows (the data streams). Figure 13 shows an example of a LabVIEW block diagram:

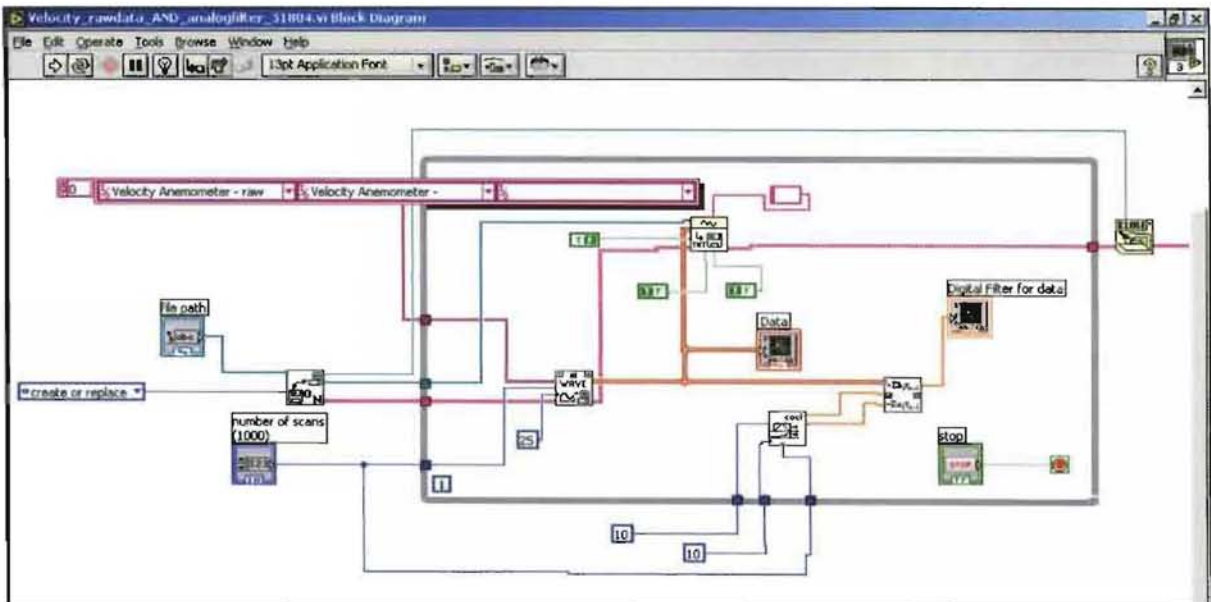

*Figure 13:* LabVIEW Block Diagram

The computer code that underlies the block diagram serves several purposes. For one, it logs the data into data files, so that the researcher can go back at a later time and analyze it. In addition, the block diagram code is able to display the current sensor readings on a user interface screen, which is important for real-time measurement and control of the experimental system. Figure 14 shows a screen capture of a typical LabVIEW user interface:

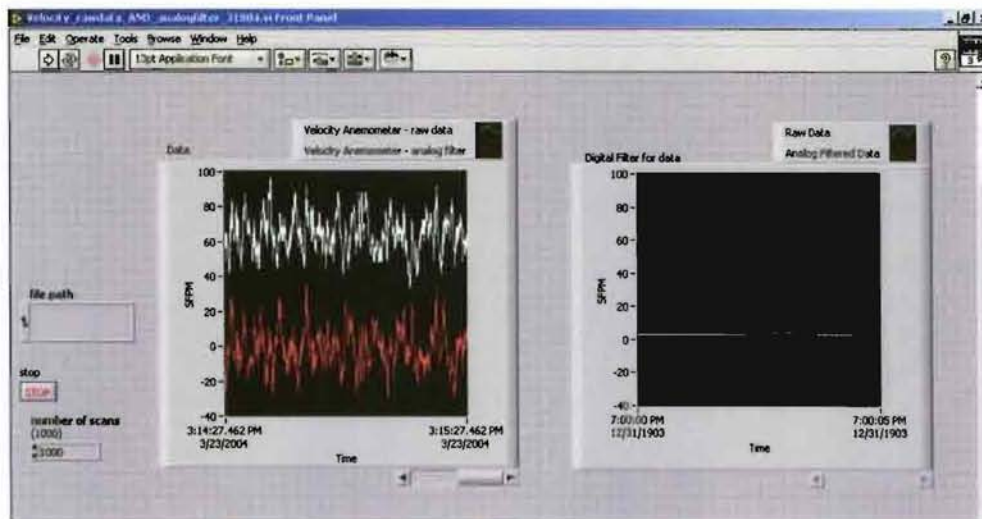

Figure 14: LabVIEW User Interface

The data acquisition software and equipment set-up is vitally important in these experiments, for the pressure fluctuations that occur on a very short time scale are of great interest. Without the high-speed equipment, no reliable results could be obtained.

## EXPERIMENTAL PROCEDURE

At the beginning of the Spring 2004 semester, a list of goals was constructed that contained items to be accomplished by experiments involving the fluidized bed reactor. Among the desired objectives were to measure pressure fluctuations at the bed inlet for various particle sizes, materials, and loads; measure gas velocities across the diameter of the fluidized bed reactor; analyze bed hydrodynamics with digital video and imaging software; and use MATLAB to analyze the pressure and velocity readings that were gathered and video images that were taken using the digital camera.

The experiments that were conducted can be split into five campaigns, two of which consisted of gathering pressure data, two gathering velocity data, and one gathering pressure data while simultaneously videotaping the reactor. Throughout each campaign, the general laboratory

procedure remained the same, only differing slightly depending on which type of data was being collected. Both computer data acquisition and manual recording of data took place, and such variables as air temperature, flow rate, humidity, particle spout height, and the presence of static were noted. In each campaign involving particles in the reactor, several values remained constant, including particle material, weight, and size, which were zirconium oxide, 60 grams, and 300 microns, respectively. The pressure experiments used a data acquisition rate of 1000 Hz, an analog filter high pass set point of 0.1 Hz, and an analog filter low pass set point of 500 Hz. The velocity experiments used 25 Hz data acquisition rate, 0.1 Hz high pass set point, and 500 Hz low pass set point. The video/pressure experiments used a 200 Hz data acquisition rate, 0.1 high pass set point, and 40 Hz low pass set point.

#### Campaign 1 – Pressure Measurements with Dry Air

The first campaign involved taking pressure data at three different flow rates, five runs at each of the flows, ten minutes between each trial, and four minutes of data collection for each run. Once the particles were measured out, the air flow rate was set to 4 SLPM (the low flow condition) and the corresponding pressure was documented at approximately 30.8 psi. Throughout the five trials at this flow, the maximum spout height was around 1.25 inches, the minimum at 0.5 inches, and the average at 0.75 inches. Some static build up was observed but had dissipated by the end of the fifth trial.

The high flow condition corresponded to a setting of 9.1 SLPM and a pressure of 30 psi. The maximum spout height was approximately 4.5 inches, the minimum at 2 inches, and the average at around 2.5 inches. The amount of static particles built up on the walls of the reactor was much more substantial at this flow, sometimes as great as 1.5 inches above the top of the bed.

The last part of the campaign involved data collection returning to the lower flow rate of 4 SLPM. A very large amount of static remained even when the flow rate was decreased, and even by the end of the fifth trial of this particular section, the height of static particles was still as high as 1.75 inches along some parts of the wall of the reactor.

#### Campaign 2 – Pressure Measurements with Moist Air

The second campaign was an extension of the first in that the same laboratory set up and procedure were used, but the air from the air cylinder entered a humidifier before flowing into the reactor. This would aid in the investigation to see how humidity affected the amount of static incurred inside the fluidized bed reactor. Sixty grams of 300-micron particles were once again

measured out, and the flow rate set at 4 SLPM and 30.8 psi. This time, the air humidity ranged from 22 to 43%, and the amount of static was greatly decreased.

After five runs of data collection, the flow rate was set at the high point of 9 SLPM and 30 psi. The relative humidity averaged at about 20% throughout the next five trials, and although static began to build up after approximately five minutes, it was much sparser than in those runs conducted with dry air.

In the final section of this campaign, the humidifier was placed on a hot plate and the high flow rate conditions were maintained. Relative humidity readings were in the range of 40 to 45%, which proved to be optimal operating conditions for running the reactor with minimal static. In this case, there was no noticeable static buildup in the fluidized bed reactor.

### Campaign 3 – Velocity Measurements Across the FBR

Once the pressure data was taken, the next two campaigns focused on the collection of velocity data both with and without particles and at low, medium, and high flow rates. The first part of the third campaign was conducted with 60 grams of 300 micron particles, as before, with a flow rate of 4.5 SLPM, and an air pressure of 31 psi. Measurements were taken in even increments starting at the center of the reactor (one inch from either side) and then moving towards the back wall 0.25 inches, 0.5 inches, and 0.625 inches from the center. Measurements were then taken on the other side of center at 0.5 inches and one inch (i.e., at the near wall).

These same steps and same increments were repeated at a flow rate of 6.5 SLPM and 30.8 psi pressure (medium flow rate) and then finally at 11 SLPM and 30 psi (high flow rate). In this way, velocity profiles across the diameter of the reactor could be compared for each of the flow rates.

The final part of the third campaign consisted of duplicating all of the above steps, except without the particles in the reactor. Measurements were taken at the same six increments at the low flow (4.5 SLPM, 31.9 psi), at the medium flow (6.5 SLPM, 31.5 psi), and at the high flow (11 SLPM, 30.7 psi). Once again, the main objective was to compare velocity profiles across the reactor.

### Campaign 4 – Velocity Measurements Across a Straight Pipe

The fourth campaign of laboratory experiments was an extension of the investigation started during the third campaign. This time measurements were taken without particles across the diameter of a straight pipe with the same 2" ID as the reactor, but with a much longer length. In this way, the entrance of the air was further from the point of the velocity probe (greater than



10 pipe diameters) in order to eliminate any entrance effects that may have been present in the previous velocity experiments.

The same steps were followed as before with six increments starting at the center of the pipe, moving 0.25 inches, 0.5 inches, and 0.625 inches away from center towards the far wall, and then 0.5 inches and one inch away from center towards the near wall. The same three levels of flow rates were incorporated as well with low flow being 4.5 SLPM and 31 psi, medium flow being 6.5 SLPM and 29.9 psi, and high flow set at 11 SLPM and 29 psi. Using the information gathered from the third and fourth campaigns, observations could be made on the basis of how entrance effects influence the velocity in the fluidized bed reactor.

#### *Campaign 5 – Simultaneous Video Collection and Pressure Measurements with Moist Air*

Finally, the fluidized bed reactor was videotaped with two cameras so that both side and top views could be obtained over two minute time spans. In addition, pressure data was simultaneously collected. These experiments consisted of 5 runs: 9.5 SLPM and 30.6 psi; 8.3 SLPM and 31.1 psi; 6.9 SLPM and 31.5 psi; 6.3 SLPM and 31.8 psi; and 4.8 SLPM and 32.1 psi. In each of the experiments, the particle loading was 59.9 grams of 300-micron particles. The humidity ranged from 40-50% over the course of the experiments, and virtually no static was observed.

## **RESULTS AND DISCUSSION**

The initial results of this project span more than just the experimental data obtained. The experimental set-up, in and of itself, is a tangible result that took a full semester to come to fruition. And since this particular UT-ORNL project is in the very early stages of development, the experimental procedure is yet another tangible result. In the future, other researchers will use these procedures and equipment to gather additional experimental data.

Some of the very first, qualitative experiments on the fluidized bed reactor were conducted in the Fall 2003 semester. In these experiments, the various-sized particles were placed in the reactor and the airflow simply turned on, so that a general idea of the mixing patterns and flow behavior could be observed. In addition, a few particles were colored either red or black so that their flight trajectory could be more easily tracked with the naked eye. On one occasion, short movie clips were recorded of the 500-micron particles at different flow rates; select still frames of these clips are shown in Figures 15 and 16:



*Figure 15:* Fluidized bed reactor (~20 LPM airflow)



*Figure 16:* Fluidized bed reactor (~30 LPM airflow)

From the snapshots of the fluidized bed in action, one can see marked difference between the two flow conditions. At the lower flow rate, it is clear that the particle hydrodynamics exhibit a “water fountain” effect, with a high velocity air jet in the middle and the particles falling off to the sides once they reach their peak height. The particles then make their way to the bottom of the reactor by falling along the walls until they are yet again entrained in the high velocity air jet and accelerated upwards. On the other hand, slightly different behavior is observed at the higher flow rate. The high velocity jet continues to accelerate the particles upwards, but the presence of the walls of the reactor interferes with the flight trajectory of the particles, causing them to hit the wall and fall to the bed of particles before they would otherwise naturally fall to the surface of the bed. The central question is: “Which one of these flow patterns is favored?” Remember, the main objective is particle coating.

As mentioned previously, high-speed pressure measurements were taken at the base of the reactor, where the air first comes in contact with the particles. Pressure measurements of this type have been collected and analyzed for other fluidized beds. In many of these systems, the pattern of pressure signals is similar, making it possible to characterize the hydrodynamics of the particles (and perhaps mixing patterns?) with measurement of pressure. A plot of a typical pressure time series is shown in Figure 17:

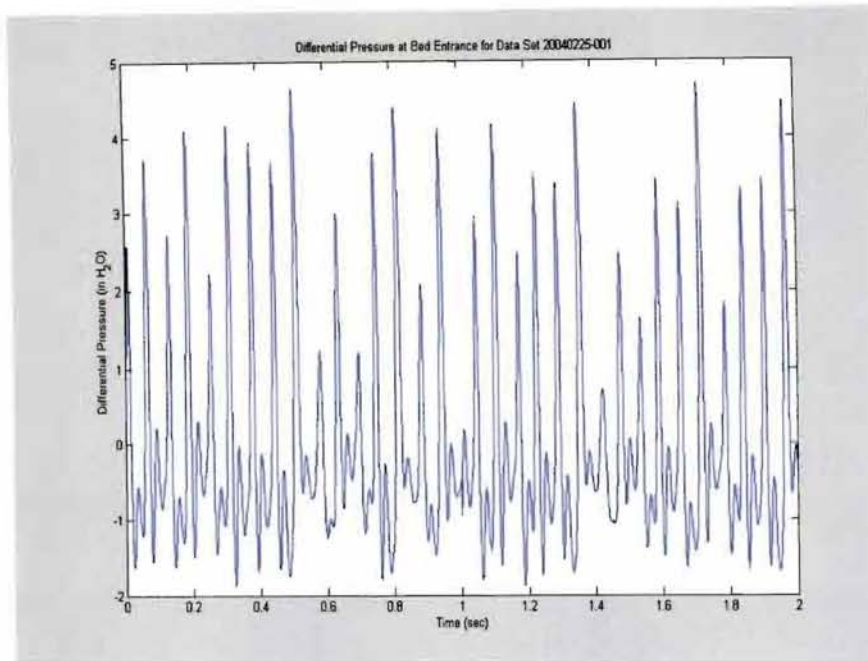

*Figure 17:* Pressure time series for fluidized bed reactor

From the plot of the pressure time series, one immediately notices the oscillatory nature of the pressure signal (i.e., the pressure is high, low, high, low...etc.). Each of the peaks corresponds to the particles spouting in the bed. More specifically, the big peaks correspond to a big spout, and the little peaks correspond to a small spout. What generally happens in the reactor for a given flow rate is that the particles shoot upwards and then fall back down, as described previously. The height of the particle spout is not constant, however; in fact, it is high, low, high, low...etc., which directly corresponds to the pattern of the pressure time series! If one were to count up the number of peaks in the previous figure from 0 to 1 second, and then again from 1-2 seconds, there would be about 30 peaks for each one-second interval. 30 peaks in one second correspond to a pressure frequency of 30 Hz (1 Hz = 1 peak/second). But the pressure frequency changes over the course of a given run, even when the operating conditions are constant. It is possible to calculate a probability distribution of the pressure frequencies (i.e., which frequencies occur more than others). This is known as a power spectral density function (PSD). A PSD plot for the data set in the previous pressure time series is shown in Figure 18:

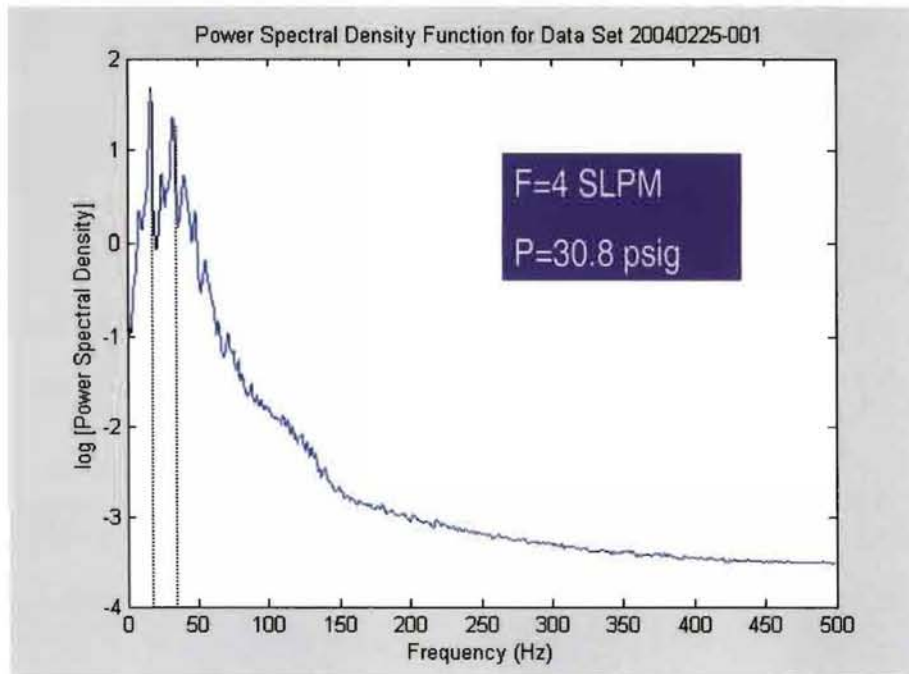

*Figure 18:* PSD plot for pressure frequencies at 4 SLPM

From the PSD plot above, it is clear that the most probable frequencies at this particular operating condition are around 25 and 40, with some other probable frequencies in the range between 25-40 and just slightly above and below it. There is virtually no probability that the pressure frequencies are 100 Hz or higher. Another PSD plot for a different set of operating conditions is shown in Figure 19:

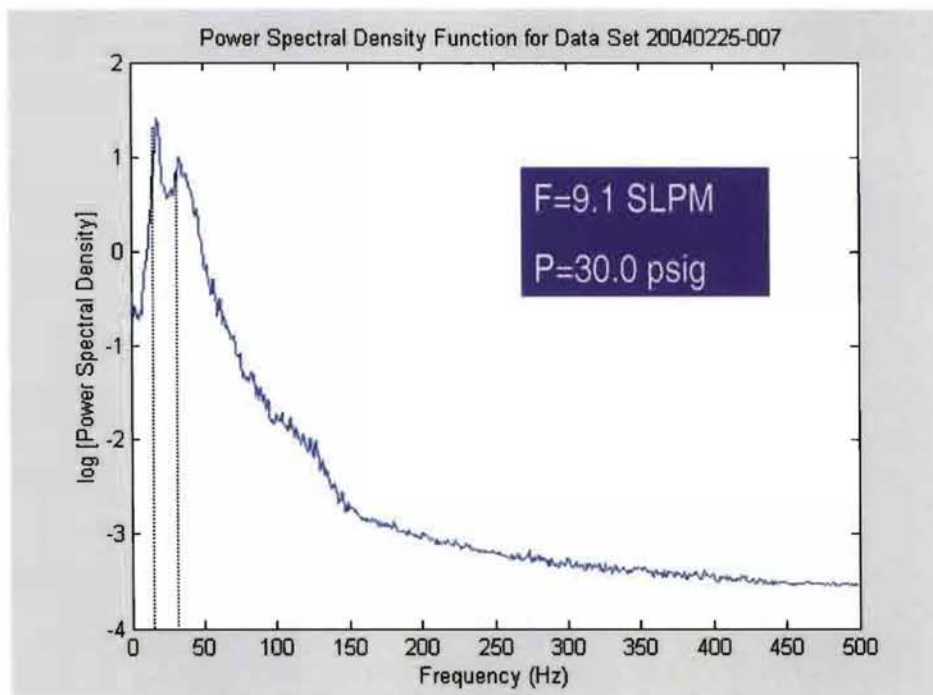

*Figure 19:* PSD plot for pressure frequencies at 9.1 SLPM

As before, the most probable frequencies at this particular operating condition are around 25 and 40, but this time the shape of the curve is different. Specifically, there are two broader peaks, with no other peaks to speak of. Again, there is virtually no probability that the pressure frequencies are 100 Hz or higher.

As more pressure time series are generated for different operating conditions, it may eventually be possible to predict how the particles in the bed will behave simply by taking pressure measurements. This becomes important in fluidized beds that are made of an opaque material that cannot be seen through, which is the case in some high-temperature graphite reactors at ORNL. In these reactors, a prism is used to look down into the reactor from the top; this is the only visual information that can be gathered, since no side view is available. Herein lies a significant advantage of the fluidized bed reactor used in this UT project. As seen in some previous figures, the reactor is made of glass and can obviously be seen through. Thus, the behavior of the particles can be viewed through the side. In addition, a prism is available to look down through the top. As mentioned previously, one set of experiments involved the simultaneous videotaping of the top and side views of the reactor at different operating conditions. Snapshots of the videotapes are shown Figures 20-23:

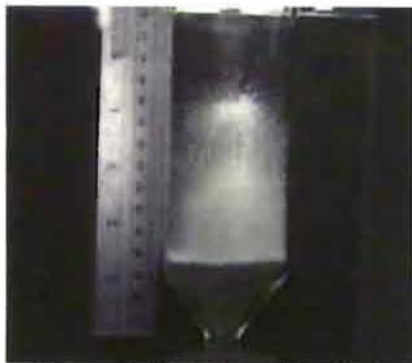

*Figure 20: High flow (side view)*



*Figure 21: High flow (top view)*



*Figure 22: Low flow (side view)*

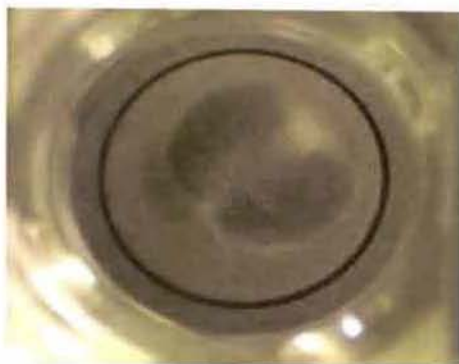

*Figure 23: Low flow (top view)*



At the same time that the reactor was being videotaped, pressure measurements were being recorded. After some future data analysis, the hope is to correlate the pressure signals with the particle hydrodynamics. This will hopefully help in the prediction of the hydrodynamics in the uranium coating reactors.

In addition to pressure, velocity measurements were also recorded at various operating conditions. The velocity was measured at the exit of the reactor and at different points across the diameter. The hope was to generate a velocity profile for the airflow inside the reactor. Nearly all of the experimental runs used flow rates where the average air velocity was low enough to allow for laminar flow (i.e., Reynold’s number below 1800). For laminar flow, the velocity profile should have a symmetrical, parabolic shape with a maximum at the center and zero at the walls. The flow profile obeys the following equation:

$$v = v_{\max} \left[ 1 - \left( \frac{r}{R} \right)^2 \right]$$

where  $v_{\max}$  is the velocity at the center;  $r$  is the radial position, and  $R$  is the radius of the reactor. A plot of the experimental data points and the ideal laminar velocity profile for one of the data sets is shown in Figure 24:

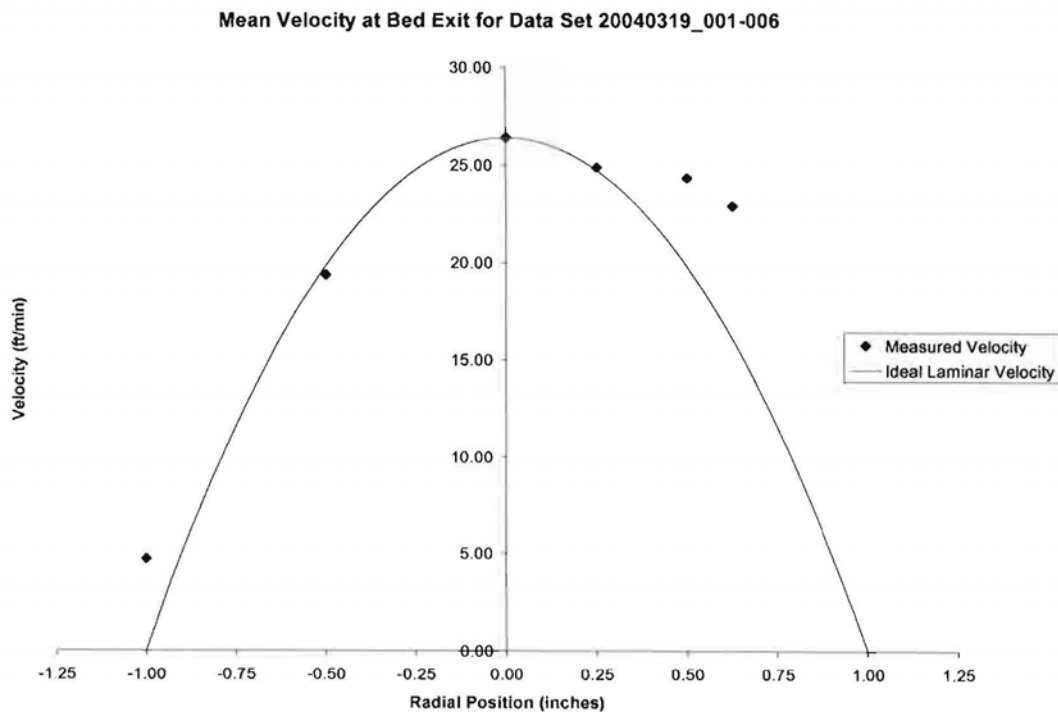

*Figure 24:* Plot of velocity profile at reactor exit

In the plot above, it is clear that some of the experimentally measured data points agree with the ideal velocity profile, and some do not. One reason for the non-agreement could stem from the fact that the measurements were taken a short distance downstream of where the air enters the reactor. It is common practice to take measurement points at least 10 pipe diameters downstream of an entrance, pipe, obstruction, etc. that affects the fluid flow. Unfortunately, since the reactor used in this study is quite short, the luxury of measuring 10 pipe diameters downstream was not available. Hence, it is possible that eddies were forming inside the reactor and causing the airflow to be turbulent, instead of laminar. Furthermore, the presence of the particles likely caused the flow to be turbulent, which could have resulted in the formation of eddies. In light of these arguments, there is little reason to think that the velocity profile in the reactor charged with particles would be laminar in nature. On a similar note, the measured velocity at the different radial positions is highly variable, as shown in Figure 25 for the standard deviation of velocity:

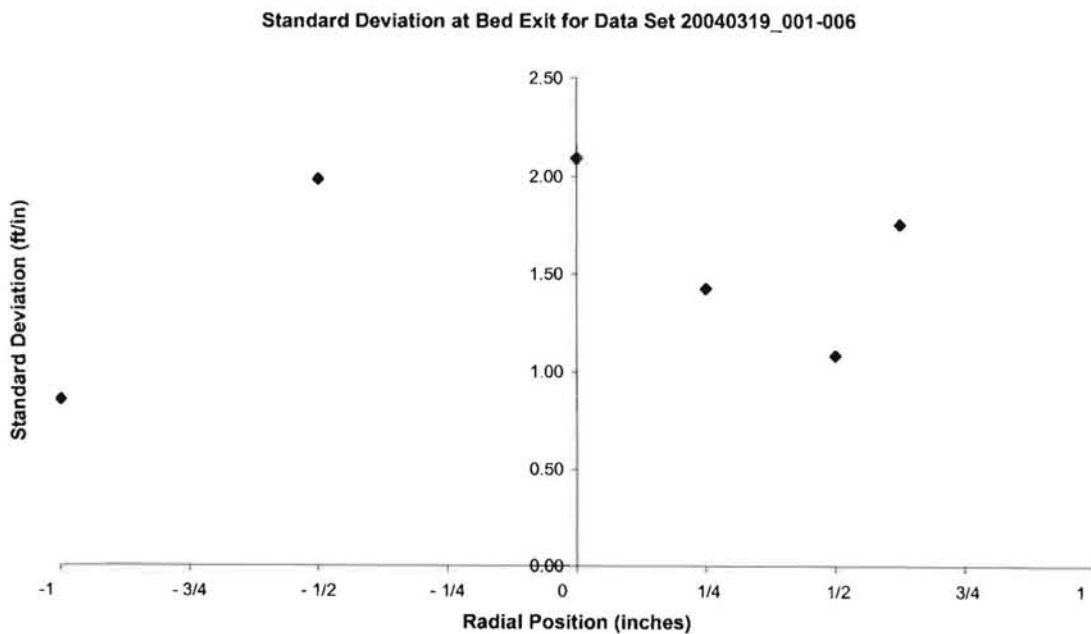

*Figure 25:* Plot of standard deviation of velocity at reactor exit

Moreover, the variability at one specific radial point can be seen in the velocity time series, as shown in Figure 26:

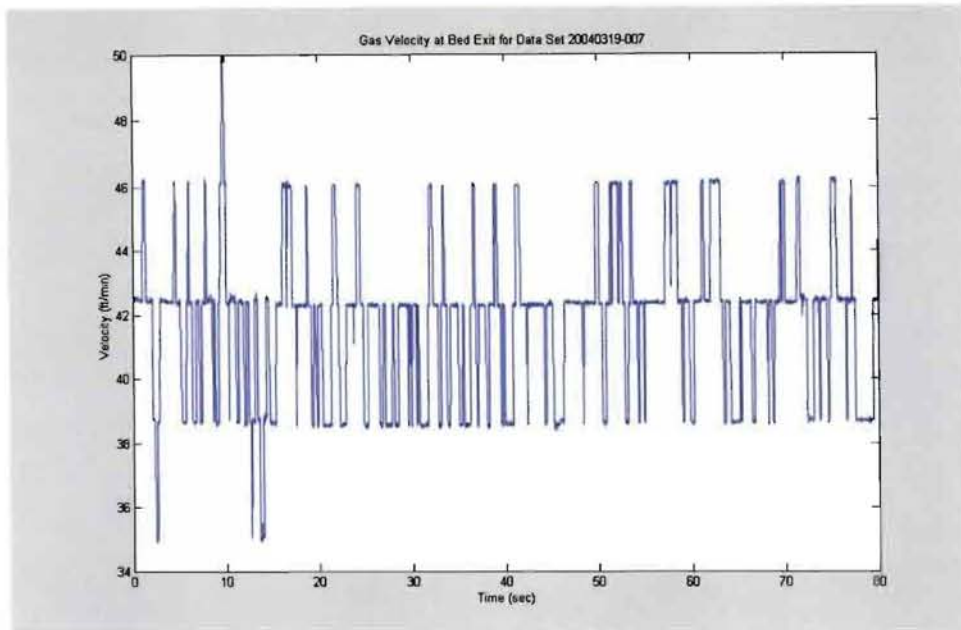
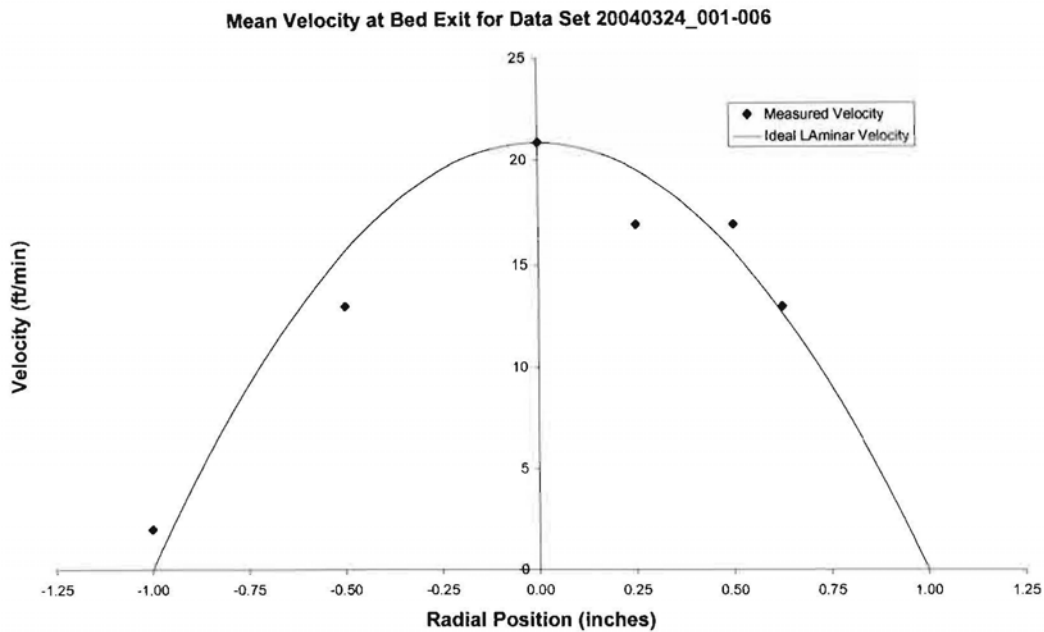

*Figure 26:* Plot of velocity time series at reactor exit

This particular velocity times series plot is from a different data set than the velocity profile and standard deviation plots above, but it is characteristic of all the velocity measurements that were taken at the exit of the reactor when it was charged with particles.

Since the results of the velocity measurements at the reactor exit raised additional questions, specifically regarding the effect of not measuring at least 10 pipe diameters downstream of the entrance, another set of experiments was conducted. This time, a 2” inch inner diameter straight PVC pipe (i.e., the same ID as the reactor) was used, and the same experiments were performed on the pipe as were performed on the reactor. The straight pipe was six feet long, and the velocity measurements were taken 5 feet downstream of the entrance—well above the 10 pipe diameter minimum. The idea was to see if the velocity profiles agreed more with the ideal laminar profile than they did in the reactor. In theory, there should be better agreement than for the reactor, because the airflow eddies have time to settle out long before the point where the velocity is measured. A plot of the mean velocity at the various radial positions in the straight pipe is shown in Figure 27:

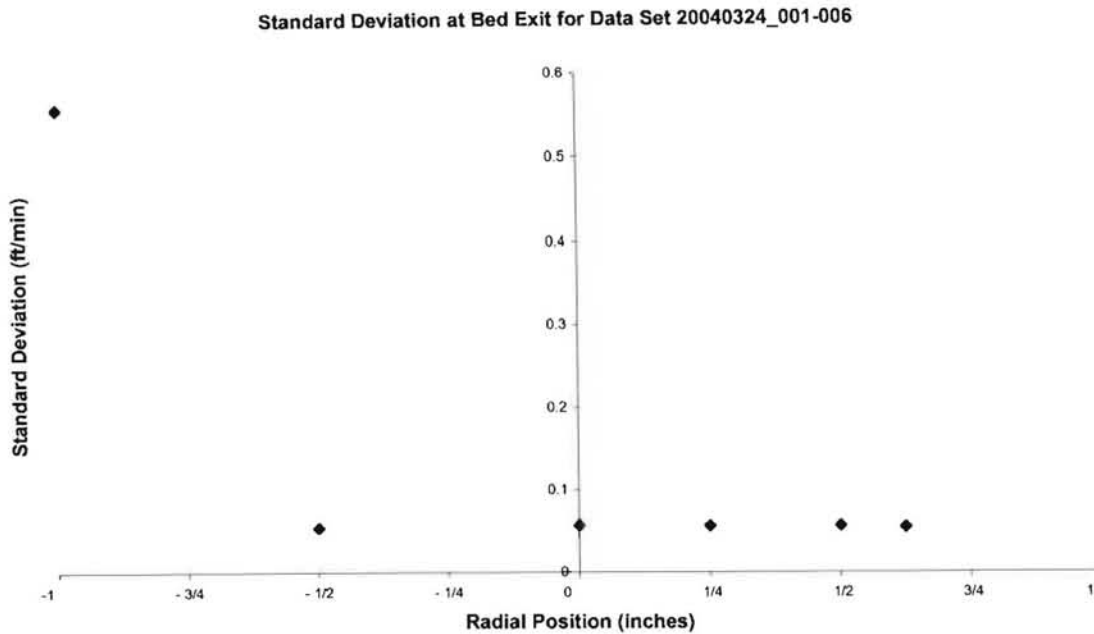



*Figure 27:* Plot of velocity profile in straight pipe

From the above plot, it is clear that the experimental data from the straight pipe is in no better agreement with the ideal laminar velocity profile than the data from the reactor. Obviously, some other effect is going on. Perhaps, the velocity anemometer itself is causing an airflow disturbance as it protrudes out into the middle of the pipe. If this is the case, then a less obtrusive type of velocity measurement device should be used.

The variability of the velocity measurements in the straight pipe, however, is much less than for the reactor. Plots of the standard deviation of the velocity for the above data set and of a velocity time series at one particular radial position are shown in Figure 28 and 29:



*Figure 28:* Plot of standard deviation of velocity in straight pipe

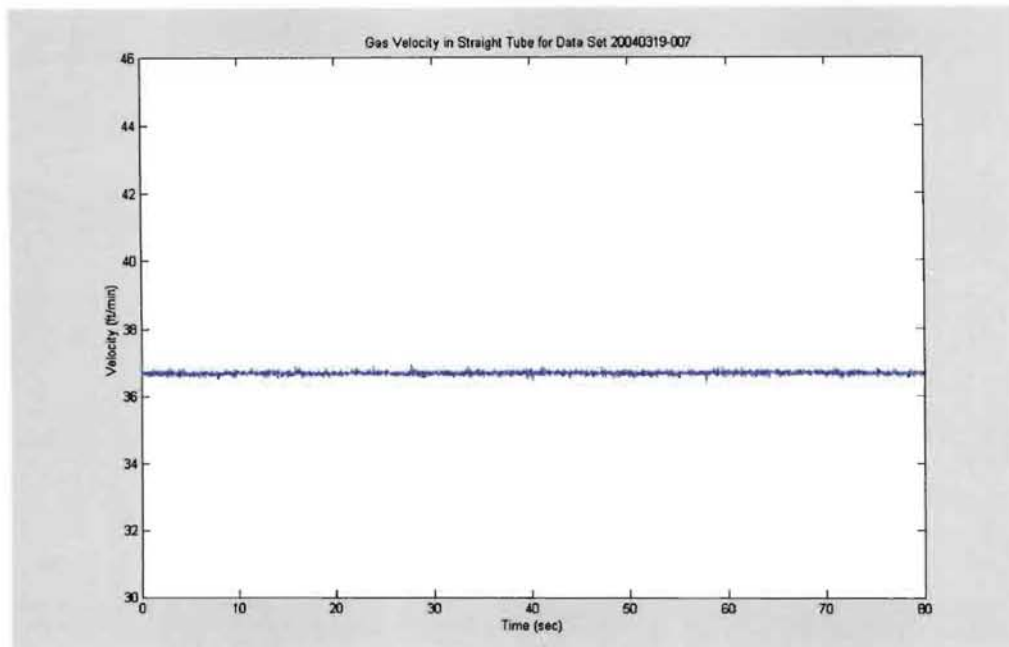

*Figure 29:* Plot of velocity time series in straight pipe

Notice that the standard deviation values of the velocity in the straight pipe range from about 0.05 to 0.55 ft/min, whereas the same values in the reactor range from about 0.75 to 2.10. Furthermore, the velocity time series signal for the straight pipe is virtually a straight line (aside from electronic noise); now, compare this to the velocity time series signal for the reactor, which

fluctuates quite dramatically. This variability difference in the two different experimental apparatuses is evidence that the airflow in the reactor is experiencing some sort of turbulent mixing behavior, and the airflow in the straight pipe is much more laminar in nature.

## **FUTURE WORK**

In the near term, further analysis of the pressure and velocity data will be performed, as well as more particle image analysis at different operating conditions. Some correlation between the particle hydrodynamics and pressure signals will hopefully be made. One immediate step along this path is to install a data acquisition board that can process streaming digital video as an input; this would allow the video to be directly stored in the computer hard drive, as opposed to storage on traditional video cassettes. Also, a faster response pressure transducer (e.g., 1000 Hz) will be acquired and used to collect even higher speed signals of the pressure oscillations in the bed of particles. At the same time, there is interest in measuring the air velocity within the bed of the particles, instead of at the reactor exit (i.e., above the particles). This poses some unique measurement challenges, and the current velocity anemometer probe may not be well suited for these experiments.

In the long term, an ozone generator and analyzer will be employed to measure the conversion of ozone through the fluidized bed reactor. This should provide an understanding of the mass transfer relationships of the particles. Also, a 1000-kW heater and thermocouples will be used to measure the response of the particles to a step change in temperature of the inlet gas stream. This should provide an understanding of the heat transfer relationships of the particles. Ideally, the results of all of these studies will be used to improve the computer simulations of fluidized bed reactors, and eventually, predictions can be made about which operating conditions are the best for uranium particle coating.

## **REFERENCES**

Fryer, Colin, Fluidized Bed Reactors Behaviour and Design, Ph.D. thesis, Department of Chemical Engineering, Monash University, Australia, February 1974.