



Spring 5-2002

Biochemical Pathways of Creatine and Creatine Phosphate

David Brock East

University of Tennessee - Knoxville

Follow this and additional works at: https://trace.tennessee.edu/utk_chanhonoproj

Recommended Citation

East, David Brock, "Biochemical Pathways of Creatine and Creatine Phosphate" (2002). *University of Tennessee Honors Thesis Projects*.
https://trace.tennessee.edu/utk_chanhonoproj/536

This is brought to you for free and open access by the University of Tennessee Honors Program at Trace: Tennessee Research and Creative Exchange. It has been accepted for inclusion in University of Tennessee Honors Thesis Projects by an authorized administrator of Trace: Tennessee Research and Creative Exchange. For more information, please contact trace@utk.edu.

UNIVERSITY HONORS PROGRAM

SENIOR PROJECT - APPROVAL

Name: David Brock East

College: Arts + Sciences Department: BCMB

Faculty Mentor: Dr. MacCabe

PROJECT TITLE: _____

Biochemical Pathways of Creatine
and Creatine Phosphate

I have reviewed this completed senior honors thesis with this student and certify that it is a project commensurate with honors level undergraduate research in this field.

Signed: Jeff MacCabe, Faculty Mentor

Date: 5/2/02

Comments (Optional):

Biochemical Pathways of Creatine and Creatine Phosphate

By: David Brock East

Senior Honors Paper

Introduction

For whatever the purpose of exercise, be it improved health, appearance, or sport performance, success is determined primarily by two major factors: genetics and training. Genetics are obviously set once a person is born, but training is an area that can be manipulated to optimize genetic potential. However, some athletes wish to go beyond training to obtain a competitive edge. This competitive edge may sometimes be obtained through the use of ergogenic aids. Ergogenic aids are substances designed to enhance physical power, mental strength, or give a mechanical edge. A mechanical edge may represent the biomechanical ability to use energy efficiently, or to reduce the physiological energy costs to produce a given amount of power. The current hottest-selling dietary supplement (ergogenic aid) marketed to sport and exercise enthusiasts is creatine, a nutrient found in various foods.

Creatine (Cr) was discovered in 1832 by a French scientist, Michel Eugene Chevreul, who extracted it from meat. Justus von Liebig (1847) also confirmed Chevreul's discovery as a regular constituent in meat with higher concentrations of creatine in wild animals as compared to captive. Phosphocreatine (PCr) was discovered in 1927 with observations that it was involved in exercise energy expenditure. With the discovery of the muscle biopsy in 1968, scientists were able to extract muscle tissue and examine the role of PCr. Today nuclear magnetic resonance (NMRs) techniques are used to study creatine and its role in muscle tissue. During exploratory medical research during the 1970's and 1980's, evidence began to show that creatine might be an effective ergogenic aid. Sipila et al. (1981) while investigating the effect of prolonged creatine supplementation on gyrate atrophy of the choroids and retina within the eye, an

autosomal-recessive disease often accompanied by clinical findings of mild progressive atrophy of the type II skeletal muscle fibers. Some patients however reported a subjective impression of increased strength during treatment and one active runner lowered his former record in the 100m dash from 17 seconds to 15 seconds.

Two Olympic champions in the 1992 Barcelona Summer Olympics, Linford Christie in the men's 100m dash and Sally Gunnell in the women's 400m hurdles reportedly trained with creatine prior to the Games. Creatine supplementation was also used by the Cambridge University rowing team three months before they defeated the heavily favored Oxford University. Since 1992, creatine supplementation has been exponentially growing. A researcher at Penn State University estimated that approximately 80% of the athletes at the 1996 Olympic Games were using or had used creatine as a ergogenic aid. Many celebrated athletes have admitted to creatine supplementation including Mark McGwire who held the single season home run record until this year. According to Rob Zatchetka, New York Giants Offensive Lineman and Rhodes Scholar with a degree in Biochemistry, "There's no magic bullet out there. But creatine is about the closest thing" (Strauss and Mihoces 1998).

Creatine supplementation has grown within college athletics as well as college students. A recent survey of colleges across the country indicated that creatine was "most helpful" in athletic training and performance. U.S. Navy Seals have listed creatine among their top five most commonly used supplements to increase muscle mass, strength, and power. Manufacturing of creatine has increased tremendously throughout the past ten years with an estimated \$100 million per year in sales (SKW Trostberg 1998).

What Creatine is...

Creatine (methyl guanidine-acetic acid), a nitrogenous amine, is a naturally occurring constituent found in food. Creatine is not an essential nutrient because it can be produced by an endogenous synthesis within the body. Creatine is found primarily in vertebrates, primarily participating in metabolic reactions within the cells and eventually being catabolized in the muscle to creatinine and excreted by the kidneys. The typical average-size adult (70kg) would contain approximately 120g of total Creatine. The turnover rate is typically 1.6% per day (Balsom et al. 1995). While the typical requirement of new creatine (either taken in from food or supplementation or synthesized endogenously) is about 2g per day for a 70kg individual.

Dietary sources of creatine include red meat and fish. Three to five grams of creatine per kilogram of fish or red meat is typical. Plants offer basically no creatine based on findings of Balsom et al (1995). Therefore vegetarians really entirely on the endogenous synthesis of the body to obtain proper creatine levels.

The intestinal uptake of creatine from dietary sources is absorbed intact from the intestinal lumen despite the presence of highly acidic gastrointestinal secretions during the digestive process and then enters the bloodstream (Clark 1996). Plasma creatine is then delivered to the various body tissues (heart, smooth muscles, brain, and testes) with the large majority (approx. 95%) going to the skeletal muscles. The cellular concentration of creatine is determined by the cell's ability to assimilate creatine from the plasma because there is no muscle synthesis (Clark 1996). Two mechanisms have been proposed to explain the very high creatine concentration within skeletal muscle. The first

involves the transport of creatine into muscle by a specific sodium-dependent entry process, and the second entails the trapping of creatine within the muscle.

Studies (Greenhaff 1997, Radda 1996) have demonstrated that creatine entry into muscle occurs actively against a concentration gradient, possibly involving creatine interacting with a specific membrane site that recognizes part of the creatine molecule. The total creatine content of muscle cells is controlled by an active creatine uptake in which beta-2-receptor stimulation and the activity of sodium-potassium adenosine-triphosphatase (ATPase) play a significant role. Creatine is actively transported into tissues by a sodium-dependent transporter which is highly specific for creatine.

Studies of Haughland and Chang (1975) indicate that creatine is more readily uptaken by cells when taken with insulin. Studies on rats which were given highly concentrated carbohydrate and creatine diets ingested a higher amount of total creatine than rats ingesting creatine alone or with other food sources.

Muscle creatine content is relatively stable because once extracellular creatine is sequestered into the cytosol, it becomes rapidly phosphorylated by creatine kinase. Approximately 60-70% of total muscle creatine exists in the form of phosphocreatine (PCr) that is unable to pass back through the membrane of the cell. The free creatine (nonphosphorylated) may also bind to intercellular components that may facilitate further cell retention on top of phosphorylated creatine (Williams et al 1999).

Creatine is also an osmotically active substance, thus an increase in intracellular creatine concentration may likely induce the influx of water into the cell. This is an important consideration in relation to body mass as well as possible health concerns as will be discussed later.

Creatine from dietary sources usually accounts for about half of the daily body requirements depending on the amount of fish, red meat, and supplementation one may receive. The remaining amount is produced endogenously. This creatine synthesis occurs from the amino acids glycine, arginine, and methionine. The entire glycine molecule is incorporated into creatine whereas arginine furnishes its amidino group and methionine its methyl group.

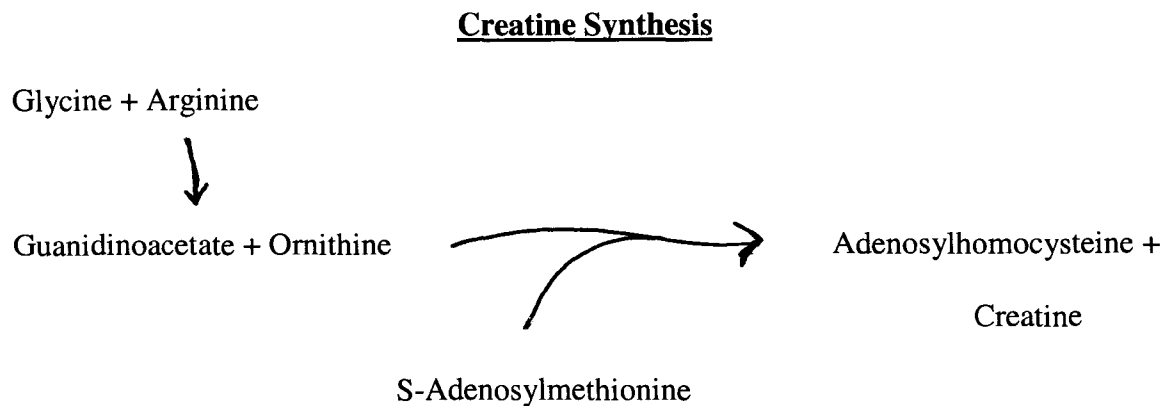

Endogenous creatine synthesis occurs primarily in the liver, but also at a small rate in the kidney and pancreas. The transfer of a methyl group from S-adenosylmethionine is the irreversible reaction (committed step) during synthesis. While arginine participates in the urea cycle, glycine is a precursor of purine nucleotides, and methionine contributes its methyl group to DNA and RNA; the endogenous synthesis of creatine does not interfere with the functions of these amino acids in their respective processes (Williams et al.1999).

Creatine biosynthesis is first regulated by dietary sources of creatine. Those whose dietary creatine intake is high will have a lower rate of endogenous synthesis.

Those with little to no dietary creatine intake (vegetarians et al.) have a much higher rate of endogenous synthesis and usually maintain creatine levels typical of a normal individual (Harris et al. 1992).

Storage of creatine varies with different muscle types. Ninety-five percent of total muscle creatine is found in skeletal muscles. Of this 95%, more creatine is found in class II fast-twitch white muscle fibers (typically responsible for anaerobic energy) while less is found in class I slow-twitch red muscle (responsible for aerobic energy). White muscle has 31% more PCr than red muscle (Clark et al. 1996).

Creatine:

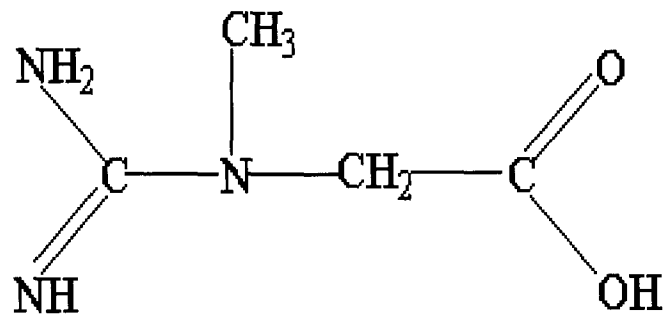

What Creatine does...

To explain the apparent ergogenic effect that creatine has had on sport training and performance, one must explore the metabolic function of creatine within cells of the body. Also worth noting are creatine's effects on the myocardium, nervous system, and in protein synthesis that all may have health or sport performance implications.

All cells use ATP as the immediate energy source. Maximal effort exercise uses ATP (adenosine triphosphate) as the primary energy source. Energy is produced when a phosphate group is cleaved from the ATP molecule by ATPase enzyme thus producing ADP (adenosine diphosphate) and Pi (inorganic phosphate) (Williams et al. 1999).



In Sahlin's studies in 1986, he indicated that ATP stores of energy are limited. At very high intensities, the ATP available to a cell would only last one or two seconds. But although cellular ATP stores are limited, they may be regenerated by other metabolic processes in the cells, including anaerobic glycolysis and oxidative metabolism. For example Sahlin determined that ATP supported by anaerobic glycolysis lasted typically seven minutes. ATP is generated more slowly by oxidative processes.

During maximal intensity exercise, the phosphorylated form of creatine is used by creatine kinase to cleave off the phosphate for resynthesis of ATP.

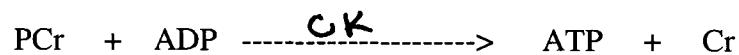

The energy derived from the degradation of PCr allows the ATP pool to be turned over several dozen times during an all-out maximal-effort exercise. Sahlin calculates that PCr stores contain 0.34mol ATP, produce 8.6mmol ATP/kg dm, and support very high exercise intensities that are reported to last no more than about 30sec. PCr may be the

major fueling source of exercise up to 10 seconds. Greenhaff (1997) indicates that PCr utilization may decline with time as other forms of resynthesizing ATP begin to take over. The following data involves ATP(mmol ATP/sec/kg dm) provision from PCr.

0-1.3 sec = 9.0
0-2.6 sec = 7.5
0-5.0 secs = 5.3
0-10 sec = 4.2
0-20 sec = 2.2

With three to four times as much PCr as ATP, phosphocreatine is a good refueling source for resynthesizing ADP to ATP. But just as with ATP, there is a limit on how much PCr is available within a cell. In order to replenish the PCr used during exercise, the enzyme creatine kinase needs to be understood.

Creatine kinase (CK) enables the cell to increase the capacity factor without diminishing the intensity factor. Creatine kinase is highly concentrated in muscle and nerve tissues in order to handle high metabolic fluxes during periods of increased energy utilization and generation. The reaction is driven to the right with the removal of ATP and to the left by the removal of ADP. Creatine kinase exists in various isoforms, and they function simultaneously to form a rapid interconversion of PCr and ATP. Creatine kinase is composed of two subunit types, M (muscle) and B (brain) isoenzymes, giving three isoenzyme combinations (MM – MB – BB). In addition a fourth (Mi-CK) is located on the outer side of the inner mitochondrial membrane (Clark 1996).

Of interest here are the MM-CK and Mi-CK isoforms which are found in the muscle tissue. Skeletal muscle is the tissue with the greatest CK activity, and the skeletal muscle CK exists almost 100% in MM-CK form. Fast twitch muscle has a larger quantity of MM-CK than does slow twitch. MM-CK is found on the myofibrils and

localized to the A-bands. It generates ATP from ADP. Mi-CK is functionally coupled to oxidative phosphorylation because it catalyzes the phosphorylation of creatine to PCr (Clark 1996).

Looking at the maximal effort exercise, the limiting factor could be the resynthesis of PCr. Although the mechanisms are not totally understood, a creatine phosphate shuttle has been proposed in sustaining high-energy demands (Newsholme and Beis 1996). Using this concept, PCr and creatine act as shuttle molecules between the sites of ATP production and hydrolysis. One proposed shuttle may be coupled to glycolysis (van Dijsen et al. 1993), and others believe that the rapid resynthesis of PCr is likely to be oxidative in origin (Clark 1996). Mi-CK promotes the formation of PCr from creatine and from ATP formed by way of oxidative metabolism in the mitochondria (Ma et al. 1996). Phosphocreatine is thought to diffuse from the mitochondria to the myofibrillar M-band, where it locally serves to replenish ATP with MM-CK as catalyzing agent. Then creatine diffuses back to the mitochondria where it can be rephosphorylated and sent back through the shuttle.

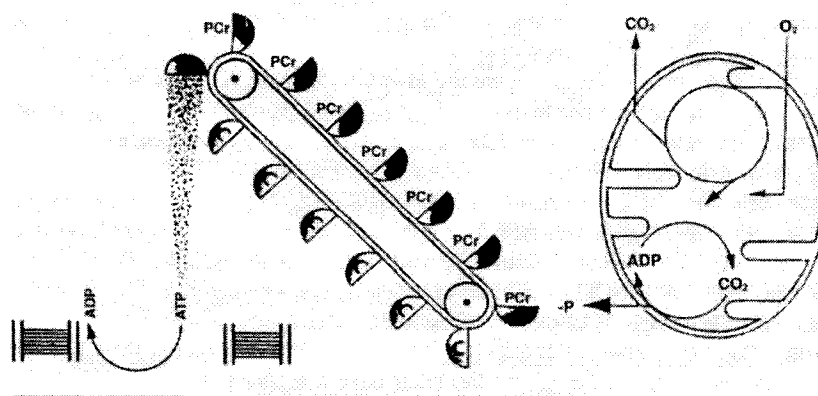

The picture shows that PCr and creatine serve as auxiliary energy messengers between the mitochondria and the cytosolic sites of ATP utilization (Ma 1996). At the mitochondrial site, newly synthesized ATP enters the intermembrane space, where a portion is utilized by Mi-CK for the formation of PCr. The resulting ADP is then favorably situated for transport by translocase into the mitochondrial matrix in exchange for matrix ATP. The PCr formed, unlike ATP, does not compete with ADP for transport by translocase. In muscle cells, PCr diffuses to the myofibrils where its small sized permits rapid penetration between the myofilaments to reach the CK isozyme located at the M line. There PCr regenerates ATP from the ADP formed during contraction (Williams et al.1999).

Creatine may also help to buffer the following reaction:



This buffer may be very important in cellular function. One of the primary functions of the phosphagen system may be buffering elevations of ADP rather than simply resynthesizing ATP. Elevations in ADP have been reported to have an inhibitory effect on some ATP reactions. Most cellular ATPases utilize ATP and thus shift the balance of ADP/ATP within a cell. This alter in equilibrium kinetics may effect myosin ATPase, sarcoplasmic reticulum kinetics around the cellular ATPase, or other regulatory ATPases possibly slowing muscle filament cross-bridge cycling (Clark 1996).

Mujika and Padilla (1997) reported ATP hydrolysis rate exceeding the ADP rephosphorylation rate through oxidative processes, anaerobic glycolysis, or PCr

breakdown, ATP is resynthesized via the myokinase reaction. This results in the formation of AMP which is deaminated by the purine nucleotide cycle, which leads to the depletion of the adenine nucleotide pool and the eventual production of ammonia and hypoxanthine.

With an increase in the capacity of the creatine phosphate shuttle, very high intensity exercise performance might be improved. At the sarcomeres, the immediate rephosphorylation of ADP by MM-CK maintains a lower ADP concentration. This prevents the inactivation of myosin ATPases and loss of adenine nucleotides (van Deursen et al. 1993).

Creatine may also help buffer the H⁺ ions from lactic acid. Both ATP hydrolysis and the concurrent function of the calcium and sodium pumps release protons. During resynthesis of ATP (PCr dependent), protons are taken up. Reports have suggested that these H⁺ ions and the resulting decrease in pH within a cell which contribute to fatigue. Thus increasing the cells ability for buffering H⁺ may decline pH and delay the onset of fatigue (Williams et al. 1999).

Tissue oxygen uptake (VO₂) is now thought to change in parallel with changes in creatine content (Saks 1996). These reports are showing that CK might serve as a rate-limiting enzyme in tissue oxygen uptake. Changes in concentrations of creatine and may control cellular metabolic activity to a greater degree than alterations in the concentrations of ATP, ADP, and Pi. Ma et al. in 1996 hypothesized that creatine produced at sites of high metabolic activity, as it diffuses back into the mitochondria to be rephosphorylated to PCr through the action of Mi-CK, may be the respiratory signal to the mitochondria. Supporters of this theory state that it provides a viable explanation as

to the relationship between oxygen uptake kinetics and changes in Cr/PCr ratio. If this is true, increasing Cr and PCr levels through supplementation may have a greater ergogenic effect than originally thought.

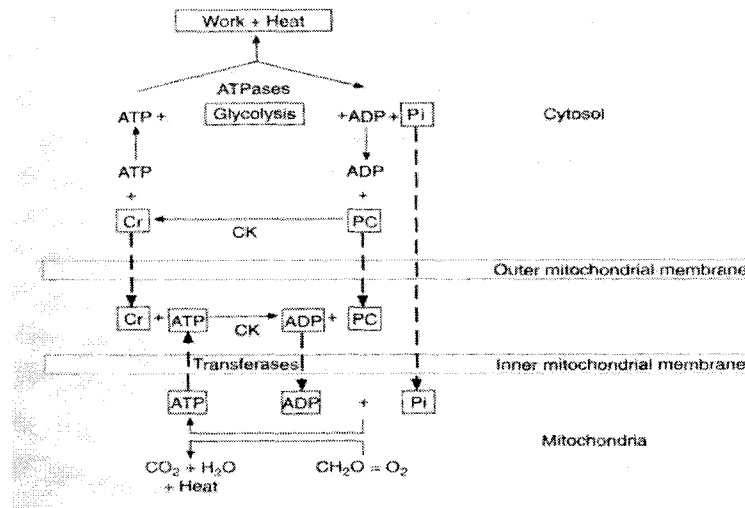

Though the majority of creatine in the body is found in the skeletal muscles, a small percentage of creatine is found in the heart and brain. Over the last decade, much research has involved creatine and its function(s) on myocardial metabolism (Saks 1996). So much research has been done not only because of the effects of PCr metabolically on the heart but also because reduced creatine availability has been associated with heart failure, ischemia, increased prevalence of ventricular arrhythmias, and instability of myocardial cell membranes during ischemia. As a result, intravenously administered PCr and oral creatine have been proposed as cardio protective agents for people with ischemic heart disease.

Small amounts of creatine have also been found in the central and peripheral nervous system tissues. Evidence suggests that creatine may play an important role in

brain function as well as in neuromuscular control. For example, infants born with the inability to synthesize creatine endogenously experience abnormal mental, neuromuscular, and physical maturation (Stockler 1997). Oral creatine supplementation in infants with inborn errors in creatine synthesis has been found to promote normal mental and physical development. This same oral creatine supplementation has also been used to treat selected neuromuscular diseases such as mitochondrial cytopathies.

Creatine is now being researched because some studies have shown that supplementation may promote new protein synthesis. Adding creatine to incubated skeletal muscle cells enhanced myosin synthesis in vitro. This may happen by promoting intracellular fluid retention and cellular osmotic pressure (Kreider et al. 1998).

After changing creatine to PCr, there is only one known other configuration that creatine can form. In vertebrates this is the nonenzymatic irreversible reaction to form creatinine. Measurements done on rat skeletal muscle have shown that regular cellular creatine loss is approximately 1.7% to 2.3% of total creatine content per day. In humans the creatinine is excreted in the urine and has been found to average approximately the same percentage. According to Clark, the conversion to creatinine seems to be spontaneous. Creatinine loss has in some studies been seen to increase with increases in high-demand exercise.

Who and When Creatine helps...

Over the past decade scientists have been studying exercise and sport performance and how it relates to muscles. With the discovery of the muscle biopsy technique, scientists were able to extract a piece of living muscle tissue and study it thoroughly. Currently, research is being done exploring different types of muscles in the body. First are the oxidative muscle fibers (type I and II red) which store substantial amounts of glycogen. This slow twitch muscle type was found in athletes that trained for aerobic events such as marathons and other distance sports. The primary source for energy in these types of events comes from carbohydrates and aerobic glycolysis. Thus a program of carbohydrate loading is a common practice among distance runners before an event.

Sports primarily dependent on high anaerobic capacity typically have an abundance of type II white muscle fibers. These sports are usually high-power short term events such as short sprints or weightlifting-type sports. These type II fibers are rich in phosphocreatine and are designed to produce very high intensity anaerobic power. During the early 1990's, research associates from England and Sweden initiated contemporary research to investigate the ergogenic potential of creatine supplementation using techniques similar to that of the carbohydrate loading (Williams et al. 1999).

The mechanism for fatigue is still not fully understood but the classic hypothesis is that fatigue is caused by failure of the energetic processes to generate adenosine triphosphate at a sufficient rate for exercise demand. Sahlin(1998) finds that interventions increasing the power or capacity of the energetic processes result in

enhanced performance and a delayed onset of fatigue. Factors that impair the energetic processes would naturally have a negative influence on performance.

Strength training and/or resistance training can also help when fighting fatigue. Substrate availability may also affect fatigue. Sahlin (1998) states that the amount of energy possibly produced from PCr is limited by the intramuscular store. Results have shown that high anaerobic demands on muscles can decrease the PCr concentrations in muscles. Along with this, results also indicated that during short lasting maximal exercise, anaerobic utilization of muscle PCr and glycogen will fuel muscle contraction; evidence suggests that fatigue here is related to the inability of type II muscle fiber PCr stores to maintain the high rate of resynthesis the exercise demands. Tests showed that individuals with a higher PCr content within their white muscle fibers had the smallest decline in power during high intensity short-term exercise.

Creatine as discussed earlier has shown to have possible ergogenic effects on mainly short-term high-energy exercise. But creatine may also have an effect on longer-term exercise, and therefore creatine may offer a great number of ergogenic benefits to those training with the nutrient. Creatine supplementation has been shown to increase a typical level of total creatine content within a cell from 120mmol/kg to approximately 150mmol/kg. Some of these potential ergogenic benefits may include increasing phosphocreatine availability, increasing phosphocreatine resynthesis, reducing muscle acidity, affects on oxidative metabolism, enhancing training, and also an increased body mass.

Sahlin (1998) found that when a person ran the 100m dash his speed decreased before finishing although his total PCr concentration had not been totally depleted. From

this he concluded that PCr was limited by contractile proteins or motor unit recruitment. This went along with many other research whose results led to the belief that PCr availability was an important but not the only limiting factor in exercise. But with these results, creatine supplementation began to be explored to possibly increase the TCr thus increasing the total PCr available to a cell. Some findings (Casey et al. 1996) have shown that oral creatine supplementation attenuates ATP degradation during intense muscle contraction by as much as 30%. Similar studies have shown PCr to act as a temporal buffer of cytosolic ADP accumulation during exercise. Mujika and Padilla (1997) believe that an increased muscle PCr concentration achieved through supplementation would most likely induce an enhanced rephosphorylation of ADP during muscular exercise, resulting in a lesser adenine nucleotide degradation, or preservation of ATP. This ergogenic effect would be best seen in a short distance sprint running or swimming.

Bogdanis et al. (1995) reported PCr resynthesis during recovery from maximal short term high energy exercise to be a determining factor in restoration of energy for a subsequent high-intensity exercise task. These studies focused on the availability of creatine within a cell to be resynthesized to PCr by CK. Studies suggested that an increased level of total creatine within a cell would allow faster phosphocreatine resynthesis. Therefore, supplementally raising the level of creatine in the body may delay fatigue because the creatine is able to be resynthesized and sent back to the sites of ATP usage quicker.

Clark (1996) noted that the rapid resynthesis is likely to be oxidative in origin as it reacts with Mi-CK that is coupled to oxidative phosphorylation. With this

understood, it would be reasonable to associate higher levels of creatine to a higher rate of oxidative phosphorylation. But this is still more a hypothesis than a fact. But benefits from the ergogenic effects here may include basketball and tennis where short bursts of energy are needed over and over.

Anaerobic glycolysis increases lactic acid accumulation, with increased H^+ (hydrogen) ion concentration a possible contributor to muscle fatigue. PCr acts as the principle metabolic buffer in muscle, accounting for approximately 30% of the total muscle buffer capacity (Sahlin 1998). While ADP and PCr resynthesize into ATP, a H^+ ion is picked up during the reaction. Therefore the utilization of PCr buffers H^+ . According to Rossiter et al (1996), a benefit of an elevated buffer level is that it would allow the muscle to accumulate more lactic acid before reaching a limiting muscle pH, and thus allow more high-intensity exercise to be performed. Blood lactate levels, if lowered, might be indicative of less reliance on anaerobic glycolysis for a standardized exercise bout. Some researchers have found lowered levels following creatine supplementation, while many studies have not. However, if greater work output is gained through creatine supplementation, the lack of significant differences in lactate could be seen as less reliance on anaerobic glycolysis. Such activities as downhill skiing, rowing, and longer aerobic events would gain most from this ergogenic effect of creatine supplementation.

Typically PCr is coupled with anaerobic metabolic processes, but some researchers have begun to think that creatine supplementation, by increasing PCr in cells, may modify substrate utilization and possibly improve performance during prolonged sub-maximal exercise (Brannon et al. 1997). Using an animal, data reported that creatine

supplementation, in combination with training, increased the level of citrate synthase activity. Citrate synthase is a marker of oxidative capacity in skeletal muscle. Creatine supplementation alone caused an increase similar to above in the soleus while it had no effect on the plantaris (although training did). Though no sure answer has been found, the investigators feel that the effect may have been attributed to the role of creatine in the transport of ATP between the cytosol and the mitochondria (respiratory signal to the mitochondria).

Engelhardt et al. (1998) note that aerobic endurance athletes have to use anaerobic work to only a certain extent but this type of work may influence their performance in certain areas (i.e. A marathoner sprinting the last hundred yards). Bangsbo (1994) noted that aerobic energy was approximately 90% of soccer, the anaerobic energy needed when sprinting or jumping where ATP and PCr are used is very important.

Greenhaff (1997) found that creatine supplementation benefited athletes over the long term. This happened from an individual's raised levels of creatine and PCr enabling a higher training load. Not only this, but also high creatine and PCr levels can improve repetitive interval sprint capacity, reduce training fatigue, and accelerate muscle hypertrophy.

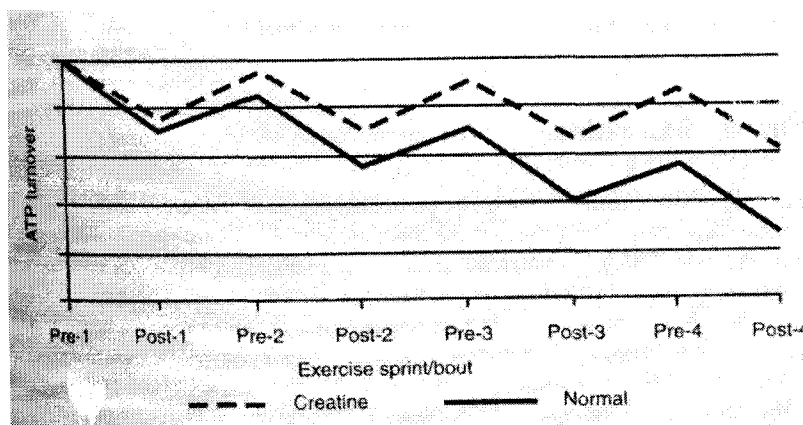

The picture shows that PCr and creatine serve as auxiliary energy messengers between the mitochondria and the cytosolic sites of ATP utilization (Ma 1996). At the mitochondrial site, newly synthesized ATP enters the intermembrane space, where a portion is utilized by Mi-CK for the formation of PCr. The resulting ADP is then favorably situated for transport by translocase into the mitochondrial matrix in exchange for matrix ATP. The PCr formed, unlike ATP, does not compete with ADP for transport by translocase. In muscle cells, PCr diffuses to the myofibrils where its small sized permits rapid penetration between the myofilaments to reach the CK isozyme located at the M line. There PCr regenerates ATP from the ADP formed during contraction (Williams et al.1999).

Creatine may also help to buffer the following reaction:

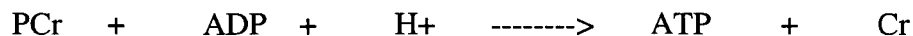

This buffer may be very important in cellular function. One of the primary functions of the phosphagen system may be buffering elevations of ADP rather than simply resynthesizing ATP. Elevations in ADP have been reported to have an inhibitory effect on some ATP reactions. Most cellular ATPases utilize ATP and thus shift the balance of ADP/ATP within a cell. This alter in equilibrium kinetics may effect myosin ATPase, sarcoplasmic reticulum kinetics around the cellular ATPase, or other regulatory ATPases possibly slowing muscle filament cross-bridge cycling (Clark 1996).

Mujika and Padilla (1997) reported ATP hydrolysis rate exceeding the ADP rephosphorylation rate through oxidative processes, anaerobic glycolysis, or PCr

breakdown, ATP is resynthesized via the myokinase reaction. This results in the formation of AMP which is deaminated by the purine nucleotide cycle, which leads to the depletion of the adenine nucleotide pool and the eventual production of ammonia and hypoxanthine.

With an increase in the capacity of the creatine phosphate shuttle, very high intensity exercise performance might be improved. At the sarcomeres, the immediate rephosphorylation of ADP by MM-CK maintains a lower ADP concentration. This prevents the inactivation of myosin ATPases and loss of adenine nucleotides (van Deursen et al. 1993).

Creatine may also help buffer the H⁺ ions from lactic acid. Both ATP hydrolysis and the concurrent function of the calcium and sodium pumps release protons. During resynthesis of ATP (PCr dependent), protons are taken up. Reports have suggested that these H⁺ ions and the resulting decrease in pH within a cell which contribute to fatigue. Thus increasing the cells ability for buffering H⁺ may decline pH and delay the onset of fatigue (Williams et al. 1999).

Tissue oxygen uptake (VO₂) is now thought to change in parallel with changes in creatine content (Saks 1996). These reports are showing that CK might serve as a rate-limiting enzyme in tissue oxygen uptake. Changes in concentrations of creatine and may control cellular metabolic activity to a greater degree than alterations in the concentrations of ATP, ADP, and Pi. Ma et al. in 1996 hypothesized that creatine produced at sites of high metabolic activity, as it diffuses back into the mitochondria to be rephosphorylated to PCr through the action of Mi-CK, may be the respiratory signal to the mitochondria. Supporters of this theory state that it provides a viable explanation as

to the relationship between oxygen uptake kinetics and changes in Cr/PCr ratio. If this is true, increasing Cr and PCr levels through supplementation may have a greater ergogenic effect than originally thought.

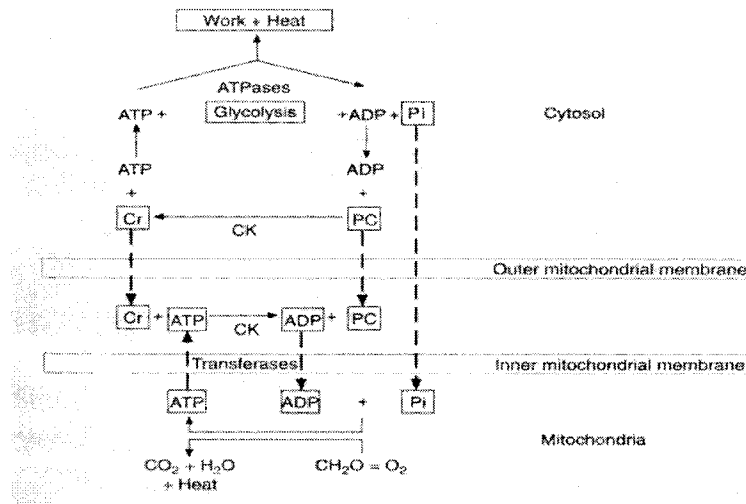

Though the majority of creatine in the body is found in the skeletal muscles, a small percentage of creatine is found in the heart and brain. Over the last decade, much research has involved creatine and its function(s) on myocardial metabolism (Saks 1996). So much research has been done not only because of the effects of PCr metabolically on the heart but also because reduced creatine availability has been associated with heart failure, ischemia, increased prevalence of ventricular arrhythmias, and instability of myocardial cell membranes during ischemia. As a result, intravenously administered PCr and oral creatine have been proposed as cardio protective agents for people with ischemic heart disease.

Small amounts of creatine have also been found in the central and peripheral nervous system tissues. Evidence suggests that creatine may play an important role in

brain function as well as in neuromuscular control. For example, infants born with the inability to synthesize creatine endogenously experience abnormal mental, neuromuscular, and physical maturation (Stockler 1997). Oral creatine supplementation in infants with inborn errors in creatine synthesis has been found to promote normal mental and physical development. This same oral creatine supplementation has also been used to treat selected neuromuscular diseases such as mitochondrial cytopathies.

Creatine is now being researched because some studies have shown that supplementation may promote new protein synthesis. Adding creatine to incubated skeletal muscle cells enhanced myosin synthesis in vitro. This may happen by promoting intracellular fluid retention and cellular osmotic pressure (Kreider et al. 1998).

After changing creatine to PCr, there is only one known other configuration that creatine can form. In vertebrates this is the nonenzymatic irreversible reaction to form creatinine. Measurements done on rat skeletal muscle have shown that regular cellular creatine loss is approximately 1.7% to 2.3% of total creatine content per day. In humans the creatinine is excreted in the urine and has been found to average approximately the same percentage. According to Clark, the conversion to creatinine seems to be spontaneous. Creatinine loss has in some studies been seen to increase with increases in high-demand exercise.

Who and When Creatine helps...

Over the past decade scientists have been studying exercise and sport performance and how it relates to muscles. With the discovery of the muscle biopsy technique, scientists were able to extract a piece of living muscle tissue and study it thoroughly. Currently, research is being done exploring different types of muscles in the body. First are the oxidative muscle fibers (type I and II red) which store substantial amounts of glycogen. This slow twitch muscle type was found in athletes that trained for aerobic events such as marathons and other distance sports. The primary source for energy in these types of events comes from carbohydrates and aerobic glycolysis. Thus a program of carbohydrate loading is a common practice among distance runners before an event.

Sports primarily dependent on high anaerobic capacity typically have an abundance of type II white muscle fibers. These sports are usually high-power short term events such as short sprints or weightlifting-type sports. These type II fibers are rich in phosphocreatine and are designed to produce very high intensity anaerobic power. During the early 1990's, research associates from England and Sweden initiated contemporary research to investigate the ergogenic potential of creatine supplementation using techniques similar to that of the carbohydrate loading (Williams et al. 1999).

The mechanism for fatigue is still not fully understood but the classic hypothesis is that fatigue is caused by failure of the energetic processes to generate adenosine triphosphate at a sufficient rate for exercise demand. Sahlin(1998) finds that interventions increasing the power or capacity of the energetic processes result in

enhanced performance and a delayed onset of fatigue. Factors that impair the energetic processes would naturally have a negative influence on performance.

Strength training and/or resistance training can also help when fighting fatigue. Substrate availability may also affect fatigue. Sahlin (1998) states that the amount of energy possibly produced from PCr is limited by the intramuscular store. Results have shown that high anaerobic demands on muscles can decrease the PCr concentrations in muscles. Along with this, results also indicated that during short lasting maximal exercise, anaerobic utilization of muscle PCr and glycogen will fuel muscle contraction; evidence suggests that fatigue here is related to the inability of type II muscle fiber PCr stores to maintain the high rate of resynthesis the exercise demands. Tests showed that individuals with a higher PCr content within their white muscle fibers had the smallest decline in power during high intensity short-term exercise.

Creatine as discussed earlier has shown to have possible ergogenic effects on mainly short-term high-energy exercise. But creatine may also have an effect on longer-term exercise, and therefore creatine may offer a great number of ergogenic benefits to those training with the nutrient. Creatine supplementation has been shown to increase a typical level of total creatine content within a cell from 120mmol/kg to approximately 150mmol/kg. Some of these potential ergogenic benefits may include increasing phosphocreatine availability, increasing phosphocreatine resynthesis, reducing muscle acidity, affects on oxidative metabolism, enhancing training, and also an increased body mass.

Sahlin (1998) found that when a person ran the 100m dash his speed decreased before finishing although his total PCr concentration had not been totally depleted. From

this he concluded that PCr was limited by contractile proteins or motor unit recruitment. This went along with many other research whose results led to the belief that PCr availability was an important but not the only limiting factor in exercise. But with these results, creatine supplementation began to be explored to possibly increase the TCr thus increasing the total PCr available to a cell. Some findings (Casey et al. 1996) have shown that oral creatine supplementation attenuates ATP degradation during intense muscle contraction by as much as 30%. Similar studies have shown PCr to act as a temporal buffer of cytosolic ADP accumulation during exercise. Mujika and Padilla (1997) believe that an increased muscle PCr concentration achieved through supplementation would most likely induce an enhanced rephosphorylation of ADP during muscular exercise, resulting in a lesser adenine nucleotide degradation, or preservation of ATP. This ergogenic effect would be best seen in a short distance sprint running or swimming.

Bogdanis et al. (1995) reported PCr resynthesis during recovery from maximal short term high energy exercise to be a determining factor in restoration of energy for a subsequent high-intensity exercise task. These studies focused on the availability of creatine within a cell to be resynthesized to PCr by CK. Studies suggested that an increased level of total creatine within a cell would allow faster phosphocreatine resynthesis. Therefore, supplementally raising the level of creatine in the body may delay fatigue because the creatine is able to be resynthesized and sent back to the sites of ATP usage quicker.

Clark (1996) noted that the rapid resynthesis is likely to be oxidative in origin as it reacts with Mi-CK that is coupled to oxidative phosphorylation. With this

understood, it would be reasonable to associate higher levels of creatine to a higher rate of oxidative phosphorylation. But this is still more a hypothesis than a fact. But benefits from the ergogenic effects here may include basketball and tennis where short bursts of energy are needed over and over.

Anaerobic glycolysis increases lactic acid accumulation, with increased H⁺ (hydrogen) ion concentration a possible contributor to muscle fatigue. PCr acts as the principle metabolic buffer in muscle, accounting for approximately 30% of the total muscle buffer capacity (Sahlin 1998). While ADP and PCr resynthesize into ATP, a H⁺ ion is picked up during the reaction. Therefore the utilization of PCr buffers H⁺. According to Rossiter et al (1996), a benefit of an elevated buffer level is that it would allow the muscle to accumulate more lactic acid before reaching a limiting muscle pH, and thus allow more high-intensity exercise to be performed. Blood lactate levels, if lowered, might be indicative of less reliance on anaerobic glycolysis for a standardized exercise bout. Some researchers have found lowered levels following creatine supplementation, while many studies have not. However, if greater work output is gained through creatine supplementation, the lack of significant differences in lactate could be seen as less reliance on anaerobic glycolysis. Such activities as downhill skiing, rowing, and longer aerobic events would gain most from this ergogenic effect of creatine supplementation.

Typically PCr is coupled with anaerobic metabolic processes, but some researchers have begun to think that creatine supplementation, by increasing PCr in cells, may modify substrate utilization and possibly improve performance during prolonged sub-maximal exercise (Brannon et al. 1997). Using an animal, data reported that creatine

supplementation, in combination with training, increased the level of citrate synthase activity. Citrate synthase is a marker of oxidative capacity in skeletal muscle. Creatine supplementation alone caused an increase similar to above in the soleus while it had no effect on the plantaris (although training did). Though no sure answer has been found, the investigators feel that the effect may have been attributed to the role of creatine in the transport of ATP between the cytosol and the mitochondria (respiratory signal to the mitochondria).

Engelhardt et al. (1998) note that aerobic endurance athletes have to use anaerobic work to only a certain extent but this type of work may influence their performance in certain areas (i.e. A marathoner sprinting the last hundred yards). Bangsbo (1994) noted that aerobic energy was approximately 90% of soccer, the anaerobic energy needed when sprinting or jumping where ATP and PCr are used is very important.

Greenhaff (1997) found that creatine supplementation benefited athletes over the long term. This happened from an individual's raised levels of creatine and PCr enabling a higher training load. Not only this, but also high creatine and PCr levels can improve repetitive interval sprint capacity, reduce training fatigue, and accelerate muscle hypertrophy.

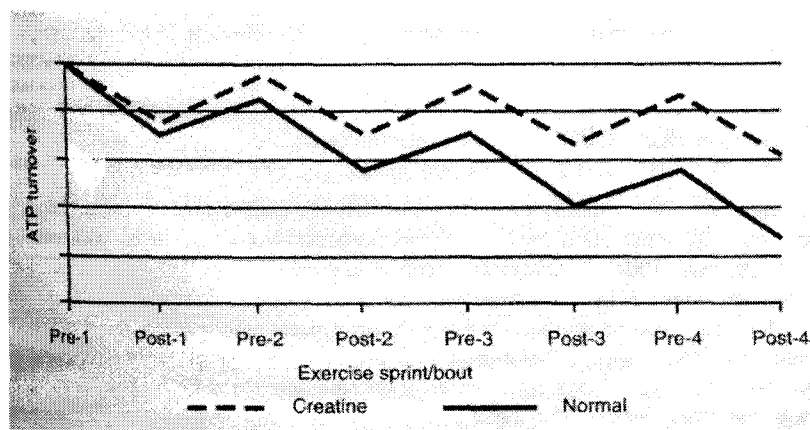

The graph from the previous page gives the typical differences in training between a person with normal levels of Cr and PCr, and an individual with an increased total creatine content. Not only is the workload more easily handled by the test subject, but also the recovery time is significantly more efficient in raising muscle creatine and ATP levels after each bout (Kreider 1997).

Creatine as discussed earlier is osmotically active and thus there is an influx of water when levels of creatine are high. With this increase in intracellular water comes an increase in total body mass. Increased mass could be beneficial to athletes who require high absolute power to overcome an external object (i.e. Offensive and Defensive Lineman). Volek et al. (1997) speculate that an increase in cellular hydration may in turn increase protein synthesis, decrease protein degradation, and thus increase fat-free mass. Volek also studied the effects of creatine supplementation on the muscle of chickens and found that creatine did increase protein synthesis. But this could not be accurate due to the low levels of creatine in chicken muscle. Although Clark (1996) concluded based on results of creatine supplementation on athletes had the same effects.

Creatine supplementation tests have shown few resulting medical problems for those involved (www.creatinefacts.com). Though less women have been involved in the studies, results are showing that there is no difference in the effects of creatine supplementation on men and women. The most common side effects of creatine supplementation have included weight gain (due to increased training and water retention), gastrointestinal distress (due to water being drawn to your intestine from the unabsorbed creatine), and kidney stress. Kidney stress is a result of loading too much creatine which is not able to be uptaken by the skeletal muscle and is thus filtered by the

kidneys. Dehydration may also occur due to the osmotic nature of creatine. Sports such as wrestling which require athletes to be strong and as light as possible could make creatine supplementation dangerous during weight-loss episodes.

Long-term consequences are thought to be little to none. But since creatine supplementation is a relatively new practice, it cannot be fully guaranteed there will be no problems. After periods of creatine supplementation however, the body is able to compensate endogenously after supplementation has ceased. However levels obtained of total creatine during supplementation periods will go back to normal after the supplementation ends. Strength will also be reduced though some gains in strength may be retained due to the increased level of exercise maintained during creatine supplementation (www.creatinefacts.com).

Overall creatine has been found to be a very important factor in not only anaerobic energy processes but also a number of other important functions within a cell. Creatine and creatine supplementation have been found to be dramatically important in training and sport performance and research will continue to further develop this new ergogenic aid for athletes.

Works Cited Page

- Bogdanis, G.C., Nevill, M.E., Boobis, L.H. 1995. Recovery of power output and muscle metabolites following 30sec of maximal sprint cycling. *Journal of Applied Physiology* 482: 467-480.
- Brannon, T.A., Adams, G.R., and Baldwin, K.M. 1997. Effects of creatine loading and training on running performance and biochemical properties of rat skeletal muscle. *Medicine and Science in Sports and Exercise* 29: 489-495.
- Casey, A., Howell, S., Hultman, E., and Greenhaff, P.L. 1996. Creatine ingestion favorably affects performance and muscle metabolism during maximal exercise in humans. *American Journal of Physiology* 271: E31-E37.
- Clark, J.F. 1996. Uses of creatine phosphate and creatine supplementation for the athlete. San Diego: Associated Press. 217-226.
- Ekblom, B., Balsom, P. 1995. Skeletal muscle metabolism during short duration high-intensity exercise: Influence of creatine supplementation. *Acta Physiologica Scandinavica* 154: 303-310.
- Engelhardt, M., Neumann, G., and Reuter, I., 1998. Creatine supplementation in endurance sports. *Medicine and Science in Sports and Exercise* 30: 1123-1129.
- Greenhaff, P.L. 1997. The nutritional biochemistry of creatine. *Journal of Nutritional Biochemistry* 11: 610-618.
- Haughland, R.B., and Chang, D.T. 1975. Insulin effects on creatine transport in skeletal muscle. *Proceedings of the Society of Experimental Biology and Medicine* 148: 1-4.

- Harris, R.C., and Hultman, E. 1992. Elevation of creatine in resting and exercised muscle of normal subjects by creatine supplementation. *Clinical Science* 83: 367-384.
- Kreider, R., Wilson, M., and Almada, A. 1997. Effects of creatine supplementation with and without glucose on body composition in trained and untrained men and women. *Journal of Strength and Conditioning Research* 11:283.
- Ma, T.M., Friedman, D.L., and Roberts, R. 1996. Creatine Phosphate shuttle pathway in tissues with dynamic energy demand. *Creatine and creatine phosphate: Scientific and clinical perspectives*. San Diego: Academic Press 17-32.
- Mujika, I., and Padilla, S. 1997. Creatine supplementation as an ergogenic aid for sports performance in highly trained athlete. *International Journal of Sports Medicine* 18: 491-496.
- Newsholme, E.A., and Beis, I. 1996. Old and new ideas on the roles of phosphagens and their kinases. *Creatine and Creatine Phosphate: Scientific and Clinical Perspectives*. San Diego: Academic Press 3-15.
- Radda, G.K. 1996. Control of energy metabolism during muscle metabolism. *Diabetes* 45: S88-S92.
- Rossiter, H.B., Cannell, E.R., and Jakeman, P.M. 1996. The effect of oral creatine supplementation on the 1000m performance of competitive rowers. *Journal of Sports Sciences* 14: 175-179.
- Sahlin, K. 1998. Anaerobic metabolism, acid-base balance, and muscle fatigue during high intensity exercise. *Textbook of Sports Medicine*. pp. 69-76. Oxford University Press.

- Saks, V.A. 1996. Cardiac energetics: Compartmentation of creatine kinase and regulation of oxidative phosphorylation. *Creatine and Creatine Phosphate: Scientific and Clinical Perspectives*. Pp 65-78. San Diego: Academic Press.
- Sipila, I. Rapola, J., and Vannas, A. 1981. Supplementary creatine as a treatment for gyrate atrophy of the choroids and retina. *Journal of Medicine* 304:867-870.
- SKW Trostberg. 1998. Memorandum. Creapure™ brand creatine products. July 15.
- Stockler, S. and Hanefeld, F. 1997. Guanidinoacetate methyltransferase deficiency: A newly recognized inborn error of creatine biosynthesis. *Pediatrics Research* 36:409-413.
- Strauss, G. and Mihoces, G. 1998. Jury still out on creatine use. *USA Today*, June 4.
- van Deursen,, J., Ruitenbeek, W., and Wieringa, B. 1993. Skeletal muscles of mice deficient in muscle creatine kinase lack burst activity. *Cell*: 74: 621-631.
- Volek, J.S. 1997. Creatine supplementation and its possible role in improving physical performance. *ACSM Health and Fitness Journal* 1:23-29.
- Williams, M.H., Kreider, R.B., and Branch, J.D. 1999. Creatine: the power supplement. Human Kinetics: Champaign IL.
- www.creatinefacts.com
- <http://www.ncbi.nlm.nih.gov/PubMed/>- used for finding Journals with appropriate topics on creatine.