



University of Tennessee, Knoxville
**TRACE: Tennessee Research and Creative
Exchange**

Field & Commercial Crops

UT Extension Publications

5-2001

PB1608 Soybean Production in Tennessee

The University of Tennessee Agricultural Extension Service

Follow this and additional works at: https://trace.tennessee.edu/utk_agexcrop



Part of the [Agronomy and Crop Sciences Commons](#)

Recommended Citation

"PB1608 Soybean Production in Tennessee," The University of Tennessee Agricultural Extension Service, PB1608-1.5M-5/01 (Rev) R12-5210-07-001-01, https://trace.tennessee.edu/utk_agexcrop/51

The publications in this collection represent the historical publishing record of the UT Agricultural Experiment Station and do not necessarily reflect current scientific knowledge or recommendations. Current information about UT Ag Research can be found at the [UT Ag Research website](#).

This Production is brought to you for free and open access by the UT Extension Publications at TRACE: Tennessee Research and Creative Exchange. It has been accepted for inclusion in Field & Commercial Crops by an authorized administrator of TRACE: Tennessee Research and Creative Exchange. For more information, please contact trace@utk.edu.

Soybean Production in Tennessee



Table of Contents

**Soybean Production
in Tennessee 4**
Wayne T. Flinchum

Soil Management 9
H. Paul Denton

**No-till Soybean
Production 11**
Wayne T. Flinchum

Soybean Weed Control 13
G. Neil Rhodes, Jr.

**Disease Management in
Soybeans Using Cultural
Practices and
Genetic Resistance 14**
Melvin A. Newman

**Soybean Insect
Management 16**
Ronnie W. Seward

**Combining Soybeans
Efficiently 19**
James B. Wills, Jr.

**Drying, Handling
and Storing 26**
*Michael J. Buschermohle
and Samuel G. McNeill*

Soybean Marketing 29
Delton C. Gerloff

Edited by:
Wayne T. Flinchum

Contributors:
Michael J. Buschermohle, Professor
*Agricultural and Biosystems Engineering
The University of Tennessee*

H. Paul Denton, Professor
*Plant & Soil Sciences
The University of Tennessee*

Charles M. Farmer, Professor Emeritus
*Agricultural Economics
The University of Tennessee*

Wayne T. Flinchum, Professor
*Plant and Soil Sciences
The University of Tennessee*

Delton C. Gerloff, Professor
*Agricultural Economics
The University of Tennessee*

Samuel G. McNeill, Assistant Professor
*Biosystems and Agricultural Engineering
University of Kentucky*

Melvin A. Newman, Professor
*Entomology & Plant Pathology
The University of Tennessee*

G. Neil Rhodes, Jr., Professor
*Plant & Soil Sciences
The University of Tennessee*

Ronnie W. Seward, former Assistant Professor
*Entomology & Plant Pathology
The University of Tennessee*

James B. Wills, Jr., Professor
*Agricultural and Biosystems Engineering
The University of Tennessee*

*This publication was funded with soybean checkoff
money from the Tennessee Soybean Promotion Council.*

Soybean Production in Tennessee

Wayne T. Flinchum, Professor
Plant and Soil Science

The soybean plant belongs to the Leguminosae family. All plants in this family are known as legumes and many have the ability to supply their own nitrogen needs. The average composition of a soybean seed is 40 percent protein, 21 percent oil, 34 percent carbohydrates and 5 percent ash on a dry matter basis. Soybeans grown in Tennessee average about 20 percent oil and 40 percent protein. Soybeans are an important crop in Tennessee and rank in the top three for cash receipts for row crops each year. Soybean acres harvested for the last five years have ranged from 950,000 to 1,150,000 acres, with an average yield of 33.9 bushels per acre.

Rotation

Growing soybeans continuously on the same land increases the possibility of diseases, insect infestation and weed interference. Rotations with corn, grain sorghum, cotton, hay or pasture can be beneficial to soybean production, as well as for the rotational crops. Rotating soybeans with a non-host crop such as corn, cotton or grain sorghum helps to reduce the effect of the soybean cyst nematode on soybean yields.

Land Selection

Soybeans can be grown in all areas of the state and on a wide range of soil types. Soybeans should be planted on moderately deep soils with adequate to high moisture supplying capacity for maximum yields. Medium-textured (silt loam) soils are better for soybean production than fine textured (silty clay loam) or coarse-textured (sandy soils). Soils should be able to supply water consistently to the soybean plant from germination through the pod-filling stage. Soybeans will produce better than corn or cotton on poorly-drained soils. Soybeans require more water per pound of dry matter than crops such as cotton or corn.

Seedbed Preparation

Good soybean stands and yields are achieved with different methods of seedbed preparation to control weeds. Seedbeds can vary from firm, well-tilled soil to those with no soil preparation. The most important factors are a seedbed free of weeds

at planting, where the seed can be placed into moist soil with good seed-soil contact.

Lime and Fertilizer

Soybean yields are best on soils that are medium high in phosphorus and high in potassium, with a pH of 6.1 to 6.5. A lime and fertilization program for soybeans should be based on the fertility level and production potential of the soil. Taking a good soil sample is the first step in a sound fertility program. Samples should be taken during the fall or early winter and sent to The University of Tennessee Soil Testing Laboratory for analysis and recommendations.

Applications of phosphate and potash are recommended for soils testing low or medium for those nutrients. However, yield increases due to direct applications of these nutrients are primarily limited to low-testing soils. Phosphate and potash can be applied in either fall or spring. When double-cropping wheat and soybeans, the recommended rate of phosphate and potash for both crops should be applied before seeding the small grain in the fall.

Lime

Soybean fields with pH levels below 6.1 should be limed for maximum production. Liming acid soil increases plant growth and yield in several ways, including (1) increased fertilizer nutrient availability and efficiency, (2) elimination of toxic levels of aluminum and manganese, (3) increased molybdenum availability, and (4) increased activity of nitrogen-fixing bacteria. Limestone recommendations are based on the initial soil pH and buffer capacity of the soil sample.

Molybdenum

Molybdenum is the only minor element normally recommended for soybean production in Tennessee. Molybdenum is recommended as a seed treatment at a rate of 0.2 ounces per bushel when soil pH is 6.4 or below. As soil pH decreases, molybdenum availability decreases. Molybdenum is recommended the first year following limestone application. The 0.2 ounce of molybdenum can be supplied by one of the following methods:

- (1) apply one-half ounce of crystalline sodium molybdate to the seed using a mechanical treater,
- (2) use one half ounce of crystalline sodium molybdate, and, if needed, the label rate of a recommended fungicide, and apply both to the seed with a mechanical treater, or
- (3) use a liquid hopper-box molybdenum source.
(Note: If the source contains a fungicide, apply according to the manufacturer's label).

Molybdenum is needed by *Rhizobium* bacteria for nitrogen fixation. Molybdenum usually increases yields of soybeans grown on acid soils, but it should not be considered as a substitute for limestone. As previously stated, liming acid soils improves growing conditions in more ways than just increased molybdenum availability.

Nitrogen

Applying nitrogen fertilizer before planting has not increased yields of soybeans when pH is 6.1 or above. The plant often responds to nitrogen fertilizer with early growth and dark green color, but yields are not increased in Tennessee. The soybean is a legume with the ability to fix atmospheric nitrogen when properly inoculated with *Rhizobium* nitrogen-fixing bacteria. Nitrogen applied at planting will delay the development of nodules.

Potash (K₂O)

Applications of potash to soybeans should be based on a current soil test. The amount of potash to apply will decrease as soil test levels increase. Soils that test high in potassium do not need ad-

ditional potash to produce high yields. Soybean yields are generally higher when potash is applied to soils testing low in potassium. Experiments have shown improved soybean seed quality and increased yields when potash is applied to low-testing soils.

Potassium uptake increases during rapid vegetative growth, then decreases as beans begin to form. Uptake is completed two to three weeks before the seed matures.

Phosphate (P₂O₅)

Soybeans use phosphorus throughout the growing season. The period of greatest demand is before pod formation and continues until about 10 days before the seeds are fully developed. Applying phosphate fertilizer on soils low in phosphorus gives soybeans a faster growth and increases yields. The main indications of a phosphorus deficiency are stunted, slender plants and low yields. Phosphorus deficiency in soybeans has not been observed in Tennessee. The application of phosphate to soybeans should be based on a current soil test. The amount of phosphate to apply will decrease as soil test levels increase. Soils that test high in phosphorus do not need additional phosphate to produce high yields.

Fertilizer and Lime Placement

Phosphate and potassium fertilizers can be applied to soybeans in a band or broadcast on top of the ground and disked into the soil for conventional seed beds. For no-till planting, broadcast lime and fertilizer on the soil surface without incorporation.

Table 1. Soil Test Levels and Recommendations

Rating	Soil Test Levels		Fertilizer Recommendations	
	Phosphorus (P)	Potassium (K)	Phosphate (P ₂ O ₅)	Potash (K ₂ O)
	————— Pounds Per Acre —————			
Low (L)	0-18	0-90	40	80
Medium (M)	19-30	91-160	20	40
High (H)	31-120	161-320	0	0
Very high (VH)	120+	320+	0	0

Properly inoculated soybeans grown in adequately limed soils do not need nitrogen fertilizer.

Seed Quality

Plant only high-quality seed known for varietal purity, high germination and mechanical purity. Soybean seed should be free of weed seeds. Soybean seed germination should be 80 percent or above. The use of certified seed will help meet all of these requirements. For maximum production, good seed that will germinate and produce a healthy, vigorous stand of soybeans in a short time is necessary. When low germination and diseased seed are used, the results are poor stand, slow growth and lower yields.

Seed treatment with a fungicide will protect the soybean seed until they germinate and will result in better stands. A fungicide should be added when planting early in cool, wet soils or when planting at a reduced seed rate.

Inoculation

Soybeans can effectively manufacture their own nitrogen if their root systems contain the correct nodule-forming bacteria, *Rhizobium japonicum*. Soils on which soybeans have been grown recently contain sufficient nodulating bacteria. If soybeans have not been grown on the land for the past three to five years, apply an inoculant to the seed just prior to planting. Store the inoculant in a cool place and treat the soybean seed just before planting. Keep the treated seed out of direct sun to prevent the bacteria from being killed. For optimum nitrogen fixation, acid soils should be limed to a pH of 6.1 to 6.5.

Planting Date

The major factors to consider when planting soybeans are soil temperature, soil moisture and

day length. Flowering is controlled by the relative lengths of the daily light and dark periods. Soybeans flower when the day length is less than a critical length, which varies with variety. Therefore, planting a variety at different dates is not a satisfactory method of changing maturity or harvest date. If a spread in maturity is desired, plant varieties that have different maturity dates.

The suggested planting dates for all soybean varieties in Tennessee are April 25 to June 15.

Row Spacing

Within the recommended planting dates, University of Tennessee research has shown that narrow-row soybeans, 20-inch widths or less, provide potentially higher yields under favorable fertility, moisture and sunlight conditions. Under stress conditions, narrow rows have not reduced yields. When planting later than the recommended planting date, always plant in row widths of 20 inches or less. Narrow-row spacing is recommended when planting late or using the no-till method of planting into small grain stubble or sod.

Seeding Rate

Seeding rate depends on size of seed, width of row and germination rate of seed. Because of the large variation in seed size among different varieties and within varieties from year to year, the measurement of seeds per foot of row is a better planting rate guide. Suggested seeding rates for the various row widths and planting methods are listed below:

(Note: Increase seeding rate if seed germination is below 80 percent, if soil crusting is expected or if planting soybeans after June 15).

Table 2. Seeding Rate

Row width (inches)	Feet of row per acre	Seeding rates (seeds/ft.)	(plants/ft.)	Final plant population/A
Conventional				
40	13,068	10-12	8-10	104,544-130,680
30	17,424	8-10	6-8	104,544-139,392
20	26,136	6-8	5-7	104,544-156,816
10	52,272	4-6	3-5	156,816-261,360
7	74,674	3-5	2-4	149,348-298,696
No-till				
20	26,136	8-10	6-8	156,816-209,088
10	52,272	6-8	4-6	209,088-313,632
Broadcast	40-60 lbs./A			

Seed Size

The size of soybean seed varies (seed per pound) with varieties and among varieties. Below is a table that shows the number of seed per bag at various seed sizes:

Table 3. Seed Size

Seeds/lb.	Seeds/50 lb. bag	Seeds/60 lb. bag
2500	125,000	150,000
2600	130,000	156,000
2700	135,000	162,000
2800	140,000	168,000
2900	145,000	174,000
3000	150,000	180,000
3100	155,000	186,000
3200	160,000	192,000
3300	165,000	198,000
3400	170,000	204,000
3500	175,000	210,000
3600	180,000	216,000
3700	185,000	222,000
3800	190,000	228,000
3900	195,000	234,000
4000	200,000	240,000

Table 4. Soybean Planting Guide

Row width (inches)	Desired seeds per acre (thousands)					
	100	125	150	175	200	225
	Seeds per foot of row					
5	0.9	1.2	1.4	1.7	1.9	2.2
7	1.3	1.7	2.0	2.3	2.7	3.0
10	1.9	2.4	2.9	3.3	3.8	4.3
15	2.9	3.6	4.3	5.0	5.7	6.5
20	3.8	4.8	5.7	6.7	7.6	8.6
30	5.7	7.2	8.6	10.0	11.5	12.9
36	6.9	8.6	10.3	12.1	13.8	15.5
38	7.3	9.1	10.9	12.7	14.5	16.4

For other planting rates or spacing: seeds per foot = planting rate divided by (522,720 divided by row width [inches])

Planting Depth

Soybean planting depth should be regulated by soil texture and moisture. With conventional planting, plant 1 to 2 inches deep in moist soil. When no-till planting, plant 1.5 inches deep. Do not plant soybeans deeper than 2 inches when using either method of planting.

Stages of Soybean Development

Table 5. Description of Vegetative Stages

Stage no.	Abbreviated stage title	Description
VE	Emergence	Cotyledons above the soil surface.
VC	Cotyledon	Unifoliolate leaves unrolled sufficiently so the leaf edges are not touching.
V1	First-node	Fully developed leaves at unifoliolate nodes.
V2	Second-node	Fully developed trifoliolate leaf at node above the unifoliolate nodes.
V3	Third-node	Three nodes on the main stem with fully developed leaves beginning with the unifoliolate nodes.
V(n)	nth-node	n number of nodes on the main stem with fully developed leaves, beginning with the unifoliolate nodes. n can be any number beginning with 1 for V1, first-node stage.

Table 6. Description of Reproductive Stages

Stage no.	Abbreviated stage title	Description
R1	Beginning bloom	One open flower at any node on the main stem
R2	Full bloom	Open flower at one of the two uppermost nodes on the main stem with a fully developed leaf.
R3	Beginning pod	Pod 5 mm (3/16 inch) long at one of the four uppermost nodes on the main stem with a fully developed leaf.
R4	Full pod	Pod 2 cm (3/4 inch) long at one of the four uppermost nodes on the main stem with a fully developed leaf.
R5	Beginning seed	Seed 3mm (1/8 inch) long in a pod at one of the four uppermost nodes on the main stem with a fully developed leaf.
R6	Full seed	Pod containing a green seed that fills the pod cavity at one of the four uppermost nodes on the main stem with a fully developed leaf.
R7	Beginning maturity	One normal pod on the main stem that has reached its mature pod color.
R8	Full maturity	Ninety-five percent of the pods have reached their mature pod color. Five to 10 days of drying weather are required after RX before the soybeans have less than 15 percent moisture.

Reprinted from Special Report 80, Stages of Soybean Development, by Walter R. Fehr, Iowa State University and Charles E. Caviness, University of Arkansas.

Figure 1. Reproductive Stages of Soybeans.

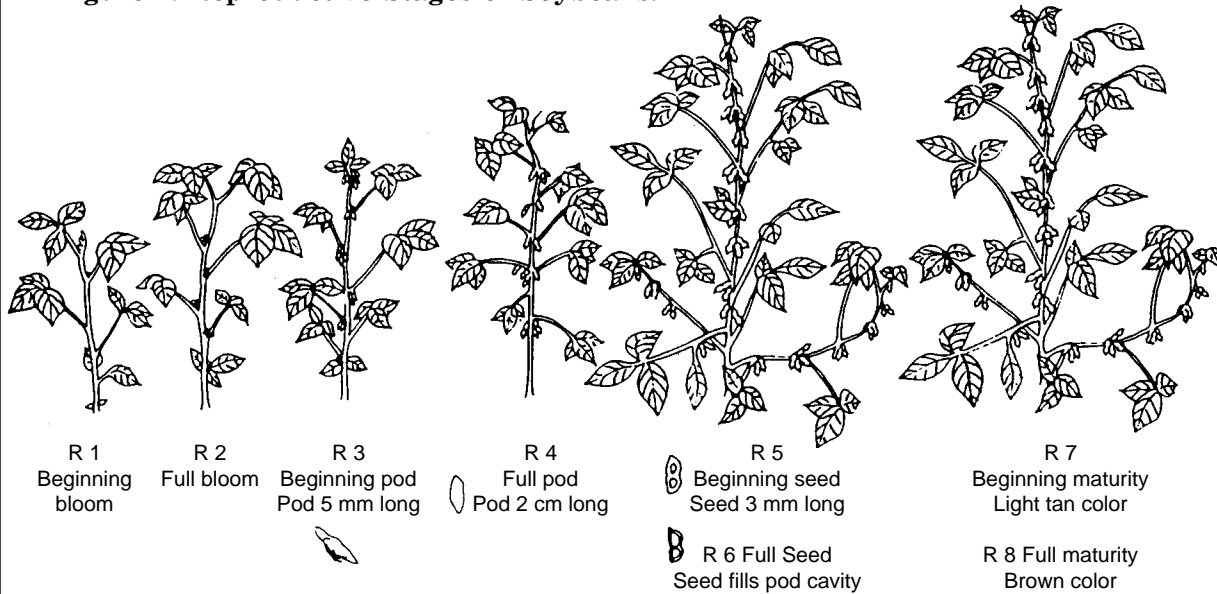

(Reprinted by permission of the southern Soybean Disease workers, from W. J. Walla, ed., 1978. Soybean Disease Atlas).

Variety Selection

It is very important to select a variety that is adapted to conditions where it will be grown. For convenience, soybean varieties have been divided into 10 maturity groups, 00 through VIII. Varieties in the 00 group are the earliest in maturity and are adapted to the northernmost production areas of the United States and southern Canada. Group VIII varieties are late and are grown near the Gulf of Mexico.

Varieties adapted to Tennessee growing conditions are in Groups IV, V and VI. Varieties in Group IV are early-maturity, varieties in Group V are medium-maturity and varieties in Group VI are late-maturity. Planting varieties with dif-

ferent maturity dates can take advantage of rainfall distribution during the growing season, lengthen harvesting time and permit more acres to be harvested with each combine.

Soybean variety tests are conducted each year at four to six locations in Tennessee with the three maturity groups to obtain information used to assist producers in selecting top-performing varieties. Varieties in each maturity group that perform above the average of the test for three years are put on the recommended list. Not only do varieties have to yield well, but they must also have other agronomic characteristics that are suitable for Tennessee conditions. For current recommended varieties, please see the latest list published.

Soil Management

*H. Paul Denton, Professor
Plant and Soil Sciences*

Land Selection

Like most crops, soybeans perform best on deep well drained, loamy soils with a high water-supplying capacity. However, soybeans are more widely adapted to less ideal soil conditions than corn. Because they can be planted relatively late, they are well suited to wetter soils that dry out slowly in the spring. Soybeans are more drought-tolerant than corn because they have a longer flowering period.

Even with a wide range of adaptability, there are soils in Tennessee so droughty or so wet that profitable yields cannot reasonably be expected in most years. Severely eroded, sloping, shallow soils are unable to supply adequate water in most years, and should be avoided. Likewise, soils that remain wet into the summer or frequently flood during the growing season should be avoided. County soil surveys can be used to help determine which soils are not likely to produce profitable yields.

Soybean production using intensive tillage has a high erosion potential. Adequate conservation practices need to be used on land with more than 2 percent slope to maintain long term productivity in soybean production systems.

Tillage Systems

Long-term research by The University of Tennessee has shown little effect of tillage systems on soybean yield on good soils. On deep, medium-textured soils, generally any tillage system with a good stand and good weed control will produce about the same yield. No-till yields have equaled those from conventional tillage in side-by-side tests planted at the same time for 10 years.

Farmer experience and research from other states have indicated yield increases from no-till on sloping, droughty land. The yield increases are probably due to less runoff of rainfall. Because of better water conservation and erosion control, no-till production is highly recommended on sloping upland fields.

Compaction and Deep Tillage

In general, soil compaction is not a widespread problem in soybean production in Tennessee.

The silty to clayey soils commonly found in Tennessee fields are not easily compacted. Research by The University of Tennessee has not shown any soybean yield response to subsoiling or deep chiseling. However, there are a few situations in which yield-limiting compaction may occur. These include:

1. Sandy soils. These are not common in Tennessee but may be found on some river bottoms and terraces.
2. Wet soils which have been frequently tilled with a disk when too wet.
3. Heavy traffic areas such as field roads or field edges, especially if trafficked when wet.

In these situations, deeper tillage to break up a compacted zone may be beneficial. In most cases, these compacted zones will be near the surface and can be disrupted by a chisel plow, but a paraplow or similar implement may be preferred in some cases because of less surface disturbance.

Subsoiling in Heavy Clay Soils in the Mississippi River Bottoms

Research in Mississippi and Arkansas has shown profitable soybean yield increases from fall subsoiling followed by minimum tillage on heavy black "gumbo" clay soils in the Mississippi River Bottoms. Yield increases have been greatest on soils with 20 to 40 inches of clay overlying sandy or loamy soil. Typical soil types are Tunica and Keyespoint. Yield increases have not been as great on deeper clay soils like Sharkey and Alligator.

There are no data from deep tillage research in Tennessee on these soils. However, if producers want to try this practice based on results from surrounding states, here are some key points to consider:

1. The tillage must be done when the soil is relatively dry to be effective. If the soil is wet, it will flow around the subsoil shanks rather than shatter. Therefore, spring subsoiling or subsoiling in late fall after the soil has rewetted has not been effective in increasing yields. Getting soybeans harvested in time to use this

practice has been a problem in Tennessee.

2. Minimum tillage or no tillage should be used following subsoiling to avoid recompacting the upper parts of the soil.
3. If the soil surface is left too rough to plant behind subsoiling, it probably should be smoothed by minimum tillage in the fall and planted “stale seedbed” in spring. Experience has shown that spring tillage on these soils creates very cloddy seedbeds.
4. The effect of winter flooding on subsoiling response is not known.
5. On deeper clayey soils like Sharkey, subsoiling has sometimes resulted in poor trafficability the next year by creating slots which hold water in the subsoil.
6. Subsoiling is time-consuming, hard on equipment and generally costly. It has rarely shown yield responses on most Tennessee soils. Proceed cautiously.

Soil Conservation and Residue Management

Soils have a high potential for erosion on sloping land if tillage is used. No-till is the most feasible way to produce soybeans while controlling erosion on slopes of 2 percent or more (see Table 7). Yields are equal to or better than those on tilled

fields, and production costs are about the same.

Successful no-till requires a good surface residue cover. For acceptable erosion control, residue cover of 50 percent or more at planting is needed. Soybeans are a low-residue crop. When grown continuously on strongly sloping land, they may not produce enough residue for adequate erosion control, even in continuous no-till. However, when rotated with high-residue crops like corn and wheat using no-till, soybeans can be grown on highly erodible land with very little soil loss (Table 7).

If continuous soybeans are grown, or if soybeans are rotated with cotton, cover crops may be needed to provide enough residue cover. Wheat is the most commonly used cover crop. It can be established by overseeding in the standing crop before leaf drop, or by a no-till drill after harvest. Tillage to establish a cover crop after harvest may be worse than doing nothing, particularly if the cover is planted after November 1. The fall growth of the cover will be too sparse to provide adequate cover for erosion control.

Table 7. Relative Soil Erosion from Soybean Production Systems

Crop rotation	Relative erosion rate as a percent of continuous-tilled soybeans
Continuous tilled soybean, 30-inch rows	100
Continuous tilled soybean, drilled	87
Tilled corn/tilled wheat/tilled soybean	52
Continuous no-till soybean	33
No-till corn/no-till soybean	22
No-till corn/minimum till wheat/no-till soybean	15
No-till corn/no-till wheat/no-till soybean	8

No-till Soybean Production

*Wayne T. Flinchum, Professor
Plant and Soil Sciences*

No-till soybean production continues to be an important practice in Tennessee. Factors contributing to this are:

1. Lower production cost due to reduced machinery, labor and energy requirements.
2. Reduced soil erosion.
3. Yields equal to or greater than conventionally planted soybeans.
4. More intensive use of resources and opportunity for expanded farming operations with the surplus labor and equipment.

No-till allows the production of soybeans on land that otherwise could not be continuously row-cropped. In no-till soybean production, no tilling operation is done prior to or following planting. The soybeans are planted into an unprepared seedbed by opening a narrow slit or trench of sufficient width and depth for proper soil coverage of the seed.

No-till soybeans can be grown on any soil type suitable for soybean production. However, soybeans should not be planted no-till in fields that are heavily infested with dallisgrass, perennial vines (trumpcreeper, wild sweet potato, etc.) unless the Roundup Ready® Technology is used. Where feasible, rotating to corn will generally improve problems with perennial vines.

Mulches

A mulch or ground cover is of utmost importance to successful no-till soybean production. The mulch reduces soil erosion, lowers moisture evaporation, helps prevent crusting and improves water infiltration and percolation. The mulch also aids considerably in weed control. Several different mulches are used in the planting of no-till soybeans.

Small Grain Stubble

Small grain stubble (especially wheat) is commonly used as a mulch for no-till soybeans. Best results are obtained with a uniform stand of early-to medium-season wheat. Wheat or other small grains should be combined to leave a minimum of 8-inch stubble height. The straw should be chopped

and spread uniformly over the stubble. Soybean planting should be done as soon after harvest as possible for good weed control and to prevent soil moisture loss.

Winter Cover Crop

The growing of small grain or other cover crops in the winter is an excellent deterrent to soil erosion and makes a good mulch for no-till soybeans.

If the winter cover crop is grazed, livestock should be removed in sufficient time to allow regrowth of at least 4 inches for better ground cover and more effective kill from the contact herbicide. Winter cover crops allow for earlier planting than in small grain stubble. However, lower soil temperatures under the mulch may delay germination.

Old Crop Residue

Crop residues from corn, cotton, soybeans or grain sorghum have been used as a mulch. However, they are not as effective a mulch as are small grains. Special attention to weed control is necessary to successfully no-till in old crop residues. Perennial weeds such as horseweed (marehail) and goldenrod have been a bigger problem in old crop residue than in small grain stubble. In addition, more extensive growth of winter annual weeds is common. These problems make the selection of the burndown chemical more critical. Either "Roundup Ultra®" or "Touchdown®" is recommended where johnsongrass or other perennials are present. "Gramoxone Max®" is not effective on most perennials. Old crop residue allows earlier planting of soybeans than when planting into wheat stubble. Earlier planting usually means more moisture for activation of the preemergence herbicides and normally increased soybean yields.

Old Pasture Sod

Old sod makes an excellent mulch for no-till soybeans. Pastures infested with broomsedge should not be no-till planted because present herbicides will not effectively control these weeds. This type of pasture should be tilled and planted conventionally until problem weeds are under control.

No-till Planting Equipment

Planters designed for no-till planting are essential. Some important components of no-till planters are coulters, double-disk openers and press wheels. The function of the coulters is to cut through the mulch and open a furrow. Seed is placed in the ground at proper depth between the disc openers. Press wheels cover seed and firm the soil for good seed-soil contact.

Coulters

There are three types of coulters used on no-till planters: **ripple**, **fluted** and **smooth**. The main job of the coulters is to cut through the mulch and penetrate the soil deeply enough for the disc openers to place the seed at the proper depth.

Ripple coulters have a straight, sharp edge with ripples located near the edge. Ripple and smooth coulters open up a very narrow slot in the soil. Fluted coulters have curved edges and disturb the soil most. Planter speed must be regulated to prevent throwing soil from the slot with fluted coulters. Normal planter speed can be maintained when using the smooth or ripple coulters.

Ripple and smooth coulters cut through the surface residue somewhat better than fluted coulters. The wider the fluted coulters, the harder it is to penetrate surface residue and crusted soil. It is easier to align the double disc openers to a fluted coulters than to a ripple or smooth coulters, especially when planting across sloping ground.

Planters should be equipped with down-pressure springs, either on planter units or the complete coulters and unit assembly. Additional weight for coulters penetration of residue and/or dry-hard crusted soil should be added when needed. Weight that can be adjusted quickly is the most desirable. Planters with off-set disk openers do not require coulters except under extremely dry field conditions.

Varieties

Soybean varieties recommended for conventional planting are also recommended for planting no-till. The medium-maturing group V varieties produce higher yields than the later maturing group VI varieties. However, early-maturing group IV and late-maturing group VI varieties may be used to help take advantage of seasonal rainfall during the growing season and to help spread out the harvest season. Although cyst nematodes have not been as serious a problem following wheat when planted either convention-

ally or no-till, resistant varieties should be considered if the problem exists. Choose varieties from the recommended list.

Row Width

Recommended row width for no-till planting is 20 inches or less. The recommended seeding rate for 20-inch rows is 8–10 seed per foot of row, for a final stand of 6–8 plants. For 10 inch rows, seeding rate is 6-8 seeds per foot, for a final stand of 4–6 plants. Planting depth should be at least 1 1/2 inches but not more than 2 inches to insure adequate moisture and safety from preemergence herbicides.

Lime and Fertilizer

Limestone, phosphate and potash applications should be based on a soil test. When double cropping soybeans with small grain, the soil should be limed and fertilized for both crops prior to planting of the small grain. Follow soil test recommendations for total amount of phosphate and potash needed for both crops. When no-till planting into old crop residue or sod, the limestone, phosphate and potash can be applied on the soil surface before, during or after planting. If the soil pH is below 6.5, add 0.2 oz. molybdenum per bushel as a seed treatment at planting.

Diseases and Insects

Diseases and insects are no greater problem in no-till soybeans than in conventionally planted soybeans. Foliar fungicides are usually as effective under no-till systems as in regular planted soybeans. Varieties that respond to foliar fungicides under conventionally planted conditions will also respond under no-till conditions.

Weed Control

Because mechanical control of weeds in no-till soybeans is not feasible, chemical control is mandatory. Herbicides used in no-till soybean production fall into three categories: **burndown**, **preemergence** and **postemergence**.

Burndown herbicides kill existing weeds or grasses that are present at the time of application. The size of weeds is influenced by mulch quantity and the time of year when soybeans are planted. In harvested small grain stubble, weeds may be as tall as the stubble left by the combine. Harvesting removes most of the foliage from both broadleaves and grasses, reducing the amount of surface area for herbicides to

contact. This may reduce herbicide effectiveness because less chemical is absorbed and translocated to other parts of the plant. This is particularly true of weeds which emerge early, such as smartweed and giant ragweed.

A burndown herbicide is recommended on all no-till fields. Some burndown herbicides work by contact action (Gramoxone Max[®]) and others are systemic (Roundup Ultra[®] or Touchdown[®]). These herbicides are comparable on many annual weeds in Tennessee, but Roundup Ultra[®] or Touchdown[®] provides better control of some annuals such as fall panicum, horseweed (marestail) and smartweed, as well as most perennials, including johnsongrass. When using Gramoxone Max[®], be sure to use at least 20 gallons of water per acre to insure adequate coverage. A good surfactant (at least 80 percent active ingredient) should be added at the rate of 1 to 2 quarts per 100 gallons of total spray solution. For Roundup Ultra[®] or Touchdown[®], use 10 to 20 gallons of water per acre. When using low rates of Roundup Ultra[®], be sure to use low-vol-

ume applications (10 gallons per acre). Flat-fan nozzle tips operated at medium pressure (minimum of 40 psi) give the best results with burndown herbicides.

The weed spectrum in many Tennessee no-till soybean fields necessitates the use of a residual grass and broadleaf herbicide combination. Frequently, these materials are tank-mixed with the burndown herbicide. The combined effects of a good mulch, narrow row spacing to promote rapid shading by the soybean canopy, a burndown herbicide and residual preemergence grass and broadleaf herbicides are sometimes adequate weed control measures. In other cases, postemergence herbicides are required. This is particularly true where johnsongrass and troublesome large-seeded broadleaf weeds are present, or where preemergence herbicides do not receive timely, adequate rainfall for activation. An overtop postemergence herbicide may be required. See the weed control section of this publication for herbicide rate and timing.

Soybean Weed Control

*G. Neil Rhodes, Jr., Professor
Plant and Soil Sciences*

Soybean weed management technology has changed rapidly over the past decade. The continued adoption of no-till (64 percent of the acreage in 2000) in Tennessee and other states has helped to shape the market for more surface-applied preemergence materials and fewer herbicides which require incorporation. Likewise, the development of more selective, over-the-top herbicides has allowed for a “wait and see” postemergence program approach in many fields.

The use of herbicide-tolerant crops (HTC's) in weed control programs has made significant inroads in soybean production. Sulfonylurea tolerant soybeans (STS[®]), Roundup Ready[®] soybeans and Liberty Link[®] soybeans are examples.

Regardless of your overall weed management strategy, a number of common denominators continue to hold true today, just as they have in the past. Narrow rows to promote early shading; a wheat stubble, winter cover crop or old crop resi-

due mulch to help suppress weeds; proper herbicide selection, application and timing; and selection of a recommended, fastgrowing soybean variety are examples. One of the oldest cultural weed control inputs is crop rotation. A rotation with corn is even more valuable now, particularly when the development of weed biotypes resistant to herbicides is considered.

Producers are encouraged to continuously evaluate results and costs of weed control programs on a field-by-field or farm by-farm basis. You may be using the most effective, economical program already. On the other hand, you may need to make some critical changes on a portion of your fields.

For soybean weed control recommendations, please see the latest edition of “Weed Control Manual for Tennessee,” PB 1580.

Disease Management in Soybeans Using Cultural Practices and Genetic Resistance

*Melvin A. Newman, Professor
Entomology & Plant Pathology*

At least 15 diseases can cause economic loss to soybeans in Tennessee. It is not probable that all these diseases will be present at the same time. However, there are at least four major diseases that Tennessee producers should fear. These include stem canker (SC), sudden death syndrome (SDS), soybean cyst nematode (SCN) and frogeye leaf spot (FLS).

The first step in controlling the major soybean diseases should be an accurate diagnosis of the particular disease situation. Sometimes producers may use a cultural practice or cultivar again and again just because it has been successful. This may be wise with some crops but without close observation and knowledge of disease symptoms, diseases can unknowingly build up to the point of severe yield reduction.

Stem Canker

Stem canker, caused by *Diaporthe phaseolorum* var. *caulivora*, kills soybean plants from mid-season to maturity. Dead plants with dried leaves still attached may be the first indication to the producer of the disease's presence. Usually a brown, slightly sunken lesion girdles the stem at the base of a lower branch or leaf petiole. These lesions begin as small, confined areas but enlarge and spread rapidly until the stem is girdled and the part of the plant above the canker is damaged or killed. Typical leaf symptoms are interveinal chlorosis and necrosis. When split, infected stems may show a light brown discoloration of the vascular area with the pith turning chocolate brown. Many times, yield reductions with susceptible cultivars can range from 50-90 percent, depending on several environmental factors.

Sudden Death Syndrome

Symptoms of interveinal chlorosis and necrosis of sudden death syndrome caused by *Fusarium solani* are very similar to those of SC. Instead of remaining attached, leaves with SDS symptoms fall prematurely, leaving the petioles attached.

Lower stem and roots are discolored more severely near maturity, with the pith remaining normally white. Lateral and tap roots are typically severely rotted at maturity, making it very easy to pull plants from the soil. SDS is usually found in fertile, productive soils where moisture is abundant and SCN is present. Yields with highly susceptible cultivars can be sharply reduced, but SDS is usually localized within a given field, while stem canker attacks on a field-wide or area basis.

Soybean Cyst Nematode

Symptoms caused by *Heterodera glycines*, the soybean cyst nematode, include various degrees of yellowing of the foliage, stunting of the plant, lack of nodulation and reduced yields. Infested fields usually show round to oval patterns of stunted and/or yellowed, unthrifty plants. Infested roots usually have very small, white or yellow cysts loosely attached. The cyst can easily be seen on the roots of susceptible cultivars 30-35 days after germination of the seed. Damage to susceptible cultivars can range from slight to severe depending on the number of cysts and the soil environment.

Frogeye Leaf Spot

Frogeye leaf spot caused by *Cercospora sojina* is primarily a foliar disease; however, infections may also occur on stems, pods and seeds. After mid-season, minute, reddish-brown, circular-to-angular spots first appear on the upper leaf surface. As the lesions enlarge with age, the central area becomes olive-gray or ash-gray, surrounded by a narrow, dark, reddish-brown border. Older spots become very thin, often paper-white and translucent. Lesions range from 1-5 mm in diameter but may coalesce to form larger irregular spots. Yields are reduced when lesions are numerous and leaves wither and fall prematurely. Recorded losses have been as high as 50 percent when conditions are conducive for disease development.

Control Measures

Correct cultivar selection is the best means of controlling these four major diseases. But, very few if any cultivars are highly resistant to all four. However, many cultivars are resistant to at least one or two of these diseases.

The first step in control is to obtain the results of a SCN soil analysis. In Tennessee, nematologists and plant pathologists consider 100 cysts per pint of soil as an economic threshold (ET). Damage from this number of cysts may vary somewhat from field to field, depending on several factors such as soil type, moisture, soil fertility and cropping history.

If SCN numbers are below ET, then cultivar selection is fairly simple, since there are many SCN susceptible cultivars resistant to SC and SDS in the maturity group desired. Selection may be further complicated by other diseases or nematodes such as the root-knot nematode.

When SCN numbers are above ET, a SCN-resistant cultivar should be selected with resistance to the race of SCN present to reduce the likely chance of nematode damage. But, with SCN resistance usually comes SC susceptibility. However, breeders are continuing to improve soybean cultivars with multi-disease-resistant characteristics. To reduce SC damage, producers are advised to plant later in the recommended planting time. Later plantings can reduce SC damage in most seasons. In Tennessee, several years of data show when Benlate (benomyl) is sprayed at the V4 vegetative stage (about 6 – 10 inches tall) on cultivars susceptible to SC, yields are significantly increased. When planting early in a no-till situation, cultivars highly susceptible to SC should be avoided. On the other hand, no-till has proven to reduce damage from cyst nematode and brown spot. Planting later reduces SDS and FLS damage somewhat. Some plant pathologists report more damage from SDS under no-till conditions and following corn.

Frogeye leaf spot can easily be controlled with the use of resistant cultivars, but when this is not possible, foliar applications of Benlate or another recommended fungicide can reduce the damage significantly. Method of tillage in Tennessee seems to have no effect on severity of FLS. However, crop rotation should reduce the severity somewhat.

Soybean Seed Treatments

Researchers have shown significant increases in germination and yield over the past several years with seed treatment fungicides. On the av-

erage, a 3 – 4 bushel per acre yield increase can be expected with a recommended seed treatment.

Germination and seed quality may be reduced by foliar and seed pathogens. This occurs especially when wet and humid weather conditions prevent producers from harvesting soybeans at maturity. The longer adverse weather conditions prevail, the more severe the damage will be to beans remaining in the field.

There are many formulations of soybean seed treatments on the market. Producers should check the label on the container for the following recommended fungicides: Captan, Thiram, Terracoat (PCNB), Chloroneb, Vitavax or many combinations of these. Captan and Thiram are good seed-surface sterilants and should be one of the components for best results. Metalaxyl is also present in some products and is effective against *Pythium*. Use label rates and directions for best results. These materials may be applied commercially by seed cleaners, dealers or by the producer on the farm with appropriate machinery. Take care to obtain uniform coverage on the seed.

Many hopper-box pour-on seed treatments can also be found to contain the recommended fungicides. This convenient method of application is effective, provided that uniform coverage is obtained on the seed.

Some fungicide formulations contain a water base and will evaporate rapidly, leaving a dry seed surface, while others may contain an oil base which promotes uniform coverage but may leave an oily seed surface. This is usually not a problem except with an air-type planter.

Summary

In summary, yield reduction from some diseases can be severe under favorable conditions. Although great advances have been made to produce resistant cultivars, very few, if any, are genetically resistant to all nematodes and diseases. Therefore, cultural practices such as crop rotation, foliar fungicides, seed treatments, method of tillage and time of planting must be used to supplement the desired disease and nematode resistance.

When producers know their particular disease situation and then select genetically resistant cultivars and cultural practices wisely, the risk from disease loss will be significantly reduced.

Soybean Insect Management

*Ronnie W. Seward, former Assistant Professor
Entomology & Plant Pathology*

Integrated Pest Management (IPM) is a concept which includes controlling crop pathogens, weeds and insects. A combination of IPM methods is included in a production system: soil sampling, soil preparation, nutrient management, cultivar selection, planting dates, row spacing, seeding rates, water management, scouting and the use of pesticides that will keep all pests below an economic injury level.

Monitoring/Detection/Sampling

Monitoring (scouting) is a fundamental part of any IPM program because treatment decisions are based on past and current pest numbers. Each type of pest requires specific sampling methods—either disease symptoms, weeds or insect activity. Good management requires systematic sampling and detection. Insect pests are very mobile and enter fields at different stages of crop growth. Therefore, sampling techniques and economic injury levels vary during the crop growing periods from bloom to pod fill to maturity.

Economic Injury Level (EIL)

This is the level of a pest population capable of an amount of damage, which, if prevented, would offset the cost of treatment applied. The cost of action taken equals the benefits received. Determining economic injury levels is an important part of an IPM program. Economic Threshold (ET) is a pest population level just below the economic injury level where an application of pesticide should keep the population from reaching the EIL. The economic threshold provides a margin of safety between detection and the point of action taken. Information, suggested treatment levels (ET) and materials in this chapter refer to insect and mite control in soybeans.

A practical determination of an economic threshold has been made on leaf area reduction and yield loss or number of insect pests which cause pod losses and therefore yield loss. This level varies with plant growth stage. Neither the market value of soybeans nor the expected yield in the absence of damage has been included in this threshold determination.

Many different insects can be found on soybeans in Tennessee. Some are detrimental, while

others are beneficial. The most economical and effective program begins with proper insect identification and a determination of possible economic damage. Serious reductions in yield and grade may result if an outbreak of an insect pest occurs and is not controlled. Some of these pests feed on leaves and stalks; others are primarily pod feeders. In most years, insecticides are not needed for control, but in some cases, damaging localized populations are not noticed until serious damage has occurred.

Insect Identification

Foliage Feeders

Loopers: Loopers are often the most common “worms” on soybeans. They are light green and have two pairs of abdominal prolegs. The body is largest at the rear and tapers to the head. These insects form the characteristic hump or “loop” when crawling. When populations are heavy, loopers eat much of the leaf surface, causing plants to look very ragged. Some insecticides have limited effectiveness for looper control. Naturally-occurring diseases help keep populations in check.

Green Cloverworm: The green cloverworm is a slender green caterpillar with three pairs of abdominal prolegs. It becomes very active and falls to the ground when disturbed. The feeding damage produced by the green cloverworm is similar to that of loopers. Although they are present most of the growing season, they are damaging only with very high populations or in combination with other defoliators.

Japanese Beetle: Japanese beetle adults are metallic green or greenish bronze beetles, 1/2-inch long, with reddish wing covers. They have white spots near the tip of the abdomen and on the sides. As they feed on soybean foliage, Japanese beetles skeletonize the leaves.

Bean Leaf Beetle: The bean leaf beetle feeds on leaves and sometimes on small pods. The beetles may feed through the pod and eat the beans, leaving damage which resembles bollworm feeding. The adults can cause severe damage on small

plants. The larvae feed on roots, nodules and underground portions of the stems. Adults are reddish to tan, usually with four dark spots on each wing.

Mexican Bean Beetle: Mexican bean beetles damage plants by feeding on the underside of the leaf surface, resulting in a skeletonized appearance. Both adults and larvae feed in a similar manner. Adults are copper brown with 16 black spots on the back. Larvae are yellow to brown, with many spines on the back and sides. Both adults and larvae are about 1/4 inch long.

Blister Beetles: Blister beetles are elongated, soft-winged beetles which feed on leaves. One species, the striped blister beetle, has alternating dark brown and yellow stripes running the length of the body. Another species, the margined blister beetle, is black with a gray stripe along margins of the wing covers. These insects usually feed in groups in one area of the field.

Pod Feeders

Fall Armyworm: The fall armyworm is a multicolored, striped caterpillar with an inverted “Y” on the head and four pairs of abdominal prolegs. Armyworms may feed on leaves, stems, pods and beans. They often appear in large numbers and quick control is important.

Corn Earworm: The corn earworm, also called the bollworm or podworm, can seriously reduce yields, since it feeds directly on beans by eating a hole in the pod and consuming the seed. Large caterpillars may be green, brown, yellow or black. The body is stocky and the head is usually pale brown or orange. Light and dark stripes run the length of the body. The larva has four pairs of abdominal prolegs. Young blooms and tender leaves are sometimes eaten. Beans should be checked during mid-August through September for this pest.

Stink Bugs: Stink bugs suck the juices from immature soybean seeds. This feeding introduces disease organisms into developing seeds, reduces germination and lowers milling quality. Damaged beans appear wrinkled and smaller than normal. These bugs are shield-shaped, either green or brown, and are about a half-inch in length.

Stem and Seedling Feeders

Three-Cornered Alfalfa Hopper: The three cornered alfalfa hopper is a green, wedge-shaped insect about 1/4 inch in length. Adults and nymphs feed by inserting their piercing-sucking mouthparts into the stem a few inches above the soil line. This feeding around the stem girdles the plant, causing it to later lodge. Maintaining a clean field border reduces population numbers.

Table 8. Suggested Threshold Levels for Insects

Foliage-feeding insects (defoliation)	30 percent to bloom; 20 percent from bloom to pod fill; 30 percent pod fill to maturity
Pod-feeding insects	Earworms—4 per ft. of row Stinkbugs—1 per 3 ft. of row from bloom through mid-podfill; 1 per ft. of row from mid-podfill to maturity Fall Armyworm—4 per ft. of row
Stem-feeding insects	Three-cornered alfalfa hopper. 10 percent of plants (up to 101 2 inches) are infested with adults and/or nymphs.

Figure 2. Percent Defoliation

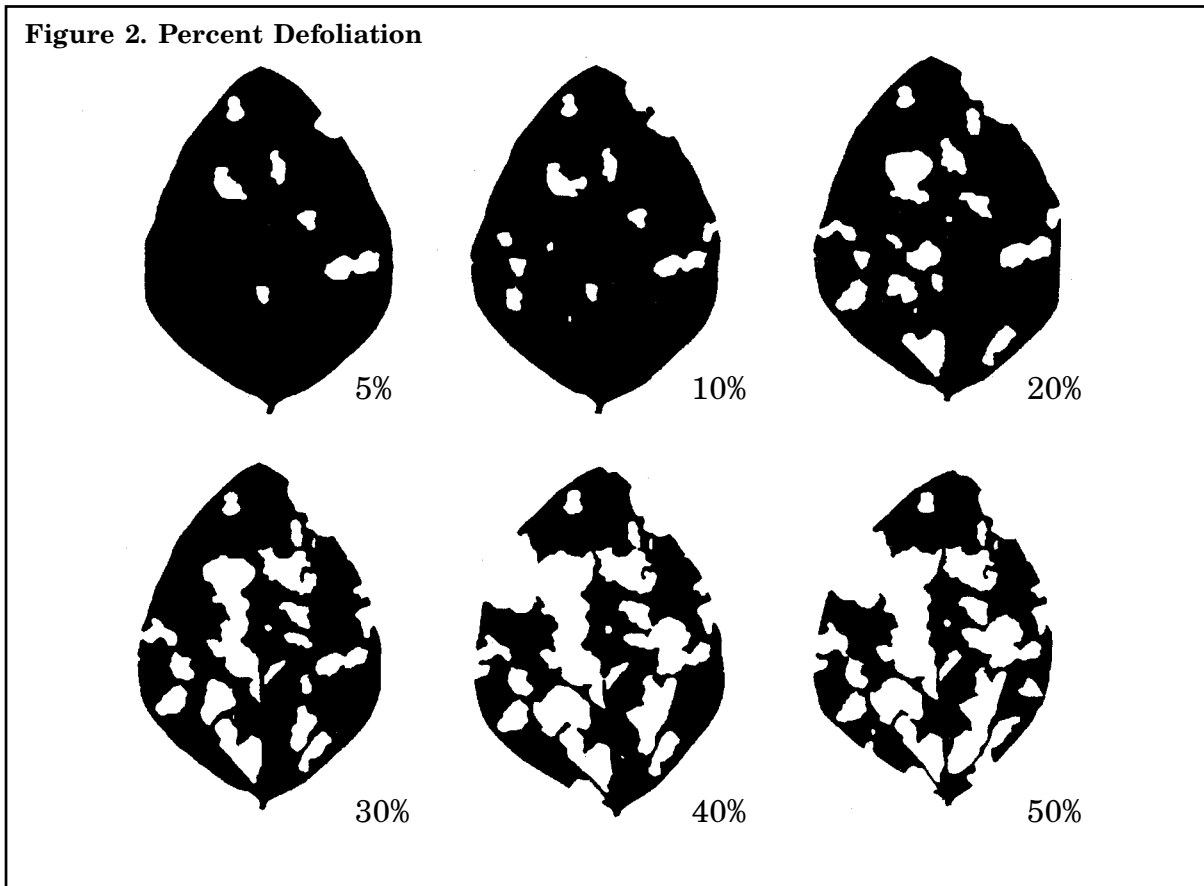

How to Check for Insects: To properly check soybeans for insects, all bean plants on 3 feet of row should be shaken vigorously over the row middle, preferably on something white, such as a cloth. Insects that fall can then be counted. Repeat this procedure at several areas in the field. Example: 3 feet of row at 10 locations = 30 feet.

For insect control recommendations in soybeans, please see the latest edition of "Soybean Insect and Mite Control," PB705.

Combining Soybeans Efficiently

James B. Wills, Jr., Professor
Agricultural and Biosystems Engineering

Several factors affect the quality of a given combine operation. These factors determine how much of the crop is harvested and how much of the crop is left in the field. The amount of crop left in the field is considered a harvest loss and represents dollars lost to the producer. The value of the crop per unit times the number of units gives a dollar value for the unharvested crop. For example, if soybeans are worth \$7 per bushel and three bushels are left unharvested on an acre, the loss to the producer is \$21 per acre. If the producer has 100 acres, the total loss would be \$2100. These are realistic figures and are common losses for the average producer on a per-acre basis. Ideal combine efficiency is 97 percent for most harvested crops. This figure means that acceptable losses are 3 percent of the crop. Average harvesting losses are closer to 10 percent in most crops. This means that producers can increase crop harvest and reduce losses by improving combine operation skills (see Graph 1).

Graph 1

Combine Harvest Losses
in dollars per Acre

Dollar loss per acre

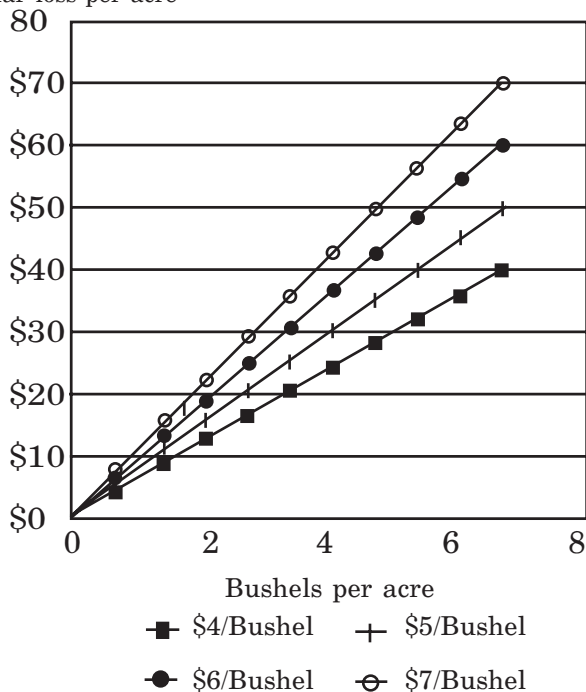

Some of the major factors that affect the quality of combining operations are:

- Weather
- Skill of the operator
- Condition of the field and crop
- Adjustment and condition of the combine
- Speed of forward travel
- Width of the combine header
- Feed rate of the material through the combine
- Variety of the crop
- Type of combine and the attachments used

When to Harvest Soybeans

Different crops, such as corn, wheat, sorghum and soybeans, will harvest best at a given moisture content of the crop. Some crops will harvest or thresh best at a specified moisture content, but will not store well without drying to a lower moisture content. Soybeans harvest best at 12 to 14 percent moisture and will also store well at this moisture level. Corn harvests best at 20 to 25 percent moisture, but stores best at 15 percent or less. For this reason, operators should begin harvesting when moisture content is ideal for threshing.

Recognition of Poor Combine Performance

A good combine operator must be capable of recognizing both good and poor performance by the combine. Indications of poor combine performance are:

- Grain losses on the ground
- Unthreshed kernels in the pod
- Straw chewed up excessively
- Grain lost from the straw walkers or cleaning shoe
- Excessive tailings in the tailings auger
- Cracked grain in the grain tank
- Chaff or trash in the grain tank
- Marketing penalties for low-quality grain due to harvesting damage or crop condition

The operator must be capable of making adjustments to the combine and operating the combine at proper ground speeds to optimize the efficiency of the combine during harvest.

Types of Harvest Losses

Combine operators can expect to encounter four types of harvest losses with a combine:

1. Preharvest losses are parts of the crop that are detached from stalks or pods and lying on the ground prior to the harvest. These losses should not be charged to the machine.
2. Gathering unit losses are caused by the header or picker unit of the combine. These losses are usually 90 percent of the total loss.
3. Cylinder losses include unthreshed seeds or kernels that are passed out the rear of the combine. These losses are only about 5 percent of the total losses from modern combines.
4. Separation losses are threshed seeds or kernels that are carried out the rear of the combine with the crop residue. These losses are about 5 percent of the total harvest loss with modern combines.

To check for harvest losses, the combine operator will need to check three locations, as shown in Figure 3. These three checks will give preharvest losses, gathering unit losses and threshing losses (cylinder and separation losses).

An area of at least 10 square feet should be examined at each checkpoint to establish reliable estimates. Frames can be constructed of known dimensions or string and pegs can be used to lay out check plots for counting harvest losses. A frame made of 1/2-inch diameter PVC pipe and four elbows can be easily constructed and carried on the

combine for checking losses. The frame can be sized according to the needs of the combine operator and based on the size of the combine in use. Frames 2 feet-by-2 feet are convenient to carry on most combines.

To check for harvest losses, operate the combine normally in the field. After harvesting an area about 50 feet long, stop the combine and back up about 15 feet. Check the preharvest loss by counting seed on the ground in the unharvested area in front of the combine (see Area 1 in Figure 3). Next, make a seed count in the area over which the combine header has passed. This count will give the gathering unit loss. Be sure to count seed in pods still attached to stubble (see Area 2 in Figure 3). Now, count all seed in an area behind the combine to determine threshing and separation losses (see Area 3 in Figure 3). Convert all seed counts to bushels per acre, using five seed per square foot equals one bushel per acre loss. The total of the gathering unit losses (Area 2) and separation and threshing losses (Area 3) are caused by the combine and the combine operator. The total loss from Areas 2 and 3 should not exceed 3 percent of the crop yield per acre. If they do, look for ways to reduce these losses by making adjustments to the combine, forward speed of travel or operator technique. The preharvest losses should not be blamed on the combine. These losses can be adjusted by timing of the harvest.

Condition of The Field and Crop

Cultural practices such as level seed bed preparation in small grain and soybean fields can greatly increase the amount of grain harvested. Ridges or furrows may prevent the combine header

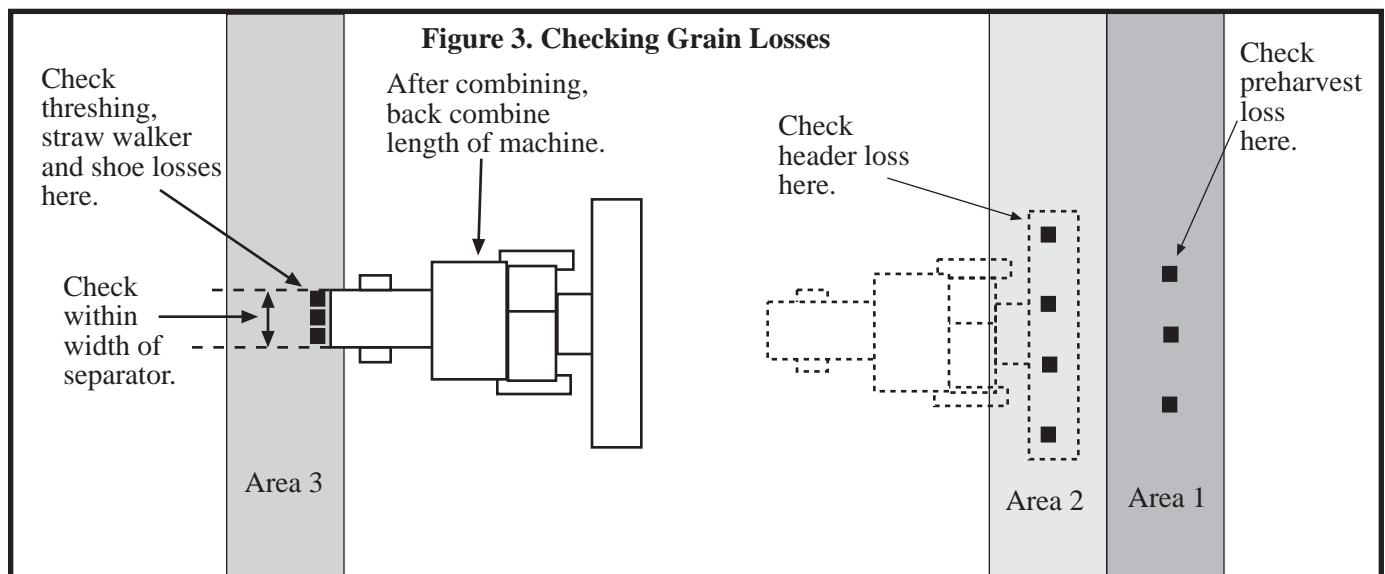

from harvesting all grain present. The header will ride along the tops of the ridges and will miss grain below the top of the ridge. This is especially true for soybean harvest. The smoother the soil surface when harvesting, the more grain the combine will be able to harvest.

Cultivation practices can also affect the amount of grain harvested. Ridging along rows will not allow the combine header to harvest any seed below the top of the ridges. Rolling cultivators should be adjusted to keep the ground level. Sweep cultivators with halfsweeps near the row can be effective. Shovel cultivation should be avoided, especially in wet soil where clods will be deposited in the row. The combine will float over the clods or cut through them at harvest time. Both of these situations are undesirable.

Weedy fields increase crop losses when combining (see Graph 2). Heavy infestations of weeds in fields to be combine harvested tend to keep crop moisture content higher than desirable for efficient threshing. Green material from the weeds will accumulate on the straw walkers of the combine and carry grain out the rear of the machine. Weeds also require more power to thresh the grain and pieces of the weeds usually end up in the grain tank with the grain.

Graph 2

Combine Harvest Losses
in Weedy and Weed-free Soybeans

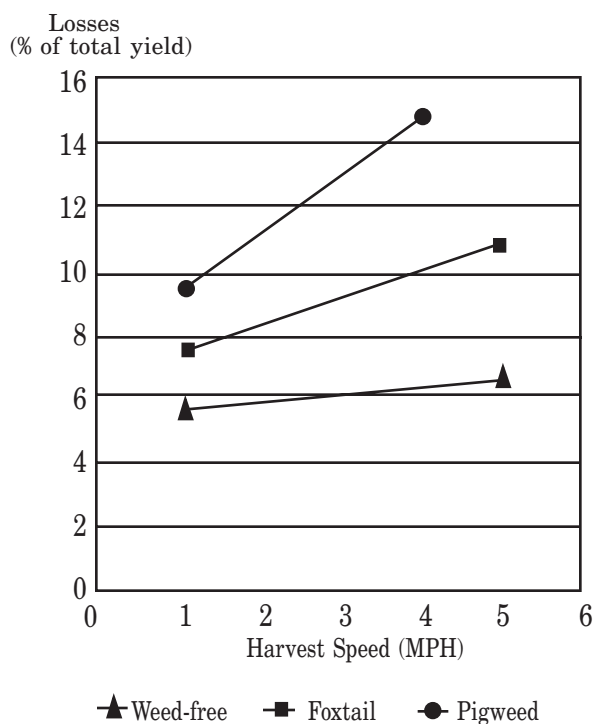

Operators can take some steps to reduce crop losses in weedy crops by observing the following recommendations:

1. Use a harvest aid: Roundup Ultra®, Sodium Chlorate or Gramoxone Extra®. (See the weed control section of this publication) or wait until after a killing frost or freeze when possible to do so. The weeds will be killed by the frost and will dry up in a few days. The combine can handle this dry material much more easily than heavy, green material.
2. Increase cutter bar height of the header. This reduces the amount of green material taken into the machine. If weeds are taller than the crop to be harvested, this is not an alternative.
3. Slow the forward speed of the combine to give the threshing mechanism more time to separate the grain from the weeds and stalks. Speeds of one to two miles per hour may be required.
4. Take a narrower cut with the header. This also reduces the amount of material in the threshing area of the machine at one time.
5. Increase the cylinder clearance slightly. This breaks up the weeds less and reduces power requirements slightly. Be careful to watch the straw walkers for overloading, as the material will pass to the walker area more quickly.
6. Cut and windrow the crop about a week or so before combining. This drying time will reduce the amount of material the combine must handle. The material will also be drier, which will permit better threshing action by the combine.

Weather can affect the harvest moisture conditions of crops. Ice and snow will melt from machine heat and cause the moisture content of the grain to increase. Moisture can cause dust to turn to mud and clog straw walkers, sieves and chaffers.

Adjustment and Condition of the Combine

Poor mechanical condition of combines can cause poor harvesting performance. Components which are worn or damaged cannot be adjusted to give proper harvesting performance. A machine which does not receive good preventive maintenance will usually cost more in repairs and down time than properly maintained machines. Repairs and preventive maintenance should be performed between seasons to avoid as much unnecessary down time as possible. The machine should be thoroughly examined before each harvesting sea-

son and all needed repairs completed before harvest time. Examples of some items to examine for damage or repairs include:

1. Header

- Knife guards, bent or broken
- Knives, broken or missing
- Worn or broken hold-down clips
- Broken reel slats
- Broken or missing pickup reel fingers
- Worn belts and chains
- Worn bearings
- Loose or missing bolts

2. Separator components

- Worn or bent cylinder bars
- Worn or bent concave bars
- Worn or loose drive belts or chains
- Dirt or mud packed in cylinder or concaves
- Misaligned cylinder and concave
- Damaged straw walkers
- Damaged fan blades
- Torn or missing straw walker curtain
- Worn or damaged sheaves

3. Whole machines

- Loose bolts
- Worn belts or chains
- Worn bearings
- Damaged controls
- Mud or dirt packed around bearings
- Holes in sheet metal and auger housings

Each combine operator’s manual has a list of suggested initial machine settings. These settings are starting points which must be carefully adjusted to achieve optimum harvesting efficiency. Field conditions, crop variety, operator technique and other factors will determine the exact adjustments for each combine. Conventional cylinder-type combines and newer rotary- type combines will not have the same adjustments, due to the different nature of the two combines. Listed below are some typical ranges of settings for conventional combines. Keep in mind that these are subject to adjustment when the combine is in the field and that the owner’s manual for a particular combine may differ from these settings. All recommendations in the owner’s manual should be followed if they differ from the settings suggested here.

Table 9. Adjustments for Conventional Combines for Optimum Soybean Harvesting

Cylinder speed	450 - 850 RPMs
Concave clearance	3/8 inch to 1 inch
Chaffer setting	1/2 inch to 3/4 inch
Sieve setting	3/8 inch to 1/2 inch

Rotary combines may have an indicator plate with a pointer for setting the concave clearance rather than using a measurement such as 1 inch or 1/2 inch. Manufacturer’s recommendations should be followed when making these adjustments.

Forward ground speed is one of the most important adjustments that a combine operator can make. Traveling too fast will cause poor threshing in normal crops, as the material will pass through the combine quickly and may not thresh adequately. Overloading of the combine will usually occur at faster than necessary ground speeds. This overloading stresses the machine and results in excessive crop loss. Proper ground speed is determined by the yield of the crop, ground surface conditions, the capacity of the combine and the skill of the operator. When beginning to harvest a field, an operator should operate the combine at a ground speed between 2 1/2 and 3 1/2 miles per hour. The forward ground speed can then be adjusted to the field and crop conditions.

Reel speed is another important adjustment the operator will need to make. Normally, reel speed should be 1.25 to 1.5 times the forward ground speed of the combine. The reel should appear to be pulling the crop into the header. The center axis of the reel should be about 8 to 12 inches in front of the cutter bar. The height of the reel should be adjusted to pull the grain heads into the header gently without carrying cut stalks and stems over the top of the reel.

Header width is another factor which can influence harvest losses. Machines with wide headers must usually travel at slower ground speeds to give the threshing mechanism time to adequately thresh the material passing through the machine. Wide headers gather more material per unit of time than narrow headers. The operator also needs to observe path of travel more closely to use the full width of the header.

Crop variety is another important factor to consider when attempting to reduce crop losses at harvest time. Varieties that “stand up” and resist lodging and adverse weather will usually produce more grain. Crops that lodge or get wind blown and lie on the ground are difficult or impossible for the gathering unit on the combine to collect for harvest. Some crop varieties are susceptible to disease and parasites that can weaken plant stems and cause them to fall over onto the ground. Use only recommended varieties for your area that have been tested for resistance to disease and weather damage.

Types of Combines

Two basic types of combines are currently marketed. The conventional “cylinder” combine has been in use for many years and will continue to function well for many years to come. The newer “rotary” combines have been in use for only a few years and offer a different threshing concept. Rotary combines may have one or two rotors for threshing. The rotor or rotors may be mounted along the long axis of the combine or parallel to the direction of travel (see Figures 4 and 5). The name usually given to these machines is axial rotor. Other rotary combines may have a rotor mounted transversely or perpendicular to the direction of travel (see Figure 6). Conventional cylinder type combines have a transversely mounted cylinder (see Figure 7).

Rotary combines are generally accepted to be more efficient and less damaging to grain than conventional combines. The cost of rotary combines is usually substantially more than the cost of conventional combines. The prospective user will have to make a decision concerning the merits and additional cost of the rotary combine versus the conventional type. Commercial seed companies will usually require seed producers to harvest seed crops with rotary combines to reduce damage to seed coats. This will produce more viable and healthier seeds to future growers.

Combine Evaluation

Combine performance can be evaluated by comparing the ability of one combine to another to handle grain and other materials. One method of evaluation is to compare the amount of material a combine can harvest and thresh in a given time period.

Two basic types of material pass through a combine during the harvest process. These are material other-than grain or MOG (straw, weeds, chaff, etc.) and grain (G). The MOG feedrate is the amount of straw, weeds, chaff and other plant material that passes through the combine per unit of time. The G feedrate is the amount of grain that passes through the combine per unit of time. If the MOG feedrate is divided by the G feedrate, a MOG/G ratio is established. This ratio is basically an indication of how difficult a given crop is to separate. For example, consider a MOG/G ratio of 1.5 to 1. This means that for every pound of grain that is harvested, 1 1/2 pounds of MOG must pass through the combine along with the pound of grain. Crops with low MOG/G ratios such as 0.5 to 1 are easy to thresh, since little foreign material is present to hinder the threshing process. Crops with high MOG/G ratios are more difficult to thresh.

We can use the same MOG/G ratio to compare combines on an equal basis. If one combine can handle four tons of material per hour and another combine can handle six tons of material per hour, the second combine is capable of handling 50 percent more material in the same amount of time. If timeliness is a major consideration when selecting a combine, then the second combine would have a definite advantage over the first one. Both combines have to be operated at the same loss levels for the comparison to be valid. That is, combine two may have harvested more grain but it may have lost more grain in the harvesting process. Therefore, a 3 percent loss is usually the accepted standard for comparing combines. This loss rate is widely accepted across North America as the optimum trade-off between work accomplished and grain lost.

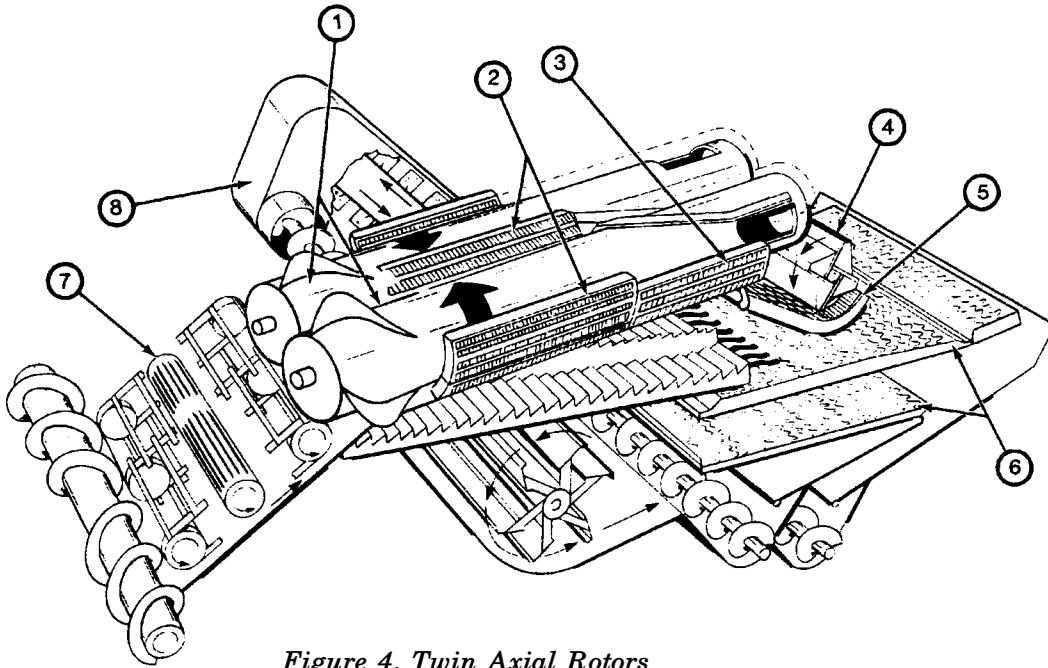

Figure 4. Twin Axial Rotors

- 1. Rotors; 2. Threshing Concave;
- 3. Separating Concave; 4. Discharge Beater;
- 5. Beater Grate; 6. Cleaning Shoe;
- 7. Stone Ejection Roller; 8. Tailings Return

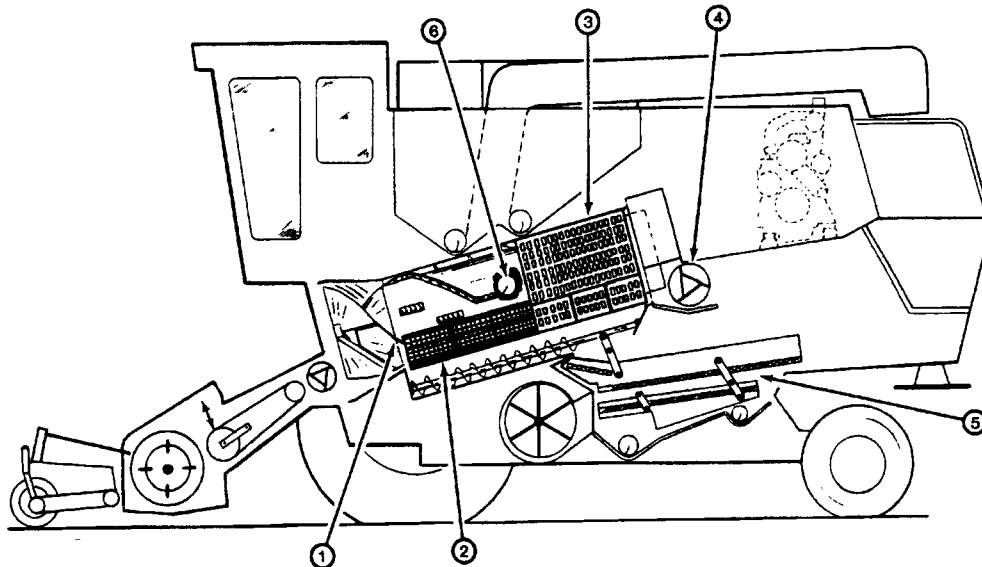

Figure 5. Single Axial Rotor

- 1. Rotor; 2. Threshing Concaves;
- 3. Separating Concaves; 4. Back Beaters;
- 5. Shoe; 6. Tailings Return

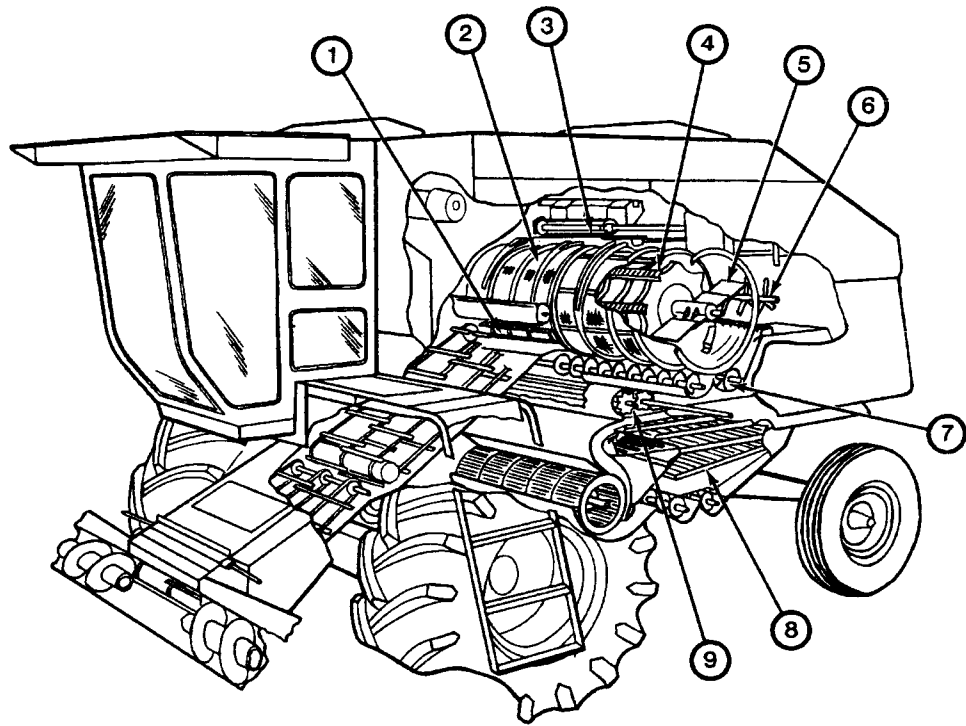

Figure 6. Single Transverse Mounted Rotor
 1. Concave; 2. Cage; 3. Cage Sweeps; 4. Rotor;
 5. Discharge Paddles; 6. Straw Chopper;
 7. Distribution Augers; 8. Cleaning Shoe;
 9. Accelerator Rolls

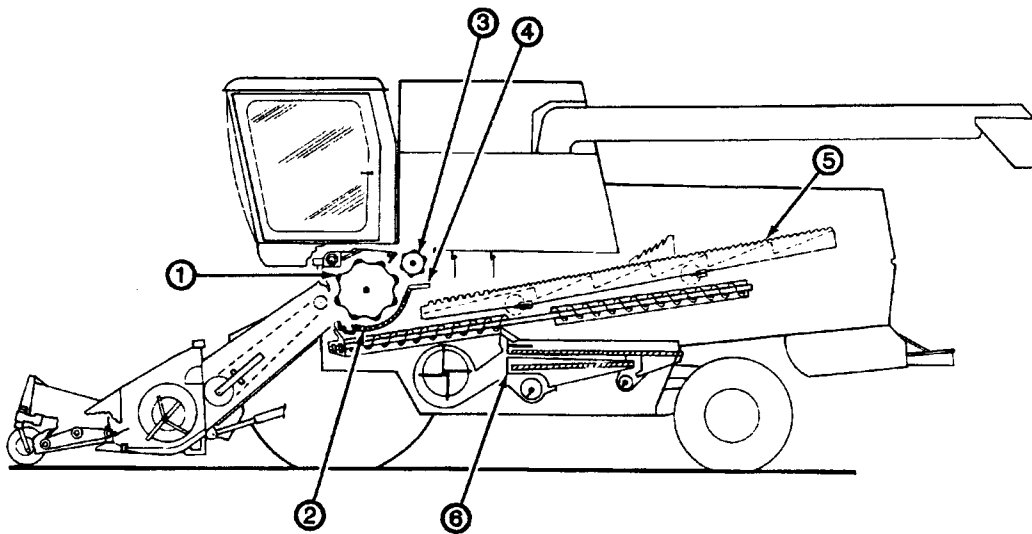

Figure 7. Transverse-Mounted Tangential Threshing Cylinder
 1. Cylinder; 2. Concave; 3. Beater; 4. Beater Grate;
 5. Straw Walker; 6. Shoe

Drying, Handling and Storing Soybeans in Tennessee

Michael J. Buschermohle, Professor

Agricultural and Biosystems Engineering, The University of Tennessee, and

Samuel G. McNeill, Assistant Professor

Biosystems and Agricultural Engineering, University of Kentucky

Soybeans have characteristics that differ significantly from other grain and oil seed crops. A softer seed coat allows the soybeans to lose and gain moisture more rapidly. The seed coat is less durable than other grains and so is more vulnerable to cracking and splitting during drying, storage and handling. It is also a crop with a higher value per bushel, which makes the risk from loss more serious economically. These differences dictate that the following guidelines for drying, handling and storage should be carefully followed to ensure maximum quality of soybeans sold on the market.

Handling

Handle the soybeans as little and as gently as possible, because the seedcoat is easily cracked. Damage to soybeans is more severe when conveyed at moisture contents below 12 percent. However, the most important factors to consider when conveying soybeans by augers are the fullness and speed of the auger. Augers should be run as full as possible and at low speeds. To keep an auger full, you must maintain a reservoir of grain above the inlet of the auger. More power is required to run the auger when it is full, so make sure the power unit is sufficient to handle the work load. It is best to keep auger speed below 400 rpm. Auger output is related to its speed and diameter; so, for a larger system capacity, a larger diameter auger will sometimes be required if the speed is kept low.

Drying

Drying of soybeans has usually been necessary only when inclement weather has occurred during harvest. Mature soybeans left exposed to rain or damp weather develop a dark brown color and a mealy or chalky texture that will lower the grade. Seed quality deteriorates rapidly with increased weather exposure. Oil from weather-damaged beans is more costly to refine and is often not of edible grade.

Artificial drying of soybeans offers advantages that merit consideration. It permits earlier harvest and reduces the chance of loss from bad weather. Early harvest at higher moisture contents reduces natural shatter loss from field weathering. Shatter loss from plant contact by the combine reel and cutterbar is also reduced.

Under certain conditions, natural (unheated) air can be used to dry soybeans. The amount of moisture that can be removed from soybeans depends on the moisture content of the grain before drying and the relative humidity and temperature of the drying air. When soybeans are dried with natural air, the moisture content of the grain tends to come into equilibrium with that of the drying air. If the air temperature and relative humidity are constant, the soybeans will come into equilibrium with the air and their moisture content will stabilize. This is known as the equilibrium moisture content.

Equilibrium moisture data from Table 10 is useful in determining whether soybeans will lose or gain moisture under a given set of air temperature and relative humidity conditions. To read equilibrium moisture content (wet basis), select any combination of temperature (degrees Fahrenheit) and relative humidity (percent) and read the equilibrium moisture content from the point where the two values meet in the table. This will be the point where the material will be in equilibrium with its surrounding air at that particular temperature and relative humidity. As can be seen from the table, drying will usually occur only when the temperature exceeds 60F and the relative humidity is below 70 percent.

Conventional drying equipment for corn can be used for soybeans with some limitations on the amount of heat added to the drying air. High-temperature batch or continuous flow dryers can be used to dry a large soybean crop or one with excess moisture if temperatures are controlled to minimize seed coat damage. Since these units usu-

Table 10. Equilibrium Moisture Content of Soybeans (%wb) at Different Temperature and Relative Humidity Levels

Temperature (degrees F)	Relative Humidity (percent)									
	10	20	30	40	50	60	65	70	80	90
35	2.2	4.3	6.1	7.8	9.6	11.5	12.5	13.7	16.5	20.5
40	2.1	4.2	5.9	7.7	9.4	11.3	12.4	13.5	16.3	20.3
50	1.9	3.9	5.7	7.4	9.1	11	12.1	13.2	15.9	20
60	1.7	3.7	5.5	7.1	8.9	10.7	11.8	12.9	15.6	19.6
70	1.5	3.5	5.2	6.9	8.6	10.5	11.5	12.6	15.3	19.2
80	1.3	3.3	5	6.7	8.4	10.2	11.2	12.3	15	18.9
90	1.2	3.1	4.8	6.5	8.1	10	11	12.1	14.7	18.6
100	1	3	4.6	6.3	7.9	9.7	10.7	11.8	14.4	18.3

Source: ASAE Data D245.4/Average of two Prediction Eqns.

ally have excess air capacity, artificial heat may not be needed for daytime drying when harvesting in the moisture range of 17 to 19 percent. When heat is used, limit the drying air temperature to 120 – 140F by cycling the burner on and off or by replacing/reducing the size of the gas burner orifices. Adjust the metering rolls to control the final moisture of the crop and avoid overdrying. Drying temperatures for in-bin drying systems should be maintained below 110F to prevent cracking and reduction of germination.

The relative humidity of the drying air is just as important as the drying temperature in maintaining quality. Heating the air reduces its relative humidity. Low-humidity air causes excessive splitting and cracking of the seed and seed coat. The relative humidity of the drying air should be above 40 percent to prevent excessive seedcoat cracking. Use of the rule “adding 20 degrees of heat to air reduces its relative humidity by one-half” gives a valuable tool in managing the use of heated air in drying beans. For example, if air is initially at 60F and 60 percent relative humidity, raising the temperature to 80F drops the relative humidity to 30 percent. Another useful rough approximation is that heating air 5 degrees reduces the relative humidity by 10 percent.

Soybeans should be cooled after drying because high temperatures can spoil the grain. To cool, shut the heater off and allow the fan to run until the grain is cooled. Some drying will occur during cooling and should be included in the desired drying time.

Storage

Soybeans on the commercial market are sold at 13 percent moisture. Nearly all storage problems may be traced to excess moisture in stored grain. Mold growth is dependent on both temperature and moisture content of stored grain and will be minimal below a relative humidity of 60 percent and a temperature below 50F. In time, soybeans stored at 11 percent moisture content will set these conditions (60 percent and 50F) as shown in Table 10. Thus, to assure safe storage, soybeans should be stored at not more than 11 percent moisture content. If soybeans are to be stored over the summer, the moisture content should be one to two percentage points lower to eliminate the possibility of spoilage during hot and humid weather (see Graph 3). When testing for moisture, take samples from several locations to be sure the grain throughout the bin is at the proper storage level.

Aeration

Soybeans stored in bins can spoil even if they are dried to the recommended storage moisture content. The most frequent cause of pockets of spoiled grain in storage is moisture migration, a phenomenon by which dry grain will re-wet and spoil. Soybeans, like all other grains, are good insulators. For this reason, soybeans near the center of the bin tend to maintain the temperature at which they came from the dryer or field. Soybeans near the bin wall tend to cool to near the average outside temperature. The heavier cool air

Graph 3. Equilibrium moisture content for soybeans at two temperatures.

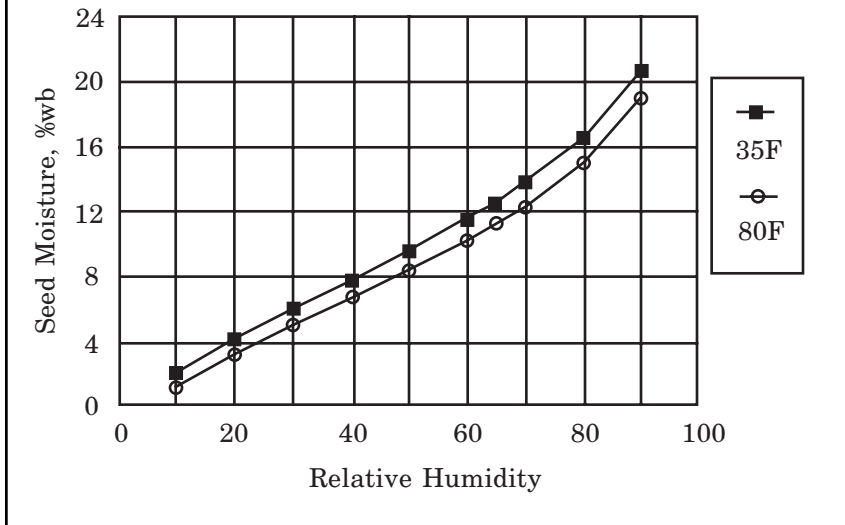

next to the bin wall becomes more dense and falls to the bottom of the bin, which forces warmer air up through the center of the bin. As this moist air passes through the center, it warms and picks up more moisture. When this warm air comes in contact with cool grain near the top surface, it drops its water (or condenses, much like condensation on cold windows) and causes a pocket of higher moisture grain at the top center of the stored grain. Crusting is an indication of moisture accumulation and mold growth. The reverse situation occurs during the summer months. In this case, the moisture condenses near the bottom center of the grain mass.

Moisture migration can be prevented by aeration. Aeration equalizes temperatures within stored grain and prevents these air currents from forming. Aeration can be accomplished with an adequately designed aeration system or with a drying fan (with heater turned off). The time required to aerate will depend primarily on the size of fan. Most on-farm aeration fans are sized for about 0.1 CFM/bushel airflow and require about 120 hours (5 days) of continuous operation for clean grain or 150 – 175 hours (6 – 7 days) to complete an aeration cycle in bins with a peaked cone of grain containing a column of fines in the center of the bin. You can estimate when a cooling or warming cycle has passed through the grain by placing a thermometer in the top 6 – 12 inches of grain. When the grain temperature is about the same as the outside temperature, the cooling or warming zone has passed through the crop and you can turn off the fan. Check the temperature at several loca-

tions to make sure the grain has been uniformly aerated.

The grain should be cooled anytime the average outdoor temperature is about 10 to 15 degrees lower than the grain temperature, until the grain mass has been cooled to 40 to 45F. Run the fans continuously during suitable cold weather (humidity near or below 60 percent) until the total grain mass is cooled. Re-wetting or drying is usually insignificant during aeration. The cooling front moves through the grain much faster than a wetting or drying front, so only a small fraction of the grain is re-wetted during an aeration cycle, even with high humidities. However, if several days

of rainy or foggy weather are predicted, delay aeration until the weather improves.

Grain stored into the spring should be warmed to about 60F. Cold grain in the spring can cause air to condense on the grain and in the bin. Run the fans continuously until the entire grain mass is warmed to 60F. Starting and stopping the fans will cause damp layers to be trapped in the middle. These layers may produce undetectable spoilage.

The best aeration system is one that incorporates a moisture tester and a grain probe. Be sure to make weekly checks of the bins. Never leave a bin unchecked for more than a month. A weekly check will detect hot spots, moisture buildup and insect activity before extensive damage can be caused to the crop. Start aeration fans immediately if any excess moisture or heat buildup is detected, regardless of outside conditions.

Safety

Grain drying and handling can be dangerous. Transport augers can contact power lines, unguarded augers can catch hands or feet and fans and shafts can catch unsuspecting victims. Take precautions when entering a grain bin. Never enter a grain bin while the unloading auger is operating. Moving grain can pull a person below the grain surface in just a matter of seconds. Disconnect power to the unloading auger before entering bins. Always check inside the grain bin before turning on the unloading auger in case someone has entered the bin without your knowledge.

Soybean Marketing

*Originally Prepared by: Charles M. Farmer, Professor Emeritus
Agricultural Economics*

*Revised by: Delton C. Gerloff, Professor
Agricultural Economics*

Soybeans are an integral part of the agricultural economy in Tennessee. They are planted on more acres than any other row crop in the state and rank as one of the top two or three crops each year from the standpoint of cash receipts to producers. Acreage has been rising in recent years. Average yields per acre have also jumped since the early 1990s in response to better varieties, production technology and production skills of growers. In addition, soybeans are being grown on higher average quality land than was the case in the late 1970s and early 1980s, when acreage peaked. For soybeans to make the greatest economic contribution to net farm income, producers should strive to strengthen the total production-management marketing program.

A sound marketing program is important to soybean growers because of what it can do to help manage price risk, reduce anxiety and boost average prices. A solid marketing program can easily add \$.15 – .30/bushel to the season-average price. While this increase may represent only a 2 – 4 percent boost in the average price received, it can easily mean an increase of 10 to 20 percent in net returns to management calculated after all economic costs have been deducted.

Soybean growers also have greater incentive to focus on improved marketing because of greater price volatility in the new deregulated farm policy environment. A reduced role of government in the market will mean greater price fluctuations for program crops and also for soybeans and other non-program crops. A good marketing program can help growers deal with larger price swings.

Soybean Price Trends

Marketing year average soybean prices in Tennessee have ranged from \$4.87 to \$7.96 during the past 20 years. The annual average price was \$6.27/bushel. The average price for the most recent 10-year period is within \$.10/bushel of the first 10 years of this 20-year period, suggesting a sideways price trend over time. It also means that real prices, after adjusting these nominal prices for price inflation, have been declining. Longer-term price projections by some notable research groups suggest

no change in this sideways price trend in nominal soybean prices over the next 5 – 10 years. This projection is based on continued growth in world demand for soybean products but also about equally rapid growth in supply. Projected growth in world supply is tied to further acreage expansion, primarily in South America, and yield gains worldwide based largely on improved plant genetics. If Tennessee soybean producers are to survive and prosper in this general environment, it will require improvement of production efficiency, which leads to lower costs per bushel. Implementation of a program that boosts average prices received within a general market environment, which may well feature sideways-trending prices into the early years of the 21st century, is highly advisable.

Some Ways to Improve Soybean Marketing

This section is not intended to include an exhaustive list of every known influence on soybean prices, but rather in this short chapter to target those areas considered most important.

Develop Better Understanding of Pricing Alternatives

Soybean producers are still price takers when pricing their crop on a particular day, but they can boost their average price by making more effective use of time and available pricing alternatives. The market offers two years or longer to price a particular crop of soybeans. Time can and should be considered as a valuable ally. “Have to” selling should be avoided whenever possible. Growers also have available many pricing alternatives offered through a grain elevator or through a commodity brokerage operation. For an evaluation of the advantages and limitations of the various pricing alternatives, obtain a copy of Extension Publications 1137 – 1140 from your local county Extension office. After learning more about all available soybean pricing alternatives, you can decide which ones are the most practical for you to use. Remember that very little in life thrives on neglect and this is certainly true of soybean marketing.

Place Emphasis on Forward Pricing

The highest new-crop price offers are often provided several months before harvest. New crop price strength during the past 15 years has been greatest during the March – June period. Prices are strongest then because of uncertainty of growing conditions for the new crop. The market, in effect, bids a weather risk premium into prices. In addition, high new-crop prices at or just before the primary planting period in the major growing areas serve as a planting incentive to producers, especially as soybeans, corn and cotton compete for spring-planted acreage. Growers can often use this “acreage bidding” process to good advantage. Many successful soybean marketers have a goal of getting 40 – 50 percent of their expected production priced by July 1. Those with concern about getting too many beans obligated for delivery too early can start with elevator delivery contracts but at some point shift to use of futures or options, where delivery is not required. New-crop prices typically slide during July, based on the failure of serious weather problems to materialize. In effect, most weather premiums tend to be removed during July. Dry weather in late July or August or the fear of early frost can result in the weather premium incorporated back into prices.

Generally, soybean growers can forward price using: (1) fixed price agreements, basis contracts, hedge-to-arrive contract or minimum price contracts with grain elevators; and/or (2) futures market hedges and options contracts through a brokerage firm. Elevator contracts are simpler to use but there is a delivery expectation. Forward pricing through a brokerage business is more complex and has direct monetary consequences, but there are no physical delivery requirements.

Strive to Get More Soybeans Priced in the Upper Part of the Annual Price Range

Many growers target the upper third of the annual price range. To effectively do this, you will need to project the annual price range. Information from USDA and some private firms can be useful. With soybeans, new-crop futures prices usually move to \$7, and often to \$7.40, prior to July 1, unless stocks are excessive. Large crops at harvest often pressure the November futures contract down into the low \$6s. For best results, you should be structuring your new-crop pricing program before planted acreage is known and certainly

before much is known about weather conditions during the growing season.

A grower’s projection of the seasonal price range might be as follows:

Upper bound: \$7.50, November futures, based on historical tendency, bidding between soybeans and corn for land in the March-May period, the possibility of some weather concern and the absence of surplus stocks.

Lower bound: \$6.00, November futures, based on likelihood of rather large acreage, yields near trend level and harvest pressure in October – November. Range: \$1.50 (\$7.50 minus \$6.00)

Upper third of range: \$7.00-7.50 (November futures)

Pricing Soybeans at/after Harvest

Even though you may be aggressive at forward pricing, you will still usually have 30-60 percent of the crop left to price when combines enter fields in the fall. The November futures contract typically makes a seasonal low in the first half of October, or about when harvest is beginning in Tennessee. Growers are therefore generally advised not to make cash sales at harvest the primary feature of their marketing program. Regrettably, the 15 year May soybean futures seasonal price index does not offer much encouragement as far as rapid after harvest price strength. Growers can expect basis improvement (see Extension Publication 1206) of \$.20 – .25 per bushel between October and January, but afterwards, further basis gains are slow to materialize. In contrast, May soybean futures prices often trend sideways between November 1 and late January, before sliding toward a seasonal low in February. Seasonal futures price strength is often impressive during the March – May period.

Many soybean producers in Tennessee use storage or some storage substitute as part of their marketing program. Storage can be an important part of a strong marketing program, but based on price patterns over the 10-15 years, it should not be the dominant part of the marketing program. For more information on economic considerations related to soybean storage, obtain a copy of Extension Publication 1057 at your county Extension office.

Developing a Marketing Plan/Program

A plan will be extremely helpful in assisting a soybean producer in boosting the season average soybean price. Such a plan will be developed around the particular financial needs of a farming operation, after considering such things as seasonal patterns, marketing alternatives and personal preferences of the farm family. The basic goal of the plan is to force the farm operator to plan marketing, rather than to simply sell in an unplanned or emotional manner. Also, the plan, although never in "concrete," can provide some needed discipline.

Once developed, a good plan should to be implemented. Adjustments to the plan are many times necessary if conditions or assumptions on which the plan is based change in a substantial way.

Growers are encouraged to devote at least one

or two hours each week to their soybean marketing program. Those who decide to not make the necessary commitment of time and effort or who believe their management skills will be "stretched too thin" by doing so should consider making use of a marketing service that will get involved in making necessary pricing decisions. For most soybean growers, greater attention to marketing should no longer be considered optional. Just like many other things in life, satisfaction, proficiency and payoff are often directly related to effort expended. Such is true of marketing.

PRECAUTIONARY STATEMENT

In order to protect people and the environment, pesticides should be used safely. This is everyone's responsibility, especially the user. Read and follow label directions carefully before you buy, mix, apply, store or dispose of a pesticide. According to laws regulating pesticides, they must be used only as directed by the label.

Pesticides recommended in this publication were registered for the prescribed uses when printed. Pesticide registrations are continuously being reviewed. Should registration of a recommended pesticide be cancelled, it would no longer be recommended by the University of Tennessee.

Use of trade or brand names in this publication is for clarity and information; it does not imply approval of the product to the exclusion of others which may be of similar, suitable composition, nor does it guarantee or warrant the standard of the product.

Visit the Agricultural Extension Service Web site at:
<http://www.utextension.utk.edu/>

PB1608-1.5M-5/01 (Rev) R12-5210-07-001-01

The Agricultural Extension Service offers its programs to all eligible persons regardless of race, color, national origin, sex, age, disability, religion or veteran status and is an Equal Opportunity Employer.

COOPERATIVE EXTENSION WORK IN AGRICULTURE AND HOME ECONOMICS

The University of Tennessee Institute of Agriculture, U.S. Department of Agriculture,
and county governments cooperating in furtherance of Acts of May 8 and June 30, 1914.

Agricultural Extension Service
Charles L. Norman, Dean