

12-2015

# Analysis of Diffusion in Heat Seals Using Energy Dispersive X-ray Spectroscopy

Mark Hendrickson

Clemson University, [mfhendr@g.clemson.edu](mailto:mfhendr@g.clemson.edu)

Follow this and additional works at: [https://tigerprints.clemson.edu/all\\_theses](https://tigerprints.clemson.edu/all_theses)

---

## Recommended Citation

Hendrickson, Mark, "Analysis of Diffusion in Heat Seals Using Energy Dispersive X-ray Spectroscopy" (2015). *All Theses*. 2278.  
[https://tigerprints.clemson.edu/all\\_theses/2278](https://tigerprints.clemson.edu/all_theses/2278)

This Thesis is brought to you for free and open access by the Theses at TigerPrints. It has been accepted for inclusion in All Theses by an authorized administrator of TigerPrints. For more information, please contact [kokeefe@clemson.edu](mailto:kokeefe@clemson.edu).

ANALYSIS OF DIFFUSION IN HEAT SEALS  
USING ENERGY DISPERSIVE X-RAY SPECTROSCOPY

---

A Thesis  
Presented to  
the Graduate School of  
Clemson University

---

In Partial Fulfillment  
of the Requirements for the Degree  
Master of Science  
Packaging Science

---

by  
Mark Fritz Hendrickson  
December 2015

---

Accepted by:  
Dr. Duncan Darby, Committee Chair  
Dr. Kay Cooksey  
Dr. Patrick Gerard  
Dr. Robert Kimmel

## ABSTRACT

Heat sealing is one of several methods used to weld thermoplastic materials in packaging. Heat seals were made between Dow 501i LDPE and DuPont Nucrel 1202HC poly (ethylene co-methacrylic acid). The seals were exposed to sodium hydroxide solution so that the methacrylic acid sites of the DuPont Nucrel 1202HC were neutralized with a sodium ion. This was done to make diffusion measurements. Two side heated tooling sealing was used to make seals at 40 psi (276kPa), 1.0 second dwell, and temperatures ranging from 200°F (93.3°C) to 300°F (148.9°C). Energy dispersive x-ray spectroscopy, a function of scanning electron microscopy, was used to measure the presence of sodium and therefore diffusion of the methacrylic acid sites. The methacrylic sites are part of the polymer chain, and were tagged from the sodium hydroxide. It was possible to estimate polymer chain diffusion distance based on a sodium trace, as well as an oxygen trace.

Then this method was used to measure diffusion on samples of 501i and 1202HC sealed at various temperatures. Diffusion was compared to seal temperature and to seal strength. The results of this study are different from previous findings. It was found that with this system diffusion distance is not correlated to seal strength. It was also found that for this system diffusion distance is not correlated with sealing temperature. However, it was found that both sodium and oxygen can be used to estimate diffusion in this polymer system.

## ACKNOWLEDGMENTS

I would like to thank Dr. Duncan Darby, Dr. Kay Cooksey, Dr. Patrick Gerard, and Dr. Robert Kimmel for being on my committee. Their assistance and guidance was highly valuable in this work. Pat Marcondes, Bob Bennet, and Jerry Stoner were great to work with throughout this research. Their teaching and experience helped lead me to success.

Dr. Barry Morris at DuPont supplied me with Nucrel and ideas. Both proved to be essential in the completion of this work.

My parents supported me through my decision to research. Their guidance and assistance made it possible to complete this work.

Robyn Manhard has been more than understanding throughout this experience. Her support means more to me than I can express.

## TABLE OF CONTENTS

	Page
TITLE PAGE.....	i
ABSTRACT .....	ii
ACKNOWLEDGMENTS .....	iii
LIST OF TABLES.....	vi
LIST OF EQUATIONS .....	vii
LIST OF FIGURES.....	viii
1. INTRODUCTION .....	1
2. LITERATURE SEARCH.....	3
3. OVERVIEW OF SEALING TECHNOLOGIES .....	7
Time.....	8
Pressure.....	10
Energy.....	11
Types of Sealing .....	19
4. OVERVIEW OF SCANNING ELECTRON MICROSCOPY.....	28
5. MATERIALS AND METHODS.....	38
Dow 501i LDPE .....	38
Nucrel® 1202HC .....	40
Sealing Samples .....	42
Sample Prep for Instron T10000 with 500lb Load Cell .....	46
Satec Instron Testing.....	50
Differential Scanning Calorimetry (DSC) Analysis .....	54
Sample Prep for Scanning Electron Microscopy (SEM) .....	55
Tagging the Nucrel® with Sodium Ions.....	56
Mounting Samples on Conductive Hardware for SEM.....	59
The Scanning Electron Microscope .....	62
Analysis of Line Scan Data with SAS® Program.....	63
Analysis of Diffusion Data in Excel 2013.....	64
Calculations Related to Electron Beam Interactions.....	65

Table of Contents (Continued)

	Page
Initial Materials and Methods.....	66
6. RESULTS.....	67
Thickness Profiles.....	68
Seal Curves.....	70
DSC Curves.....	73
Electron Microscope Results .....	78
EDX Resolution and Depth of Penetration .....	89
Diffusion Analysis .....	91
Revisit of 220°F Sealing Temperature with Paired Samples.....	100
Potential Reasons Which Caused Unexpected Data .....	102
7. CONCLUSIONS.....	104
8. RECOMMENDATIONS FOR FUTURE WORK.....	105
9. APPENDIX.....	107
Materials and Methods Idea One .....	107
Materials and Methods Idea Two .....	109
Materials and Methods Idea Three.....	109
Materials and Methods Idea Four.....	110
Final Materials and Methods.....	111
Material Data Sheets.....	112
SAS® Program .....	118
10. WORKS CITED.....	119

## LIST OF TABLES

	Page
Table 1: 501i LDPE Extrusion Settings .....	38
Table 2: Nucrel® 1202HC Extrusion Settings .....	40
Table 3: Line Scan Data Collection Settings .....	63
Table 4: SEM Data Collection Settings.....	63

## LIST OF EQUATIONS

	Page
Equation 1: Area of a Symmetric Lens .....	34
Equation 2: Depth of Penetration Estimation in EDX.....	65
Equation 3: Spatial Resolution Estimation in EDX.....	66
Equation 4: Anderson-Hasler X-Ray Range.....	90



## LIST OF FIGURES

	Page
Figure 1: Diffusion at the Seal Interface.....	7
Figure 2: Simplified Representation of a Vertical Form, Fill, and Seal System (Emblem & Emblem, 2012) .....	9
Figure 3: Seal Sample in the Jaws of the Satec Instron .....	16
Figure 4: Example of a Peel Seal Curve .....	17
Figure 5: Example of a Fusion Seal Curve.....	18
Figure 6: Diagram Representing External Heating.....	20
Figure 7: Diagram Representing Internal Heating .....	20
Figure 8: Comparison of LM to SEM, (Australian Centre for Microscopy & Microanalysis, 2014) 29	
Figure 9: Origin of Detectable Electrons and X-rays after Interaction with Electron Beam (Hafner, 2015) .....	32
Figure 10: Visualization of a Symmetric Lens, (Wolfram Alpha LLC, 2015) .....	35
Figure 11: Spatial Resolution Visualization to Scale.....	35
Figure 12: Electron Shell Ionization Nomenclature, (Woldseth, 1973).....	36
Figure 13: The Killion Cast Film Extruder.....	39
Figure 14: The Chill Roll, Nip Roll, and Rewinder.....	39

List of Figures (Continued)

	Page
Figure 15: Sentinel Lab Scale Heat Sealer.....	43
Figure 16: The Digi-Sense JTEK Thermocouple.....	44
Figure 17: The Thermocouple Leads from the Top and Bottom Seal Jaws .....	44
Figure 18: Sealed Structure to Scale .....	46
Figure 19: Seal Sample before Modification.....	48
Figure 20: Seal Sample with One Side Taped .....	48
Figure 21: Seal Sample with Two Sides Taped.....	49
Figure 22: Taped Seal Sample in Cutter before Cutting .....	49
Figure 23: Taped Seal Sample in Cutter after Sizing to 2.54cm (1.00") .....	50
Figure 24: The Satec Instron when set to a 0.5" Jaw Opening .....	52
Figure 25: A Seal Sample Ready to be Pulled in the Satec Instron Jaws .....	53
Figure 26: A Seal Sample While it is Being Pulled .....	54
Figure 27: Example of a Good Shatter (Left) and a Bad Shatter (Right).....	56
Figure 28: Poly (ethylene-co-methacrylic acid) <a href="http://www.sigmaaldrich.com/catalog/product/aldrich/426628?lang=en&amp;region=US">http://www.sigmaaldrich.com/catalog/product/aldrich/426628?lang=en&amp;region=US</a> .....	58
Figure 29: Chemical Structure of Poly (ethylene-co-methacrylic acid) after reaction with NaOH	59

List of Figures (Continued)

	Page
Figure 30: Seal Samples in a Petri Dish Soaking in NaOH.....	59
Figure 31: Polymer Sample Mounted Between Half Moon Discs for SEM.....	61
Figure 32: Samples Mounted on Multi-Holder .....	61
Figure 33: The Group of Machinery Utilizing the SEM and X-ray Detector .....	62
Figure 34: Thickness Profile of 501i LDPE Used in Study.....	68
Figure 35: Thickness Profile of Nucrel® 1202HC Used in Study .....	69
Figure 36: Seal Curve Results of Nucrel® 1202HC Poly(ethylene-co-methacrylic acid) Sealed to Dow 501i LDPE .....	70
Figure 37: Averaged, with Error Bars, Seal Curve Results of Nucrel® 1202HC Poly(ethylene-co-methacrylic acid) Sealed to Dow 501i LDPE .....	71
Figure 38: Seal Curve Results in Fahrenheit Adjusted by Mode of Failure, Averaged, with One Standard Deviation Error Bars .....	72
Figure 39: Differential Scanning Calorimetry Result from Dow 501i LDPE.....	73
Figure 40: Differential Scanning Calorimetry Result from DuPont 1202HC Poly(ethylene-co-methacrylic acid).....	74
Figure 41: Differential Scanning Calorimetry Overlay of Nucrel® 1202HC and 501i LDPE First Heating and First Cooling .....	76
Figure 42: Differential Scanning Calorimetry Overlay of Nucrel® 1202HC and 501i LDPE First Cooling and Second Heating.....	77

List of Figures (Continued)

	Page
Figure 43: Energy Dispersive X-Ray Analysis Line Scan Result, Sodium Scan .....	78
Figure 44: Annotations made before Line Scan.....	79
Figure 45: Line Scan Data with Diffusion Beginning and Ending Marked in Red .....	80
Figure 46: Sodium Tagged Seal Interface .....	81
Figure 47: SEM Image of the Surface of Dow 501i LDPE Not Exposed to NaOH .....	82
Figure 48: Result of Area Scan of Spectrum 3 in Figure 47 .....	83
Figure 49: SEM Image of the Surface of Dow 501i LDPE Exposed to NaOH.....	84
Figure 50: Result of Area Scan of Spectrum 7 in Figure 49 .....	85
Figure 51: SEM Image of the Surface of DuPont Nucrel® 1202HC Not Exposed to NaOH .....	86
Figure 52: Result of Area Scan of Spectrum 11 in Figure 51.....	87
Figure 53: SEM Image of the Surface of DuPont Nucrel® 1202HC Exposed to NaOH.....	88
Figure 54: Result of Area Scan of Spectrum 2 in Figure 53 .....	89
Figure 55: Average Sodium Based Diffusion Distance vs. Seal Temperature .....	91
Figure 56: Raw Oxygen Based Diffusion Trace.....	93
Figure 57: Average Oxygen Based Diffusion Distance vs. Seal Temperature .....	94
Figure 58: Sodium and Oxygen Based Diffusion Distance vs. Seal Temperature .....	95

List of Figures (Continued)

	Page
Figure 59: Correlation of Oxygen and Sodium Diffusion Distances by Seal Temperature .....	96
Figure 60: Seal Strength vs. Average Sodium Based Diffusion Distance .....	97
Figure 61: Seal Strength vs. Average Oxygen Based Diffusion Distance .....	98
Figure 62: Seal Strength vs. Average Sodium Based and Oxygen Based Diffusion Distance.....	99
Figure 63: Sodium Based Trace of Diffusion Distance at 220°F Seal Temperature, Using Paired Samples .....	100
Figure 64: Oxygen Based Trace of Diffusion Distance at 220°F Seal Temperature, Using Paired Samples .....	101
Figure 65: Specification Sheet, DuPont 1202HC, Page 1 of 3 (DuPont, 2014).....	112
Figure 66: Specification Sheet, DuPont 1202HC, Page 2 of 3 (DuPont, 2014).....	113
Figure 67: Specification Sheet, DuPont 1202HC, Page 3 of 3 (DuPont, 2014).....	114
Figure 68: Specification Sheet, Dow 501i LDPE, Page 1 of 3 (The Dow Chemical Company, 2015) .....	115
Figure 69: Specification Sheet, Dow 501i LDPE, Page 2 of 3 (The Dow Chemical Company, 2015) .....	116
Figure 70: Specification Sheet, Dow 501i LDPE, Page 3 of 3 (The Dow Chemical Company, 2015) .....	117

## INTRODUCTION

Plastics are a versatile type of packaging which are new to the market as of the last 100 years. Depending on the physical properties and chemical structure, plastics can be rigid or flexible, clear or opaque, a good barrier or a poor barrier. A commonly used type of flexible packaging is film. In order for this film to become a useful package, it needs to assume some sort of form. One way to form plastic films is the heat seal.

One way that packaging experts classify seals is into categories of fusion seals and peelable seals. Fusion seals are stronger than the sum of their parts, the materials making the fusion seal will break before the seal does. Peelable seals are designed to come apart before the material does. Many seal structures can be made into either peelable seals or fusion seals depending on the process conditions.

An area of interest is diffusion at the seal interface. The seal interface is the area of the seal where the polymers are brought into contact. When the sealable polymer system is homogeneous, the seal interface should be indistinguishable from the bulk. If the polymers in a seal are chosen carefully, then it may be possible to quantify the diffusion or mixing at the seal interface. Since many polymer types used in packaging are chemically similar to each other, choosing a polymer system which is similar enough to seal yet is dissimilar enough to be differentiated is challenging. This choice becomes even more important since polymer diffusion at the seal interface is estimated to be less than 10 microns. If this diffusion distance could be reliably quantified, then it may be possible to correlate seal strength and seal temperature.

A previous study done by (Cooper, 2014) showed that the diffusion distance at the seal interface could be reliably quantified. These data were correlated to seal strength and seal

temperature. The current research sought to address several of the questions left unanswered at the conclusion of the previous research.

There were five primary goals of this research. The first goal was to further the understanding of heat sealing. The second goal was to eliminate the possibility of ion hopping. Ion hopping is a phenomenon which may occur when sealing ionomers. In such systems, the ionic bonds may dissociate during sealing, allowing the ions to “hop” from one polymer chain to another. The third goal was to eliminate the possibility of material extension during seal testing. The fourth goal was to explain the transition from peelable to fusion seal with diffusion based data. The fifth goal was to improve the scanning electron microscope technique for examining non-conductive, low density samples like polymers. All but one of the goals was accomplished, the fourth goal. The polymer system was not compatible enough to form fusion seals, so no transition from peelable to fusion seals could be studied.

## LITERATURE SEARCH

It is likely that packaging has been used since humans began to use tools. It has been hypothesized that the first package used was a wrapping of leaves (Emblem & Emblem, 2012). When the need to store larger quantities of food came about after the rise of agriculture, clay jars began to appear. Clay jars or clay pots have been dated to 8,000 B.C. Glass packaging was developed several millennia later, around 1,500 B.C. Packaging, until the industrial revolution, was based on the bulk storage of goods, as the predominant lifestyle of the time was farming. During the industrial revolution, people began to move into cities where space was limited. A shift began towards smaller packages. Rather than the consumer bringing large quantities of goods to their home, the consumer would take a container to the store where it would be filled by the store keeper. When this method became too cumbersome for the consumer, the stores began to pre-package goods for the convenience of the consumer. When pre-packaging goods became too cumbersome for the store, items were packaged at their point of production. Brand names began to develop after items were packaged at the point of production (Emblem & Emblem, 2012).

Shifts in consumer behavior prompted changes to packaging in the mid to late 1900's. The average family size declined, leading to smaller food packages (Emblem & Emblem, 2012). Single parent households, and households where both parents worked led to the development of foods which could be ready to eat quickly. Freezers and refrigerators became common in the home, so food could be preserved longer. Microwave ovens were developed, which opened a market for microwave safe packaging. A smaller portion of total income was spent on food in the United States in the mid to late 1900's than in previous centuries, allowing for some luxury



food purchases. It became common to manufacture or produce goods internationally. Internationally produced products need to survive distribution through a more complex supply chain. As the population began to live longer, a market sector was created with easy open features in mind. The proliferation of the modern supermarket led to a need for product differentiation. Finally, there was a move from rigid glass or rigid metal containers to flexible plastic or rigid plastic containers (Emblem & Emblem, 2012).

The accumulation of these changes during the mid to late 1900's necessitated that the modern package perform many functions. The modern package must contain, protect, preserve, provide convenience, inform, and be designed for a specific point of sale (Soroka, 2009).

The function of containment means that the product must stay in the package until the intended end user interacts with the product. The product must not come out of the package until it is intended to do so. Product spills can have economic and environmental costs. Product leaking from the package can also pose a food safety hazard. The severity of cost associated with a leaking product depends on the product, but it is best practice to avoid leaking containers.

The package must protect the product from a variety of hazards from the point of origin to the point of use by the consumer. The product should arrive to the consumer in an undamaged condition. Protection can be required from one or a combination of: shock, vibration, compression, changing atmospheric conditions, exposure to light, pests, theft, and various other hazards.

Preservation provides the function of extending the shelf life of the product. A well-designed preservation technique allows the product to withstand a longer (less expensive) distribution cycle, as well as allowing the consumer to keep the product longer after purchase. An example of a well-designed preservation technique is a bag of potato chips. Exposed to light or oxygen, potato chips will go rancid in a matter of days. However, when the light blocking and low oxygen permeability potato chip package is filled with potato chips and nitrogen, the potato chips can stay fresh over several weeks.

Packaging needs to provide the consumer with convenience. For the consumer, it is convenient to have an easy open container, closing feature, portion control, and microwavable products. It is also convenient to have a package designed for dispensing the product it is intended to contain. Both the physical form (liquid, solid, gas, paste) and the nature of the product (sticky, fragile, perishable) must be considered when choosing the dispensing mechanism of a package (Soroka, 2009).

It is essential the package provides the consumer with information. The consumer needs to know nutrition facts, usage instructions, and what the package contains. Before the product reaches the consumer, anyone handling the package needs to know the identity of the item inside the package, any special handling considerations, or how to put the product on display. The producer should also put information on the package to track it if there are any issues with a particular product, or if a product recall needs to be initiated.

The modern package must sell itself on the store shelf. The package needs to be well designed and correctly labeled. The package also must arrive at the point of sale (or directly to the consumer in the case of online shopping) in an acceptable condition. A modern consumer is

faced with a myriad of choices; part of the decision of what product to buy is based on the packaging (Hurley, 2014).

Many packages employ flexible packaging, which is often made from thermoplastic materials. One of the ways to seal a flexible package is with a heat seal, or other energy based seal which causes a seal interface to be created. Heat sealing is a process which only works with thermoplastic materials. Thermoplastic materials become fluid with the addition of energy (Soroka, 2009). These materials can undergo the process of softening and hardening many times. This process allows for the repeated use of the same polymer, such as when a film is made and then sealed. Both the making of a thermoplastic film and the sealing of a thermoplastic film require the plastic to soften and harden.

Thermoset materials are different from thermoplastic materials in that they cannot be shaped more than once (Soroka, 2009). The polymerization process of thermoset materials can be brought on by the mixing of two components, the addition of heat energy, or exposure to a high energy source (such as an electron beam or an ultraviolet light source). Thermoset polymers cannot be heat sealed, but they offer the advantage of high chemical and heat resistance when compared to thermoplastic materials (Soroka, 2009).

## OVERVIEW OF SEALING TECHNOLOGIES

A seal is a method of closing a package using the flow and adhesion/cohesion properties of at least one plastic material (Darby, 2015). A seal is a type of polymer welding. If a seal is made with thermoplastic materials (a heat seal), energy needs to be applied to the seal interface. Cold seals, such as those used for chocolate bars, do not require energy to be added to the system for a weld.

When a seal between two polymers is made, the polymers are welded together at the polymer seal interface. The polymers diffuse into each other partially because of energy added into the system. A simplified diagram of diffusion at the seal interface is shown in Figure 1.

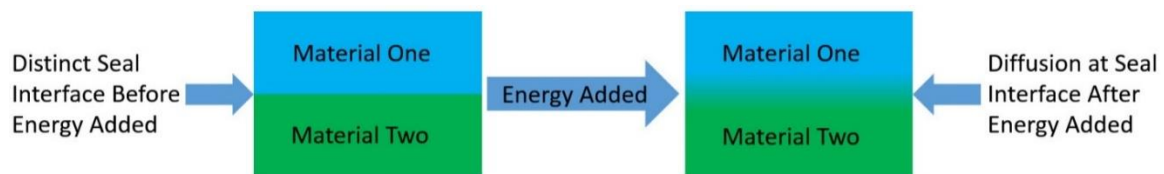

*Figure 1: Diffusion at the Seal Interface*

The reason to seal packages is to enable the package to perform its function to contain, protect, transport, inform, and dispense (Soroka, 2009). Most flexible and semi-rigid packages employ some type of seal. Examples of packages where seals are used include: lidding, blister packs, shrink wraps, flow wraps, bags, stand up pouches, stick packs, pillow pouches, four side seal pouches, retort pouches, tubes, and skin packaging.

There are many polymers used for heat sealing. Heat seals are often made between two surfaces of the same polymer. Dissimilar polymer heat seal compatibility is limited. Some of the many polymers which are used in a heat sealing process include: high density polyethylene (HDPE), low density polyethylene (LDPE), linear low density polyethylene (LLDPE), polypropylene (PP), oriented polypropylene (OPP), polystyrene (PS), polyethylene terephthalate

(PET), amorphous polyethylene terephthalate (APET), ethylene acrylic acid (EAA), ethylene methacrylic acid (EMAA), ethylene vinyl alcohol (EVA), and Ionomer (Darby, 2015).

Different polymers are chosen for their various material and processing characteristics. For example, PP, with its high melting point, is often chosen as the sealant layer in retort pouch structures because of the high temperatures in the retort chamber. Retort is a process which uses high temperature to sterilize the product contained in the package (Soroka, 2009).

In order to make a heat seal, there are three variables which are considered in most systems: time, pressure, and energy. Time is dependent upon the rate determining step in the process. The slower the process, the longer the cycle time of the machine. Pressure is required for intimate contact between the sealing surfaces. Without adequate pressure, the sealing surfaces (which are rough on a microscopic scale) would not be in intimate contact. Energy is often supplied as heat. However, heat is not the only form of energy which can set the chains of a polymer into motion to form a seal.

To define the strength of a seal, a test is performed. A seal strength test is when a known width of a seal is tested for strength using a programmable mechanical separation method with a load cell.

### **Time**

Time is of importance in a converting operation. The shorter the time required for a seal, the higher the potential productivity of a given piece of equipment. Cycle time is often not as fast as desired because of the mechanical motion of the machine, the thermal resistance of the polymer being sealed, and any hot tack requirements of the system.

Hot tack is a measure of seal strength just after the seal has been made. If the hot tack is too low, then the speed of a machine must be reduced until the fresh seal can withstand the

next step in processing. Hot tack is especially important in systems where a product “lands” on the seal just after the seal is made. One such system is a vertical form fill and seal (VFFS) machine as shown in Figure 2. A form, fill, and seal process is a type of packaging process where the package is formed, filled, and sealed in one machine (Emblem & Emblem, 2012). The packaging material is supplied as a formable web on a roll. The machine is described as a VFFS machine if the forming, filling, and sealing process happens in a top down orientation.

In quick succession, the seal is made between the seal jaws (item 7) then the product drops down the filling tube (item 4) onto the still warm seal. With inadequate hot tack, the seal would break and productivity would be lost.

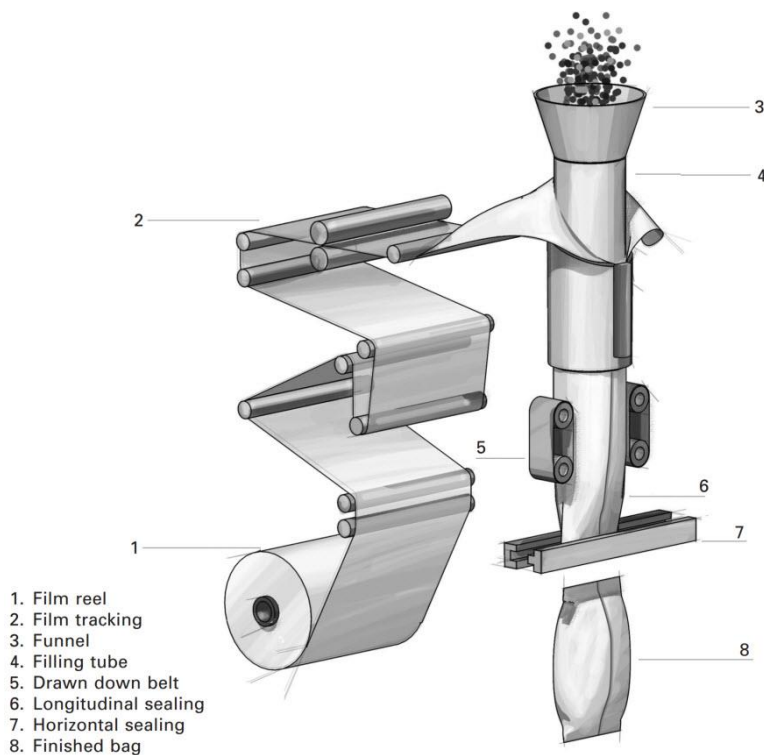

Figure 2: Simplified Representation of a Vertical Form, Fill, and Seal System (Emblem & Emblem, 2012)

Time is also required for polymer flow to occur. Simply heating the seal interface to an appropriate sealing temperature is often not enough; the seal interface needs to be held under pressure for polymer flow to occur. When the seal interface is given adequate energy, the sealable polymer becomes liquid. A liquid under pressure will flow. If the two polymers are miscible (soluble) in each other, they typically form a seal.

An important consideration related to sealing time is the chain length of the polymers being sealed. A polymer chain is a molecule within monomeric components linked together. Polymeric chains can be several thousand monomers in length (Soroka, 2009). The polymer chains which make up a free radical polymerized polymer, such as low density polyethylene (LDPE), vary in length. Because of energetic considerations nature tends to have the short chains of the polymer at the surface and the longer chains of the polymer in the bulk of the polymer. The reason that short chains are at the surface of the polymer is because of entropy and enthalpy. Enthalpy “seeks” to be low, as it is the sum of internal energy of a system. Entropy “seeks” to be high, as it is a measure of disorder. Having the short chains near the surface lowers enthalpy and raises entropy (Qureshi, Stepanov, Capaccio, Hiltner, & Baer, 2001). In order to form a strong seal, the long chains in the bulk of the polymer may need to diffuse through the short chains at the surface of the polymer and into the seal interface.

### **Pressure**

Pressure is the second variable required for a heat seal. Pressure during a seal causes an intimate contact between the sealant surfaces, and often intimate contact between the sealing jaws and the polymer. Some literature indicates there is no relation between pressure used to make the seal and seal strength (Theller, 1989). However, there is also evidence that there is a correlation between seal strength and the pressure used to make the seal

(Najarzadeh, 2014). The evidence points to a minimum necessary pressure needed to make the seal. After the minimum pressure has been achieved there is minimal dependence of the seal strength on pressure (Najarzadeh, 2014). In a manufacturing setting, pressure can also be important to achieve seals in the presence of film thickness inconsistencies

### **Energy**

Energy, often heat, is another parameter in the heat sealing process. Thermal energy can be supplied to the seal interface externally or internally. An external supply of energy is from a heated platen, or a heated sealing jaw. Internally supplied energy is energy which has been supplied directly to the seal interface by mechanical means or an electromagnetic wave. An important consideration in external energy supply is the size of the heated sealing jaw. If the jaw is too small, then it will not be able to store enough heat to operate expeditiously. Unless mentioned otherwise, the sealer being discussed is a two side heated tool sealer with the option to adjust the dwell time, the temperature of the tool (also called the seal jaw), and the pressure at which the seal is made. Dwell time is the amount of time that energy is delivered to the polymer interface.

There are three main types of seals which can be made when heat sealing (Darby, 2015). They are: mechanical, chain entanglement, and intermolecular. A mechanical seal is a physical bond. A mechanical seal can also be made between two non-polymeric materials. A chain entanglement seal is made between two polymer materials when both materials are miscible in each other. An intermolecular seal is a type of bond which is chemical in nature, specifically secondary molecular bonds (Darby, 2015). No chain entanglement occurs in an intermolecular seal.



A mechanical seal is a physical bond between a porous material and a material which will flow (Darby, 2015). An example is a polymer sealed to a porous paper. The polymer, while molten, flows into the pores of the paper. When the polymer hardens after the energy source is removed from the system, the polymer is sealed to the paper by being stuck within the pores of the paper. Another type of mechanical seal is made with two layers of paper. Paper drinking straw wrappings are sealed mechanically without the use of heat. Mechanical seals can also occur between a non-woven polymeric material and a polymeric material if the melting points are sufficiently different. The molten polymer flows into the pores of the non-woven material just as it flows into the pores of a paper. It is advantageous to have a porous material sealed to a non-porous material in the case of ethylene oxide gas sterilizable medical packaging. In the case of sterilizable medical packaging, the ethylene oxide gas needs to pass into the package through the permeable layer before sterilization can occur. The ethylene oxide gas is then removed before the packaging is handled (STERIS Isomedix Services, 2015).

A chain entanglement bond is common when heat sealing. This occurs when the polymers in both interfaces are miscible in each other, and the polymer chains from the two layers become entangled across the seal interface. Chain entanglement means the polymer chains from one polymer in the system crossed into another polymer in the system (Si, Massa, Dalnoki-Veress, Brown, & Jones, 2005). When the chains at the surface of one polymer achieve a high enough energy state, they can move around and interact with the chains at the surface of the other polymer in the system. To achieve miscibility, it is best if the polymers being sealed together are the same. However, in some cases, the polymers do not have to be completely identical. For example, when one polymer is LDPE and the other polymer is a copolymer of

88.5% LDPE and 11.5% methacrylic acid it is thought that the chains entangle. This specific example will be discussed at length in the following sections.

When a chain entanglement seal is being made under pressure, air and other contaminants can be pushed out of the seal area. After the energy source is taken out of the system, the newly entangled chains cool in an entangled state. This causes a bond to form. The bond can be either a peelable seal or a fusion seal. In the case of a peelable seal, only limited entanglement has occurred, and the material is stronger than the seal. In the case of a fusion seal, more entanglement has occurred, and the seal is stronger than the materials of which it is made.

Intermolecular bonding is another type of bonding possible when sealing. This is a secondary chemical bond made under heated conditions. A specific example of this type of bond is polyethylene co-ethylene acrylic acid (EAA) sealed to aluminum foil. The aluminum foil cannot flow at temperatures accessible to polymer processing nor is it porous, so a mechanical seal is impossible. The bond in this case is caused by intermolecular forces. This type of bond isn't particularly strong; however, it can be advantageous because no adhesive is required to bond a polymeric material to another surface. It can also be advantageous for peelability.

Application of heat transfer theory helps to determine the amount of time it takes to raise the temperature of the polymer to the point where it can achieve a bond (Darby, 2015). Some heat transfer models are limited by the assumptions necessary to make the related equations solvable with calculus. Some of these assumptions include a constant heat capacity through a phase change, and that no energy is released during crystallization. Another assumption made in some models is that the polymer system is comprised of one layer when, in fact, many polymer systems have other layers besides the sealant layer. Even though models

are limited by assumptions, the equations can still provide useful insight. One of the insights which models bring is that the seal interface in a heat sealer with two heated plates will reach an equilibrium temperature much faster than the same polymer system in heat sealer with one heated plate (Darby, 2015).

Heat transfer models also helps to explain why a seal cools more slowly than it is heated. This is important to understand because hot tack is often a limiting factor in machine speed. If the hot tack strength is too low, then the machine needs to be run more slowly until the seal strength is high enough to run appropriately. The most common reason that the seal cools more slowly than it heats is because it is in direct contact (conduction) with the heated seal bars when it is heating, but it is in contact with air when it is cooling (convection).

When a chain entanglement seal or mechanical adhesion seal has occurred, there are two main types of seals which can occur. One is a fusion seal. The fusion seal is a strong seal which, in a package, is designed to stay sealed. The second type of seal is a peelable seal. The peelable seal is designed to open when incorporated into a package, and is sometimes part of an easy open feature.

Fusion seals are strong seals; the strength of the seal is often stronger than the strength of the material. When a seal strength test is performed on a fusion seal, the material will likely break before the seal breaks. A fusion seal, when used in consumer packaging, often requires some type of opening feature. Opening features which are common to packages with a fusion seal are notched tear initiation points, tear strips, and zippers. A fusion seal is desired in retort packages. A fusion seal is also desired in hot fill packages. Hot filling is a filling technique that keeps the product at temperatures up to 212°F to maintain sterility in a range of products (Soroka, 2009). The package into which the product is hot filled can be sterilized by the heat of

the product. Another use of fusion seals is tamper evidence. When a package sealed by a fusion seal is opened, it readily evident that the package has been opened.

Peelable seals are weaker than fusion seals. Peelable seals are designed to open. When a seal strength test is performed on a peelable seal, the seal will somehow break before the material breaks. Peelable seals are common on flexible lid on rigid cup packages, senior friendly packages, and other easy open items. Peelable seals can fail in a number of ways. An adhesive split is a failure which is clean in appearance where the sealant separates from the surface to which it was sealed. A cohesive failure leaves residue behind when the sealant layer breaks internally.

When the seal strength is tested, the strength is usually measured by a relatively simple device with a load cell. The device has means with which to hold the two “legs” of the seal sample. An example of a jaw system holding a polymer sample is shown in Figure 3. Once the sample is in place, the machine pulls the “legs” of the sample apart at a constant speed. The machine has a load cell to record the force it encounters while pulling the sample apart. This machine can then relate the force the load cell recorded to the relative position of the seal jaws. This is the basis of a seal testing machine.

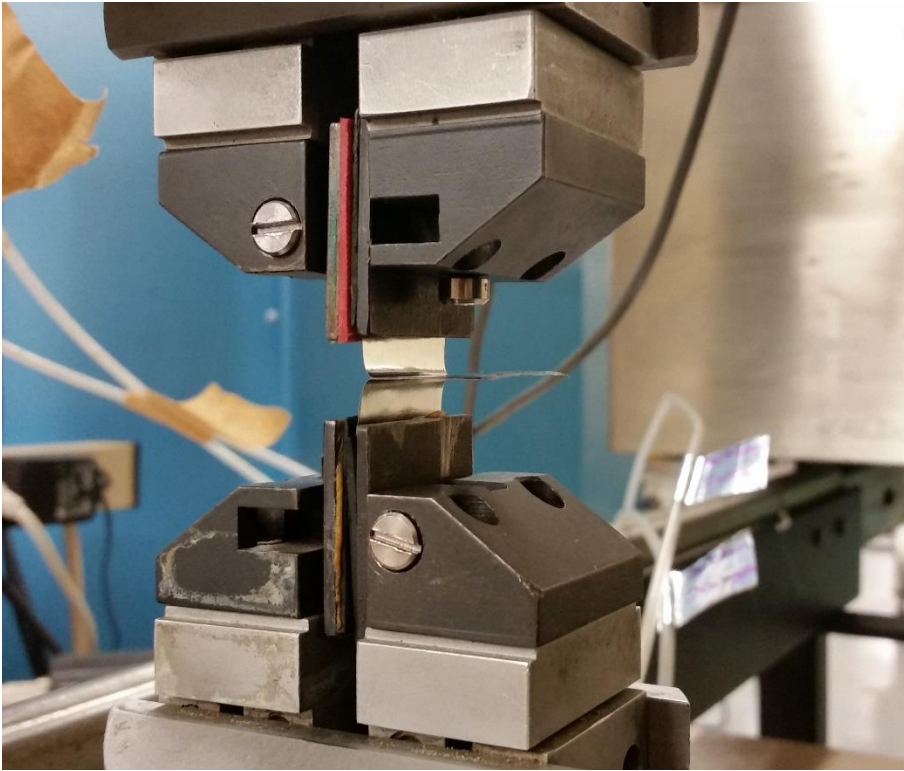

*Figure 3: Seal Sample in the Jaws of the Satec Instron*

When a seal test is performed, it is testing both the strength of the material making the seal and the seal itself. If an attempt to isolate the seal is made by laminating the structure to a relatively inextensible layer, then the strength of the seal will measure higher (Darby, 2015). This will be discussed later in detail.

A seal initiation peak is often present when a seal test is performed on a peelable seal interface. A seal initiation peak is visible in Figure 4 from approximately 0.05 inches to 0.11 inches of seal extension. The maximum of the seal initiation peak is marked by a triangle. A seal end peak is also sometimes present in a seal curve result, which is visible in Figure 4 from approximately 0.36 inches to 0.40 inches of seal extension. The top of the seal end peak is marked by a triangle. This can be due to a number of reasons. One reason is that it often takes more energy to initiate a tear than it takes to propagate a tear. Another potential reason that a

seal initiation peak is present in many seal curves is that the initial seal area could be thicker due to squeeze out. When the seal is formed, the polymer in the seal area is a liquid under pressure. A liquid under pressure flows, and can cause a thicker area to form at the edge of a seal interface.

Seal tests are performed because seal strengths vary with sealer conditions. Energy applied to the seal, the time the energy was applied to the seal, and the pressure at which the energy was applied will change the strength of a seal. The failure mode of a seal will also often change with conditions. When a fusion seal is measured, the maximum strength is the strength recorded for the seal curve as shown in Figure 5. The small triangle at the top of the curve at approximately 0.21 inches of peel extension represents the maximum recorded strength for the seal. When a peelable seal is measured, the average sustained seal strength is measured as shown in Figure 4. The seal strength was determined to be flat from approximately 0.11 inches to 0.36 inches. The seal initiation peak is sometimes ignored in the case of a peelable seal.

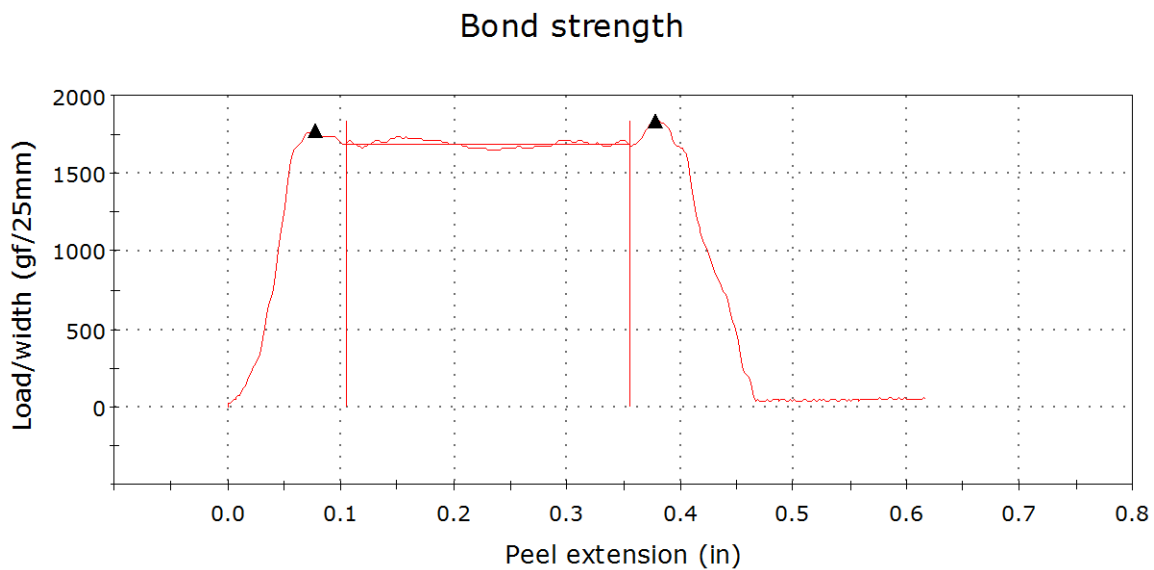

Figure 4: Example of a Peel Seal Curve

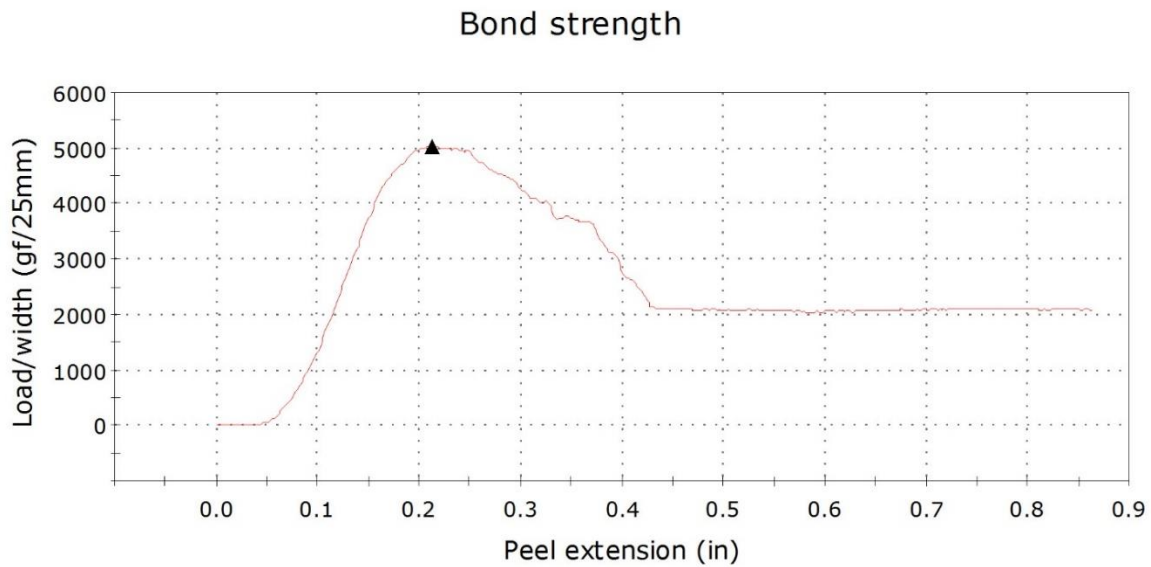

Figure 5: Example of a Fusion Seal Curve

There are three main types of seal curves when dealing with heated tool sealing (Darby, 2015). Seal strength vs. Temperature is the most common seal curve. This curve is used to answer the question of how seal strength varies with changes in sealing temperature. Seal strength vs. Time is another less common seal curve. This seal curve can be used to answer the question of how quickly a seal of appropriate strength can be made. Seal strength vs. pressure curves are also less common. However, they can be useful to find the minimum pressure required for an acceptable seal.

Transferring the data from a seal curve made in the laboratory into a manufacturing environment can be a challenge. Lab scale sealers behave differently than sealers on the manufacturing floor. A specific example is how the dwell is timed. There are two ways to measure dwell. The first, and less desirable way, is additive. The time it takes for the seal bar to move from its home position to the polymer being sealed, the time of dwell at the seal, and the time it takes for the seal bar to move back to the home position are added to make the “seal”

time. The second way is for the dwell to be timed is to neglect platen travel time and to measure the time the platen is in contact with the material to be sealed. The sealer is able to time how long the seal bar is in contact with the polymer. The second way is a more reliable measure since it is more consistent from machine to machine.

Other challenges arise when applying seal curve data from a lab sealer to a manufacturing process. Temperature control can be an issue. It is not likely the manufacturing machine and the lab equipment have the same quality of temperature control. Pressure control can be another issue. It is easier to troubleshoot a lab scale sealer than it is to troubleshoot an entire packaging machine.

### **Types of sealing**

The discussion of methods to seal polymer films will be broken up into two sections. The first section will deal with external heating of the seal interface. External heating is when energy is supplied to the seal interface externally by direct or indirect contact. The entire structure being sealed is often heated as a result. Figure 6: Diagram Representing External Heating is a representative diagram of external heating. The structure between the heated jaws is a structure of research interest. The 1.00 mil PET is a 1/1000" thick polyethylene terephthalate film. The 2.74 mil Nucrel is a cast film that is a copolymer of polyethylene and methacrylic acid. The 2.57 mil LDPE (low density polyethylene) is a cast film. The zoom view on the right side of Figure 6 is an expanded view of the seal interface. The seal interface of the 2.74 mil Nucrel has diffused into the seal interface of the 2.54 mil LDPE.

The second section will deal with internal heating of the seal interface. Internal heating is when the energy required for the seal is delivered directly to the seal interface. Figure 7 is a representative diagram of internal heating. The structure between the jaws is the same as the



structure in Figure 6. The small arrows in the zoom view represent the microscopic motion of the polymer interface when energy is applied. With enough motion, heat is developed from friction. With enough heat, the seal interface of the 2.74 mil Nucrel will diffuse into the seal interface of the 2.54 mil LDPE.

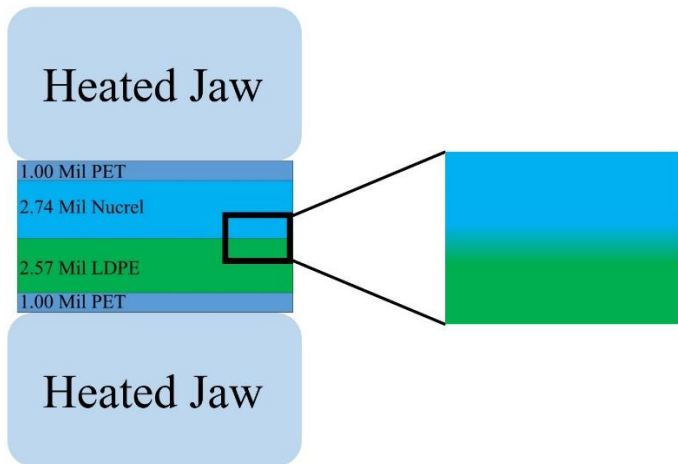

Figure 6: Diagram Representing External Heating

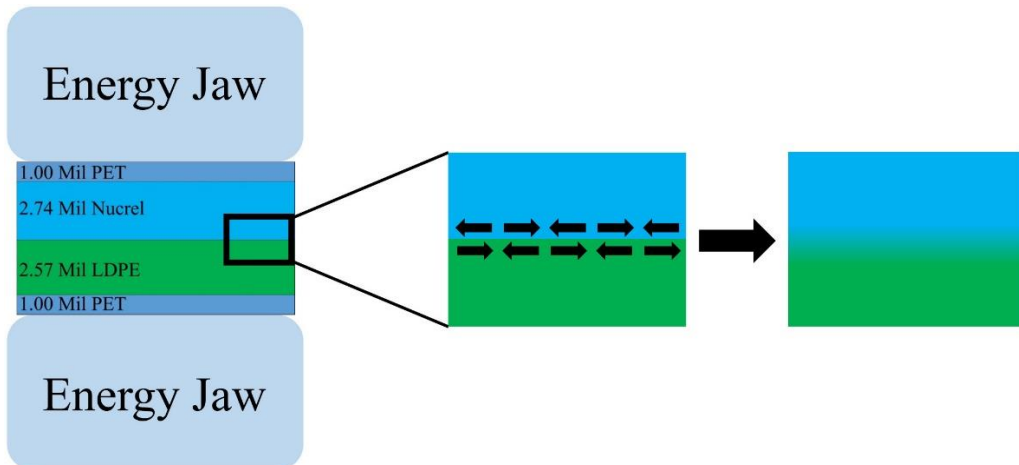

Figure 7: Diagram Representing Internal Heating

Heated tooling sealing is a type of external heating. The tool (often referred to as the seal jaw) is heated. When the heated tool is brought into contact with the polymer film to be

sealed, heat is conducted to the seal interface and a seal is formed. Most thermoplastic materials can be sealed with heated tool sealing. This common method is easy to understand, inexpensive, and cheap to maintain. However, there are also some disadvantages to heated tool sealing. Hot tack can be an issue for some processes, especially vertical form fill and seal (VFFS). On a VFFS machine, the weight of the product rests on a freshly made seal as part of the filling process. Time is needed for the heated tool to come up to the desired temperature and stabilize at that temperature. Time is also needed for the heat energy to be conducted through the polymer structure to the seal interface. Also, the pressure necessary for the seal interface to have intimate contact can cause squeeze out, also called a seal bead.

Squeeze out can occur at the edge of the seal interface when the polymer is molten. The molten polymer moves from an area of high pressure (in the seal jaws) to an area of low pressure (outside of the seal jaws) (Darby, 2015). Squeeze out is unsightly, and can weaken the seal in severe cases. Heated platen sealing is a type of sealing which is similar to heated tooling sealing, except that a distinction is sometimes drawn in that the platen is larger or the platen seals several packages at once (Darby, 2015).

Impulse sealing is a type of external heating with additional options for control of the seal parameters. With this method, the material enters the seal jaws while the jaws are cool, the jaws heat while holding the material under pressure, cool while holding the material under pressure, then release the material. It is possible to control the heating rate, the final temperature, the cooling rate, and the end cooling temperature with impulse sealing. Since cooling is part of the sealing cycle, hot tack is less important because the material is at least partially cooled when it leaves the seal jaws. The system is fairly easy to understand, and it is able to seal a broad range of thermoplastic polymers. However, the system also has a higher

maintenance cost associated with the heating element burning out. The high temperature can also burn through some materials. Because of the short time in which the system sustains a high temperature, accurate temperature measurements can also be challenging to acquire. The seal made with this system is aesthetically pleasing, but because it is often thin, it can have issues with package integrity. With impulse sealing, it is easier to control the current going into the heating element rather than the temperature of the heating element. The correct current setting can vary between systems, making troubleshooting challenging (Darby, 2015).

Hot gas sealing is a type of external heating where the material to be sealed is heated by a flow of hot gas, then pressed together to form a seal. The gas used to heat the material can be inert (nitrogen), non-oxidizing (carbon dioxide), or atmospheric air depending on the requirements of the system (Darby, 2015). This system is appropriate for use where the product being sealed into the package could damage a system with heating jaws. This system is also appropriate where it is impractical to heat the entire structure to make a seal, as the hot gas can be directed at the seal interface. It is impractical to heat the entire structure if the structure is thick, does not conduct heat well, or could be damaged by heated jaws. This method can work for any polymer which is heat sealable. However, due to the heating nature of the system, the flow of hot gas can oxidize the surface of the polymer that will become the seal interface. Oxidized seal interfaces do not seal well. The system also does not heat the seal interface as quickly as a system with direct contact. This is because indirect contact (convection) does not heat as efficiently as direct contact (conduction).

Radiant heating is a type of external heating. Radiant heating is an indirect contact based method where the seal interface is heated before the seal interface has pressure applied. This system allows for high line speeds because the heated element in the system does not have

to move in order to make the seal. This system is useful when it is impossible to use a direct contact heating system. An example of a process which uses radiant heating is the bottom seal on a bundle of paper towels. Due to the nature of the processing with some types of equipment, a radiant heat seal is sometimes not aesthetically pleasing. Also, radiant heating has limited utility because of the high temperatures required to effectively operate. By the nature of the operation, excess heat is applied to the area around the heat seal. This makes the use of oriented films, or films which tend to distort when heated, challenging.

Induction sealing is a type of internal heating. Induction is: “the production of an electric or magnetic state by the proximity (without contact) of an electrified or magnetized body” (Merriam-Webster, Incorporated, 2015). When the alternating magnetic field is rapidly alternated, certain metals in the field will heat. If such a metal is laminated to sealant layer, a seal can form (Selke, Culter, & Hernandez, 2004). Induction sealing is used in the medical industry and food industry for sealing lidding to bottles for tamper evidence. In this process, pressure is applied to the seal interface by the force of the cap screwed onto the bottle. Heating is controlled by the length of the magnetic field along the line, the line speed, and the strength of the magnetic field. This type of system is simple to set up, and the strength of the seal can be controlled by varying the power the magnetic field generator. However, only structures containing metal can be used with this sealing system as the heating of the seal layer is based on the heating of an adjacent metal layer. The presence of metal in the package can make metal detection (an important final process in the food and pharmaceutical industry before the product is distributed to the consumer) challenging. Also, the location of metal in the vicinity of the inductive field generator needs to be considered. Any ferrous or aluminum

metal too close to the inductive field generator will be heated. For this reason, the conveyor beneath the inductive field generator is often non-metallic.

Dielectric sealing is a type of internal heating. This system uses an oscillating high frequency electric field to transmit energy to the seal interface without the use of a metal element in the field (Selke, Culter, & Hernandez, 2004). This system requires the polymer being sealed to be polar. Common polar polymers include: ethylene-vinyl acetate (EVA), nylon, glycol modified polyethylene terephthalate (PETG), polyvinyl chloride (PVC), and polyvinylidene chloride (PVDC). Non-polar polymers which will not seal with a dielectric system include: all types of polyethylene (PE), crystalline polyethylene terephthalate (CPET), polypropylene (PP), and polystyrene (PS), as well as others. This system is common in non-packaging applications where the material to be sealed is susceptible to deformation under the high heat of an external sealing method. This system affords for a good seal appearance since the seal can be cooled under pressure. However, this system has limited application because it can only seal polymers which have a certain set of electric qualities including polarity.

Ultrasonic sealing is a type of sealing which uses ultrasonic frequencies to direct energy to the seal interface. Ultrasonic is defined as: "having a frequency above the human ear's audibility limit of about 20,000 hertz" (Merriam-Webster, Incorporated, 2015). Ultrasonic sealers usually operate in the range from 20,000 hertz (20 kHz) to 40,000 hertz (40 kHz) (Darby, 2015). This method of sealing is common with thick structures, which would take too long to heat to the appropriate temperature. Such structures include thick tubes intended for some cosmetics, and some retort structures. The ultrasonic energy causes the two polymer layers being sealed together at the interface to rub together rapidly and melt. The energy is applied when the structure is under pressure, so a seal is formed. This method is useful when the

material to be sealed is sensitive to excess heat, or the seal interface is contaminated. The process is high speed, does not form debris, and adaptable to many shapes. However, an ultrasonic sealing system is costly and easy to damage. Also, certain materials respond better to certain frequencies. So, a change in material may have to result in a change in the tooling on the ultrasonic sealer.

There are several more technologies also used for heat sealing. These include: spin welding, laser welding, cohesive sealing (also called cold sealing), solvent welding, and ultraviolet (UV) sealing.

In the research to be conducted for this thesis, the point of interest was to determine how far polymer chains move during sealing. When a heat seal is made, it is thought that the polymer chains of the seal diffuse into each other across the seal interface. It was previously found that diffusion in heat seals is traceable. Diffusion can be defined as: "Movement of a fluid from an area of higher concentration to an area of lower concentration" (about.com, 2015). When poly(ethylene-co-acrylic acid) was heat sealed to a zinc neutralized ionomer, energy dispersive x-ray spectrography (EDX) could be used to trace the diffusion of the zinc ion across the heat seal. All tracing was done after the heat seal had been allowed to cool for a minimum of 24 hours (Cooper, 2014).

When measuring ion diffusion via EDX, some predictions can be made related to the accuracy of the measurement. The Anderson-Hasler X-Ray Range is used to predict the depth of penetration of an x-ray into the sample. The spatial resolution of the x-ray analysis can also be predicted. These predictions are discussed in the materials and methods section and applied in the results section.

In previous work, both the slope of the diffusion and the diffusion distance showed a strong correlation to seal strength. A steeper slope relates to a more abrupt transition between bulk materials. Slope can be defined as a measure of steepness of a line, or a section of line, connecting two points (Study.com, 2015). Increasing the seal temperature caused the slopes of diffusion to decrease. A decreased slope was related to an increased diffusion distance. Diffusion was measured by ion concentration in the previous study.

However, it was unknown based on the findings of a previous study if the diffusion of the polymer was traced or if the diffusion of the zinc ion was traced. This is because of a phenomenon known as ion hopping. When ion hopping occurs, the ion travels a different distance than the bulk of the sample (Cooper, 2014). If the trace ion is added to the heat seal after the seal is made, there is not a possibility for ion hopping to occur.

Previous work quantifying ion hopping was done on a time scale longer than that of a heat seal. The shortest time used where ion hopping was quantifiable was 5 hours at 150°C (302°F) (Register & Tierney, 2002). It was also found that no appreciable ion hopping occurred at room temperature over a span of four months. The ions used in the ion hopping study were sodium, magnesium, lithium, and calcium.

Previous research into diffusion at the heat seal is limited. More research has been focused on bonding between dissimilar materials. It is recommended by Grewell that ultrasonic sealing be used to bond dissimilar materials (Benatar & Grewell, 2007). Research has been done where the adhesion strength of dissimilar polymers was measured. Adhesion strength can be defined as the measurement of adhesion, or the attachment between adhesive and substrate (Janalta Interactive Inc., 2015). The research points to the conclusion that a greater number of

chain entanglements across a seal interface lead to a higher bond strength (Cole, Cook, & Macosko, 2003). In the adhesion strength of dissimilar polymer study, the adhesion strength was measured via a crack propagation test. The number of chain entanglements across the seal interface was estimated based on a model.

Research has been conducted where the mixing of HDPE and LLDPE was studied while the materials were kept at molten conditions. The researchers cast a series of microlayers (layers less than 50 $\mu$ m thick) of alternating LLDPE and HDPE. When this structure was heated to 200°C (392°F), diffusion was apparent after 600 minutes when the structure was examined with optical microscopy (Baer, et al., 1998).



## OVERVIEW OF SCANNING ELECTRON MICROSCOPY

Scanning Electron Microscopy, or SEM, is an analytical technique based on principles similar to light microscopy. A light microscope, or LM, is the simplest and most common type of microscope. A SEM is similar to a LM as shown in Figure 8. Both have a source of illumination, lenses, a place upon which to put the specimen, and a detector. In light microscopy, the source of illumination is a light in the visible range. The condenser lens focuses light onto the specimen, the objective lens magnifies the image, and the projection lens further adjusts the image to make it suitable for human observation (Spring & Davidson, 2015). In scanning electron microscopy the source of illumination is an electron source, the lenses are electromagnetic, and the resultant electrons are detected with an electron detector (Australian Centre for Microscopy & Microanalysis, 2014). It is important to note that in SEM the electrons are reflected off of the surface, while in LM the photons are transmitted through the object of interest.

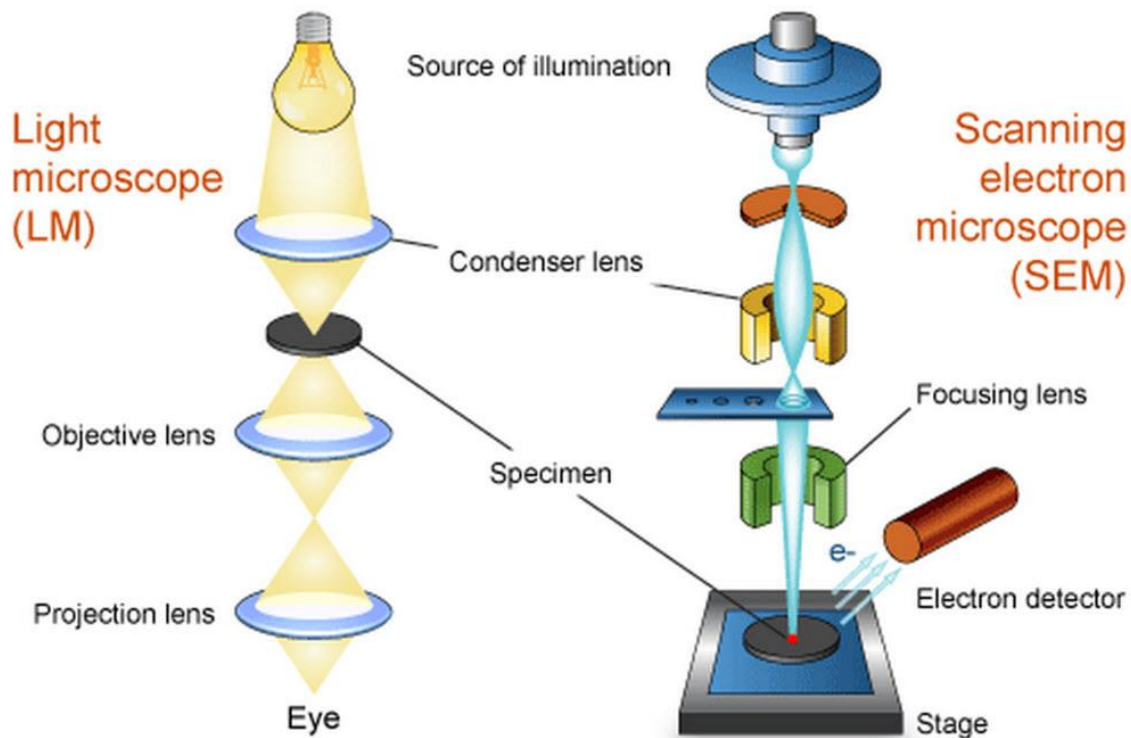

Figure 8: Comparison of LM to SEM, (Australian Centre for Microscopy & Microanalysis, 2014)

The resolution of a light microscope is limited by the relatively long wavelengths of visible light. Resolution can be defined as being able to distinguish two points as separate entities (Australian Centre for Microscopy & Microanalysis, 2014). The best resolution achievable with light microscopy is approximately 200nm. To be able to view images at higher resolution, a system which utilizes some type of detectable particle with shorter wavelengths is needed. In advanced SEM systems, electrons can be produced so that images recorded from a SEM can have resolution as high as 5nm.

Other advantages of SEM include high depth of field, the ability to identify and quantify elements present in a sample, and high magnification. Depth of field can be defined as: “the range of distance in front of and behind an object focused by an optical instrument, such as a

camera or microscope, within which other objects will also appear clear and sharply defined in the resulting image” (Dictionary.com,LLC., 2015). High depth of field means that many parts of a sample are able to be viewed at once as a large depth of the image is in focus.

The ability to identify and quantify elements present in a sample is called energy dispersive x-ray spectrography (EDX). This technique is rooted in the principle that elements give off unique x-ray signatures when they interact with ionizing radiation. Ionizing radiation can be defined as: “radiation with enough energy so that during an interaction with an atom, it can remove tightly bound electrons from the orbit of an atom, causing the atom to become charged or ionized” (WHO, 2015). High magnification means up to approximately 1,000,000x specimen magnification on some SEM systems as opposed to up to 1,500x specimen magnification with LM. High magnification without high resolution can enlarge microscopic features. However, it is desirable to have high resolution as well as high magnification in order to increase the amount of detail visible in a microscopic sample (Science Learning Hub, The University of Waikato, 2015).

There are also drawbacks to using an SEM system when compared to LM. SEM images are produced in grayscale. This is because the wavelengths of the collected electrons do not directly correlate with the wavelengths of visible light. The most common types of SEM images are akin to intensity maps, things which appear lighter in an unedited SEM image “reflect” electrons more efficiently. Another drawback to using an SEM is that the chamber where the electron beam interacts with the sample is in a vacuum. The sample chamber is held at a vacuum because the electron beam must pass through the chamber before it interacts with the sample. If there is atmosphere (nitrogen, oxygen, water vapor, and argon) in the chamber, then

the electron beam will interact with the atmosphere before it interacts with the sample. For this reason, atmosphere in the chamber will cause erroneous results. This means that samples must be free of water, do not off-gas under vacuum, and maintain their structural integrity under vacuum. It is best when materials which are examined under an SEM are conductive. Since a high voltage electron beam is directed at the sample during analysis, the sample will build up charge if it is not grounded. There are steps to examine non-conductive samples such as keeping a minimum atmosphere of approximately 50pa (0.000493 atm) in the sample chamber, but resolution is sacrificed.

In a SEM, there is a variety of ways to collect information once the electrons interact with the surface of the specimen. To view topographical information of a sample, a detector called a secondary electron detector is used. Secondary electrons are low energy electrons emitted from near the surface of a sample, they are ideal to view topographical information on the sample (Australian Centre for Microscopy & Microanalysis, 2014). To view general information on the sample, a backscattered electron detector is used. Backscattered electrons “result from elastic interactions between the incident electrons and the target specimen” (Bordeaux, 2011). Backscattered electrons detectors are useful for viewing contrast based on elemental composition, as heavier elements appear brighter in the image. Heavier elements are more efficient at back scattering electrons. For quantitative elemental analysis an energy dispersive x-ray spectrography detector, or EDX detector, is used. X-rays are generated from deeper within the sample than backscattered electrons or secondary electrons as shown in Figure 9. For this reason, they are valuable for quantifying the elements in the sample. In Figure

9, the area of the sample being evaluated has been shaded light gray. The sample being evaluated is below the heaviest black horizontal line near the top of the figure.

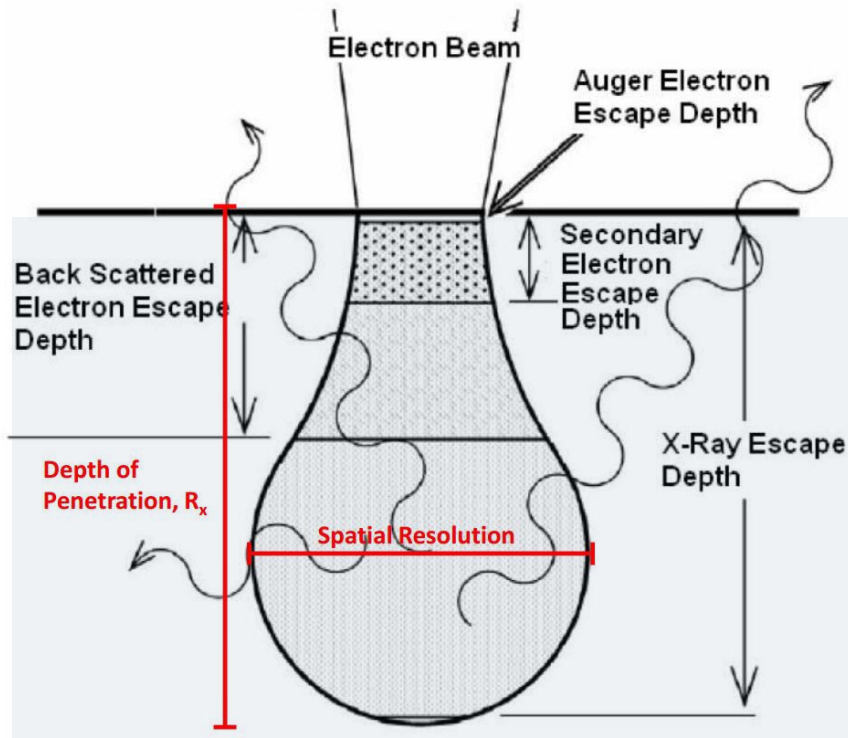

Figure 9: Origin of Detectable Electrons and X-rays after Interaction with Electron Beam (Hafner, 2015)

When examining sodium concentrations on a sample with low voltage, the x-ray emission of interest is a characteristic x-ray called a  $k\beta_1$  emission. The naming system will be discussed later in this section.

For x-ray microanalysis, it is necessary to generate x-rays from the sample. All elements have a critical ionization energy ( $E_c$ ). An understanding of the critical ionization energy is necessary to the understanding of x-ray microanalysis. Two definitions of  $E_c$  follow.

Critical Ionization Energy Definitions:

“Because the energy of each shell and subshell is sharply defined, the minimum energy necessary to remove an electron from a specific shell has a sharply defined value as well. This energy is called the critical ionization or excitation energy  $E_c$ , also known as the excitation potential or x-ray absorption edge energy for example,  $E_K$  and  $E_L$ . Each shell and subshell of an atom requires a different critical ionization energy for electron removal..... The critical ionization energy is an important parameter in calculating characteristic x-ray intensities. As discussed in following chapters, for x-ray microanalysis we typically operate the SEM at energies two to three times the critical ionization energies of the elements of interest.”(Goldstein, et al., 2003)

“Critical Ionization Energy: The electron beam has to transfer an amount of energy greater than a critical value to the inner shell electron to ionize the atom. This energy is called the critical ionization energy ( $E_c$ ); if we’re going to generate X-rays, then the beam energy  $E_0$  must be greater than  $E_c$ . The value of  $E_c$  increases as electrons are more tightly bound to the nucleus, so the innermost shell (K) has a higher  $E_c$  than the L shell, and so on.” (Williams & Carter, 1996) The  $E_c$  of each ionized atom is unique and can be quantified. (Williams & Carter, 1996)

Characteristic x-ray measurements can be taken individually, or several can be taken in close proximity. If several hundred are taken in close proximity, meaningful data can be collected. This is called a line scan. A line scan is an analysis technique on a SEM which moves the electron beam probe along a pre-defined line on the sample (Centre for Imaging and Analysis, 2015). The x-ray count rate is correlated to the probe position. If the scan is taken across an interface, meaningful concentration data can be collected. It is important to note that the spatial resolution of such points can be calculated.

If a line scan is 50 $\mu\text{m}$  in length, there are 500 data points collected if each point is 100nm apart. With a 1.02 $\mu\text{m}$  spatial resolution, each point can be envisioned as a circle with a radius of 0.51 $\mu\text{m}$ . Each circle overlaps 87.6% with the neighboring circle. The center of each circle is the data collection point. The centers are 0.1 $\mu\text{m}$  apart. Two circles next to each other with the same diameter, and offset a known distance can be referred to as a symmetric lens. The area of the symmetric lens can be calculated with trigonometry as shown in Equation 1. A visualization of the area calculated is shown in yellow in Figure 10. Figure 11 shows the overlap of the data points drawn to scale. The overlap of the points is shown in purple.

*Equation 1: Area of a Symmetric Lens*

$$\text{Area Symmetric Lens} = -\frac{1}{2}d\sqrt{4a^2 - d^2} - 2a^2 \tan^{-1}\left(\frac{d}{\sqrt{4a^2 - d^2}}\right) + \pi a^2$$

a= the radius of the circle, 0.51 $\mu\text{m}$

d= the offset of the circles, 0.1 $\mu\text{m}$

The area of the circle is 0.817 $\mu\text{m}^2$ , the area of the symmetric lens is 0.715 $\mu\text{m}^2$ . There is a 87.6% overlap between sampling areas with a 0.1 $\mu\text{m}$  spacing between data points with a 3.00 keV electron beam examining sodium with a critical ionization energy of 1.07 keV. This calculation is important because it illustrates how smoothing occurs in the original data. EDX is a “noisy” technique which generated data that can be partially smoothed during collection. Because EDX is a “noisy” technique, it also is important to use a data analysis method which is able to manage the “noise”. A SAS<sup>®</sup> program was written as a raw data analysis technique. The use of the SAS<sup>®</sup> program will be discussed later. The program was written to work with averages, so it managed the inherently “noisy” data well.

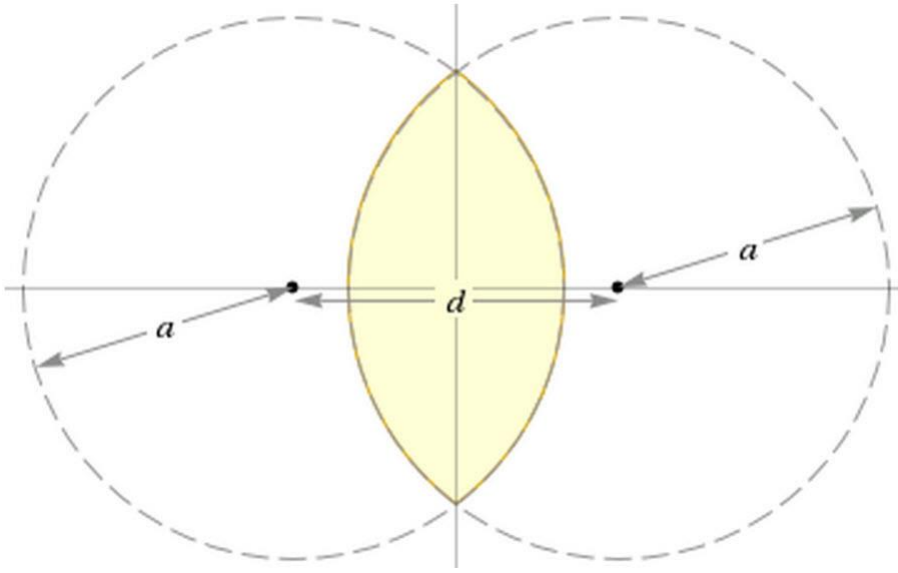

Figure 10: Visualization of a Symmetric Lens, (Wolfram Alpha LLC, 2015)

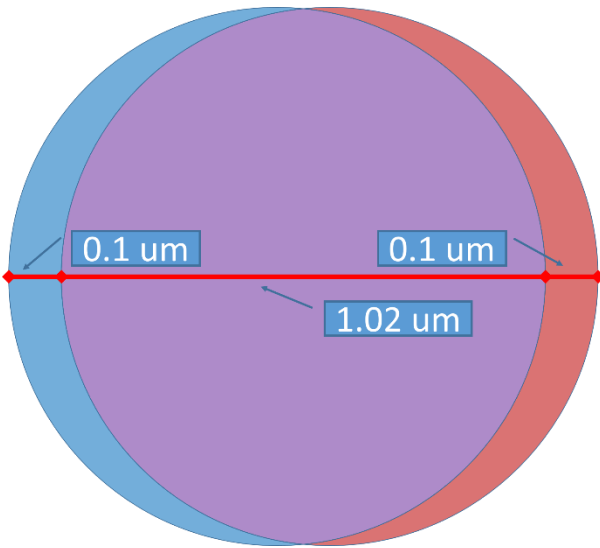

Figure 11: Spatial Resolution Visualization to Scale

It is known whether or not the point of interest on the spectra is from sodium because of how the electrons move within the electron shell configuration when they are struck with ionizing radiation. When sodium is exposed to ionizing radiation with enough energy, it emits an x-ray with 1,071.1 eV of energy (Bearden, 1967). The x-ray signal for sodium which is being



detected is called the  $k\beta_1$  line. The “k” denotes the K shell, where the initial ionization took place. An electron from the  $M_{III}$  subshell then fills the vacancy in the K shell. This electron drop releases energy which corresponds to the  $k\beta_1$  characteristic X-Ray emission. Figure 12 has been highlighted to show the transition important to the  $k\beta_1$  characteristic X-ray emission.

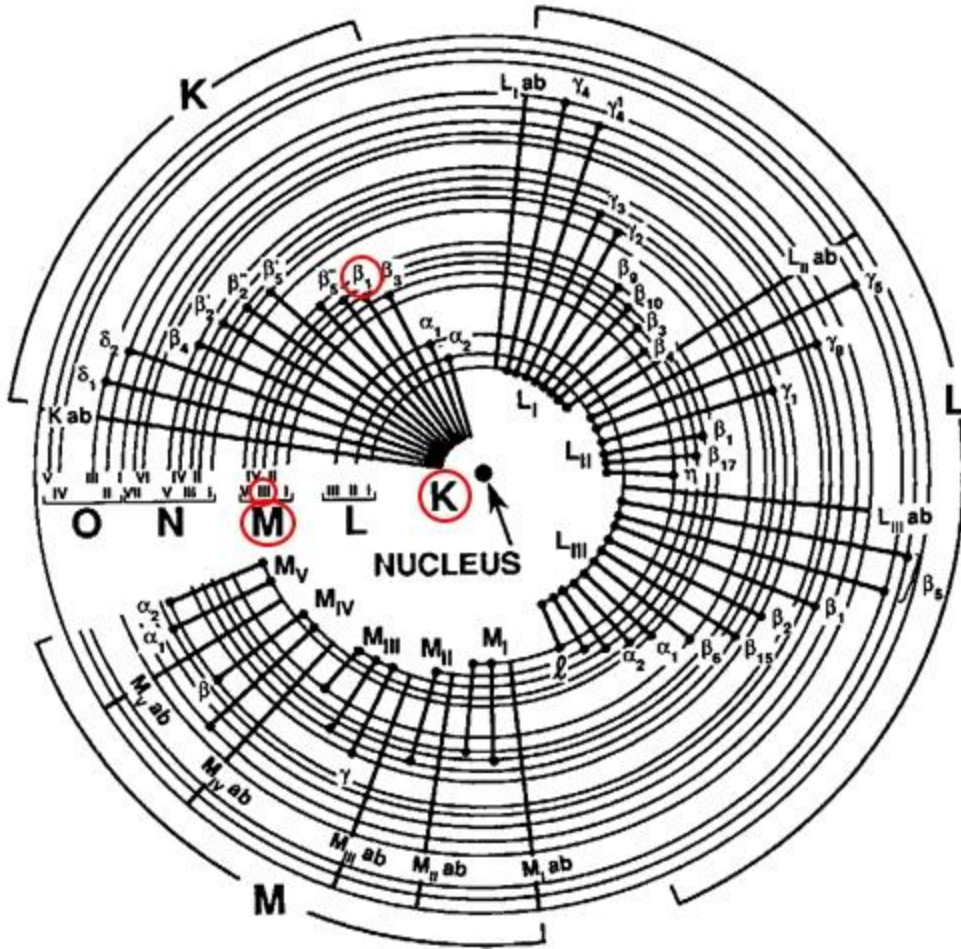

Figure 12: Electron Shell Ionization Nomenclature, (Woldseth, 1973)

The electron beam voltage is chosen because of many factors. If a sample is non-conductive, a lower electron beam voltage is chosen to reduce charging of the sample. Charging is when the sample builds up undesirable charge, and the reading of the sample becomes unusable. The buildup of charge renders the samples unusable because of the negative charge

of electrons. Both the electrons building up on the surface of the sample and the electrons from the electron beam have a negative charge. Because like charges repel, the negatively charged surface acts as a mirror to the negatively charged electron beam. In x-ray microanalysis, when a higher electron beam voltage is used, the electron beam penetrates farther into the sample. If the sample is homogeneous, this is acceptable. However, a non-homogeneous sample can pose a problem. In x-ray microanalysis, a higher voltage corresponds to a larger x-ray interaction volume. This larger interaction volume decreases spatial resolution, which is highlighted in Figure 9.

The optimum x-ray collection conditions exist at approximately 2 times to 3 times the voltage of the desired characteristic x-ray emission, a term called overvoltage (Goldstein, et al., 2003). Exciting the sodium in the sample with exactly 1071.1 eV would not produce a desirable result. Sodium was chosen specifically as the target element because of its low  $E_c$ . This means that sodium can be detected with a low electron beam energy.

## MATERIALS AND METHODS

### Dow 501i LDPE

Dow 501i LDPE (The Dow Chemical Company, Midland, Michigan) was chosen for its chemical inertness and for its ready availability. The polymer was cast using a Killion (Killion, Cedar Grove, New Jersey) lab scale extruder, which is shown in Figure 13. The film was chilled, transported, and rewound with the assembly shown in Figure 14. The extruder had a 2.54 cm (1" screw), a 20.3 cm (8") wide coat hanger die, and the die gap was set to 0.76 mm (0.030"). Table 1 shows the extruder settings for casting the 501i LDPE used in the experiments. The thermocouple for the melt was not functioning.

*Table 1: 501i LDPE Extrusion Settings*

501i LDPE Extrusion Settings	
Zone 1 Temperature	121C (250 F)
Zone 2 Temperature	182 C (360 F)
Zone 3 Temperature	196 C (385 F)
Adaptor Temperature	196 C (385 F)
Die Temperature	196 C (385 F)
Melt Temperature	188 C (371 F)
Screw RPMs	39.5 RPM
Back Pressure	3034 kPa (440 psi)
Air Gap	3.5 cm (1.375")
Rewind Speed	4.6 mpm (15 fpm)
Chill Roll Temperature	38 C (100 F)
Rewinder Tension Setting	60/100



Figure 13: The Killion Cast Film Extruder

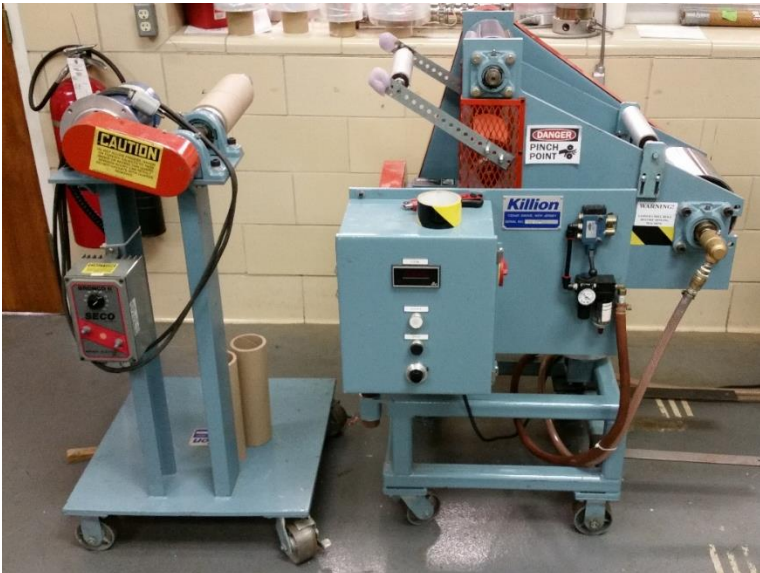

Figure 14: The Chill Roll, Nip Roll, and Rewinder

The desired sample of film was cut in the machine direction 5.1 cm (2 inches) from the edge of the film. The sample was cut to be 3.8 cm (1.5 inches) in the cross/transverse direction, and 5.1 cm (2 inches) in the machine direction. The section was chosen to get consistent thickness and to avoid the edge bead. A specification sheet for Dow 501i LDPE has been included in the appendix.

### **Nucrel®1202HC**

Nucrel®1202HC (DuPont, Wilmington, Delaware) was chosen for its reactivity. The polymer is 11.5% by weight methacrylic acid monomers. This means that 88.5% of the weight of the polymer is LDPE monomers. The HC stands for high clarity. When this polymer is submerged in a bath of sodium hydroxide (NaOH), the methacrylic acid groups react to form a polymer which is neutralized on the surface. The neutralized acid groups at the surface became a salt, specifically a sodium neutralized ionomer. This reactivity is of paramount importance to the study. Nucrel®1202HC processes in conventional extrusion equipment. Table 2 shows the extrusion settings used for the Nucrel®1202HC used in the experiments. The thermocouple for the melt temperature was loose, so that particular measurement was unreliable. \*The chill roll temperature is a missing data point from this set. It is reasonable to assume the chill roll was approximately 38°C (100°F) since the rewind conditions were similar to the LDPE run in table 1.

*Table 2: Nucrel®1202HC Extrusion Settings*

Nucrel®1202HC Extrusion Settings	
Zone 1 Temperature	121 C (250 F)
Zone 2 Temperature	196 C (385 F)
Zone 3 Temperature	216 C (420 F)
Adaptor Temperature	216 C (420 F)
Die Temperature	196 C (385 F)
Melt Temperature	202 C (396 F)

Screw RPMs	35.0 RPM
Back Pressure	1379 kPa (200 psi)
Air Gap	3.2 cm (1.25")
Rewind Speed	15 fpm
Chill Roll Temperature	38 C (100 F*)
Rewinder Tension Setting	70/100

The desired section of the film was cut 6.4 cm (2.5") from the edge of the film. The sample size was cut to 3.8 cm (1.5") in the machine direction, and 5.1 cm (2") in the cross direction. This section was chosen to get consistent thickness and to avoid the edge bead. A spec sheet has been included for Nucrel®1202 HC in the appendix.

Acid copolymers, such as Nucrel® 1202HC, require special consideration when running in a conventional extruder. The extruder was brought up to temperature with Dow 501i LDPE. Once the machine was warm, and gels were no longer an issue, the hopper was temporarily removed from the extruder. After the screw became visible, a 50% Nucrel®1202HC and 50% Dow 501i LDPE mix was introduced into the hopper and extruder. After a five minute wait to ensure the 50%-50% mixture had passed through the extruder, the hopper on the extruder was once again closed. Once the screw was visible, 100% Nucrel®1202HC was introduced into the extruder. Another five minutes passed before the material was considered to be 100% Nucrel®1202HC. Once enough film was made from the Nucrel®1202HC, the hopper was closed. Dow 501i LDPE was then introduced to the extruder to begin the purge cycle.

It is important to purge the extruder of any acid copolymer before the extruder is shut down. If the extruder is shut down with acid copolymer in the system, the internal components can be attacked by the acid component of the polymer. To prevent damaging the internal components of the extruder, a "Disco" style purge was run. A Disco style purge involves varying

the screw speed widely. The screw speed is held at each set point for approximately one minute, and then changed. The exact particularities of screw speed are not important. Varying the screw speed widely is the important aspect of a “Disco” style purge (Stoner, 2015).

### **Sealing Samples**

Samples were sealed on a Sentinel lab scale heat sealer (Sentinel Packaging Industries, Hayannis, Massachusetts). An image of the heat sealer is shown in Figure 15. The guard on the sealer was temporarily held up with tape to facilitate photography. Both the top and the bottom jaw were heated. Both the top and the bottom jaw were coated with PTFE to prevent sticking to the jaw. The samples were made with a 1.0s dwell time, a 0.95 cm (3/8”) seal bar, and 276kPa (40 psi) sealing pressure. 276kPa (40 psi) at the sealing jaw corresponded to 139.3 line kPa (20.2 line psi) coming into the machine.

The 1.0 second dwell time was determined to be appropriate because of previous research done to determine the time needed for a seal interface to reach the same temperature as the seal jaws. A portion of the research was done with films 50.8 microns (2.0 mil thick), sealed in a PET sleeve to prevent sticking. There was no PTFE/fiberglass cloth cover on the seal jaws. The research states: “...the interfacial temperature achieves a value within 5°C (9°F) of the set platen temperature in approximately 0.5 s and that about 1 s is required to approach the set platen temperature to within 1-2°C (1.8°F-3.6°F).” (Meka & Stehling, 1994).

The 276 kPa (40 psi) jaw pressure was determined to be sufficient because of previous research done. The research states: “The minimum pressure required under ideal sealing conditions... is probably substantially smaller than the smallest pressure used in our experiments: 15N/cm<sup>2</sup>. Under practical operating conditions, pressures of about 5N/cm<sup>2</sup> or

more are probably desirable to bring the opposing film surfaces into contact.” (Meka & Stehling, 1994).  $15\text{N/cm}^2$  corresponds to 150 kPa (21.8 psi).  $5\text{N/cm}^2$  corresponds to 50 kPa (7.3 psi).

The temperature control system on the heat sealer exhibits offset from the set point, so a supplemental thermocouple system was used to verify temperatures. The supplemental thermocouple system was a Digi-Sense Dual J,T,E,K thermocouple thermometer (Eutech Instruments, Ayer Rajah Crescent, Singapore). An image of the supplemental thermocouple system is shown in Figure 16. Over the range of the seal temperatures tested, the supplemental thermocouple ranges in accuracy from  $\pm 0.5^\circ\text{C}$  ( $\pm 0.9^\circ\text{F}$ ) to  $\pm 0.56^\circ\text{C}$  ( $\pm 1.0^\circ\text{F}$ ) (Cole-Parmer, 2015). The top number corresponds to the top jaw, the bottom number corresponds to the bottom jaw. The leads for the thermocouple thermometer were inserted into the seal jaws as shown in Figure 17. The small holes are present in the sealing jaws on the Sentinel heat sealer because of their manufacturing process.



Figure 15: Sentinel Lab Scale Heat Sealer





Figure 16: The Digi-Sense JTEK Thermocouple

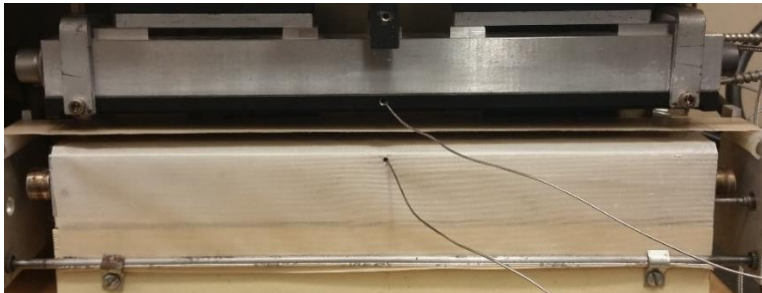

Figure 17: The Thermocouple Leads from the Top and Bottom Seal Jaws

When creating seals for testing the sealer jaws were cycled several times to bring the jaws to a stable reading. After the jaws had reached a stable reading, sealing could begin. The jaws were kept within 1.1°C (2°F) of each other while sealing. As long as the average of the two jaws was within 0.56°C (1°F) of the desired set point, this was considered acceptable. The

temperature control unit in the heat sealer is capable of holding the temperature to  $\pm 1.1^{\circ}\text{C}$  ( $\pm 2^{\circ}\text{F}$ ).

The seals were made in the same location on the heat sealer jaws to mitigate any temperature or pressure profile present across the width of the seal jaw. The thermocouple leads in Figure 15 Figure 17 were used as a reference point to ensure that each seal was made in the same spot on the seal jaws. This location also helped to ensure the reading on the supplemental thermocouple unit corresponded to the utilized portion of the seal jaws.

All seals were made inside of a 92ga PET sleeve. This technique was used to eliminate the possibility of sticking the test materials to the seal jaws. Nucrel®1202HC is a tacky polymer which has a tendency to stick to the PTFE coating on the seal jaws. The seals were exposed to the radiant heat of the seal jaws for as little time as possible to ensure consistency between samples.

Twenty two seals were made for each temperature. Twelve of the seals were intended for seal strength testing. Ten of the seals were intended for diffusion measurement. The time between the creation of the seal and the testing of the seal strength was approximately 30 minutes. In preliminary testing, longer wait times between creating the seal and testing the seal strength resulted in inconsistencies. Figure 18 shows the structure which went into the heat sealer. The image has been drawn to scale. The PET was not a part of the seal strength testing, it was present to prevent the Nucrel® or the LDPE from adhering to the seal jaws.

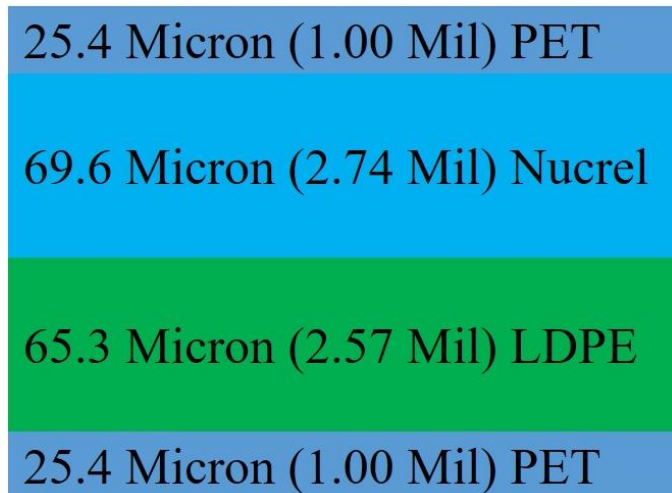

*Figure 18: Sealed Structure to Scale*

#### **Sample Prep for Instron T10000 with 500lb Load Cell**

Before the strength of the seals were tested, the seals were manually laminated to precut rectangles of 3M 3381 Metal Repair Tape (3M, Minneapolis, MN). Manual lamination refers to carefully adhering the precut rectangles of pressure sensitive tape to the seal samples. After the tape was adhered to the samples, it was pressed down to ensure the tape was in full contact with the sample. Automatic roll to roll lamination was not an option due to material quantity restraints.

The tape was laminated to both sides of the seals to prevent extensibility in the polymer films from affecting the seal strength test results. The tape was cut to be 3.2 cm (1.25 inches) in the machine direction and 5.1 cm (2.0 inches) in the cross direction. The tape was shown to have minimal extensibility and high tensile strength when compared to the seal structure. The tape was cut to match the CD of the tape to the MD of the seal samples. This was acceptable due to the tensile properties of the tape. When 2.54 cm (1.00 inches) wide samples were tested, the CD of the tape experienced a brittle failure at 1.02 mm (0.04 inches) of extension

with 6854 grams force average. The MD of the tape experienced a brittle failure at 1.27 mm (0.05 inches) of extension with 6955 grams force average.

Figure 19 shows a seal between LDPE and Nucrel®1202HC before it was adhered to the tape. For scale, the grid in the background is approximately 5.1 cm (2") square. Figure 20 shows a seal after the metal tape has been applied to one side. The orange dot denotes the location of the seal as well as denoting the side of the seal; which is LDPE. Figure 21 shows the opposite side of the seal as Figure 20. There is no dot on the tape for the Nucrel®1202HC side of the seal. Figure 22 shows the taped seal before it was sized to 2.54 cm (1.00 inch) for with a JDC precision sample cutter (Thwing-Albert Instrument Company, Philadelphia, Pennsylvania) for testing on the Satec Instron. The cutter is specifically designed to cut samples to be 2.54 cm (1.00 inch) wide. Figure 23 shows the sample after it was cut. Between each trial temperature, the cutting surfaces of the 2.54 cm (1.00 inches) wide cutter were cleaned with ethyl acetate. An unacceptable amount of adhesive from the metallized tape accumulated on the cutting surfaces after a full set of samples was cut. Between each sample set, the cutter was cleaned thoroughly with ethyl acetate to remove any accumulated adhesive. The sample in Figure 23 lines up with the edge of the cutting platform, indicating that it is a 2.54 cm (1.00 inch) wide cut. After the samples were cut to 2.54 cm (1.00 inches) wide, they were fully prepared to be mounted into the Satec Instron.



*Figure 19: Seal Sample before Modification*



*Figure 20: Seal Sample with One Side Taped*



*Figure 21: Seal Sample with Two Sides Taped*

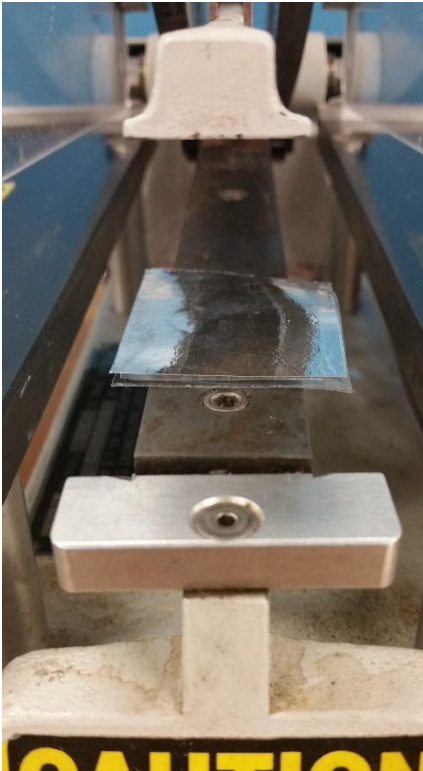

*Figure 22: Taped Seal Sample in Cutter before Cutting*

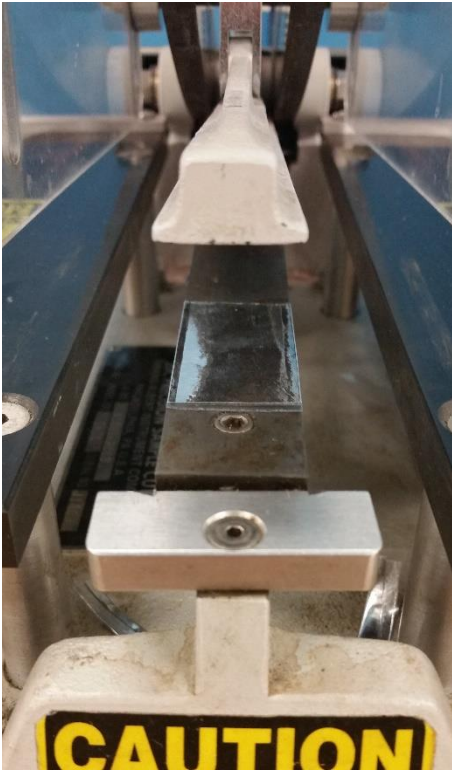

*Figure 23: Taped Seal Sample in Cutter after Sizing to 2.54cm (1.00")*

### **Satec Instron Testing**

The prepared samples were placed into the jaws of the Satec Instron T10000 (Instron, Norwood, Massachusetts) with minimal slack. The load cell is a 500lb Omega Dyne LCHD-500 load cell (Omega Dyne, INC., Sunbury, Ohio.) The seal of each sample was placed perpendicular to the direction of pull to maintain consistency between samples. Samples were loaded into the middle of the jaws in relation to the forward and back position. The gap between the seal jaws was set to 1.27 cm (0.5 inches) to minimize any effect of extensibility of the materials. The seal tail of the sample was placed in between the two jaws, (0.64 cm) 0.25 inches from each jaw. Before each sample was tested, the load cell was zeroed. The seals were pulled at a rate of 10.00 inches/minute.

Sample slip was not encountered with this system for several reasons. Tacky silicon rubber was used in the jaws of the T10000. The structure tested was relatively thick, and the peel strength is relatively weak.

The software used to control the Satec Instron was Instron Bluehill 2 (Instron, Norwood, MA). Figure 24 shows the entire frame of the Satec Instron with the pneumatic jaws in place. Figure 25 shows a side view of a sample in the jaws ready to be pulled. The tail of the sample remained perpendicular to the direction of tension until the seal was pulled because of the dead fold property of aluminum foil.

Figure 26 shows a seal in the process of being pulled. It is important to note that the seal is separating slightly from the tape, and the material is exhibiting some extensibility during the seal pulling process. At elevated sealing temperatures, associated with a stronger seal, the materials pulled away from the tape. The LDPE 501i exhibited more tendency to pull away from the tape than did the Nucrel®1202HC at all temperatures. All results were interpreted using the Bluehill 2 software to yield a numerical result. After a numerical result was achieved, analysis was moved to Microsoft Excel 2013. Mode of failure, any points of fusion, and if the tape was pulled from the sample during testing were recorded for further analysis.





*Figure 24: The Satec Instron when set to a 0.5" Jaw Opening*

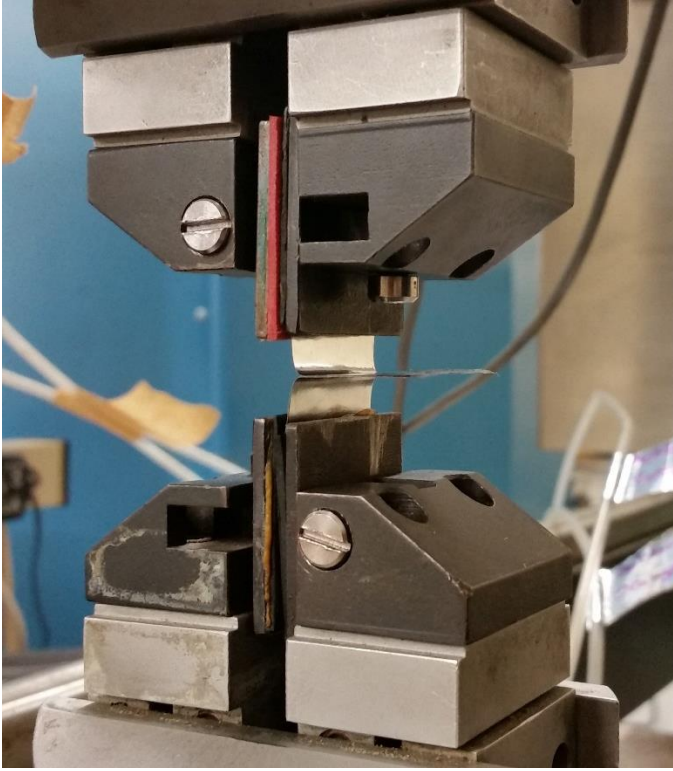

*Figure 25: A Seal Sample Ready to be Pulled in the Satec Instron Jaws*



*Figure 26: A Seal Sample While it is Being Pulled*

### **Differential Scanning Calorimetry (DSC) Analysis**

DSC analysis was performed on both final polymer types used in the study. The DSC used was a 2920 MDSC (TA Instruments, New Castle, DE). This DSC functions best with a sample size between 5.0 mg and 10.0 mg. Polymer samples were cut to size and weight specification for use in a non-hermetic aluminum pans using a clean razor. The weight of the polymer samples was collected with an Ohaus Explorer E00640 scale (Ohaus Corporation, Parsippany, N.J.). After the sample was placed into the DSC, a temperature control program was made in Thermal Advantage Version 1.1A (TA Instruments, New Castle, DE). The temperature control program heated and cooled the sample at 10°C/min. The temperature began at 0°C, heated to 195°C, cooled to 0°C, heated to 195°C, and then ended. The second heating of the sample was to examine the properties of the polymer after the thermal processing history had been erased.

After testing was complete, the data were analyzed with Universal Analysis 2000, Version 4.2E (TA Instruments, New Castle, DE).

### **Sample Prep for Scanning Electron Microscope (SEM)**

A cross section of the seal was created to facilitate analysis using the scanning electron microscope. Cross sections for electron microscopy are usually made with a microtome blade at room temperature conditions. However, when considering the properties of the polymers in the study, room temperature cross section preparation could cause smearing of the seal interface. To avoid smearing the polymer samples, a technique called cryo-sectioning was used. This technique brings both polymers below their glass transition temperatures ( $T_g$ ) before cutting. When a polymer is below its glass transition temperature, it behaves in a brittle manner.

The technique of cryo-sectioning involves cutting the samples in a liquid nitrogen bath. The temperature of liquid nitrogen is  $-196^{\circ}\text{C}$  ( $-321^{\circ}\text{F}$ ) (Cryogenics at NASA, 2015). This is below the  $T_g$  of LDPE, which is  $-125^{\circ}\text{C}$  ( $-193^{\circ}\text{F}$ ) (dos Santos, de Sousa, & Gregorio Jr., 2013). Several other aspects of cryo-sectioning needed to be considered as well. Microtome blades come coated in a light oil, this was removed to prevent contamination of the sample. The microtome blade also needed to be held in a locking jaw needle nose plier during cutting, as the brittle polymer samples offered significant resistance at liquid nitrogen temperatures. After the samples were cross sectioned, the samples were placed on low lint Kimwipes (Kimberly-Clark Worldwide, Inc., Dallas, Texas) to dry. The samples were wet because the temperature change from liquid nitrogen temperature to room temperature caused condensation which needed to be removed. Touching the seal interface was avoided after cutting to prevent contamination.

Figure 27 shows an example of two seals after cryo-sectioning. The sample on the left was cut cleanly, and is appropriate for further analysis. The sample on the right was sectioned roughly, and is not appropriate for further analysis. Note the location of the seal interface at the tips of the arrow, the darker region in both samples near the bottom of the image.

It is important to note that the samples used for SEM analysis were separate from the samples used for seal strength analysis. For each seal temperature, approximately 20 seals were made. Twelve to thirteen of these seals were destroyed during seal testing. Six of the remaining samples were cryo sectioned. This is an un-paired sample preparation technique.

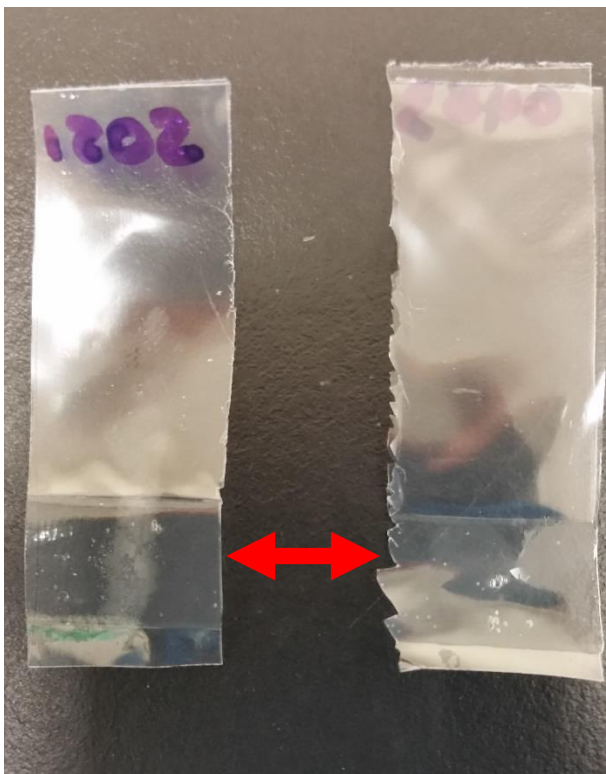

*Figure 27: Example of a Good Shatter (Left) and a Bad Shatter (Right)*

#### **Tagging the Nucrel®1202HC with Sodium Ions**

Nucrel® is a reactive polymer due to the methacrylic acid copolymer content. This copolymer content can be utilized to attach reactants to the surface of the polymer. One

technique which has been established is placing sodium ions on the surface of an acid copolymer using sodium hydroxide (NaOH) (Cooper, 2014). Sodium Hydroxide is a base which reacts with the acid copolymer content on the surface of the Nucrel. The acid copolymer content in the Nucrel® is randomly distributed, there is no bias as to where it is within the film. Because only the seal area is of interest, only the seal area was reacted with NaOH. This reaction effectively “tags” the reactive portions of the seal with sodium ions. Figure 28 shows the chemical structure of the poly (ethylene-co-methacrylic acid), such as Nucrel®1202HC. The bracketed “X” shows the ethylene portion of the polymer, which is 88.5% the weight of the polymer. The bracketed “Y” shows the methacrylic acid portion of the polymer, which is 11.5% the weight of the polymer. The “H” with the red box in Figure 28 is a reactive (acidic) hydrogen, which is replaced by a sodium ion as shown in Figure 29. The reactive hydrogen was replaced with a sodium ion by soaking the polymer in a 2.50M NaOH bath for 24 hours.

The NaOH solution was made by putting 100.0g of dry NaOH pellets into a 1.000 L ± 0.30 mL volumetric flask. This flask was then filled to the line on the neck with deionized water. Dissolving NaOH into water is an exothermic reaction, which caused the solution to become hot to the touch. Since hot water is less dense than room temperature water, the solution was left to cool for 12 hours at room temperature in the covered volumetric flask. Once the solution was at room temperature, the water level in the volumetric flask had dropped by 10-15 mL due to cooling. Once the balance of water was added, the solution was ready for use.

The cryo-sectioned samples were arranged around the perimeter of a petri dish using paper clips to keep them in place, as shown in Figure 30. The samples were soaked in 20mL of

2.5M NaOH, just enough to cover the seal area. During the 24 hour waiting period, the petri dish was covered with its lid and a secondary cover to minimize evaporative losses.

After the 24 hour waiting period, the seals were removed from the soaking solution and washed. The samples were initially dipped into a 400mL bath of deionized water. Then the samples were washed with a stream of water from a pipette filled from a secondary reservoir of deionized water. This was done to eliminate washing the samples with water which had been contaminated by sodium ions. After the washing, the samples were placed on Kimwipes to remove excess moisture. The reaction of the sodium hydroxide with the methacrylic acid sites in the Nucrel® fixed oxygen and sodium onto the surface of seal interface.

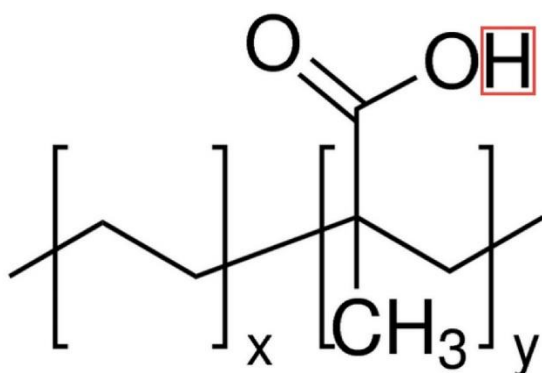

Figure 28: Poly (ethylene-co-methacrylic acid)  
<http://www.sigmaaldrich.com/catalog/product/aldrich/426628?lang=en&region=US>

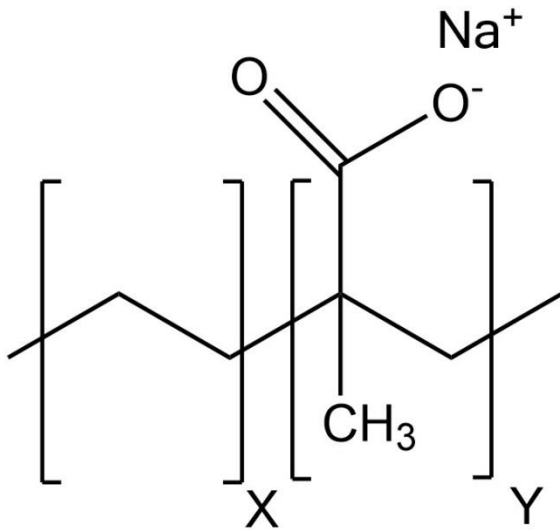

Figure 29: Chemical Structure of Poly (ethylene-co-methacrylic acid) after reaction with NaOH



Figure 30: Seal Samples in a Petri Dish Soaking in NaOH

### Mounting Samples on Conductive Hardware for SEM

The scanning electron microscope operates by emitting a beam of electrons at a surface. If this surface is not grounded, electrons will build up and the data will become unusable.



Polymer samples are not inherently conductive, and will build up electrons if preventative steps are not taken.

The first step of mounting a sample for the SEM was proper sample support. The SEM has high magnification, and any sample movement would cause the image to be blurry. For this sample, proper sample support entailed keeping the polymer between “half-moon” metal discs as shown in Figure 31. The polymer was adhered to the metal discs with conductive tape. The metal discs were made of aluminum, which is conductive. The half-moon discs, with the polymer pressed between them were then adhered, with conductive tape, to a full disc. The full disc is visible, but partially obscured by the half-moon discs, in Figure 19. The secondary mounting is necessary to bring the assembly to an appropriate total height for examination under the SEM. Before any mounting hardware was used, it was cleaned with an ethanol soaked low lint Kimwipe to remove any contaminants. Nitrile gloves were worn to eliminate the possibility of contaminating the sample. Care was taken to label each side of the half-moon disc assembly to ensure each sample was examined in the same scanning direction.



*Figure 31: Polymer Sample Mounted Between Half Moon Discs for SEM*

Samples were mounted to assure that the data recorded were correlated to seal conditions. Figure 32 shows six samples mounted on the multi holder. The multi holder was used to expedite analysis.

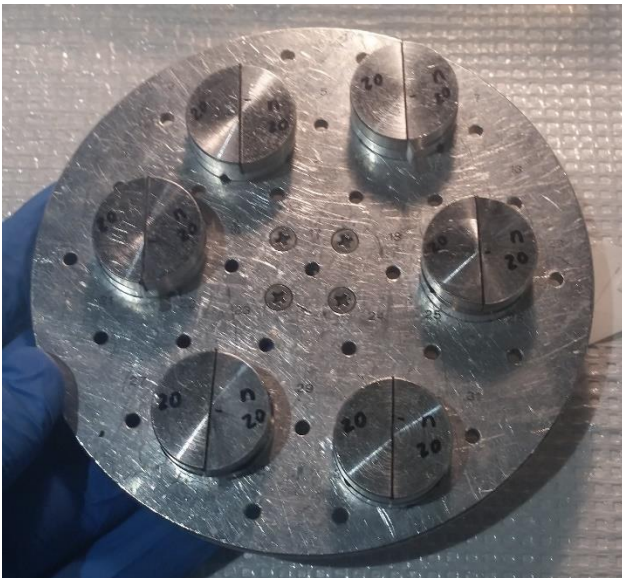

*Figure 32: Samples Mounted on Multi-Holder*

## The Scanning Electron Microscope

The scanning electron microscope used was a Hitachi S-3400N (Hitachi, Ltd., Tokyo, Japan) with an Oxford X-Max 80 x-ray detector (Oxford Instruments plc., Abingdon, United Kingdom). Figure 33 shows a view of the SEM and connected machinery. The main body of the SEM is on the left of the image. The x-ray analyzer is protruding at a 45° angle from the left side of the main body of the SEM. The monitor on the left is used to control the SEM for general use, including backscattered electron imaging. The monitor on the right is used to control the SEM for elemental analysis.



*Figure 33: The Group of Machinery Utilizing the SEM and X-ray Detector*

Table 3 and Table 4 show the settings for the line scan data collection settings and the SEM data collection settings. Settings such as probe current, back scattered electron gain, filament, gun bias, brightness, contrast, aperture alignment, and beam shift change on a daily basis and must be correctly set before meaningful SEM data can be collected.

Table 3: Line Scan Data Collection Settings

Line Scan Settings	
Energy Range	10 keV
Number Of Channels	Auto
Process Time	6
Pixel Dwell Time	10 ms
Line Definition	Points
Number of Points	500
Point Separation	100 nm
Working Distance	10.0 mm
Line Length	50.0 $\mu\text{m}$
Total Live Time	900.0 s
Total Passes	180
Dead Time	18% $\leq$ x
Software	AZtec

Table 4: SEM Data Collection Settings

SEM Settings	
Magnification	800x
Vacuum	50 pa
Electron Beam Voltage	3.00 keV

After line scans results were recorded, the data were analyzed with a program written in statistical analysis software (SAS ©). The code of the program has been included in the appendix. The program is compatible with the free-ware version of SAS ©. The data resulting from the statistical analysis were compiled into Excel 2013 for further analysis.

#### **Analysis of Line Scan Data with SAS © Program**

The SAS© program was written to output several types of data. The data utilized for the research was the diffusion output. After the 500 raw data points from each line scan were entered into the program, a flat (specifically not near the area of diffusion) sample of the line

scan was chosen to analyze for the standard deviation of the sample. After a baseline standard deviation was established, non-horizontal data points were trimmed from both ends of the line scan. The points were removed to “zoom in” on the area of interest, the transition in the seal area.

To use the SAS© program to measure diffusion distance, four variables were initially estimated. The four variables represent the x and y values of two coordinate points. The first estimate was the “low side” baseline x-ray counts per second. The low side baseline was not zero because of contamination in the sample chamber. The low side baseline served as the first y-value estimate. The second estimate was the  $\mu\text{m}$ -value where the line transitioned from horizontal to a slope. This number was a value on the relative position axis, the first x-value estimate.

The third estimate was the “high side” x-ray counts per second. The high side counts per second measure was constant after the transition in the seal area. The high side value served as the second y-value estimate. The fourth estimate was the  $\mu\text{m}$ -value where the line transitioned to horizontal from a slope. This served as the second x-value estimate. These four values, coupled with the standard deviation of the data set, allowed the program to output a diffusion distance value. Each diffusion distance was correlated to its respective seal temperature for analysis in Excel 2013.

### **Analysis of Diffusion Data in Excel 2013**

After diffusion distances were determined for each temperature, the data was compiled into Excel 2013. Diffusion distances based on a sodium trace and diffusion distances based on an oxygen based trace were collected. After all data was in Excel, it was possible to compare the

diffusion distances to other measured variables. Graphs utilizing diffusion data were made comparing: sodium based diffusion distance to seal temperature, oxygen based diffusion distance to seal temperature, oxygen based diffusion distance to sodium based diffusion distance, seal strength to sodium based diffusion distance, seal strength to oxygen based diffusion distance, paired seal strength to sodium based diffusion distance, and paired seal strength to oxygen based diffusion distance. All graphs were given a linear correlation coefficient. Utilizing the graphs based on diffusion data, further analysis could be done.

### **Calculations Related to Electron Beam Interactions**

A measurement of interest, the x-ray range, is how far from within the sample the characteristic x-rays are generated. This measurement can be estimated based on the density of the sample, the critical ionization energy of the element of interest, and the voltage of the electron beam. The Anderson-Hasler X-Ray Range is presented in Equation 2. It is an equation to predict the depth of penetration of X-Ray microanalysis of an electron beam normal to a surface. (Goldstein, et al., 2003)

*Equation 2: Depth of Penetration Estimation in EDX*

$$R_x = \frac{0.064}{\rho} (E_0^{1.68} - E_c^{1.68})$$

$R_x$ = Depth of penetration of X-ray in  $\mu\text{m}$

$\rho$ = Density of Sample in  $\text{g}/\text{cm}^3$  or  $\text{g}/\text{cc}$

$E_0$ = Incident Electron Beam Energy in keV

$E_c$ = Critical Ionization Energy of Target Element in keV

Spatial resolution can also be estimated as shown in Equation 3. Spatial resolution in the x-ray microanalysis sense is the smallest interval measurable. Two points closer than the resolution distance cannot be distinguished as separate entities.

The equation has been estimated to be (NORAN Instruments, 1999):

*Equation 3: Spatial Resolution Estimation in EDX*

$$\text{Spatial Resolution} = .231 \frac{E_0^{1.5} - E_c^{1.5}}{\rho}$$

### **Initial Materials and Methods**

Several ideas were attempted before a final set of materials and methods were chosen. The first attempt was to use a fluorescent tag. A fluorescent tag would be traceable via light microscopy. However, the fluorescent tag would not react with the surface of a low percent acid copolymer (Nucrel® 0403) or a high percentage acid copolymer (Nucrel® 1202HC). The next attempt was to react the surface of Nucrel® 0403 with sodium hydroxide for tracing via EDX. The 0403 was not reactive enough for sodium to be detected on the surface. It was discovered that Nucrel® 1202HC had the appropriate reactivity with sodium hydroxide. The final polymers used (DuPont Nucrel® 1202HC and Dow 501i LDPE) were cast on Clemson's cast film line for the necessary thickness control. These attempts are discussed at length in the appendix.

## RESULTS

The results section is broken up into seven sub-sections. The first section, thickness profiles, shows how the flattest portion of each film was selected for seal testing.

Seal testing shows the results of the final, backed, seal test. The seal samples were manually laminated to metal foil tape to eliminate the influence of material extensibility. Sealing temperatures were chosen based on an initial exploratory seal curve. A high temperature (300°F) was also chosen to explore if diffusion changed substantially for this polymer system at high temperatures.

DSC results show the differential scanning calorimetry results of both films used in the study. Analysis of the major melting points on each DSC result helps to explain why the seal curve had an unexpected shape.

Electron microscope results show how the data collected from the electron microscope were used to collect diffusion data. The section also highlights some of the proof of concept work associated with ensuring the choice of materials was valid.

The EDX Resolution and Depth of Penetration show how the various settings and desired trace element affected both the depth from which the x-ray originates and resolution. The depth of penetration was calculated to be shallow, which is desirable since the trace ion is at the surface. However, the resolution of the EDX measurement is characteristically low.

Diffusion analysis shows how the results from the scanning electron microscope were used in conjunction with the seal curve results. The results of the diffusion distance vs. seal



temperature work were not as expected, which could have been caused by a number of reasons. Some of the reasons are outlined at the end of the results section.

The section about the revisit of the 220°F temperature setting with paired samples is an effort to explain the shape of the seal curve. It is also an effort to see if any trends appeared when samples were paired. To make a paired sample, two specimens (2.5 cm (1 inches) for seal strength testing, and 1.3 cm (0.5 inches) for SEM testing) were cut from the same 5.1 cm (2 inches) wide seal section. All samples tested besides the four paired samples highlighted in the revisit of 220°F section were unpaired.

### Thickness Profiles

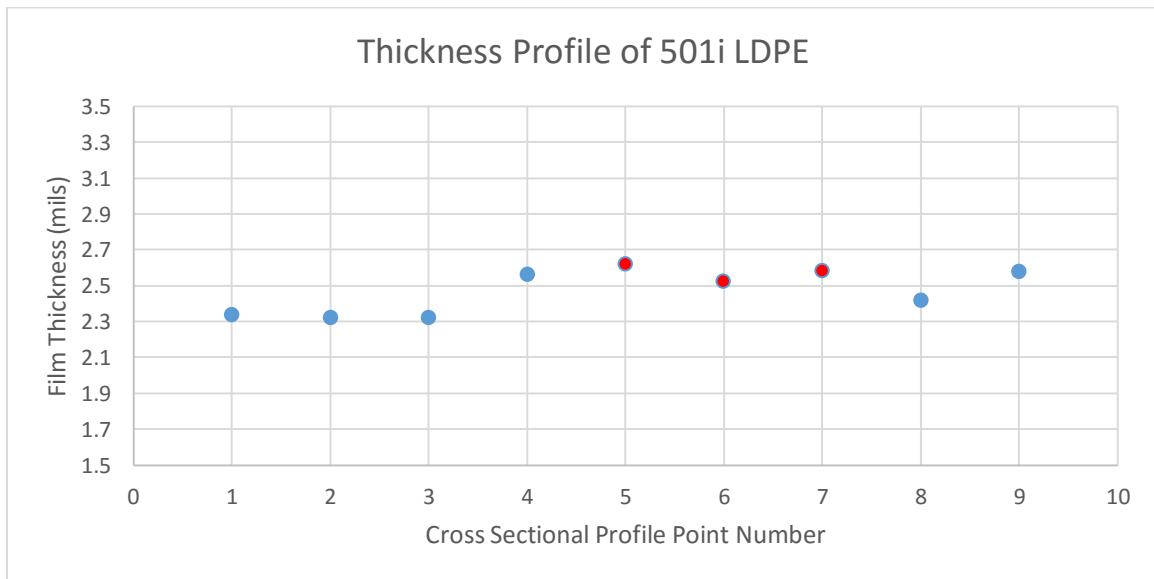

Figure 34: Thickness Profile of 501i LDPE Used in Study

Figure 34 shows the thickness profile of the cast LDPE. Points 5-7 were chosen to use in the study because they contained the flattest 3.8 cm (1.5 inches) cross section of the film. Points 5-7 have been highlighted in red. The two edge beads were not included in the cross sectional profile measurements, as the edge bead portion of the film was considered waste.

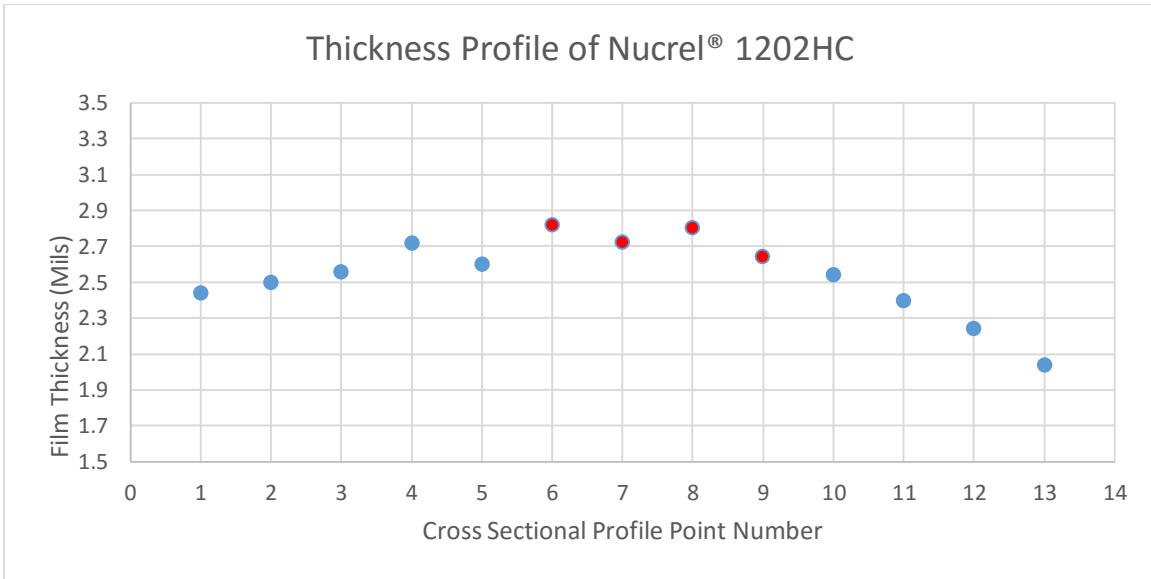

Figure 35: Thickness Profile of Nucrel® 1202HC Used in Study

Figure 35 shows the cross sectional profile of the Nucrel® 1202HC. Points 6-9 were chosen to use in the study because they contained the flattest 3.8 cm (1.5 inches) cross section of the film. Points 6-9 have been highlighted in red. The two edge beads were not included in this sample either.

## Seal Curves

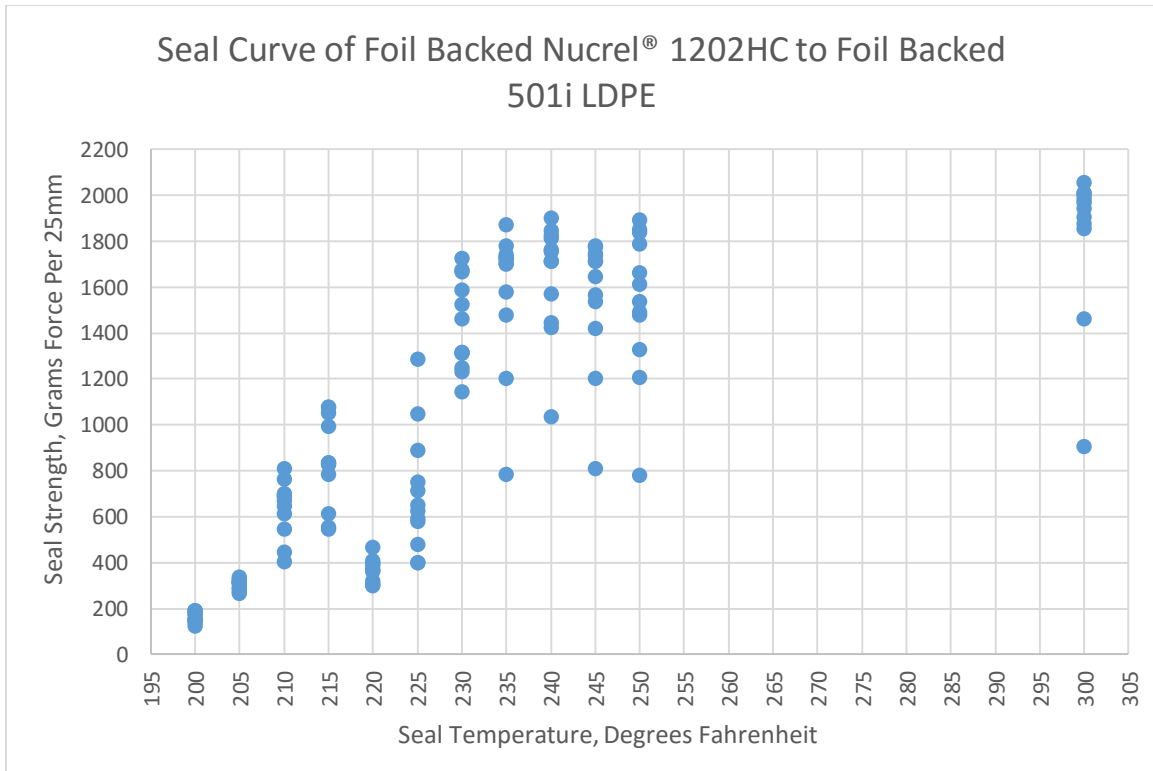

Figure 36: Seal Curve Results of Nucrel® 1202HC Poly(ethylene-co-methacrylic acid) Sealed to Dow 501i LDPE

Figure 36 shows unedited results from the seal test. Each temperature consists of 12-13 data points.

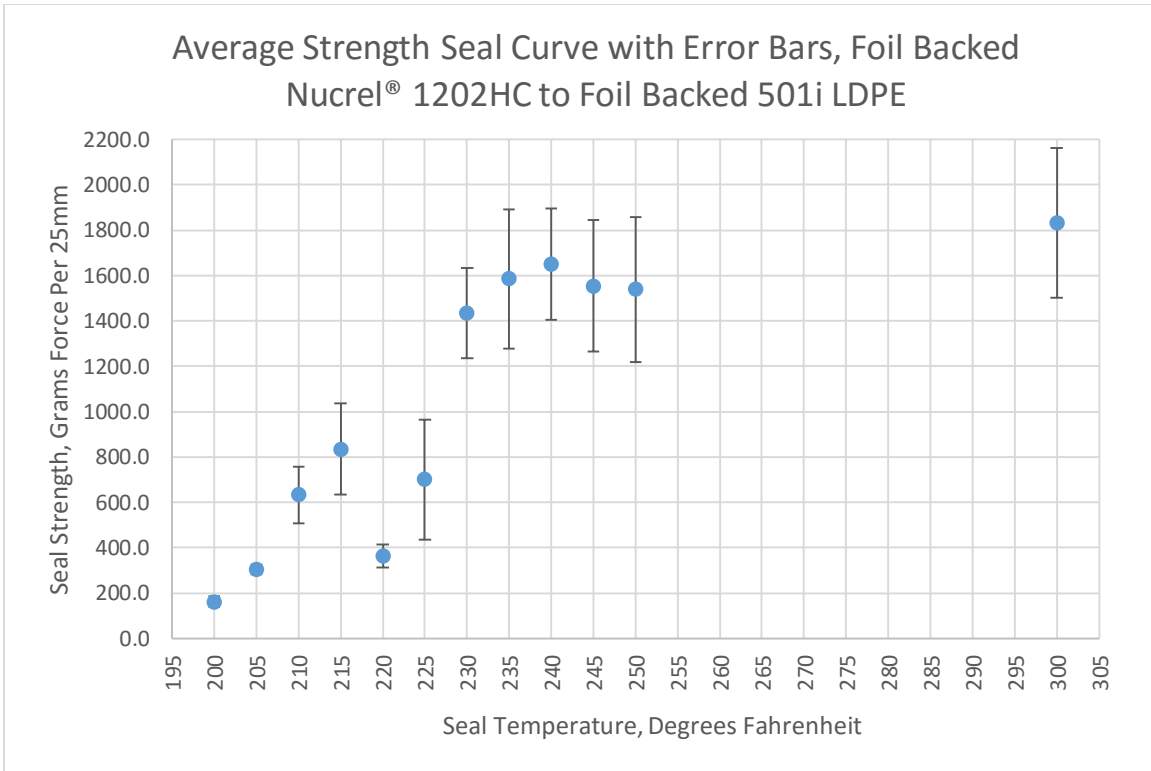

Figure 37: Averaged, with Error Bars, Seal Curve Results of Nucrel® 1202HC Poly(ethylene-co-methacrylic acid) Sealed to Dow 501i LDPE

The data to generate Figure 37 were the average of the data from Figure 36. The values for the error bars were generated with the STDEV.S function in Excel 2013. The error bars used in this work represent  $\pm 1$  standard deviation. Seal strengths representing 200°F and 205°F do not appear to have error bars at this scale, as their standard deviation is small.

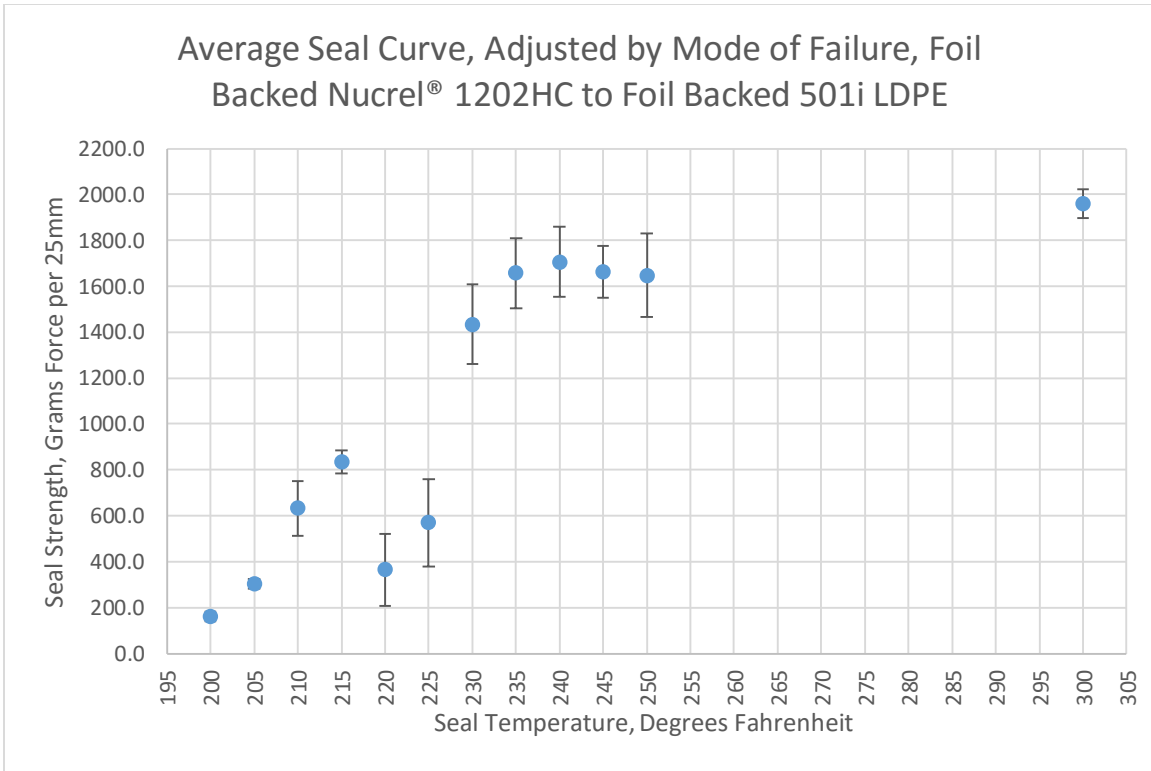

Figure 38: Seal Curve Results in Fahrenheit Adjusted by Mode of Failure, Averaged, with One Standard Deviation Error Bars

The data to generate Figure 38 were the data from Figure 36. The data were adjusted by removing points not matching the predominant mode of failure, then averaged. The predominant mode of failure was chosen for each temperature. Both peelable and fusion seals are possible when making a seal curve because of the different levels of energy (temperature) put into the seal can cause different degrees of polymer chain motion. For every temperature most of the seals were peelable so fusion numbers were excluded.

The values for the error bars were generated with the STDEV.S function. It is important to note that the shape and values of the curve experienced minimal change when the data were adjusted between Figure 37 and Figure 38, however the standard deviation at each point

became smaller. Seal strengths representing 200°F and 205°F do not appear to have error bars at this scale, as their standard deviation was small.

This seal curve in Figure 38 is not a typical seal curve. A typical seal curve would have not dropped between 215°F and 230°F. It would have continued approximately in a line between the 215°F and 230°F points. The dip occurred because of the variation in melting temperatures between the two polymers. The melting of the Nucrel portion of the seal interface absorbed a portion of the energy applied to the seal. This will be discussed further in the DSC section.

### DSC Curves

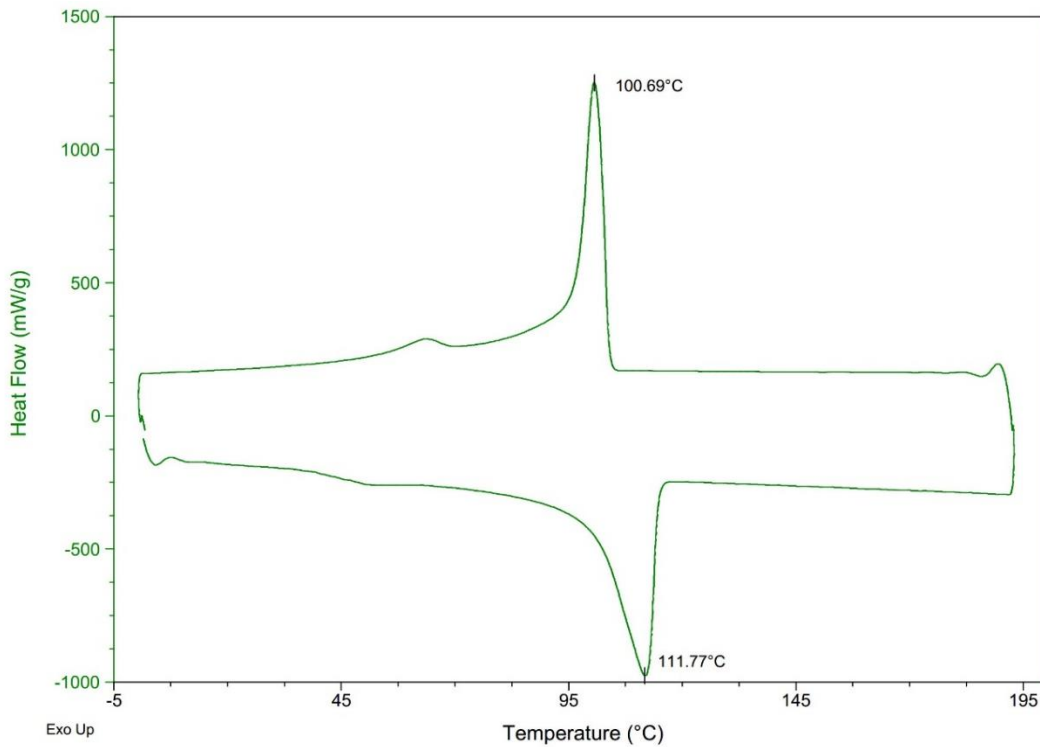

Figure 39: Differential Scanning Calorimetry Result from Dow 501i LDPE

Figure 39 is a DSC result of the 501i LDPE used in the study. The film was first cast, then analyzed via DSC. It is important to note the 111.77°C (233.2°F) temperature reading near the bottom of the figure. This is the melting point peak of the polymer. The 100.96°C (213.7°F) temperature marking near the top of the figure is the peak of the crystallization from the melt. This is the first heating and the first cooling of the material. This is an expected result, as this polymer has no additives. The second heating and the first cooling of the material are detailed in Figure 42.

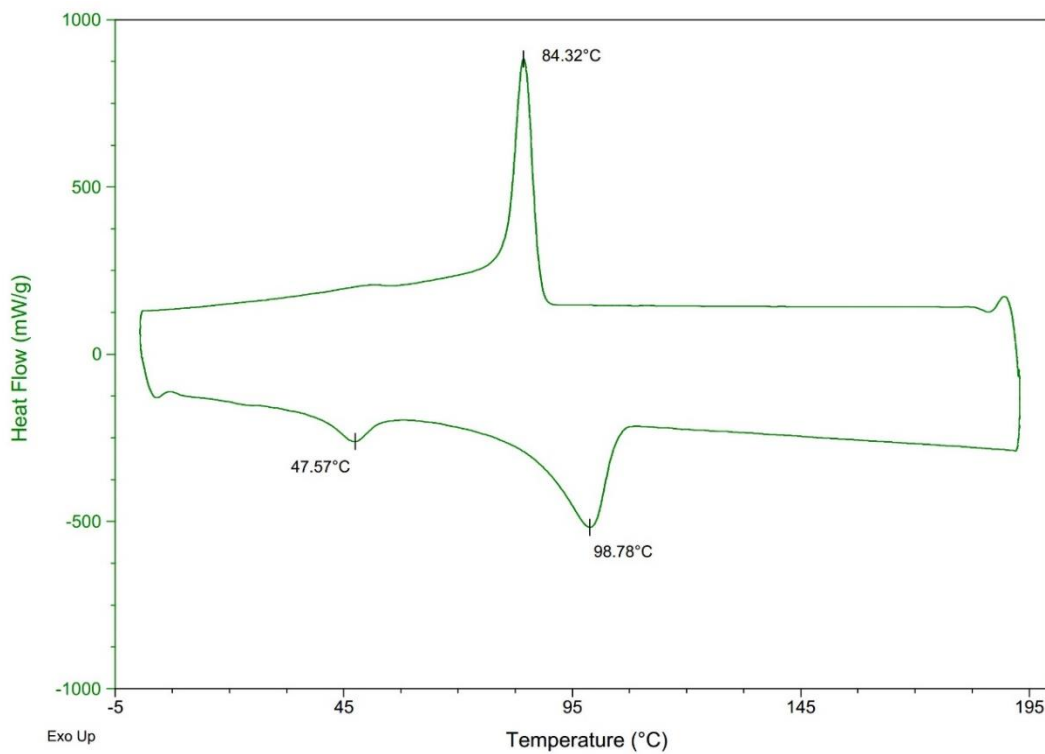

Figure 40: Differential Scanning Calorimetry Result from DuPont 1202HC Poly(ethylene-co-methacrylic acid)

Figure 40 shows a DSC result of 1202HC. The 47.57°C (117.6°F) peak is a minor endothermic point. The main melting point peaks at 98.78°C (209.8°F). A crystallization from the

melt point peaks at 84.32°C (183.8°F). It is interesting to note that, in Figure 38, there is a drop in the seal strength which correlates to the melting temperature of the 1202HC. Figure 40 is the first heating and the first cooling of the material. The second heating and the first cooling of the material is detailed in Figure 42. The minor melting point in Figure 40 is unexpected. It could be attributed to the melting point of the methacrylic acid copolymer. However, this is unlikely as the minor melting point is not present in the second heating (Figure 42).



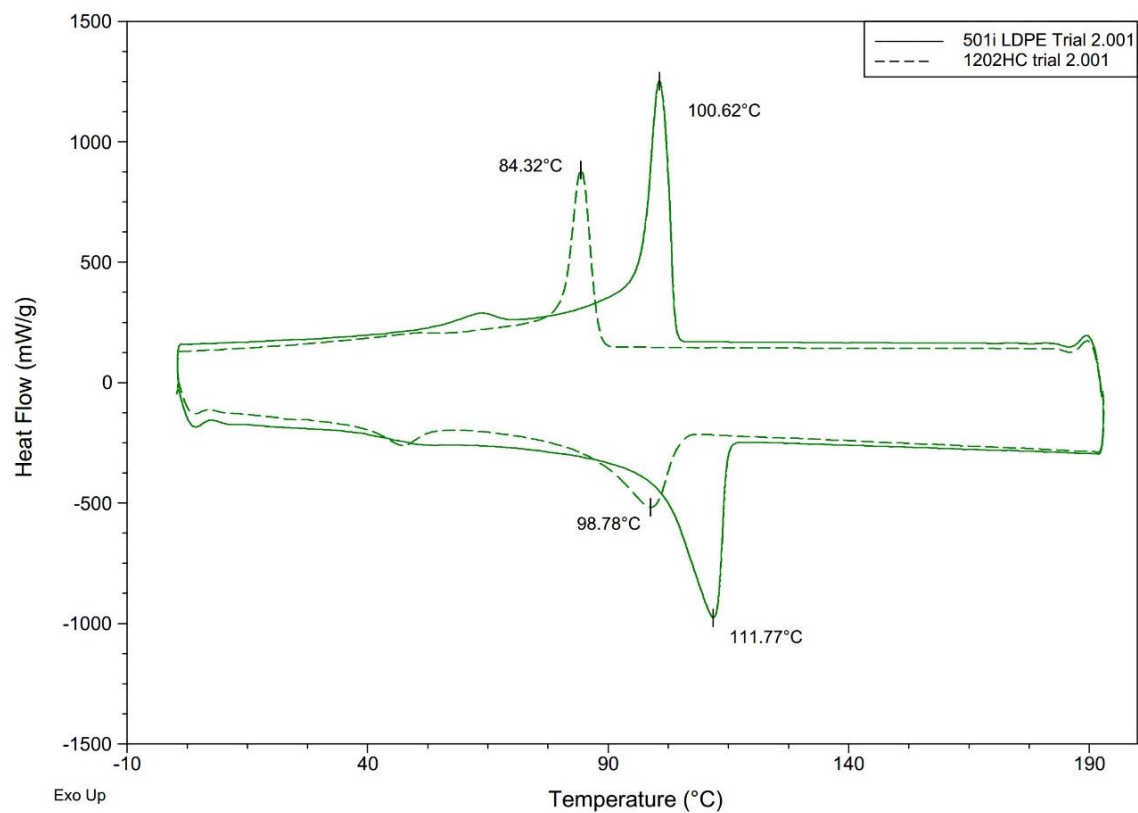

Figure 41: Differential Scanning Calorimetry Overlay of Nucrel® 1202HC and 501i LDPE First Heating and First Cooling

Figure 41 shows a comparison between the DSC curves present in Figure 39 and Figure 40. It is interesting to note that the dip in seal strength in Figure 38 corresponds to the area between the two melting points of the materials. Again, the melting point peak of the Nucrel® 1202HC is 98.78°C (209.8°F) and the melting point peak of the 501i LDPE is 111.77°C (233.2°F).

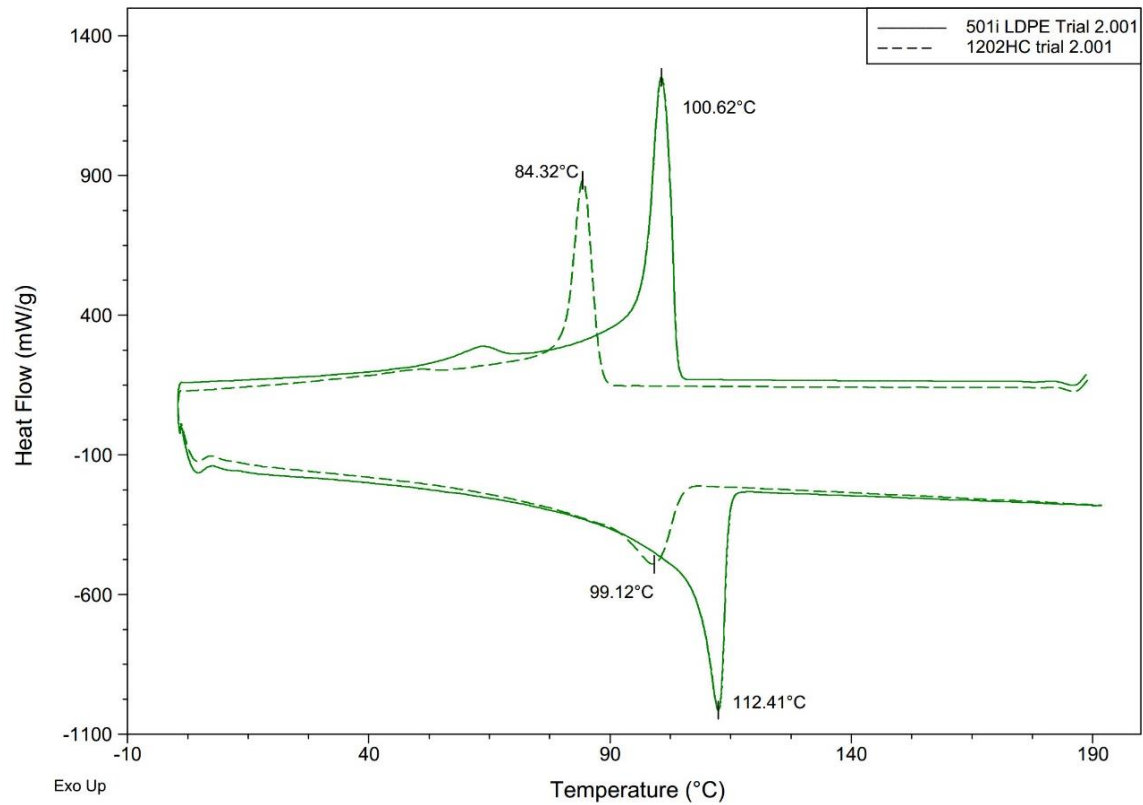

Figure 42: Differential Scanning Calorimetry Overlay of Nucrel® 1202HC and 501i LDPE First Cooling and Second Heating

Figure 42 shows the second heating and the first cooling of the materials. The melting points of the materials have both shifted slightly higher. The minor endothermic point in the Nucrel® 1202HC has also disappeared. Both of these factors can possibly be attributed to the slower cooling rate of the materials when they were cooled in the DSC versus when they were cast. The slower cooling in the DSC allows for more or larger crystals to form in LDPE.

## Electron Microscope Results

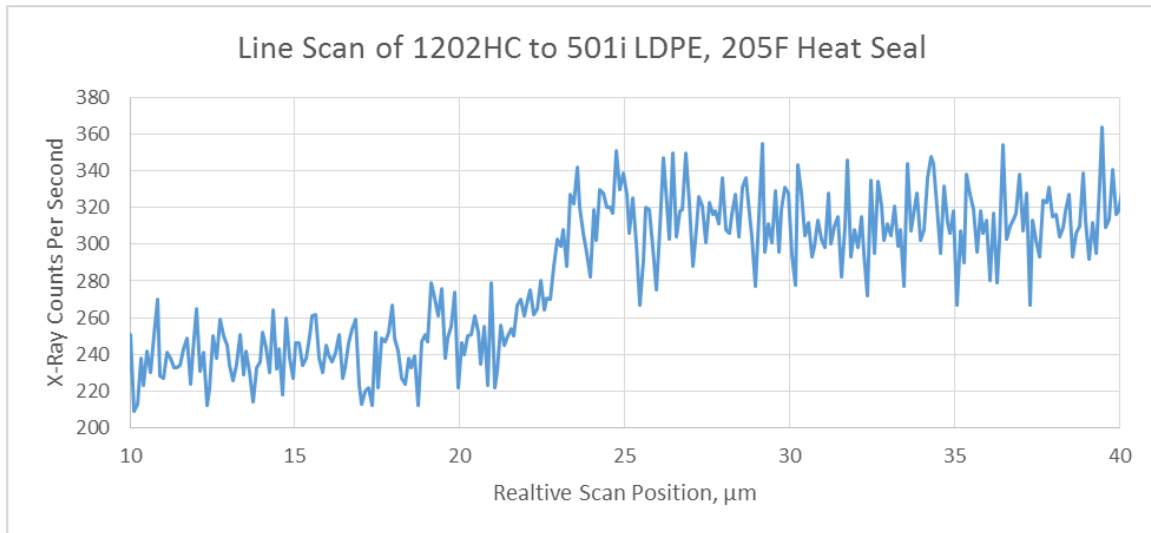
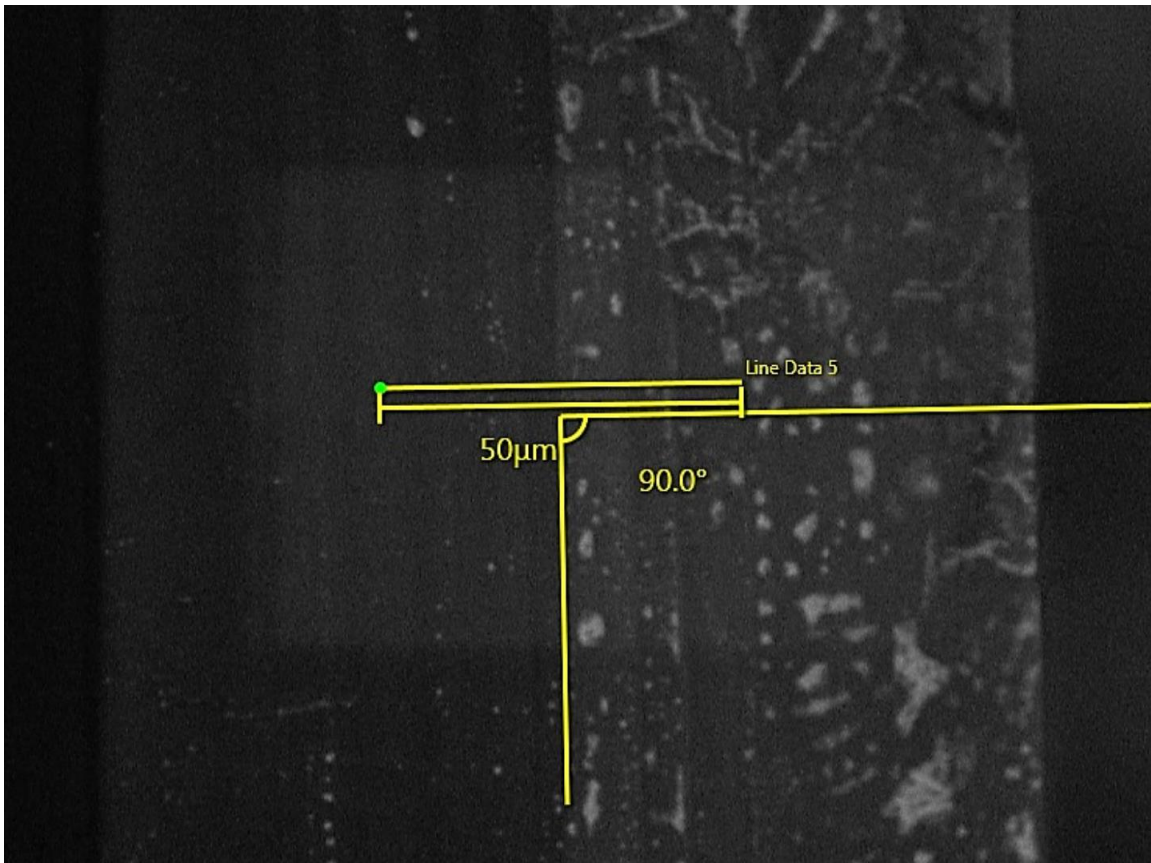

Figure 43: Energy Dispersive X-Ray Analysis Line Scan Result, Sodium Scan

Figure 43 shows an energy dispersive x-ray analysis (EDX) result with the raw data connected by straight lines. This type of result is called a line scan. It is a compilation of 500 data points collected across a 50μm line. The line is perpendicular to the seal interface as shown in Figure 44. The property measured in the figure is the concentration of sodium ions in the sample. A low concentration of sodium ions indicates the presence of LDPE (shown on the left side of the scan). A high concentration of sodium ions indicates the presence of reacted 1202HC (on the right side of the scan). The slope of the line between the two flat regions can be measured and interpreted as a seal diffusion. For the duration of sample analysis, the Nucrel® side of the seal interface was kept on the right side of the scan.

It is important to note that all EDX traces were based on elements added to the surface of the samples after sealing. Before sealing and soaking in NaOH, neither oxygen nor sodium were present in detectable quantities on the surface of either type of film.



*Figure 44: Annotations made before Line Scan*

Figure 44 shows the annotations made with the EDX analysis software before a line scan was created. The 90.0° reading is a line drawn down the middle of the seal interface, then drawn perpendicular to the seal interface. The line perpendicular to the seal interface was then used to properly align the 50µm caliper line. After the 50µm caliper line was drawn, the line scan line was drawn. The line scan in the figure is labeled “Line Data 5”.

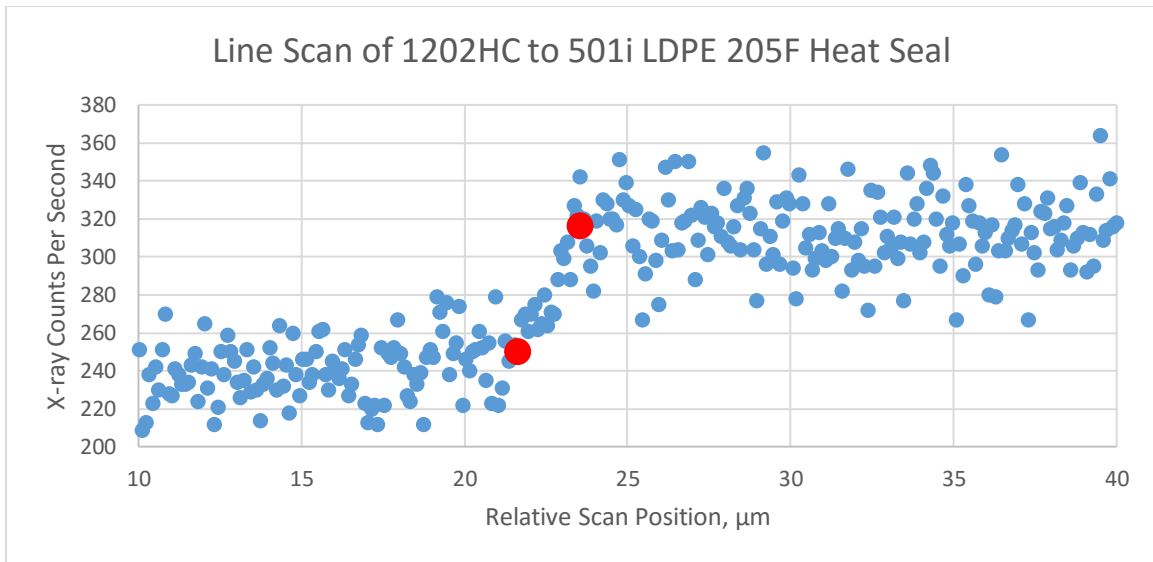
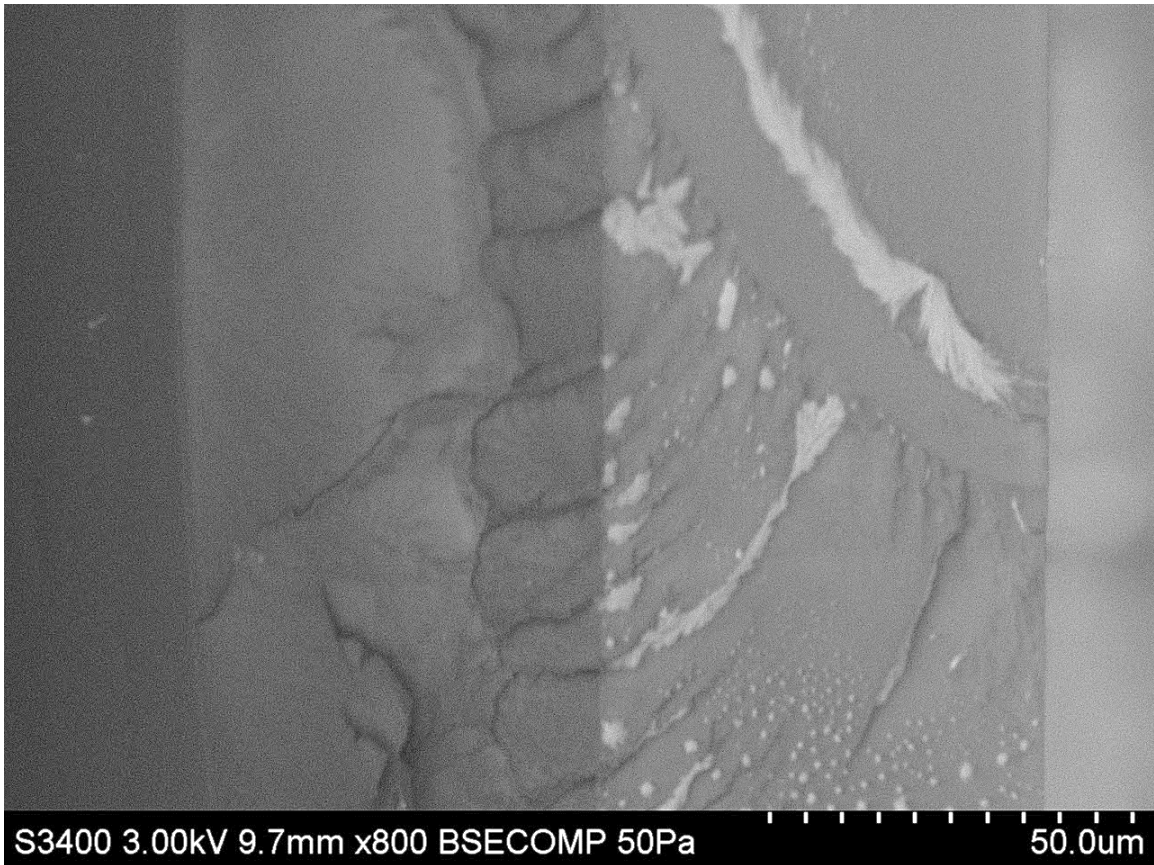

Figure 45: Line Scan Data with Diffusion Beginning and Ending Marked in Red

Figure 45 shows the raw data points of a line scan of sodium across a “tagged” seal interface. The “tagged” interface refers to the sodium ions present on the surface of the seal interface due to the reaction of the Nucrel® with sodium hydroxide.

The blue dots are the raw data points. The large red dots were chosen using the SAS® program mentioned in the previous chapter. The relative position between the two red points on the x-axis is used to interpret the diffusion distance. The relative position of the high side point is approximately 24μm. The relative position of the low side point is approximately 22μm. For Figure 45, the diffusion recorded was approximately 2μm. The slope between the two lines is not significant because the values of the y-axis change with each scan. If the x-ray counts per second were consistent between data sets, useful slope data could be generated.

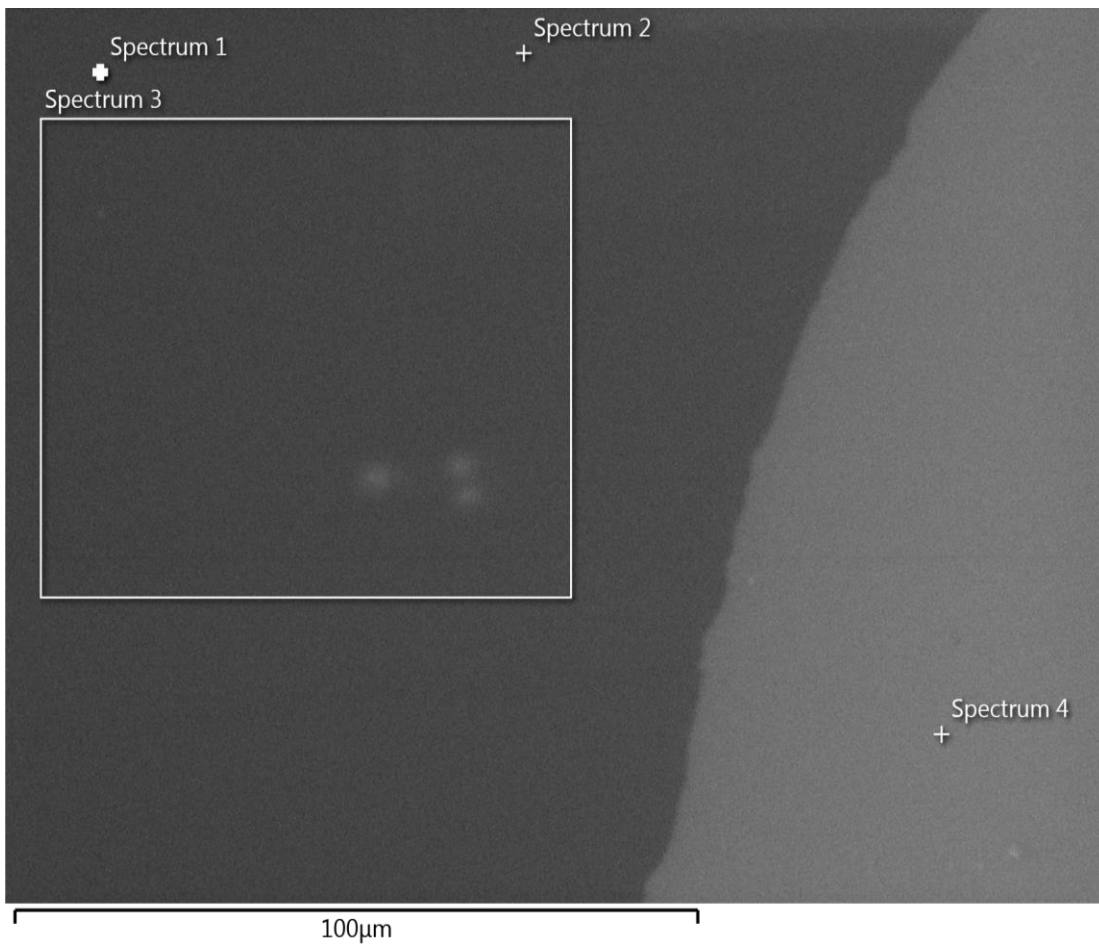

*Figure 46: Sodium Tagged Seal Interface*

Figure 46 is a the result of a back scattered grayscale electron image from a scanning electron microscope showing the seal interface between Nucrel® 1202HC and LDPE. All backscattered electron images are grayscale since backscatter measures electron reflection intensity, not light. The right side of the image is the Nucrel®. The left side of the image is LDPE. On the right side of the image, there are several light gray sodium deposits. This is remaining sodium on the surface after tagging the surface with sodium hydroxide.

An area where there was not a sodium deposit was chosen for all line scans. This because in early testing, it was discovered that scanning over an area with a sodium deposit caused a bump in the line scan near the area of the seal interface. Any bumps in the line scan at

the seal interface render the line scan unusable, so areas without sodium deposits were chosen for scanning.



*Figure 47: SEM Image of the Surface of Dow 501i LDPE Not Exposed to NaOH*

Figure 47 is a the result of a back scattered electron image from a scanning electron microscope showing the surface of Dow 501i LDPE which hasn't been exposed to NaOH. The lighter region on the right of the image is ink from a permanent marker which was used as an aid in focusing the microscope on the surface of the film.

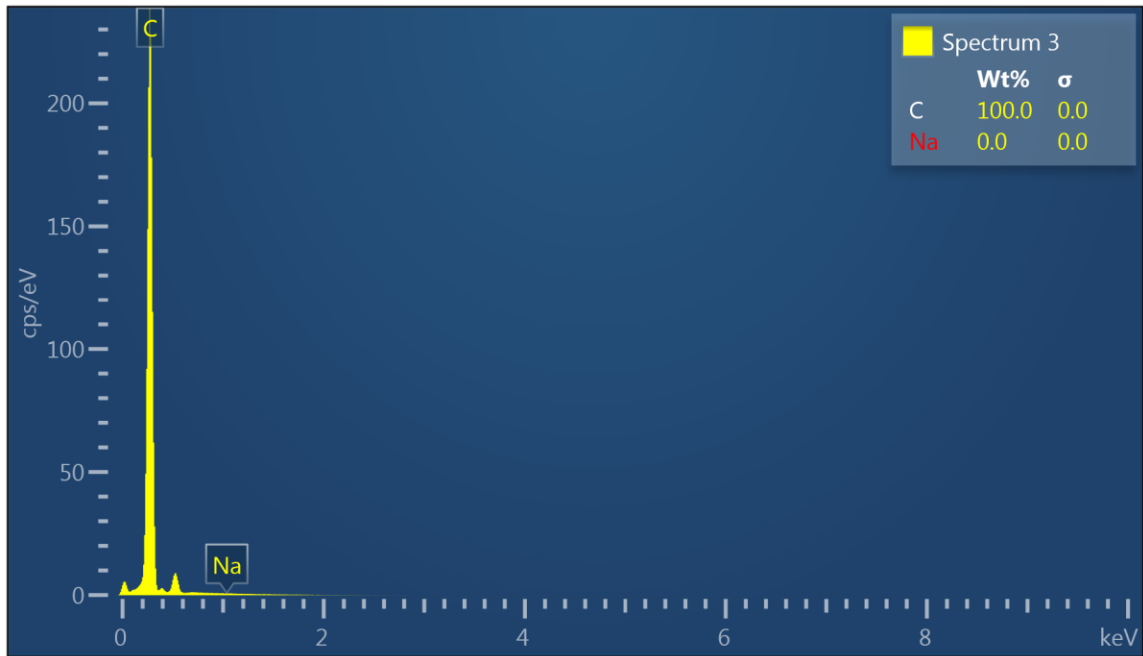
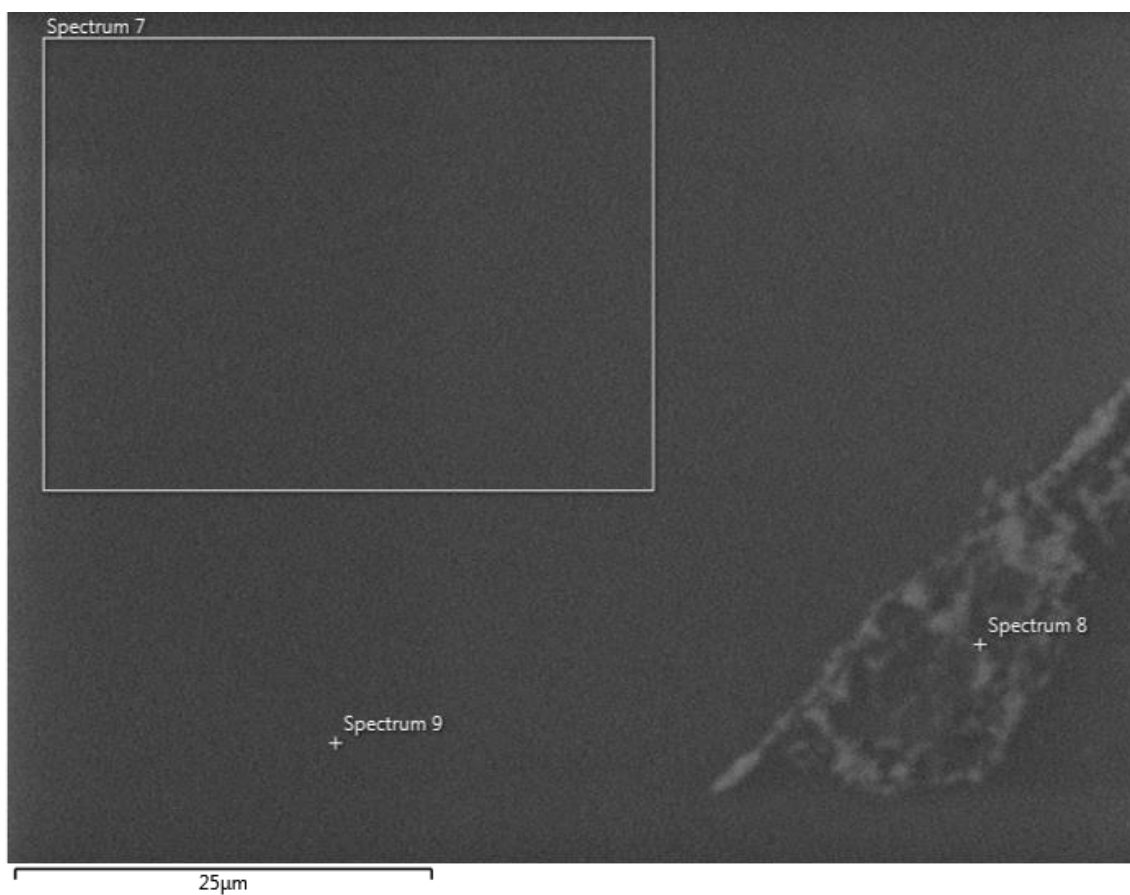

Figure 48: Result of Area Scan of Spectrum 3 in Figure 47

Figure 48 is the EDX result of the area scan of the area labeled spectrum 3 in Figure 47. This result shows there is no sodium present in an untagged sample of Dow 501i LDPE. This is important because an unknown source of sodium would introduce error.





*Figure 49: SEM Image of the Surface of Dow 501i LDPE Exposed to NaOH*

Figure 49 is the result of a back scattered electron image from a scanning electron microscope. The LDPE surface has been exposed to NaOH. Spectrum 8 is centered on a contaminant on the surface of the film. A contaminant is used to ensure that the SEM is focused on the surface of the film. There are no sodium ions present on the surface of the film. This is expected, as LDPE is a non-reactive film.

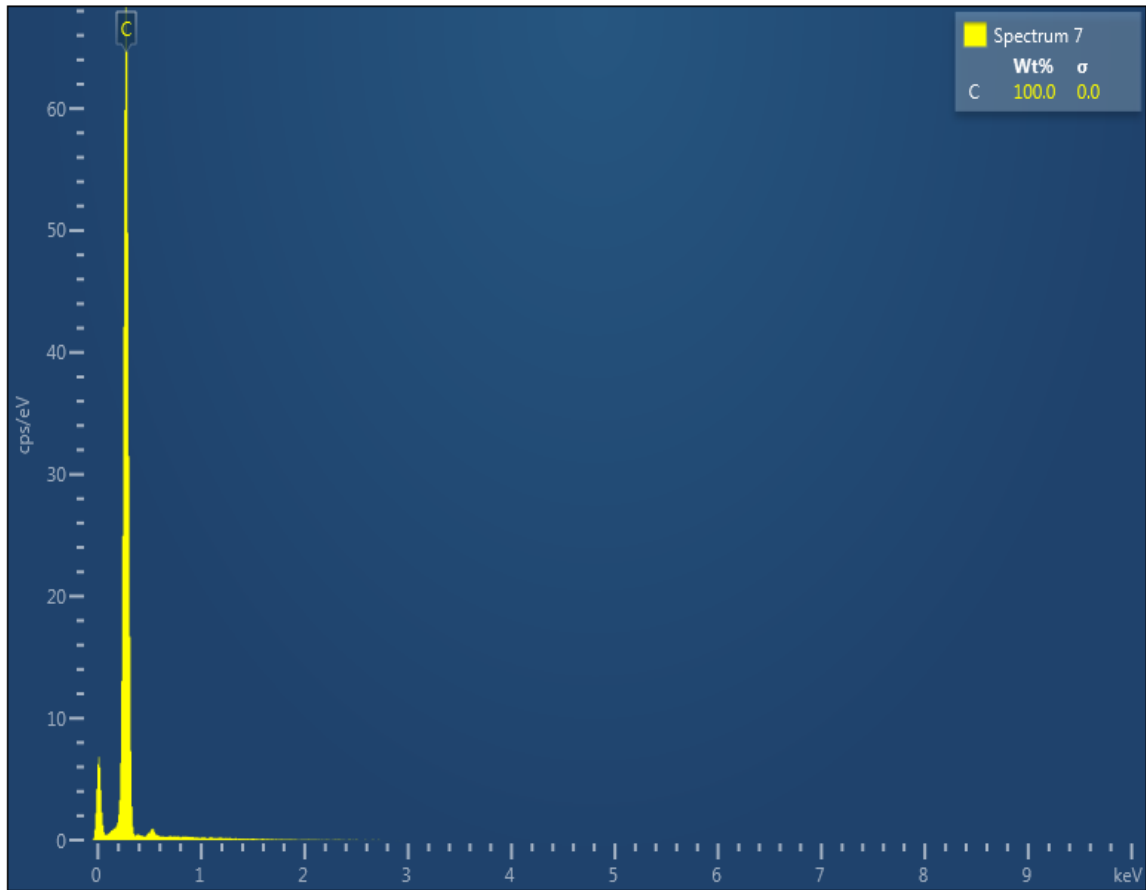

Figure 50: Result of Area Scan of Spectrum 7 in Figure 49

Figure 50 is the EDX result of the area scan of the area labeled spectrum 7 in Figure 49. The result shows that there is not sodium present on the surface of the LDPE after it has been exposed to NaOH.



*Figure 51: SEM Image of the Surface of DuPont Nucrel® 1202HC Not Exposed to NaOH*

Figure 51 is the result of a back scattered electron image from a scanning electron microscope. The surface has not been exposed to NaOH. The film is Nucrel® 1202HC. There is a contaminant present in the top right hand corner of the image to aid in focusing the microscope on the surface of the film. The contaminant contained no sodium. The unexposed Nucrel® 1202HC contained no sodium ions. This is important because an unknown source of sodium would introduce error.

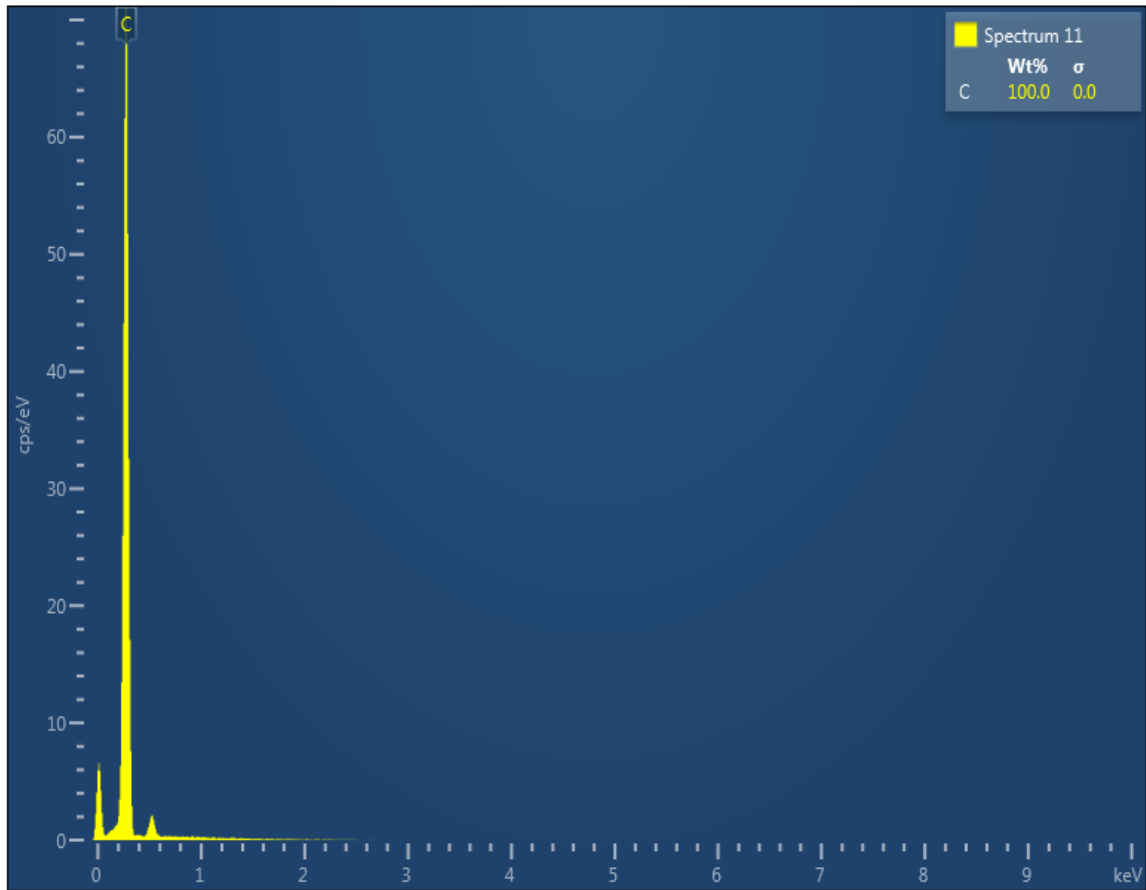
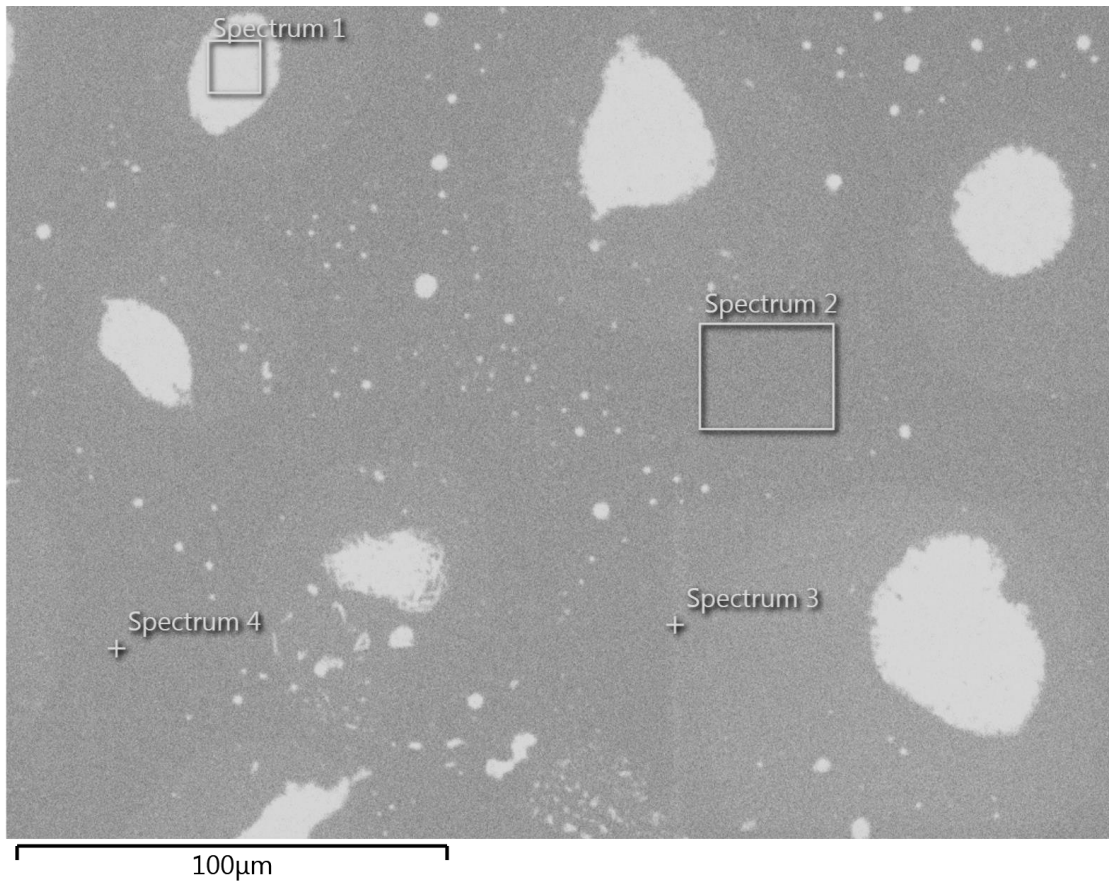

Figure 52: Result of Area Scan of Spectrum 11 in Figure 51

Figure 52 is the EDX result of the area scan of the area labeled spectrum 11 in Figure 51. The result shows that there are no sodium ions in an unreacted sample of Nucrel® 1202HC. This is expected based on the chemical properties of the film, as there are no sodium ions present initially.



*Figure 53: SEM Image of the Surface of DuPont Nucrel® 1202HC Exposed to NaOH*

Figure 53 is the result of a back scattered electron image from a scanning electron microscope. The surface of Nucrel® 1202HC has been exposed to NaOH. The lighter areas in the image are regions of high concentrations of sodium where the film was not fully washed. Since Nucrel® 1202HC is a random copolymer of methacrylic acid and polyethylene, there is a random distribution of reactive sites on the surface of the polymer.

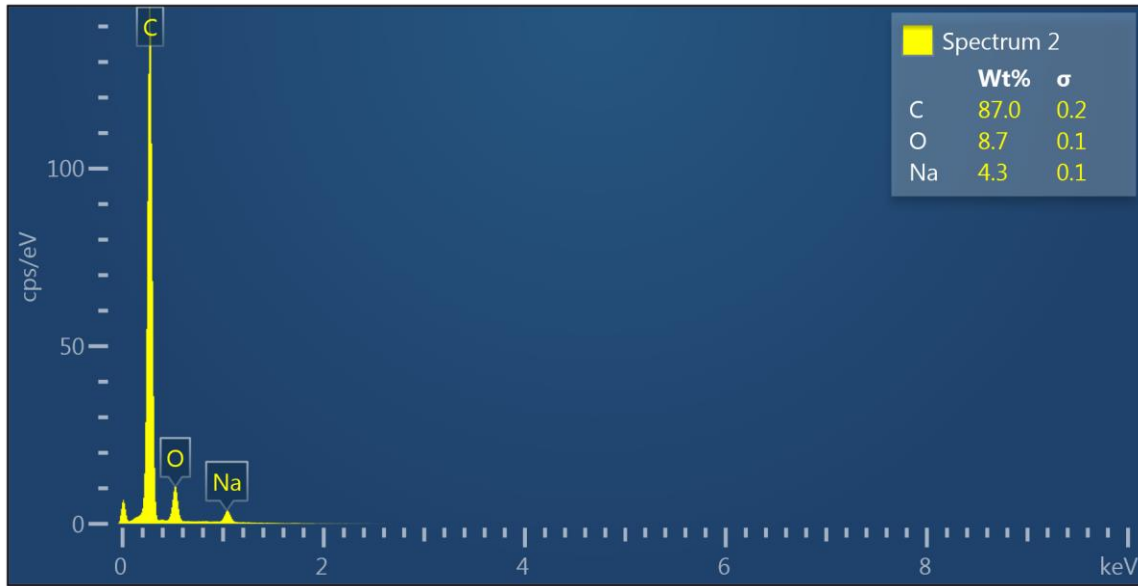

Figure 54: Result of Area Scan of Spectrum 2 in Figure 53

Figure 54 is the EDX result of the area scan of the area labeled spectrum 2 in Figure 53. The area scan shows a concentration of sodium because the surface of the film was reacted with sodium hydroxide. The concentration of sodium on the surface of the film is 4.3% by weight. Considering that Nucrel® 1202HC is 11.5% methacrylic acid by weight, this is a logical value because, based on the total weight of the methacrylic acid linkage, only a portion of the methacrylic acid group is reactive. Of that reactive portion, only some of the sites will be available to react at the surface of the film. Of those sites at the surface, approximately half will have the correct orientation of the acid group to be reactive (Kimmel, 2015).

#### EDX Resolution and Depth of Penetration

A measurement of interest, the x-ray range, is how deeply within the sample the characteristic x-rays are generated. This measurement can be estimated based on the density of the sample, the critical ionization energy of the element of interest, and the voltage of the

electron beam. As it applies to this research the depth of penetration equation is shown in Equation 4 (Goldstein, et al., 2003).

$R_x$  is the depth of penetration

$\rho$  (density) of DuPont 1202HC EMAA is 0.93 g/cc

$\rho$  (density) of Dow 501i LDPE is 0.922g/cc

$E_0$  (incident electron beam energy) is 3.00 keV

$E_c$  (critical ionization energy of target element) is 1.07 keV for sodium

*Equation 4: Anderson-Hasler X-Ray Range*

$$R_x = \frac{0.064}{(0.922 + 0.93)/2} (3.00^{1.68} - 1.07^{1.68})$$

$$\text{Depth of Penetration} = R_x = 0.036\mu\text{m}$$

Another estimate of interest is the spatial resolution equation. The complete equation was presented in the materials and methods section. Two points closer than the resolution distance cannot be distinguished as separate entities. The spatial resolution of the EDX measurement smallest measurable interval is (NORAN Instruments, 1999):

$$\text{Spatial Resolution for Sodium Detection} = .231 \frac{3.00^{1.5} - 1.07^{1.5}}{(0.922 + 0.93)/2}$$

$$\text{Spatial Resolution for Sodium Detection} = 1.02\mu\text{m}$$

$$\text{Spatial Resolution for Oxygen Detection} = .231 \frac{3.00^{1.5} - .532^{1.5}}{(0.922 + 0.93)/2}$$

$$\text{Spatial Resolution for Oxygen Detection} = 5.19\mu\text{m}$$

The best resolution achievable with a light microscope is 200nm (Australian Centre for Microscopy & Microanalysis, 2014). 1.02μm is 1020nm, and 5.19μm is 5190nm. It is interesting to note that the resolution of the EDX measurement is lower than the best achievable resolution of a light microscope.

### Diffusion Analysis

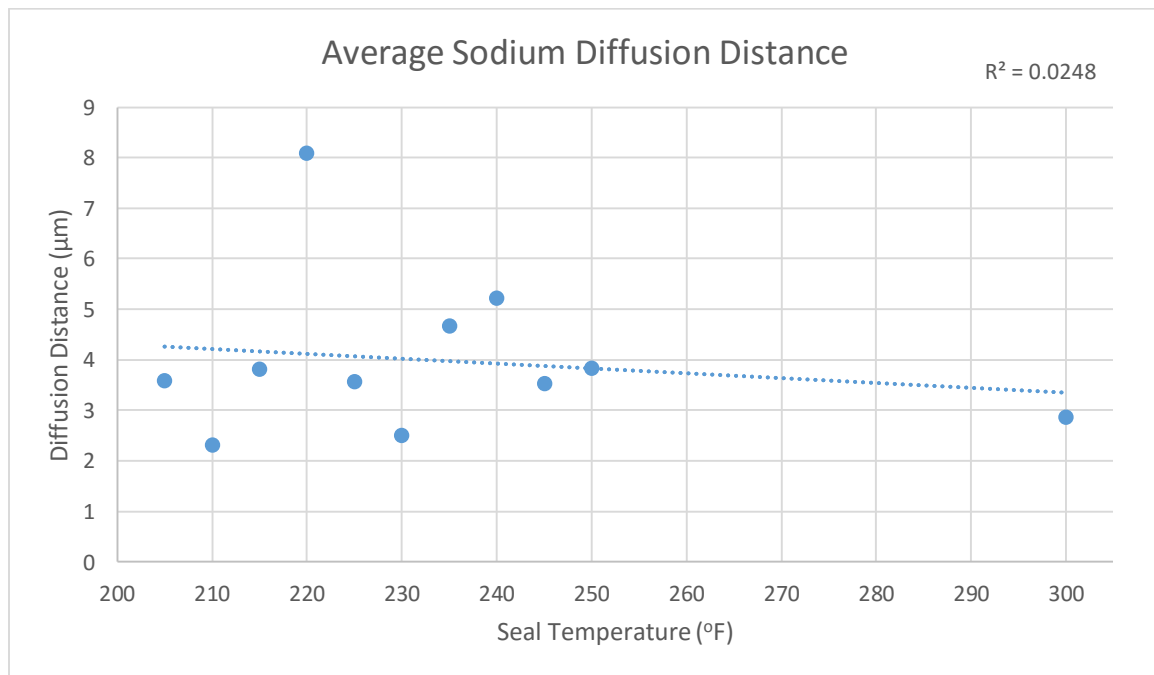

Figure 55: Average Sodium Based Diffusion Distance vs. Seal Temperature

Figure 55 shows the result of the average diffusion distance using sodium as a trace vs. seal temperature. The data were generated from a collection of line scans such as the scan in Figure 45. The R<sup>2</sup> value is 0.0248. This indicates that the data are not linearly correlated. For this polymer system, diffusion distance is not correlated with seal temperature. This does not agree



with previous findings. It was previously found, using a zinc ion trace, that diffusion distance at the seal interface increases as seal temperature increases (Cooper, 2014).

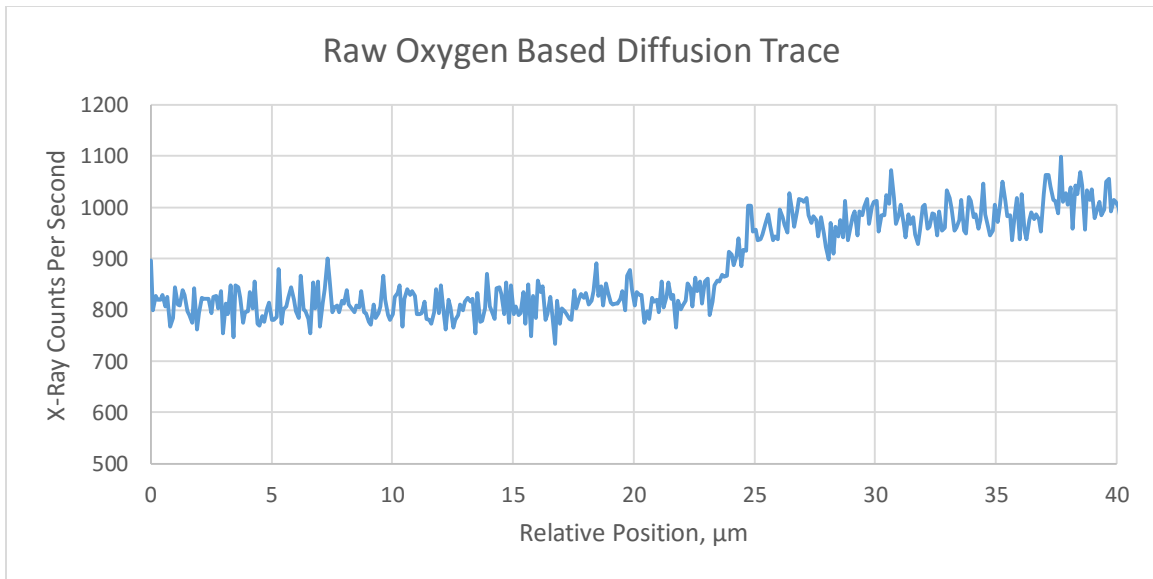

Figure 56: Raw Oxygen Based Diffusion Trace

Figure 56 shows a raw oxygen based diffusion trace. The baseline counts per second were higher for oxygen than they were for sodium. This could be due to the 50 pascal atmosphere left in the SEM analysis chamber. The oxygen based diffusion trace was analyzed with the same statistical analysis program as the sodium based diffusion trace.

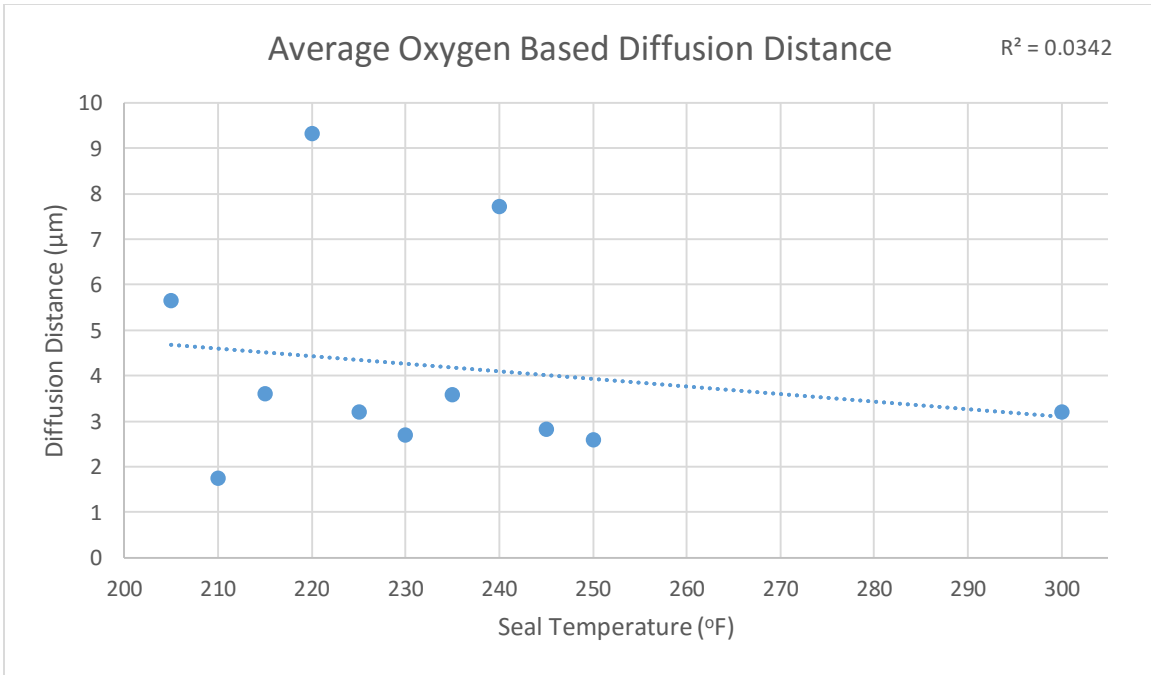

Figure 57: Average Oxygen Based Diffusion Distance vs. Seal Temperature

Figure 57 shows the result of the average diffusion distance using oxygen as a trace vs. seal temperature. There is a linear or slightly downward sloping diffusion line of best fit. The  $R^2$  value is 0.0342, which is similar to the  $R^2$  value in Figure 55. Using oxygen as a trace to quantify diffusion in heat seals appears to be a novel idea based on the difficulty encountered in previous studies (Cooper, 2014).

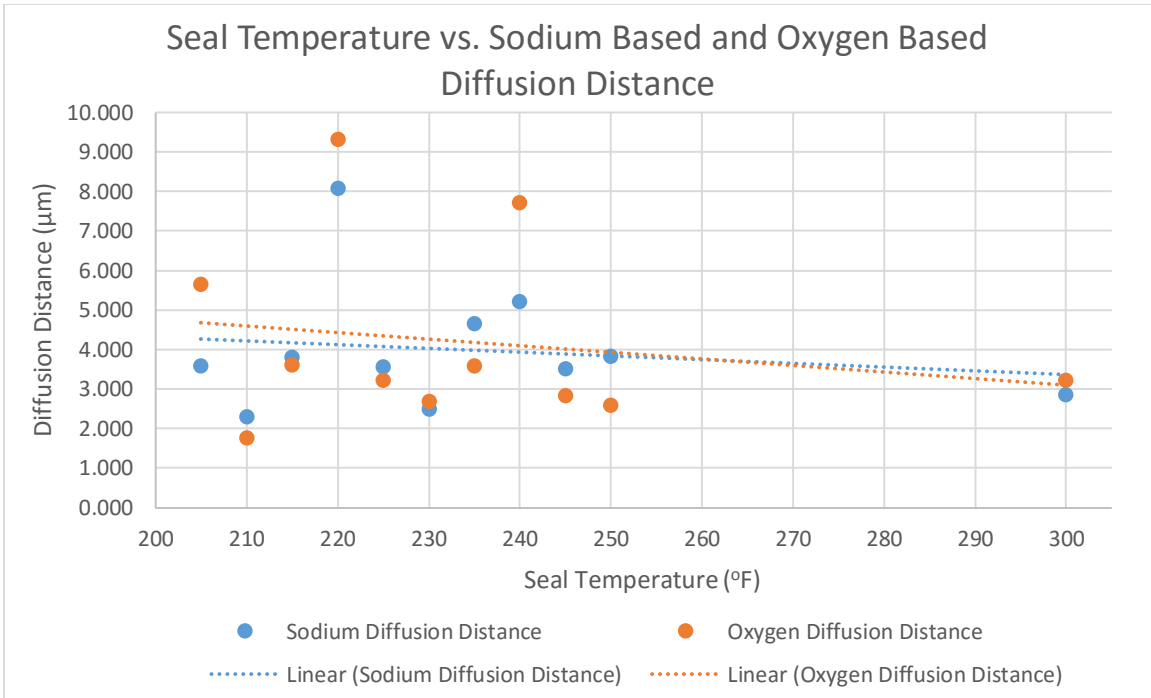

Figure 58: Sodium and Oxygen Based Diffusion Distance vs. Seal Temperature

Figure 58 is a combination of the data from Figure 55 and Figure 57. It shows that when measuring diffusion via a sodium or oxygen trace, there is limited difference between the two data sets.

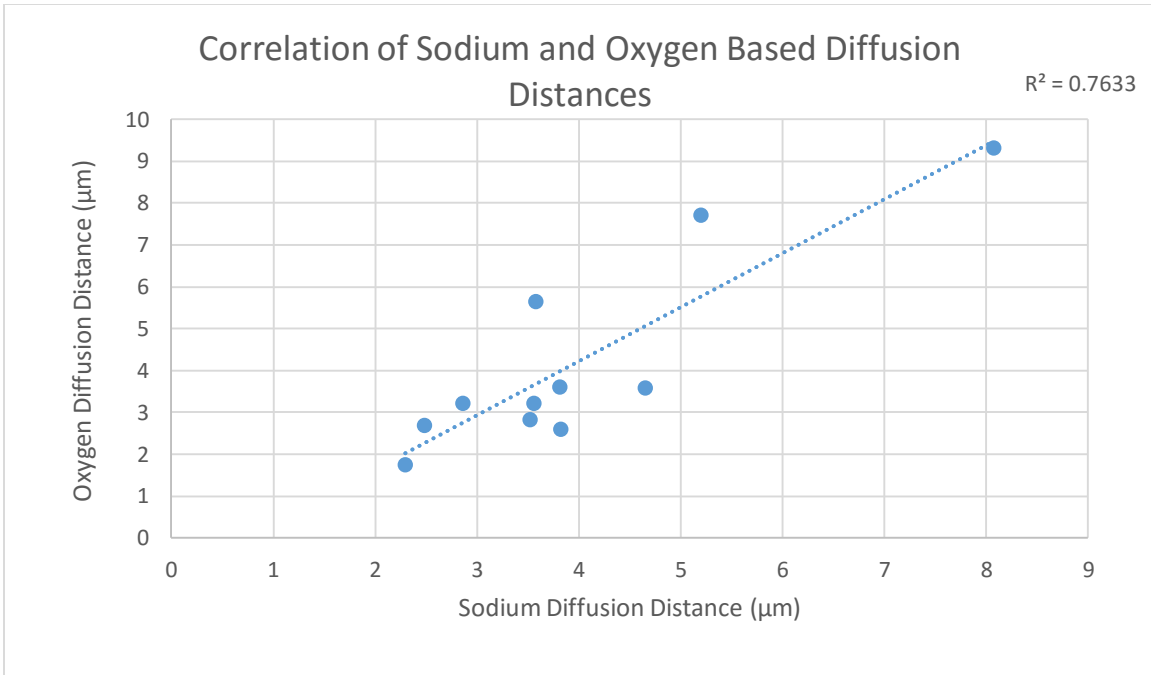

Figure 59: Correlation of Oxygen and Sodium Diffusion Distances by Seal Temperature

Figure 59 shows that the oxygen and sodium traces are correlated. The correlation is made by seal temperature. The seal temperatures are not in order, they are ordered by their diffusion distance. This figure, similar to Figure 58, is a different way of showing that the oxygen and sodium diffusion data are related.

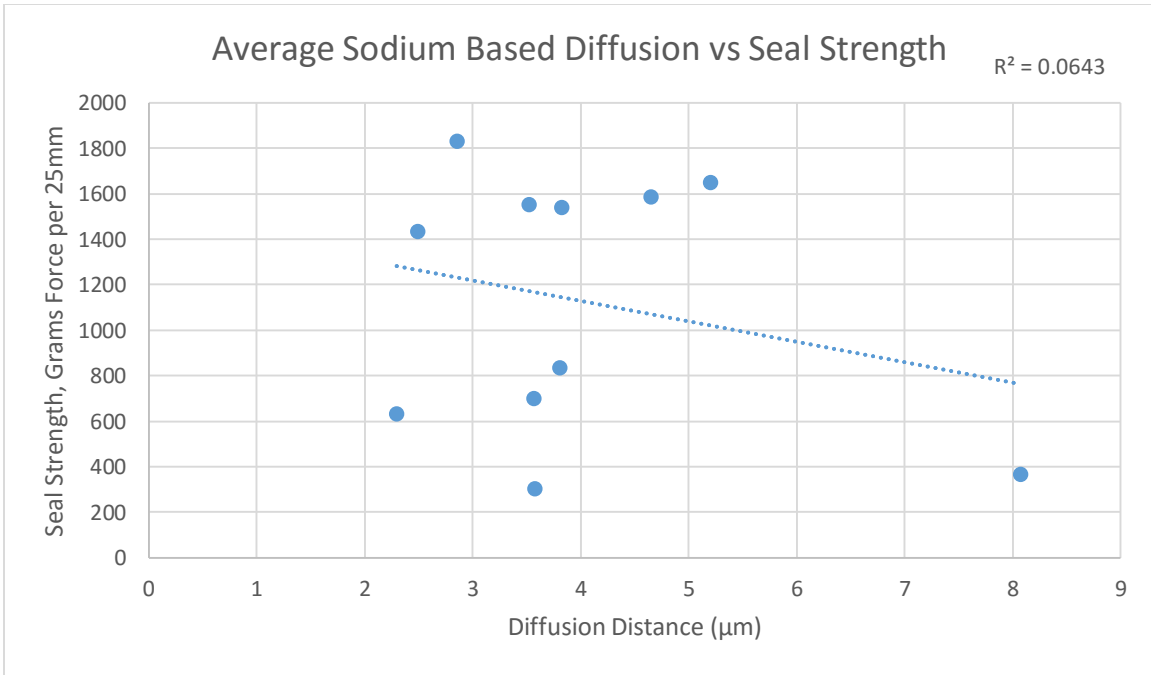

Figure 60: Seal Strength vs. Average Sodium Based Diffusion Distance

Figure 60 shows the average sodium diffusion distance vs the seal strength. The  $R^2$  value is 0.0643. This indicates that the data do not have a linear correlation. For this polymer system, seal strength is not correlated to diffusion distance

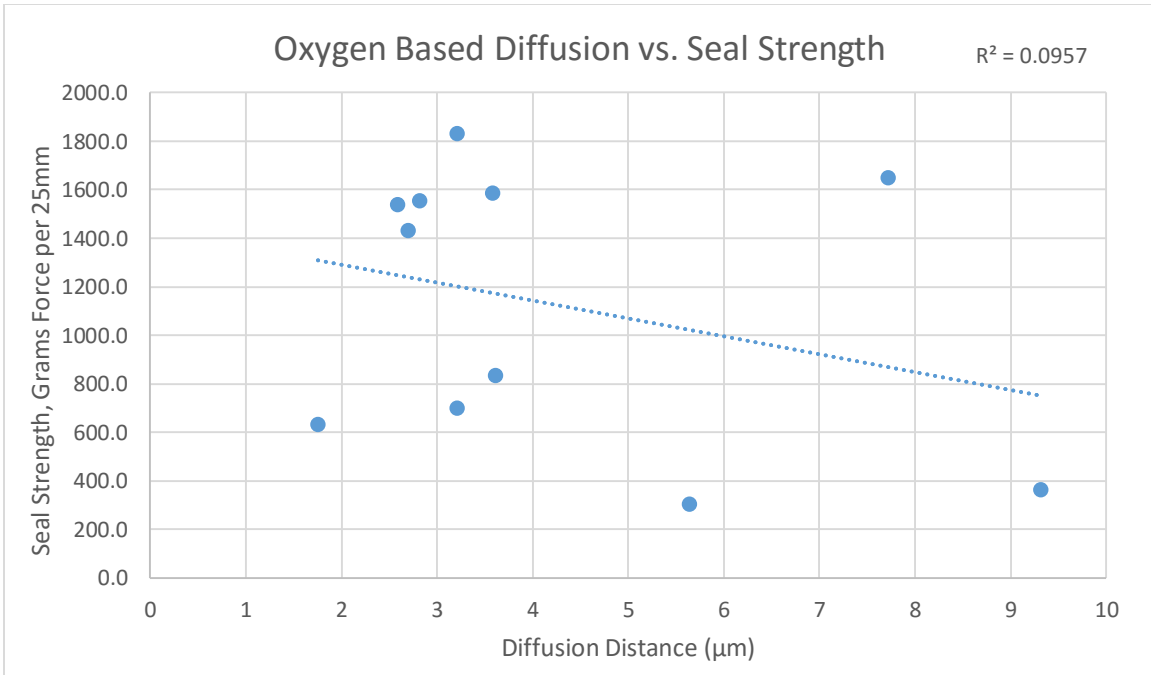

Figure 61: Seal Strength vs. Average Oxygen Based Diffusion Distance

Figure 61 shows the average oxygen based diffusion distance vs. the seal strength. The  $r^2$  value is 0.0957. This indicates that the data do not have a linear correlation.

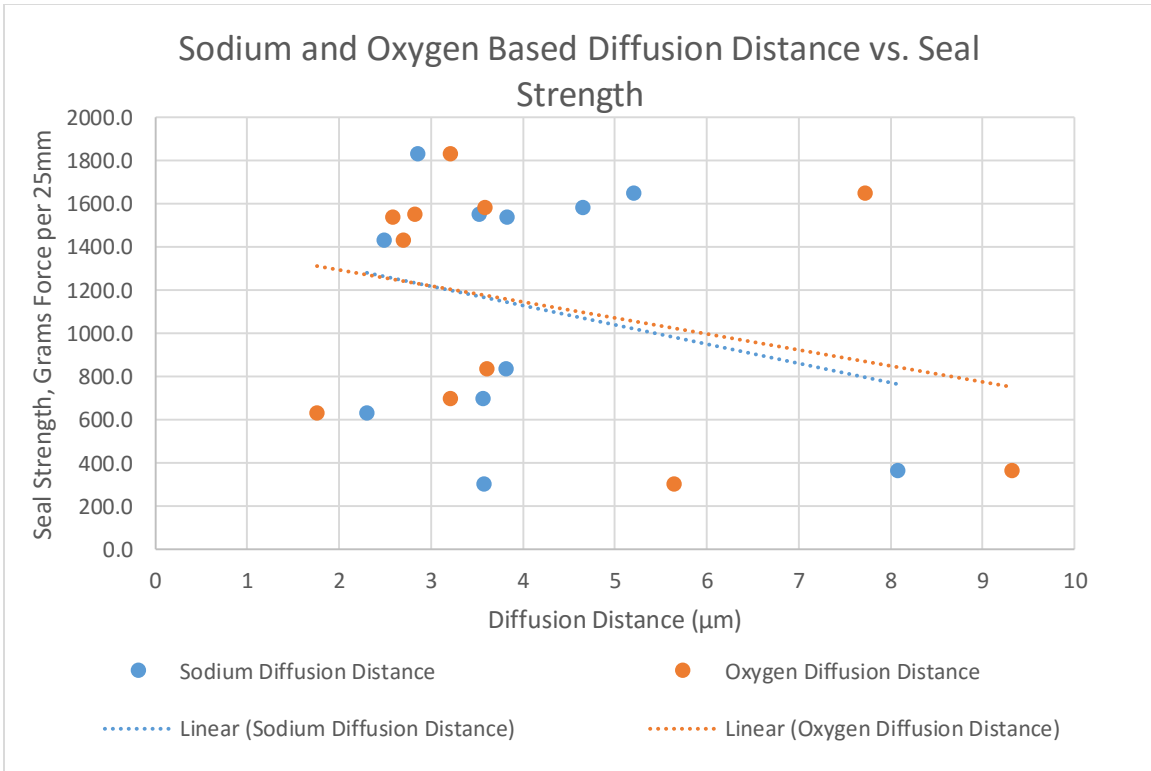

Figure 62: Seal Strength vs. Average Sodium Based and Oxygen Based Diffusion Distance

Figure 62 shows a combination of Figure 60 and Figure 61. This shows that when comparing seal strength to diffusion distance, the sodium and oxygen values are correlated. Previous research based on a zinc trace found a strong correlation between an increase in seal temperature and an increase in diffusion distance (Cooper, 2014).



## Revisit of 220°F Sealing Temperature with Paired Samples

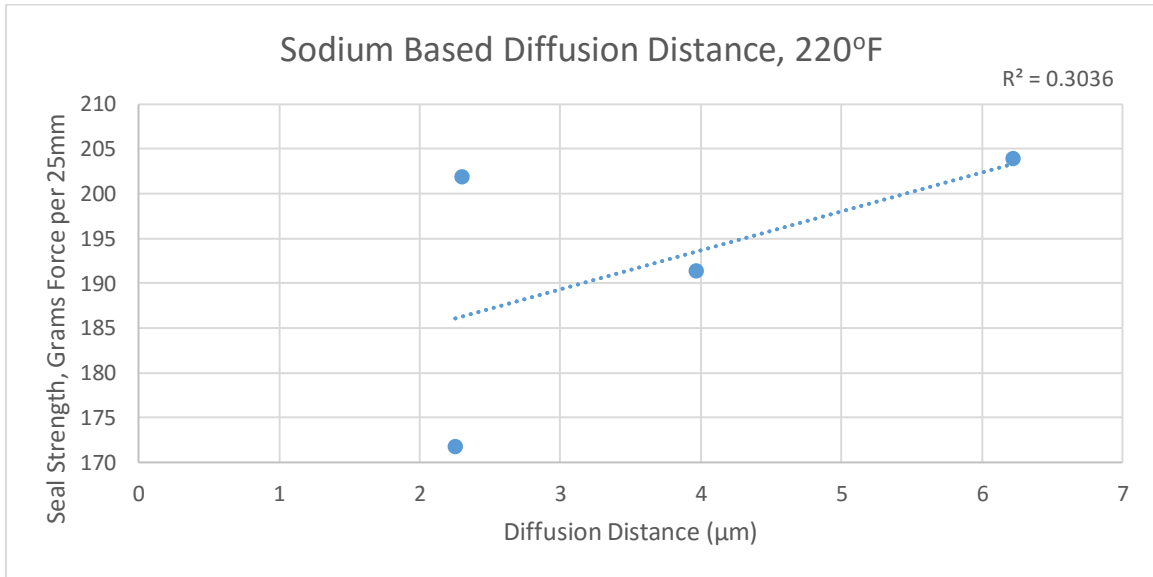

Figure 63: Sodium Based Trace of Diffusion Distance at 220°F Seal Temperature, Using Paired Samples

Figure 63 shows the sodium based diffusion trace result of a test performed with paired samples. Each diffusion distance and seal strength were taken from the same sample. There is a reasonable correlation,  $r^2=0.3036$ , from the data. It is important to note that the correlation of these data are higher than the correlations of the unpaired data. However, such a wide variation in diffusion distance with a relatively small change in seal strength was unexpected. When these data were averaged into a modified seal strength average vs. sodium based diffusion distance, no appreciable difference was noted.

In Figure 63, it was shown that paired samples had a  $R^2$  correlation of .3036. While this correlation is one of the stronger correlations seen in the study, it is important to note the variation of the data. Previously measured sodium based diffusion distances over the sealing temperature range from 205°F to 300°F ranged from 0.74μm to 16.27μm. Previously measured seal strengths over the seal temperature range of 205°F to 300°F were 264.4 gf/25mm to 2056.8

gf/25mm. This means that, in the paired samples where sodium was traced, there was a span of 1.68% of the total observed seal strength covering 25.6% of the span of total observed diffusion distance. In related research, a range in sealing temperatures from 180°F to 300°F generated a range in diffusion from 1.24μm to 7.82μm (Cooper, 2014). In the same related research, the range of seal strengths was 22.02 gf/25mm to 891.41 gf/25mm.

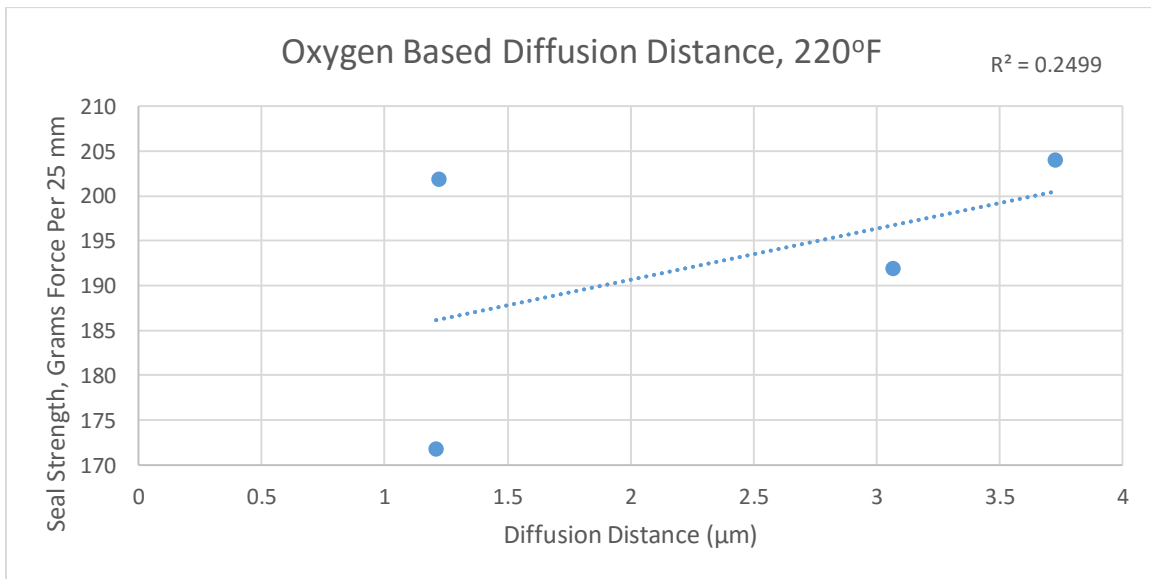

Figure 64: Oxygen Based Trace of Diffusion Distance at 220°F Seal Temperature, Using Paired Samples

Figure 64 shows the sodium based diffusion trace result of a test performed with paired samples. Each diffusion distance and seal strength were taken from the same sample. Such a wide variation in diffusion distance with a relatively small change in seal strength was unexpected. When these data were averaged into a modified seal strength average vs. oxygen based diffusion distance, no appreciable difference was noted. Previously measured oxygen based diffusion distances over the sealing temperature range of 205°F to 300°F ranged from 0.64μm to 16.4μm.

### **Potential Reasons Which Caused Unexpected Data**

Nucrel® 1202HC and 501i LDPE could have limited or unpredictable miscibility. Nucrel® is a copolymer of 88.5% low density polyethylene and 11.5% methacrylic acid. 501i LDPE is 100% low density polyethylene. The randomly distributed methacrylic acid groups could have caused the Nucrel® to have limited or unpredictable miscibility into the LDPE.

The EDX detector could have caused issues due to its limit of quantification when compared to its limit of detection. The “limit of quantification is the lowest concentration at which the analyte can not only be reliably detected but at which some predefined goals for bias and imprecision are met. The limit of quantification may be equivalent to the limit of detection or it could be at a much higher concentration” (Pry & Armbruster, 2008).

Another issue with EDX is that it is not specifically a surface analysis technique. The X-rays come from within the bulk of the sample when the electron beam interacts with the sample. In this case the target ion was localized to the surface of the sample. Even though steps were taken to minimize the penetration depth of the electron beam, the X-ray information was gathered from beneath the surface as well as at the surface of the sample.

The seal curve, as shown in Figure 38, was comprised of two major groups of data for this sealant system. This could have caused issues with the correlation to the diffusion distance. The correlation between the seal strength and the diffusion distance appears to be “split” in Figure 62 partially because of the unique nature of the seal curve in Figure 38. In Figure 38, the data points are grouped below 1,000 gf/25mm of seal strength and above 1,400gf/25 mm of seal strength.

Sample pairing is a technique which was shown to improve the correlation in the seal strength vs. diffusion graphs in Figure 63 and Figure 64. This means that each EDX measurement and seal strength measurement would be taken from the same seal sample of a given seal temperature. The majority of the data collected was collected un-paired. Un-paired meaning that EDX measurements and seal strength measurements were taken from different samples of a given seal temperature. Sample pairing could also work to improve the data correlation with a larger data set.

## CONCLUSIONS

- A technique for tracing ions on the surface of a reactive polymer using EDX was refined. Sodium and oxygen ions were traced.
- A unique “split” seal curve was developed for the dissimilar polymer system used in the study. The reason for the split seal curve can be explained with the DSC results.
- The current ion tracing system did not show a relationship between diffusion distance and temperature at which the seal was made. Likewise, there was no relationship between diffusion distance and seal strength.
- Tracing diffusion via an oxygen is novel. The oxygen based diffusion trace correlated to the sodium based diffusion trace.

## RECOMMENDATIONS FOR FUTURE WORK

Improvements can be made to the materials and methods used in this study. An element with a lower critical ionization energy could be used. Neon, fluorine, oxygen, nitrogen, carbon, boron, beryllium, and lithium have lower critical ionization energies than sodium. However, it is challenging to detect elements lighter than sodium with an x-ray detector with a beryllium window. There are windowless x-ray detectors available, but this would add cost.

The sample could be made conductive by carbon sputtering. If the sample were conductive, higher resolution scanning electron images can be acquired. Charging is eliminated if the sample were conductive, as grounded samples are able to eliminate their excess charge. If the sample were conductive, then a full vacuum could be used. If a full vacuum were used, then wavelength dispersive spectroscopy (WDS) becomes available. WDS offers up to 100 times greater sensitivity than EDX for the analysis of trace elements (Oxford Instruments, 2015).

Another way to make the sample conductive is by compounding with carbon black. Both polymers could be compounded with carbon black in the extruder used to cast the films used in this research.

More time effective and consistent sample preparation techniques could be utilized if the film created for analysis were free from gauge banding. A form of more effective sample preparation would be to utilize a lamination machine to laminate both polymer layers of interest to an inextensible layer. Manually laminating pressure sensitive adhesive tape to the samples was a consistent process, but a machine has the potential to be more consistent. An inextensible layer of choice would be aluminum foil or, an oriented film which behaves in a brittle manner.

If a high precision heat sealer were used, then smaller temperature gradients than 5°F could be used for a more accurate seal curve. If the seal jaws on the heat sealer were wider than 3/8 inches, the seal could be pulled longer for a larger seal curve plateau.

Another polymer system could be used. Ethyl methyl acrylate (EMA) copolymers would react with sodium hydroxide to form a sodium salt. EMA could also potentially be more soluble in low density polyethylene than EMAA.

A polymer system which would be interesting to study is a seal between a zinc ionomer and a sodium ionomer. If both polymers were roughly the same percentage of ionomer, then miscibility should not be an issue. Interesting comparisons could be done with a line scan across a seal interface with two ions, as two relevant diffusion traces could be made. Both sodium and zinc ionomers are commercially available.

With the assistance of a company with free radical polymerization equipment, <sup>13</sup>C or <sup>14</sup>C based polymers could be used. Carbon tagging is a common practice in biology and metabolism studies. <sup>13</sup>C is not radioactive, <sup>14</sup>C is radioactive.

A multistep reaction could be used to tag the surface of the polymer. Such reactions have successfully been done by other researchers (Luo, Stewart, Hirt, Husson, & Schwark, 2004). By using a multistep reaction, something more complex than a positive metal ion could be attached to the reactive sites at the seal interface.

For greater statistical significance, a larger number of samples could be analyzed with EDX via SEM. However, SEM line scan analysis is not a time efficient analysis. The inefficiency limits the practicality of testing too many samples.

## APPENDIX

### Materials and Methods Idea One

DuPont's Nucrel 0403 is a copolymer of polyethylene and methacrylic acid. The methacrylic acid content is 4% by weight. The polymer is produced by a free radical polymerization reaction. The melt index is 3. Dow's 501i low density polyethylene has a melt index of 1.9. 501i LDPE is a barefoot polymer, meaning that it has no additives. LDPE is also produced by a free radical polymerization reaction. These polymers are compatible when heat sealed together. Besides the presence of the acid copolymer in the Nucrel, they are largely similar. When the polymers are sealed, there is a seal interface with properties that vary with sealing temperature. If the reactive groups in the Nucrel are tagged with a fluorescing ion such as europium<sup>3+</sup>, then the amount of diffusion in the seal could possibly be traced with light microscopy. Light microscopy has a resolution of approximately 200nm, a higher resolution than EDX when used to trace sodium ions on a polymer seal. The resolution of light microscopy is higher than EDX in this case because light microscopy is a surface analysis technique. By the nature of the analysis, EDX analyzes a depth profile of the sample. Research has been done where tagging the surface of an acid copolymer was successful (Luo, Stewart, Hirt, Husson, & Schwark, 2004). Research has also been done in the past where monomers were polymerized with fluorescing ions while in solution (Banks, Okamoto, & Ueba, 1980). This led to a fluorescent polymer with chemically bound fluorescing ions. However, when constraints were taken into account, attaching a fluorescent "probe" to the surface of the polymer of interest was not possible. The idea of tagging the seal interface with a fluorescing ion between Nucrel 0403 and 501i LDPE was unsuccessful for several reasons:



- The free radical polymerization of poly (ethylene co-methacrylic acid), PMAA, with a fluorescing rare earth ion requires special equipment.
- Compounding a fluorescent tag into LDPE via mechanical mixing opens up the concern of ion hopping, since the tagging agent would not be chemically bound to the polymer.
- Rare earth salts, the fluorescent compound of choice, do not dissolve well in water. When they do dissociate, they are weakly basic in water. Rare earth salts are also expensive. The rare earth salt used in idea one was europium (III) hydroxide hexahydrate.
- PMAA is not a strong acid, meaning the “acidic H” does not dissociate easily. Weak acids and weak bases form a reaction equilibrium. They do not react to completion.
- Light microscopy has a shallow depth of field (features in different planes are not simultaneously in focus). Cryo-sectioning a seal interface creates a surface which is not level because the surface is repeatedly fractured. It would defeat the purpose of cryo-sectioning to press the seal interface of a sample flat to facilitate analysis in a light microscope.

Analysis with a light microscope would also have benefits:

- Using a fluorescent tag and light microscopy would have benefits. Light microscopy is an economical choice, as light microscopes are less costly to purchase and use than scanning electron microscopes. Rare earth ions have known quantifiable emissions. The analysis of the emissions can be performed using free software. Light microscopy is also

beneficial in that the sample is not subject to a vacuum during analysis. Also, the sample does not need to be conductive for light microscopy analysis.

- Light microscopy could become a feasible route if a multi-step reaction were used to tag the methacrylic acid groups at the surface of the seal interface. Light microscopy could become a feasible technique for this type of research if a neutralized acid copolymer (such as an ionomer) were made with a fluorescing rare earth element.

#### **Materials and Methods Idea Two**

The second idea was to seal a high percentage acid copolymer, Nucrel 1202HC at 11.5% by weight methacrylic acid content, with 501i LDPE. The polymers are compatible in a heat seal. Seals were made, then cross sectioned to expose the seal interface. After the seal was made the available methacrylic acid groups would be reacted with a rare earth salt to induce fluorescence. This technique failed, as apparently the rare earth salt chosen was too weakly basic or weakly dissociating to react with the surface of the PMAA. The same rare earth salt was used for idea one as was used for idea two.

#### **Materials and Methods Idea Three**

The third idea was to seal DuPont's Nucrel 0403 to Dow's 501i LDPE. The reaction would then be traced via a sodium tag. The sodium tag would be provided from sodium hydroxide (NaOH), which is a strong base. Strong bases completely dissociate in water. Seals were made, then cross sectioned to expose the seal interface. The cross sections were then soaked in a 2.5M solution of NaOH for 24 hours. A 2.5M solution of NaOH has a pH of 14.397.

After the seal interface was tagged with sodium ions, it was examined with a scanning electron microscope. When the surface of the "tagged" Nucrel was examined, no sodium ions were found.

It is counterintuitive to think that no reaction occurred. It is likely that a reaction did occur, but the detection limit of the EDX detector used was too low. This could be remedied by using a more sensitive EDX detector, or by using a wavelength dispersive spectroscopy (WDS) detector. WDS detectors are designed for trace element analysis.

The issue could also be remedied by using a sodium neutralized ionomer. However, examining ions which were already present in the sample opens up the possibility of ion hopping. Ion hopping causes unknown inaccuracies in diffusion measurement.

The sample could also be made conductive using carbon sputtering. If the sample were conductive, a higher excitation voltage could be used, which could potentially aid in the detection of the sodium ion.

If the sample were made to be conductive, then a partial atmosphere would not be needed to reduce charging. In a full vacuum, the oxygen portion of the methacrylic acid could be traced. Without a full vacuum, atmospheric oxygen present in the sample chamber poses a source of contamination.

#### **Materials and Methods Idea Four**

A high acid content acid copolymer of unspecified age was used to react with sodium. The polymer used was 1202HC. After the reaction with sodium, the sample was examined via

SEM. The sample showed sodium ions on the surface of the polymer. The seal interface between 501i and 1202HC was clearly visible. However, this system had issues:

- The polymer film had been pre made by an outside source. The polymer had gauge banding that made seal strength analysis challenging.

- The polymer had developed methacrylic acid domains. These were visible in the SEM as spots. If the methacrylic acid had developed domains, then it would be challenging to measure a seal interface as the majority of the sodium ions would be concentrated in the reactive domains rather than spread across the surface of the film.

To remedy the issue of age induced domains, Nucrel 1202HC was cast less than a month before it was used. Samples were cut from the same portion of film to eliminate thickness variations from sample to sample.

### **Final Materials and Methods**

Seals were made between Nucrel 1202HC and 501i LDPE. Both films were cast less than a month before seals were made and SEM analysis was performed. Seals were cross sectioned, and the seal interface was exposed to 2.5M NaOH for 24 hours. After the seals were exposed, SEM analysis was performed with a 50 pascal partial atmosphere. A 50 pascal partial atmosphere was used to prevent the sample from charging. Analysis of the SEM data was done with SAS® and Excel 2013. Tracing of both sodium ions and oxygen ions were successful with this technique. The reaction of the sodium hydroxide with the Nucrel fixed oxygen onto the reactive sites of the Nucrel.

## Material Data Sheets

### DuPont Packaging & Industrial Polymers



#### DuPont™ Nucrel® 1202HC

#### Nucrel® resins Product Data Sheet

##### Description

**Product Description** Nucrel® 1202HC is a copolymer of ethylene and methacrylic acid, made with nominally 11.5 wt% methacrylic acid. It can be processed in conventional extrusion equipment.

##### Restrictions

**Material Status** ● Commercial: Active

##### Typical Characteristics

**Uses** ● Adhesives  
Packaging  
Sealants

**Composition** 11.5 % By Weight Methacrylic Acid comonomer content

##### Typical Properties

Physical	Nominal Values	Test Method(s)	
* Density ( )	0.93 g/cm <sup>3</sup>	ASTM D792	ISO 1183
* Melt Flow Rate (190°C/2.16kg)	1.5 g/10 min	ASTM D1238	ISO 1133
Thermal	Nominal Values	Test Method(s)	
* Melting Point (DSC)	99°C (210°F)	ASTM D3418	ISO 3146
Freezing Point (DSC)	77°C (171°F)	ASTM D3418	ISO 3146
Vicat Softening Point ( )	75°C (167°F)	ASTM D1525	ISO 306

##### Processing Information

**General**

\* Maximum Processing Temperature 310°C (590°F)

**General Processing Information** Nucrel® 1202HC is normally processed at melt temperatures ranging from 160° - 235°C (320° - 455°F) in blown film equipment. A typical extruder profile is below. Actual processing temperatures will usually be determined by either the specific equipment or substrate or one of the other polymers in a coextrusion. Nucrel® 1202HC can also be used in cast extrusions and coextrusions.

Materials of construction used in the processing of this resin should be corrosion resistant. Stainless steels of the types 316, 15-5PH, and 17-4PH are excellent, as is quality chrome or nickel plating, and in particular duplex chrome plating. Type 410 stainless steel is satisfactory, but needs to be tempered at a minimum temperature of 600°C (1112°F) to avoid hydrogen-assisted stress corrosion

Figure 65: Specification Sheet, DuPont 1202HC, Page 1 of 3 (DuPont, 2014)

cracking. Alloy steels such as 4140 are borderline in performance. Carbon steels are not satisfactory. While stainless steels can provide adequate corrosion protection, in some cases severe purging difficulties have been encountered. Nickel plating has been satisfactory, but experiments have shown that chrome surfaces have the least adhesion to acid based polymers. In recent years, the quality of chrome plating has been deteriorating due to environmental pressures, and the corrosion protection has not always been adequate. Chrome over top of stainless steel seems to provide the best combination for corrosion protection and ease of purging.

If surface properties of the extruded resin require modification (such as, lower C.o.F. for packaging machine processing), refer to the Conpol™ Processing Additive Resins product information guide.

After processing Nucrel, purge the material out using a polyethylene resin, preferably with a lower melt flow rate than the Nucrel resin in use. The "Disco Purge Method" is suggested as the preferred purging method, as this method usually results in a more effective purging process. Information on the Disco Purge Method can be obtained via your DuPont Sales Representative.

Never shut down the extrusion system with Nucrel in the extruder and die. Properly purge out the Nucrel with a polyethylene, and shut down the line with polyethylene or polypropylene in the system.

Blown Film Processing	Nominal Values
Blown Film Processing Information	A suggested extruder set temperature profile.
Feed Zone	135°C (275°F)
Second Zone	160°C (320°F)
Third Zone	185°C (365°F)
Fourth Zone	185°C (365°F)
Fifth Zone	185°C (365°F)
Adapter Zone	185°C (365°F)
Die Zone	185°C (365°F)

Cast Film / Sheet Processing	Nominal Values
Cast Film / Sheet Processing	A suggested extruder set temperature profile.
Feed Zone	160°C (320°F)
Second Zone	185°C (365°F)
Third Zone	210°C (410°F)
Fourth Zone	235°C (455°F)
Fifth Zone	235°C (455°F)
Adapter Zone	235°C (455°F)
Die Zone	235°C (455°F)

FDA Status Information	
	<p>NUCREL® 1202HC complies with Food and Drug Administration Regulation 21 CFR 177.1330(a) - - Ionomeric resins, subject to the limitations and requirements therein. This Regulation describes polymers that may be used in contact with food, subject to the finished food-contact article meeting the extractive limitations under the intended conditions of use, as shown in paragraph (c) of the Regulation.</p> <p>The information and certifications provided herein are based on data we believe to be reliable, to the best of our knowledge. The information and certifications apply only to the specific material designated herein as sold by DuPont and do not apply to use in any process or in combination with any other material. They are provided at the request of and without charge to our customers. Accordingly, DuPont cannot guarantee or warrant such certifications or information and assumes no liability for their use.</p>

Figure 66: Specification Sheet, DuPont 1202HC, Page 2 of 3 (DuPont, 2014)

**Regulatory Information**

For information on regulatory compliance outside of the U.S., consult your local DuPont representative.

**Safety & Handling**

For information on appropriate Handling & Storage of this polymeric resin, please refer to the Material Safety Data Sheet.

A Product Safety Bulletin, Material Safety Data Sheet, and/or more detailed information on extrusion processing and/or compounding of this polymeric resin for specific applications are available from your DuPont Packaging and Industrial Polymers representative.

**Read and Understand the Material Safety Data Sheet (MSDS) before using this product**

**Regional Centres**

DuPont operates in more than 70 countries. For help finding a local representative, please contact one of the following regional customer contact centers:

**Americas**

DuPont Company  
Chestnut Run Plaza – Bldg. 730  
974 Centre Road  
Wilmington, Delaware  
19805 U.S.A.  
Toll-Free (USA): 1-800-628-6208  
Telephone: 1-302-774-1000  
Fax: 1-302-355-4013

**Asia Pacific**

DuPont China Holding Co., Ltd.  
Shanghai Branch  
399 Keyuan Road, Bldg. 11  
Zhangjiang Hi-Tech Park  
Pudong New District, Shanghai  
P.R. China (Postcode: 201203)  
Telephone +86 21 3862 2888  
Fax +86-21-3862-2889

**Europe / Middle East / Africa**

DuPont de Nemours Int'l. S.A.  
2,Chemin du Pavillon Box 50  
CH-1218 Le Grand Saconnex  
Geneva, Switzerland  
Telephone +41 22 717 51 11  
Fax +41 22 717 55 00

DuPont do Brasil, S.A.  
Alameda Itapecuru, 506  
06454-080 Barueri, SP Brasil  
Telephone: +55 11 4166 8000  
Fax: +55 11 4166 8736

<http://nucrel.dupont.com>

*The data listed here fall within the normal range of properties, but they should not be used to establish specification limits nor used alone as the basis of design. The DuPont Company assumes no obligations or liability for any advice furnished or for any results obtained with respect to this information. All such advice is given and accepted at the buyer's risk. The disclosure of information herein is not a licence to operate under, or a recommendation to infringe, any patent of DuPont or others. Since DuPont cannot anticipate all variations in actual end-use conditions, DuPont makes no warranties and assumes no liability in connection with any use of this information.*

**CAUTION:** Do not use DuPont materials in medical applications involving implantations in the human body or contact with internal body fluids or tissues unless the material has been provided from DuPont under a written contract that is consistent with DuPont policy regarding medical applications and expressly acknowledges the contemplated use. For further information, please contact your DuPont representative. You may also request a copy of DuPont POLICY Regarding Medical Applications H-50103-3 and DuPont CAUTION Regarding Medical Applications H-50102-3.

Copyright © 2009 DuPont. The DuPont Oval Logo, DuPont™, The miracles of science™, and trademarks designated with ® are registered trademarks or trademarks of E.I. du Pont de Nemours and Company or its affiliates. All rights reserved.

This data sheet is effective as of 08/07/2010 07:54:35 PM and supersedes all previous versions.

Figure 67: Specification Sheet, DuPont 1202HC, Page 3 of 3 (DuPont, 2014)

Technical Information



**DOW™ LDPE 5011**  
Low Density Polyethylene Resin

- Overview**
- A barefoot resin for clarity and bakery film applications
  - Optimum gauge range: 1.0 - 3.0 mil
  - Complies with U.S. FDA 21 CFR 177.1520 (c) 2.1
  - Complies with U.S. FDA - DMF
  - Complies with EU, No 10/2011
  - Complies with Canadian HPFB No Objection (With Limitations)
  - Consult the regulations for complete details.

- Additive**
- Antiblock: No
  - Slip: No
  - Processing Aid: No

Physical	Nominal Value (English)	Nominal Value (SI)	Test Method
Density	0.922 g/cm <sup>3</sup>	0.922 g/cm <sup>3</sup>	ASTM D792
Base Density <sup>1</sup>	0.922 g/cm <sup>3</sup>	0.922 g/cm <sup>3</sup>	Dow Method
Melt Index (190°C/2.16 kg)	1.9 g/10 min	1.9 g/10 min	ASTM D1238
Films	Nominal Value (English)	Nominal Value (SI)	Test Method
Film Thickness - Tested	2.0 mil	51 µm	
Film Puncture Resistance (2.0 mil (51 µm))	51.0 ft-lb/in <sup>2</sup>	4.22 J/cm <sup>2</sup>	Dow Method
Film Toughness			ASTM D882
MD : 2.0 mil (51 µm)	2680 ft-lb/in <sup>2</sup>	221 J/cm <sup>2</sup>	
TD : 2.0 mil (51 µm)	2210 ft-lb/in <sup>2</sup>	183 J/cm <sup>2</sup>	
Tensile Strength			ASTM D882
MD : Yield, 2.0 mil (51 µm)	1760 psi	12.2 MPa	
TD : Yield, 2.0 mil (51 µm)	1710 psi	11.8 MPa	
MD : Break, 2.0 mil (51 µm)	3700 psi	25.5 MPa	
TD : Break, 2.0 mil (51 µm)	2840 psi	19.6 MPa	
Tensile Elongation			ASTM D882
MD : Break, 2.0 mil (51 µm)	650 %	650 %	
TD : Break, 2.0 mil (51 µm)	730 %	730 %	
Dart Drop Impact (2.0 mil (51 µm))	88 g	88 g	ASTM D1709A
Elmendorf Tear Strength			ASTM D1922
MD : 2.0 mil (51 µm)	440 g	440 g	
TD : 2.0 mil (51 µm)	480 g	480 g	
Thermal	Nominal Value (English)	Nominal Value (SI)	Test Method
Vicat Softening Temperature	198 °F	92.2 °C	ASTM D1525
Melting Temperature (DSC)	232 °F	111 °C	Dow Method
Optical	Nominal Value (English)	Nominal Value (SI)	Test Method
Gloss (45°, 2.00 mil (50.8 µm))	76	76	ASTM D2457
Haze (2.00 mil (50.8 µm))	6.7 %	6.7 %	ASTM D1003
Extrusion	Nominal Value (English)	Nominal Value (SI)	
Melt Temperature	422 °F	217 °C	

Figure 68: Specification Sheet, Dow 501i LDPE, Page 1 of 3 (The Dow Chemical Company, 2015)



---

**Extrusion Notes**

---

## Fabrication Conditions For Blown Film:

- Screw Size: 2.5 in. (63.5 mm) 30:1 L/D
- Screw Type: Single Flight Double Mix
- Die Gap: 40 mil (1.02 mm)
- Melt Temperature: 422°F (217°C)
- Output: 10 lb/hr/in. of die circumference
- Die Diameter: 6 in.
- Blow-Up Ratio: 2.5:1
- Screw Speed: 90 rpm
- Frost Line Height: 30 in. (762 mm)

**Notes**

These are typical properties only and are not to be construed as specifications. Users should confirm results by their own tests.

---

<sup>1</sup> Base density is estimated using the assumption that every 1000 ppm of antiblock in the finished product raises the density of the polymer by 0.0006 g/cm<sup>3</sup>. Base density is the estimated density of the polymer if it did not contain any antiblock.

Figure 69: Specification Sheet, Dow 501i LDPE, Page 2 of 3 (The Dow Chemical Company, 2015)

## Product Stewardship

The Dow Chemical Company and its subsidiaries ("Dow") has a fundamental concern for all who make, distribute, and use its products, and for the environment in which we live. This concern is the basis for our Product Stewardship philosophy by which we assess the safety, health, and environmental information on our products and then take appropriate steps to protect employee and public health and our environment. The success of our Product Stewardship program rests with each and every individual involved with Dow products – from the initial concept and research, to manufacture, use, sale, disposal, and recycle of each product.

## Customer Notice

Dow strongly encourages its customers to review both their manufacturing processes and their applications of Dow products from the standpoint of human health and environmental quality to ensure that Dow products are not used in ways for which they are not intended or tested. Dow personnel are available to answer your questions and to provide reasonable technical support. Dow product literature, including safety data sheets, should be consulted prior to use of Dow products. Current safety data sheets are available from Dow.

## Medical Applications Policy

NOTICE REGARDING MEDICAL APPLICATION RESTRICTIONS: Dow will not knowingly sell or sample any product or service ("Product") into any commercial or developmental application that is intended for:

- long-term or permanent contact with internal bodily fluids or tissues. "Long-term" is contact which exceeds 72 continuous hours;
- use in cardiac prosthetic devices regardless of the length of time involved ("cardiac prosthetic devices" include, but are not limited to, pacemaker leads and devices, artificial hearts, heart valves, intra-aortic balloons and control systems, and ventricular bypass-assisted devices);
- use as a critical component in medical devices that support or sustain human life; or
- use specifically by pregnant women or in applications designed specifically to promote or interfere with human reproduction.

Dow requests that customers considering use of Dow products in medical applications notify Dow so that appropriate assessments may be conducted. Dow does not endorse or claim suitability of its products for specific medical applications. It is the responsibility of the medical device or pharmaceutical manufacturer to determine that the Dow product is safe, lawful, and technically suitable for the intended use. **DOW MAKES NO WARRANTIES, EXPRESS OR IMPLIED, CONCERNING THE SUITABILITY OF ANY DOW PRODUCT FOR USE IN MEDICAL APPLICATIONS.**

## Disclaimer

NOTICE: No freedom from infringement of any patent owned by Dow or others is to be inferred. Because use conditions and applicable laws may differ from one location to another and may change with time, the Customer is responsible for determining whether products and the information in this document are appropriate for the Customer's use and for ensuring that the Customer's workplace and disposal practices are in compliance with applicable laws and other governmental enactments. Dow assumes no obligation or liability for the information in this document. **NO WARRANTIES ARE GIVEN; ALL IMPLIED WARRANTIES OF MERCHANTABILITY OR FITNESS FOR A PARTICULAR PURPOSE ARE EXPRESSLY EXCLUDED.**

NOTICE: If products are described as "experimental" or "developmental": (1) product specifications may not be fully determined; (2) analysis of hazards and caution in handling and use are required; (3) there is greater potential for Dow to change specifications and/or discontinue production; and (4) although Dow may from time to time provide samples of such products, Dow is not obligated to supply or otherwise commercialize such products for any use or application whatsoever.

## Additional Information

<b>North America</b>		<b>Europe/Middle East</b>	+800-3694-6367
U.S. & Canada:	1-800-441-4369		+31-11567-2626
	1-989-832-1426	Italy:	+800-783-825
Mexico:	+1-800-441-4369		
<b>Latin America</b>		<b>South Africa</b>	+800-99-5078
Argentina:	+54-11-4319-0100		
Brazil:	+55-11-5188-9000		
Colombia:	+57-1-219-6000	<b>Asia Pacific</b>	+800-7776-7776
Mexico:	+52-55-5201-4700		+603-7965-5392

[www.dowplastics.com](http://www.dowplastics.com)

This document is intended for use within Latin America, North America

Published: 2000-11-30

© 2015 The Dow Chemical Company



Page: 3 of 3

© <sup>TM</sup> Trademark of The Dow Chemical Company ("Dow") or an affiliated company of Dow.

Form No. 400-00007180en  
Rev: 2011-10-05

Figure 70: Specification Sheet, Dow 501i LDPE, Page 3 of 3 (The Dow Chemical Company, 2015)

## SAS® Program

```
data one;
input x y;
infile datalines dlm='09'x;
datalines;

;
/*
proc nlin;
parms c1=20 c2=30 xl=29 xu=32 sd=4;
slope = (c2-c1)/(xu-xl);
int = c1-slope*xl;
model y2 = c1*(x<xl) + (int + slope*x)*(xl <= x <= xu) + c2*(x>xu);
run;
*/
proc means;
/* pick a flat area */
where x lt 23 and x gt 13;
var y;
run;
proc nlmixed;
/* exclude extremes from analysis */
where x gt 15 and x lt 35;

/* c1 is low level of sodium c2 is high xl is end of flat region on low end xu is beginning of flat
region on high end*/
/* change sd based on standard deviation output above from proc means */
arms c1=90 c2=115 xl=24 xu=27.5 sd=9.2;
slope = (c2-c1)/(xu-xl);
int = c1-slope*xl;
mean = c1*(x<xl) + (int + slope*x)*(xl <= x <= xu) + c2*(x>xu);
model y ~ normal(mean,sd*sd);
estimate 'slope' (c2-c1)/(xu-xl);
estimate 'diffusion' (xu-xl);
run;

run;
quit;
```

## WORKS CITED

- about.com. (2015, November). *Diffusion Definition*. Retrieved from Chemistry Glossary and Dictionary: <http://chemistry.about.com/od/chemistryglossary/a/diffusiondef.htm>
- Australian Centre for Microscopy & Microanalysis. (2014, April 15). *SEM*. Retrieved from MyScope Training for Advanced Research: <http://www.ammrf.org.au/myscope/sem/introduction/>
- Australian Microscopy & Microanalysis Research Facility. (2013). *SEM*. Retrieved from MyScope Training for Advanced Research: <http://www.ammrf.org.au/myscope/sem/background/#detail>
- Baer, E., Hiltner, A., Capaccio, G., Nazarenko, S., Stepanov, E. V., & Schuman, T. (1998). Interdiffusion of Linear and Branched Polyethylene in Microlayers Studied via Melting Behavior. *Macromolecules*, 4551-4561.
- Bearden, J. A. (1967, January). X-Ray Wavelengths. *Reviews of Modern Physics*, 39(1), 78-124.
- Benatar, A., & Grewell, D. (2007). Welding of Plastics: fundamentals and New Developments. *Agricultural and Biosystems Engineering*, 43-60.
- Bordeaux, N. (2011, May 25). *Backscattered Electron Emission*. Retrieved from Nanomagnetism Group, Northeastern University: <http://www.northeastern.edu/nanomagnetism/downloads/Backscattered%20Electron%20Emission.ppt.pdf>
- Centre for Imaging and Analysis, U. o. (2015, December). *EDX: LINE SCAN METHODS OF ANALYSIS AND FULL-SCAN ELEMENTAL MAPPING*. Retrieved from ELECTRON MICROSCOPE UNIT: <http://emu.uct.ac.za/training/sem-school/edx-line-scan-methods-of-analysis-and-full-scan-elemental-mapping/>
- Cole, P. J., Cook, R. F., & Macosko, C. W. (2003). Adhesion between Immiscible Polymers Correlated with Interfacial Entanglements. *Macromolecules*, 2808-2815.
- Cole-Parmer. (2015, September 23). *Digi-Sense Dual J-T-E-K Thermocouple Thermometer*. Retrieved from [http://www.coleparmer.com/Product/Digi\\_Sense\\_Dual\\_J\\_T\\_E\\_K\\_Thermocouple\\_Thermometer/EW-91100-40](http://www.coleparmer.com/Product/Digi_Sense_Dual_J_T_E_K_Thermocouple_Thermometer/EW-91100-40)
- Cooper, R. T. (2014). *Microanalysis of Polymer Chain Diffusion in Heat Seals*. Clemson: Clemson University.
- Cryogenics at NASA. (2015, August 19). *Liquid Nitrogen Facts*. Retrieved from <http://education.gsfc.nasa.gov/dln/documents/Cryogenics%20Information.pdf>
- Darby, D. (2015, August 3). *Sealing Technology for Packaging Processes*.

- Dictionary.com,LLC. (2015, November). *depth of field*. Retrieved from Dictionary.com: <http://dictionary.reference.com/browse/depth-of-field>
- dos Santos , W., de Sousa, J., & Gregorio Jr., R. (2013). Thermal conductivity behaviour of polymers around glass. *Polymer Testing*, 987-994.
- DuPont. (2014, September 25). *DuPont Nucrel 1202HC*. Retrieved from DuPont Packaging and Industrial Polymers: [http://www.dupont.com//content/dam/dupont/products-and-services/packaging-materials-and-solutions/packaging-materials-and-solutions-landing/documents/nucrel\\_1202hc.pdf](http://www.dupont.com//content/dam/dupont/products-and-services/packaging-materials-and-solutions/packaging-materials-and-solutions-landing/documents/nucrel_1202hc.pdf)
- Emblem, A., & Emblem, H. (2012). *Packaging technology Fundamentals, materials and processes*. Cambridge: Woodhead Publishing Limited.
- Goldstein, J., Newbury, D., Joy, D., Lyman, C., Echlin, P., Lifshin, E., . . . Michael, J. (2003). *Scanning Electron Microscopy and X-Ray Microanalysis Third Edition*. New York: Springer Science + Business Media New York.
- Grewell, D. A., Benatar, A., & Park, J. B. (2003). *Plastics and Composites Welding Handbook*. Cincinnati: Hanser Gardener Publications, Inc.
- Hafner, B. (2015, August 25). *Energy Dispersive Spectroscopy on the SEM: A Primer*. Retrieved from Characterization Facility, University of Minnesota-Twin Cities: [http://www.charfac.umn.edu/instruments/eds\\_on\\_sem\\_primer.pdf](http://www.charfac.umn.edu/instruments/eds_on_sem_primer.pdf)
- Hurley, A. (2014, January). Packaging Science 3200 Lecture. Clemson, South Carolina.
- Imaging Technology Group, The University of Illinois. (2010). *SEM Basics*. Retrieved from Remote Access Microscopy: [http://virtual.itg.uiuc.edu/training/EM\\_tutorial/](http://virtual.itg.uiuc.edu/training/EM_tutorial/)
- Janalta Interactive Inc. (2015, November). *Adhesive Strength*. Retrieved from corrosionpedia: <https://www.corrosionpedia.com/definition/49/adhesive-strength>
- Kimmel, R. (2015, October 14). Informal Review of Results to Date. (M. Hendrickson, Interviewer)
- Luo, N., Stewart, M. J., Hirt, D. E., Husson, S. M., & Schwark, D. W. (2004). Surface Modification of Ethylene-co-Acrylic Acid Copolymer Films: Addition of Amide Groups by Covalently Bonded Amino Acid Intermediates. *Journal of Applied Polymer Science*, 1688-1694.
- Meka, P., & Stehling, F. C. (1994). Heat Sealing of Semicrystalline Polymer Films. I. Calculation and Measurement of Interfacial Temperatures: Effect of Process Variables on Seal Properties. *Journal of Applied Polymer Science*, 89-103.
- Merriam-Webster, Incorporated. (2015, August). *Dictionary*. Retrieved from Merriam-Webster, An Encyclopedia Britannica Company: <http://www.merriam-webster.com/>

- Najarzadeh, Z. (2014, April). Control and Optimization of Sealing Layer in Films. Montréal, Québec, Canada.
- NORAN Instruments. (1999). *ENERGY-DISPERSIVE X-RAY MICROANALYSIS An Introduction*. Middleton, Wisconsin.
- Oregon, U. o. (2015, August 31). *Electron Beam MicroAnalysis- Theory and Application*. Retrieved from EPMA Lab, UofO Geology 619: [http://epmalab.uoregon.edu/pdfs/Electron%20Beam%20MicroAnalysis-Geol\\_619-3.ppt](http://epmalab.uoregon.edu/pdfs/Electron%20Beam%20MicroAnalysis-Geol_619-3.ppt)
- Oxford Instruments. (2015). *WDS - Wavelength Dispersive Spectroscopy*. Retrieved from Oxford Instruments Products: <http://www.oxford-instruments.com/products/microanalysis/wavelength-dispersive-systems-wds>
- Pry, T., & Armbruster, D. A. (2008). Limit of Blank, Limit of Detection and Limit of Quantification. *The Clinical Biochemist Reviews*, S49-S52.
- Purdue University Chemical Education. (2010). *Size of Atoms*. Retrieved from Ionic Compounds: <http://chemed.chem.purdue.edu/genchem/topicreview/bp/ch7/size.html#metal>
- Qureshi, N. Z., Rogunova, M., Stepanov, E. V., G., C., Hiltner, A., & Baer, E. (2001). Self-Adhesion of Polyethylene in the Melt. 2. Comparison of Heterogeneous and Homogeneous Copolymers. *Macromolecules*, 3007-3017.
- Qureshi, N. Z., Stepanov, E. V., Capaccio, G., Hiltner, A., & Baer, E. (2001). Self-Adhesion of Polyethylene in the Melt. 1. Heterogeneous Copolymers. *Macromolecules*, 1358-1364.
- Register, R. A., & Tierney, N. K. (2002). Ion Hopping in Ethylene-Methacrylic Acid Ionomer Melts As Probed by Rheometry and Cation Diffusion Measurements. *Macromolecules*, 2358-2364.
- Robertson, G. (2013). *Food Packaging: Principles and Practice*. Boca Raton: CRC Press.
- Science Learning Hub, The University of Waikato. (2015, November). *Magnification and Resolution*. Retrieved from Science Learning, Sparking Fresh Thinking: <http://sciencelearn.org.nz/Contexts/Exploring-with-Microscopes/Science-Ideas-and-Concepts/Magnification-and-resolution>
- Selke, S. E., Culter, J. D., & Hernandez, R. J. (2004). *Plastics Packaging Properties, Processing, Applications, and Regulations*. Cincinnati: Hanser Publications.
- Selke, S., Culter, J., & Hernandez, R. (2004). *Plastics Packaging: Properties, Processing, Applications, and Regulations*. Cincinnati: Hanser Publications.
- Si, L., Massa, M. V., Dalnoki-Veress, K., Brown, H. R., & Jones, R. A. (2005). Chain Entanglement in Thin Freestanding Polymer Films. *Physical Review Letters*, 127801-1 - 127801-4.

- Soroka, W. (2009). *Fundamentals of Packaging Technology*. Naperville, IL, U.S.A.: Institute of Packaging Professionals.
- Spring, K., & Davidson, M. (2015, August 25). *The Microscope Optical Train*. Retrieved from MicroscopyU The Source for Microscopy Education:  
<https://www.microscopyu.com/articles/optics/components.html>
- Stehling, F. C., & Meka, P. (1994). Heat Sealing of Semicrystalline Polymer Films. II. Effect of Melting Distribution on Heat-Sealing Behavior of Polyolefins. *Journal of Applied Polymer Science*, 105-119.
- STERIS Isomedix Services. (2015, November). *Ethylene Oxide Sterilization*. Retrieved from Services: <http://www.isomedix.com/services/eo-sterilization/>
- Stoner, J. (2015, August). Informal Extruder Cleaning Guidelines. (M. Hendrickson, Interviewer)
- Study.com. (2015, November). *What is Slope? - Definition & Formulas*. Retrieved from Supplemental Math: Study Aid / Math Courses:  
<http://study.com/academy/lesson/what-is-slope-definition-formulas-quiz.html>
- The Dow Chemical Company. (2015, November 9). *DOW LDPE 501I Low Density Polyethylene Resin*. Retrieved from DOW Low Density Polyethylene (LDPE) Resins:  
<http://catalog.ides.com/docselect.aspx?I=68651&E=7180&DOC=DOWTDS&DS=123&DK=STD&DC=en>
- Theller, H. W. (1989). Heatsealability of Flexible Web Materials in Hot-Bar Sealing Applications. *Journal of Plastic Film and Sheeting*, 66-93.
- University at Buffalo. (2010). *SEM/EDS : Scanning Electron Microscopy*. Retrieved from Faculty Research: <http://wings.buffalo.edu/faculty/research/scic/sem-eds.html>
- Wagner, J. R. (2009). *Multilayer Flexible Packaging: Technology and Applications for the Food, Personal Care, and Over-the-Counter Pharmaceutical Industries*. Burlington, Ma: Elsevier.
- WHO. (2015). *What is Ionizing Radiation*. Retrieved from Ionizing Radiation:  
[http://www.who.int/ionizing\\_radiation/about/what\\_is\\_ir/en/](http://www.who.int/ionizing_radiation/about/what_is_ir/en/)
- Williams, D. B., & Carter, C. B. (1996). *Transmission Electron Microscopy A Textbook for Materials Science*. New York: Springer Science + Business Media New York.
- Woldseth, R. (1973). *All you ever wanted to know about X-ray Energy Spectrometry. First Edition*. Burlingame, CA: Kevex Corp.
- Wolfram Alpha LLC. (2015, August 27). *Area of a Symmetric Lens*. Retrieved from Wolfram Alpha Computational Knowledge Engine:  
<http://www.wolframalpha.com/input/?i=area+of+symmetric+lens>

Wool, R. P., Yuan, B. -L., & McGarel, O. J. (1989). Welding of Polymer Interfaces. *Polymer Engineering & Science*, 1340-1367.