

Clemson University  
**TigerPrints**

---

All Theses

Theses

---

8-2010

# Modeling and Optimization of a Plug-in hybrid electric vehicle

Venkat vijay kishore Turlapati

*Clemson University*, vturlap@g.clemson.edu

Follow this and additional works at: [https://tigerprints.clemson.edu/all\\_theses](https://tigerprints.clemson.edu/all_theses)

 Part of the [Engineering Mechanics Commons](#)

---

## Recommended Citation

Turlapati, Venkat vijay kishore, "Modeling and Optimization of a Plug-in hybrid electric vehicle" (2010). *All Theses*. 917.  
[https://tigerprints.clemson.edu/all\\_theses/917](https://tigerprints.clemson.edu/all_theses/917)

This Thesis is brought to you for free and open access by the Theses at TigerPrints. It has been accepted for inclusion in All Theses by an authorized administrator of TigerPrints. For more information, please contact [kokeefe@clemson.edu](mailto:kokeefe@clemson.edu).

# **MODELING AND OPTIMIZATION OF A PLUG-IN HYBRID ELECTRIC VEHICLE**

---

A Thesis  
Presented to  
the Graduate School of  
Clemson University

---

In Partial Fulfillment  
of the Requirements for the Degree  
Master of Science  
Mechanical Engineering

---

by  
Venkat Vijay Kishore Turlapati  
August 2010

---

Accepted by:  
Dr. Pierluigi Pisu, Committee Chair  
Dr. Ardalan Vahidi  
Dr. John Wagner

---

## ABSTRACT

Today, the world is faced with a situation where new technologies have to be developed to decrease the dependence on natural non-renewable resources. Each day, as the demand for non-renewable resources increases, it puts great pressure on the scientific fraternity to develop new technologies that are aimed at reducing this dependence.

Today's road traffic plays a major part in the energy consumption worldwide. Hence it is imperative that we develop environmentally friendly solutions to this problem that arises in the transportation sector. Hybrid vehicle is one of the alternatives that can be seen as a viable solution to this energy crisis. The recent strides in the field of controls and optimization has led to the evolution of new control and optimization tools to target several simultaneous objectives in a plug-in hybrid electric vehicle.

The control strategies primarily target the minimization of fuel consumption, while meeting the power demand and also enhancing the drivability. The present work deals with the backward and forward modeling of a Power Split Plug-in Hybrid electric Vehicle. The Power-split plug-in hybrid electric vehicle is a combination of both series and parallel hybrid electric vehicles. A power split hybrid derives its name from the power split device namely the planetary gear set. The planetary gear set splits the engine power, allowing for both series and parallel modes. The model developed incorporates the fuel consumption minimization principle viz. Equivalent Consumption Minimization Principle(ECMS).

ECMS principle deals with assigning future fuel costs and savings to the actual usage of electrical energy. Thus, the present usage of electrical energy would mean that this energy has to be balanced by replenishment in terms of future fuel costs and the present usage of fuel for replenishment would be associated with future savings as this energy is available at a lower cost. The ECMS principle used for optimization provided the necessary minimization by maintaining the State of Charge of Renewable Electrical Storage System(RESS) within the prescribed limits. When properly designed by appropriately tuning the charging and discharging coefficients in the minimization strategy, we can optimize the vehicle performance over a given cycle, with the generation of power being intact and perhaps more to conform to the best emission standards in any part of the world.

## DEDICATION

This thesis is dedicated to my parents Dr. Naga Raju Turlapati, Vijaya Lakshmi Turlapati, my sister Sirisha Turlapati.

## ACKNOWLEDGMENTS

I would profusely like to thank my advisor Dr. Pierluigi Pisu for his support and constant help throughout my research and graduate study. I would also like to thank my committee members Dr. Ardalan Vahidi and Dr. John Wagner for the help and advice they have given using their expertise in this field.

I am really thankful for the financial support provided by Clemson University International Center for Automotive research center and the National Science Foundation for this research.

It was a pleasure working with this team and I would like to thank my fellow graduate students for the help through constant discussions. I had a good time working on this research topic in Clemson University

## Contents

Abstract.....	ii
Dedication.....	iv
Acknowledgments.....	v
List of Tables .....	ix
List of Figures .....	x
Chapter One : INTRODUCTION.....	1
1.1 Background and Motivation.....	1
1.2 Classification of Hybrid Electric Vehicle based on Power Source .....	1
1.2.1 Fuel Cell Based Hybrid Vehicle .....	2
1.2.2 ICE Based Hybrid Electric Vehicle .....	2
1.3 Classification of Hybrid Vehicle based on power-train Configuration .....	2
1.3.1 Series Configuration:.....	3
1.3.2 Parallel Configuration: .....	4
1.3.3 Power-Split Configuration:.....	6
1.4 Power Split Device .....	8
1.5 Plug-in Hybrid Electric Vehicle: .....	11
1.6 Contributions.....	12
1.7 Organization of Thesis.....	14
Chapter Two :MODELING APPROACHES IN MODELING OF POWER-TRAINS .....	16
2.1 Backward and Forward Modeling of Power-trains .....	16
2.1.1 Higher level architecture of a backward model .....	16
2.1.2 Higher level architecture of a forward model .....	19
2.1.3 Modeling of Components.....	22

## Chapter Three : POWER MANAGEMENT IN A HYBRID

ELECTRIC VEHICLE .....	34
3.1 Modes of Operation .....	34
3.1.1 Charge Depleting mode: .....	34
3.1.2 Charge Sustaining mode: .....	34
3.1.3 Blended Mode .....	35
3.2 POWER MANAGEMENT STRATEGIES IN A HYBRID VEHICLE .....	36
3.2.1 Rule based strategy.....	36
3.2.2 Dynamic Programming.....	38
3.2.3 Equivalent Consumption Minimization Strategy.....	39
Chapter Four : ECMS AND ITS IMPLEMENTATION .....	43
4.1 Implementation inside the supervisory controller .....	46
4.1.1 Implementation in Charge Depletion mode.....	47
4.1.2 Implementation in charge sustaining mode.....	49
4.2 Differences in Practical implementation between Forward Modeling approach and Backward modeling approach .....	53
4.3 Simulation results .....	54
4.3.1 Fuel economy for UDDS/FUDS cycle and FHDS cycle for Charge Sustaining strategy .....	55
4.3.2 Calculation of fuel consumption in Charge Depletion Mode .....	70
4.4 Differences in Global and Instantaneous fuel minimization approaches .....	77
Chapter Five :CONCLUSIONS AND FUTURE WORK.....	79
Appendices .....	82
Appendix A.....	83
Appendix B.....	85
References.....	87





## LIST OF TABLES

Table 4-1: Fuel consumption results for backward Model.....	56
Table 4-2: Fuel consumption results for Forward Model.....	56
Table 4-3: Fuel economy for Toyota THS configuration using DP( adapted from[14]) .....	57
Table 4-4: Results for Charge depletion mode for UDDS cycle for backward model.....	72
Table 4-5: Fuel economy results for UDDS CD range for backward model.....	73
Table 4-6: Results for Charge depletion mode for UDDS cycle for Forward model.....	73
Table 4-7: Fuel economy results for UDDS CD range for forward model.....	74
Table 4-8: Miles per percent change in SOC for UDDS cycle.....	75
Table 4-9: Results for Charge depletion mode for FHDS cycle for backward model.....	75
Table 4-10: Fuel economy results for FHDS CD range for backward model.....	76
Table 4-11: Results for charge depletion range for forward model .....	76
Table 4-12: Fuel economy for FHDS CD range for forward model.....	77

## LIST OF FIGURES

Figure 1-1: Schematic representation of Series Hybrid electric vehicle .....	3
Figure 1-2: Power Flow diagram in a series hybrid Electric vehicle [3].....	4
Figure 1-4: Parallel hybrid Vehicle with Post-transmission mechanical coupling .....	5
Figure 1-3: Parallel Hybrid with Pre-transmission mechanical coupling .....	5
Figure 1-5: Power Flow in pre-transmission mechanical coupling[3] .....	6
Figure 1-6: Power Flow post-transmission mechanical coupling[3] .....	6
Figure 1-7: Schematic representation of a power-split Hybrid electric vehicle.....	7
Figure 1-8: The Power flow diagram in a power-split hybrid [3].....	7
Figure 1-9: Schematic Diagram of a planetary gear set[16].....	8
Figure 1-10: Schematic layout of power-train of a Power split HEV[by Toyota corporation] .....	9
Figure 2-1: Higher level architecture of a backward Model.....	16
Figure 2-2: Power flow in a backward model.....	17
Figure 2-3: Higher Level architecture of a Forward Model .....	20
Figure 2-4: Power Flow in a Forward Model .....	21
Figure 2-5: Information flow to engine in a backward model.....	23
Figure 2-6: Information flow to engine in a forward model.....	24
Figure 2-7: Information flow to motor/generator in a backward model .....	25
Figure 2-8: Information flow to Motor/generator in a forward model.....	26
Figure 2-9: Information flow to battery.....	27
Figure 2-10: Schematic layout of battery modeling.....	27
Figure 2-11: Schematic layout of Engine Dynamics .....	30
Figure 2-12: Schematic layout of Driver block .....	33
Figure 3-1: Energy path in ECMS for battery discharge[3] .....	41
Figure 3-2: Energy path in ECMS for battery charge[3].....	41
Figure 4-1: Controller Chekcing for SOC limits .....	46

Figure 4-2: Engine On/Off Strategy.....	47
Figure 4-3: Algorithm for power flow in charge depletion mode.....	48
Figure 4-4: Control logic when engine is ON for more than the minimum time for which it can be on before turning off .....	49
Figure 4-5: Control logic when the engine is ON.....	50
Figure 4-6: Control logic when engine speed is less than idle speed.....	51
Figure 4-7: Control Logic when engine speed is more than idle speed .....	52
Figure 4-8: Plot of SOC Vs Time for backward model .....	58
Figure 4-9: Plot of SOC Vs time for Forward model.....	59
Figure 4-10: Velocity profile for backward model .....	60
Figure 4-11: velocity profile for forward model.....	60
Figure 4-12: Optimal Engine Power for backward model .....	61
Figure 4-13: Optimal engine power for forward model .....	61
Figure 4-14: Optimal Engine Speed in Forward model .....	62
Figure 4-15: Optimal Engine speed for backward model.....	63
Figure 4-16: Power curves for Forward model.....	63
Figure 4-17: Power curves for backward model.....	64
Figure 4-18: Optimal Generator Power for backward model(MG1) .....	65
Figure 4-19: Optimal generator Speed for backward model(MG1).....	65
Figure 4-20: Optimal generator speed for forward model(MG1) .....	66
Figure 4-21: Optimal generator power for forward model(MG1) .....	66
Figure 4-21: Operating points of engine over efficiency map for forward model.....	68
Figure 4-22: Operating points over fuel consumption map.....	68
Figure 4-23: Engine Torque associated with best efficiency.....	69

## CHAPTER ONE: INTRODUCTION

### 1.1 Background and Motivation

Environmental concerns and skyrocketing fuel prices have made it necessary to invent new ways that can reduce the impact on natural resources and increase the dependence on non-renewable resources. Recent advancement in the field of automobile science has led to the development of new ways to reduce the dependence on gasoline. Many years of dedicated research has culminated in development of hybrid electric vehicle technology.

A hybrid electric vehicle can be defined as a vehicle that has two or more on-board power sources. The primary power source can be an internal combustion engine or a fuel cell and power sources such as batteries, ultra-capacitors can act as secondary power sources.

Hybrid electric vehicles have the potential to considerably reduce the pollution by reducing the greenhouse gas emissions hybrid electric vehicles reduce the emissions and increase the fuel consumption by regenerative braking (recuperating the vehicle's lost energy during braking)[2] and also allowing the engine to operate at most efficient points.

### 1.2 Classification of hybrid electric vehicle based on power source

Hybrid Electric Vehicles can be classified into two types based on the power source

- Fuel Cell based hybrid electric vehicle
- Internal Combustion based hybrid electric vehicle

### 1.2.1 Fuel cell based hybrid vehicle

A fuel cell hybrid electric vehicle operates mainly on electric power. Fuel cell is a power generating unit which produces power by controlled electrochemical reactions between the oxidant and fuel [8]. Fuel cell based hybrid electric vehicles produce zero emissions.

### 1.2.2 ICE based hybrid electric vehicle

This type of hybrid vehicle uses engine and electric machines to propel the vehicle. The internal combustion engine acts as the main source of energy for the vehicle (except for a Plug-in hybrid electric vehicle where energy is obtained through off-board charging). The motor acts as a secondary power source providing power. Hence both ICE and motor act in conjunction to power the vehicle. ICE is used to charge the battery.

### 1.3 Classification of hybrid vehicle based on power-train configuration

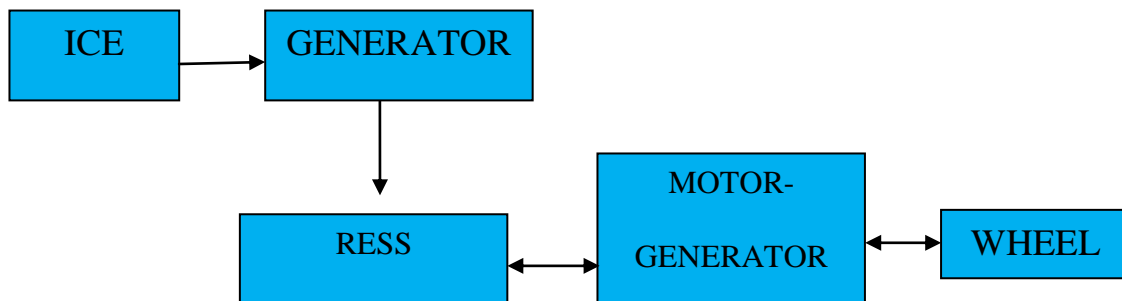
Hybrid electric vehicle can also be classified on the basis of **power-train** architecture. A hybrid electric vehicle is a vehicle that uses two or more power sources to propel the vehicle. Different configurations of hybrid electric vehicles have been developed right from its inception.

The following are the types of HEVs that exist in the market.

- Series Hybrid Electric Vehicle
- Parallel Hybrid Electric Vehicle
- Power-Split Hybrid Electric Vehicle

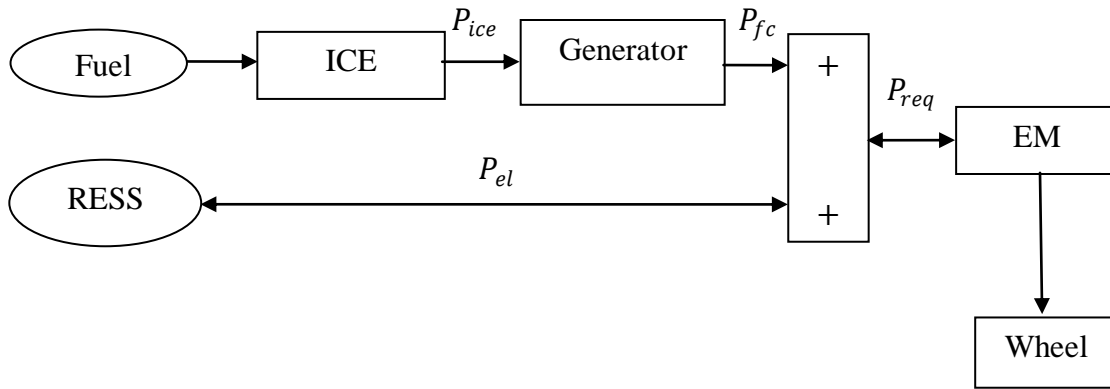
### 1.3.1 Series configuration:

A pure series hybrid electric vehicle decouples the engine from its wheels. It is equivalent to an electric vehicle with a range extender. The advantage a series hybrid electric vehicle has is that the engine can be operated at the most efficient points for best fuel economy. This is possible because of the lack of linkage between the engine and the transmission. The motor powers the vehicle from battery and the engine can be operated independently to charge the battery with the help of generator. The motor acts as a generator during braking. The disadvantage of a series configuration can be the tradeoff in efficiency. In a series configuration, the power always follows electrical path and this has lower efficiency when compared to the mechanical path.



**Figure 1-1: Schematic representation of Series Hybrid electric vehicle**

This series configuration is shown above is further simplified and the following diagram shows the power flow within the series configuration of a hybrid electric vehicle.

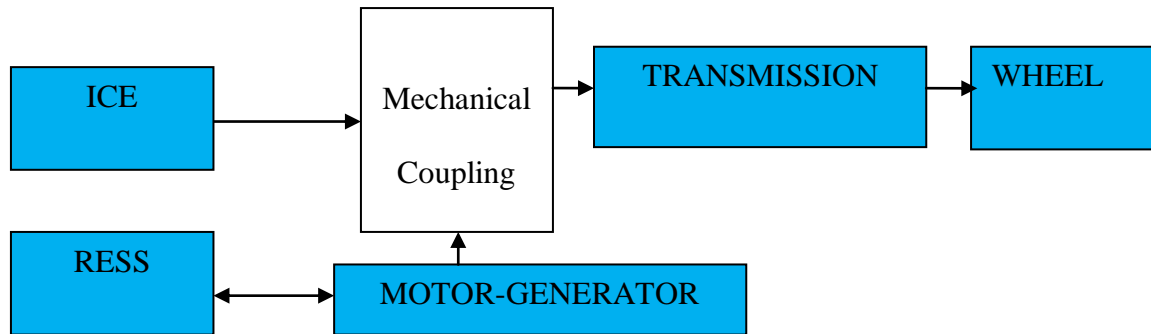


**Figure 1-2: Power Flow diagram in a series hybrid Electric vehicle [3]**

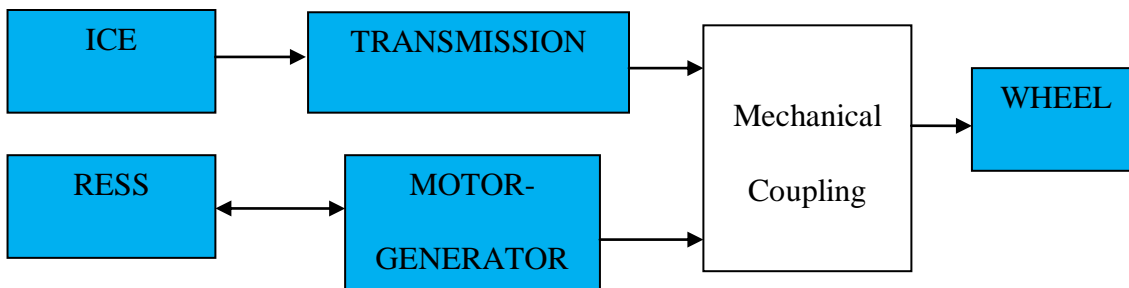
### 1.3.2 Parallel configuration:

A parallel hybrid electric vehicle adds power from the engine to the wheels. The engine and motor are both connected to the wheels directly unlike in a series hybrid electric vehicle. The motor and engine simultaneously drive the vehicle depending on the power split between the two actuators. The motor acts as a generator during braking. The engine is not connected to the generator as it is in the case of a series hybrid electric vehicle. Instead the engine is directly coupled to the transmission. In a parallel hybrid system one can have a pre-transmission and post-transmission electrical coupling. The Figure 1-3 shows the configuration of a pre-transmission mechanical coupling parallel Hybrid vehicle.



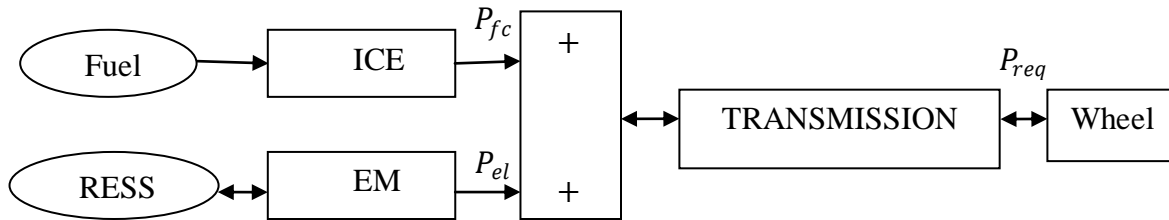


**Figure 1-3: Parallel Hybrid with Pre-transmission mechanical coupling**

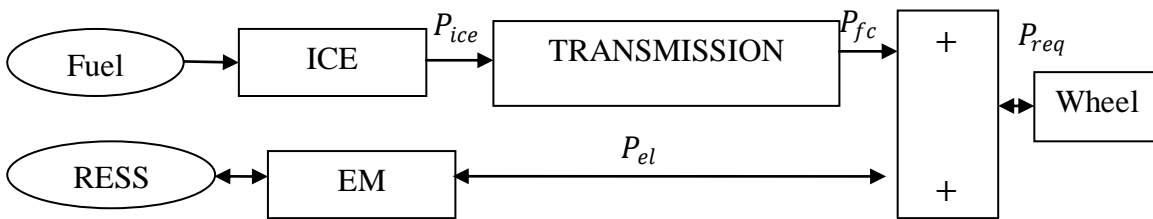


**Figure 1-4: Parallel hybrid Vehicle with Post-transmission mechanical coupling**

The Figure 1-4 shows the schematic diagram of a parallel hybrid vehicle with post transmission mechanical coupling



**Figure 1-5: Power Flow in pre-transmission mechanical coupling[3]**



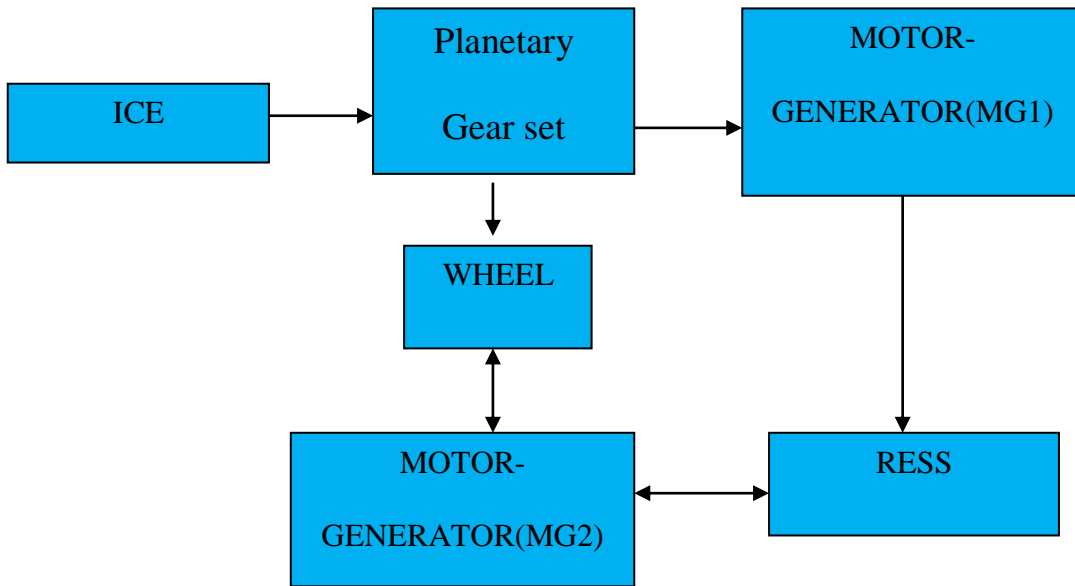
**Figure 1-6: Power Flow post-transmission mechanical coupling[3]**

The Figure 1-5 and Figure 1-6 represent power flow in parallel hybrid electric vehicle with pre-transmission and post-transmission mechanical coupling[3].

### 1.3.3 Power-Split Configuration:

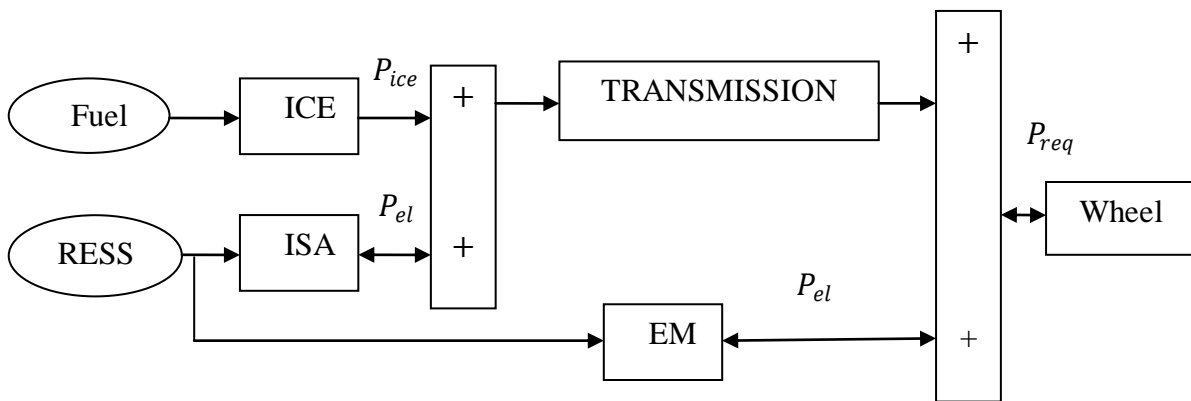
A power split hybrid combines the operation of both Series and parallel configurations. This follows two paths out of which one path is the parallel path and the other series path. The power split in a power split hybrid vehicle is mainly dependent on the power split device ( i.e., the planetary gear set).

The advantage of the power-split configuration lies in the fact that the engine speed can be decoupled from the vehicle speed and hence the engine can be operated at maximum efficiency points[1] This helps in improving fuel economy and reducing emissions.



**Figure 1-7: Schematic representation of a power-split Hybrid electric vehicle**

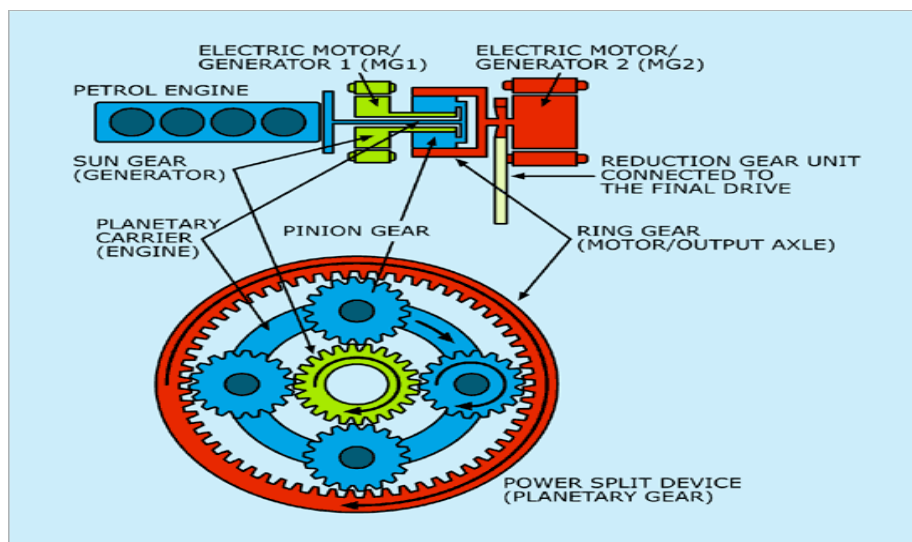
The power flow diagram can be represented as follows



**Figure 1-8: The Power flow diagram in a power-split hybrid [3]**

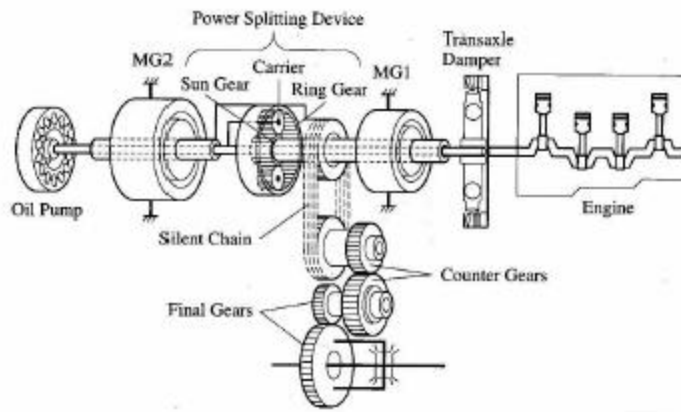
#### 1.4 Power Split Device

The main component of a power split hybrid electric vehicle is the power split device known as Planetary gear set. The dynamics of the power split depend on this planetary gear set. The planetary gear set incorporates a special power transmission system known as Planetary Gear System, or popularly known as Power Split Device (PSD). The Figure 1-9 shows the description of planetary gear system [16]



**Figure 1-9: Schematic Diagram of a planetary gear set[16]**

The gear in the center is known as Sun gear. The gear surrounding the sun gear is known as planet gear. As can be seen from the figure, the planetary gear set has three planets moving on the carrier. The shaft of the planet is connected to the carrier. In a power split hybrid vehicle, the engine (*ICE*) is connected to the carrier, Motor/generator (*MG2*) is connected to the ring gear and Motor/generator (*MG1*) is connected to the sun gear.



**Figure 1-10: Schematic layout of power-train of a Power split HEV[by Toyota corporation]**

The figure above depicts the way in which the two motor/generators and the engine are connected in a Power split device [14]. Motor/Generator (*MG2*) is connected to the ring gear, which in turn is connected to the final transmission. The engine (*ICE*) is connected to the ring gear through planets, and the fraction of torque provided by the engine to the ring gear depends on the number of teeth of each gear. The speed relationship between the constitutive elements of the planetary gear set is shown below.

MG1: Motor/Generator connected to the sun-gear in the planetary gear set predominantly used as generator

MG2: Motor/Generator connected to the ring-gear in the planetary gear set predominantly used as motor.

As a result of mechanical linkage between the components, the speed relationship between the components of planetary gear set can be written as

$$(\omega_{MG1} \cdot S + \omega_{MG2} \cdot R) = \omega_{ice}(R + S) \quad (1.1)$$

Where

S= No of teeth on sun-gear

R=No of teeth on ring gear

Taking the values as per the configuration of Toyota Prius, we have

S= 30 and R=78

Substituting in the above equation we get

$$3.6 \cdot \omega_{ice} - 2.6 \cdot \omega_{MG2} = \omega_{MG1} \quad (1.2)$$

$$\omega_{MG2} = N_f \cdot \omega_{wheel} \quad (1.3)$$

Where

$N_f$  = final transmission ratio

$\omega_{MG2}$  = Angular velocity of MG2

$\omega_{MG1}$  = Angular velocity of MG1

$\omega_{wheel}$  = Angular velocity of wheel

$\omega_{ice}$  = Engine Speed

In a power-split hybrid electric vehicle, the vehicle can function in different modes (Figure 1-8) such as parallel pre-transmission mode (ICE+ISA), parallel post-transmission mode (ICE+EM), series mode (ICE+ISA in regeneration mode and EM in motoring mode) [3]. All these configurations follow the basic power balance equation

$$P_{req}(t) = P_{fc}(t) + P_{el}(t) \quad (1.4)$$

Where

$P_{fc} = \text{Power provided by the fuel converter}$

$P_{el} = \text{Power provided by the electrical accumulator}$

$P_{req} = \text{Power request at the driver}$

In the present research, for a power split hybrid as shown in Figure 1-10 ISA is treated as MG1 connected to the sun gear of the planetary gear set. EM is treated as MG2 connected to the ring gear of the planetary gear set and the speed of the ring gear is same as the speed of the drive axle.

$$P_{el} = P_{el1} + P_{el2} = P_{MG2} - P_{MG1} \quad (1.5)$$

$$P_{MG2} > 0(\text{Motor Mode}), P_{MG2} < 0(\text{generator mode})$$

$$P_{MG1} > 0(\text{Generator mode}), P_{MG1} < 0(\text{Motor mode})$$

### 1.5 Plug-in Hybrid Electric Vehicle:

A plug-in hybrid electric vehicle is different from the normal hybrid electric vehicle. The difference lies in the fact that a plug-in hybrid electric vehicle can use the stored energy during the charge-depleting operation. This use of electrical energy can save considerable amount of fuel. PHEVs use lesser fuel than the conventional HEVs because of the fact that there is a provision for off-board charging of the vehicle. PHEVs enjoy the same benefits as conventional HEVs and also provide an opportunity for switching between fuel and electricity- obtaining some of the energy through a charging plug, which would otherwise be obtained from fuel [20, 21]. Different configurations exist in Plug-in hybrid electric vehicle and these are more or less similar to the Hybrid electric vehicle configuration.

Since the Plug-in hybrid electric vehicle has the facility of off-board charging, the vehicle enjoys the benefits of being operated in a charge depletion mode ( with the engine turned on in the event of high power demand only) until the State of charge of the RESS reaches a particular value. This not only helps in reducing the fuel costs, but also helps in reducing the tailpipe emissions. If the vehicle is operated in charge depleting over the whole trip (with engine not turned on), the vehicle records zero tailpipe emissions.

### 1.6 Contributions

The thesis focuses on design and optimization of a power split plug-in hybrid electric vehicle. The dissertation deals with the implementation of instantaneous fuel consumption strategy viz. ECMS in the backward and forward modeling of a power split plug-in hybrid electric vehicle. The following tasks have been accomplished in the research.

- A backward facing Quasi-static model of the power split plug-in hybrid electric vehicle has been developed and the control strategy has been implemented to minimize the instantaneous fuel consumption of the vehicle.
- A supervisory controller(s-function) is used in the optimization and this the supervisory controller decides the optimal power split between the actuators that minimizes the fuel consumption.



- The vehicle is operated in charge-depleting and charge-sustaining operation and the minimization principle is implemented to maintain the state of charge within a narrow band in the charge sustenance range.
- Similarly a forward facing dynamic model of the power split plug-in hybrid electric vehicle has been developed and the control strategy is implemented to minimize the instantaneous fuel consumption of the vehicle.
- Unlike the backward model, the forward model considers the engine dynamics and it includes a driver and vehicle dynamics block that depicts a real time scenario.
- The driver block decides the current power demand based on the throttle commands generated by the PID controller.
- The forward model includes an engine dynamics block that calculates the engine speed based on the power output from the supervisory controller.
- Each subsystem of the actuator is then given the power output from the supervisory controller as inputs to calculate the efficiencies and real power outputs based on the maps( if in any case they cross the maximum power output).
- The fuel consumption is minimized based on the power output from the supervisory controller and using the minimization principle.
- The fuel consumption is simulated for city and highway cycles and the fuel economy is maximized by tuning the parameters used in ECMS.

## 1.7 Organization of Thesis

The thesis is organized in the following way.

The first chapter deals with providing insight into the concept of Hybrid electric vehicle and goes about with explaining different configurations in hybrid electric vehicles. It also explains about the Plug-in hybrid electric vehicle and power split device which forms the heart of a power-split hybrid electric vehicle.

The second chapter begins by describing backward and forward modeling techniques and its differences. Then it describes the higher level model architecture of both backward and forward models of a plug-in hybrid electric vehicle. The higher level model architecture is then presented along with modeling of individual components.

The third chapter deals with the power management strategies used in the hybrid vehicles and goes about by explaining different power management strategies. It also starts by explaining the local optimization strategy as a local or instantaneous optimization technique used in the research. The basic differences between global optimization and local optimization are explained and it mentions how we can use ECMS in real time applications.

The fourth chapter deals with the implementation of the ECMS strategies in both forward and backward modeling approaches. The equations used to formulate ECMS for both these models have been described. The fourth chapter forms the core of the thesis as it forms the basis for the optimization technique used in the modeling. Both the models have been studied for fuel consumption. This also presents the differences between Global and instantaneous minimization approaches. The fourth chapter presents the

results produced by implementation of fuel consumption strategy and these results are produced for both models for city and highway cycles

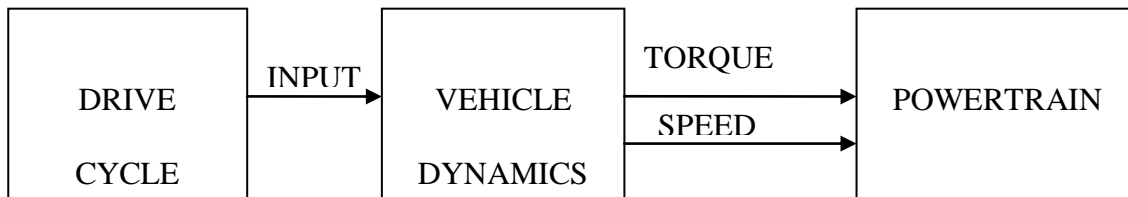
Fifth chapter deals with conclusions and future work that can be done with regard to optimization using ECMS.

## CHAPTER TWO:MODELING APPROACHES IN MODELING OF POWER-TRAINS

### 2.1 BACKWARD AND FORWARD MODELING OF POWER-TRAINS

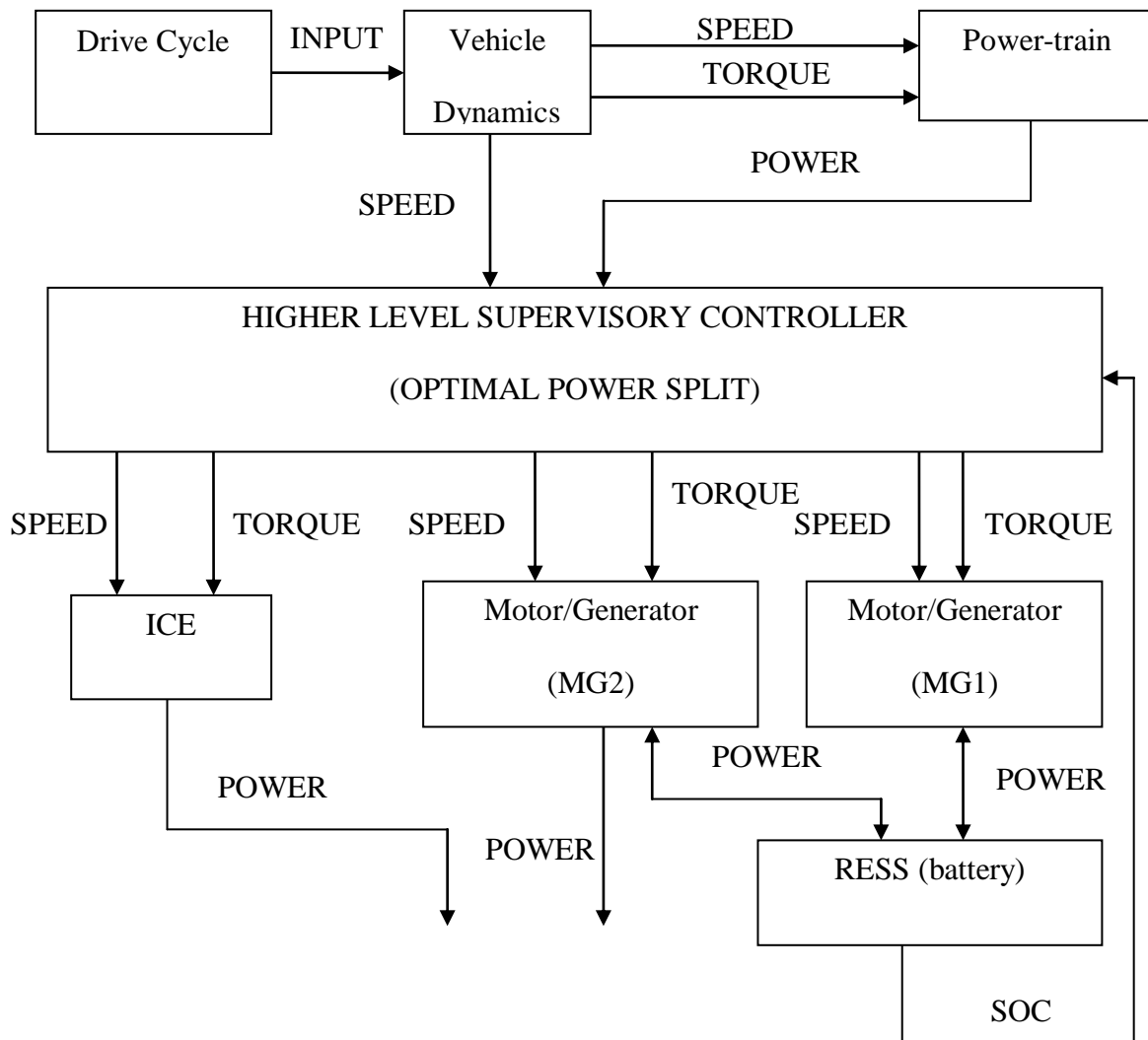
#### 2.1.1 Higher level architecture of a backward model

Any power-train can be modeled in two ways, backward and forward modeling. Backward Model, as the name indicates proceeds backward from the wheels of the vehicle. This is accomplished by having a driving cycle, and it basically assumes that the vehicle follows the velocity prescribed by the drive cycle. The power demand at the wheels is directly calculated from the driving cycle and this power demand is traced back through the power-train to find out the power split between each individual component. The backward model has an inherent assumption that the vehicle always follows the velocity pattern dictated by the driving cycle and hence removes the need of having a driver model. The following flow diagram illustrates the basic power flow in a backward model. The input from the drive cycle to the vehicle dynamics block is usually the force that is computed by comparing the current velocity and the velocity at the next time step derived from the driving cycle.



**Figure 2-1: Higher level architecture of a backward Model**

The Schematic layout of the power flow inside the power-train of a backward model is presented in the following figure. The Figure 2-2 shows the layout for the model used in the present research, i.e. power-split plug-in hybrid electric vehicle.



**Figure 2-2: Power flow in a backward model**

The Power flow in a backward model architecture is shown in the Figure 2-2. The power flow proceeds from the power at the wheels. As mentioned, the backward model does not have a driver block and the power at the wheels is computed from the drive cycle. This power at the wheels is translated into the power request at the higher level supervisory controller (S-function in the present research). The higher level controller computes the optimal power split based on the power demand at the wheels. The controller includes the mathematical equations that are required to simulate the optimal power split in a power-split architecture. The control inputs used in the present research are the

- Power of the motor/generator(MG1 and MG2)
- Power of the engine
- Power of generator

The controller inputs are manipulated to get the optimal power split that minimizes the equivalent fuel consumption as dictated by Equivalent fuel Consumption Strategy which will be discussed in chapters 3 and 4. The higher level uses the current vehicle speed, engine speed and State of charge of the RESS (battery) as the states based on which the controller decides the optimal power split. The basis architecture of backward model neglects faster dynamics and hence the dynamics of components are neglected. The basic power balance equation is modeled in the following way.

$$P_{req}(t) = P_{fc}(t) + P_{el}(t) \quad (2.1)$$

Where

$$P_{req}(t) = \text{Power request at the wheels( from vehicle dynamics)}$$

$P_{fc}(t) = \text{Power from the fuel converter(ICE)}$

$P_{el}(t) = \text{Power of the electric machines}(P_{MG2} - P_{MG1})$

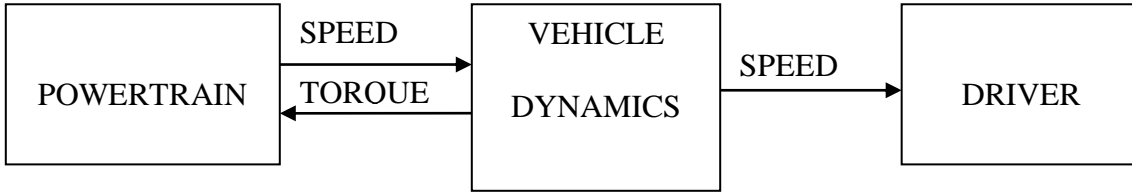
$P_{MG1} = \text{Power of Motor/ generator (MG1)[Mechanical]}$

$P_{MG2} = \text{Power of Motor/ generator (MG2) [Mechanical]}$

We do not include any dynamics in this modeling pattern and hence assume that the power demand from the vehicle dynamics is always met and the controller decides the optimal split based on this power balance equation and the instantaneous fuel minimization principle (ECMS) which will be discussed in chapters 3 and 4.

### 2.1.2 Higher level architecture of a forward model

Forward model on the other hand is a bit more realistic and can be applied to a real time environment. As the name indicates it proceeds forward from the drive train. It includes a driver model which calculates the error in the velocity by tracking the current speed and the speed the velocity has to follow. This error is translated into throttle and brake commands which then calculate the power demand. This power demand is given as an input to the controller to decide the power split between the actuators. This power coming out of the actuators goes through the whole power-train to the wheels. The only difference lies in the fact that the forward model includes a driver block which calculates the power demand unlike in the backward model where it is directly calculated from the drive cycle. The schematic layout of a forward model is presented in the following Figure 2-3.



**Figure 2-3: Higher Level architecture of a Forward Model**

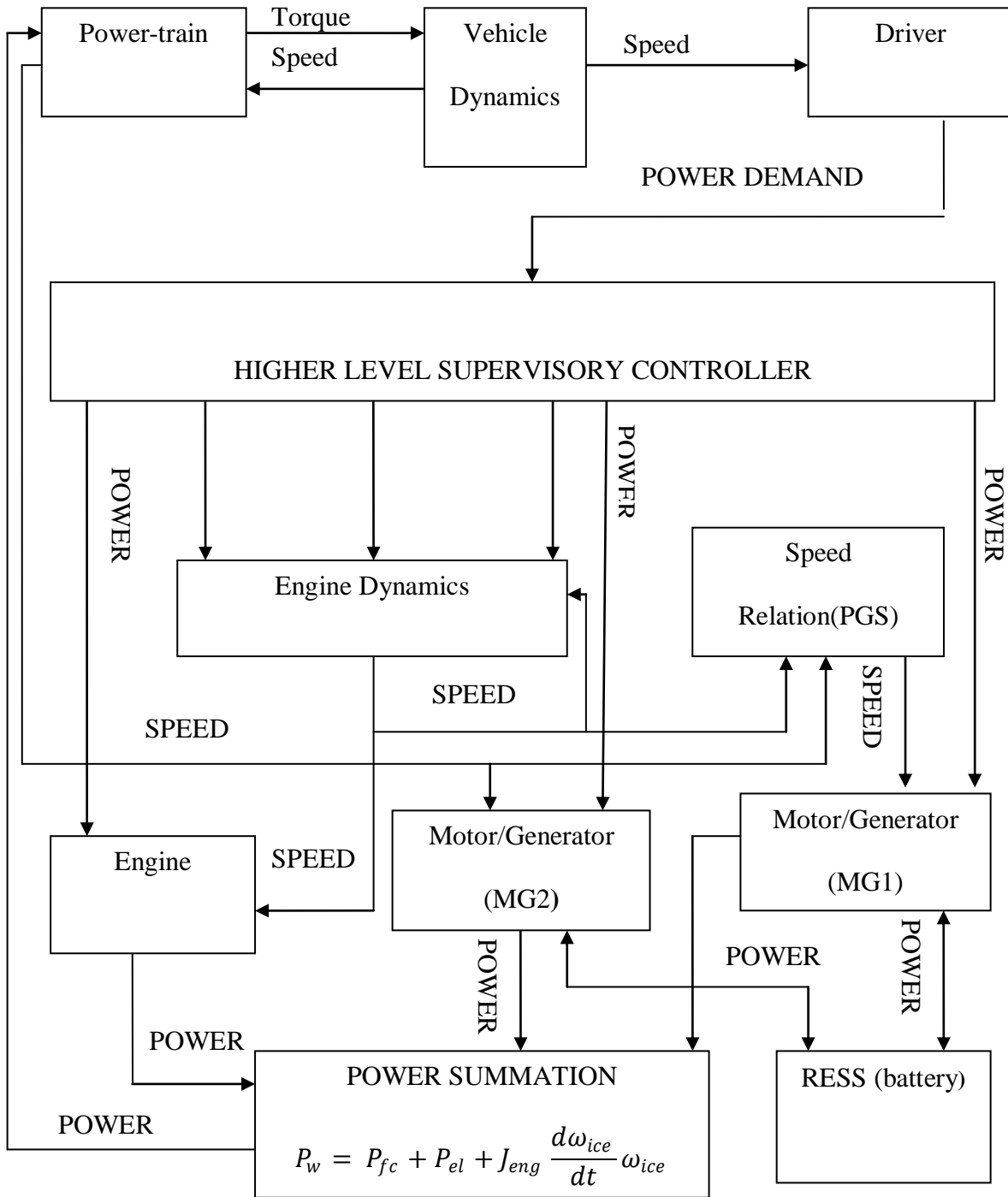
The Schematic layout of the power flow inside the power-train of a forward model is presented in the following Figure 2-4. The following figure shows the layout for the model used in the present research, i.e. power-split plug-in hybrid electric vehicle. Since the forward model includes a driver block which calculates traces the error and computes the power demand.

This power demand goes through the controller and hence to the power-train. Without loss in generality it is assumed that meeting power demand is of highest priority and hence the same power balance equation is used with additional term such as the dynamics of engine. The equation thus becomes

$$P_{req}(t) = P_{fc}(t) + P_{el}(t) + J_{eng}\omega_{eng} \frac{d\omega}{dt} \quad (2.2)$$

The additional term includes the engine dynamics and hence the engine speed is computed as an outcome of power. This equation is used in the forward model to calculate the optimal power split. The figure represents the schematic layout of the power flow inside the power-train and how the power flows from the driver to the power-train through the controller.



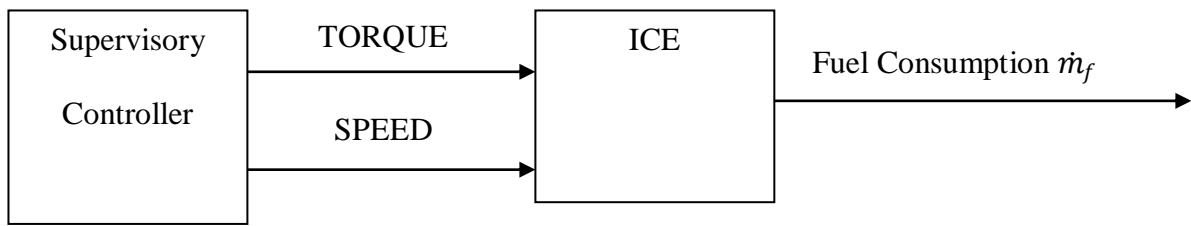


**Figure 2-4: Power Flow in a Forward Model**

### 2.1.3 Modeling of Components

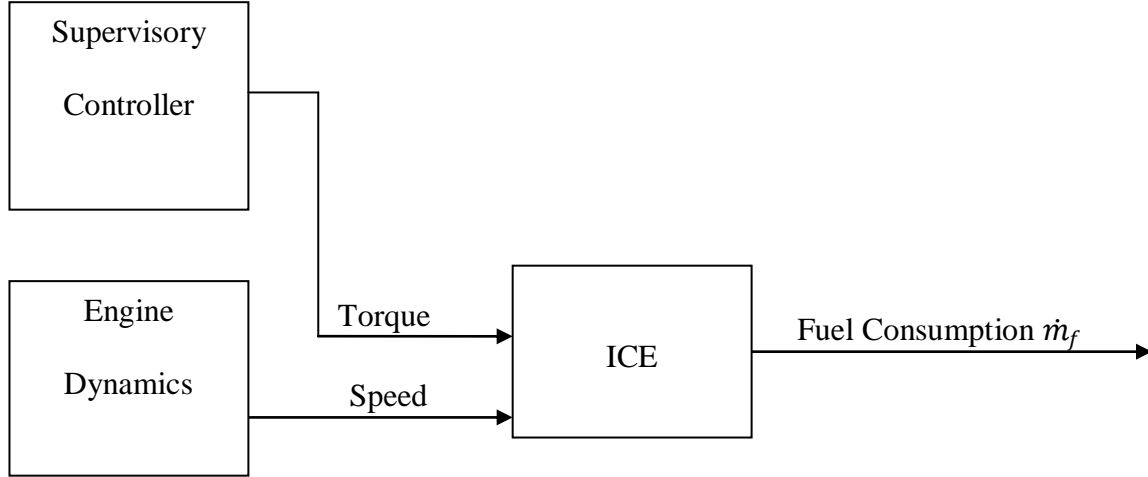
#### 2.1.3.1 Modeling of Engine

The engine is modeled as the following representation. Although the engine fuel consumption, torque and power maps are embedded inside the s-function (supervisory controller), the Figure 2-4 just emphasizes on having them outside to give a deeper insight into the basic backward model architecture. Since the backward model neglects the dynamics of individual components (actuators), it becomes easier just to have a supervisory controller which that calculates the optimal power split that minimizes the fuel consumption. The engine power in the backward model is calculated inside the supervisory controller based on the power request at wheels and also based on the states of the system such as current engine speed, state of charge of SOC and vehicle speed. This optimal engine power is used to calculate optimal fuel consumption based on the fuel consumption maps. The representation of engine modeling inside the Supervisory controller is shown below. Given the power demand (the torque and the optimal speed dictated by the supervisory controller), we can find the fuel consumption of the engine from the specific fuel consumption map. This fuel consumption is the optimal fuel consumption for the optimal power split. This is represented in the Figure 2-5.



**Figure 2-5: Information flow to engine in a backward model**

Though the basic modeling of the engine is same in the forward modeling approach, it becomes imperative to have these subsystems as individual components outside the supervisory controller, replicating a real time environment. Added to this, the forward model, as seen from the perspective of modeling a real time system, it becomes imperative that one has the dynamics included in the model. Hence the supervisory controller in the forward model includes the dynamics in the basic energy or power conservation equation that decides the power split. Since the supervisory controller is triggered each second, the dynamics included here are inherently changing each second and to avoid this we place a real time dynamics block that happen at a faster rate. The basic power balance equation, with the dynamics included, used in the forward model helps us in finding the real engine speed, which along with the torque output from the supervisory controller, is sent to the engine subsystem to calculate the real torque output based on the steady-state engine maps.



**Figure 2-6: Information flow to engine in a forward model**

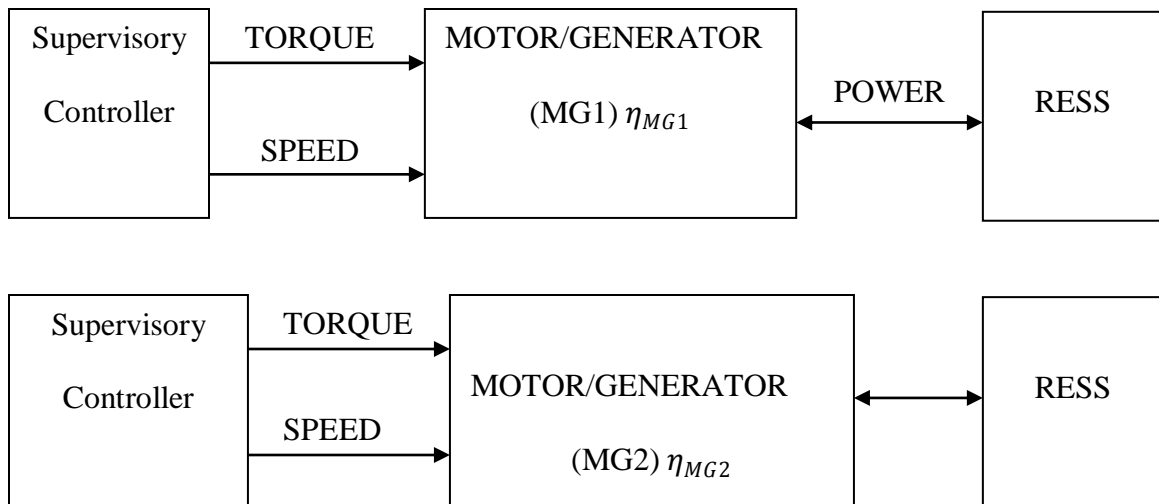
The Figure 2-6 represents the representation of the engine in a forward model

### 2.1.3.2 Modeling of Motor/generator Subsystems

In the configuration used in the research, we have two motor/generators (MG1 and MG2) attached to the power split device (planetary gear set), Figure 1-10. The modeling of these motor/generators is same in both forward and backward modeling approaches.

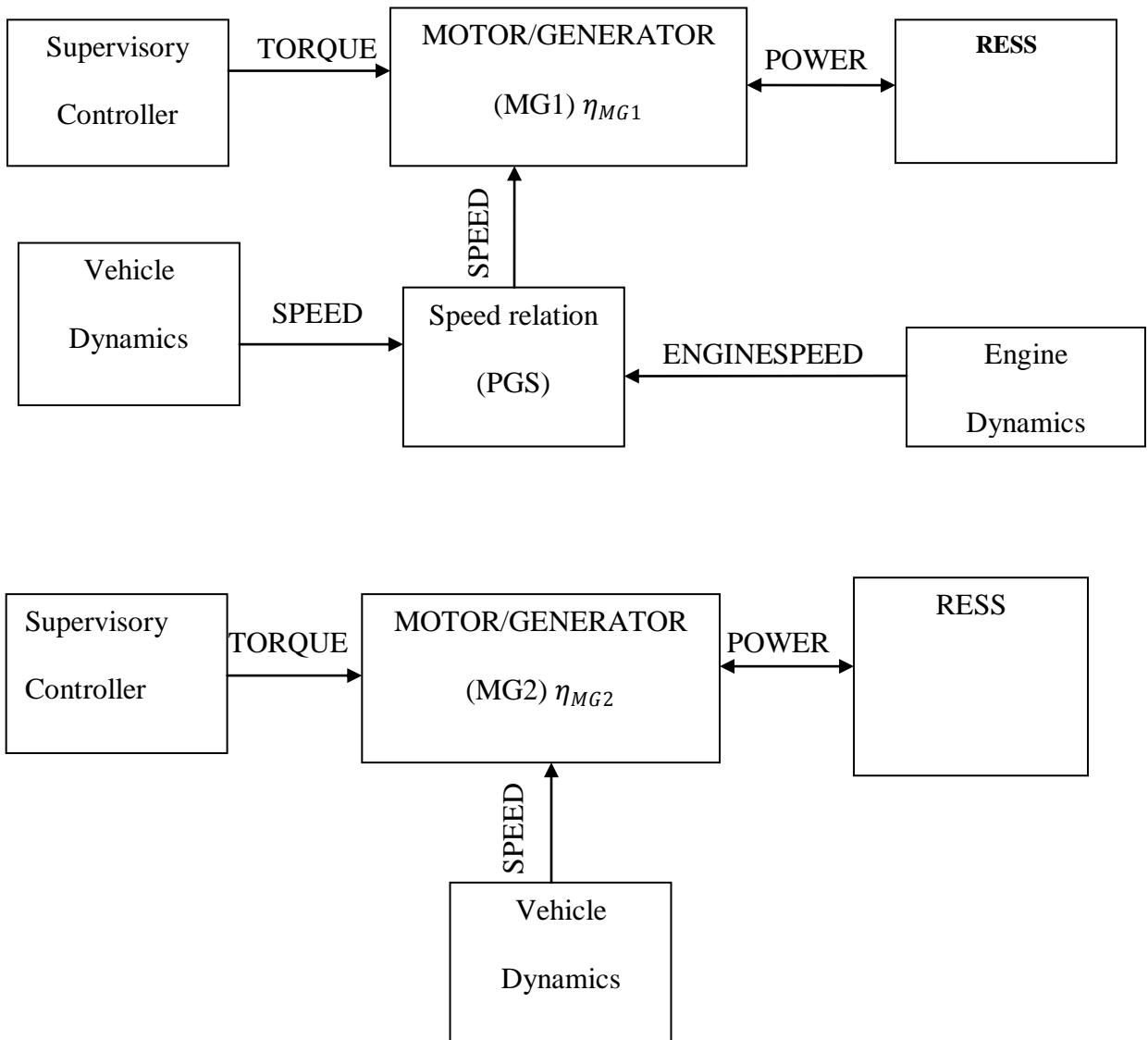
The only difference lies in the fact that the motor and generator sets used in the backward model assume that these sets provide the power dictated by the controller. Although this is true most of the times in the forward model, it becomes necessary to check for the maximum torque or power limitations having the subsystems outside since the forward model depicts a real time system with the dynamics changing at a faster rate than the backward model where the whole system runs at a finite time step. The backward configuration also has them outside the supervisory controller just to calculate

the efficiency losses and hence the power going in/coming out of the Renewable Electrical storage system (RESS or Battery). The representation of each of the Motor/generator sets in backward model is shown in Figure 2-7.



**Figure 2-7: Information flow to motor/generator in a backward model**

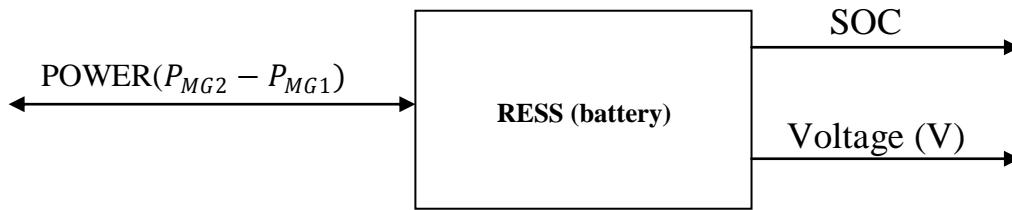
In the forward model, the representation is slightly different. The Figure 2-8 below shows the representation of two motor/generator sets used in the power split configuration.



**Figure 2-8: Information flow to Motor/generator in a forward model**

### 2.1.3.3 Modeling of RESS (battery)

The battery is modeled as a buffer source in the hybrid electric vehicle to store energy during regeneration and also through the engine during charging phase. The basic representation is shown in the Figure 2-9.



**Figure 2-9: Information flow to battery**

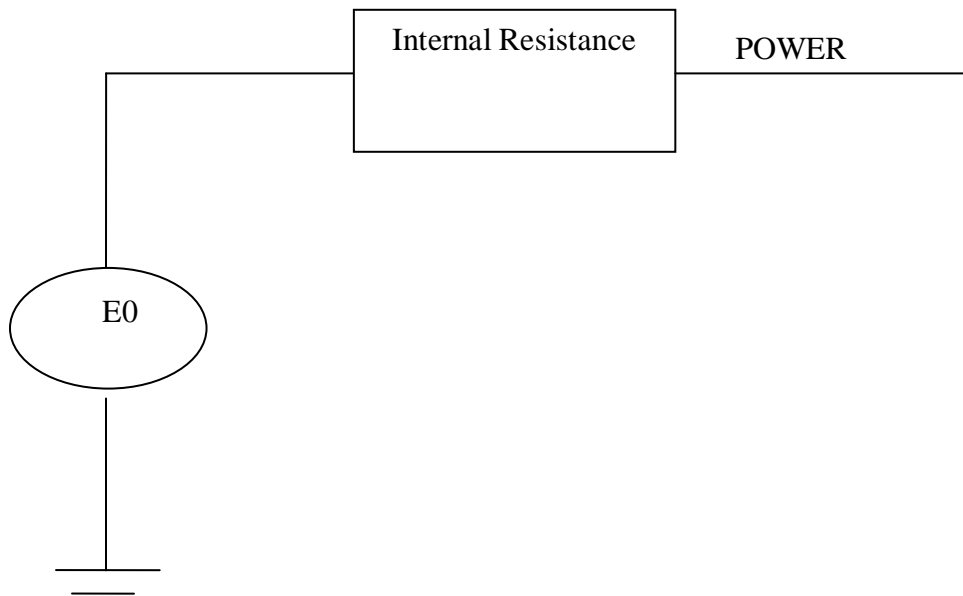
Where

$$P_{MG2} = \text{Power of Motor/generator}(MG2)[\text{Electrical}]$$

$$P_{MG1} = \text{Power of Motor/generator}(MG1)[\text{Electrical}]$$

$$P_{MG2} - P_{MG1} = \text{Power going in or coming out of battery}$$

The battery is modeled as a resistive thermal element. A simple battery model which considers the open circuit voltage and internal resistance is shown below



**Figure 2-10: Schematic layout of battery modeling**

The current is derived from the basic power equation

$$P_{bat} = (E0 - R_i \cdot I) * I \quad (2.3)$$

The solution to this quadratic equation gives the current in terms of Power and open circuit voltage

$$I = \frac{(E0 - \sqrt{(E0^2 - 4R_i P_{bat})})}{(2R_i)} \quad (2.4)$$

Where

*I = battery current*

*R<sub>i</sub> = Internal Resistance of the battery*

*P<sub>bat</sub> = battery Power in W*

*E0 = Open Circuit Voltage of the battery*

The internal resistance ( $R_i$ ) and Open circuit voltage ( $E0$ ) of the battery is inherently a function of State of Charge (SOC) of the battery and temperature of the battery (T). These coefficients are obtained from test data of the real Toyota Prius battery

#### 2.1.3.4 Thermal modeling of batteries

The purpose of thermal management of the battery is to keep the batteries from overheating and hence posing a threat to battery's life. The battery thermal management system sees to it that the battery temperature is under the prescribed limits by turning on the cooling system whenever the temperature of the battery pack rises[23]. The Heat removal process follows natural convection process, where battery loses heat naturally to the surroundings. The fan used in the cooling system turns on when the temperature of the battery pack crosses a particular value and the fan speed increases with the



temperature. The battery controller decides this speed based on the temperature. The temperature of the battery is basically modeled according to the following equation.

$$T_{bat} = \frac{\int_0^t (Q_{in} - Q_{out}) dt}{mC_p} \quad (2.5)$$

It is the integral of the difference between the heat going into the battery and heat exchanged between the battery and ambient air.

Where

$Q_{in}$  = Heat produced due to the current inside the battery(Joule' effect)

$Q_{out}$  = Heat lost due to convection between the battery and surroundings

$$Q_{out} = (T_{bat} - T_{amb}) \frac{\left(1 + \frac{u}{2}\right) (hA)}{mC_p} \quad (2.6)$$

Where

$(hA).N.packs$  = Effective convective heat transfer for the battery

$mC_p.N.packs$  = Thermal Mass of the battery

$N$  = Number of cells in series

$P$  = Number of packs

$hA$  = Average heat transfer over a single cell in the battery pack

$T_{bat}$  = temperature of the battery

$T_{amb}$  = Ambient temperature

$u$  = Fan setting depending upon  $T_{bat}$

When

$$T_{bat} \geq 40, \quad u \text{ is set as } 3$$

$T_{bat} \geq 35$ ,  $u$  is set as 2

$T_{bat} \geq 30$ ,  $u$  is set as 1

*else*

*u is set as zero*

This fan setting helps us to control the battery temperature and hence keep the battery temperature within the prescribed range.

### 2.1.3.5 Modeling of Engine Dynamics

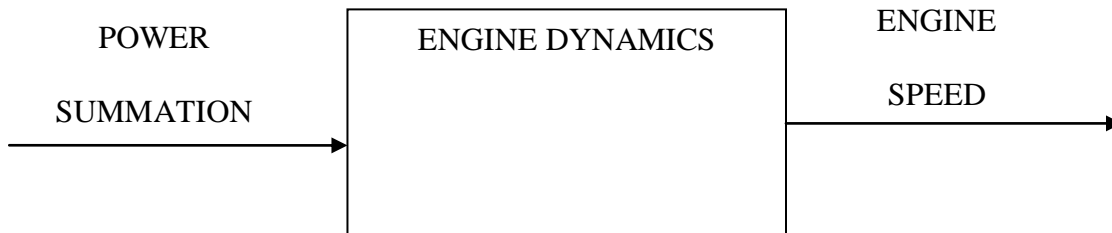
Engine Dynamics is modeled from the energy conservation principle, which generates speed from the power summation provided to it. The formulation used is provided in the equation. The rate of change of kinetic energy is equal to the power.

$$J_{eng} \frac{d\omega}{dt} \omega = \Sigma P \quad (2.7)$$

Where

$J_{eng}$  = inertia of Engine

$\Sigma P$  = Power summation



**Figure 2-11: Schematic layout of Engine Dynamics**

### 2.1.3.6 Modeling of Vehicle Dynamics:

The vehicle dynamics block is modeled according to Newton's Second law of motion which states that the net acceleration produced on the body is always the resultant of the net force acting on the body. The resistive elements acting on the body are the aerodynamic force, drag force and the rolling resistance between the wheel and the ground surface. The following equations describe the vehicle dynamics block

$$m_v \cdot \frac{dv}{dt} = F_{traction} - F_a - F_g - F_r \quad (2.8)$$

$$F_a = \rho_{air} C_d A_f v^2 / 2 \quad (2.9)$$

$$F_g = m_v g \cos(\alpha) \quad (2.10)$$

$$F_r = m_v g C_r \sin(\alpha) \quad (2.11)$$

$$\omega_{wheel} = v / r_{wheel} \quad (2.12)$$

Where

$F_a$  = Aerodynamic force acting on the vehicle in N

$F_g$  = Grade force due to any inclination of the road in N

$F_r$  = Rolling resistance between vehicle and road in N

$C_d$  = Drag Coefficient

$C_r$  = Rolling resistance coefficient

$A_f$  = Vehicle Frontal area in m

$\rho_{air} = \text{Density of air in kg/m}^3$

$\alpha = \text{Inclination of the road surface}$

$m_v = \text{Mass of the vehicle in kg}$

$g = \text{Acceleration due to gravity in m/s}^2$

$v = \text{Vehicle velocity in m/s}$

$F_{traction} = \text{Traction force on the vehicle in N}$

$\omega_{wheel} = \text{Angular velocity of the wheel in rad/s}$

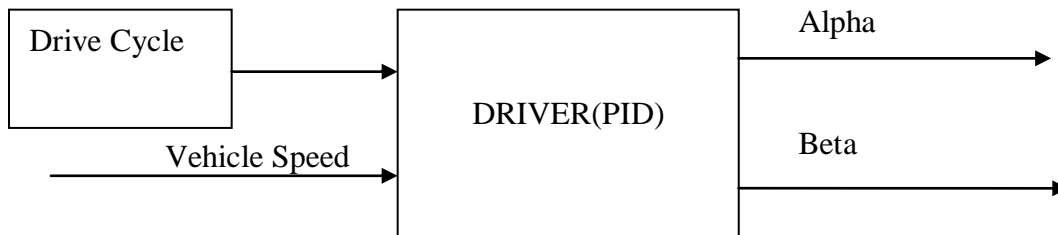
$r_{wheel} = \text{Radius of the wheel in m}$

The traction force creates the basic difference between the forward modeling approach and backward modeling approach. In a backward model it is assumed that the traction force is provided from the vehicle dynamics block assuming that the change in velocity is calculated from the drive cycle. In the forward model the force is the resultant of torque provided by the power-train and hence the acceleration is computed taking into account the force provided by the power-train.

#### *2.1.3.7 Modeling of Driver*

Driver is modeled as a PID controller which takes in the input as vehicle velocity and the driving cycle velocity. It calculates the error based of these two and hence generates a throttle or braking command. These commands are then translated into power request at the actuators. Driver is used only in the forward modeling approach as the need

of driver is avoided in the backward modeling approach by assuming that the power-train always meets the power request calculated from the drive cycle.



**Figure 2-12: Schematic layout of Driver block**

The Figure 2-12 shows the schematic representation of a driver block inside MATLAB/Simulink. This shows the driver as a PID block which takes in error as input and computes the throttle and brake commands as output which later would result in power demand at the actuators, which goes into the supervisory controller for the optimal power split.

## CHAPTER THREE: POWER MANAGEMENT IN A HYBRID ELECTRIC VEHICLE

### 3.1 Modes of Operation

Any plug-in hybrid electric vehicle can be operated in three modes.

- Charge Depleting mode
- Charge Sustaining mode
- Blended mode

#### 3.1.1 Charge Depleting mode:

This mode uses the RESS' power to the maximum extent. The Engine assists the motor only during peak power demand or high acceleration. The battery is depleted until it reaches a particular threshold. The engine assists the vehicle only when the power required is more than the power of the power that the battery can deliver. The battery is only charged in the event of regenerative braking. This mode does not use engine or generator to charge the RESS/battery.

#### 3.1.2 Charge Sustaining mode:

This mode uses both internal combustion engine and RESS simultaneously so that the state of Charge of the Renewable Energy storage device does is maintained within the prescribed limits. The prescribed limit is very small and the control strategy sees to it that the state of charge of the battery does not fall below these limits.

The combined operation in these two modes is known as a CDCS strategy, wherein a vehicle is operated in charge depleting mode initially and when the state of charge of the RESS falls to a particular value, the charge sustaining mode is activated. In charge depleting mode, the engine assists the vehicle during high power demands.

### 3.1.3 Blended Mode

The vehicle can also be operated in **blended** mode during which the engine can be triggered more often when compared to the charge depletion operation. This ensures that the vehicle takes longer time to reach charge sustaining operation.

One advantage that blended operation has when compared to CDCS strategy is that the by delaying the charge sustenance phase the overall PHEV costs are reduced.

In the charge depleting phase (in plug-in hybrid electric vehicles), the freedom of operating the engine at higher efficiencies is constrained. Normally a power-split architecture enjoys the benefits of decoupling the engine and allowing it to run at points where fuel efficiency is maximum[1], but in charge depleting mode the engine power is requested only when the power demand cannot be met by the electric machines. Hence this reduces the freedom of operating the engine at maximum fuel efficient points. In blended strategy this can be achieved by running the engine more often even if the power demand can be met by the electric machines alone. This allows for operating the engine at high efficiency points. This allows for utilization of electric energy over a longer range in charge depletion mode and hence improving the fuel economy[1].

### 3.2 POWER MANAGEMENT STRATEGIES IN A HYBRID VEHICLE

Hybrid vehicles constitute at least two different power sources. A hybrid power-train combines the operation of two or more modes of propulsion to achieve better results when compared to a normal single power-train. This kind of configuration can produce better results in terms of reduction of fuel consumption and improving fuel economy. The performance of Hybrid electric vehicle strongly depends on the power split. And this power split plays a major role in the minimization of fuel consumption. When two or more power sources are available, the control strategy has to determine optimal power distribution between the two sources that minimize the fuel economy. The power split is constrained by two factors: The driver power demand must be met and the State of Charge of the RESS must be maintained within the prescribed limits. Within these constraints the motive power must be split to minimize the fuel consumption. Different Power management strategies have been developed in different configurations of hybrid electric vehicles.

- Rule based techniques
- Dynamic Programming
- Local Optimization(Equivalent Consumption Minimization strategy)

#### 3.2.1 Rule based strategy

The first technique is the **Rule based** technique. This control technique is implemented using heuristic control knowledge to develop a set of event triggered rules. The decision to operate different actuators depends on a set of parameters like State of Charge of RESS, power demand from the vehicle, current speed of the internal



combustion engine. The rule based control strategy can be designed in such a way that either of the two actuators i.e. ICE or Motor can act as the main propelling device[ Normally in PHEVs, the motor acts as the main propelling unit, with engine charging the batteries and assisting the vehicle during high power demand. The other actuator is activated depending on a set of event triggered rules. This device is generally termed as a load-leveling device. The engine can also act as the main propelling source with the RESS acting as a load leveling device [14]. In the present description of the rule based strategy for a power split plug-in hybrid electric vehicle [11,12,20], we consider Motor attached to the ring gear as the main propelling device and engine as the secondary device assisting the motor. The motor is always driving the vehicle, and the decision to turn on or turn off the engine depends on a set of parameters like State of Charge of battery, power demand from the vehicle. We can categorize different modes of operation as

- Start: Depending on the power demand during vehicle start, the power can be split between motor and engine based on certain set of event triggered rules.
- Stop: During this phase the vehicle comes to a complete halt and the engine can be made to run at idle speed or can simply be turned off.
- Cruise mode: Normal driving mode without any high acceleration. The power demand is satisfied by the motor alone if the State of Charge is within the limits ( in charge depletion mode).
- Hard Acceleration: The engine provides the additional torque to meet the torque/power demand.

- Recharge: When state of charge of the RESS falls below a particular threshold, engine helps in charging the RESS through generator.
- Regeneration: The regenerative braking helps in recuperating kinetic energy.
- Hard braking: During this phase, conventional braking is activated to stop the vehicle.

### 3.2.2 Dynamic Programming

The second technique is based on Global optimization that is usually presented in the form of Dynamic Programming. Although rule based strategies helped researchers in the budding stages of hybrid vehicle research, these strategies were not useful in minimizing the overall fuel consumption of a hybrid electric vehicle. This necessitated further research into the strategies that minimize the overall global fuel consumption by satisfying various physical constraints imposed on the power-train.

Dynamic programming can be referred to as a global optimization strategy. Dynamic Programming (DP) is a multistage decision making process requiring a sequence of interrelated decisions [9,10]. Dynamic programming is a recursive approach. It simplifies by breaking the problem into a set of smaller problems and by combining them using a recursive approach. For a given system the dynamic programming approach follows a search algorithm that searches all values of control inputs over state that has been discretized. Normally in global optimization problem for minimization of fuel consumption the cost function is the total fuel consumption. Dynamic programming approach combines different objectives such as minimizing the fuel consumption and keeping the battery State of Charge sustained. One such constraint is known as hard

constraint where final state of charge is equal to the initial state of charge. One can also use a soft constraint by adding a penalty term that accounts for the deviation of the final SOC from initial SOC. When a soft constraint is used the global optimization problem reduces to the following equation [17]

$$\min_{\{P_{fc}(t), P_{el}(t)\}} \left( \int_0^T \dot{m}_f(\tau) d\tau + \varphi(SOC_i, SOC_f) \right) \quad (3.1)$$

When a hard constraint is used the resultant energy of the battery becomes zero and the cost function reduces to the following equation.

$$\min_{\{P_{fc}(t), P_{el}(t)\}} \int_0^T \dot{m}_f(\tau) d\tau \quad (3.2)$$

Hence a comparison can be made with a conventional vehicle.

*Note:  $P_{fc}(t)$  is the power of the fuel converter and  $P_{el}(t)$  is the power of the electric machines.  $P_{el}$ , in the present work is, i.e. the power split hybrid, is the combined power of the two motor/generators.*

$$P_{el} = P_{MG2} - P_{MG1} \quad (3.3)$$

- *MG1: Motor/Generator connected to the sun-gear in the planetary gear set predominantly used as generator*
- *MG2: Motor/Generator connected to the ring-gear in the planetary gear set predominantly used as motor.*

### 3.2.3 Equivalent Consumption Minimization Strategy

Ideally the motive power split must be split at each time to minimize the overall fuel consumption over a given trip as [3,9,10]

$$\min_{\{P_{fc}(t), P_{el}(t)\}} \int_0^T \dot{m}_f(\tau) d\tau \quad (3.4)$$

$$P_{req}(t) = P_{fc}(t) + P_{el}(t)$$

$$0 < SOC_{min} \leq SOC \leq SOC_{max} \leq 1$$

$$0 \leq P_{fc}(t) \leq P_{fc,max}$$

The main issue with this approach is that the driving cycle has to be known a priori, hence it becomes difficult to derive real time control strategy to such type of problems. One can avoid this issue by replacing the global criterion by a local one. Thus the global problem of minimizing the fuel consumption is reduced to an instantaneous minimization problem. The local criterion becomes[4,5,6,7]

$$\min_{\{P_{fc}(t), P_{el}(t)\}} \dot{m}_{f,eq}(t) \quad \forall t$$

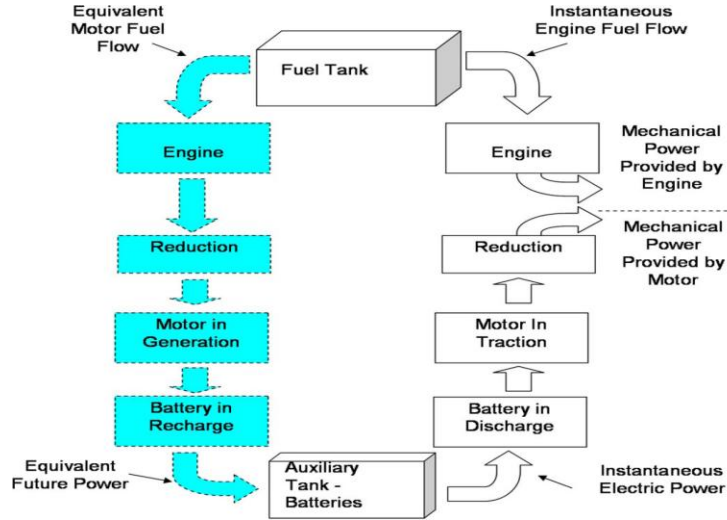
The global fuel consumption minimization can thus be replaced by

$$\int_0^{T_f} \min_{\{P_{fc}(t), P_{el}(t)\}} \dot{m}_{f,eq}(t) d\tau \quad (3.5)$$

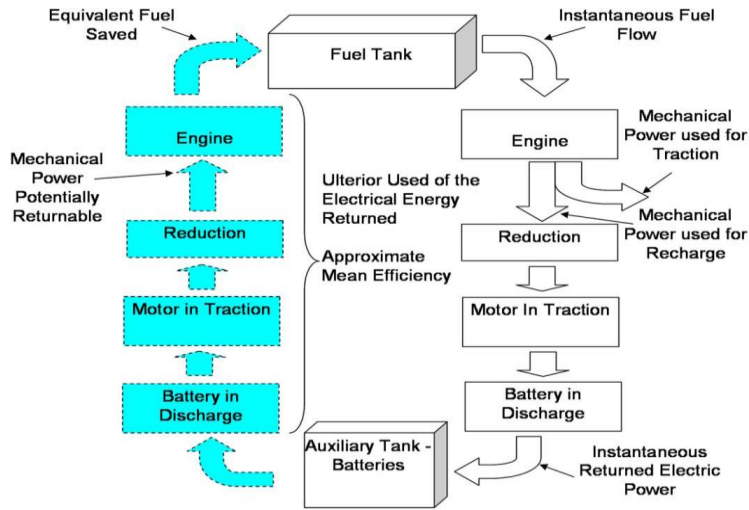
In a charge sustaining hybrid any present discharge or charge of the battery must be balanced by a future charge or discharge respectively. The main idea behind ECMS mainly consists of assigning future fuel costs and savings to the actual use of electrical energy.

- A present discharge of the RESS corresponds to a future fuel consumption that will be necessary to recharge the RESS.
- A present charge of the RESS corresponds to a future fuel savings since this energy is available in the future at a lower cost.

The energy flow diagram in ECMS is represented in Figure 3-1: Energy path in ECMS for battery discharge & Figure 3-2



**Figure 3-1: Energy path in ECMS for battery discharge[3]**



**Figure 3-2: Energy path in ECMS for battery charge[3]**

The equivalent fuel consumption is generally defined as

$$\dot{m}_{f,eq} = \dot{m}_{f,ICE}(\omega_{ice}, P_{ice}) + \dot{m}_{f,RESS,eq}(P_{RESS}) \quad (3.6)$$

Where

$\omega_{ice}$  or  $\omega_{eng}$  (in the present research) = Engine Speed

$P_{ice}$  = Power provided by engine

And ( $P_{RESS}$ ) is the power from the Renewable electrical Storage system (battery).

The total equivalent fuel consumption is thus the summation of fuel flow rate of internal combustion engine and the equivalent fuel flow rate of Renewable electrical Storage system (RESS). In order to maintain the life of the battery, we constrain the battery to operate within prescribed SOC limits. In order to do this, a weighting factor  $f(SOC)$  was introduced by Paganali et al. (2002). The  $f(SOC)$  regulates the SOC within the prescribed limits. Thus the formulation of equivalent fuel consumption becomes

$$\dot{m}_{f,eq} = \dot{m}_{f,ICE}(\omega_{ice}, P_{ice}) + f(SOC) \cdot \dot{m}_{f,RESS,eq}(P_{RESS}) \quad (3.7)$$

$f(SOC)$  is generally a penalty function which penalizes the deviation of SOC from the prescribed limits.

Where

$\dot{m}_{f,eq}$  = Equivalent fuel flow rate

$\dot{m}_{f,ICE}(\omega_{ice}, P_{ice})$  = Fuel flow rate of engine

$\dot{m}_{f,RESS,eq}(P_{RESS})$  = equivalent fuel cost or savings  
associated with battery

## CHAPTER FOUR: ECMS AND ITS IMPLEMENTATION

Formulation of equations in ECMS for a power split hybrid

In a power split hybrid  $P_{el}$  can be divided into three cases

$$P_{RESS} = \frac{P_{MG2}}{\eta_{PE} \cdot \eta_{b,dis} \cdot \eta_{MG2}} - (P_{MG1} \cdot \eta_{PE} \cdot \eta_{b,chg} \cdot \eta_{MG1}) \quad (4.1)$$

$P_{MG1} > 0$  (Generator mode) and  $P_{MG2} > 0$  (Motor mode)

$$P_{RESS} = \frac{P_{MG2}}{\eta_{PE} \cdot \eta_{b,dis} \cdot \eta_{MG2}} - \frac{P_{MG1}}{\eta_{PE} \cdot \eta_{b,dis} \cdot \eta_{MG1}} \quad (4.2)$$

$P_{MG1} \leq 0$  (Motor mode) and  $P_{MG2} \geq 0$  (Motor mode)

$$P_{RESS} = P_{MG2} \cdot \eta_{PE} \cdot \eta_{b,chg} \cdot \eta_{MG2} - P_{MG1} \cdot \eta_{PE} \cdot \eta_{b,chg} \cdot \eta_{MG1} \quad (4.3)$$

$P_{MG2} \leq 0$  (Generator mode)       $P_{MG1} \geq 0$  (Generator mode)

From the Basic equation of Instantaneous fuel consumption minimization one can write the fuel minimization equation for a power split hybrid in the following way [3].

$$\dot{m}_{f,RESS,eq}(P_{RESS}) =$$

$$\begin{aligned} & \left( \frac{1}{Q_{lhv}} \right) \cdot (S_{chg} \cdot \left( \frac{(P_{MG2}/\eta_{MG2}) - (P_{MG1}/\eta_{MG1})}{\eta_{PE} \cdot \eta_{b,dis}} \right) \cdot \gamma_1 \\ & + S_{dis} \cdot (P_{MG2} \cdot \eta_{MG2} - P_{MG1} \cdot \eta_{MG1}) * \eta_{PE} \cdot \eta_{b,chg} \cdot (1 - \gamma_1) \cdot \gamma_2 \\ & + (S_{chg} \cdot \gamma_3 \cdot (1 + \text{sign}(\gamma_3)))/2 + S_{dis} \cdot \gamma_3 \cdot (1 - \text{sign}(\gamma_3))/2) \cdot (1 \\ & - \gamma_2) \end{aligned} \quad (4.4)$$

$$\gamma_1 = \frac{1 + \text{sign}(P_{MG2})}{2}$$

$$\gamma_2 = \frac{1 - \text{sign}(P_{MG2} \cdot P_{MG1})}{2}$$

$$\gamma_3 = \frac{P_{MG2}}{\eta_{PE} \cdot \eta_{b,dis} \cdot \eta_{MG2}} - P_{MG1} \cdot \eta_{PE} \cdot \eta_{b,chg} \cdot \eta_{MG1}$$

Where

$P_{MG2} = \text{Power of (MG2)[Mechanical]}$

$P_{MG1} = \text{Power of (MG1)[Mechanical]}$

$P_{RESS} = \text{Power of RESS(battery)[Electrical]}$

$\eta_{PE} = \text{Efficiency of Power Electronics}$

$\eta_{b,dis} = \text{Efficiency of battery during discharge}$

$\eta_{b,chg} = \text{Efficiency of battery during charge}$

$Q_{lhv} = \text{Lower Heating value of fuel}$

$S_{chg} = 1/\eta_{chg}, S_{dis} = \eta_{dis}$

$\eta_{chg} = \text{Average efficiency in all charging conditions}$

$\eta_{dis} = \text{Average efficiency in all discharging conditions}$

The charge and discharge coefficients,  $S_{chg}$  and  $S_{dis}$ , in practical situations are considered as unknown parameters to be tuned. Although Dynamic Programming requires you to know the whole driving cycle a priori, the validity of ECMS algorithm depends on the tuning of parameters ( $S_{chg}, S_{dis}$ ). The parameters are very sensitive and right tuning of these parameters would help one realize a charge sustaining behavior

In particular, using the battery to supply the power demand lowers the fuel consumption, but an additional amount of energy is needed in future to recharge the battery and similarly using engine to charge the battery increases the instantaneous fuel consumption but this reduces the fuel consumption in future since the energy is saved for future use. Hence the equivalent fuel consumption is regarded as the sum of



instantaneous fuel consumption of both engine and battery. The Control strategy has to minimize the fuel consumption and at the same time meet the driver power request. To meet the power request the controller has to know the power request and decide between the power split between the various actuators that minimizes the instantaneous fuel consumption. ECMS control strategy can be applied in real time unlike dynamic programming which is computationally extensive and at the same time requires the driving cycle be known a priori. In the present research, the implementation of ECMS strategy in both forward and backward models is the same except for the dynamics involved in the forward model.

In this section we will go step by step through the higher level supervisory controller and how the controller responds to the control signals and how it optimizes the fuel consumption. The model dynamics are modeled in MATLAB/Simulink and an embedded s-function is called each time to calculate the optimal fuel consumption of the model. A plug-in hybrid electric vehicle operates in two modes.

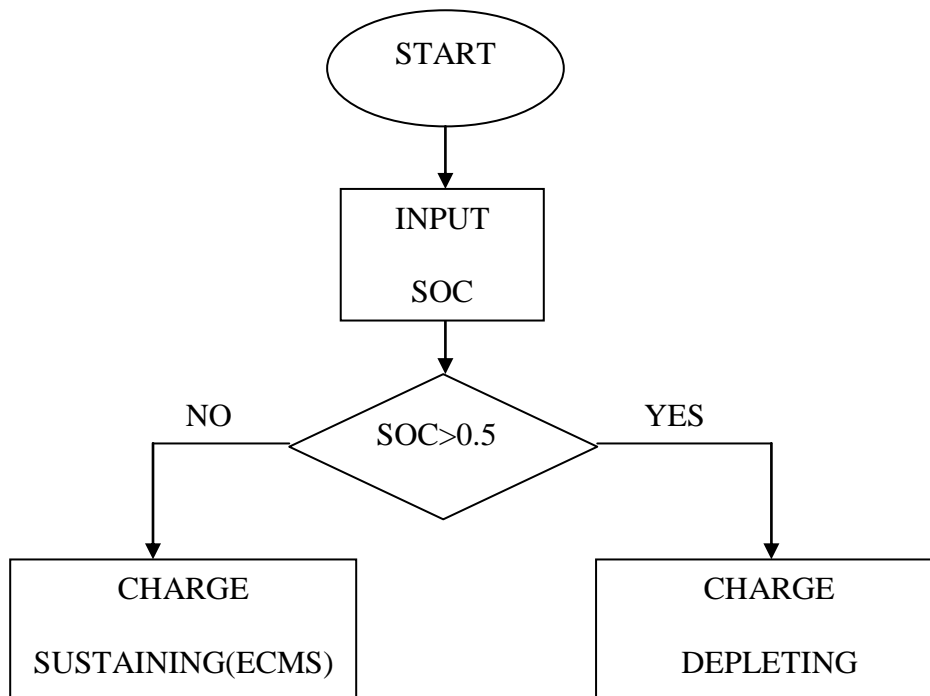
- Charge Depletion mode
- Charge Sustaining mode

In charge depletion mode, the vehicle has the capacity to use its off-board energy and run the vehicle in almost pure electric mode. The engine turns on only when the power demand crosses a particular threshold. Charge sustaining mode is activated when the state of charge falls below a particular threshold and in this mode optimization based on ECMS is implemented. The difference in calculation of fuel consumption in both is based on the fact that in charge depletion mode a direct conversion factor of electrical energy to fuel is considered depending on the cost of electricity and fuel and in charge

sustaining mode this is carried out by assigning future costs and future savings to the present usage of electrical energy.

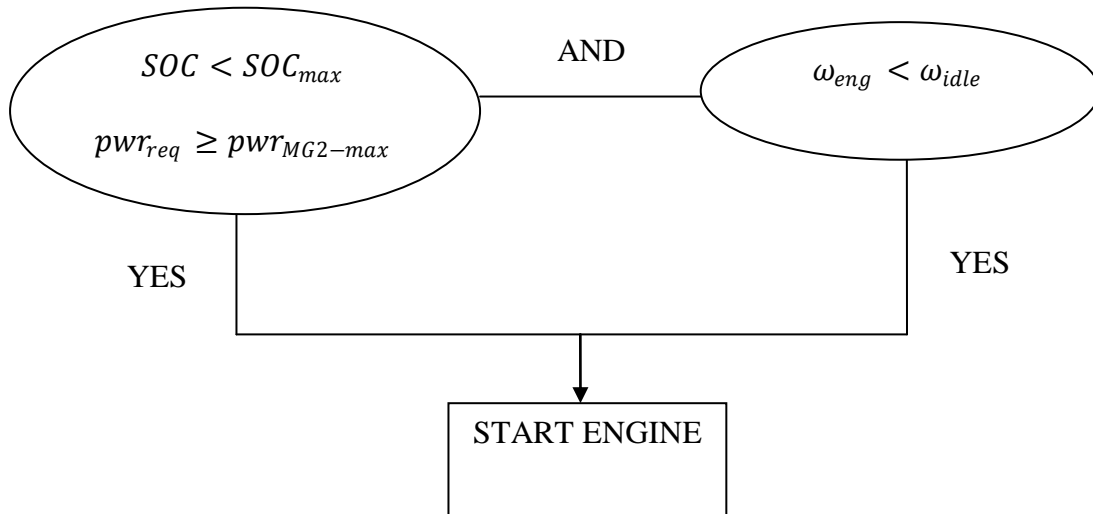
The supervisory controller acts in two modes in the following way. Implementation inside the supervisory control is by far the same in a forward modeling approach and backward modeling approach except for a the dynamics that has been neglected in the backward model.

#### 4.1 Implementation inside the supervisory controller



**Figure 4-1: Controller Chekcing for SOC limits**

#### 4.1.1 Implementation in Charge Depletion mode



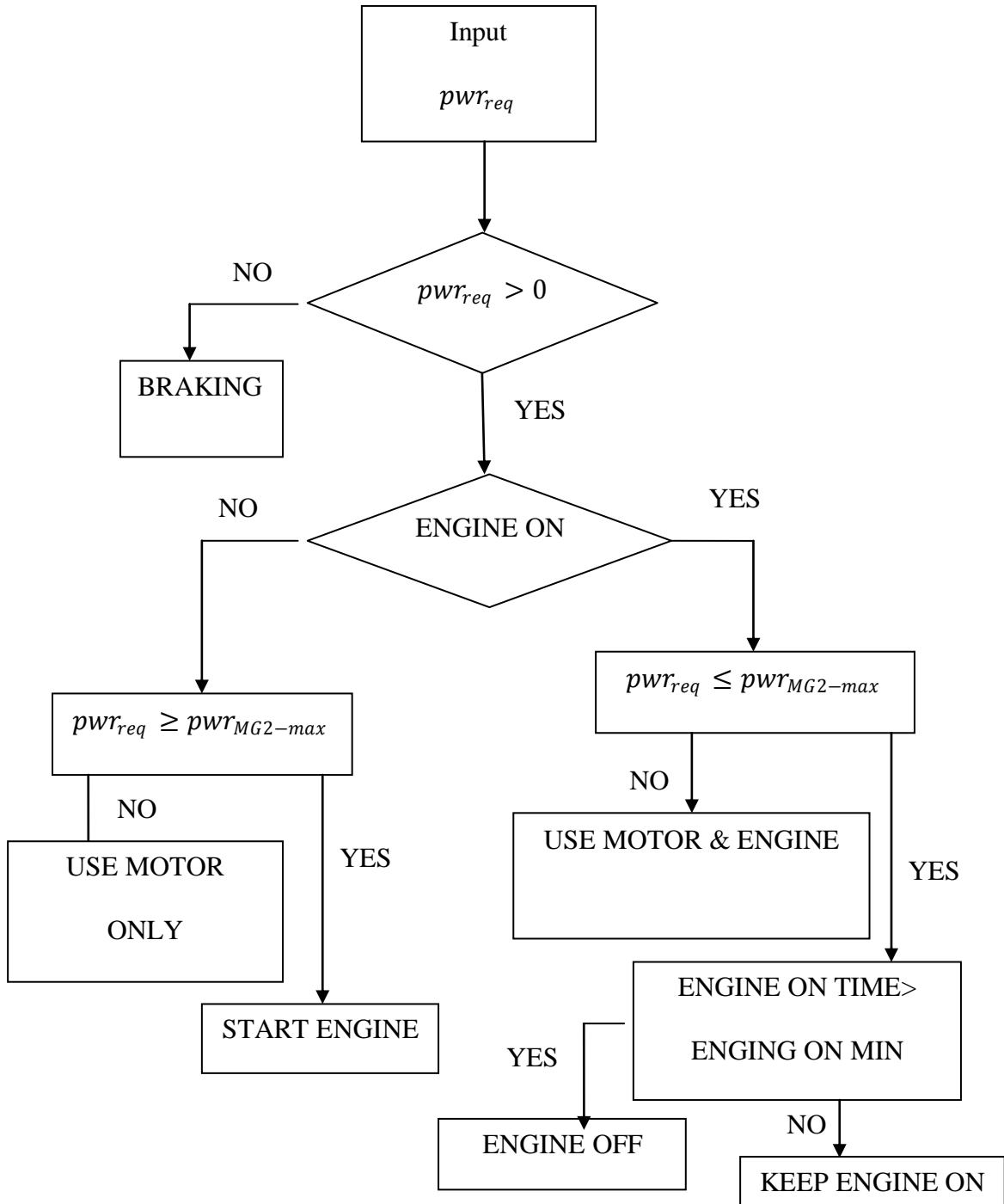
**Figure 4-2: Engine On/Off Strategy**

The Figure 4-1 shows the schematic representation of controller switching between charge Depletion mode and ECMS. And similarly the Figure 4-2 shows the engine turning on and off when the power request is more than the power provided by the motor coupled directly to the ring gear. When the engine is ON which is shown in the Figure 4-3: Algorithm for power flow in charge depletion mode, the controller decides to turn the engine OFF or keep it ON depending on the power-request and the ENGINE ON/OFF time which is calculated inside the supervisory controller based on the engine current speed and optimal speed of the engine.

Here  $SOC_{max}$  = State of charge for the ECMS operation to trigger

In this research we choose it to be 0.5.

$$SOC_{max} = 0.5$$

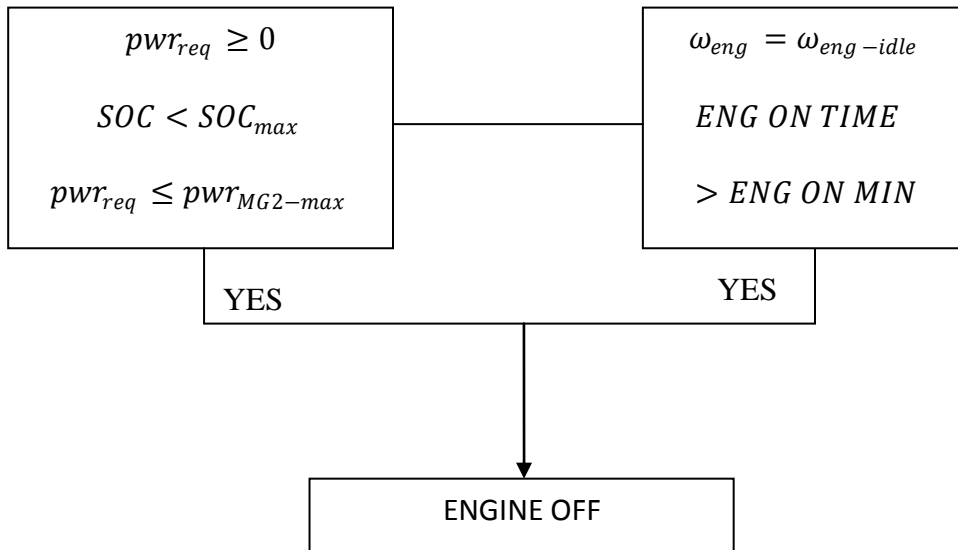


**Figure 4-3: Algorithm for power flow in charge depletion mode**

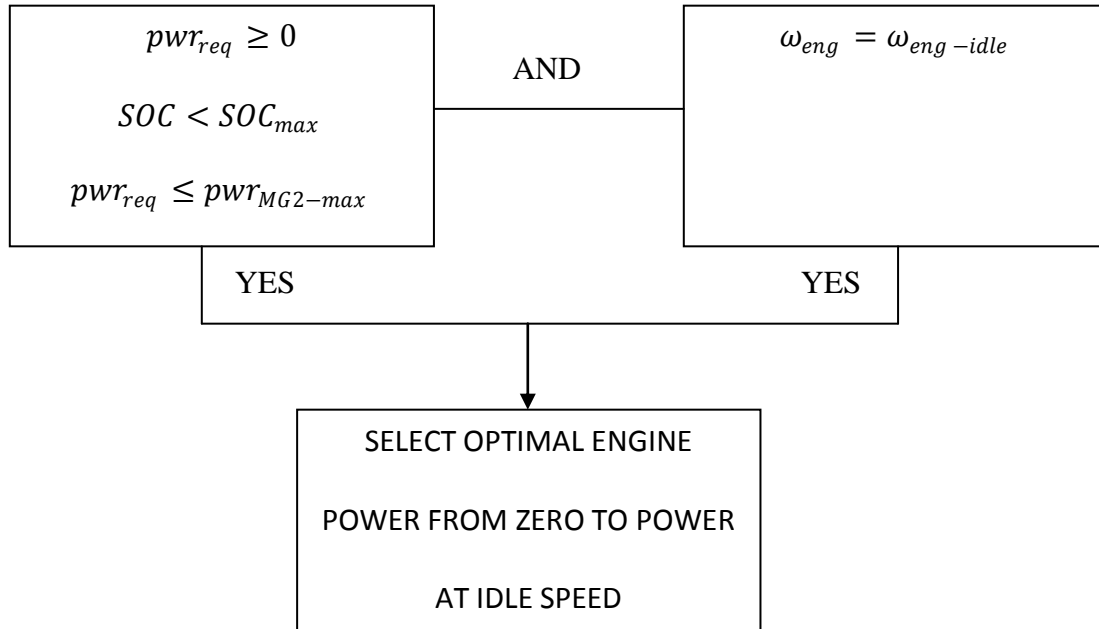
In this case as shown in the figure the controller decides the engine power during the engine ON condition depending on the engine ON time. In the backward model, both

the speed and power are decided inside the supervisory controller, but in the forward model speed is the outcome of power based on the equation () that is calculated outside the supervisory controller in the engine dynamics block. This speed is the integral of the torque and this speed is saturated between the limits idle speed and maximum engine speed. The engine speed becomes zero when the engine is on for more than the engine ON minimum time and when the engine power becomes zero. The only difference in both the modeling approaches lies in the fact that the engine speed and engine power are dictated by the supervisory controller in backward model, but in forward model the speed is derived from the dynamic power balance equation as an outcome of power.

#### 4.1.2 Implementation in charge sustaining mode

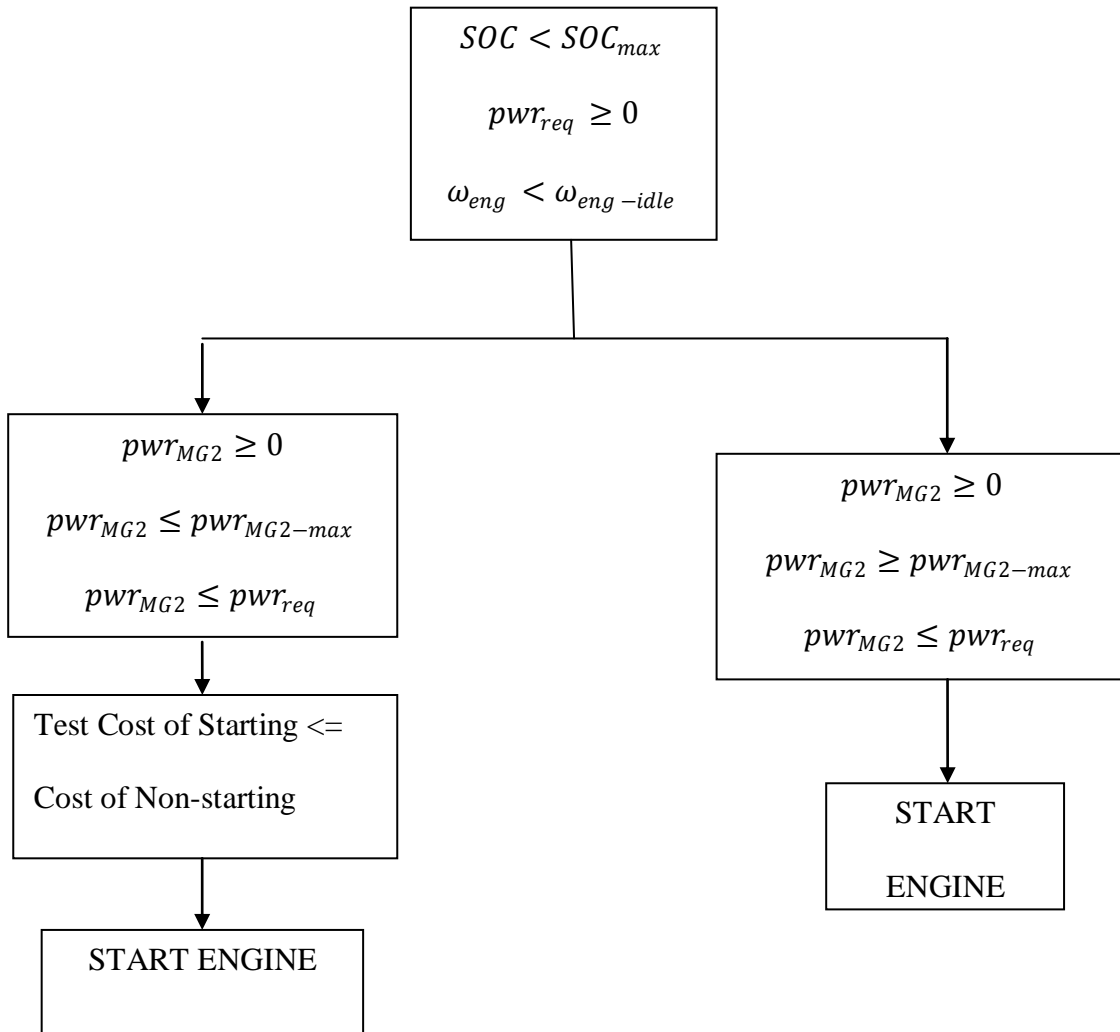


**Figure 4-4: Control logic when engine is ON for more than the minimum time for which it can be on before turning off**

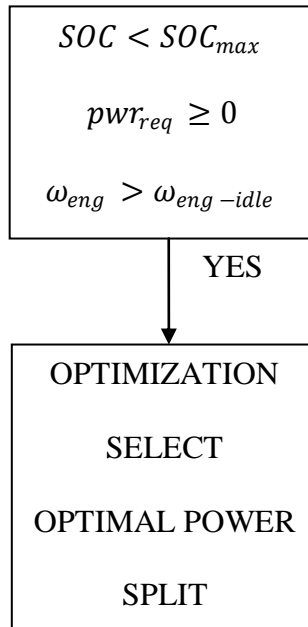


**Figure 4-5: Control logic when the engine is ON**

The Figure 4-4 & Figure 4-5 show the control logic that is implemented when the engine speed is equal to idle and the power request is less than the maximum power provided by the motor. These figures show that when the engine is running at idle speed and when the power demand at the wheels is less than the maximum power the motor attached to the ring gear can provide, the engine ON/OFF logic is based on the time for which the engine is ON. If the engine is ON for more than the time for which it can be ON before turning OFF, the controller decides to turn off the engine and in case the engine is on and time for which it is on is less than the minimum time for which it can be ON before turning OFF, the controller optimally splits the power between the two actuators motor and engine. This optimal split is implemented such that at any given instant the equivalent fuel consumption is the least.



**Figure 4-6: Control logic when engine speed is less than idle speed**



**Figure 4-7: Control Logic when engine speed is more than idle speed**

The Figure 4-6 represents the control logic when the engine speed is less than the idle speed. The power flow diagram represents the power distribution in this case. When the power request is less than the power that can be provided by the motor, the controller compares the cost of starting the engine and using the battery to using the battery alone. When engine speed is more than idle speed and when power request is more than zero we implement ECMS that selects the best possible power split between the actuators that minimizes the fuel consumption. This is shown in Figure 4-7.

Though the control logic for the forward model is same as it is in the backward model, the Engine ON time is calculated in a different way in the forward model. Since the engine speed is calculated based on the equation, the speed is calculated as an integral and inside the engine dynamics block we saturate this integral to be between the limits idle and maximum engine speed. The engine speed becomes zero only when the engine



is on for more than the time specified by the Engine minimum on time and the power delivered by the engine (coming as an output from supervisory controller) becomes zero. Since the integral saturates the engine speed outside the supervisory controller and in the engine dynamics subsystem, it is slightly different from the backward model far as the implementation is concerned in MATLAB/Simulink, but the inherent logic is the same.

#### 4.2 Differences in Practical implementation between Forward modeling approach and backward modeling approach

In this present research we have modeled a power-split plug-in hybrid electric vehicle by using two approaches. The first one was backward modeling approach and the second is slightly different form of modeling which removes any assumptions we considered in backward approach. The backward model was more of a simplistic model as it moves forward by assuming that the power at the wheels is distributed and is always met. This cannot be applied in modeling real time systems as the real power-train has to have a driver block which computes the power demand which is different from the one computed in the backward model. The supervisory controller on the other hand in the backward model assumes certain dynamics without having any real time blocks. It computes the output and the controller decides the speed of the individual actuators based on the control inputs and the states and this eliminates the use of any individual subsystems. The individual subsystems are used only to check for the efficiency losses. The supervisory controller in the forward model does not have any control on the speed. It computes the control inputs to suit the power demand and based on the outputs

provided by the higher level controller the real speed of the actuators is computed. The power provided by the supervisory controller is given as an input to the individual systems to check for the limitations. The forward model proceeds from the driver through the power-train to the wheels. This is schematically represented in

Component Sizing for the power-train in the dissertation

The power-train components and sizing used in the dissertation is the THS-II configuration released by Toyota corporation in the year 2004[22]. The 2004 Production Prius is limited to charge sustaining operation only[22]. The Hymotion PHEV introduced by Toyota had an additional battery pack to have the charge depletion operation accomplished. The Production Prius had a 6Ah, 1.3kWh, with charge sustaining operation. The Hymotion Prius which is a PHEV had an additional 5kWh battery pack. This combined battery pack weighed 73 kg when compared to the 44kg battery pack of the production Prius. The Hymotion Prius used a lithium ion battery pack which reduces the weight considerably and provides the same capacity for a lesser weight. Thus the capacity to weight ratio is much better for the lithium ion battery pack, which provides thrice the capacity for the same weight when compared to Nickel Metal Hydride battery. In the present configuration used in the dissertation we use the THS-II component sizing with the battery capacity increased to thrice since this configuration uses Lithium Ion battery pack[22].

#### 4.3 Simulation results

Hitherto mentioned ECMS(instantaneous minimization strategy) has been applied for the two approaches i.e. backward and forward and the results are tabulated. The

simulator is a plug-in hybrid electric vehicle and hence the ECMS strategy is applied after the state of charge of the battery reaches the threshold mentioned in the supervisory controller. Hence the applied ECMS strategy helps one realize a charge sustaining pattern. The charging and discharging parameters( $S_{chg}, S_{dis}$ ) are cycle dependent and tuned to get the minimal fuel consumption and also charge sustaining pattern. The fuel economy results and the system performance curves are tabulated for a backward model and forward model. We tabulate the results for two cycles, the city cycle(FUDES or UDDS) and the Federal Highway driving schedule.

In order to apply ECMS and comply with the strategy that has been formulated, one needs to start in the charge sustaining pattern. The charge depleting pattern does not involve any optimization and hence the vehicle is operated mostly in electric mode and the equivalent cost of electricity in terms of fuel is presented.

#### 4.3.1 Fuel economy for UDDS/FUDES cycle and FHDS cycle for charge sustaining strategy

In this test, the simulation results for the simulation of the city cycle are presented(FUDES) and highway cycle(FHDS) are presented. The Cycle essentially is of duration 1369 seconds and the cycle is repeated five times to see for the charge sustaining pattern. FHDS cycle is of duration 770 seconds and the cycle is repeated five times. The SOC of the battery starts at 0.5 and with the tuned parameters for that cycle it is well maintained between 0.5 and 0.4.

Driving Cycle	$S_{chg}$	Mileage(MPG) Equivalent fuel consumption
UDDS	2.4	56.55
FHDS	3.5	71.44

**Table 4-1: Fuel consumption results for backward Model**

Driving Cycle	$S_{chg}$	Mileage(MPG)
UDDS	2.2	56.87
FHDS	2.6	63.02

**Table 4-2: Fuel consumption results for Forward Model**

The fuel consumption results show the fuel economy for two cycles i.e. city cycle and highway cycle. The optimal values for the coefficients were found by running the cycle over a range of values chosen in order to select the ones that produce the minimum fuel consumption for each cycle. The values for found by discretizing the charging and discharging coefficients and running the simulations over a grid of chosen values. This gives us the value for which fuel consumption is minimum.

These results obtained from ECMS show a close similarity to the results obtained from Dynamic Programming for THS configuration [14], which is set as a benchmark for optimization of fuel economy.

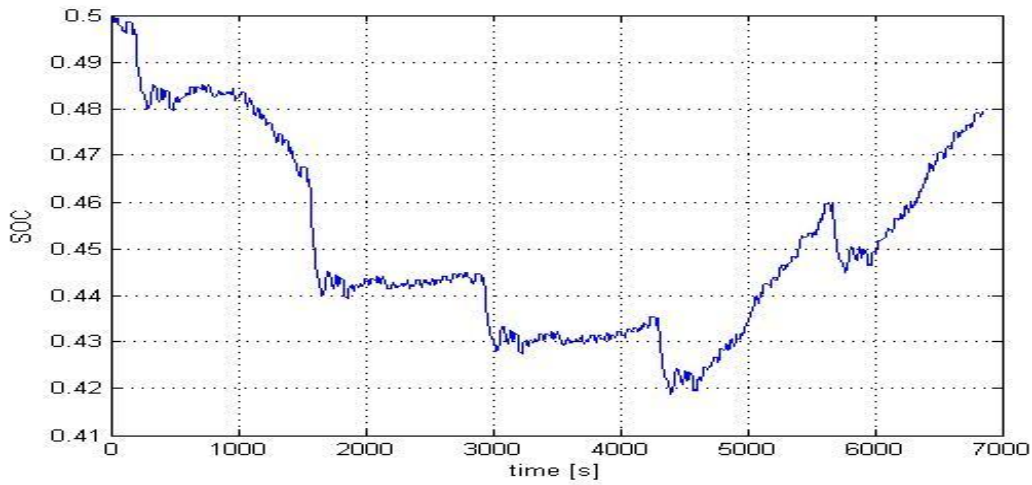
Driving Cycle	Mileage(MPG)
UDDS	57
FHDS	67

**Table 4-3: Fuel economy for Toyota THS configuration using DP( adapted from[14])**

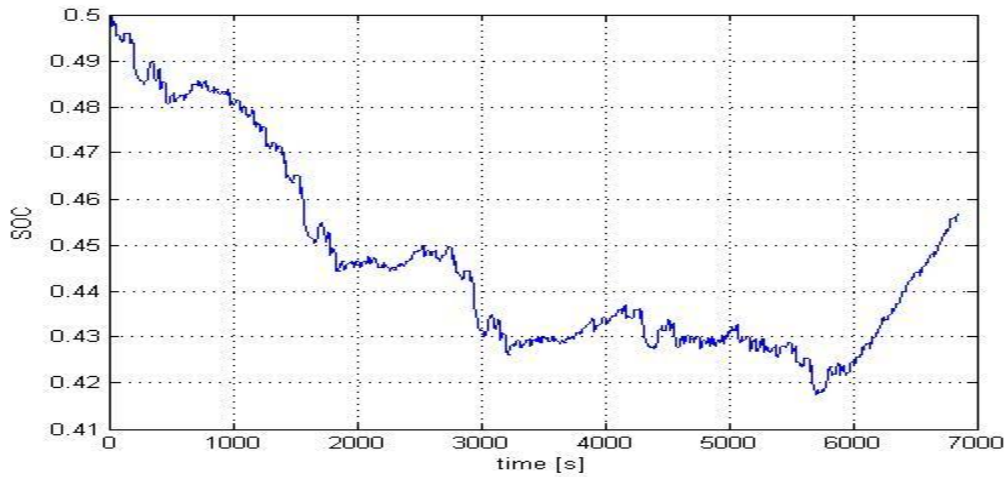
The following figure Figure 4-8: Plot of SOC Vs Time shows that the vehicle realizes a charge sustaining pattern within 0.5 and 0.4. The state of charge is maintained with the limits prescribed by the controller for ECMS. The State of charge variation reflects the way in which the coefficients ( $S_{chg}, S_{dis}$ ) have been tuned. A good tuning of these parameters would result in least fuel consumption and SOC sustainability. In order to test the validity of ECMS, the simulation was performed over a longer range and the values of the charging and discharging coefficients were found that would minimize the fuel consumption and also that would result in SOC sustainability. The SOC initial value was taken to be 0.5 and the charge sustaining operation was also between 0.5 and 0.4. The cycle was repeated several times and the optimal coefficients were found by running the cycle over a grid values chosen for optimization. The coefficients thus tuned minimized the overall fuel consumption and at the same time maintained the state of charge between the limits 0.5 and 0.4, final state of charge being in between 0.45 and 0.5. Since these coefficients were tuned to the driving cycle and since the coefficient is constant over the whole cycle, this coefficient is tuned for minimization of overall fuel

consumption of the whole cycle. The deviation between the final SOC and initial SOC(0.5) is converted into energy and hence into additional cost in terms of fuel. In reality the coefficients are not constant over the cycle since the cycle is not known a priori. In such cases, with aid from GPS, a mission is constructed using the past data and data from GPS. The mission length is selected such that the solution obtained is close to the one obtained for the whole cycle. The pair of optimal values of  $(S_{chg}, S_{dis})$  has to be calculated by imposing charge sustainability for the mission[15].

#### 4.3.1.1 Time history plots for UDDS cycle

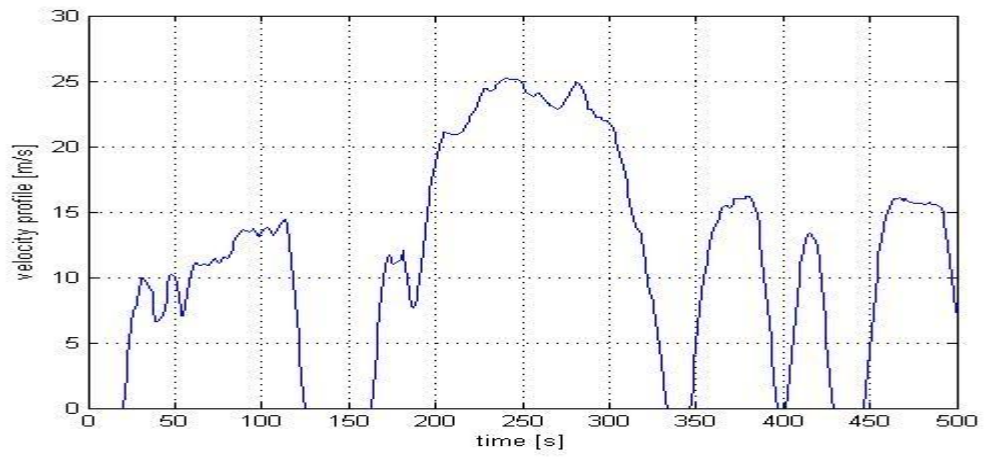


**Figure 4-8: Plot of SOC Vs Time for backward model**

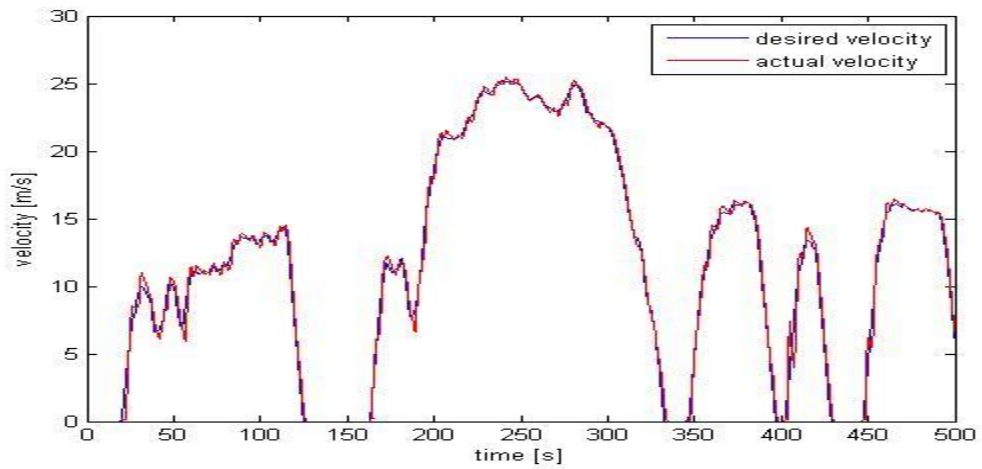


**Figure 4-9: Plot of SOC Vs time for Forward model**

The Figure 4-10 and Figure 4-11 represent the vehicle speed for the first 500 seconds for backward and forward modeling approaches. The velocity in the backward model is just the velocity of the driving cycle. In the forward model, the vehicle velocity is superimposed on the driving cycle velocity. Since the forward model incorporates the driver model, the error between the actual vehicle velocity and driving cycle velocity is used in calculating the power demand. Here in the velocity profile for forward model, the vehicle is trying to follow the speed imposed by the driving cycle. There will a certain error each time which is translated into power demand and the vehicle tries to meet it in the next second.

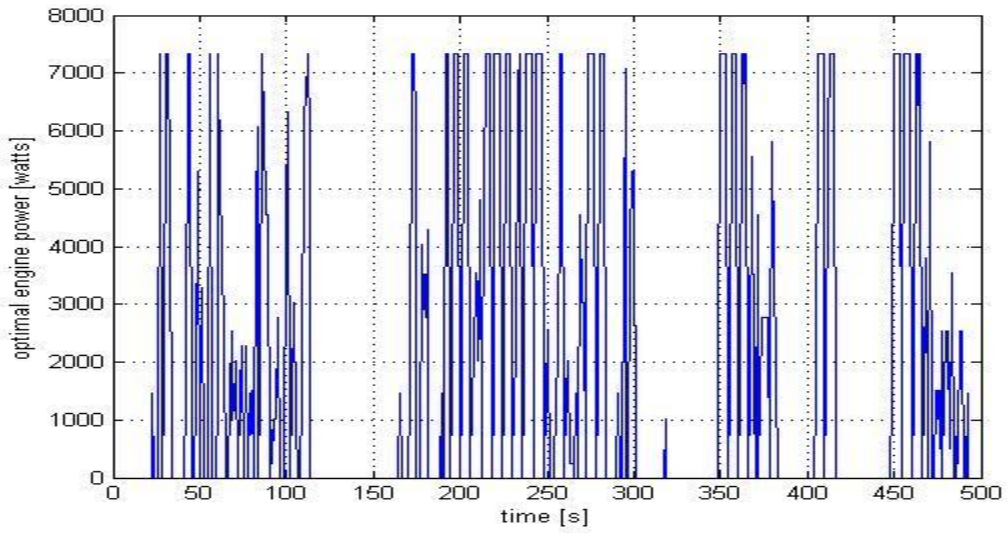


**Figure 4-10: Velocity profile for backward model**

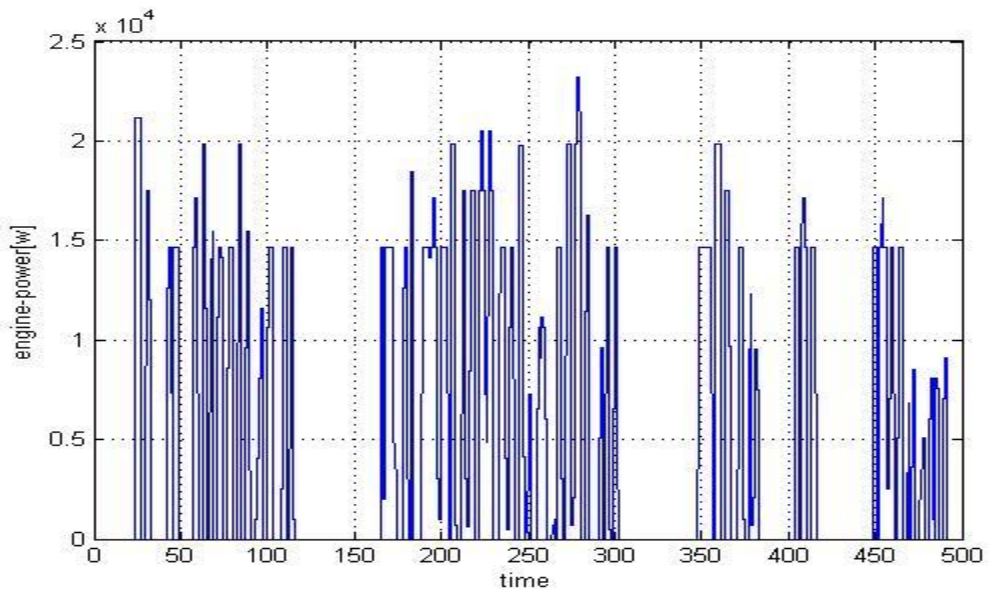


**Figure 4-11: velocity profile for forward model**



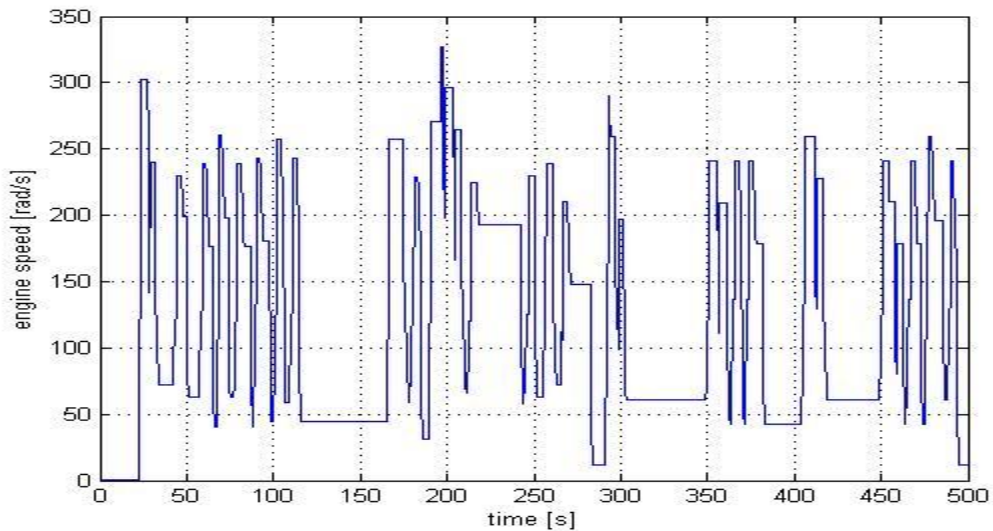


**Figure 4-12: Optimal Engine Power for backward model**

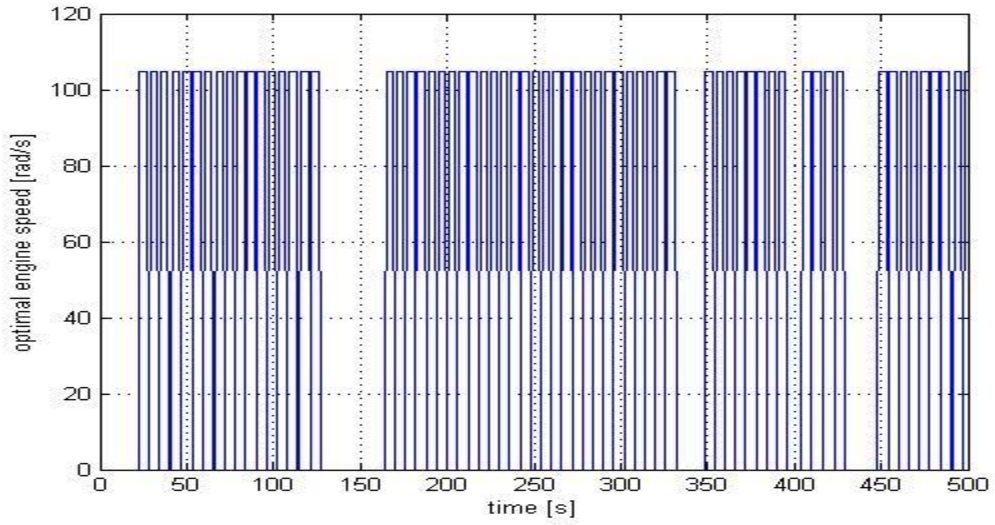


**Figure 4-13: Optimal engine power for forward model**

The Figure 4-12 and Figure 4-13 represent the engine power for backward and forward model for the first 500 seconds. The engine speed and engine power in a backward model are outputs from the controller and during the engine start the modeling assumes that the engine starts in 0.8 seconds with the help of Motor/generator(MG1) acting as motor. Since the higher level controller is triggered every one second and the absence of engine dynamics makes the controller decide the engine speed. The controller assumes that the engine is started in 0.8 seconds and the in 0.2 seconds the Motor/generator(MG1) reverses its operation and functions as generator with the aid of engine. This in the forward model makes things different by not assuming the speed and calculating it as a real time entity.

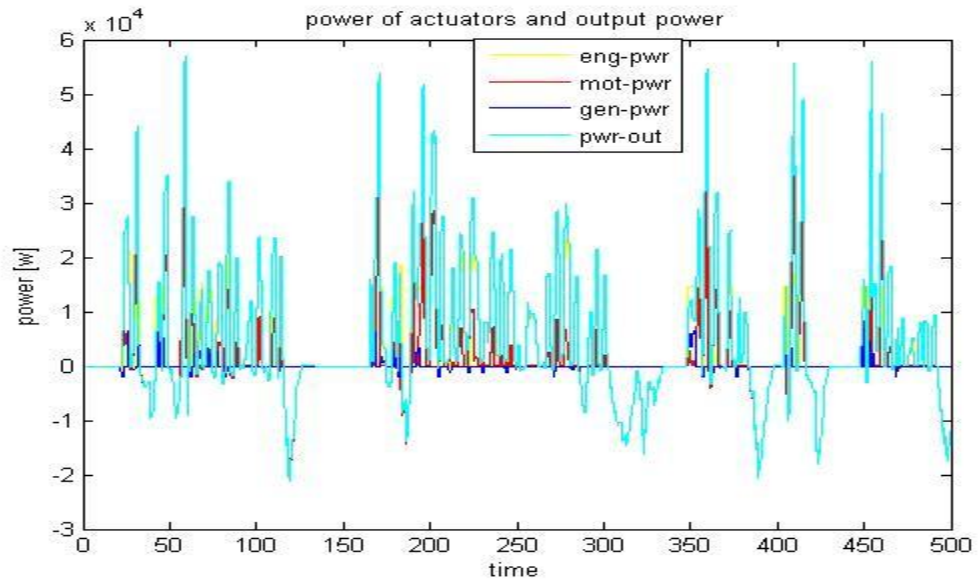


**Figure 4-14: Optimal Engine Speed in Forward model**

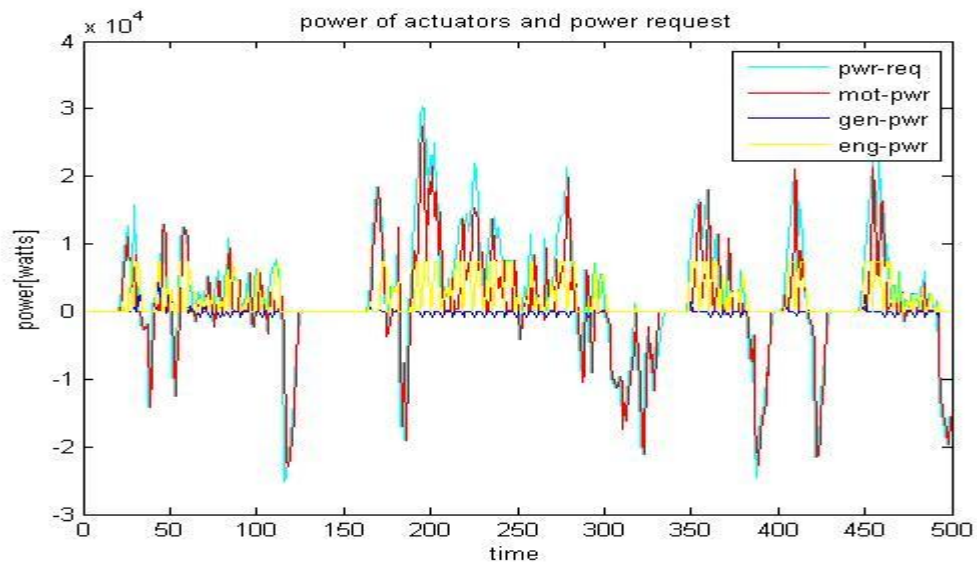


**Figure 4-15: Optimal Engine speed for backward model**

The Figure 4-14 and Figure 4-15 represent the time history plots of engine speed in forward and backward models.

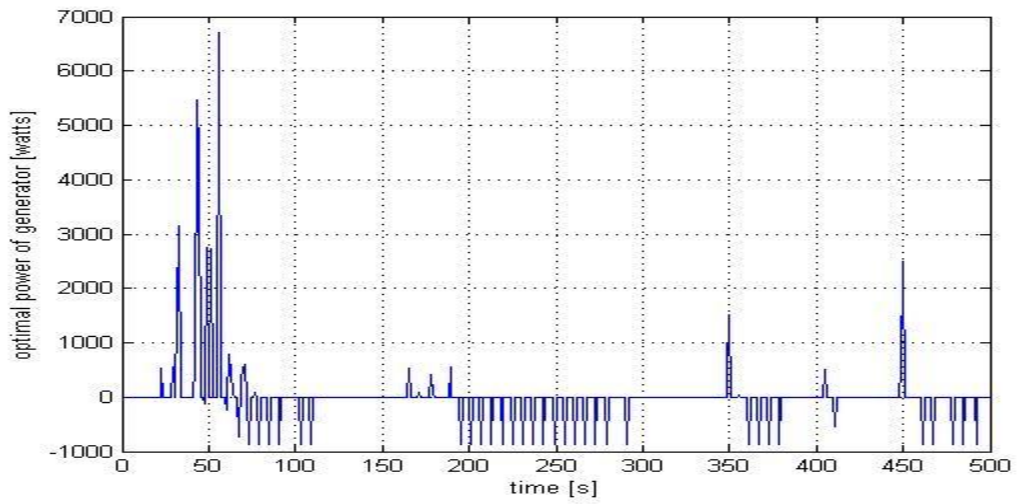


**Figure 4-16: Power curves for Forward model**

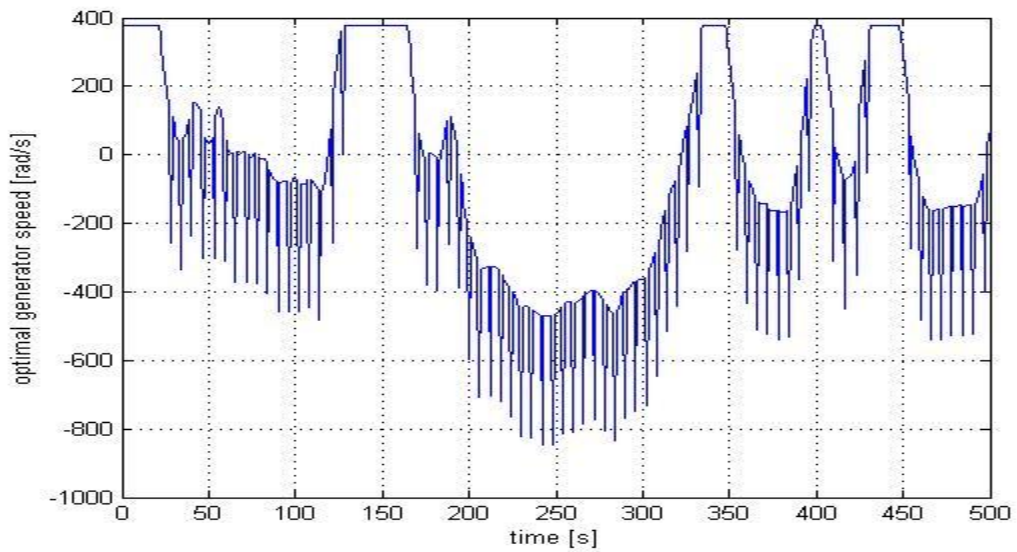


**Figure 4-17: Power curves for backward model**

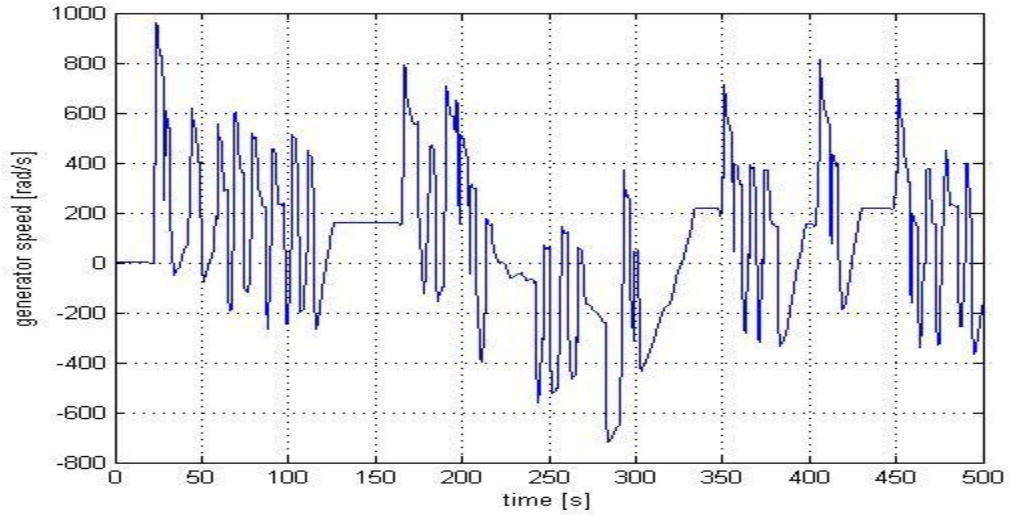
The Power curves in Figure 4-16 and Figure 4-17 show that the power demand is split among different actuators in both forward and backward approaches. In backward model, the power request is always assumed to be met. In the forward model, in the event the power demand is not met completely, since it is a forward modeling approach the power demand is carried forward so that it is met during the next second. The negative power peaks of the generator power in the power curves indicate the generator(MG1) is functioning as a starter motor. The negative power in the power-curve for the motor power(MG2) indicate recuperation during braking. The energy recuperated is given back to the battery and hence can be used in future to propel the vehicle.



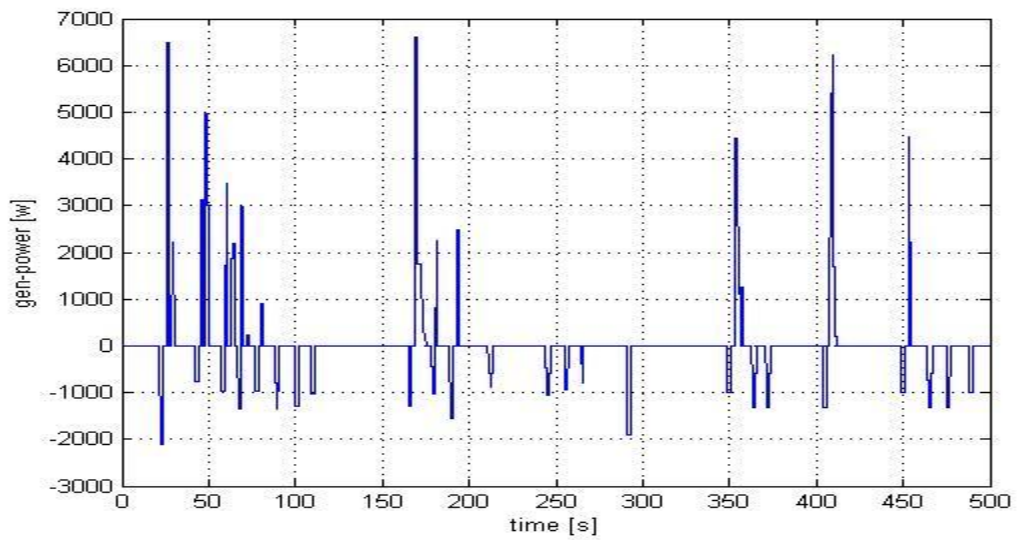
**Figure 4-18: Optimal Generator Power for backward model(MG1)**



**Figure 4-19: Optimal generator Speed for backward model(MG1)**



**Figure 4-20: Optimal generator speed for forward model(MG1)**



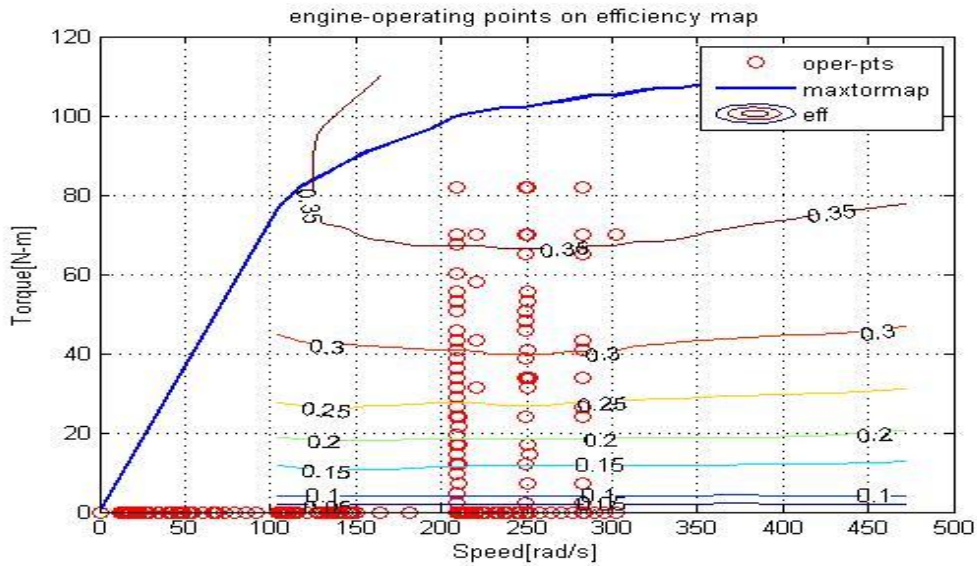
**Figure 4-21: Optimal generator power for forward model(MG1)**

The Figure 4-18 represents the power of the generator(MG1) in the backward model. The sign convention that has been used in this research is that the power is positive when the generator is working with assistance from engine and the power is negative when the generator is working as a starter motor to start the engine. Here the generator as assumed works as a starter motor when the engine is required to be started. The generator reverses its operation from motor to generator immediately as the engine is started. Here in Figure 4-18, the negative power peak indicates that the generator (MG1) is functioning as a generator. The engine is started in 0.8 seconds and during this 0.8 seconds the generator power is negative and in the 0.2 seconds the generator power is positive. The net power calculated is the summation of these two powers within the one second fixed time step. Even after the engine starts if the optimal speed calculated from the speed relation is negative, the generator is only used to start the engine and does not work as generator. Hence the net power is negative This is evident from the Figure 4-18 and Figure 4-19 between 200 and 300 seconds.

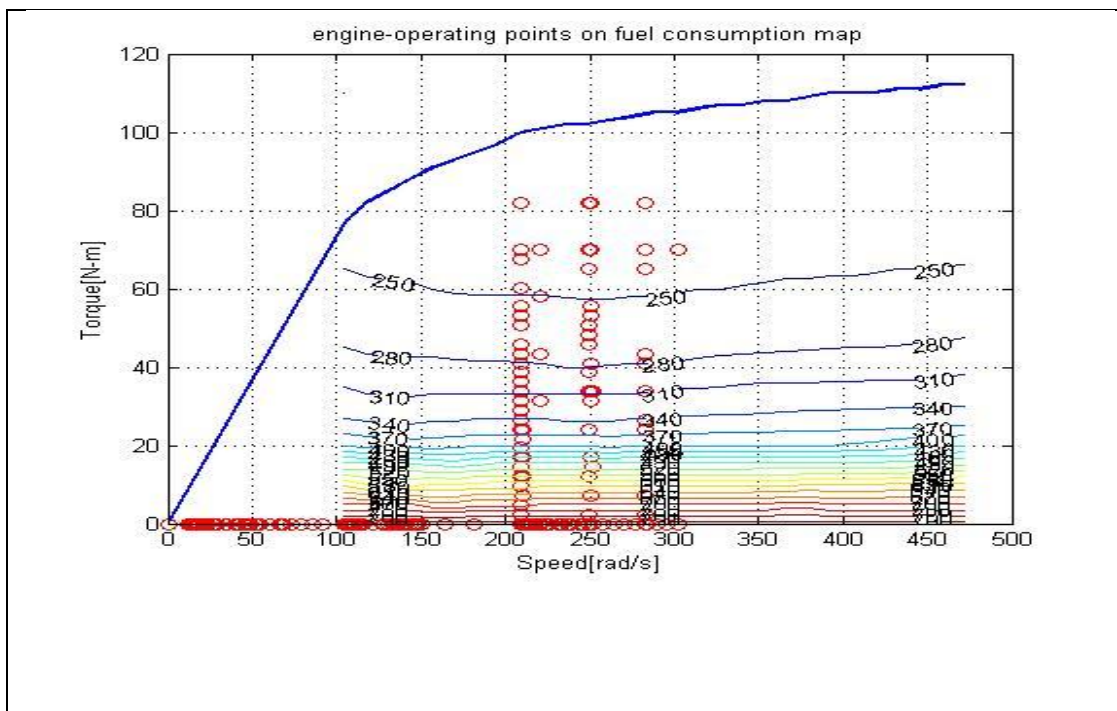
The following plots show the operating points of engine on the efficiency and fuel consumption maps. The operating points are plotted to check for the operation of engine at different loads and also to check for the validity of ECMS. The Operating points are plotted of engine over the efficiency map are plotted for both forward facing and backward facing models for the first 500 seconds of the UDDS cycle. The engine operation within the higher level controller always minimizes the overall fuel consumption i.e. the equivalent fuel consumption. When the engine speed is more than



the idle speed, the controller that power from the engine that minimizes the equivalent fuel consumption.



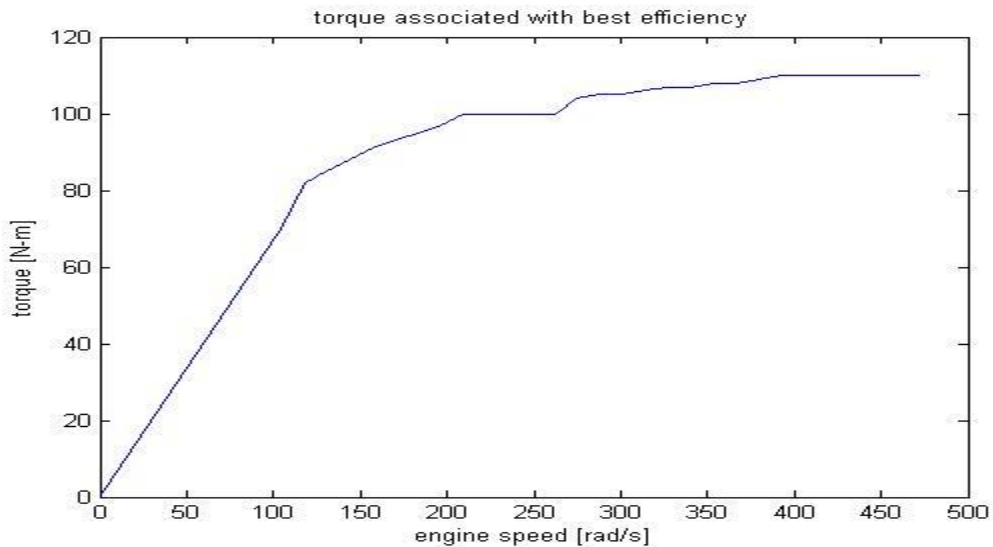
**Figure 4-21: Operating points of engine over efficiency map for forward model**



**Figure 4-22: Operating points over fuel consumption map**



The penalty function embedded within the equivalent fuel consumption always maintains the charge within the region prescribed for charge sustenance. In this way, when the engine speed is more than the idle speed, the controller minimizes the fuel consumption and hence splits the power optimally between the actuators. If the engine speed is equal to idle speed, depending on the engine ON/OFF time and also depending on the power request, the engine power is chosen from zero to the power at idle speed. This optimization picks up the power that minimizes the overall equivalent fuel consumption. One can see from the plots that the engine operating at highest efficiency points has comparatively lesser fuel consumption than the ones at lower efficiency.



**Figure 4-23: Engine Torque associated with best efficiency**

The Figure 4-23 shows the engine torque associated with best efficiency. The torque or power that corresponds to the best efficiency line is selected for different speeds and this is used during the optimization process. The engine speed is discretized and the

corresponding control variable is selected that satisfies the objective of minimizing the fuel consumption. This control variable always corresponds to the best efficiency line. The algorithm for the same power demand selects the points which gives the overall minimum fuel consumption.

#### 4.3.2 Calculation of fuel consumption in Charge Depletion Mode

Although the charge depletion mode in a plug-in hybrid electric vehicle is mostly electric, the engine is turned on and off during high power demands. This makes it necessary to calculate the costs associated with this fuel usage and also the range in pure electric operation. We follow the calculation prescribed in[22] to calculate the mileage and also the miles driven in electric mode. Here we use the term Petroleum displacement factor, to determine how aggressively petroleum is used in charge depletion mode when compared to charge sustaining operation[22].

**Petroleum Displacement Factor**(Adapted from [22])

$$= \left( 1 - \frac{\left( \frac{1}{MPG_{CD}} \right)}{\left( \frac{1}{MPG_{CS}} \right)} \right) \quad (4.5)$$

This petroleum displacement factor is in turn used to calculate the range the vehicle can drive if the vehicle were to operate in purely electric mode. This is defined as

**PHEV equivalent**(Adapted from [22])

$$= \left( 1 - \frac{\left( \frac{1}{MPG_{CD}} \right)}{\left( \frac{1}{MPG_{CS}} \right)} \right) * Miles_{CD} \quad (4.6)$$

This two equations are used to calculate the range of PHEV if the vehicle drives in purely electric. The operating costs assume the cost of fuel and electricity as 0.1\$ per kWh and 2.6\$ per gallon[18, 19]. We tabulate the results using the two equations above for PHEV equivalent and charge depletion range for both Forward and backward model approaches for UDDS and FHDS cycles.

For the charge depletion operation we start the operation at State of charge of the RESS(battery)= 0.8 and we allow it to drop till it reaches the upper limit of the charge sustenance phase( 0.5). In this range the vehicle is mostly driven with electric energy except for instances when the battery power is not able to meet the power demand. Hence this range cannot be termed as purely electric. In charge depletion operation- though the engine is working, it is not used to charge the generator and hence this makes the cost calculation different from ECMS. We relate the cost of electricity to the cost of fuel and hence calculate the equivalent costs. The following results give us a good idea about the cost calculation. The first tabulated results indicate that the cycle is repeated until the vehicle reaches the charge sustenance phase. The energy consumed by the battery in pure electric mode is calculated as the integral of the power delivered by the battery. The charge depleting mode has some assistance from engine during instances of high power request. Hence the miles traveled until the charge drops to the region of charge sustenance cannot be termed as the miles traveled in pure electric mode. This introduces a new term known as PHEV equivalent which computes the actual miles traveled by calculating the amount of fuel used by ICE in charge depletion mode. This tradeoff during high power demand is termed as petroleum displacement factor[22].

UDDS	1 <sup>st</sup> cycle	2 <sup>nd</sup> cycle	3 <sup>rd</sup> cycle	4 <sup>th</sup> cycle
Fuel used[gal]	0.00073	0	0	0
Electricity used[kWh]	0.78	0.79	0.79	.7056
Cost of fuel[\$]	.0019	0	0	0
Cost of electricity[\$]	0.078	0.079	0.079	0.07
Miles Driven	7.4	7.4	7.4	6.4

**Table 4-4: Results for Charge depletion mode for UDDS cycle for backward model**

The fourth UDDS cycle here is not purely charge depletion since it reaches the charge sustenance phase before the cycle gets completed. Hence we take into consideration only that phase till it reaches charge sustenance operation. The next table shows the results tabulated for the UDDS cycle. The PHEV equivalent is calculated using the equation

The cost of electricity and cost of fuel used is tabulated. The  $MPG_{CD}$  term used in the equation represents the miles per gallon in the Charge depletion mode. This is calculated based on the amount of petroleum used in the charge depletion mode and the total miles traveled in charge depletion mode.

Driving Cycle	Fuel Used[gal]	Electricity used[kWh]	Cost of fuel[\$]	Cost of Electricity[\$]	PHEV equivalent
UDDS	.00073	3.06	.0019	0.306	28.1miles

**Table 4-5: Fuel economy results for UDDS CD range for a backward model**

UDDS	1 <sup>st</sup> cycle	2 <sup>nd</sup> cycle	3 <sup>rd</sup> cycle till it reaches charge sustenance
Fuel used[gal]	0.005	0.005	.0003
Electricity used[kWh]	1.2	1.2	.5
Cost of fuel[\$]	0.013	0.013	.0007
Cost of electricity[\$]	0.12	0.12	0.05
Miles Driven	7.4	7.4	3.4

**Table 4-6: Results for Charge depletion mode for UDDS cycle for Forward model**

Driving Cycle	Fuel Used[gal]	Electricity used[kWh]	Cost of fuel[\$]	Cost of Electricity[\$]	PHEV equivalent
UDDS	.08	3	0.21	0.3	18.12miles

**Table 4-7: Fuel economy results for UDDS CD range for forward model**

Here in the forward model, the vehicle enters the charge sustenance phase before the completion of the third cycle. This can be attributed to the fact that the difference in SOC drop between forward and backward models is 0.04 per cycle. After the completion of one cycle the SOC in backward model drops from 0.8 to 0.72, but the state of charge in the backward model drops from 0.8 to 0.68. For the same operational miles the miles per one percent change in SOC is more slightly more in the case of backward model. The forward model is a more realistic model which includes a driver block and calculates the power based on the driver inputs such as throttle and brake commands. Hence the power request in both the models is slightly different. This is because as the modeling becomes complicated, it becomes difficult to exactly track the velocity pattern of the drive cycle with zero error. There will be instances when the simulation responds slowly, during hard braking and hard acceleration. Hence after the lag during hard braking, there will be lag in the initial acceleration. The tuning of driver should be extremely fine to take into account sudden braking and sudden acceleration, which becomes complicated in reality. Hence there will be a tradeoff between fuel consumption and the tuning. The backward version is more simplified version and hence the interpretation of power request becomes simpler and it is saturated between the limits whenever it crosses the component

limitations. The forward model is just driver based and at each instant the power request depends on the throttle and brake commands given by the driver. This can cause a slight difference between the models and the mileage differs slightly.

Driving Cycle	miles per one percent change in SOC for Backward model	miles per one percent change in SOC for Backward model
UDDS	0.92	0.61

**Table 4-8: Miles per percent change in SOC for UDDS cycle**

FHDS	1 <sup>st</sup> cycle	2 <sup>nd</sup> cycle	3 <sup>rd</sup> cycle till charge sustenance
Fuel used[gal]	0	0	.05
Electricity used[kWh]	1.31	1.31	0.8
Cost of fuel[\$]	0	0	0
Cost of electricity[\$]	.131	.131	0.08
Miles Driven	10.3	10.3	4.4

**Table 4-9: Results for Charge depletion mode for FHDS cycle for backward model**

Driving Cycle	Fuel Used[gal]	Electricity used[kWh]	Cost of fuel[\$]	Cost of electricity[\$]	PHEV equivalent
FHDS	.05	3.5	.13	0.35	24.7 miles

**Table 4-10: Fuel economy results for FHDS CD range in backward model.**

FHDS	1 <sup>st</sup> cycle	2 <sup>nd</sup> cycle	3 <sup>rd</sup> cycle till charge sustenance
Fuel used[gal]	0.0009	0.0008	0
Electricity used[kWh]	1.41	1.44	0.6
Cost of fuel[\$]	0.0024	0.0021	0
Cost of electricity[\$]	0.141	.144	0.06
Miles Driven	10.3	10.3	4

**Table 4-11: Results for charge depletion range for forward model**



Driving Cycle	Fuel Used[gal]	Electricity used[kWh]	Cost of fuel[\$]	Cost of Electricity[\$]	PHEV equivalent
FHDS	.05	3.5	.13	0.35	22.5miles

**Table 4-12: Fuel economy for FHDS CD range for forward model**

#### 4.4 Differences in Global and Instantaneous fuel minimization approaches

Although the principle applied (ECMS) results in a solution closer to the optimal one. It requires that we tune the charging and discharging coefficients so that the fuel minimization is closed to the optimal solution. These coefficients are cycle dependent and the solution can be obtained if these coefficients are tuned to every situation.[15] Dynamic programming on the other hand cannot be implemented in real life situations as it requires extreme computational power. Hence perfectly tuned parameters for ECMS can be helpful in finding out a solution closed to the optimal one.

Although knowing the whole driving schedule a priori is a tedious task, one can fix a time horizon which is of shorter duration than that of the cycle. With the aid of Global positioning system one can know the future traffic conditions prevailing within a limited time horizon and with the past data one can have a driving cycle that is given as an input to the system [15] Based on this, the parameters ( $S_{chg}, S_{dis}$ ) are estimated and these parameters remain constant for that limited time horizon until a new driving

schedule. This way one can find out the parameters and tune it so that the instantaneous minimization principle can be realized as a global solution.

## CHAPTER FIVE: CONCLUSIONS AND FUTURE WORK

In this dissertation, modeling and simulation of a Plug-in hybrid electric vehicle is carried out using instantaneous optimization technique. The technique used can be applied real time online and is computationally less extensive when compared to global optimization tools. The ECMS strategy implemented for both Forward and backward models provided us with solutions that optimally split power amongst the actuators by moving the operating points to points where fuel consumption is minimized. The vehicle is operated in charge depletion mode until it reaches a charge sustenance mode. This enables us to operate the vehicle in all electric range as far as possible and hence reduces the emissions. If the trip length were small and the engine never operates, the vehicle is said to travel using the off-board electrical energy through the grid. Once the vehicle enters the charge sustaining pattern, the ECMS strategy is implemented. The engine ON/OFF strategy is also implemented and hence the vehicle can be turned off in case the engine is idle for certain amount of time. This considerably reduces the fuel consumption during instances when electrical energy can be used solely to provide the vehicle with the necessary power. The vehicle is also operated in charge depletion range and the mileage or miles that the vehicle can run if the vehicle were to operate without the engine turning on is tabulated. The all electric range considers engine turning on only when the power demand is more than the threshold that motor can provide. The use of power split configuration helps us in optimizing the engine performance.

The drive cycles used here are the normal city and highway cycles( UDDS and FHDS cycles). In reality the parameters that are to be optimized or tuned in ECMS have to comply with the future driving conditions and hence with the aid of GPS(global positioning system), a real time driving scenario can be simulated. This can be of very short durations and is simulated using past and future data. This can be fed to the vehicle controller to optimize or tune the parameters for that cycle. And also the future work includes simulating a blended strategy which enables us to minimize the fuel consumption further. This does not include a charge depletion charge sustaining(CDCS) strategy separately and the vehicle starts from the maximum state of charge of RESS directly using blended mode. This makes the engine to operate at maximum efficiency points even in the charge depletion range which had to be compromised in the CDCS strategy. To realize this mode of operation, one has to tune the charging and discharging parameters used in ECMS separately and these may have some relation with the trip length. The future research in this area will throw more light into subsequent improvement.



## APPENDICES

## Appendix A:

### Nomenclature:

SOC	State of Charge of Battery
$pwr_{start-engine}$	Power to start engine
$pwr_{MG2}$	Power of Motor/Generator predominantly acting as motor
$pwr_{MG1}$	Power of Motor/Generator predominantly acting as Generator
$\omega_{eng}$	Engine speed
$\omega_{ice}$	Engine speed
$\omega_{eng-idle}$	Idle speed of Engine
$\omega_{eng-current}$	Current Engine Speed
$\omega_{eng-opt}$	Optimal Engine speed
$pwr_{req}$	Power Request
$pwr_{eng}$	Engine Power
$pwr_{eng-opt}$	Optimal Engine power
$pwr_{MG2-opt}$ motor	Optimal Power of Motor/Generator predominantly acting as motor
$pwr_{MG1-opt}$ Generator	Optimal Power of Motor/Generator predominantly acting as Generator
$\dot{m}_{f,ICE}$	Fuel Consumption rate of Engine
$\dot{m}_{f,ICE-opt}$	Fuel Consumption rate of Engine(Optimal Value)
$\dot{m}_{f,eqb}$	Equivalent Fuel consumption rate of Battery
$\dot{m}_{f,eqb-opt}$	Equivalent Fuel consumption rate of Battery(Optimal Value)

$\eta_{pe}$	Efficiency of Power electronics
$\eta_{b1}$	Efficiency of battery during Discharge
$\eta_{b2}$	Efficiency of battery during charging
$\eta_{PE}$	Efficiency of power electronics
$\eta_{b,dis}$	Efficiency of battery during discharge
$\eta_{b,chg}$	Efficiency of battery during charging
$S_{chg}$ & $S_{dis}$	Charge and Discharge Coefficients
$Coeff - e - f$	Equivalent cost of electric power in terms of fuel



## APPENDIX B

### Power-train Specifications

Table B-1 **Vehicle Specifications**

Vehicle Mass(Toyota Prius second generation(PHEV))[Kg]	1330
Aerodynamic drag coefficient, $C_d$	.26
Vehicle Frontal area, $A_f [m^2]$	2.16
Rolling resistance Coefficient	0.007
Wheel radius[m]	.3175
Density of Air, $\rho [kg/m^3]$	1.2
Acceleration due to gravity, $g [m/m^2]$	9.81
Final Transmission ratio( $N_f$ )	4.11

Table B-2 **Engine Specifications**

Engine Type	1NZ-FXE DOHC
Displacement(L)	1.5
BORE X STROKE	75 X 84.7
Rater power(kW) @5000rpm	57
Torque(N-m) @4200 rpm	111
Compression ratio	13:1
Engine Inertia[ $Kg/m^2$ ]	0.1598

**Table B-3. Motor/generator Specifications (MG1)**

Continuous Power output(kW)	15
Peak Power output(kW)	30
Motor Inertia[ $Kg - m^2$ ]	.025
Max torque output(N-m)	153.5
Max motor Speed(rpm)	10000

**Table B-5 Motor/generator Specifications(MG2)**

Continuous Power output(kW)	25
Peak Power Output(kW)	50
Motor Inertia[ $Kg - m^2$ ]	0.0226
Max torque output(N-m)	400
Max motor speed(rpm)	6700

**Table B-5 Battery Specifications**

Battery Type	Lithium Ion
Weight	44
Capacity amp-hours	6.5
Capacity watt-hours	3930
Total cells in series	168
No of packs in parallel	3

## REFERENCES

- [1] S. J. Moura, H. K. Fathy, D. S. Callaway, and J. L. Stein, “A stochastic optimal control approach for power management in plug-in hybrid electric vehicles,” *Proceedings of the 2008 ASME Dynamic Systems and Control Conference, 2008*.
- [2] S.R.Chnek, K.E.Builey. “Regenerative Brvlang System for a hybrid Electric Vehicle”. *Proceeding of the American Control Conference*. Anchorage, AK. 2002, “014, pp.3 129-3134.
- [3] Pierluigi Pisu, Kerem Koprubasi and Giorgio Rizzoni, Fellow, IEEE “Energy Management and Drivability Control Problems for Hybrid Electric Vehicles ” *44th IEEE Conference on Decision and Control, and the European Control Conference 2005* Seville, Spain, December 12-15, 2005
- [4] G. Paganelli, M. Tateno, A. Brahma, G. Rizzoni, and Y. Guezennec “Control development for a hybrid-electric sport-utility vehicle: Strategy implementation and field test results,” in *Proc. American Control Conference*, Arlington, VA, 2001, pp. 5064–5069.
- [5] G. Paganelli, G. Ercole, A. Brahma, Y. Guezennec, and G. Rizzoni, “General supervisory control policy for the energy optimization of charge-sustaining hybrid electric vehicles,” *JSAE Review*, vol. 22, pp. 511–518, 2001.
- [6] P. Pisu, C. Musardo, B. Staccia, and G. Rizzoni. “A Comparative Study of Supervisory Control Strategies for Hybrid Electric Vehicles”. *IMECE 2004*, 13-19 November 2004, Anaheim, CA.

- [7] P. Pisu, G. Rizzoni, and E. Calo'. "Control Strategies for Parallel Hybrid Electric Vehicles". *IFAC'04*, Salerno, Italy, 19-23 April 2004, pp.508-513.
- [8] Carlson, E., P. Kopf, and J. Sinha, *Fuel Cell seminar*. 2005, TIAX LLC: Cambridge MA.
- [9] Lin C., Peng H., Grizzle J.W., Kang J., "Power Management Strategy for a Parallel Hybrid Electric Truck", *IEEE Transactions on Control Systems Technology*, Vol. 11, No. 6, November 2003
- [10] Brahma A., Guezennec Y., Rizzoni G., "Dynamic Optimization of Mechanical/Electrical Power Flow in Parallel Hybrid Electric Vehicles", *Proceedings of the 5th International Symposium in Advanced Vehicle Control*, Ann Arbor, MI, USA, 2000
- [11] Sharer, P. B., Rousseau, A., Karbowski, D., 2008, "Plug-in Hybrid Electric Vehicle Control Strategy: Comparison between EV and Charge-Depleting Options," *SAE Paper 2008-01-0460*, 2008 SAE World Congress.
- [12] Rousseau, A., Pagerit, S., and Gao, D., 2007, "Plug-in HybridElectric Vehicle Control Strategy Parameter Optimization," *Electric Vehicle Symposium-23*, Anaheim, CA.
- [13] C. GOKCE, "Modeling and Simulation of a Series Parallel Hybrid Electrical Vehicle", Master Thesis, Institute of Science andTechnology, Istanbul Technical University, Istanbul 2005.
- [14] Jinming Liu, PhD thesis "Modeling, Configuration And Control Optimization Of Power-Split Hybrid Vehicles", University of Michigan 2007.

- [15] An Adaptive Algorithm For Hybrid Electric Vehicles Energy Management, Technical Paper For Students And Young Engineers- *FISITA WORLD AUTOMOTIVE CONGRESS, BARCELONA 2004* -
- [16] [http://www.cleangreencar.co.nz/info\\_toyota-prius-technical.asp](http://www.cleangreencar.co.nz/info_toyota-prius-technical.asp)
- [17] Zhang, Chen, Vahidi, Ardalan, Li, Xiaopeng, and Essenmacher, Dean, "Role of Trip Information Preview in Fuel Economy of Plug-in Hybrid Vehicles" to appear in *Proceedings of ASME Dynamic Systems and Control Conference, Hollywood, CA, 2009*.
- [18] <http://www.eia.doe.gov/oog/info/gdu/gasdiesel.asp>
- [19] [http://www.eia.doe.gov/cneaf/electricity/epm/epm\\_sum.html](http://www.eia.doe.gov/cneaf/electricity/epm/epm_sum.html)
- [20] Jeffrey Gonder and Tony Markel, National Renewable Energy Laboratory, "Energy Management Strategies for Plug-In Hybrid Electric Vehicles", *SAE TECHNICAL PAPER SERIES 2007-01-0290*
- [21] Phillip B. Sharer, Aymeric Rousseau, Dominik Karbowski and Sylvain Pagerit, Argonne National Laboratory, Plug-in Hybrid Electric Vehicle Control Strategy: Comparison between EV and Charge-Depleting Options, *SAE TECHNICAL PAPER SERIES 2008-01-0460*
- [22] Richard W. Carlson, Michael J. Duoba, Theodore P. Bohn and Anantray D. Vyas, Argonne National Laboratory, Testing and Analysis of Three Plug-in Hybrid Electric Vehicles, *SAE TECHNICAL PAPER SERIES 2007-01-0283*

[23] Pesaran, A.A., Vlahinos, A., and Burch, S.D., "Thermal Performance of EV and HEV Battery Modules and Packs," *Proceedings of the 14th International Electric Vehicle Symposium, Orlando FL, December 15–17, 1997.*