

---

## ORIGINAL RESEARCH

---

# THE INFLUENCE OF THE SKIN FATIGUE, ITS PERSPIRATION AND THE TIME OF STIMULATION IN MEASUREMENT OF THE ACTIVE POINTS ON HUMAN SKIN

Marek Kukučka, Zuzana Krajčušková, Viera Stopjaková, Daniela Ďuračková,  
Andreas Weisz

Institute of Electronics and Photonics  
Faculty of Electrical Engineering and Information Technology, Slovak University of Technology  
Bratislava, Slovak Republic

### **Abstract**

*Our contribution deals with the human skin voltage chart measurement. The human skin has a certain impedance or resistance - it can be relatively easily described and simulated using a substitute electric circuit. But the skin also contains parts with measurably lower impedance and different electric properties – we can show them clearly by measurement of voltage chart. We have concentrated our effort on finding and following measurements of active points on certain part of the skin's surface, to acknowledge their existence and positions through a measuring process. The parameters of the measured voltage chart are influenced by the amplitude, frequency, the shape of the measuring electric signal and the parameters of skin-electrode connection changing in time. We focused our research effort in this paper to measure the influence of the time of external stimulation, irritation and a contact press on skin surface together with the skin fatigue and perspiration effects.*

### **Keywords**

*human skin, impedance, voltage measurement, voltage chart, active point, acupuncture, meridian, press, skin fatigue and perspiration effects*

## **I. Introduction**

The human skin has a certain impedance or resistance; it can be easily described and simulated using a substitute electric circuit. But the skin also contains parts with measurably lower impedance and different electric properties. We can see them clearly by a measurement of voltage map. These small parts on the skin's surface are called active points (acupuncture points) and they are known and have been used in acupuncture centuries ago. For many years a number of authors concentrated their efforts to measure them, to describe them and to learn about new properties of them. They are used in different new diagnostic and therapeutic medical devices nowadays.

## **II. The Electrical Model of Skin**

The characteristic impedance of the skin and its capacity allows us to create an equivalent electric circuit of the human skin. The equivalent model of human skin impedance cannot be completely expressed using a simple passive circuit only because the properties of the skin are nonlinear and alternating in time [1]. Considering our attention to a specific surface area of skin and using larger electrode for measurement, the equivalent capacity of the electrode-skin connection would reach greater capacity than the equivalent capacity of the one of the needle telescopic electrodes connections used in our measuring probe. Using a matrix of 64 these electrodes we obtain a

number of equivalent circuit representations for each of them (the capacity of electrode-skin connections are different in different areas of skin surface). Weather protection of skin, its healthcare and also a general health state of person, a stress and perspiration effects are also different, affecting the capacity and conductivity depending on the material, the square and the position of measuring electrode. We have been using a number of point connections of needle electrodes therefore we have decided for the simplest model for skin impedance interpretation. It is a parallel circuit containing a capacitor and a resistor and a serial resistor (Fig. 1). The parallel connection of the capacitor  $C_p$  and the resistor  $R_p$  in this model represents influence of the skin capacity and the serial resistor  $R_s$  represents the impedance of subcutaneous tissue [2], [3]. For  $0.8 \text{ cm}^2$  dry and clean skin, cleansed by ethanol and water values for resistors and capacitor were established as follows:  $R_s = 2 \text{ k}\Omega$  to  $200 \text{ k}\Omega$ ,  $R_p = 100 \text{ k}\Omega$  to  $500 \text{ k}\Omega$  and  $C_p = 50 \text{ pF}$  to  $1500 \text{ pF}$ .

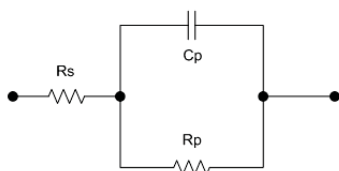

Fig. 1: The equivalent impedance model of the human skin [3].

Using the number of telescopic electrodes with regulated press and constant frequency of driving signal together with the fact we need not the absolute measurement of impedance but the relative, gives us the possibility to use easier impedance model.

### III. Electro-Acupuncture and Physical Structures Called Meridians

Physical structures meridians are objectively measurable, identifiable and describable specific paths in human body. They have special physical features and significance. They contain so called active points which are significant with: skin impedance between these points ( $100\text{-}200 \text{ k}\Omega$ ) and surrounding skin ( $1 \text{ M}\Omega$ ) is different, the electric capacity of these points is greater – within the limits  $0.1$  to  $0.5 \mu\text{F}$ , in comparison with non active points where the capacity reaches only about  $0.01 \mu\text{F}$ . Various authors in their works consider meridians as channels that lead electric charge in extracellular space. The blockage of the flow of these currents leads to a higher concentration of positive or negative charge and a physical manifestation of that can be pain or some disease symptoms. Named here are various qualitative indications on the skin's surface of

significant meridian points, they are interesting from a technical point of view: high electric potential (to  $300 \text{ mV}$ ), high electric capacity ( $0.1$  to  $0.5 \mu\text{F}$ ), low electric resistance, higher skin respiration, higher local temperature, generating of infrasonic waves (from  $2$  to  $15 \text{ Hz}$ ). Some qualitative indications of deeper layer of the skin in significant meridian points: lower level of sensitivity for electric stimulation, higher electric capacity, higher conductivity of isotopic tracers. The measurement of electric parameters of the skin on meridians was described in various literal sources [2], [4]. Meridians have important information, energetic and regulative function in the human organism and are used since centuries in acupuncture prevention, diagnostics and therapy. Disorders in energy flow in the body then manifest in whole body form and state of the organism. The system of active points and meridians contains a multitude of information about the actual state of the organism. The problem is to find the appropriate key to evaluate this information. We have to respect the knowledge and laws of classic acupuncture when solving it [5]. Literature and various web sources describe in a wide range positions and properties of these physical body structures. Electrical stimulation of some specific points and organs has therapeutic effects as well [6]. Because of accessibility and position we have chosen for our measurements *Large Intestine Meridian (Li)*.

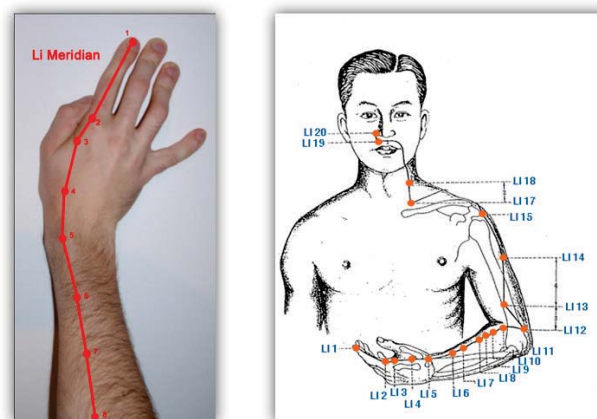

Fig. 2: Large intestine meridian path (Li Meridian).

### IV. Experimental Measuring Device

The basic construction element of the designed and realized measuring device is a processor ATmega16 (Fig. 3.). The processor contains one serial port, eight 10-bit A/D converters and one SPI - Serial Peripheral Interface. For the controlled connection of measuring electrodes multiplexers DG406 were used. The device also contains a modified version of a peak detector. In addition, the device was extended by DDS - Direct

Digital Synthesis AD9833 which is controlled via a SPI bus by a microprocessor [8]. The communication with the PC covers the module DLP-USB-232M which serves as a converter of the USB interface to UART - Universal Asynchronous Receiver/Transmitter. This module and the connected computer are separated from the measuring device by a two channel insulator ADUM1201, because of the safety of the patient. Supplying the device from accumulators is the way how to protect the human operator or the measured object from potential electric injury. Our measurement was realized using needle electrodes [7], [8]. There are 64 electrodes placed into a 8x8 matrix on an isolative holding construction. The distance of needle peaks is 2.5 mm. Each of the electrodes is created by a brass needle located in a cavity shell with a nib which allows fitting each of the electrodes to the surface of the human body and makes the contact. All the electrodes measure the change of voltage with regard to a reference electrode [9] - a drop of voltage induced by driving measuring electrical current from generator of the device, flowing through the unknown skin or body impedance. Our measuring device is allowed to apply maximally 5 V driving voltage. As the reference electrode is used an electrode with larger conductive contact area, for example an ECG clip electrode placed on the chosen suitable position on body i.e. wrist of the hand or the inner ankle area on leg.

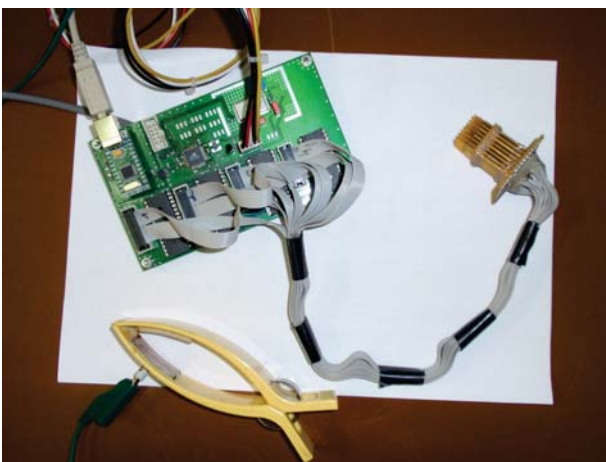
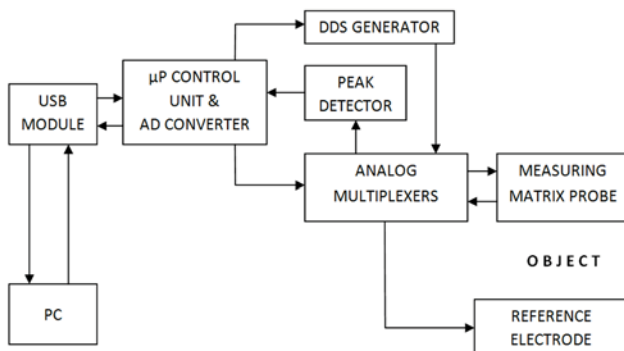

Fig. 3: Block diagram and realized measuring device with connected matrix probe and reference electrode.

## V. Searching for Active Point Position

During the measurement process on the large intestine meridian we found a point which showed a significant change in comparison with previous measurements. It was the active point No.4 on the large intestine LI meridian (Fig. 2., left side) [10]. The point was measured repeatedly, each measurement was performed in a different time and all the measurements proved the existence of that active point (see Fig. 4).

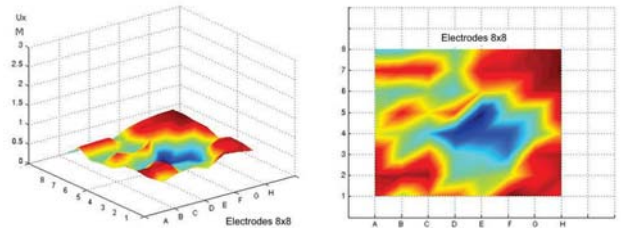

Fig. 4: Voltage chart measured on position of active point No.4 on Li meridian in 3D visualization and 2D visualization.

## VI. The Influence of the Skin Fatigue, its Perspiration and the Time of Stimulation on the Voltage Map Measurement

During our previous research in area of voltage-impedance map on skin measurement (from [10]) we considered, measured and analyzed the influence of the frequency on the voltage map measurement [11], the influence of the shape of driving signal and also the influence of the amplitude of driving signal on the voltage map measurement [12]. After these previous interesting measurements we focused our effort to find out the influence of the skin fatigue, its perspiration and the time of stimulation in measurement of the active points on human skin. The effect of skin fatigue is caused especially because of the long time stimulation of certain skin area by the measuring mechanical probe or its individual electrodes, its weight and press on skin surface. The effect of skin perspiration depends on outer conditions, temperature, humidity of air in laboratory but on health and personal conditions of measured subject as well. Undoubtedly a construction of the measuring probe is also essential. A possibility of the air flow among the contact electrodes of the probe and the ratio of the touching metal area and free separating area of measuring electrodes are significant and reduce the perspiration effect under the measuring probe.

Authors [1] and [4] have chosen two skin areas to unfold the influence of the external pressure on skin during the measurement. First was measuring position on the skin on acupuncture point and second one was

neutral skin area. They performed measurements on these two points (skin areas), trying to explore the change of the skin impedance of these points in relation with the change of the electrode pressure on the skin. Changing the pressure of electrode on the skin in acupuncture point area did not affect the change of its impedance significantly. The impedance of acupuncture point was relatively low, it was  $70\text{ k}\Omega - 80\text{ k}\Omega$ . The impedance of non-acupuncture point changed more significantly in accordance with external pressure. The higher external pressure on skin, the lower value of measured impedance was expected and measured. Changing the external pressure on skin 5 times, measured impedance lowered to a half value. Skin impedance  $1000\text{ k}\Omega$  measured during the pressure induced by weight of  $25\text{ g}$  lowered to  $530\text{ k}\Omega$  using weight  $250\text{ g}$ . Graphical presentation of the whole measurement we can see on Fig. 5.

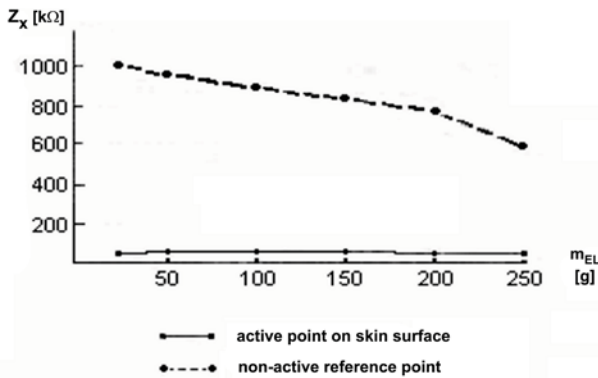

Fig. 5: A change of skin impedance in relation with the external weight pressing on electrode [1].

Authors [1] and [4] also realized measurements to see influence of the duration of measurement process on the measuring signal (el. current) amplitude, with the measuring electrode continuously touching the skin area. We can see the progress of the gradual change of skin impedance in time measured by authors on Fig. 6. via the current change.

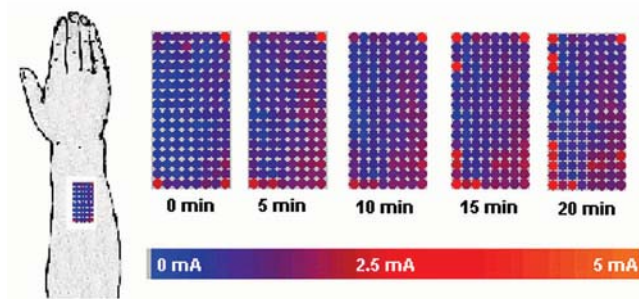

Fig. 6: A change of skin impedance characterized by the flowing el. current in relation with time of external stimulation pressure on electrode [1].

We performed three similar measurements in sequence of time. We placed measuring probe on position of acupuncture point on hand - LI4 (Fig. 4), then measured and recorded values of voltage map of this active point. Measured voltage chart we can see in 3D visualization on Fig. 7.

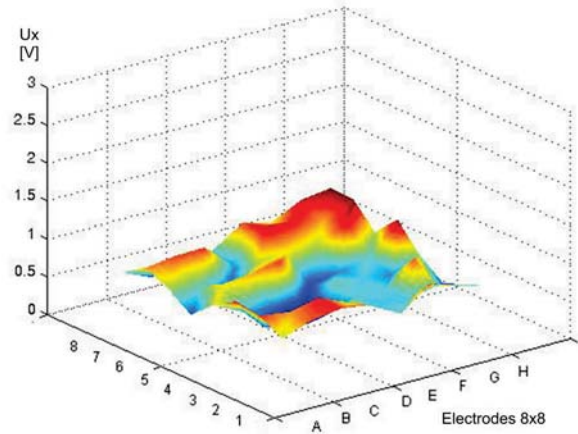

Fig. 7: Voltage chart measured on position of active point No.4 on Li meridian in 3D visualization, at the beginning of time period  $t=0$  minutes.

A table of voltage values for all the 64 probe electrodes (sequenced in rows from 1 to 8 and columns from A to H) was measured and recorded. Measured voltages  $U_x$  (on particular electrodes of the probe) for time  $t=0$  minutes we see described in Tab. I.

Tab. I: Table of measured voltages  $U_x$  on electrodes, at the beginning of measurement, time  $t=0$  minutes (8x8 electrodes in matrix, in rows and columns).

$U_x$ [V]	A	B	C	D	E	F	G	H
1	0,811	0,952	0,996	0,942	0,723	1,011	0,879	0,776
2	0,982	0,913	1,006	0,830	0,669	0,669	0,742	0,654
3	1,035	0,571	0,459	0,523	0,679	0,684	0,962	0,532
4	0,840	0,649	0,581	0,454	0,723	0,674	0,615	0,752
5	0,576	0,864	0,903	0,977	0,547	0,620	0,703	1,089
6	0,791	0,723	0,581	0,801	0,850	0,781	1,030	0,796
7	0,918	0,972	0,977	0,620	1,040	1,006	0,903	1,089
8	0,728	0,552	0,703	0,698	0,957	0,845	1,040	1,099

Then measuring probe remained on the same position of acupuncture point for 15 minutes. The pressure of probe on skin was also constant and the hand position on the table was still and stable. Then we measured and recorded values of voltage map on this active point again. Measured voltage chart after 15 minutes time delay we can see in 3D visualization on Fig. 8. There is visible a gradual change in dynamic range of measured voltages, but the area of active point is still pretty recognizable.



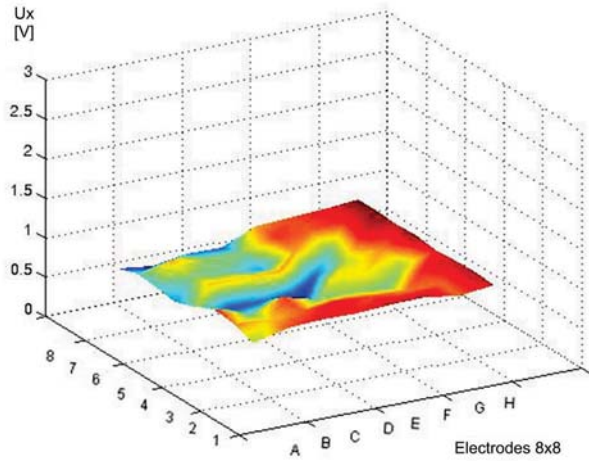

Fig. 8: Voltage chart measured on position of active point No.4 on Li meridian in 3D visualization, in the middle of time period, in  $t=15$  minutes.

A table of voltage values for all the 64 probe electrodes was measured and recorded. Measured voltages  $U_x$  (on particular electrodes of the probe) for time  $t=15$  minutes we can see described in Tab. II.

Tab. II: Table of measured voltages  $U_x$  on electrodes, in the middle of measurement, time  $t=15$  minutes (8x8 electrodes in matrix, in rows and columns).

$U_x$ [V]	A	B	C	D	E	F	G	H
1	0,938	1,030	1,055	1,045	1,084	1,089	1,021	1,074
2	1,011	0,986	1,025	1,055	1,030	1,016	1,021	1,089
3	1,050	0,908	1,035	0,918	0,928	0,913	1,045	1,079
4	0,928	0,811	0,835	0,762	0,972	0,982	0,938	1,060
5	0,845	0,991	0,986	1,001	0,825	0,952	1,011	1,099
6	0,889	0,923	0,908	0,850	1,001	0,908	1,064	1,079
7	0,898	0,996	0,928	0,923	1,040	1,025	1,045	1,104
8	0,811	0,757	0,840	0,825	1,001	1,030	1,055	1,104

Then a measuring probe remained on the same position of acupuncture point for the next 15 minutes period. The pressure of probe on skin and the hand position on the table were constant. After that period we measured and recorded values of voltage map on this active point once more time. Measured voltage chart after 30 minutes time delay (from the beginning of the measurement) we can see in 3D visualization on Fig. 9.

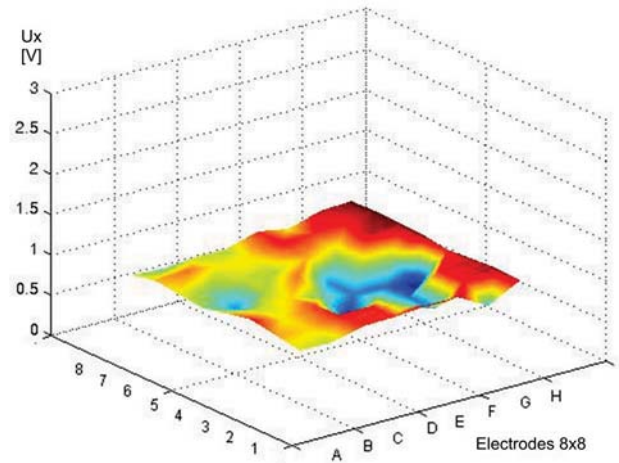

Fig. 9: Voltage chart measured on position of active point No.4 on Li meridian in 3D visualization, at the end of time period, in  $t=30$  minutes.

A table of voltage values for all the 64 probe electrodes was measured and recorded also for the third measurement. Measured voltages  $U_x$  (on particular electrodes of the probe) for time  $t=30$  minutes we can see described in Tab. III.

Tab. III: Table of measured voltages  $U_x$  on electrodes, at the end of measurement, time  $t=30$  minutes (8x8 electrodes in matrix, in rows and columns).

$U_x$ [V]	A	B	C	D	E	F	G	H
1	0,938	0,923	1,030	1,035	1,074	1,084	0,859	1,069
2	0,986	0,967	1,040	1,035	0,928	0,806	1,045	1,089
3	1,045	0,957	1,025	0,757	0,894	0,801	1,050	1,074
4	0,986	0,933	0,967	0,884	0,801	0,796	0,708	1,045
5	0,908	0,811	0,923	1,006	0,811	0,908	0,918	1,089
6	0,947	0,898	0,933	0,923	0,982	0,921	1,074	1,099
7	0,982	1,006	0,952	0,962	1,045	1,030	1,035	1,104
8	0,918	0,889	0,933	0,923	1,030	0,957	1,069	1,104

For easier evaluation of the result of these measurements (graphically and in tabular form described above), considering the achieved voltage scale and dynamic range of values, were calculated mean values of the voltage  $U_{x_s}$  for every measured time step (described in Tab. IV.).

Tab. VI: Table of mean values of the voltage  $U_{xs}$  for the time period of skin excitation by the probe during the time of measurement.

Measurement	1-st.	2-nd.	3-rd.
t [min]	0	15	30
$U_{xs}$ [V]	0,797	0,975	0,964

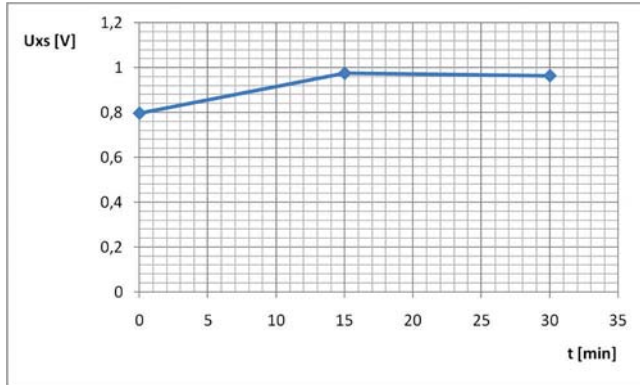

Fig. 10: The relation between measured mean amplitude of voltage on skin  $U_{xs}$  and the time period of skin excitation by the probe during measurement.

Considering the graphical and tabular results, evaluating the mean amplitude of voltage on skin  $U_{xs}$  during the measured time period of skin excitation, we can see that our measurements did not prove such significant impedance fall on measured area of skin surface than in previous measurements of authors [1], [4]. It was because not such prevailing perspiration effect in our measurements than in their case. We have been using a different measuring device with different measuring electrode probe construction. Our measurement was rather like a measurement on the active point on skin area, of the mentioned authors, because our measuring probe achieved an active point, in the middle of skin area, and its surrounding non-active skin area on its surroundings. According to these results we can assume that our “airy” construction of probe with telescopic needle electrodes is more suitable for skin parameters measurements where a perspiration effect could significantly deform achieved results. Our measurements were less influenced by perspiration and skin fatigue effect and more stable.

All the measurements considering the various influences on ability of discovering an active point on the skin were made on a group of enthusiastic volunteers, students and also ourselves. Especially during these measurements was essential to keep the exact position of measuring matrix probe on the selected area of skin for relatively long time term with constant and steady external press on skin. A set of

related measurements considering the amplitude, frequency and shape of the driving signal influence on measured voltage/impedance chart was necessary to perform with the same person, patiently, keeping the position of electrodes on his or her body and changing only the desired parameters of measuring signals, with necessary help of the assisting person.

## VII. Conclusion

Thanks to our automatized measuring device and method we had the opportunity to unfold the position and the shape of certain active points on the human skin surface and measure their voltage maps. We have been continuing in this paper in our previous research of various parameters and conditions influencing process of voltage/impedance map measurements. Our measurements did not prove a significant impedance fall on measured area of skin surface during the period of constant press influence of measuring probe on the skin surface. In time period of 15 minutes and 30 minutes the dynamic range of measured voltages on the skin surface became nearer but the shape of active point with significant impedance drop in its middle area remained pretty distinguishable (see Fig. 8. and Fig. 9.). After the time period of 15 minutes from the beginning of measurement a mean value of measured voltages on electrodes even increased (of 0,178 V i.e. 22 % of the voltage measured in time  $t=0$  minutes) and after next 15 minutes of press excitation mean value of measured voltage lightly decreased (of 0,011 V i.e. 1 % of the voltage measured in time  $t=15$  minutes), as we can see on Fig. 10. We suppose that our results should be possible to generalize to other acupuncture points and meridian paths. Actual problem is the robust construction of the matrix electrode probe. A type of new and perspective flexible probe realized from parts of conductive and insulative rubber is now in development stage. The touch comfort of measurement with a new type of measuring probe would be higher. The effect of perspiration and fatigue of skin during a measurement process would also change, for exact results it would be necessary to verify that new probe experimentally. Different practical diagnostic systems were developed and constructed by various scientific teams of researchers in area of medical electronics. Device of authors [14] has open modular conception (ECG and PPG modules) and has possibility to expand also into similar diagnostic voltage map measurements as ours. In general, our methods and electronic measuring devices used for measuring of 3D voltage charts of human body surface offer a wide space for following practical research and can be useful in medicine, diagnostics and therapeutic process and in education area as well. A detailed description of problem and related issues exceeds the capacity of this

paper and will be a part of our future prepared incoming publications.

## Acknowledgement

The paper was created as a part of a research and education process at the Institute of Electronics and Photonics, FEI SUT in Bratislava, Slovak Republic and is supported by the Grant VEGA 1/0987/12 and VEGA 1/0823/13.

## References

- [1] ZHANG, C. L. Skin resistance vs. body conductivity: On the background of electronic measurement on skin. In: *Subtle Energies and Energy Medicine*, 2003, vol. 14; Part 2, p. 151-174.
- [2] ROSELL, J., COLOMINAS, J., RIU, P., PALLAS-ARENY, R., WEBSTER, G. Skin impedance from 1 Hz to 1 MHz. In: *IEEE Transactions on Biomedical Engineering*, 1988, vol. 35, p. 649-651.
- [3] REILLY, J. P. *Electrical Stimulation and Electropathology*, Cambridge University Press, Cambridge, 1992.
- [4] BECKER, R. O. et al. Electrophysiological correlates of acupuncture points and meridians. In: *Psychoenergetic System*, New York, 1979.
- [5] RUŽIČKA, R. *Acupuncture in Theory and Practice*, Nadas, Praha, 1985.
- [6] PENHAKER, M., HAJOVSKY, R., KOPAS, D. Measurement and Analysis EMC Parameters of Implantable Pacemaker. In: *Journal Przegląd Elektrotechniczny (Electrical Review)*, vol. 87, Iss 5, p. 265-268, 2011.
- [7] ONDREIOV, I. M. *Experimental Impedance Chart Meter of Skin*. Graduation theses, FEI SUT, Bratislava, 2010.
- [8] GOGOLA, D. et al. *Design and Realization of USB Interface for Experimental Scanner of Impedance Chart from Surface of Human Body*, Team project, Bratislava, FEI SUT, 2009.
- [9] TEPLAN, M. Fundamentals of EEG measurement. In: *Measurement Science Review*, 2002, Section 2, vol. 2, p. 1-11.
- [10] KUKUČKA, M., KRAJČUŠKOVÁ, Z. Automated multi-electrode voltage map measurement of active points on skin. In: *Communications: Scientific Letters of the University of Žilina*, 2011, vol. 13, No.1., p. 51-55.
- [11] KUKUČKA, M., KRAJČUŠKOVÁ, Z. The Frequency Influence in Measurement of the Active Points on Human Skin. In: *Trendy v biomedicínském inženýrství: 9. česko-slovenská konference*. Rožnov p. Radhoštěm, 21.-23.9.2011, Ostrava, VŠB - TU Ostrava, 2011, p. 149-153.
- [12] KUKUČKA, M., KRAJČUŠKOVÁ, Z. The Influence of the Shape of Driving Signal in Measurement of the Active Points on Human Skin. In: *Radioelektronika 2012: 22nd International Conference*; Czech Republic, Brno, 17.-18. April 2012, Brno University of Technology, p. 153-156.
- [13] KUKUČKA, M., KRAJČUŠKOVÁ, Z., STOPJAKOVÁ, V., ĎURAČKOVÁ, D. The Influence of the Amplitude of Driving Signal in Measurement of the Active Points on Human Skin. In: *Radioelektronika 2013: Proceedings of 23th Conference Radioelektronika 2013*; Pardubice, Czech republic; 16-17 April 2013. - Pardubice: University of Pardubice, p. 170-175.
- [14] STANKUS, M., PENHAKER, M., KIJONKA, J., GRYGAREK, P. Design and Application of Mobile Embedded Systems for Home Care Applications. In: *Proceedings of 2010 Second International Conference on Computer Engineering and Applications ICCEA 2010*, 19.-21. March 2010, Bali Island, Indonesia, Volume 1NJ. IEEE Conference Publishing Services, pp. 412-416.

marek.kukucka@stuba.sk  
 zuzana.krajcuskova@stuba.sk  
 viera.stopjakova@stuba.sk  
 daniela.durackova@stuba.sk  
 post@weisze.de