

ESTIMATION OF FIRE RESISTANCE BY MEANS OF CALCULATION

Performed for Atypical Exterior Wall of a Woodstructure

Kamil Vargovský^a, Pavol Sedlák^b, Martin Zachar^b

^a Fire engineering, Novozámocká 1350/40, 960 01 Zvolen, Slovakia

^b Faculty of Wood Science and Technology, Technical University in Zvolen, Slovakia

Abstract

The paper describes essential characteristics of a structural system for a wood structure, based on light composite wood stud, designed at Technical University in Zvolen.

The system was reviewed by means of calculation method to prove fire resistance, respecting various relevant current standards of Slovak Republic and in accordance to eurocodes series. The methodology considered wider aspects of evaluation (properties, methods, carbonisation, minimal dimensions, cross sections, thermal field).

Later, simple wall design alternatives were created by modification of inner part of the assembly, in order to examine the influence of the modifications to the total fire resistance of the wall.

Keywords: estimation of fire resistance, calculation method, timber buildings construction, composite wood stud

INTRODUCTION

Development in the building industry and construction brings new designs of external walls, with particular focus on systems using renewable materials – in this case wood. Such walls are subject to proper testing by means of experimental testing and/or by computational methods.

New timber structural system was developed, with light composite wood stud and minimised number of layers within the wall (utility models PUV 219-2011 and PUV 220-2011), at the Department of Woodstructures, Technical University in Zvolen.

The assembly was verified by strength and heat laboratory testing, together with computational methods regarding water vapour transition, environmental impact, production technology, cost analysis and basic structural details of a house.

In order to provide complex view, there was a need for fire resistance evaluation. Fire properties were evaluated by various calculation methods according to relevant Slovak standards, with later option to compare these to experiments.

1 STRUCTURAL SYSTEM

The reviewed system is based on composite stud (Fig. 1), on which there is a board material fixed from interior, to guarantee shear rigidity within the wall. Another board material is fixed to the studs from exterior and therefore closes the cavity filled with insulation (Fig. 2). This board material meets required diffuse water vapour properties.

It is possible to add layers to this basic assembly to modify interior and exterior appearance (Fig. 3). The base assembly itself remains unchanged, as it fulfils insulation, vapour diffuse and load bearing properties.

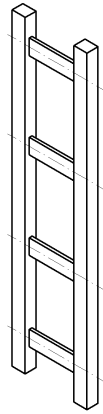

Fig. 1 Composite wood stud

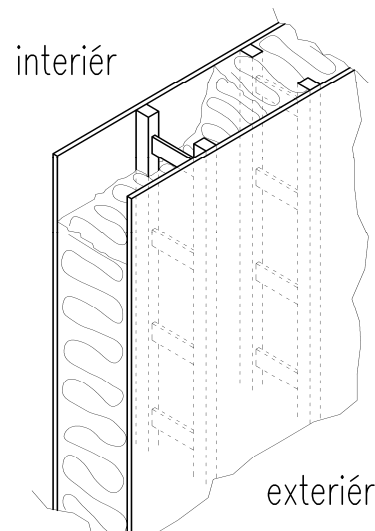

Fig. 2 Basic assembly of the wall

Main advantages of the system:

- Material efficiency
- Utilisation of short-sized timber
- Limiting the layers of the wall
- Simple wall thickness increase by changing only length of the cross-piece within the composite stud
- Design avoiding thermal bridges

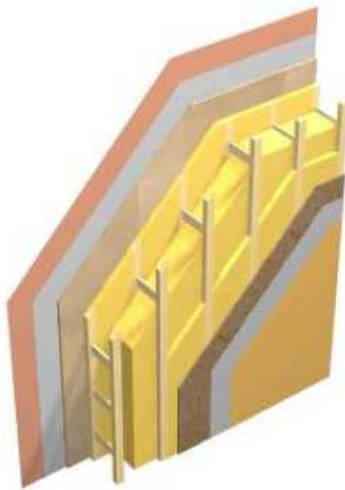

Fig. 3 Optional assembly of the wall



Fig. 4 Experimental shear testing

This structural system was subjected to multiple examinations, in order to find out and refine assumed static and thermal properties (Fig. 4). These were verified by calculations, and later widened to vapour diffuse properties, manufacturing technology, cost analysis, environmental impact analysis.

2 FIRE RESISTANCE DETERMINATION

2.1 Fire resistance determination methods – calculation and evaluation of critical phases of fire resistance

Fire resistance of a building structure is determined (§ 8 promulgation MV SR no. 94/2004 statute):

- on the basis of initial type testing (act no. 90/1998 statute about building products as amended)
- by calculation according to technical standards (in cases where it is possible to express all the relevant factors by calculation , for example under the so-called „Eurocodes for the design of constructions to the effects of fire “)
- by test and calculation (in those cases where the examination is not possible to express and show all the relevant factors affecting the fire resistance test of a building construction)

The decisive factors:

All the important building-physical properties, thermal and mechanical parameters depending on the temperature, at which the known dimensions and for the construction element (structure) allow simplifying the determination of fire resistance.

Reviewed building construction is designed to:

- effects of mechanical loading at normal ambient temperature according to Eurocodes,
- the various factors in the tables for each building element,
- the temperature curve,
- to determine the fire resistance of a structural element.

2.2 Selection of the wall assemblies for the evaluation

There were total 5 assemblies selected (Fig. 5 to 9).

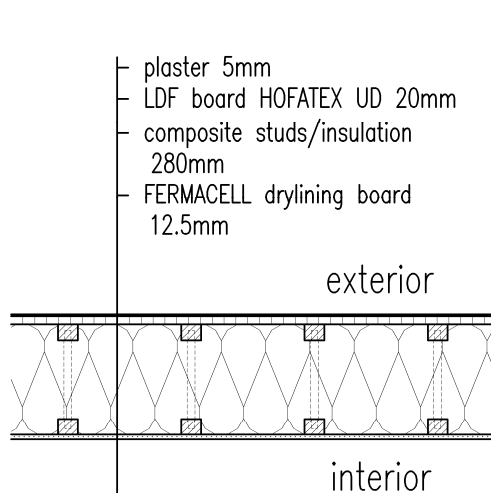

Fig. 5 Assembly 1A, 1B, 1C

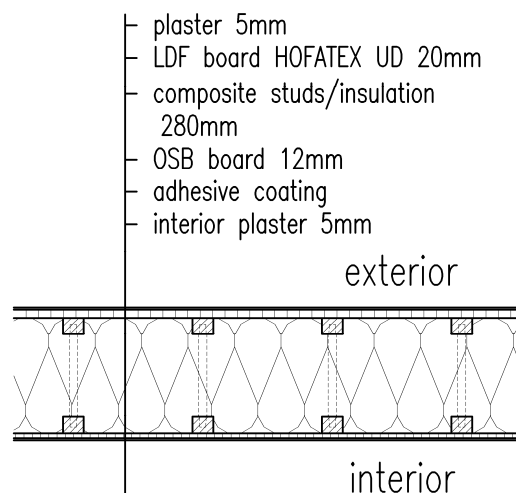

Fig. 6 Assembly 2A, 2B, 2C

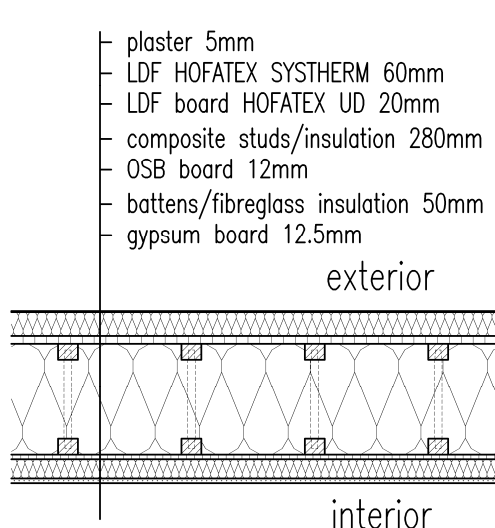

Fig. 7 Assembly 3A, 3B, 3C

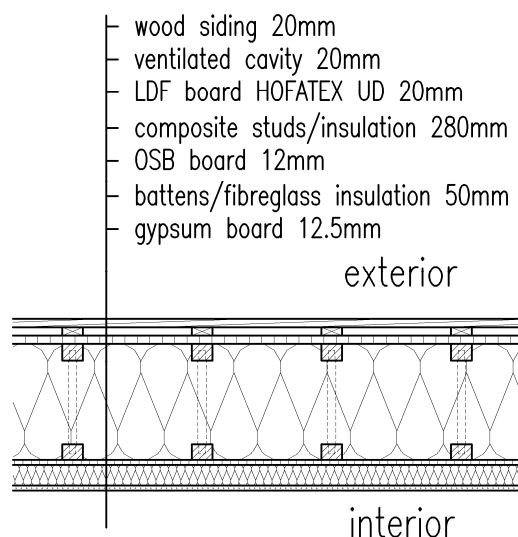

Fig. 8 Assembly 4A, 4B, 4C

For each assembly, there were three options considered:

- A. with insulation Isover DOMO (12 kg/m^3 , $REI_{\max} = 15\text{min}$)
- B. with insulation Isover UNIROL PROFI (23.5 kg/m^3 , $REI_{\max} = 40\text{min}$)
- C. with cellulose insulation CLIMATIZER PLUS (50 kg/m^3 , $REI_{\max} = 60\text{min}$)

Fifth assembly represented typical structure of a timberframe house wall, and was shown to compare to the above structural system (Fig. 5 to 8).

For all of the assemblies, load to a single stud is set to 1.2kN - that means to one part of the composite stud with cross-section 50x40mm. The height of the wall is assumed to be 2750 mm.

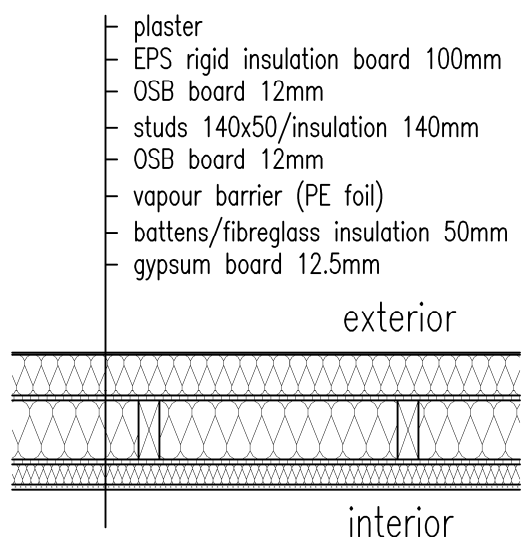

Fig. 9 Assembly 5A, 5B, 5C

2.3 Material properties

Density of the mineral fibre insulation between load bearing studs has to be as follows, according to fire resistance R requirements (EN 1995 – 1 – 2):

- response type reaction to fire tests A1 for assemblies required R 60 -min. density 50 kg/m^3
- response type reaction to fire tests A1 for assemblies required R 60 -min. density 85 kg/m^3
- response type reaction to fire tests A1 for assemblies required R 45 -min. density 30 kg/m^3
- response type reaction to fire tests A1 for assemblies required R 30 -min. density 20 kg/m^3
- response type reaction to fire tests A1 for assemblies required R 15 -min. density 12 kg/m^3

Density of a fibre material forming fire protection external envelope (e.g. thermal facade Hofatex) has to be min. 210 kg/m^3 for 50 mm thickness and fire resistance W 60 (i → o).

2.3 Modification of the assemblies to improve fire resistance

To improve the assemblies, following simple modifications were performed:

- in assembly 1C, thickness of the drylining board Fermacell was increased to 15mm (assembly 1C1) and to 18mm (assembly 1C2)
- in assembly 2C, thickness of the OSB board was increased to 15mm (assembly 2C1)

3 RESULTS

3.1 Fire resistance of the proposed walls

There were several values calculated and evaluated (fire resistance at 100% cross-section utilisation, fire resistance at max. load of a stud to 3kN, depth of carbonisation, keeping minimal dimensions of boards and studs, corruption time of board material), for each assembly. For simplicity, there are only fire resistance values shown, at 100% cross-section utilisation, in order to show and compare the most negative state. This was evaluated as load bearing timberframe external wall - exposure from interior (by STN EN 1991 – 1 – 2).

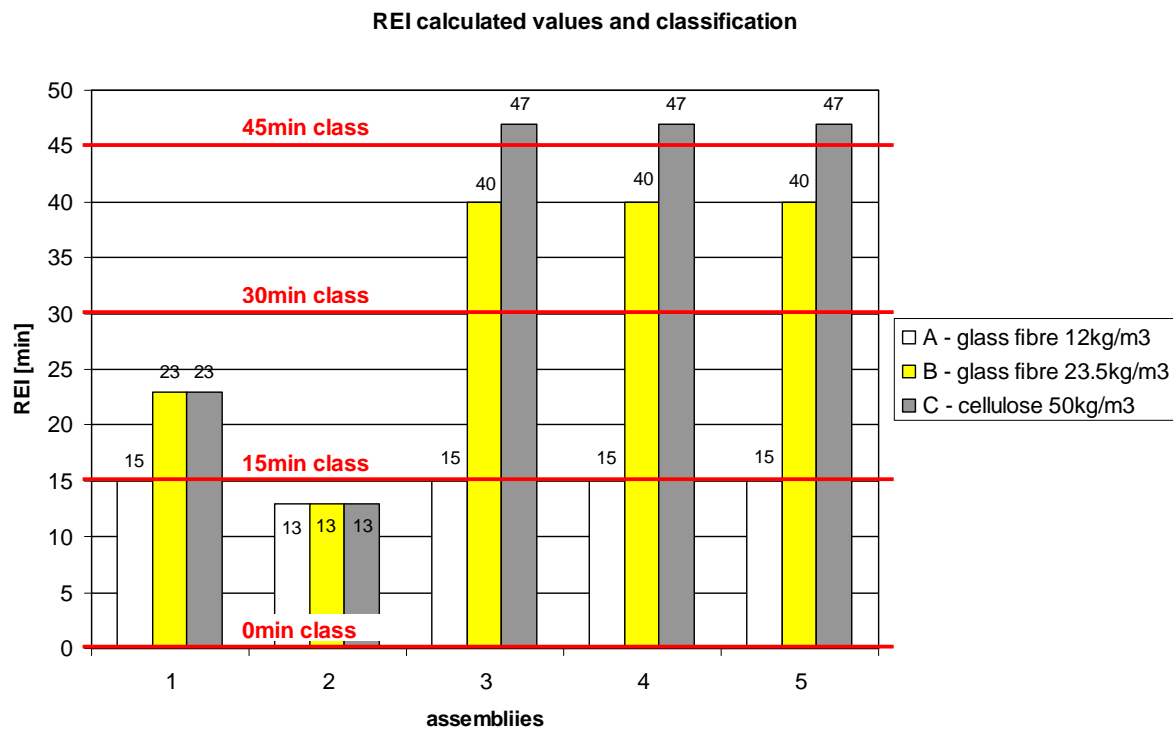

Fig. 10 Calculated values of the fire resistance and the classification according to EN 13501-2

Fig. 10 shows importance of interior layers during internal fire. Thus, fire resistance is basically the same for different structures (composite studs, typical timber stud) while having equal interior layers with fire properties – in this case closed space (usually for wiring, piping, etc) filled with insulation.

Using solely OSB board with plaster from interior proved to be absolutely inappropriate, as 2A, 2B and 2C assembly classification was 0min.

3.2 Effect of the assemblies modification to the fire resistance

It is possible to say, that even simple modification (increasing thickness of the shear-bearing board) can bring an assembly to a higher class of fire resistance (Fig. 11).

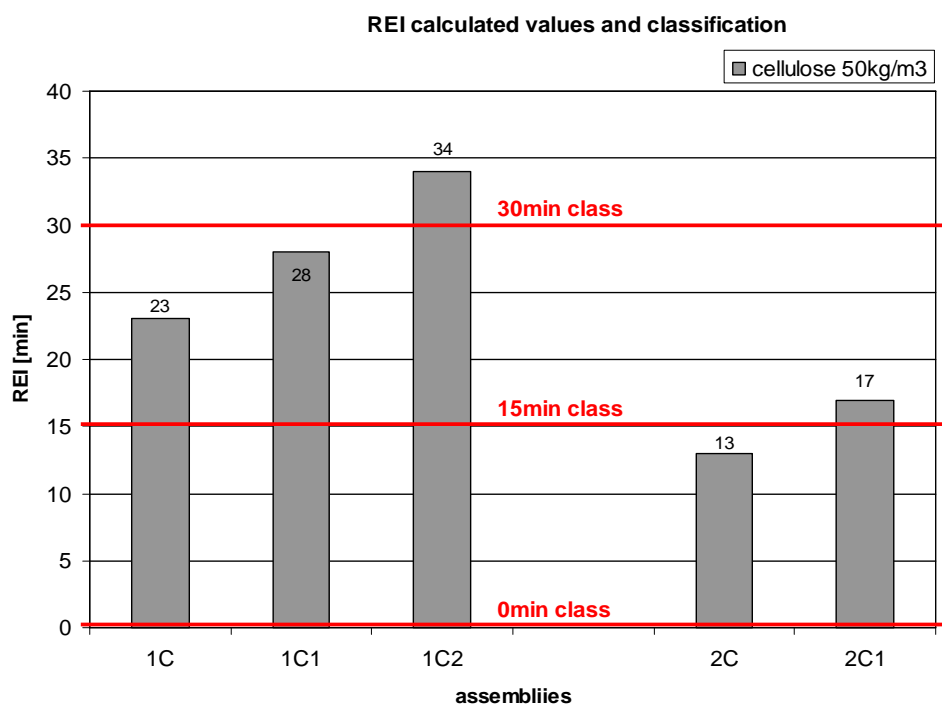

Fig.11 Calculated values of the fire resistance and the classification according to EN 13501-2

SUMMARY

The purpose of the assembly variation and modification was to evaluate fire protection properties, for alternatives of the atypical wood-based external wall. This information is essential at the very early stage of a design process, as appropriate selection of particular materials has to be performed, according to total fire resistance requirements.

REFERENCES

- Decree no. 94 of the Ministry of Interior of the Slovak Republic No. 94/2004 Z. z. – Technical requirements for the fire safety by building and using the buildings.
- EN 13501-2, Fire classification of construction products and building elements- Part 2: Classification using data from fire resistance tests, excluding ventilation services.
- EN 1990, Eurocode: Basis of structural design (E), including Attachment A1: Buildings(S)
- EN 1991 – 1 – 2, Eurocode 1: Actions on structures -Part 1 -2: General actions –Actions on structures exposed to fire.
- EN 1995 – 1 – 2, Eurocode 5: Design of timber structures. Part 1 -2: General. Structural fire design.
- F. Wald et al.: Calculation Fire resistance of buildings constructions, ČVUT Praha 2/2005. ISBN 80-01-03157-8.
- Ed.: Wald F. et al.: Design of construction the Fire influence according to EN, ČVUT Praha 2/2007. ISBN 978-80-01-03580-1.
- Karpaš J., Directives for calculation the Fire resistance of constructions, VÚPS Praha No. 15/84.
- Kuplík V., Buildings constructions from Fire view, Grada Publishing, a.s., Praha 2006, ISBN 80-247-1329-2.