

NUMERICAL MODELLING OF THE BEHAVIOUR OF PROTECTED AND UNPROTECTED WOODEN MEMBERS UNDER FIRE

Magdaléna Dufková^a, Petr Kuklík^a

^a Czech Technical University in Prague, Faculty of Civil Engineering, Department of Steel and Timber Structures, Czech Republic

Abstract

Sufficient knowledge of the behaviour of wood under fire is necessary for the most effective, the most economical, but still safe design of timber structures. The subsequent numerical modelling leads to new computational methods with higher accuracy. This paper is focused on protected and unprotected wooden members, on the contribution of wooden constructions to fire resistance using calcium-silicate boards. On the basis of the fire test results, the comparison of the fire test results with a numerical model in ANSYS was carried out.

Keywords: wood, fire resistance, contribution to fire resistance, protected member, unprotected member

INTRODUCTION

For elements which are protected by the fire shell, the beginning of charring is moved till the time t_{ch} . The charring of a timber element can occur before the deformation of the fire protection but with a lower speed than specified in Eurocode 5 (EN 1995-1-2). Using the testing method (EN 13381-7), a fire test was performed to determine the contribution to fire resistance. In Figure 1, there is a protected member and the location of thermocouples. The location of thermocouples in an unprotected member is the same.

The test standard specifies a test method for determining the contribution of fire protection systems to the fire resistance of structural timber members. Based on this standard, the ability of the fire protection system to delay the temperature rise throughout the timber member, to maintain coherence and a link to the timber member and to provide data of the thermal characteristics of the fire protection system is determined, during its exposition to the load according to the standard temperature/time curve. This test procedure is also applicable to timber structural members incorporating insulating materials between the timber members.

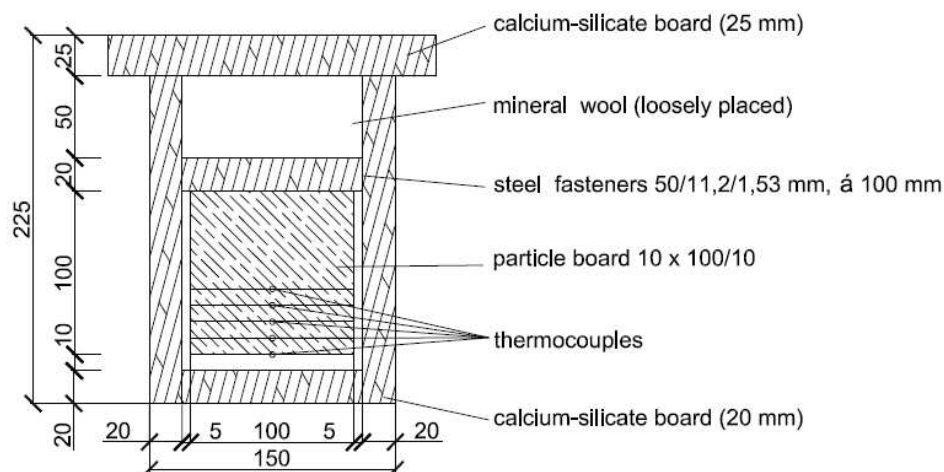

Fig. 1 Protected member and the location of thermocouples

1 FIRE TEST

The assessment and the numerical model based on the fire test of a calcium-silicate board were carried out. The results of the fire test were provided by the Promat, s.r.o. company. In the test furnace, there were specimens with a calcium-silicate board and specimens without a lining. The total dimensions of the board (a specimen without the lining) were 2 000 x 1 200 x 100 mm and the total dimensions of the beam (a specimen with the lining) were 100 x 100 x 4 500 mm. The test specimen consisted of ten chipboard layers bonded by glue. The thickness of the fire protected board was 20 mm.

2 NUMERICAL ANALYSIS

The timber beam was modelled covered by a calcium-silicate board on three sides and these sides were exposed to the fire. The unprotected timber board was modelled with its exposure to the fire from one side. This 3D model was performed using the ANSYS Workbench programme, solved in thermal analysis (Transient thermal) using a fire of 60 minutes.

Material properties for wood at elevated temperatures were taken from the Eurocode (EN 1995-1-2) and for the calcium-silicate board they were supplied by the manufacturer based on testing. The result of this numerical calculation should provide the time when the temperature of the timber member reaches 300 °C, this is the temperature where timber begins to char. Eurocode 5 provides a very limited range of the time t_{ch} (time of the start of charring of timber) and t_f (failure time of the cladding), based on the determination of these values to arrive at a more accurate calculation of fire resistance.

The timber beam has dimensions identical to the test specimen (100 x 100 mm) and it was covered on three sides with a calcium silicate board, with a thickness 20 mm. The unprotected board was modelled a little smaller than in the real fire test specimen (1 000 x 1 000 mm).

Heat transfer by the construction is calculated using the heat-dependent coefficients according to EN 1991-1 -2. Thermal actions are given by the net heat flux h_{net} [W / m²] to the surface of the member. On the fire exposed surfaces, the net heat flux h_{net} should be determined by considering heat transfer by convection and radiation.

In Figures 2 and 3, there is a comparison between unprotected boards after 30 minutes and 60 minutes with exposure to the fire. The comparison between protected beams after 30 minutes and 60 minutes with exposure to the fire is shows in Figures 4 and 5. The depth of char has black colour in the Figures (temperature is higher than 300 °C).

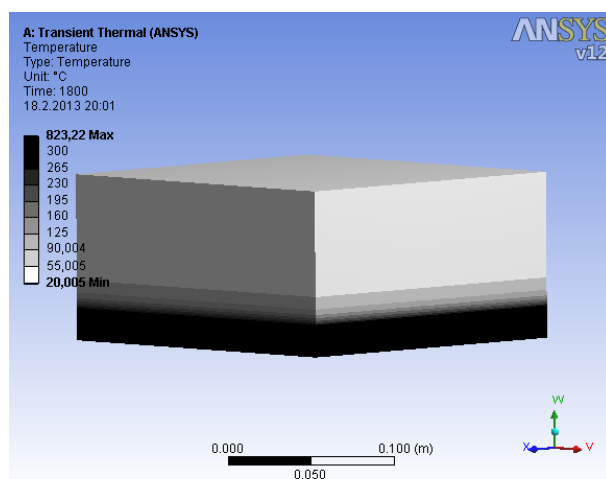

Fig. 2 Unprotected boards after 30 minutes

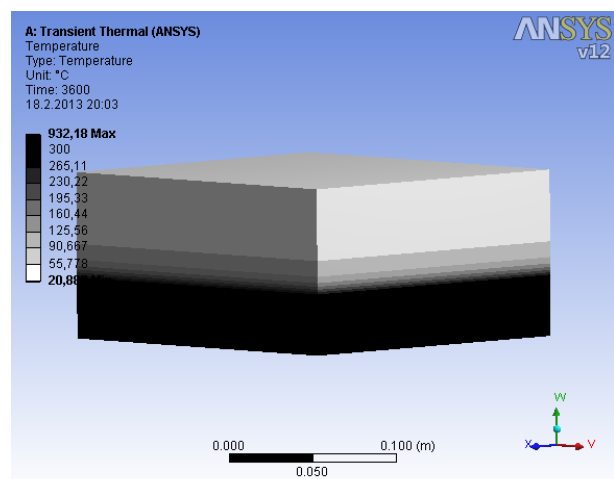

Fig. 3 Unprotected boards after 60 minutes

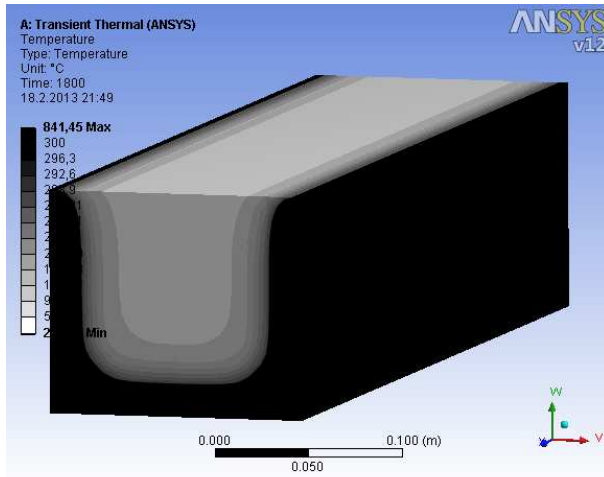

Fig. 4 Protected beam after 30 minutes

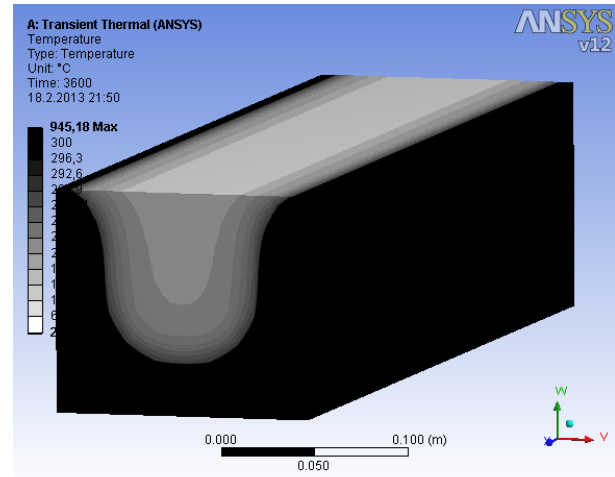

Fig. 5 Protected beam after 60 minutes

3 RESULTS

The results were available from two fire tests of unprotected members (test 1 - thermocouples were disconnected after reaching the temperature of 300 ° C and test 2 - thermocouples measured the temperature until the end of the test). The modelling was performed for 60 minutes. There is shown a very good agreement in comparing the results of the fire tests with numerical analysis in the following graph (Fig. 6).

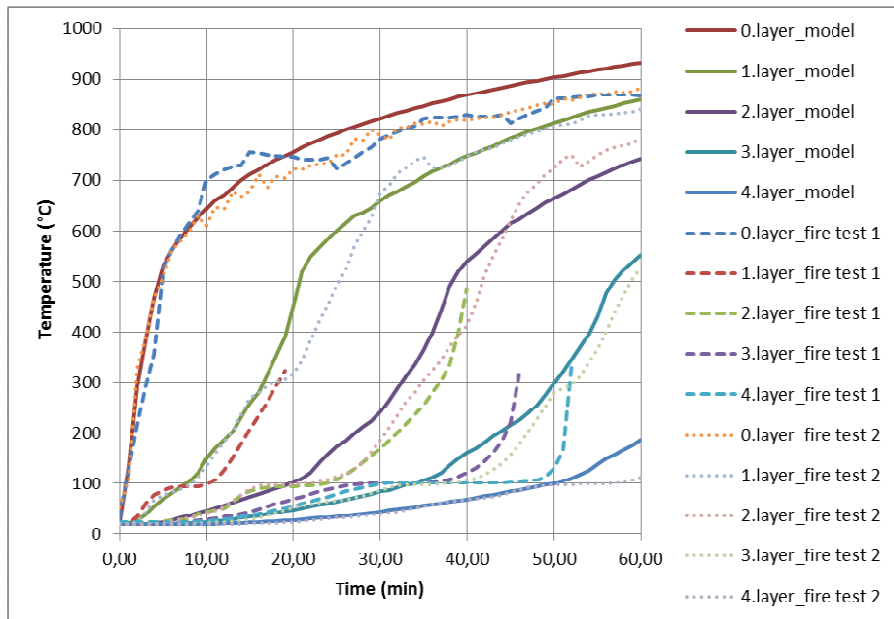

Fig. 6 Temperature in unprotected members obtained from fire tests and from numerical modelling

The protected beam was modelled with a calcium-silicate board 20 mm in thickness used by fire conditions for 60 minutes. In these results, there is also a very good agreement in comparing the results of fire tests with numerical analysis. The fire test result of the protected member was only available from one fire test. There is a problem with well defined mechanical characteristics of the calcium-silicate board, because its behaviour under fire is not predictable very well in comparison with wood.

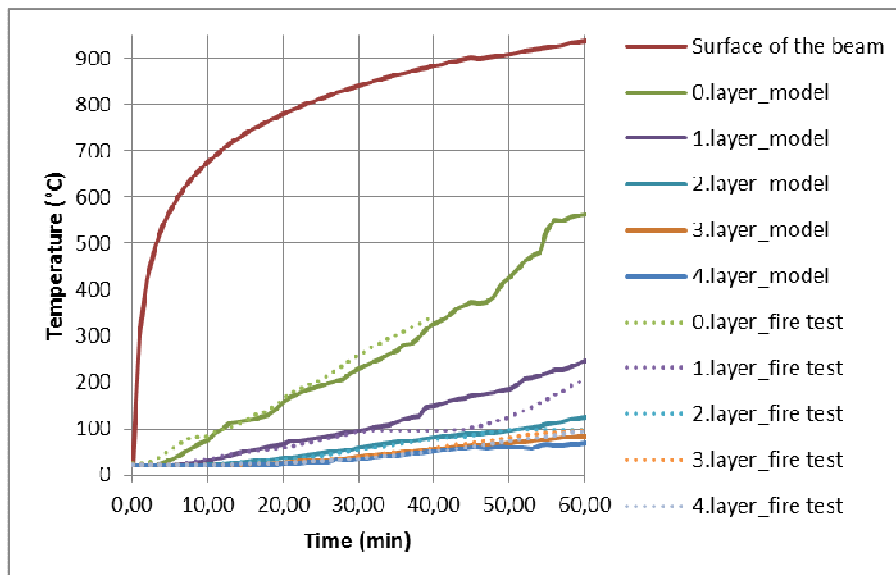

Fig. 6 Temperature in the protected member obtained from fire tests and from numerical modelling

4 SUMMARY AND ACKNOWLEDGMENT

The behaviour of wood under fire is a very predictable phenomenon. Using simplified computational methods can determine the separating and load-bearing function of structures. For a load-bearing bar element it is the parameter R (resistance and stability), for a vertical or horizontal element the design criteria are R, E, I (resistance, integrity, insulation) limits. In many cases, according to Eurocode 5 (part 1-2), it is very difficult or nearly impossible to determine the starting time of charring of the timber element of the fire protection and the failure time of the cladding. In this area, there are still some deficiencies and it is necessary to perform fire tests in order to increase the level of knowledge and to be able to further develop more precise computational methods.

On the basis of numerical analysis, the following was determined:

- with higher density there is a lower growth in temperature;
- with higher heat conductivity there is a higher growth in temperature;
- with higher specific heat there is a lower growth in temperature.

This research is carried out with support from research project - SGS ČVUT, "Příspěvek k požární odolnosti dřevěných konstrukcí pomocí boardového materiálu".

REFERENCES

- ČSN EN 1995–1-2 Eurokód 5: Navrhování dřevěných konstrukcí – Část 1–2: Obecná pravidla – Navrhování konstrukcí na účinky požáru, ČNI, Praha 2006.
- ENV 13381 – 7 Test methods for determining the contribution to the fire resistance of structural members – Part 7: Applied protection to timber members, CEN, 2008.
- ČSN EN 1995–1-2 Eurokód 5: Navrhování dřevěných konstrukcí – Část 1–2: Obecná pravidla – Navrhování konstrukcí na účinky požáru, ČNI, Praha 2006.