

A New Fast Silicon Photomultiplier Photometer

F. Meddi, F. Ambrosino, C. Rossi, R. Nesci, S. Sclavi,
A. Ruggieri, S. Sestito, I. Bruni, R. Gualandi

Abstract

The Crab pulsar is one of the most intensively studied X-ray/optical objects, but up to now only a small number of research groups have based their photometers on SiPM technology. In early February 2011, the Crab pulsar signal was observed with our photometer prototype. With low-cost instrumentation, the results of the analysis are very significant: the processed data acquired on the Crab pulsar gave both a good light curve and a good power spectrum, in comparison with the data analysis results of other more expensive photometer instrumentation.

Keywords: Silicon PhotoMultiplier detector (SiPM), photometer, fast variability, Pulsar.

1 Introduction

Astronomical sources with fast variability are basically of three kinds: pulsars, interactive binaries and pulsating stars. Many of these objects are also X-ray and Gamma-ray sources, and it is of great interest to study them because several orbiting X-ray and Gamma-ray observatories are presently operative. The timescale variabilities range from hours to thousandths of seconds: the amplitude variations in the optical band range from 100 % (Pulsars) down to 0.1 % (O Subdwarfs). For fast time scales, the only detectors available in the optical band used to be classical photomultipliers. In recent times, a new class of detectors, Silicon Photo Multipliers (SiPM), has been developed. Their astronomical use remains to be explored in detail. We have built a prototype of a rapid astronomical photometer, based on SiPM detectors, commercially available from the well-known Hamamatsu company [1]. In this work, we report our first astronomical results.

2 Technical description

Astronomical photometers based on SiPM technology are presently used by very limited numbers of research groups: the OPTIMA team [2] at the Max Planck Institute MPE, and the AQUEYE team [3] at Padua University.

Typical characteristics of these detectors are the short response time (20 ns), segmentation into cells of linear size from 0.025 mm to 0.1 mm, and Photon Detection Efficiency (PDE) up to 75 % at 450 nm. For details see Figure 1, where the code S10362-11-050U refers to the internal sensor present inside each MPPC (Multi Pixel Photon Counter) module that we used. Our system comprises three MPPC modules, by Hamamatsu, with an active area of $1 \times 1 \text{ mm}^2$ and

a pixel size of $50 \times 50 \mu\text{m}^2$. One detector is used to observe the target, a second detector is used for the sky level nearby, and a third one is used to observe a reference star.

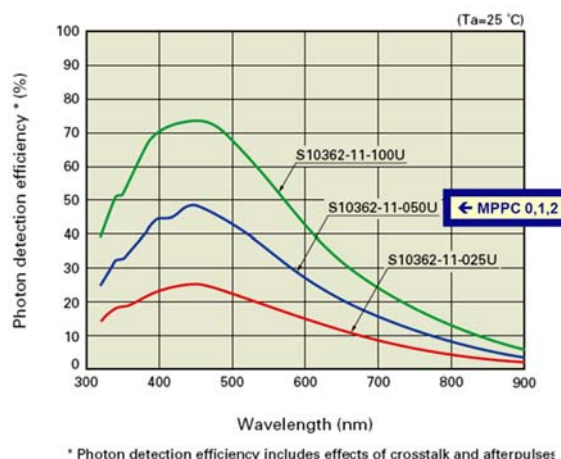

Fig. 1: The blue curve shows the Photon Detection Efficiency of our MPPC modules

The light from the telescope arrives at each detector through a plastic optical fiber (600 μm in diameter). To reduce the electronic noise, the detectors are kept inside a commercial freezer, which cools two of them to about -8.5°C and the third detector to about -6.0°C . The fastest acquisition rate allowed by the software provided with the detectors by Hamamatsu is 1 ms; we have nearly halved the rate to 0.55 ms using a dedicated electronic system named “P3E”, which stands for Pulsar Pulse Period Extractor, developed at the Physics Department of La Sapienza University. The speed limit is at present given by the data recording device (SD card), but we are working to improve this limit. Figure 2 shows a block diagram of our electronic chain.

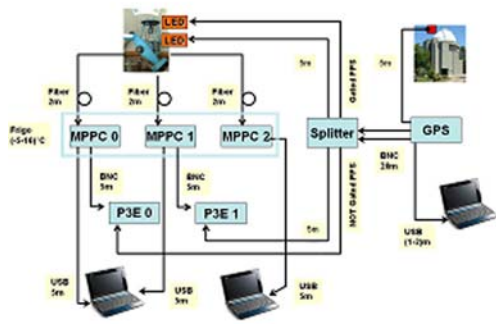

Fig. 2: Block diagram of the electronic chain mounted on the telescope

The Universal Time of the Data Acquisition System is given by a commercial GPS unit, the antenna of which is located outside the dome. The GPS unit provides an information string (coordinates and timing via the serial interface) and also a PPS (Pulse Per Second) signal. The PPS signal arrives either at an I/O (Input/Output) bit of a Microcontroller unit, where it is processed to have the possibility of getting one pulse at the beginning of the measure and another pulse at the end of acquisition (i.e. “Gated PPS”), or it is distributed as original to each P3E unit (i.e. “Not Gated PPS”). The Gated PPS is sent to the system to drive two LEDs to have an optical timing marker. The Not Gated PPS is used by each P3E to start the internal Finite State Machine developed using an FPGA (Field Programmable Gate Array) to count the discriminated signal generated by the MPPC module. The P3E processed data is sent to another Microcontroller unit, which interfaces a mass storage unit via an SD card (FAT 32 formatted) in order to be readable by a PC. The mechanical interface was made partly in our Department and partly at the Loiano Observatory.

We made some preliminary trials both on the Vallinfreda 50 cm Newtonian telescope [4] and on the Loiano 152 cm Cassegrain telescope [5] to check the overall efficiency and linearity of the instrument response with stars of a given magnitude. In Figure 3, the upper line refers to the Loiano telescope and the lower line refers to the Vallinfreda telescope

We selected the Loiano telescope for our photometer, because it is provided with a special focal plane arrangement which allows several instruments to be mounted simultaneously. A simple flip mirror enables them to be fed alternately. Two further separate probes on the focal plane feed the guiding camera and an auxiliary camera. The target is pointed with the main CCD instrument (BFOSC) of the telescope permanently mounted on-axis. The flip mirror can redirect the light of the target to the first of our detectors through an optical fiber, without changing the focus position. The sky signal is recorded by a sec-

ond optical fiber located at a distance of 17 mm from the first one. The third optical fiber is positioned in the place of the auxiliary camera and can look at a reference star using the independent probe on the focal plane. We determined the position of a source on the CCD detector of BFOSC when it is centered on the SiPM sensor, so we can point a source with BFOSC and then flip the mirror to get the signal on the sensor itself.

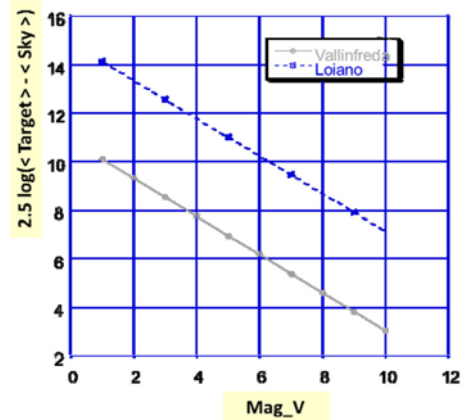

Fig. 3: Magnitude computed by a Pogson’s Law-like (number of detected photons from Target minus Sky Background) as a function of a known magnitude (Mag_V)

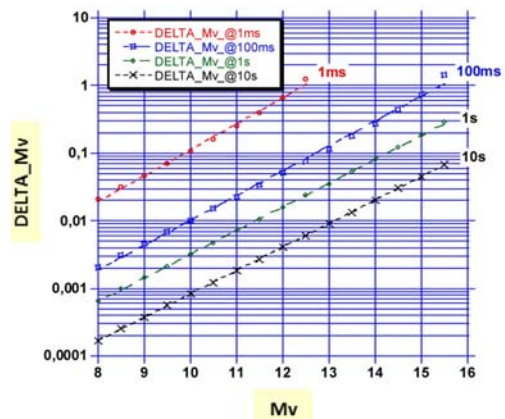

Fig. 4: Magnitude variation sensitivity (DELTA_Mv) as a function of a given magnitude (Mv), for various gate time durations

Faint sources (16 mag) can be observed with 1 ms integration time and with a signal-to-noise ratio (S/N) ~ 1 with this telescope. The calibration of the number of photons detected by our photometer was obtained by comparing the convolution integral of the absolute flux, derived from stars in the Jacoby catalog, respectively, with SiPM PDE and the transmittance of Johnson filters B and V. Figure 4 reports the expected sensitivity in magnitude (DELTA_Mv) as a function of visual magnitude (Mv) varying the MPPC integration gate length from 1ms up to 10 s.

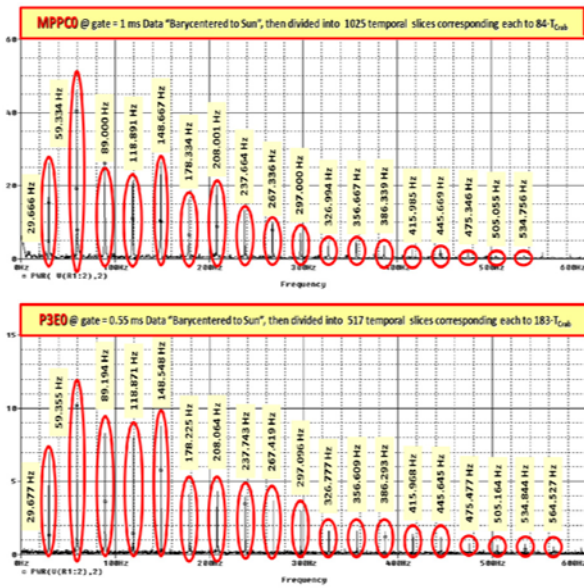

Fig. 5: Power Spectra of the Crab Pulsar signal detected by MPPC0 (upper) and P3E0 (lower)

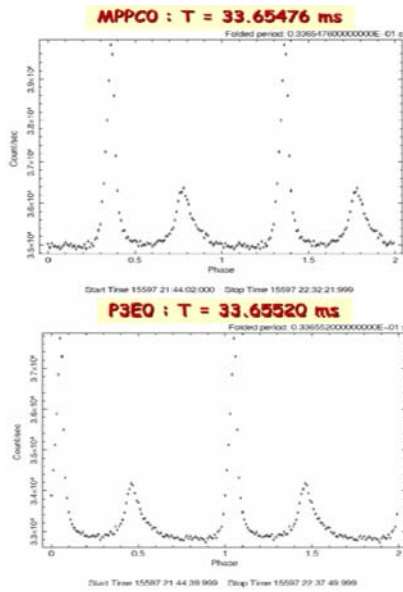

Fig. 6: Crab Pulsar light curves folded by “efold” for MPPC0 (upper) and P3E0 (lower)

3 Observational test: the Crab Pulsar

On February 5, 2011 we observed the Crab Pulsar for 3300 seconds with 0.55 ms (P3E0) and 1 ms (MPPC0) sampling in good photometric conditions (seeing ~ 1.5 arcsec). The Fourier power spectra for both MPPC0 and P3E0 show typical Crab Pulsar characteristics (Figure 5). Refined data analysis was performed using Xronos software from HEASARC [6] with the following steps:

- a) correction for the motion of the Earth to reduce the data to the Sun barycentre with “earth2sun”;
- b) the best fitting period was then searched with “efsearch”, finding a result in agreement (within $3 \mu\text{s}$) with the radio ephemeris from Jodrell Bank ($P = 0.033\,652\,394$ s) [7];
- c) the folded light curve was computed with “efold” and is reported in Figure 6. The flux ratio between the primary and secondary pulse is in fair agreement with the literature (e.g. [8]).

4 Conclusions

Our analysis has demonstrated that our instrumentation can detect the Crab Pulsar signal using a 152 cm Loiano Telescope. Real time (S/N) ~ 1 can be increased by applying corrections (i.e. orbital Earth motion around the Sun) and data manipulations (i.e. integer multiple Crab period temporal slice overlapping). For our MPPC0 and P3E0 detectors, we saw a good Crab Pulsar signal by overlapping $n = 1025$ and $n = 517$ slices obtaining (S/N) ~ 32 and ~ 23 , respectively, at a reasonable data collection duration (~ 55 min.) at the telescope.

References

- [1] <http://www.hamamatsu.com/>
- [2] Kanbach, G., et al.: *SPIE*, **4 841**, 82, 2003.
- [3] Barbieri, C., et al.: *SPIE*, **7 355**, 15, 2009.
- [4] <http://astrowww.phys.uniroma1.it/nesci/vallin.html>
- [5] <http://www.bo.astro.it/loiano/index.htm>
- [6] <http://heasarc.nasa.gov/docs/xanadu/xronos/xronos.html>
- [7] <http://www.jb.man.ac.uk/pulsar/crab.html>
- [8] Lynds, R., et al.: *APJ*, **155**, L121, 1969.

F. Meddi, F. Ambrosino
 C. Rossi, R. Nesci
 S. Scavi
 Dipartimento di Fisica
 Università La Sapienza, Roma

A. Ruggieri, S. Sestito
 INFN – Sez. Roma 1

I. Bruni, R. Gualandi
 INAF – Osservatorio Astrofisico di Bologna