

Original

A Novel Approach to Endoscopic Submucosal Dissection Using Bipolar Current Needle Knife for Colorectal Tumors

Kazuhito Ichikawa¹, Wataru Sano², Yasushi Sano², Mineo Iwatate^{1,2},
Taro Ikumoto^{1,2}, Hiroaki Ikematsu^{1,3}, Yosuke Otake^{1,4}, Yukari Fujimori¹,
Takashi Maruoka^{1,5}, Takahiro Fujimori¹

¹ *Department of Surgical and Molecular Pathology, Dokkyo Medical University School of Medicine, Tochigi, Japan*

² *Sano Hospital, Gastrointestinal Center, Hyogo, Japan*

³ *Division of Digestive Endoscopy and Gastrointestinal Oncology, National Cancer Center Hospital East, Chiba, Japan*

⁴ *Division of Endoscopy, National Cancer Center Hospital, Tokyo, Japan*

⁵ *Maruoka Clinic, Yamagata, Japan*

SUMMARY

Objective : To completely and safely remove a large colorectal lesion in a single fragment, we have developed an endoscopic electrosurgical knife (B-Knife) for a more effective bipolar cutting and coagulation system. The aim of this study was to evaluate the effectiveness and safety of the B-Knife in patients with large colorectal tumors.

Methods : Endoscopic submucosal dissection (ESD) using the B-Knife was performed initially in 3 patients with large colorectal tumors in a pilot study. Subsequently, we examined the clinical outcomes of ESD using the B-Knife in 25 patients with colorectal tumors.

Results : During initial clinical use of the B-Knife, en bloc resection was achieved in all 3 cases, and the mean operating time was 43 minutes. All margins of resected material were histologically free of neoplasia. There were no cases of delayed bleeding or perforation. In a series of 25 ESD cases, which consisted of 8 adenomas, 15 intramucosal carcinomas, one slightly submucosal invasive carcinoma, and one massive submucosal invasive carcinoma, the en bloc resection rate was 84%. The mean operation time was 91.6 minutes and the mean size of resected specimens was 36.4 mm (range : 19–80 mm). Perforations occurred in one (4%) case, but delayed bleeding did not occur in any of the cases. Additional surgery was required for 2 cases (8%).

Conclusions : ESD using the B-Knife is reliable and safe for the complete resection of select large flat lesions in the colorectum.

Key Words : endoscopic electrosurgical knife, endoscopic submucosal dissection (ESD), colorectal tumors

INTRODUCTION

The recent development of a high-resolution video colonoscope has facilitated the identification of large superficially spreading neoplastic lesions, so-called laterally spreading tumor (LST)^{1,2}. Conventional/piece-meal endoscopic mucosal resection (EMR) has been accepted as a standard treatment for these lesions^{3,4}.

Received February 22, 2012 ; accepted May 22, 2012

Reprint requests to : Kazuhito Ichikawa

Department of Surgical and Molecular Pathology, Dokkyo Medical University School of Medicine, Mibu, Shimotsuga, Tochigi, 321-0293, Japan

However, complete removal of these lesions by conventional snare polypectomy is difficult because of their larger size and flat morphology. Incomplete removal and local recurrence are frequently observed after piecemeal EMR^{5,6)}. Furthermore, electrocautery snare resection stimulates cellular proliferation in the residual colorectal tumor⁷⁾, and 17% of locally recurrent tumors after piecemeal polypectomy are cancerous, although the excised specimens are diagnosed as benign adenomas⁶⁾. Moreover, reconstruction of multiple resected specimens is sometimes impossible, thus eliminating the possibility of accurate histopathological assessment⁸⁾. These findings suggest that en bloc resection is required for complete resection. Thus, the use of endoscopic submucosal dissection (ESD) in the colon has been recommended for the treatment of LSTs^{9~13)}. However, the technique is difficult and risk of complications, such as bleeding and perforation, is high in the initial studies^{11,12)}. Recently, colorectal ESD has gradually been carried out in some institutions with favorable results by the development of advanced equipment^{14~26)}. According to the latest reports, en bloc resection and perforation rates are currently 82.8% (range, 61–98.2%) and 4.7% (range, 1.4–8.2%), respectively²⁷⁾.

To completely and safely remove a large lesion in a single fragment, we have developed an endoscopic electrosurgical knife (B-Knife) for a more efficient bipolar cutting and coagulation system. Our preliminary results from a bench study using a swine stomach showed that tissue traumatization was much less with the B-Knife than with a needle knife and monopolar current^{28,29)}. The aim of this study was to evaluate the effectiveness and safety of the B-Knife in patients with large colorectal tumors.

MATERIAL AND METHODS

ESD using B-Knife

To minimize deeper tissue damage due to the (electrical) coagulating and cutting current, an endoscopic device with a needle-shaped knife was developed (B-KnifeTM, Zeon Medical Inc, Tokyo, Japan) (Fig. 1)²⁸⁾. The B-Knife, a bipolar coagulation and cutting system, has a diffusion electrode attached to the tip of its sheath and an active electrode attached to the knife at the end of the sheath. The knife of this device also has

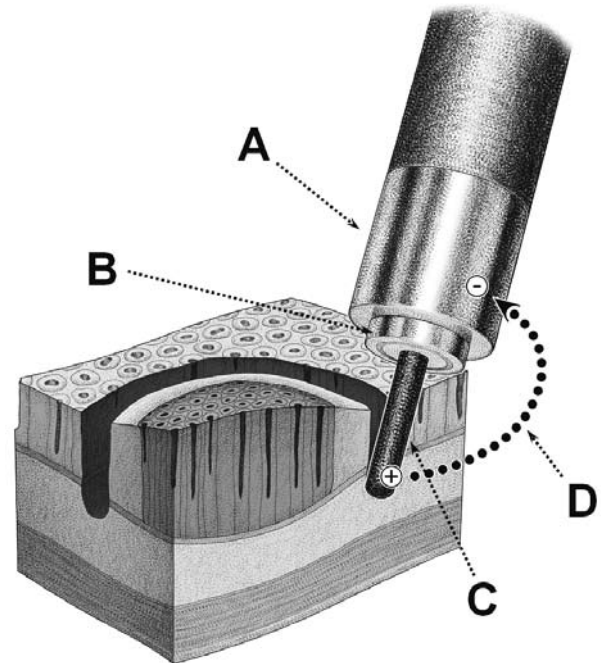

Fig. 1 Design showing the route of high frequency current at the tip of the B-Knife.

- A. Collection electrode of the outer sheath.
- B. Insulation tube.
- C. Discharge electrode of the inner needle core.
- D. High-frequency current for cutting or coagulation.

Fig. 1 : Courtesy of Sano Y (Reproduction of figure that have been published, Sano Y, et al. *Endoscopy* 38, 2006²⁸⁾).

a special resinoid coating which enables the current of electricity per unit area, so-called electric current density. In addition, with a design in which high-frequency electricity flows from the knife to the sheath tip, the amount of high-frequency current sent from the knife tip to the muscle layer is reduced. Local submucosal injection of sodium hyaluronate and/or glycerin, which contained small amounts of indigo carmine and epinephrine, was administered to the patients during the procedure. The electronic instrument was set at 30 W, forced coagulation mode, as previously reported³⁰⁾.

ESD was indicated for large colorectal tumors (> 20 mm) that were expected to present difficulties in an en bloc resection using the conventional EMR technique. However, an endoscopic finding of submucosal massive invasion was considered a contraindication for ESD because of the high risk of lymph node metastasis.

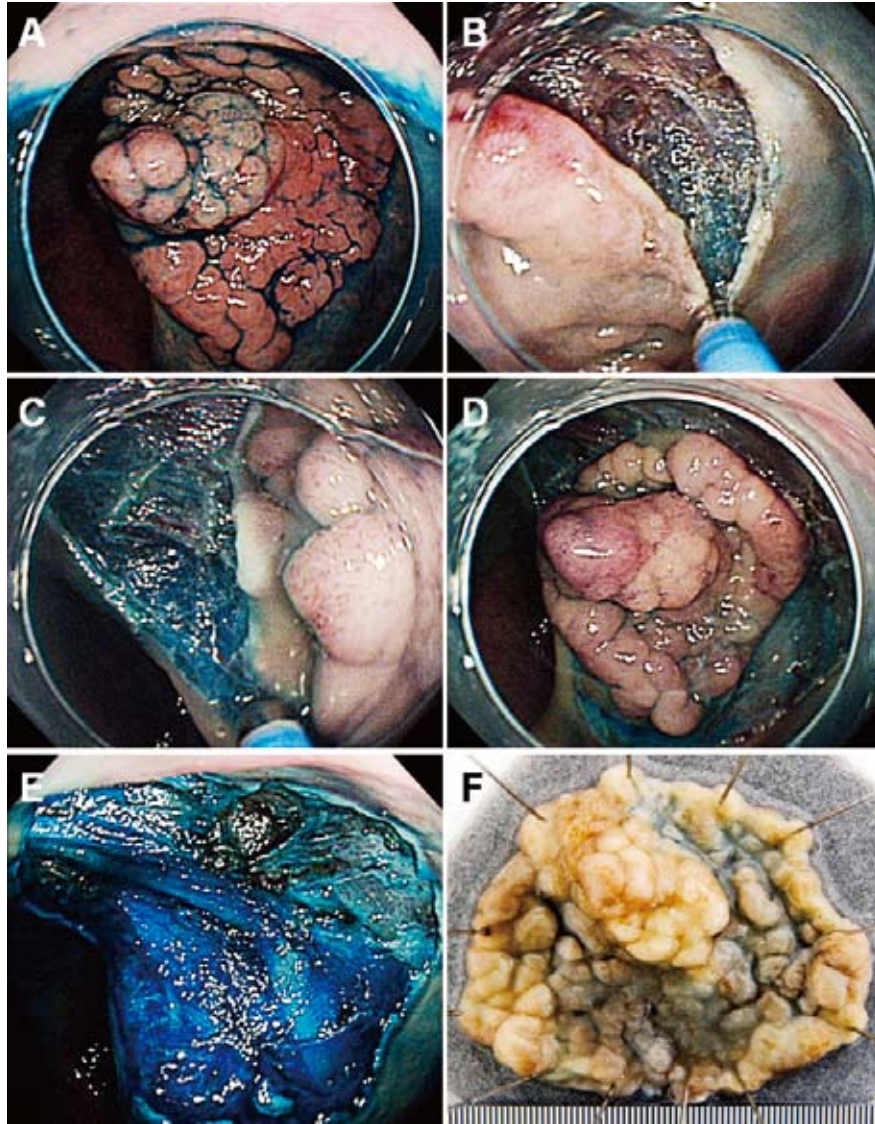

Fig. 2 Endoscopic findings of ESD technique using the B-Knife in case 1.

- A. A rectal lesion after spraying with indigo carmine dye.
- B. Cutting the mucosa around the lesion using the B-Knife after injection into the submucosal layer of glycerin mixed with indigo carmine dye.
- C. The submucosa is dissected immediately after mucosal incision.
- D. The opposite side of the marginal incision and submucosal dissection (ESD) is performed with the B-knife.
- E. En bloc resection is achieved without complications.
- F. The complete resected specimen as a single fragment.

Patients

In the pilot study, ESD using the B-Knife was performed in 3 patients at the National Cancer Center Hospital East, Chiba, Japan. The mean procedure duration and occurrence of complications were evaluated in these initial 3 patients.

After the pilot study, ESD using the B-Knife was performed in 25 patients with colorectal tumor at Sano

Hospital in Hyogo, Japan from September 2006 to October 2008. In this study, we examined the operation time, and en bloc resection, perforation, delayed bleeding, and additional surgery rates.

Clinicopathological data were retrieved from charts and endoscopic and pathology reports. Endoscopic tumor morphology was classified in accordance with the Paris endoscopic classification²⁾. LSTs were catego-



Fig. 3 Histological examination of the resected specimen. Histological examination shows well-differentiated adenocarcinoma with an adenomatous component and a free margin.

ized as granular (LST-G) or non-granular (LST-NG) type¹⁾. Histological diagnosis was carried out according to the Japanese classification of colorectal carcinoma³¹⁾. All ESD specimens were cut at 2 mm intervals to determine the histological type, depth of invasion (intramucosal carcinoma, pM; slightly submucosal invasive carcinoma with depth < 1000 μ m, pSM1; massive submucosal invasive carcinoma with depth \geq 1000 μ m, pSM2), amount of fibrous stroma, invasive growth pattern, invasion of the vessels and margins of clearance.

Follow-up endoscopy was performed at intervals of 3–6 and 15–18 months after ESD to confirm healing of the ulcers by using magnifying chromoendoscopy, and to exclude the presence of residual tumor.

The study protocol was approved by institutional review board at National Cancer Center Hospital East and Sano Hospital. All patients were informed about the risks and benefits of devices used, and provided written informed consent to ESD treatment for large colorectal tumors.

RESULTS

Clinicopathological features of initial three cases

Case 1: A 74-year-old woman was referred for colonoscopy because of a positive fecal occult blood test. The examination showed a 40 mm, large sessile lesion (0-Is type) in the upper rectum. Case 2: A 50-year-old man was referred for detailed evaluation because of bloody stool. Colonoscopy showed a 50 mm, large sessile lesion (0-Is type) in the upper rectum. Case 3: A 46-year-old man was referred for EMR of a large flat elevated lesion, and colonoscopy revealed a

28 mm lesion of LST-NG type in the sigmoid colon.

Clinical outcomes of initial three cases

En bloc resection was achieved in all 3 cases (Fig. 2). The mean operating time was 43 minutes, and the individual operating times were 35, 50, and 45 minutes, respectively in cases 1, 2, and 3. Histopathologic evaluations revealed that the lesions of case 1 and 2 were both well-differentiated intramucosal adenocarcinomas in tubulovillous adenoma (Fig. 3), and that of case 3 was diagnosed as well-differentiated intramucosal adenocarcinoma. All margins were free of neoplasia. In case 2 minor bleeding caused by dissection of the submucosal layer occurred, but it was successfully treated by electrocoagulation. There were no cases of delayed bleeding or perforation, and all patients were discharged within 3 days. Follow-up endoscopy was performed at 3 months in each of the three patients by using magnifying chromoendoscopy, which revealed healed scar tissue with pit pattern type I and no recurrence in all cases.

Clinicopathological features of twenty-five cases

Table 1 summarizes the clinicopathological features of the 25 patients (13 men and 12 women) with colorectal tumors treated by ESD using the B-Knife. The mean age of the patients was 64.4 years (range, 42–83 years). The mean maximum diameter of the lesions was 36.4 mm (range, 19–80 mm). The lesions were located in the rectum in 6 cases, sigmoid colon in 5 cases, transverse colon in 6 cases, ascending colon in 4 cases, and ileocecum in 4 cases. The gross types of lesions included: 11 cases of LST-G; 11 cases of LST-

Table 1 Clinicopathological features of 25 patients with colorectal tumors

Sex (men/women)	13/12
Age, years, mean (range)	64.4 (42-83)
Lesion maximum diameter, mm, mean (range)	36.4 (19-80)
Location, n (%)	6 (24)
Rectum	5 (20)
Sigmoid colon	0 (0)
Descending colon	6 (24)
Transverse colon	4 (16)
Ascending colon	4 (16)
Ileocecum	
Gross type, n (%)	
Laterally spreading tumor (LST)	11 (44)
Granular (LST-G) type	11 (44)
Non-granular (LST-NG) type	3 (12)
0-Is	
Histological diagnosis, n (%)	8 (32)
Adenoma	15 (60)
Carcinoma	1 (4)
pM	1 (4)
pSM1	
pSM2	

pM, intramucosal carcinoma ; pSM1, pathological submucosal invasive carcinoma with depth < 1000 μ m ; pSM2, pathological submucosal invasive carcinoma with depth \geq 1000 μ m.

NG ; 3 cases of 0-Is. Histological examination revealed 8 cases of adenomas, 15 cases of pM carcinomas, one case of pSM1 carcinoma (depth < 500 μ m), and one case of pSM2 carcinoma (depth > 2000 μ m).

Clinical outcomes of twenty-five cases

The outcomes of the ESD are shown in Table 2. The mean operation time was 91.6 minutes. En bloc resection was achieved in 21 of the 25 treated lesions (84 %). Perforation occurred in one case (4%), which was managed by conservative medical treatment after endoscopic closure with clipping. In some cases minor bleeding caused by dissection of the submucosal layer occurred, but it was successfully treated by electrocoagulation. There were no cases of delayed bleeding.

Two cases (8%), a pSM2 carcinoma and a local recurrence, underwent additional surgery after ESD. The former case, which consisted of a lesion located in the sigmoid colon classified as LST-NG type (maximum diameter, 30 mm), well-differentiated adenocarcinoma in adenoma, and pSM2 (depth > 2000 μ m, carcinoma identified at the deep margin) with lymphatic

Table 2 Clinical outcomes of 25 colorectal ESD using the B-Knife

Operation time, min, mean	91.6
En bloc resection, n (%)	21 (84)
Perforation, n (%)	1 (4)
Delayed bleeding, n (%)	0 (0)
Additional surgery, n (%)	2 (8)

invasion, was resected by partial colectomy with lymphadenectomy. Furthermore, the patient underwent adjuvant chemotherapy after surgery because there was metastasis to the lymph node. The other case consisted a lesion situated in the ileocecum, which was classified as LST-G type (maximum diameter, 65 mm), well-differentiated adenocarcinoma in adenoma, and pM, was resected in multiple segments by ESD. At the follow-up endoscopy, the tumor recurred on the ESD scar, which was resected by partial colectomy with lymphadenectomy after additional endoscopic resection. A residual portion of the tumor remained in the colon, but there was absence of metastasis to the lymph node.

DISCUSSION

EMR has been widely accepted as a treatment for flat and larger colorectal lesions. In Japan, en bloc resection, such as ESD using an insulation-tipped (IT) knife, a needle-knife, or a hook-knife, for early gastric cancers has recently been recommended whenever possible to reduce the incidence of residual or recurrent tumors^{13,32~35}. However, ESD was not acceptable as a standard technique for large colorectal mucosal neoplasms, because of its technical difficulty, prolonged procedure duration, higher incidence of complications, such as perforation and bleeding, and the necessity of submucosal injections of expensive sodium hyaluronate^{10,11}. In our initial experience with ESD using an IT knife, the incidence of complications was 50% : among 14 cases, bleeding occurred in 5 cases and perforation occurred in 2 cases¹¹. Currently, colorectal ESD has gradually been carried out in some institutions with favorable results by the development of advanced equipment such as submucosal injection solutions, a high-frequency generator system, electro-surgical knives, surgical clips, closure devices and carbon dioxide (CO₂) insufflation system^{10,13~26}. Therefore, the development of an endoscopic electro-surgical knife (such as B-Knife) that would allow complete and safe removal of large flat lesions in a single fragment is necessary.

In 1942, Greenwood introduced the first bipolar system, which consisted of forceps with insulated blades³⁶. Later, a bipolar needle knife for minimally invasive endoscopic neurosurgery was developed to avoid tissue traumatization in cerebral structures (Bipolar Microprobe, ERBE Elektromedizin GmbH, Tübingen, Germany)³⁷. However, to our knowledge, the B-Knife is the first bipolar knife designed for use in the gastrointestinal tract. Our preliminary results from a bench study showed that tissue traumatization was much less with the B-Knife than with a needle knife and monopolar current^{28,29}. With the bipolar system, the current flows only through the tissue that is between the electrodes, therefore, one should be able to achieve desired tissue effects within the confines of the electrodes while producing only a circumscribed area of tissue injury, as has been demonstrated experimentally.

In our initial 3 cases, this procedure using the B-

Knife allowed complete removal of the lesion as a single large fragment. There were no major complications, and operating time (43 min) was no longer than that for ESD using monopolar current^{11,12}. Yamamoto et al. reported a similar EMR technique with ESD using a combination of monopolar needle knife, injection of sodium hyaluronate and small-caliber-tip transparent hood^{10,13}. However, they also remarked that indications for performance of this type of procedure requires prudent selection of colorectal lesions as skillful control of the endoscope tip and accessory devices are necessary. Further prospective investigation is required to compare ESD using the B-Knife with other ESD techniques for validation of these results.

We then examined the clinical outcomes of ESD using the B-Knife for 25 further patients with colorectal tumors. In this study, the en bloc resection, perforation and delayed bleeding rate were 84%, 4% and 0%, respectively, which are similar to current reports^{14~26}. Only two cases (8%), a pSM2 carcinoma and a local recurrence, underwent additional surgery after ESD. However, there have been no cases of recurrence thus far. Therefore, our findings show that ESD of colorectal tumors using the B-Knife gives a higher en bloc resection rate and results in less complications. In addition, the operating time for ESD was 91.6 min, which is similar to current reports^{20,24, 25}.

In conclusion, our preliminary results from a bench study and clinical outcomes of this study suggest that ESD using the B-Knife is reliable and safe for the complete resection of select large flat lesions in the colorectum.

Acknowledgements We would like to express an appreciation to Zeon Medical Inc., with special thanks to Shigeki Noda, Shiro Akagi, Ken Nishikawa and Toshikazu Onuki. We greatly thank Dr. Johji Imura (Department of Diagnostic Pathology, University of Toyama Graduate School of Medicine and Pharmaceutical Sciences, Toyama, Japan) and Yutaka Saito (Division of Endoscopy, National Cancer Center Hospital, Tokyo, Japan) for their help in organizing our research. We thank Dr. Kuang-I Fu (Department of Gastroenterology, Juntendo University Nerima Hospital, Tokyo, Japan.), Masao Hanafusa (Department of Gastrointestinal Oncology and Pathology, Osaka Medical Center for

Cancer and Cardiovascular Diseases, Osaka, Japan), Takahisa Matsuda (Division of Endoscopy, National Cancer Center Hospital, Tokyo, Japan), Hirohisa Machida (Department of Gastroenterology, Osaka City University Graduate School of Medicine, Osaka, Japan), Shigehiko Fujii (Department of Gastroenterology, Kyoto-Katsura Hospital, Kyoto Japan), Toshihiko Doi, Atsushi Ohtsu (Division of Digestive Endoscopy and Gastrointestinal Oncology, National Cancer Center Hospital East, Chiba, Japan) and Shigeaki Yoshida (Aomori Prefectural Hospital, Aomori, Japan) for their valuable advice. We also thank Dr. Nobunao Ikehara, Yoshinori Morita and Shiei Yoshida (Division of Diabetes, Digestive and Kidney Diseases, Department of Clinical Molecular Medicine, Kobe University Graduate School of Medicine, Kobe, Japan.) for assistance in experiments using swine. In addition, we thank Chiaki Matsuyama, Ayako Shimizu, Takako Ono, Midori Katayama, Atsuko Kikuchi, Nozomi Nagashima, Shizuka Kidachi (Department of Surgical and Molecular Pathology, Dokkyo University School of Medicine, Tochigi, Japan) for their excellent technical and secretarial assistance.

REFERENCES

- 1) Kudo S, Kashida H, Tamura T, et al : Colonoscopic diagnosis and management of nonpolypoid early colorectal cancer. *World J Surg* **24** : 1081-1090, 2000.
- 2) The Paris endoscopic classification of superficial neoplastic lesions : esophagus, stomach, and colon : November 30 to December 1, 2002. *Gastrointest Endosc* **58** : S3-43, 2003.
- 3) Tanaka S, Haruma K, Oka S, et al : Clinicopathologic features and endoscopic treatment of superficially spreading colorectal neoplasms larger than 20 mm. *Gastrointest Endosc* **54** : 62-66, 2001.
- 4) Saito Y, Fujii T, Kondo H, et al : Endoscopic treatment for laterally spreading tumors in the colon. *Endoscopy* **33** : 682-686, 2011.
- 5) Yokota T, Sugihara K, Yoshida S : Endoscopic mucosal resection for colorectal neoplastic lesions. *Dis Colon Rectum* **37** : 1108-1111, 1994.
- 6) Walsh RM, Ackroyd FW, Shellito PC : Endoscopic resection of large sessile colorectal polyps. *Gastrointest Endosc* **38** : 303-309, 1992.
- 7) Kunihiro M, Tanaka S, Haruma K, et al : Electrocautery snare resection stimulates cellular proliferation of residual colorectal tumor : an increasing gene expression related to tumor growth. *Dis Colon Rectum* **43** : 1107-1115, 2000.
- 8) Yamamoto H, Sunada K, Miyata T, et al : Endoscopic submucosal dissection using sodium hyaluronate for large superficial tumors in the colon. *Digestive Endosc* **16** : 178-181, 2004.
- 9) Gotoda T, Kondo H, Ono H, et al : A new endoscopic mucosal resection procedure using an insulation-tipped electrosurgical knife for rectal flat lesions : report of two cases. *Gastrointest Endosc* **50** : 560-563, 1999.
- 10) Yamamoto H, Koizumi H, Yube T, et al : A successful single-step endoscopic resection of a 40 millimeter flat-elevated tumor in the rectum : endoscopic mucosal resection using sodium hyaluronate. *Gastrointest Endosc* **50** : 701-704, 1999.
- 11) Sano Y, Machida H, Fu KI, et al : Endoscopic Mucosal Resection and Submucosal Dissection Method for Large Colorectal Tumors. *Dig Endosc* **16** : S93-96, 2004.
- 12) Saito Y, Emura F, Matsuda T, et al : A new sinker-assisted endoscopic submucosal dissection for colorectal cancer. *Gastrointest Endosc* **62** : 297-301, 2005.
- 13) Yamamoto H, Kawata H, Sunada K, et al : Successful en-bloc resection of large superficial tumors in the stomach and colon using sodium hyaluronate and small-caliber-tip transparent hood. *Endoscopy* **35** : 690-694, 2003.
- 14) Matsumoto A, Tanaka S, Oba S, et al : Outcome of endoscopic submucosal dissection for colorectal tumors accompanied by fibrosis. *Scand J Gastroenterol* **45** : 1337-1337, 2010.
- 15) Tamegai Y, Saito Y, Masaki N, et al : Endoscopic submucosal dissection : a safe technique for colorectal tumors. *Endoscopy* **39** : 418-422, 2007.
- 16) Hurlstone DP, Atkinson R, Sanders DS, et al : Achieving R0 resection in the colorectum using endoscopic submucosal dissection. *British Journal of Surgery* **94** : 1536-1542, 2007.
- 17) Fujishiro M, Yahagi N, Kakushima N, et al : Outcomes of Endoscopic Submucosal Dissection for Colorectal Epithelial Neoplasms in 200 Consecutive Cases. *Clin Gastroenterol Hepatol* **5** : 678-683, 2007.
- 18) Zhou PH, Yao LQ, Qin XY, et al : Endoscopic submu-

- cosal dissection for colorectal epithelial neoplasm. *Surg Endosc* **23** : 1546-1551, 2007.
- 19) Isomoto H, Nishiyama H, Yamaguchi N, et al : Clinicopathological factors associated with clinical outcomes of endoscopic submucosal dissection for colorectal epithelial neoplasms. *Endoscopy* **41** : 679-683, 2009.
 - 20) Saito Y, Taku Sakamoto T, Shusei Fukunaga S, et al : Endoscopic submucosal dissection (ESD) for colorectal tumors. *Dig Endosc* **21** (Suppl 1) : S7-S12, 2009.
 - 21) Iizuka H, Okamura S, Onozato Y, et al : Endoscopic submucosal dissection for colorectal tumors. *Gastroenterol Clin Biol* **33** : 1004-1011, 2009.
 - 22) Hotta K, Oyama T, Shinohara, T, et al : Learning curve for endoscopic submucosal dissection of large colorectal tumors. *Digestive Endoscopy* **22** : 302-306, 2010.
 - 23) Niimi K, Fujishiro M, Kodashima S, et al : Long-term outcomes of endoscopic submucosal dissection for colorectal epithelial neoplasms. *Endoscopy* **42** : 723-729, 2010.
 - 24) Yoshida N, Naito Y, Kugai M, et al : Efficient hemostatic method for endoscopic submucosal dissection of colorectal tumors. *World J Gastroenterol* **16** : 4180-4186, 2010.
 - 25) Toyonaga T, Man-I, M, Chinzei R, et al : Endoscopic treatment for early stage colorectal tumors : The comparison between EMR with small incision, simplified ESD, and ESD using the standard Flush knife and the ball tipped Flush knife. *Acta Chir Iugosl* **57** : 41-46, 2010.
 - 26) Uraoka T, Higashi R, Kato J, et al : Colorectal endoscopic submucosal dissection for elderly patients at least 80 years of age. *Surg Endosc* **25** : 3000-3007, 2011.
 - 27) Tanaka S, Nakayama N, Ozawa S, et al : Outcomes of colorectal ESD and its future prospects. *Endoscopy* *Digestiva* **24** : 24-31, 2012.
 - 28) Sano Y, Fu KI, Saito Y, et al : A newly developed bipolar-current needle-knife for endoscopic submucosal dissection of large colorectal tumors. *Endoscopy* **38** : 95, 2006.
 - 29) Sano Y, Saitoh Y, et al : Risk management of therapeutic colonoscopy (hot biopsy, polypectomy, endoscopic mucosal resection and endoscopic submucosal dissection). *Dig Endosc* **19** : S19-S25, 2007.
 - 30) Forde KA, Treat MR, Tsai JL : Initial clinical experience with a bipolar snare for colon polypectomy. *Surg Endosc* **7** : 427-428, 1993.
 - 31) Japanese society for cancer of the colon and rectum : Japanese classification of colorectal carcinoma, 2nd English edition. Kanehara & Co., Ltd., Tokyo, 2009.
 - 32) Yahagi N, Fujishiro M, Iguchi M, et al : Theoretical and technical requirements to expand EMR indications. *Dig Endosc* **15** : S19-21, 2003.
 - 33) Miyamoto S, Muto M, Hamamoto Y, et al : A new technique for endoscopic mucosal resection with an insulated-tip electro-surgical knife improves the completeness of resection of intramucosal gastric neoplasms. *Gastrointest Endosc* **55** : 576-581, 2002.
 - 34) Ono H, Kondo H, Gotoda T, et al : Endoscopic mucosal resection for treatment of early gastric cancer. *Gut* **48** : 225-229, 2001.
 - 35) Oyama T, Kikuchi Y : Aggressive endoscopic mucosal resection in the upper GI tract-Hook knife EMR method. *Minimally Invasive Therapy and Allied Technologies* **11** : 291-295, 2001.
 - 36) Greenwood J Jr : Two point coagulation. A follow-up report on a new technique and instrument for electrocoagulation in neurosurgery. *Archs Phys Ther* **23** : 552-554, 1942.
 - 37) Hellwig D, Haag R, Bartel V, et al : Application of new electro-surgical devices and probes in endoscopic neurosurgery. *Neurol Res* **21** : 67-72, 1999.