

The current issue and full text archive of this journal is available on Emerald Insight at:  
[www.emeraldinsight.com/2515-8961.htm](http://www.emeraldinsight.com/2515-8961.htm)

INMR  
15,2

118

Received 13 March 2017  
Accepted 25 April 2017

# Relationship between entrepreneurial orientation, marketing capability and business performance in retail supermarkets in Santa Catarina (Brazil)

Ismael Luiz dos Santos and Sidnei Vieira Marinho  
*Universidade do Vale do Itajai, Itajai, Brazil*

## Abstract

**Purpose** – This study aims to find evidence of a possible relationship between three constructs that are generally investigated separately: entrepreneurial orientation, understood as entrepreneurship on the organizational level; marketing capability, seen as a highly competitive factor for the organization; and business performance, highlighted as a focus of the entire organization.

**Design/methodology/approach** – A survey-based quantitative approach was adopted with a cross-sectional temporal perspective. To arrive at results that can be compared, the study uses factor analysis and structural equations modeling techniques, with estimations of maximum likelihood for testing the quality of fit of the measures to the structural models, using SPSS 21 and AMOS 16 software. Data were collected at the 27th EXPOSUPER, which is a trade fair at which 35,000 visitors were present. The data collection instrument used is a questionnaire previously validated by Reis Neto *et al.* (2013a). The first section covers control variables chosen to profile the firms, the second contains entrepreneurial orientation variables, the third comprises marketing capability variables and the fourth section contains business performance variables, all using seven-point Likert response scales.

**Findings** – Tests of the entrepreneurial orientation measurement scale produced interesting results in this application within the retail supermarket industry. The results of exploratory factor analysis indicated that a scale with three dimensions was significant. The relationship between entrepreneurial orientation and marketing capability (*H1*) is positive, through the intermediate dimensions of innovation, proactiveness and risk-taking, used by firms' management, contributing to their efforts to research and manage the market, to develop products and services and to offer better prices. Exploratory factor analysis and confirmatory factor analysis showed that four of the scale's dimensions of the marketing capability were significant: market research, market management, new product development and pricing. Comparison of these results with those of Reis Neto *et al.* (2013a) reveals a difference, as although their result, achieved using structural equations modeling, also had four factors; the promotion dimension was the most significant and absorbed the other variables. Despite these differences, confirmatory factor analysis and structural equations modeling demonstrated that this construct met the minimum conditions for adequacy, where (*H2*), formulated to test the relationship between the marketing capability construct, was confirmed. The final construct analyzed in this study was business performance, initially suggested by González-Benito *et al.* (2009), and also used by



---

Reis Neto *et al.* (2013a). They used the dimensions profitability, market value and market response, and in the present study, after exploratory factor analysis, confirmatory factor analysis and structural equations modeling, the results were identical to those authors results, in that (H3), formulated with the objective of testing the relationship between the entrepreneurial orientation construct and business performance, was confirmed, and although this was not the most robust of the relationships postulated in the three hypotheses, but was of lower significance.

**Research limitations/implications** – Although this study has achieved its objective, one of the study's limitations relates to the data collection instrument, which was subject to failures in terms of the number of variables to be analyzed in each dimension. This led to elimination of certain dimensions during the analyses. Another limitation is related to the method used in the study. When questionnaires are used as data collection instruments, respondents often may not understand the true meaning of questions, which could lead them to choose any option, thereby stripping the results of credibility. In view of this limitation, it is suggested that future researchers conduct qualitative studies, using the case study method, which could offer greater clarity and increase understanding of the results related to these subjects. Even considering that this study has certain limitations and restrictions affecting generalization, it is hoped that it raises new questions, interests and inspirations, improving and complementing understanding of this strong social and economic sector.

**Originality/value** – It is identify the relationship between entrepreneurial orientation and marketing capability, since to date there is no evidence from studies confirming the existence of such a relationship. This statement was based on the results of a bibliographic survey conducted using the ProKnow-C, knowledge development process-constructivist methodology, in which, this originality was positive and significant, offering new studies from this point of view.

**Keywords** Entrepreneurial orientation, Marketing capability, Business performance

**Paper type** Research paper

## 1. Introduction

There is fierce competition in the supermarket industry, forcing managers to constantly seek instantaneous information and obliging firms to embark on ventures, invariably with innovation, transforming themselves into proactive organizations, willing to take risks to maintain themselves in the market (Covin and Slevin, 1991; Lumpkin and Dess, 1996; Wiklund, 1999). The constant struggle for market share drives retail supermarkets to seek solutions based on a balance between capabilities and resources, so that they develop and introduce variables to improve organizational performance, such as market research, surveys of prevailing prices in the market, development of products and services, promotions and advertising and market management (Vorhies and Harker, 2000).

In this setting, entrepreneurship should not be considered a virtue, but a means of attaining, very often implicitly, superior performance for the organization, as it is notable that there is significant interest among firms in developing certain essential competencies as a means of increasing their competitiveness and improving their performance (Grant, 1991).

With regard to the sector's economic indicators, it is notable that after 13 years with no decline, during 10 of which there was real-terms growth; in 2015, revenues in self-service fell for the first time, according to data from a Nielsen study of the Brazilian Retail Structure (Leite and Nunes, 2016). Despite nominal growth of 7.1 per cent, two-digit inflation (10.67 per cent – IPCA) eroded the sector's real-terms performance (–3.25 per cent).

In 2016, the Santa Catarina supermarket industry's sales performance was positive, 1.14 per cent higher than the 2015 sales figure. These data are from monthly surveys of firms of all sizes conducted by the *Associação Catarinense de Supermercados* (ACATS), the supermarket industry association of Santa Catarina state (Leite and Nunes, 2016). The association's national counterpart, the *Associação Brasileira de Supermercados* (ABRAS), sets Santa Catarina's contribution at 6 per cent of the national market (Leite and Nunes, 2016).

It is known that strategies based on more refined information enable organizations to be better prepared for the market during periods of reduced consumption, and for this reason, the objective of this study is to analyze relationships between the constructs entrepreneurial orientation, marketing capability and business performance in retail supermarkets in Santa Catarina. This general objective was broken down into a series of specific objectives, such as to identify the relationship between entrepreneurial orientation and marketing capability, as to date there is no evidence from studies confirming the existence of such a relationship. This statement is based on the results of a bibliographic survey conducted using the ProKnow-C – knowledge development process-constructivist methodology (Ensslin *et al.*, 2010).

Another of the specific objectives was to test the relationship between marketing capability and business performance, as within the scope of marketing research, some studies have identified deficiencies in the process of organizational performance assessment (Guissoni and Neves, 2013; Ginevicius *et al.*, 2013).

The last of the specific objectives was to identify the relationship between entrepreneurial orientation and business performance, as Lumpkin and Dess (2001) have described a strong relationship between entrepreneurial orientation and business performance. It is also worth mentioning that Wales *et al.* (2013) point out that the number of studies investigating entrepreneurial orientation has increased considerably over time. The population sampled comprised 679 supermarket chains represented by 956 shops that took part in the industry's largest trade fair in the state of Santa Catarina, the 27th EXPOSUPER (2014). This research is quantitative and descriptive, using cross-sectional survey techniques and following recommendations made by Malhotra (2001) and Hair *et al.* (2009). Analyses of relationships between different variables followed recommendations by Hair *et al.* (2009), who suggest using the structural equations modeling technique with analysis by structural equations analysis. This requires filters to be applied in advance, which in this case were exploratory factor analysis and confirmatory factor analysis, and the variables were measured using seven-point Likert response scale.

The results of analysis of these relations are important for management in terms of understanding their industry's positions within the dimensions of each construct, providing evidence on which of the management characteristics that make up the constructs entrepreneurial orientation, marketing capability and business performance can help with decision-making.

## 2. Entrepreneurial orientation

Entrepreneurial orientation has emerged as an important factor for investigating firms' entrepreneurial spirit and its influence on strategic processes (Miller and Friesen, 1982; Miller, 1983; Covin and Slevin, 1991; Lumpkin and Dess, 2001; Zahra and George, 2002; Covin *et al.*, 2006; Rauch *et al.*, 2009; Martens *et al.*, 2011).

Theoretical contributions on this subject gained prominence after a publication by Covin and Slevin (1991) which portrayed entrepreneurship at the business level empirically and culminated in emergence of the construct of entrepreneurial orientation. After this publication, the construct began to be treated as an area within entrepreneurship studies because Lumpkin and Dess (2001) pointed out that there is a difference between entrepreneurship and entrepreneurial orientation.

The term entrepreneurial orientation refers to a series of dimensions, comprising processes, decision-making practices and activities that culminate in creation or re-creation of business ventures, including the propensity to act autonomously, a predisposition to

---

innovate and take risks, a tendency to competitive aggression in relation to competitors and pro-activity with relation to new opportunities (Lumpkin and Dess, 2001).

The pioneering work by Miller (1983), a series of publications inspired by work by Covin and Slevin (1991) and additional work by Lumpkin and Dess (2001) portray entrepreneurial orientation as dissemination of entrepreneurial practices and the related shared values that originate with firms' top management, so it can be stated that entrepreneurial orientation starts at the highest organizational levels and the objective is to disseminate practices for identification and exploitation of opportunities.

Different conceptualizations of entrepreneurial orientation diverge in terms of their definitions of its dimensions. Miller (1983) used three dimensions, namely, innovativeness, proactiveness and propensity for risk-taking, taking a unidimensional approach to the construct itself, while Lumpkin and Dess (1996) used five dimensions, namely, innovativeness, proactiveness, predisposition to risk-taking, autonomy and aggression, taking a multidimensional approach to the construct. Although the dimensions proposed by Miller (1983) are not unanimously accepted in the literature, nevertheless many of those who propose different dimensions in their studies also highlight the dimensions proposed by Miller and this is one of the reasons that this paper uses these dimensions, in addition to the fact that this study follows a proposal by Reis Neto *et al.* (2013a) who refer to a construct of entrepreneurial orientation comprising the dimensions: innovation, proactiveness and risk-taking, using a multidimensional approach which in turn is based on work by Naman and Slevin (1993).

Some recent definitions of the entrepreneurial orientation construct can be found in work by Meneses (2012), who describes a business model applied to firms that regularly innovate in decisions, taking risks in their strategies, whether in product or market, and in work by Tonial (2014) who defines it as a strategic process that guides organizations' decision-making, when they adopt entrepreneurial behavior.

In summary, entrepreneurial orientation is a path that entrepreneurs take to create a "new entry", which can be defined as creation of a new business, new products or technology or a new market. It can also be defined as a set of strategies within a conceptual domain encompassing results at the organizational level, related to management preferences, beliefs and behaviors expressed through managers.

Working from the arguments related to entrepreneurial orientation cited above, the first hypothesis that will be tested is as follows:

*H1.* There is a relationship between entrepreneurial orientation and marketing capability.

### 3. Marketing capability

Marketing capability is approached as a sustainable competitive advantage, mediated by distinctive capabilities (Grant, 1991; Hayes and Pisano, 1996), together with suggestions that these capabilities should be constantly reassessed for the purposes of expansion and to prevent imitability.

Tsai and Shih (2004) analyzed the relationship between marketing knowledge management and marketing capabilities and business performance. They used a scale developed by Kohli *et al.* (1993) to measure management marketing knowledge and adapted a scale by Vorhies and Harker (2000) to measure marketing capabilities, reducing it to four components (distribution channel, market research and product development, pricing, and promotional management), and they used a scale by Venkatraman and Ramanujam (1986, 1987) to measure performance. The study reported that managers with marketing

---

knowledge can expand these capabilities. They also found that firms with superior capabilities have better business performance than their competitors.

Vorhies and Morgan (2005) revised the dimensions of marketing capabilities, proposing eight dimensions, based on the dimensions used in a study by Vorhies and Harker (2000), as follows: price, marketing communication, sales, product development, distribution channel, marketing planning, marketing implementation and management of marketing information.

Marketing capabilities are the link between all of the firm's resources used to achieve competitive advantage (Ribeiro, 2006). Therefore, identification of which marketing capabilities have relationships with business performance and which practices support them and better understanding of how they are implemented within firms would contribute both to the literature and to management practice. This statement is supported by the results of Ribeiro's (2006) study, which was conducted with the objective of identifying and validating the dimensions of marketing capabilities, and reported in its results eleven possible dimensions:

- (1) strategic marketing planning;
- (2) information distribution;
- (3) customer services;
- (4) client monitoring and satisfaction;
- (5) customer relationship management and loyalty;
- (6) management of customer portfolio;
- (7) sales force management;
- (8) products and brand management;
- (9) innovation management;
- (10) distribution channel management; and
- (11) price management.

The scale used by Ribeiro (2006) is the result of combining the essence of the research proposal by Vorhies and Harker (2000) with concepts from Day (2001), which were translated into constructs and their corresponding practices.

It is clear that although several different studies have attempted to measure marketing capabilities (Tsai and Shih, 2004; Vorhies and Morgan, 2005; Ribeiro 2006), all of them have based their efforts of the dimensions defined by Vorhies and Harker (2000), proposing varying numbers of dimensions for assessment of marketing capabilities.

Having presented concepts related to marketing capability, this paper will adhere to the concept developed by Vorhies and Harker (2000), which can be described as follows: market research, through which the firm attempts to identify new customers, their wishes and requirements, evaluating which marketing programs should be maintained or whether new ones should be initiated. Product or service pricing, seeking information on and monitoring the competitiveness of the firm's prices within the market. Product development, which is verification of the firm's capacity to develop products or services that meet customers' requirements and surpass their main competitors' products. Management of distribution channels, which is founded on monitoring the relationship with and effectiveness of distributors. Promotion, which is understood as advertising, sales promotions and other sales activities used in communication with the market and to sell products or services. Market management is understood as the firm's capacity to manage customers' purchasing and market segmentation and to coordinate and implement its marketing programs.

---

Vorhies and Harker's (2000) conceptual interpretation of these six factors represents an important marketing concept, which will be referred to as marketing capability in this paper. One of its foci is to test the following hypothesis:

- H2. There is a relationship between marketing capability and business performance in the context of retail firms doing business in the supermarket industry of Santa Catarina.

As these are trading and services firms and are the final link in the chain, in direct contact with their customers, it was decided that the factor distribution channel would be discarded and, in common with Reis Neto *et al.* (2013a) and other authors mentioned above who have also used adapted versions of the Vorhies and Harker (2000) dimensions, the remaining five factors would be used.

#### 4. Business performance

Business performance originates in Taylor's and Fayol's precepts of scientific management, which influenced management theories of the time and still have repercussions today, based on the understanding that business performance should be assessed in terms of the concepts of efficiency and effectiveness. These terms are complementary, as when doing something, it is necessary to focus on the results desired (effectiveness), while using the available resources well (efficiency) and to achieve efficiency and effectiveness, the manager needs to exercise control. Effective control of performance requires information on true standards, in relation to those expected and those achieved, in addition to taking actions to correct deviations that occur occasionally.

Initially, business performance measures were exclusively concerned with measuring workers' productivity. Now they are also concerned with measurement of more complex and wide-reaching aspects, ranging from measurement of the performance of internal organization processes to measurement of aspects related to social responsibility, i.e. the firm's influence on social aspects, environmental impacts, influence on the community in which the firm exists, among others, and utilization, simultaneously, of objective and subjective performance indicators to ensure that the results observed are more reliable (Kaplan and Norton, 1997; Gulini and Rossetto, 2005).

It can be observed that business performance measurement models used to study organizations can be objective, objective-subjective or subjective and, according to Wang and Ang (2004), subjective measures are usually chosen because there is generally little information on small businesses because it is impossible to precisely confirm the quality of the information that is available and because accounting figures on small businesses are difficult to interpret in relation to the scenario of competition.

This paper approaches the business performance construct via the subjective views of the managers and owners of retail supermarket firms, using the measures profitability, market response and market value, assessed, as mentioned above, using the same research instrument as used by Reis Neto *et al.* (2013a). In other words, because of the nonexistence of reliable secondary data on the Santa Catarina supermarket industry, a subjective analysis of business performance in the dimensions of profitability, market response, and market value will be used to attempt to find evidence to support or reject the third hypothesis:

- H3. There is a relationship between entrepreneurial orientation and business performance.



## 5. Methodological procedures and research instrument

A survey-based quantitative approach was adopted, with a cross-sectional temporal perspective. To arrive at results that can be compared, the study uses factor analysis and structural equations modeling techniques, with estimations of maximum likelihood for testing the quality of fit of the measures to the structural models, using SPSS 21 and AMOS 16 software.

Data were collected at the 27th EXPOSUPER, which is a trade fair at which 35,000 visitors were present. The data collection instrument used is a questionnaire previously validated by [Reis Neto et al. \(2013a\)](#). The first section covers control variables chosen to profile the firms, the second contains entrepreneurial orientation variables, the third comprises marketing capability variables and the fourth section contains business performance variables, all using seven-point Likert response scales.

Control variables were collected using seven items: name of interviewee, name of firm, e-mail, job title, number of employees of the shop, number of shops in the chain and in which shop the interviewee works. In general, demographic information data collection is normally left to the last section of the questionnaire, but it was decided to ask these questions first so that they could be used as filters, as the focus of this research is on firms in the supermarket industry and people who have strategic positions, such as directors, managers, leaders and/or management-level employees who do not work in administrative departments.

The scales and variables used to measure entrepreneurial orientation have previously been used by [Reis Neto et al. \(2013a, 2013b\)](#). They comprise eight variables distributed across the subdimensions innovation, proactiveness and risk-taking ([Naman and Slevin, 1993](#)).

The variables that make up the construct marketing capability and its dimensions are a combination of knowledge of the firm's tangible and intangible resources, associating them with the needs and wishes of its consumers to develop an integrated process for adding value to the goods and services provided and increase competitiveness ([Hitt et al., 2003](#)). In total, 17 items that measure the marketing capability construct were used from the research instrument validated by [Reis Neto et al. \(2013a\)](#) and, as explained above, only the distribution channels dimension was excluded, as the focus is on supermarkets. These items are distributed across five subdimensions: market research, pricing, product development, promotion and market management ([Vorhies and Harker, 2000](#)).

The construct business performance was defined as respondents' perceptions of their results in comparison with their most important competitor. These variables were also operationalized using subjective measures from the [Reis Neto et al. \(2013a\)](#) research instrument because subjective performance measures offer one great advantage over objective measures of financial performance, which is that since businesspeople are more inclined to subjectively compare their businesses against their major competitor, they are more likely to answer subjective questions. The dimensions used in this study were profitability, market response and market value.

### 5.1 Stages and results of the analyses

After an initial selection process had filtered out questionnaires answered by people unrelated to the research objectives (firms not in the supermarket industry or employees who had purely operational roles, irrespective of whether they worked for supermarkets), the initial sample of 689 fully completed questionnaires was reduced to 372 valid questionnaires. Although this is a considerable reduction, 372 valid questionnaires are still a significant sample, as they included 229 supermarket chains, which represents 33.73

per cent of the ACATS members and 38.91 per cent of affiliated shops (as there were questionnaires from more than one shop in the same chain).

After filtering the questionnaires, extraction of results was initiated, starting with the characteristics of the sample, which showed that the chain size category with most respondents was two to five shops (49.34 per cent) and that the majority of chains comprised from 1 to 5 shops (83.40 per cent).

The next step was to conduct exploratory factor analysis, with the objective of evaluating the unidimensionality of entrepreneurial orientation and business performance variables. According to [Hair et al. \(2009\)](#), the factor loading for each construct should achieve a minimum value of 0.40. A selection of other standards was also assessed, as shown in [Table I](#).

Both multidimensionality and unidimensionality of constructs were assessed. All of the variables in each of the constructs should be related to each of the factors and correlate with each other, which is how each dimension, or factor, is identified. For a variable to be included in a construct, it must exhibit a factor loading that is  $\geq 0.7$  and a communality that is  $\geq 0.50$  ([Escobar et al., 2012](#)). It was considered that the constructs exhibited normality in the univariate analysis as, according to [Finney and Distefano \(2006\)](#), asymmetry coefficients in the range  $-2$  to  $+2$  and kurtosis from  $-7$  to  $+7$  are within normal limits.

The range of the means for the entrepreneurial orientation variables was notable (5.18 to 5.47), revealing the managers' perceptions that entrepreneurial orientation is important to their organizations. Values for marketing capability variables ranged from 5.03 to 5.72. This result is evidence that the respondents stated that their firms are always seeking to use these dimensions to understand and improve their capabilities. Finally, the business performance values ranged from 5.51 to 5.87, signifying that the majority of the managers believe that the results of their firms are better than those of their competitors.

With relation to the results of the exploratory factor analysis of the constructs, the communalities extracted for each indicator, the Kaiser–Meyer–Olkin measure of sampling adequacy (KMO), and the factor loadings for the single factor extracted are all important. All of the entrepreneurial orientation indicators exhibited positive correlations with each other, which is expressed by their communality values, indicating the percentage of variance that each item shares with the others. The reliability of each item is also reported, in terms of Cronbach's alpha, which should preferably be  $>0.5$  ([Hair et al., 2009](#)). As such, not all of the variables have adequate values, as one of the proactiveness variables had a value of 0.466 and was therefore eliminated.

With relation to the measure of sampling adequacy (KMO), [Hair et al. \(2009\)](#) suggest that the value should be  $>0.50$ . It can be observed that all of the values for the entrepreneurial orientation and business performance constructs are as expected, but one of the variables from the promotion dimension of marketing capability had communality and measure of sampling adequacy values  $<0.5$  and a factor loading  $<0.7$ . This variable was therefore excluded from the promotion dimension. All of the other variables in this dimension had satisfactory results, as did the variables for the dimensions market management, market research, pricing and new product development. Still with relation to marketing capability, which comprises five factors, the individual factor loadings for each dimension were analyzed. All of the factors for all five dimensions had eigenvalues  $>1$ , and total variance explained by marketing capability was 67.277 per cent. However, cross loadings of  $>0.3$  were observed, which are considered high and could indicate that a given dimension is explained by more than one factor, and there were just two variables in the promotion dimension, with no apparent values with factor loadings  $>0.3$ . For this reason, the decision



**Table I.**  
Results of analyses  
of constructs in data  
collected at  
EXPOSUPER 2014

VARIABLES	Mean	SD	Asymmetry	Kurtosis	Communality	Kaiser-Meyer-Olkin	Factor loading	Cronbach's alpha	Total variance	% of variance
<i>Entrepreneurial orientation</i>										
Innovation	1 5.36	1.402	-1.22	1.401	0.725	0.693	0.852	0.919	5.132	64.145
	2 5.41	1.333	-0.85	0.353	0.706	0.700	0.840			
	3 5.35	1.357	-0.65	-0.025	0.695	0.766	0.834			
Proactiveness	1 5.18	1.404	-0.64	-0.016	0.541	0.915	0.735			
	2 5.47	1.311	-0.93	0.441	0.466	0.892	0.682			
Risk-taking	1 5.29	1.311	-0.90	0.711	0.662	0.686	0.814			
	2 5.24	1.331	-0.65	0.092	0.633	0.758	0.795			
	3 5.29	1.406	-1.22	1.443	0.704	0.688	0.839			
<i>Marketing capability</i>										
Market research	1 5.57	1.166	-0.89	1.025	0.696	0.814	0.83	0.757	4.221	26.384
	2 5.45	1.228	-0.91	1.028	0.769	0.780	0.88			
	3 5.29	1.186	-0.86	1.073	0.686	0.845	0.83			
	4 5.47	1.206	-0.97	1.18	0.678	0.838	0.82			
Promotion	1 5.66	1.320	-1.37	2.071	0.034	0.490	0.18		1.062	6.636
	2 5.2	1.162	-0.74	0.815	0.656	0.500	0.81			
	3 5.18	1.260	-0.81	0.699	0.63	0.500	0.79			
	1 5.43	1.173	-0.82	0.492	0.733	0.676	0.86	0.757	1.851	11.571
Development of new products and/or services	2 5.12	1.182	-0.38	0.118	0.738	0.673	0.86			
	3 5.32	1.214	-0.73	0.403	0.647	0.759	0.8			
Pricing	1 5.32	1.200	-0.58	0.145	0.565	0.694	0.75		2.346	14.66
	2 5.19	1.159	-0.76	1.007	0.701	0.747	0.84			
	3 5.03	1.198	-0.48	0.277	0.708	0.742	0.84			
	4 5.16	1.252	-0.81	0.76	0.531	0.698	0.73			
Market management	1 5.39	1.172	-0.48	-0.21	0.662	0.631	0.81		1.284	8.027
	2 5.49	1.145	-0.60	0.141	0.536	0.719	0.73			
	3 5.72	1.204	-0.80	0.156	0.649	0.637	0.81			

(continued)

VARIABLES	Mean	SD	Asymmetry	Kurtosis	Communality	Kaiser–Meyer– Olkin	Factor loading	Cronbach's alpha	Total variance	% of variance
<i>Business performance</i>										
Profitability	1 5.52	1.046	-0.95	1.584	0.557	0.877	0.75	0.902	4.76	59.5
	2 5.51	1.056	-0.56	0.025	0.588	0.878	0.77			
Market response	1 5.87	1.068	-0.96	0.796	0.638	0.912	0.8			
	2 5.74	1.032	-1.00	2.02	0.679	0.921	0.82			
	3 5.79	0.958	-1.14	2.811	0.545	0.888	0.74			
Market value	1 5.76	1.052	-0.81	0.344	0.641	0.921	0.8			
	2 5.64	1.012	-0.63	0.013	0.596	0.913	0.77			
	3 5.57	1.140	-0.67	0.144	0.515	0.926	0.72			

**Note:** Number of valid responses: 372

**Table I.**

was taken to exclude the promotion dimension from the model because it had proven impossible to measure it using confirmatory factor analysis.

With regard to the factor loadings, and still according to [Hair et al. \(2009\)](#), values  $>0.7$  are considered ideal. However, values  $>0.5$  can be considered adequate and it was found that for this measure the factors for all constructs exhibited acceptable values. Other relevant analyses in exploratory factor analysis are the KMO test, Bartlett's test of specificity and Cronbach's alpha. The results of these tests were all considered adequate, as they exhibited the minimum expected values for each measure. For example, the Cronbach's alpha results were 0.919 for the entrepreneurial orientation construct, 0.757 for the marketing capability construct and 0.902 for the business performance construct. The matrix's factorability can therefore be confirmed.

Having verified all of the constructs, it was then possible to construct a measurement model comprising 29 manifest or observable variables using structural equations modeling, analyzing the measures of the model's fit, significance levels and magnitude of the regression coefficients estimated for the relationships proposed in the research hypotheses.

The procedures proposed for structural equations modeling are illustrated in [Figure 1](#).

When using structural equations modeling, there is no single method for fitting the model, as they vary depending on model complexity. As suggested by [Hair et al. \(2009\)](#), this study uses measures that compare observed data with the model's predictions as follows: absolute measures of fit, incremental measures of fit and parsimonious measures of fit.

According to [Hair et al. \(2009\)](#), the most appropriate method in structural equations modeling for validating the constructs of the model individually is confirmatory factor

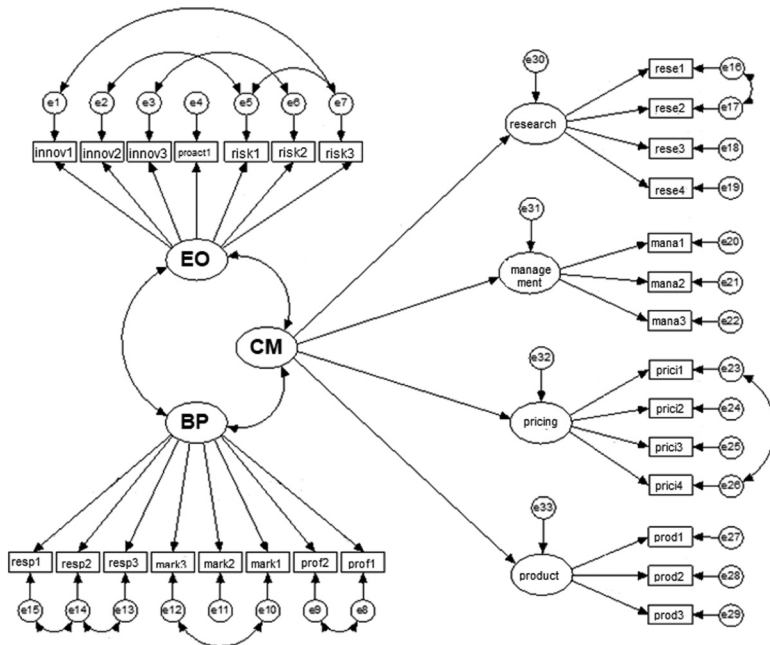

Figure 1.  
Structural and  
measurement model

Source: Study data

analysis, as it provides information on the validity of constructs: factor loadings, reliability, convergent validity and discriminant validity.

Exploratory factor analysis was used to estimate factor loadings to verify unidimensionality of the constructs' entrepreneurial orientation and business performance, identifying that some indicators had high cross-loadings. Cronbach's alpha coefficients were calculated to test the reliability of constructs, thereby ensuring that the results produced would be consistent. According to [Hair et al. \(2009\)](#), Cronbach's alpha can vary from 0 to 1 and values  $\geq 0.6$  are acceptable.

Still, following the recommendations of [Hair et al. \(2009\)](#), the next step was validation of the model with relation to the relationships hypothesized between the latent variables of the construct. In other words, the indices of model fit and the significance and magnitude of the regression coefficients estimated for each structural equation defined for the relationships between latent variables were verified.

A regression coefficient is identified by means of analysis of its *t*-values, where values greater than 1.96 define a minimum significance level of 0.05, according to [Garver and Mentzer \(1999\)](#). [Hair et al. \(2009\)](#) state that defining a regression coefficient as significant is subject to the consideration that the relationship between the variables tested is confirmed empirically.

The authors state that it is important to conduct the complementary test of the coefficient of determination ( $R^2$ ) of a structural equation because it indicates the proportion of the variance of the dependent variable attributable to the group of independent variables represented by the structural equation. The greater the coefficient of determination, the greater the regression equation's explanatory power and the better the dependent variable's prediction.

Structural equations modeling also enables investigation of the extent to which the independent or exogenous variables are capable of explaining a dependent or endogenous variable. [Table II](#) lists the fit indices for the general measurement model.

In summary, the analyses of the data collected for this study using exploratory factor analysis were performed with the 33 observable variables that comprise the three constructs: entrepreneurial orientation, business performance and marketing capability. After these analyses, only 32 were identified as observable variables, as the variable proactiveness 2 exhibited an exploratory factor loading of 0.466 and was therefore eliminated. The remaining variables underwent tests that are described below to identify whether they were relatively significant for measurement of the study constructs.

A structural model can be described as a representation of a collection of relations of dependence, connecting the different constructs. The measurement model determines which

**Table II.**  
Fit indices for the general measurement model with minimum desirable values compared to the values estimated by the adjusted model of data collected using questionnaires administered at EXPOSUPER 2014

Classification	Measures	Minimum desirable values	Values for adjusted model
Absolute fit indices	X2		482.487
	P	<0.050	0.00
	X2/df	<3	1.273
	RMSEA	<0.080	0.027
Incremental fit indices	NFI	$\geq 0.900$	0.934
	CFI	$\geq 0.900$	0.985
	TLI	$\geq 0.900$	0.983

manifest variables are related to each latent variable. The observable variables are obtained from questions developed by the researcher and answered by the interviewees. They can also be called indicators (Hair *et al.*, 2009). The results are expressed in the diagram of the measurement model for all constructs with their respective standardized estimates, as shown in Figure 2.

Having conducted the statistical tests with SPSS and AMOS 16, analysis of the significance and magnitude of the parameters estimated enables confirmation or rejection of the hypotheses. The results are shown in Table III, where  $p$ -values  $< 0.001$  are indicated by \*\*\*.

The data shown in Table III describe the relationships between constructs, with  $p$ -values indicating significance, as all are  $< 0.001$ , showing, together with the standardized coefficients, that all hypotheses were confirmed, as follows.

*H1.* It was concluded that this relationship exists and is positive, with emphasis on the dimensions innovation, proactiveness and risk-taking, used by the firms' management, contributing to the efforts they make to research and manage the market, develop products and services and offer better prices, as these results exhibited a standardized factor loading of 0.680, i.e.  $> 0.50$ , always significant to  $p < 0.05$ .

Confirmation of this hypothesis enables part of the objective to be met, i.e. to identify the relationship between entrepreneurial orientation and marketing capability, concluding that entrepreneurial orientation, through its dimensions innovation, proactiveness and risk-taking, is related to the dimensions of market research, development of new products, pricing and market management. It is worth emphasizing that there are no previous studies relating these constructs to date. Even Reis Neto *et al.* (2013a) did not detect these

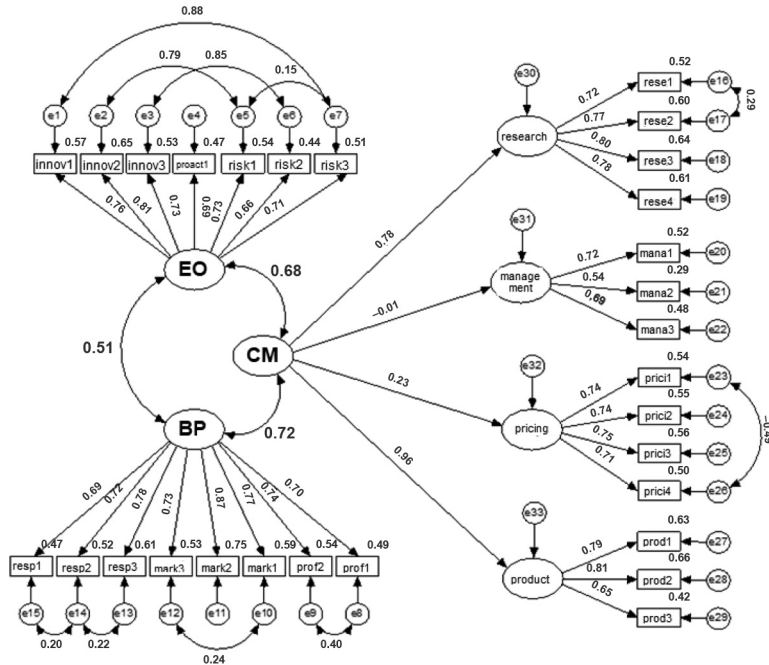

**Figure 2.** Diagram for the measurement model of all constructs with their respective standardized estimates

**Source:** Results of research analysis

relationships, despite stating that the greater the entrepreneurial orientation and marketing capability, the better the business performance.

*H2.* This hypothesis was also confirmed, corroborating the results of earlier studies that had demonstrated a positive relationship between application of marketing capability strategies and business performance, such as work by Vorhies and Harker (2000), Moore and Fairhurst (2003), Tsai and Shih (2004) and Vorhies and Morgan (2005). It is also noteworthy that the relationship was confirmed by a positive standardized factor loading of 0.716, which is considerably higher than the minimum acceptable value of  $>0.50$ . This result enabled another of the objectives to be achieved: identification of a relationship between marketing capability and business performance.

*H3.* It can be concluded that this hypothesis was also confirmed, corroborating the results of a considerable proportion of previous studies of entrepreneurial orientation and business performance (Covin and Slevin, 1991), as the relationship was shown to be positive. There is the similarity of this result with the works of Covin and Slevin (1991) and Lumpkin and Dess (1996), who investigated entrepreneurial orientation and stated that the dimensions innovation, proactiveness and risk-taking are major competitive factors that offer organizations the possibility of sustaining their share in the business world, reporting that entrepreneurial orientation made a significant contribution to business performance.

This hypothesis was confirmed with a standardized factor loading of 0.513, achieving another part of the objective, which was to identify a relationship between entrepreneurial orientation and marketing capability.

With regard to the primary objective of this study, which was to analyze the relationship between entrepreneurial orientation, marketing capability and business performance in retail supermarket firms from Santa Catarina, Brazil, all of the research predictions were completely confirmed and the results can be expressed as follows: *There are relationships between entrepreneurial orientation, marketing capability and business performance in the Santa Catarina supermarket industry and these relationships are significant and positive.*

Relationship	Hypotheses	Standardized coefficient	<i>p</i> values	Status
<i>H1</i> Entrepreneurial orientation → Marketing capability	There is a relationship between entrepreneurial orientation and marketing capability	0.680	***	Confirmed
<i>H2</i> Marketing capability → Business performance	There is a relationship between marketing capability and business performance	0.716	***	Confirmed
<i>H3</i> Entrepreneurial orientation → Business performance	There is a relationship between entrepreneurial orientation and business performance	0.513	***	Confirmed

Note: \*\*\*  $< 0.001$

**Table III.**  
Parameters estimated from the structural model and summary of hypotheses and their status, according to data collected using questionnaires administered at EXPOSUPER 2014



---

The preceding sections have covered the theoretical foundation, the conceptual model and the results of the study. The next section presents final comments.

### 6. Final comments

The primary objective of this study was to find evidence of a possible relationship between three constructs that are generally investigated separately: entrepreneurial orientation, understood as entrepreneurship on the organizational level; marketing capability, seen as a highly competitive factor for the organization; and business performance, highlighted as a focus of the entire organization. Three hypotheses were formulated to achieve this objective: *H1*, *H2*, and *H3*.

This research project began by defining a theoretical foundation, developed from previous studies through application of the ProKnow-C methodology. It was found that one of these studies presented a questionnaire that had been validated and suggested its application in the industry studied here. This enabled development of a model that was validated and adjusted separately, generating an integrated (hybrid) model. This led to a better-adjusted model, suited to testing the research hypotheses.

Tests of the entrepreneurial orientation measurement scale produced interesting results in this application within the retail supermarket industry. As stated by [Reis Neto et al. \(2013a\)](#), this scale needed testing in other retail sectors, as it had been applied in the retail industry in general in the state of Mato Grosso do Sul (Brazil). The results of exploratory factor analysis indicated that a scale with three dimensions was significant. The relationship between entrepreneurial orientation and marketing capability (*H1*) is positive, through the intermediate dimensions of innovation, proactiveness and risk-taking, used by firms' management, contributing to their efforts to research and manage the market, to develop products and services and to offer better prices.

It can further be stated that this result confirming *H1* is the study's greatest contribution, as a survey of extant theory using the ProKnow-C methodology showed that, until this study was conducted, there had been no studies confirming this relationship.

The marketing capability scale was originally developed by [Vorhies and Harker \(2000\)](#) with six dimensions and applied in this study in an adapted version proposed by [Reis Neto et al. \(2013a\)](#), excluding the distribution channels dimension. Exploratory factor analysis and confirmatory factor analysis showed that four of the scale's dimensions were significant: market research, market management, new product development and pricing. Comparison of these results with those of [Reis Neto et al. \(2013a\)](#) reveals a difference, as although their result, achieved using structural equations modeling, also had four factors, the promotion dimension was the most significant and absorbed the other variables.

Despite these differences, confirmatory factor analysis and structural equations modeling demonstrated that this construct met the minimum conditions for adequacy, where *H2*, formulated to test the relationship between the marketing capability construct, through the dimensions market research, product/service development, pricing, promotion and market management and business performance, through its dimensions profitability, market response and market value, was confirmed, corroborating, with a positive confirmation, the results of studies by [Vorhies and Harker \(2000\)](#), [Moore and Fairhurst \(2003\)](#), [Tsai and Shih \(2004\)](#) and [Vorhies and Morgan \(2005\)](#).

This relationship leaves management in no doubt about the importance of investment in marketing capabilities, as in retail supermarkets, this relationship has a

---

considerable impact on performance, i.e. the greater the investment in marketing capabilities, the greater the perceived profitability, market response and market value. This evidence is in line with managers' own practices, analyzing their pricing and advertising daily and seeking to understand how their customers relate to the promotions they plan.

The final construct analyzed in this study was business performance, initially suggested by [González-Benito \*et al.\* \(2009\)](#) and also used by [Reis Neto \*et al.\* \(2013a\)](#), with used the dimensions profitability, market value and market response, after exploratory factor analysis, confirmatory factor analysis and structural equations modeling, the results were identical to those authors results, in that (*H3*), formulated with the objective of testing the relationship between the entrepreneurial orientation construct and business performance, was confirmed and, although this was not the most robust of the relationships postulated in the three hypotheses, but was of lower significance, confirms results of other studies, such as: [Vorhies and Harker \(2000\)](#), [Moore and Fairhurst \(2003\)](#), [Tsai and Shih \(2004\)](#), and [Vorhies and Morgan \(2005\)](#), in addition to [Reis Neto \*et al.\* \(2013a\)](#).

With regard to the overall objective of this study, to analyze the relationships between entrepreneurial orientation, marketing capability and business performance in the retail supermarket firms from Santa Catarina affiliated to the ACATS, all three hypotheses were confirmed.

As this is an empirical, cross-sectional, non-probabilistic study, analyzing the retail sector of a limited region and with typical economic conditions, it is recognized that the conclusions cannot be generalized, even though the results are supported by the recent literature cited. It can however be inferred that these observations may also be present in the other firms in this industry in conditions similar to those found in Santa Catarina. The data collected provide knowledge on what managers do, but it is also very important to know how they actually do it.

It is suggested that this research be extended, collecting data from firms prospectively and investigating the principal retail sectors such as supermarkets, clothing stores, pharmacies, building materials, hospitality, tourism and others to obtain better understanding of the causal relations between control variables, competitive factors and business performance in each segment. It is recommended that the relationships with business performance be extended with objective and subjective data collection, testing them in the context of Brazilian small businesses. Although this study has achieved its objective, which was to evaluate the relationships between entrepreneurial orientation, marketing capability and business performance, there are certain limitations that affect its scope and the processes used. One of the study's limitations relates to the data collection instrument, which was subject to failures in terms of the number of variables to be analyzed in each dimension. This led to elimination of certain dimensions during the analyses. Another limitation is related to the method used in the study.

When questionnaires are used as data collection instruments, respondents often may not understand the true meaning of questions, which could lead them to choose any option, thereby stripping the results of credibility. In an attempt to eliminate this possibility, before the questionnaire was administered, a pre-test was conducted to minimize failures to understand the questions. In view of this limitation, it is suggested that future researchers conduct qualitative studies, using the case study method, which could offer greater clarity and increase understanding of the results related to these subjects.

Even considering that this study has certain limitations and restrictions affecting generalization, it is hoped that it raises new questions, interests and inspirations, improving

and complementing understanding of this strong social and economic sector. One suggestion for future research is to repeat this study on the national level. Another recommendation is that future studies relate additional constructs to entrepreneurial orientation, marketing capability and business performance to test whether there are relationships. For example, it would be interesting to study relationships with learning orientation and organizational innovativeness.

### References

- Covin, J.G., Green, K.M. and Slevin, D.P. (2006), "Strategic process effects on the entrepreneurial orientation – sales growth rate relationship", *Entrepreneurship Theory and Practice*, Vol. 30 No. 1, pp. 57-81.
- Covin, J.G. and Slevin, D.P. (1991), "A conceptual model of entrepreneurship as firm behavior", *Entrepreneurship Theory & Practice*, Vol. 16 No. 1, pp. 7-25.
- Day, G.S. (2001), *A Empresa Orientada Para O Mercado*, Bookman, Porto Alegre.
- Ensslin, L., Lacerda, R. and Tasca, J. (2010), "Proknow-C, knowledge development process–constructivist", *Processo técnico com patente de registro pendente junto ao INPI*.
- Escobar, M.A.R., Lizote, S.A. and Verdinelli, M.A. (2012), "Relação entre orientação empreendedora, capacidade de inovação e munificência ambiental em agências de viagens", *Turismo, Visão e Ação*, Vol. 14 No. 2, pp. 269-286.
- Finney, S.J. and Distefano, C. (2006), "Non-normal categorical data in structural equation modeling", in Hancock, G.R. and Mueller, R.O. (Eds), *Structural Equation Modeling: A Second Course*, 2nd ed., Information Age Publishing, Charlotte, NC.
- Garver, M.S. and Mentzer, J.T. (1999), "Logistics research methods: employing structural equation modeling to test for construct validity", *Journal of Business Logistics*, Vol. 20 No. 1, pp. 33-57.
- Ginevicius, R., Podvezko, V. and Ginevicius, A. (2013), "Quantitative evaluation of enterprise marketing activities", *Journal of Business Economics and Management*, Vol. 14 No. 1, pp. 200-212.
- González-Benito, O., González-Benito, J. and Muñoz-Gallego, P.A. (2009), "Role of entrepreneurship and market orientation in firms' success", *European Journal of Marketing*, Vol. 43 No. 3, pp. 500-522.
- Grant, R.M. (1991), "The resource-based theory of competitive advantage: implications for strategy formulation", *California Management Review*, Vol. 33 No. 3, pp. 114-135.
- Guissoni, L. and Neves, M. (2013), "Ensaio sobre a análise de desempenho em marketing e aplicação de métricas", *Revista Brasileira De Marketing*, Vol. 12 No. 4, pp. 201-229.
- Gulini, P.L. and Rossetto, C.R. (2005), "Comportamento estratégico e ambiente organizacional: um estudo de caso no setor de provedores de internet de Santa Catarina", *IV Congresso De Administração – Gestão Estratégica Nas Organizações*, Anais, UNIFENAS, Alfenas, Vol. 4.
- Hair, J.F., Jr, Black, W.C., Babin, B.J., Anderson, R.E., and Tatham, R.L. (2009), *Análise Multivariada De Dados*, 5th ed., Bookman, Porto Alegre.
- Hayes, R. and Pisano, G. (1996), "Manufacturing strategy: at the intersection of two paradigm shifts", *Production and Operations Management*, Vol. 5 No. 1, pp. 25-41.
- Hitt, M., Ireland, R. and Sirmon, D. (2003), "A model of strategic entrepreneurship: the construct and its dimensions", *Journal of Management*, Vol. 29 No. 6, pp. 963-989.
- Kaplan, R.S. and Norton, D. P. (1997), *A Estratégia Em Ação: Balanced Scorecard*, 6th ed., Campus, Rio de Janeiro.
- Kohli, A.K., Jaworski, B.J. and Kumar, A. (1993), "MARKOR: a measure of market orientation", *Journal of Marketing Research*, Vol. 30 No. 4, pp. 467-477.

- 
- Leite, R. and Nunes, R. (2016), "Vendas mostram estabilização no primeiro quadrimestre", *ABRAS Economia*, Vol. 64, pp. 1-2, available at: <http://abrasnet.com.br/edicoes-anteriores/Main.php?MagID=7&MagNo=182>
- Lumpkin, G.T. and Dess, G.G. (1996), "Clarifying the entrepreneurial orientation construct and linking it to performance", *Academy of Management Review*, Vol. 21 No. 1, pp. 135-172.
- Lumpkin, G.T. and Dess, G.G. (2001), "Linking two dimensions of entrepreneurial orientation to firm performance: the moderating role of environment and industry life cycle", *Journal of Business Venturing*, Vol. 16 No. 5, pp. 429-451.
- Malhotra, N.K. (2001), *Pesquisa De Marketing: Uma Orientação Aplicada*, Bookman, Porto Alegre.
- Martens, C.D.P., Freitas, H.M.R., Boissin, J.P. and Behr, A. (2011), "Elementos da inovatividade no setor software: estudo exploratório em organizações empreendedoras do Rio Grande Do Sul", *Revista De Administração E Inovação*, Vol. 8 No. 1, pp. 248-279.
- Meneses, M.F. (2012), *A Relação Entre Orientação Empreendedora, Capacidade Dinâmica De Absorção E Desempenho Nos Hotéis Familiares Do Centro De Manaus*, Universidade do Vale do Itajaí, UNIVALI, Balneário Camboriú, p. 109.
- Miller, D. (1983), "The correlates of entrepreneurship in three types of firms", *Management Science*, Vol. 29 No. 7, pp. 770-791.
- Miller, D. and Friesen, P.H. (1982), "Innovation in conservative and entrepreneurial firms: two models of strategic momentum", *Strategic Management Journal*, Vol. 3 No. 1, pp. 1-26.
- Moore, M. and Fairhurst, A. (2003), "Marketing capabilities and firm performance in fashion retailing", *Journal of Fashion Marketing and Management: An International Journal*, Vol. 7 No. 4, pp. 386-397.
- Naman, J.L. and Slevin, D.P. (1993), "Entrepreneurship and the concept of fit: a model and empirical tests", *Strategic Management Journal*, Vol. 14 No. 2, pp. 137-153.
- Rauch, A., Wiklund, J., Lumpkin, G.T. and Frese, M. (2009), "Entrepreneurial orientation and business performance: an assessment of past research and suggestions for the future", *Entrepreneurship Theory and Practice*, Vol. 33 No. 3, pp. 761-787.
- Reis Neto, J.F., Muñoz-Gallego, P.A. and Souza, C.C.O. (2013a), "As conexões entre orientação empreendedora, capacidade de marketing e a percepção do desempenho empresarial: evidências empíricas das micro e pequenas empresas varejistas", *Ram. Revista De Administração Mackenzie*, Vol. 14 No. 3, pp. 236-271.
- Reis Neto, J.F., Muñoz-Gallego, P.A. and Souza, C.C.O. (2013b), "O papel da orientação empreendedora no relacionamento entre orientação Para o mercado e desempenho empresarial: evidências das pequenas empresas do comércio", *Read. Revista Eletrônica De Administração (Porto Alegre)*, Vol. 19 No. 1, pp. 115-138.
- Ribeiro, A. (2006), "Proposta de uma nova escala Para medir competências em marketing", *Revista De Administração e Inovação*, Vol. 3 No. 1, pp. 5-20.
- Tonial, G. (2014), *Orientação Empreendedora Internacional Na Indústria Vinícola Do Sul Do Brasil*, Universidade do Vale do Itajaí, UNIVALI, Biguaçu.
- Tsai, M.T. and Shih, C.M. (2004), "The impact of marketing knowledge among managers on marketing capabilities and business performance", *International Journal of Management*, Vol. 21 No. 4, pp. 524-530.
- Venkatraman, N. and Ramanujam, V. (1986), "Measurement of business performance in strategy research: a comparison of approaches", *Academy of Management Review*, Vol. 11 No. 4, pp. 801-814.
- Venkatraman, N. and Ramanujam, V. (1987), "Measurement of business economic performance: an examination of method convergence", *Journal of Management*, Vol. 13 No. 1.
- Vorhies, D.W. and Harker, M. (2000), "The capabilities and performance advantages of market-driven firms: an empirical investigation", *Australian Journal of Management*, Vol. 25 No. 2, pp. 145-173.

- 
- Vorhies, D.W. and Morgan, N.A. (2005), "Benchmarking marketing capabilities for sustainable competitive advantage", *Journal of Marketing*, Vol. 69 No. 1, pp. 80-94.
- Wales, W.J., Gupta, V.K. and Mousa, F.T. (2013), "Empirical research on entrepreneurial orientation: an assessment and suggestions for future research", *International Small Business Journal*, Vol. 31 No. 4, pp. 357-383.
- Wang, C.K. and Ang, B.L. (2004), "Determinants of venture performance in Singapore", *Journal of Small Business Management*, Vol. 42 No. 4, pp. 347-363.
- Wiklund, J. (1999), "The sustainability of the entrepreneurial orientation-performance relationship", *Entrepreneurship Theory & Practice*, Vol. 24 No. 1, pp. 37-48.
- Zahra, S.A. and George, G. (2002), "Absorptive capacity: a review, reconceptualisation, and extension", *Academy of Management Review*, Vol. 27 No. 2, pp. 185-203.

#### **Further reading**

- Lizote, S. (2013), "Relação entre competências empreendedoras, comprometimento organizacional, comportamento intraempreendedor e desempenho em universidades", *Doctoral thesis submitted to the Universidade do Vale do Itajaí*.

#### **Corresponding author**

Ismael Luiz dos Santos can be contacted at: [ismael.luiz.santos@gmail.com](mailto:ismael.luiz.santos@gmail.com)