

JISTEM - Journal of Information Systems and Technology Management
Revista de Gestão da Tecnologia e Sistemas de Informação
Vol. 10, No. 1, Jan/Apr., 2013 pp. 99-118
ISSN online: 1807-1775
DOI: 10.4301/S1807-17752013000100006

BEEF TRACEABILITY BY RADIO FREQUENCY IDENTIFICATION SYSTEM IN THE PRODUCTION PROCESS OF A SLAUGHTERHOUSE

Eliana Tiba Gomes Grande

Goiano Federal Institute - Iporá Campus, GO, Brazil

Sibelius Lellis Vieira

Pontifical Catholic University of Goiás, GO, Brazil

ABSTRACT

The goal of this work was to analyze the feasibility of continuing the traceability of beef through the use of Radio Frequency Identification technology in the production process of a slaughterhouse. In this process, the relationship between the end product (a piece of meat and the offal) and its source (the animal) is not maintained, even if the animal has been traced until the slaughterhouse. In the present work, critical points in the production process involving loss of traceability were identified and simulations using the middleware fosstrak and an associated simulator to validate a solution to this problem were performed. It was found that traceability is feasible, provided that the antennas and the RFID readers are placed in strategic locations such as the hooks where the carcasses are hanged and on the trays with the cuts of meat.

Keywords: middleware fosstrak, traceability - RFID, beef – industry, production engineering.

1. INTRODUCTION

The Brazilian beef market has evolved in the product quality delivered to the consumers through investments in genetics, improved pastures, balanced cattle feed for each development stage, humane slaughter (Roça, 1999), meat processing following the rules of health surveillance (BRASIL, 2007) and in the search for new technologies such as the Mobile Information and Wireless Technologies (Costa, 2010). However, product traceability does not meet the end user requirements with regard to providing a safe product with high palatable and organoleptic characteristics, by controlling all stages of production, processing, storage and transportation. The animals that use the Brazilian System of Identification and Certification of Bovine and Buffalo Origin (SISBOV) as a means of traceability lose their identity when they are slaughtered and their products are referenced to only by the batch of animals. The Radio Frequency Identification systems (RFID) technology can ensure that traceability is continued after slaughter, increasing the added value to the end product, expanding the possibility of

Manuscript first received/*Recebido em* 06/07/2012 Manuscript accepted/*Aprovado em:* 03/01/2013

Eliana Tiba Gomes Grande, Master in Production and Systems Engineering - PUC GOIAS, Goiano Federal Institute - Iporá - GO - Brazil Address Avenida Oeste s/n, saída para Piranhas – Iporá/GO – ZIP: 76.200-000 E-mail: eliana.tiba@ifgoiano.edu.br

Sibelius Lellis Vieira - Doctor in Electrical Engineering – Unicamp. Affiliation - Pontifical Catholic University of Goiás - GO - Brazil, Av. Universitária, n.1069, Setor Universitário, Goiânia/GO - ZIP: 74605-010 E-mail: sibelius@pucgoias.edu.br

Published by/ *Publicado por:* TECSI FEA USP – 2013 All rights reserved.

exportation and decreasing tax evasion with the strict control of production. RFID technology is a revolution in the identification process of goods, persons and services, with a direct impact on inventory and access control to logistic processes in the entire supply chain. Smart labels are more resistant than bar codes, have greater storage capacity and data reusability. These are some of the positive factors of using such a technology.

This technology can monitor all development phases of the animal (breeding, raising and fattening), generating important data control such as vaccinations, diseases, weight gain, including traceability control. Thereby, it becomes possible to improve logistics control (Nogueira, 2005), since it allows to inform the exact position, in real time, of the animals leaving the farms until their arrival at the slaughterhouses, and from then to the commercial establishments, and finally to customers, enabling to expand the competitiveness of Brazilian agriculture in the international market (Campanhola, 2005). Furthermore, the use of RFID technology also allows inventory control with greater reliability of data provided at the time of the events at any point in the production chain.

The Radio Frequency Identification Technology is widely used in the supply chain, in which generally there is only a tag read and a transfer of the data to the upper layers, generating real-time information for decision making (Schuster et al., 2007). In the slaughterhouse, at all times, there is a dismemberment of the an animal carcass generating different cuts of meat, as well as the aggregation of various cuts of meat from different animals in the same package, which leads to difficulties in maintaining the traceability of the animal identity.

The dismemberment and subsequent aggregation of the end product information of each processing stage are the critical control points for the implementation of the RFID system. In most processes, only the aggregation (assembly) of various pieces occurs in order to create a product (Krajewski et al., 2009).

Regarding the difficulties of the current tracking and the search for new technologies that will increase the quality of the product, the following questions are presented: Is the deployment of RFID within the slaughterhouse feasible? What are the critical points where traceability could be lost in the production process? Does the system really ensure the traceability of the end product, considering the specificities of this production process?

1.1. Objective

The objective of this study was to identify the feasibility of traceability within the continuity of the production process of a beef slaughterhouse, to establish critical points of traceability loss in the production process and to propose a solution that guarantees the traceability and perform simulations with the use of computing environments to prove the viability of this proposal.

There is as an empirical justification to the little importance given to the great effort made by rural enterprises in the use of information technology such as electronic scales, earrings and readers, which treats each animal individually in order to produce a higher quality product and with high added value in the market, if all this information is lost (discarded) in the slaughterhouse. However, analyses of the continuity of traceability within the production process are scarce, which stimulated the accomplishment of this work.

2. THEORETICAL FOUNDATIONS

2.1. The Brazilian beef market

It is noticeable that the agribusiness sector has contributed to the Brazilian trade balance. However, the global demand for agricultural products is relatively decreasing and the variability of prices and quantities of agricultural trade have been higher than manufactured products, and the agricultural trade exchange relationships have declined over the last 30 years (Carvalho & Silva, 2005). These facts place the country in a vulnerable position. In this case, the adoption of the replacement of importation by exportation of manufactured products becomes relevant, and increasing the volume of the agricultural products exported does not necessarily mean improvement of the Brazilian society welfare.

Statistical data of livestock production in 2010 shows that nearly 29 million bovines were slaughtered, a number that is still in continuous growth, according to the Brazilian Institute of Geography and Statistics (IBGE, 2010) indicators, presenting advances in productivity indexes and finishing of products. Out of this total, more than 1.23 million tons of beef were exported in 2010, to a record value of US \$ 3,896.90 per ton (BRASIL, 2011).

Brazil exports to over 170 countries, having as largest importers Russia, China, the Middle East countries, the United States and Europe (ABIEC, 2011). Beef is the third in the ranking of the most exported products of the country, encompassing both fresh and industrialized meat, edible offal and salted tripe (BRASIL, 2011).

The farmer's adherence to traceability resulted in the identification of individual animals in the herd size control of each category and in the possibility of determining a performance and reproduction quality. Therewith, new information controls were acquired, such as Animal Identification Document (DIA), the purchase documentation, the use and output of inputs (nutritional and sanitarian) and animal transportation documents. However, there has been no return from SISBOV system to support beef cattle farmers in their decision making (Cocaro & Jesus, 2007).

One of the reasons for the absence of information return to the beef cattle farmers is given by the lack of continuity of traceability after the slaughter. The adherence of RFID technology in the manufacturing process of slaughterhouses can ensure traceability of most animal products and byproducts.

2.2. The radio frequency identification technology

RFID technology is an automatic identification system that aims to provide information on people, pets, assets and products without human interference (Finkenzeller, 2003), so to speak, it can automatically reduce potential human errors (Glover & Bhatt, 2007). EPCglobal Inc. is a nonprofit organization that aims to establish the EPCglobal as a global standard for automatic identification. EPCglobal is a collection of inter-related hardware, software, data standards and essential services that are operated by EPCglobal and its delegates (Traub et al., 2010).

RFID technology is based on radiofrequency waves to exchange data, allowing remotely storing and retrieving information in order to waive the proximity or even the presence of an operator. As there is no need of human interference to specifically perform the entering data task, it is an automatic means of data capturing.

The RFID architecture is arranged in three layers. The physical layer consists of a set of hardware formed by tags, antennas, receivers/transmitters, a reader (interrogator)

of the RFID and computers, or any other devices that can view or manage the data provided by this environment.

. In the second or intermediate layer, where the RFID middleware is found, the data provided by the physical layer is summarized and organized and forwarded to the application layer. The third layer is where the information technology systems, Enterprise Resource Planning (ERP) or dedicated systems are located, which process the data provided by the intermediate layer and transform them into valuable information for business processes and decision making.

In order to standardize the communication between the layers and enable data to be understood, no matter the technology and systems used in each company, a standard known as *EPCglobal* was developed. This standard specifies the Electronic Product Code (EPC) in order to facilitate the information exchange and negotiation between physical objects, to promote the existence of a competitive market for components of the system and encourage innovation of products and systems.

2.3. The physical layer

The operation of the physical layer of RF technology is based on transponders (tags) installed in products that communicate with the antenna (fixed or mobile) and it sends the data to the RFID reader and then the reader transfers these synthesized data to hosts (Figure 1).

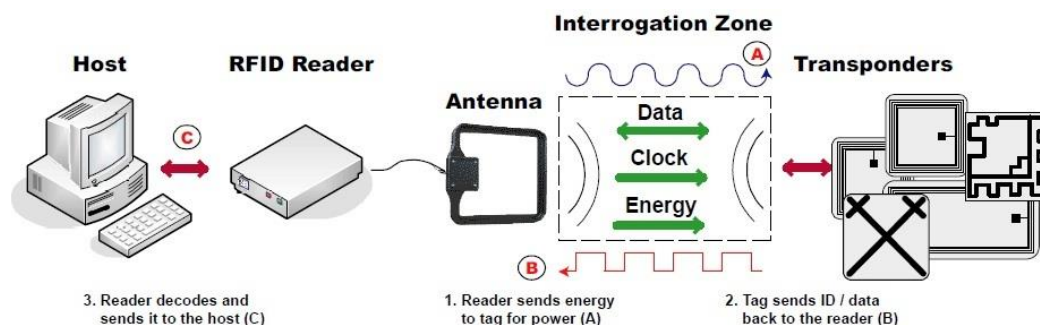

Figure 1 - Physical Architecture of RFID (GLOVER & BHATT, 2007)

The RFID antenna transmits a wave that has both magnetic and electric characteristics, hence the name electromagnetic wave. The use of the antenna depends on the circumstances of its operation and the narrow frequency range designated by the RFID system. The types of antennas are linear and circular polarized and monostatic and bistatic circular polarized.

The antenna is connected to the RFID reader/interrogator. The readers/interrogators can exchange information in one direction (half duplex communication – from the tag to the reader) or two-way (full duplex communication – from the tag to the reader and from the reader data can be written on the tag). The two types of communication take place by means of radiofrequency waves in broadcast, which happens in the reader's interrogation zone, namely, within the reach of the waves.

The transponders are RF tags or simply RFID tags which have as a basic structure a chip capable of storing information and one impedance performing as an antenna protected by a material such as plastic or silicone. The transponder (tag) is responsible for identifying a being or object carrying it when this being or object passes through the reader's interrogation zone, being it passive or active (Santini, 2008).

2.4. The intermediate layer

The EPC Middleware is software whose goal is managing the data captured by the readers/interrogators and providing these data to the EPC Information Services (EPCIS) and enterprise systems (Grumovski, 2009). The implementation of a middleware, in a general and basic way, for a RFID system is divided into three sublayers (Figure 2):

- Data transmission sublayer: contains different models of tags and readers which identify the physical tags and readers in order to enable them to communicate.
- Operating sublayer: contains the middleware that makes the integration among the different readers with different systems. It is in this layer that various valid tags readers are identified and all of them are aggregated into the same information.
- Business sublayer: the entire infrastructure of a company that uses the RFID system. It is characterized by a great heterogeneity due to different types of platforms supported.

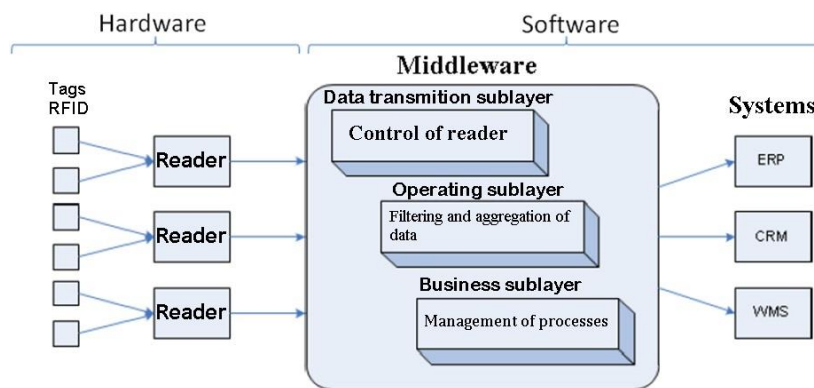

Figure 2 - General Architecture of RFID middleware (FLOERKEMEIER et al., 2007)

2.5. The EPCglobal Network

The EPCglobal Network is responsible for the standardization of the EPC code and aims to facilitate the information exchange and negotiation between physical objects, to promote the existence of a competitive market for the components of the system and encourage innovation of products and systems (Traub et al., 2010).

The EPCglobal standards include data standards and information exchange standards that form the basis of business exchange and also the specification for RFID devices and rules that manage the EPCs data coding in these devices.

The EPCglobal standards define the interfaces between system components that facilitate interoperability of components produced by different manufacturers. These systems provide choices for the end users, both in the systems' implementation between trading partners and internal company use (Schuster et al., 2007).

The EPC is an identification and naming scheme designed to identify univocally, among the participating countries, all physical objects, virtual and services commercialized. The "unique identity" means simply to assign a name to the entity, in such a way that a certain name is different from any other assigned by another entity.

The EPCglobal network architecture, the unique identity is the EPC, is defined by the specification of the tag data. The digits that make up the EPC are divided into two parts: one that identifies the manufacturer and the other one, the product type. However, the EPC uses an additional set of digits which are a serial number for exclusive item identification.

The EPCglobal network is structured in essentially six elements which are:

- EPC Number: global and exclusive identifier, which serves to hold queries on the object it identifies.
- Reader or interrogator: data capture device, portable or fixed, which connects to the network.
- EPC Middleware: software that controls the readers. It works with or without a local repository of EPC numbers and associated information.
- Application-Level Events (ALE) Specification: this is the interface standard application-level developed by the EPCglobal that allows customers to obtain consolidated and filtered EPC observations from a variety of sources.
- Object Name Service (ONS): shared resource that has information associated to the EPC number (equivalent to the Domain Name System (DNS) of the Internet).
- EPCIS: EPC information service that contains all the data for an EPC. It uses Physical Markup Language (PML) which is a language defined in Extensible Markup Language (XML) in order to enable query and obtain data related to EPC numbers.

2.6. The Fosstrak and Rifi di Emulator platform

The middleware has as its functions in the management of information and communication, meeting the needs of generic and independent platform application set. It must simplify communication applications through abstractions and support resource sharing to distributed applications, which means it leaves the platform transparent for applications, besides filtering and aggregating the data received from the physical layer (Bernstein, 1996).

Fosstrak meets all the functionality required by a middleware system, with an easy-to-use intuitive interface. Additionally, Fosstrak has the EPCglobal Network certificate, as it meets the EPC standard requirements (Floerkemeier et al. 2007).

The Fosstrak platform is an RFID open source system that implements the EPC Network specifications. This platform is divided into four modules (Fosstrak, 2012), as shown in Figure 3:

- EPCIS repository;
- Client application;
- Filtering and Collection Middleware with ALE;
- Support for Low Level Reader Protocol (LLRP), and LLRP Commander.

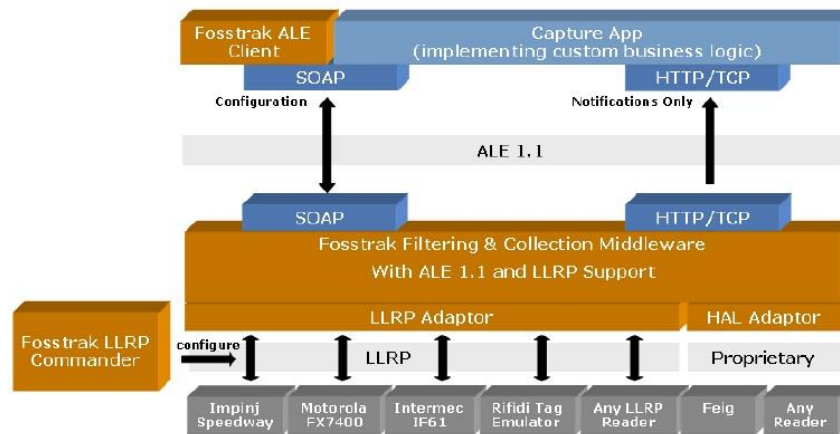

Figure 3 - Fosstrak with ALE and Middleware supports LLRP (<http://www.Fosstrak.org/fc/> modified by author)

Rifidi Emulator is used to create a simulation of the physical layer, including tags and readers (Rifidi, 2012).

The LLRP Commander is a plug-in that must be installed in Eclipse. The LLRP Commander makes use of the Eclipse environment to create, modify and manipulate XML messages between the simulator and the client application layer. Once Rifidi Emulator simulation is created, Tomcat can be activated in order to enable ALE Webclient configuration.

To view the reports with aggregated data sent from the Fosstrak ALE Middleware, the application that displays incoming requests Hyper Text Transfer Protocol (HTTP) is started. This application represents the client layer, where the generated filtered result is located and middleware aggregation is made available to the upper layer, the business layer. Once the communication between the Emulator and Rifidi Fosstrak is started, the screen that represents the client application should automatically receive the information from the lower layers.

After the Fosstrak Webclient ALE setting up, the middleware can be run by Eclipse. In this environment, logical readers are created to connect the physical readers to the Rifidi Emulator.

The middleware Fosstrak sends messages to the Rifidi Emulator simulator in order to receive readings from the tags within its coverage area. The result of these readings is also sent to the middleware in form of messages.

The report visualized in Fosstrak refers to the tags read from time to time within the Rifidi Emulator reader's coverage area. This time is determined by the middleware and can be changed by the user on the display module and editing XML message LLRP in the LLRP commander.

The middleware Fosstrak filters and aggregates the tags readings sent by Rifidi Emulator and make them available to the client application.

2.7. The structure of a slaughterhouse

Taking into account a slaughterhouse that performs the slaughter and meat industrialization, we have the following steps: animals reception at the corrals, drive to the slaughter, overhead spray on animals before slaughter, stunning, bleeding, skinning, evisceration, the split carcase in two half carcasses, refrigeration, cutting/ boning and storage/shipping.

At the reception stage the animals are examined by health surveillance inspectors for physical verification. After the inspection, the animals are separated into batches by origin and gender. They remain in the stalls waiting for a ranging period between sixteen to twenty-four hours, where they lie to spare muscle glycogen and water undergoing diet (Thornton, 1969).

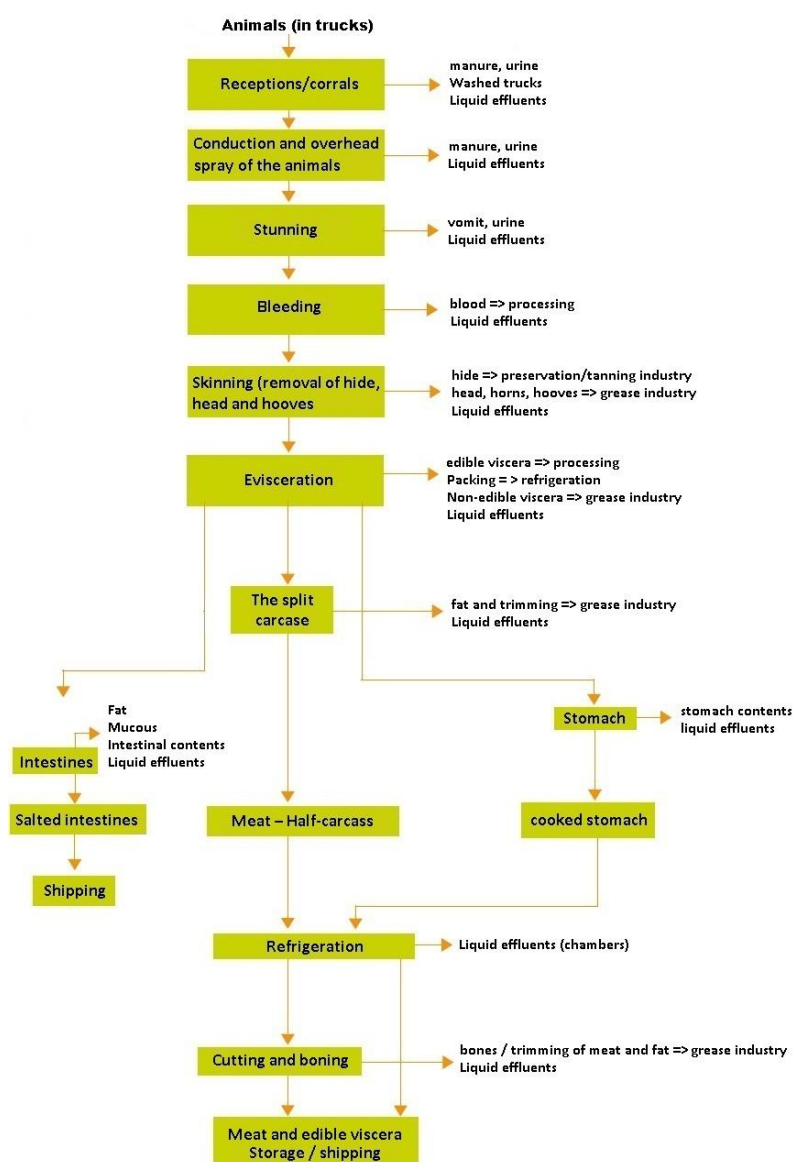

Figure 4 – Basic flowchart of bovine slaughter

Source: Slaughter Environmental Technology Guide (beef and pork) - Series modified by authors

Once the rest period is finished, the animals are led into a hallway with several divisions and separated into smaller lots for slaughter. This corridor named "syringe" tapers to such a point where the animals walk in a single line. Throughout the way the

animals are overhead sprayed with chlorinated water with pressure regulated jets removing manure and other animal dirt before slaughter (Steiner, 1983).

Stunning is the method used to deaden the animal before slaughter in itself. When the animals reach slaughter, they go into a narrow box where they are deadened with the application of the stunning method. This method seeks to eliminate unnecessary suffering of the animal (Cortesi, 1994), provides an efficient bleeding, and yet a high quality meat for commercialization.

During bleeding, the animals are tied by chains to one of the hind leg. When the skinning stage is over the animals are hung on hooks where they remain until the boning stage. Still in the skinning stage, the front legs are removed, keeping the hooves. Then the free hind leg is removed (the one which is not tied to the chains), the removal of hide is initiated and the first hook is introduced. After that, the other hind leg is removed and hung on the second hook and the skinning process is continued. To avoid contamination of the carcass, the bladder and anus are tied up. The hooves are inspected and if approved, sent for processing. Otherwise, they are sent to the production of flour.

The end products resulted from the skinning process are the hide, head, horns and hooves. In this stage also the tail, the reproductive organs of the female animals, the testicles of the male animals and subsequently the heads are removed manually with the use of knives (Figure 4). The heads are washed and inspected in their cavities (mouth, nose, pharynx and larynx). At this point, the carcass is assessed, classified and typified by age, gender and typed to exportation or not.

Evisceration is the removal process of the abdominal and pelvic organs, including the intestines, the bladder, the three pre-stomach (reticulum, rumen and omasum) and the true stomach (abomasums). The parts are poured into trays and inspected. The edible viscera such as liver, heart, kidneys are immediately packed and sent for cooling. The intestines are cleaned and from them tripe is produced which is salted in for processed meat or for medical applications use. The stomach is also emptied, cleaned and salted; sometimes bleached and refrigerated for subsequent dispatch. Gallbladder bile is extracted which is sold to pharmaceutical companies.

After evisceration, the carcass is sawed in half lengthwise, following the umbilical cord. The half carcasses are washed to remove all spinal cord traces and small fat nibs and/or tissues without meat. At this stage, the carcass is typified according to maturity, finishing, forming and hot yield. Completed the weighing, the two half carcasses are sent for refrigeration.

The use of low temperatures slows the onset of microbial activity as well as enzymatic and chemical reactions which modify the color and texture of meat. The chambers have their temperature stabilized between 0 and 4 ° C. Thus, the housing temperature is set around 7 ° C, so that the meat does not freeze and the blood does not drain ensuring its softness. The carcasses remain under refrigeration between 24 and 48 hours.

After the refrigeration period, the half carcasses are sent to be deboned, if not sent directly for shipping. This process is performed manually, using only knives. The parts are vacuum packed, labeled, boxed and sent for refrigeration (Figure 4).

Depending on the destination of the meat, it is routed to different storages. In the storage chambers, the sealed boxes are kept at a temperature of 0 ° C, administered by the "First In, First Out" (FIFO) method. When sent to distant destinations, the meat goes through a freezing process called "freezing tunnels", at a temperature of -35 ° C for 48

hours. After frozen, the packets are routed by conveyor belts to freezing chambers, which are stacked on pallets, where they remain until they are shipped.

3. METHODOLOGY

The challenge of this work is to describe a proposal of a traceability mechanism in a collection and processing of information environment that is provided by the SISBOV system, or even those that were recorded by the slaughterhouse at the animals reception time in the corral, in such a way that that information is kept up to shipment of products. The points where this information could be damaged during the production process must be detected in order to conduct an analysis of how a tracking system based on RFID can avoid this situation. For each of these points there should be made a description of the information passing through the layers of the RFID system.

In order to raise these issues, a qualitative and exploratory in nature research was used. In the qualitative approach it is important to visit the organization researched in order to collect evidence and observations, focusing on the processes under study. Understanding the processes can result in a map, which is the reflection result of the researcher about the territory investigated. It must work with more than one source of evidence, based on the literature review and the subjective reality of individuals captured in the natural environment of the research, in order to allow the construction of an objective reality in the research perspective. The ways to capture this complexity are the semi-structured (or non-structured) interview, participant observation and documentary research. Both confidentiality of sources and the name of the organization are sometimes required (Miguel, 2010).

In the combined approach, exploratory in nature, the intention is to explore the theme of research in order to provide subsidies for the quantitative phase. The aim is to generalize the results to different groups to which the result can be applied.

The method used was the case study, a strategy that fits in situations where issues should respond primarily to how and why, and to understand the context of the problem. A protocol based on bibliographic research, technical visit, with direct observation by the authors, interviews and process simulation software were used.

The technical visit happened in late 2010 in one of the establishments of a large slaughterhouse in the country, located in Goiânia which, for private reasons, administrators asked not to disclose its identity. With the production manager monitoring, the whole internal processes of the slaughterhouse were shown and described, starting from the purchase of the animals to the storage and shipping area. This visit was facilitated with the escort of a cattle farmer who has a business relationship with the company. The general manager assigned the production manager as instructor-guide of the entire production process.

The interview was conducted in a non-structured format with a professor from the Federal University of Goiás, Advanced Campus Jataí with experience in veterinary medicine, and emphasis on technology and inspection of animal products. This professor provided information on the process of a functional slaughterhouse, including electronic materials and comments for preparation of use cases.

Based on the theoretical research, the technical visit and documents provided by the UFG professor, the relevant points in the production process were raised, points considered as the ones where the identification of the animal is lost. These points are

identified as the skinning, evisceration and boning. For each of these points, a description of proceedings of the information passing through the layers of the RFID system was described. These points are defined as use cases, which must be carried out a series of actions based on pre-established events.

Another concern issue refers to economic factors and flexibility, which make it essential to conduct experiments with RFID hardware independently. In the search for solutions to solve this problem, the Fosstrak was found. This free and open system, which is EPCglobal certified, proved to be an appropriate solution for this study. It also communicates with an emulator called Rifidi Emulator that facilitates usability testing without the need for acquisitions of antennas, readers and electronic tags.

4. ANALYSIS OF THE PROBLEMS AND PROPOSAL OF SIMULATED SOLUTIONS

Based on the theoretical research, the technical visit and documents provided by the UFG professor, the relevant points in the production process were collected, which are the ones where the animal identification tracking is lost.

The SISBOV guarantees the traceability of the animal identity to the slaughter, and then its identity tracking is lost, and from then on the animals are grouped and identified in batches. This new identification is recorded in the meat packages. With the RFID system implemented within the production process of the slaughterhouse, this tracking can be continued with inclusions of new information such as classification, typifying, stay in the establishment and destination of the products of the animal.

Moreover, one can have a strict control of the quantity of meat sold versus the number of slaughtered animals, preventing tax evasion on the part of some clandestine slaughterhouses and slaughter carried out by small establishments which do not follow the rules of health surveillance.

The dismemberment and subsequent aggregation of end products information of each processing stage are the critical control points for the implementation of the RFID system. In the majority of the traditional production processes, there is only the aggregation (assembly) of multiple pieces (parts) to create a final product.

The RFID system is widely used in the supply chain, in which there is only a tag reading and transfer of the data to the upper layers, generating real-time information for decision making. In the slaughterhouse it is common to dismember the animal into various meat cuts and to aggregate the various cuts of meat from different animals in a package, which causes great difficulty preserving the relationship between the animal and the end product.

The Rifidi Emulator was used to create a simulated manufacturing process of slaughterhouse. Readers have been created in the relevant stages of the production process, such as in skinning, gutting, cutting, refrigeration, stock, in the tunnels freezers and freezing chambers. The tags were created to represent the tags contained in the components (hooks, conveyor belts, etc.) and dragged into the antennas of the readers.

Several reasons have led to the use of simulation to conduct feasibility tests in the production process of a slaughterhouse to maintain the animal traceability. The first one is because this simulation system is free of charge. The second is that the simulation can be made before the actual system is implemented. The third reason is the lack of an environment to perform these simulations in general.

The first use case to be described is to record the association of the hooks with the animal during skinning. Upon skinning, the antenna located at the initial position of skinning identifies only one tag, which is the one from the animal. Each animal is referenced to two hooks, and each hook references one half carcass (left or right) of the animal. This association is feasible because the tag of the hook is fixed and possibly already recorded in the system and the animal tag recorded by the time it reaches the skinning phase.

The tag embedded in the bottom or implanted in the animal is not the only form of prior animal identification. The SISBOV considers as valid forms for animal identification an earring and a standard bottom/button, an earring or a standard bottom/button and a electronic device, a standard earring in one ear and a tattoo on the other one, a standard earring and the SISBOV management number marked with a hot iron, a single device with visual and electronic identification and only a standard earring. This paper considers only the forms of identification tags that have been built or deployed.

When this antenna identifies the second tag, which is the hook, the connection should occur between the hook and the animal. At this moment the two reading tags are recorded in a database that connects them, along with the current time of reading. The next tag that refers to the next hook must also be recorded in the database that refers to the same animal. From this point, when the arrival tag was removed or lost, the animal identification can be obtained from the database.

The second use case is in the evisceration. In the evisceration, the viscera are poured into trays which also have the EPC code, in which the animal is again referenced to. Once the inspection releases the process, the tags are read and an EPC code that references to all animals is printed as well which offal are in the same package. The package is not assembled with the parts of an animal alone, but with the parts that come from various animals. The business plan establishes the number of pieces per package. This information is passed to the RFID middleware, which makes filtering and aggregation of tags and returns to the dedicated system, recording the package.

As described, the trays labeled with tags receive the viscera of the animal; these tags are already known by the system. During the visit that was made by the one of the authors, it was found that the viscera are separated. Edible offal are placed in one tray, and in another one, the stomach and intestines.

The edible offal are dumped into a tunnel to the packaging. Subsequently, the packing case is set up and sent for refrigeration. Each package receives an electronic tag with the identification of cattle from which they are originated. This is possible since there is synchronization between the hooks and trays. The reader identifies the hook of the tags that is referenced to the animal and passes it to the system. Another reader identifies the tray that is receiving the viscera, and passes the information to the system that associates the tray with the animal.

In the slaughterhouse's current production system the edible offal of several animals are packet together, which makes it impossible to identify which animals are in the same package. Therefore, the association between the tag of the hook and the tag of tray is needed. The stomach and intestines cannot receive identification of the animal from which they are originated, as they are processed among thousands of other animals.

The third use case of this work is during the boning process. Before the boning itself, the half carcass is divided into forequarter and hindquarter. The quarters, which are sold in this way, receive a label with the EPC code, which informs all the animal data. In case the quarters are sent for boning, several pieces of various animals are placed into a plastic bag to form a package, which hinders the identification of which animals make up the package. Again, tracking is necessary during the boning process through the association between the tags of the conveyor belt and the tags of the hooks at the entrance of this process.

4.1. Use case – recording the association of the tags of the hooks with the ones of the animal during the skinning stage

The first use case consisted of recording the association between the tags of the hooks with the ones of the animal during the skinning stage, and it begins with the identification of the first tag, which belongs to the animal. This information is read from time to time by the reader and forwarded to the middleware, which filters and aggregates this information into a single data, forwarding it to the client application (Figure 5).

In Figure 5 it is shown the three open applications, connected to one another. The first one, left of the screen, is the client application (in this case, a client application called Event Sink). The second, at the right bottom of screen, is the physical layer simulator, the RifiDi Emulator. The third, at the upper right of the screen, is the middleware Fosstrak using the LLRP Commander to communicate with the RifiDi Emulator.

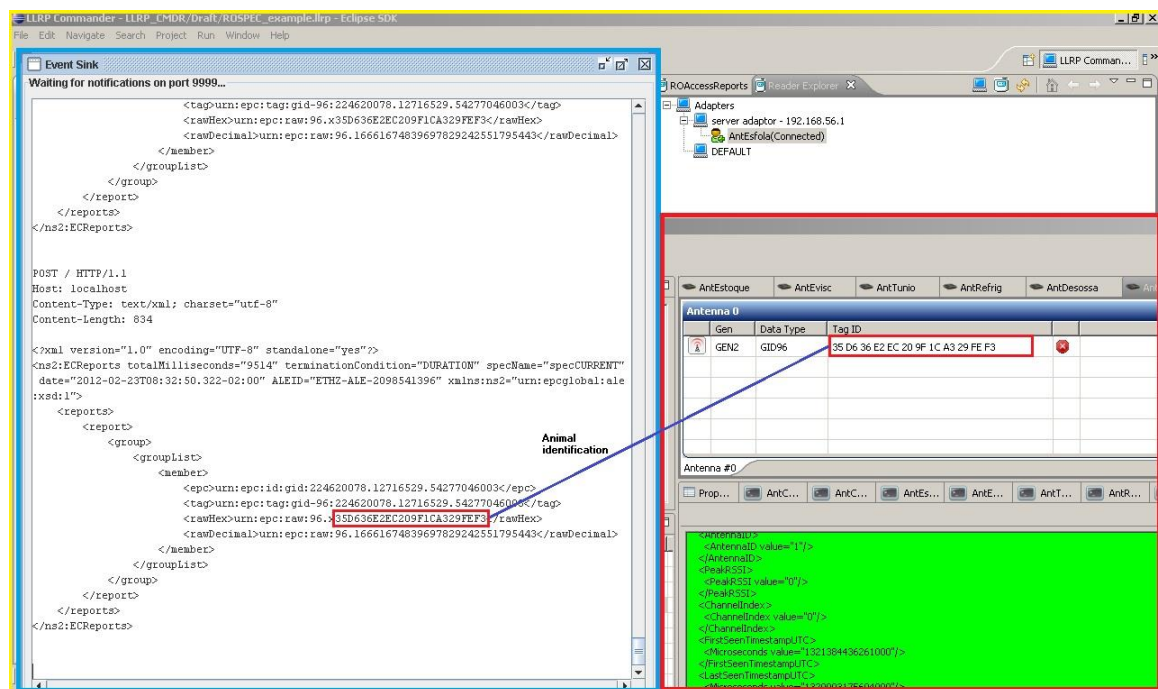

Figure 5 - First stage of the simulation of the skinning stage (animal identification)

As each half carcass is hung by its hind legs on two distinct hooks, the identification of the first hook is carried by the same reader which generates the association between the hook and the slaughtered animal. Thereby, the hook is associated with the animal, making the previous identification irrelevant, which allows one to remove the tag, but still guaranteeing the animal tracking along the remaining manufacturing process of slaughterhouse, which is illustrated in Figure 6.

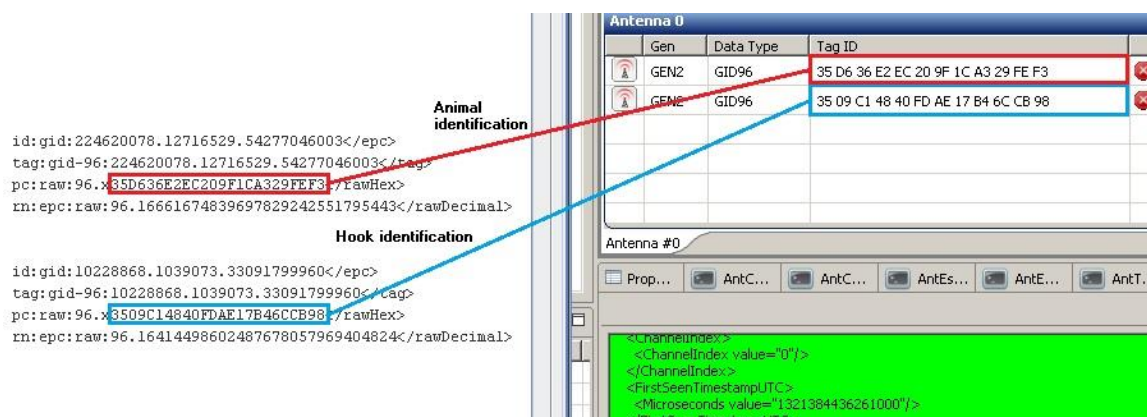

Figure 6 - Second stage of the simulation of the skinning phase (identification of the first hook)

The second hook is also identified by the antenna and associated to the animal (Figure 7). It can be seen in this figure the emulation of the skinning stage by Rifidi Emulator, through the reading operation sent message, an access report type message (ROAccessReport) to the middleware Fosstrak. The sent message appears in the "ROAccessReport" Fosstrak middleware tab as a list containing the following data: date/time, the adapter used over the IP of the machine (server), the reader and the EPC code, among others.

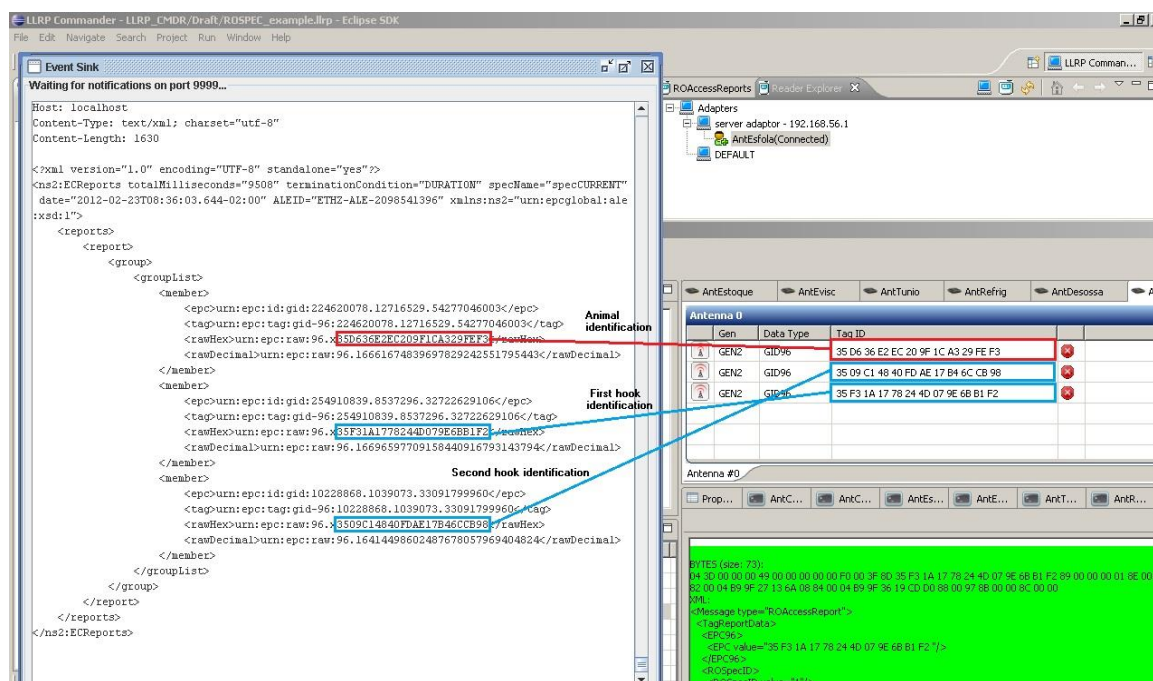

Figure 7 - Third stage of the simulation of the skinning phase (identification of the second hook)

The middleware Fosstrak matches the EPC codes that do not repeat and generates a report from this reader making it available to the client application, called Event Sink, which is illustrated on the left of the screen in Figure 7.

4.2. Use case 2 - recording the association of the tags of the hooks with the ones of the trays during the evisceration stage

In the second use case (recording the association of tags of the hooks with the ones of the trays during evisceration stage), an antenna (antenna # 0) positioned at the top,

next to the conveyor belt, records the passage of hook tags at the entrance of the evisceration stage.

Another antenna (antenna # 1), located near the trays, also records the passage of the tags of the trays. The two antennas send this information in a synchronized way to the reader of this stage, which informs the Fosstrak middleware. The middleware, in turn, filters and sends the synchronized information to the client application, which records its entry in the evisceration stage (Figure 8).

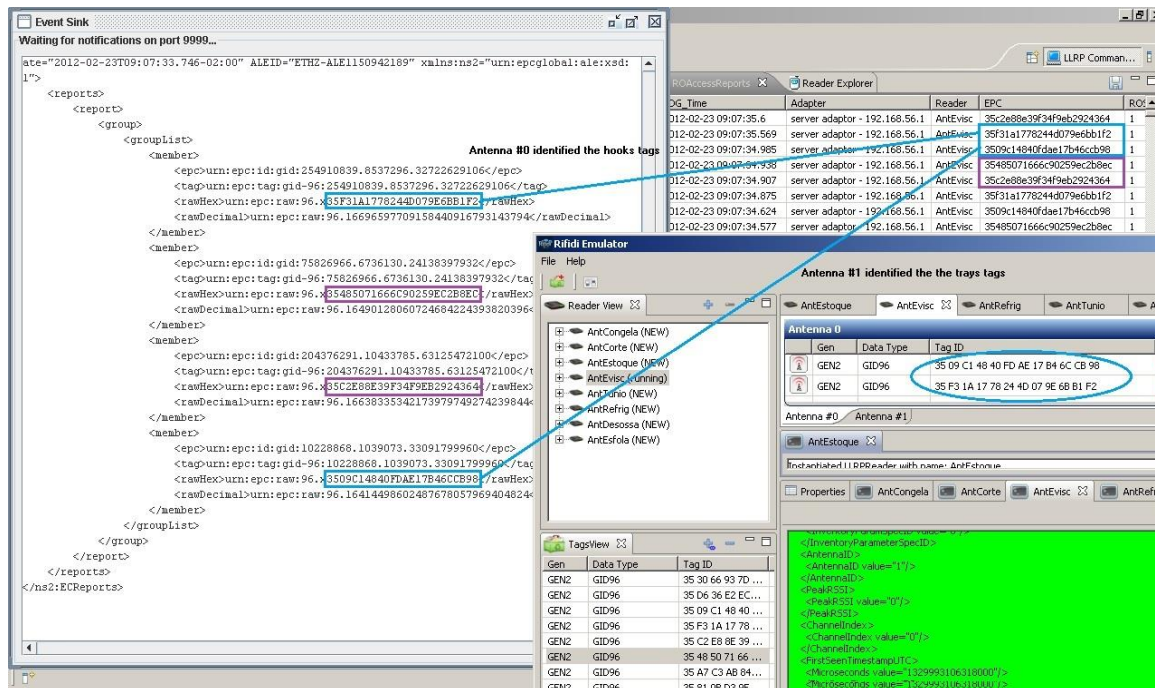

Figure 8 - Identification of trays (Antenna #1) during evisceration.

As an example, if a package contains offal of two animals, and knowing that there are two trays and two hooks for each animal, there are four hooks and four trays at this stage. In the first and third trays the edible offal are dumped and in the second and fourth trays, the intestines and stomachs are dumped. In this case, the last two ones are ignored by the system. The offal of the two animals are bagged together, which makes impossible to track the specific animal from which the offal originated.

There are only two trays remaining to be recorded by the client application. Not tagging those trays is one option to avoid extra expenses with the tags of the trays that are going to be discarded is. Instead, a visual identification in the labeled trays such as a brand, or a different color could be made. With this identification the employees of this stage know that it is in that tray where the offal must be dumped.

According to this proposal there are two tags, one for each hook and a tag for the tray with the offal. Once the second tray is identified, a new tag is generated with data of the two animals to be attached to the package. This package, with this EPC code, can be tracked at any post-slaughterhouse point until its final destination. Through this code the two animals that generated the offal packet can be reached.

It is not possible to associate the product to an animal, because in the production process of the slaughterhouse under this study, the edible offal are not wrapped up individually. Edible offal are placed in a bag and then packed.

4.3. Use case 3 - recording the association of the tags of the hooks with the one of the conveyor belt during the deboning stage

In the third use case, in which there is the record of the association of the tags of the hooks with the one of the conveyor belt during deboning, there is a major concern point. The quarter (half carcass in two parts) that enters this phase must be identified by the reader at the entrance of the conveyor belt. It is supposed that the quarter goes through the conveyor belt being cut into pieces until only the bones remain, and its parts are packed one by one into separate bags, and placed into packages. These packages contain a certain number of pieces of several animals. Next, a situation where it is possible to use RFID for traceability part of an animal is presented.

The simulation made by the Rifi Emulator in this stage (Figure 9) is simple, as the tag must be identified one by one. What is important is to know the package size and the size of each animal part, and only then it is possible to identify how many parts each package holds. These data must be informed by the production manager and added to the data provided by the scale at each point in the client application packaging.

Another important point is the quantity of parts per animal quarter. With the information of the package capacity, one can make a prediction of how many quarters are needed to fill each package.

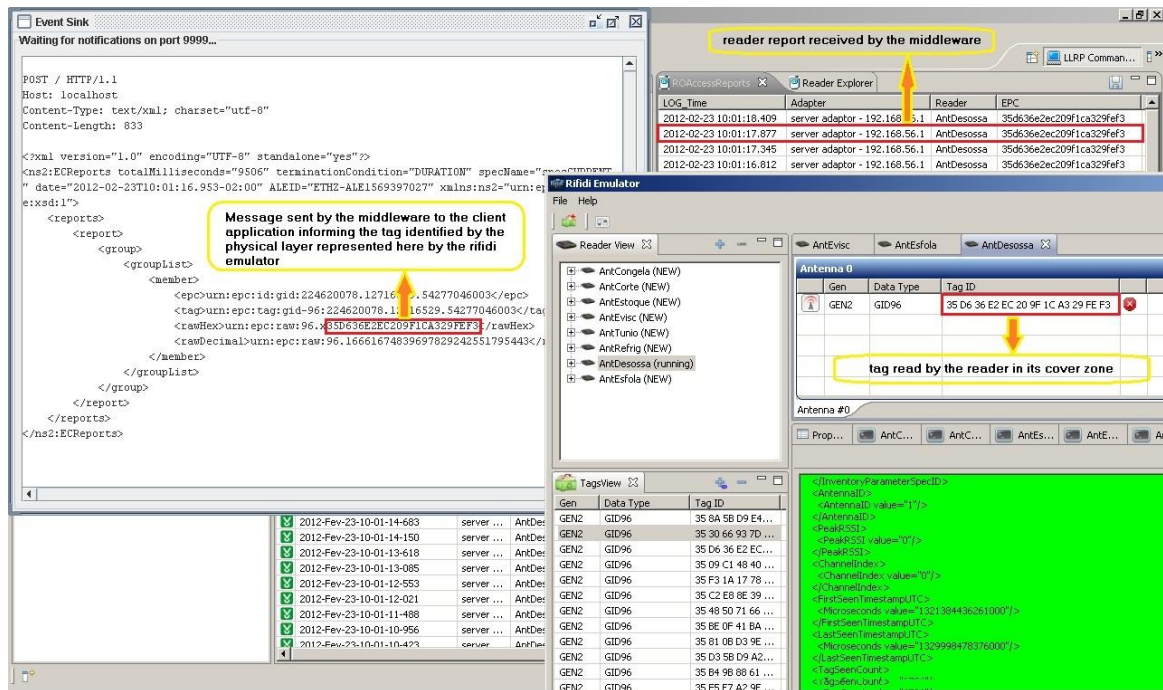

Figure 9 - Identification of the hooks on deboning stage.

According to the information provided for this environment, it is possible to have a solution in which a reader positioned on top of the conveyor belt reads the tag of the hook, transferring it to the Fosstrak middleware, forwarding it to the system where the animal is identified.

As the parts of this animal are being packed, the system records it up to the point that the package is filled up with parts of the same type. Finally, a tag is generated with information from the animals that originated the parts of the package.

5. CONCLUSIONS

The traceability of products of bovine animals within the production process of a slaughterhouse, despite being compromised by the specificity of its process, has demonstrated its technical feasibility. Although RFID technology is not in itself enough to guarantee the traceability of the animal until the last link in the chain of beef production, this traceability can be ensured through a methodology that involves the positioning of readers in strategic places such as labels on hooks and trays, and labels on packages with all information from the animals they are originated, for inventory and shipping control.

The labels of the hooks and trays can be passive and contain the code that identifies the EPC. In order to know in which phase of the production process the animal is, readers installed at strategic locations identify the tag in its coverage area, and send this information to the middleware connected to them, which forwards this information in a filtered and aggregated style to the client application.

The use of a simulator such as the Rifidi Emulator to represent use cases of a slaughterhouse was presented as an option for achieving this crucial work, because without it would be impossible to implement this technology in a test environment. The simulation results of the use cases presented ensure the possibility of implementation of RFID in the production process of a slaughterhouse, being one of its benefits to guarantee the continuity of the traceability of beef products (quarters, parts) and the origin of offal in each package.

The RFID system, which consisted of tags placed on hooks and trays plus the readers located at the beginning of each stage in conjunction with the client application to the database well-structured in this study, can keep the identity of the animal in its end products, even when faced with the dismemberment of its parts and aggregation of products of the same type to generate packages.

The benefits acquired are not limited to animal traceability lost at slaughter in the current structure, but also in inventory control, agility in the area of product shipment, logistics control, transparency in the production and handling of products among others.

6. LIMITATIONS

In this work some strengths and weaknesses in the use of Fosstrak middleware, Rifidi Emulator and the traceability chain of beef were identified. The strengths are: Fosstrak middleware communicates seamlessly with the Rifidi Emulator; both do not require large computers (personal or notebook). Medium and small computers meet their implementation needs; the Rifidi Emulator is easy to install and use; the Rifidi Emulator has no limit to create tags or readers.

The weaknesses are: the Fosstrak middleware has difficulty forwarding this information to the client(s) application(s); Fosstrak middleware is difficult to install and use; Fosstrak middleware communicates with a reader by turns, the Rifidi Emulator is limited to configuration capabilities, for instance, placing the tag in the coverage area of the antenna is only done manually, both the Rifidi Emulator and the Fosstrak middleware have limitations in the Windows operating system (Windows7 operating system was employed in this work).

REFERENCES

- ABIEC - ASSOCIAÇÃO BRASILEIRA DAS INDÚSTRIAS DE CARNES – Exportações Brasileiras de Carne Bovina, 2011. Disponível em: <<http://www.brazilianbeef.org.br/>>. Acesso em: 21 de fev 2012.
- Bernstein, P. A. (1996). Middleware: a model for distributed system services. Communications of the ACM, New York, v. 39, n.2.
- BRASIL - MINISTÉRIO DA AGRICULTURA, PECUÁRIA E ABASTECIMENTO. Regulamento da Inspeção Industrial e Sanitária de Produtos de Origem Animal, RIISPOA e outras legislações de interesse do DIPOA/SDA. Lei no 1.283, de 18 de dezembro de 1950. Brasília-DF, 2007.
- _____ - MINISTÉRIO DA AGRICULTURA, PECUÁRIA E ABASTECIMENTO. Intercâmbio comercial do agronegócio: principais mercados de destino / Ministério da Agricultura e Abastecimento. Secretaria de Relações Internacionais do Agronegócio. – Brasília: Mapa/ACS, 2011.
- Campanhola , C. (2005) Avanços na pesquisa agropecuária brasileira. Revista USP , n.64, p. 68-75.
- Carvalho , M. A. & Silva, C. R. L. da. (2005). Vulnerabilidade do comércio agrícola brasileiro. Revista de Economia e Sociologia Rural, v.43, n.1, p. 9-28.
- Cocaro , H. & JESUS, J. C. dos S. (2007). Impactos da implantação da rastreabilidade bovina em empresas rurais informatizadas: estudos de caso. Journal Of Information Systems And Technology Managemen, v.4, n.3, p. 353-374.
- Cortesi , M. L. (1994). Slaughterhouses and humane treatment. Scientific and Technical Review of the Office International des Epizooties, v.13, n.1, p.171-193.
- Costa , E. G. da. (2010). Análise da utilização de Tecnologias da Informação Móveis e Sem Fio (TIMS) nos diferentes elos da cadeia bovina do Estado de Goiás. Dissertação de M.Sc, Universidade do Vale do Rio dos Sinos – RS, Brasil.
- Finkenzeller, K. (2003). RFID Handhbook: Fundamentals and Applications in Contactless Smart Cards and Identification. John Wiley & Sons, 2º edição.
- Floerkemeier , C; Koduner, C. & Lampe, M. (2007). Application Development with the Accada Middleware Platform. IEEE System Journal, v. 1, n. 2.
- Fosstrak. Fosstrak: open source RFID platform, 2012. Disponível em: <<http://www.fosstrak.org>>. Acesso em: 01 de abr 2011.
- Glover, B. & Bhatt, H. (2007). Fundamentos de RFID. Rio de Janeiro: Alta Books.
- Grumovski , D. (2009). Sistema de Gerenciamento de Dados Coletados pela Tecnologia RFID, E-Tech: Tecnologias para Competitividade Industrial, Florianópolis, v. 2, n. 2, p. 14-37.
- IBGE - INSTITUTO BRASILEIRO DE GEOGRAFIA E ESTATÍSTICA – Indicadores IBGE – Estatística da Produção Pecuária, 2010. Disponível em: <<http://www.ibge.gov.br/home/download/estatistica.shtm>>. Acesso em: 01 abr 2011, 09:08:30.

- Krajewski, L.; Ritzman, L. & Malhotra, M. (2009). *Administração de Produção e Operações*. Pearson Education do Brasil.
- Miguel, P. A. C. (org.) (2010). *Metodologia de Pesquisa em Engenharia de Produção e Gestão de Operações*. Elsevier, Rio de Janeiro.
- Nogueira, F. C. C. da C. (2005). *Tecnologia RFID aplicada à Logística*. Tese de M.Sc, Pontifícia Universidade Católica do Rio de Janeiro, Rio de Janeiro.
- RIFIDI. Rifidi – Software Defined RFID. Disponível em <<http://www.rifidi.org>>, 2012. Acesso em: 09 maio 2011.
- Roça, R.O. (1999). *Abate humanitário: o ritual kasher e os métodos de insensibilização de bovinos*. Botucatu: FCA/UNESP. Tese (Livre-docência em Tecnologia dos Produtos de Origem Animal) - Universidade Estadual Paulista.
- Santini, A. G., (2008). *RFID: Conceitos, Aplicabilidades e Impactos*, Editora Ciência Moderna, Rio de Janeiro.
- Schuster E. W.; Allen S.J.; Brock D.L. (2007). *Global RFID: the value of the EPCglobal network for supply chain management*. Springer-Verlag. New York.
- Steiner, H. (1983). Working model of standardized technique for the hygienic slaughtering of cattle. *Fleischwirtschaft*, Frankfurt, v.63, n.7, p.1186-1187.
- Thornton, H. (1969). *Compêndio de inspeção de carnes*. Londres: Bailliere Tindall an Cassel, p.665.
- Traub, K.; Armenio, F.; Barthel, H. & al. (2010). *The EPCglobal Architecture Framework*.

