

Nanocrystalline Silicon based Metal-oxide-semiconductor Cathodes

著者	SHIMAWAKI Hidetaka
著者別名	嶋脇 秀隆
journal or publication title	The bulletin of Reseach Institute for Interdisciplinary Science, Hachinohe Institute of Technology
volume	7
page range	1-4
URL	http://id.nii.ac.jp/1078/00002326/

Nanocrystalline Silicon based Metal-oxide-semiconductor Cathodes

Hidetaka SHIMAWAKI*

Abstract

Metal-oxide-semiconductor (MOS) cathodes with an array structure have been fabricated based on nanocrystalline silicon covered with a thin oxide film prepared by a pulsed laser ablation technique and their emission properties have been investigated. The electron emission occurred at the gate voltage higher than the work function of the Au gate, and the emission efficiency reached about 2% at the gate voltage of 25 V. Although the current decreased slightly, it was relatively stable. We also observed the emission image on the phosphor screen and the emission divergence was estimated to be less than 3°.

Key words: nanocrystalline silicon, electron emission, MOS, tunneling cathode

1. Introduction

A metal-oxide-semiconductor (MOS) cathode is a promising candidate as a fine electron source for applications of vacuum nanoelectronic devices, because the cathode operates at low extraction voltage, and produces uniform and highly directional emission. Furthermore, the cathode is insensitive to environment. However, the device is limited in emission current by its low efficiency of less than 1% due to the strong phonon-electron scattering in both the oxide layer and the gate electrode during traveling through the conduction band of the oxide and the gate electrode. In fact, a considerable increase in emission current has been measured and a large number of electrons have been detected at the energies lower than the original work function of the gate electrode by cesiation^[1]. Lowering the work function of the gate electrode is a practical way for improving the emission current, i.e., the emission efficiency. Recently, the modified MOS cathodes have reported high emission efficiencies over 10%, where the oxide layer is replaced with semi-insulating layers such as non-doped Si, SiO_x films, or nanocrystalline Si consisting of oxidized porous Si and poly-Si^[2-5]. Although the mechanism is not still understood, the use of films containing nanocrystalline structures taking the place of the oxide layer is a promising way to improve the performance on the MOS cathode.

In a previous paper^[6], we have reported the emission characteristics of MOS cathodes based on nanocrystalline Si (nc-Si) prepared by a pulsed laser

ablation (PLA) technique. This technique has the advantage of fabricating nanocrystalline Si covered with a thin oxide layer in contrast to other fabrication methods. It was demonstrated electron emission at the gate voltage as low as the work function of the gate metal and the high emission efficiency of 4% by reducing the thickness of the Au gate metal. However, the energy of emitted electrons was widely distributed and showed strong dependence on the applied gate voltage. A lot of nanoholes in the thin Au film were observed, suggesting emission includes electrons tunneled through thin metal and directly emitted from nanotips aligned under nanoholes observed in metal.

In this work, we investigate the emission characteristics of an nc-Si MOS cathode array for emission with a narrow spread of electron energy.

2. Experiments

Figures 1 (a) and (b) show a schematic structure of an nc-Si planar cathode and its fabrication process, respectively. The device is a thin film diode structure, which consists of nanocrystalline silicon (nc-Si) particles covered with an oxide film on an n-type silicon substrate as an electron source and a thin top metal electrode as an extraction gate. The emission area of the device is set an array pattern of 50 μm -diametric circles in an area of 500 μm in diameter. The nc-Si layer was deposited by a pulsed laser ablation technique using a Si disc target, which was irradiated with the fourth harmonic ($\lambda = 266 \text{ nm}$) of Nd: YAG laser (Spectron, SL856) light with an energy of about 80 mJ/cm^2 , a pulse width of 13 ns and a repetition rate of 10 Hz. To create the tunneling

平成 21 年 1 月 7 日受理

* 異分野融合科学研究所/大学院工学研究科電子電気・情報工学専攻・准教授

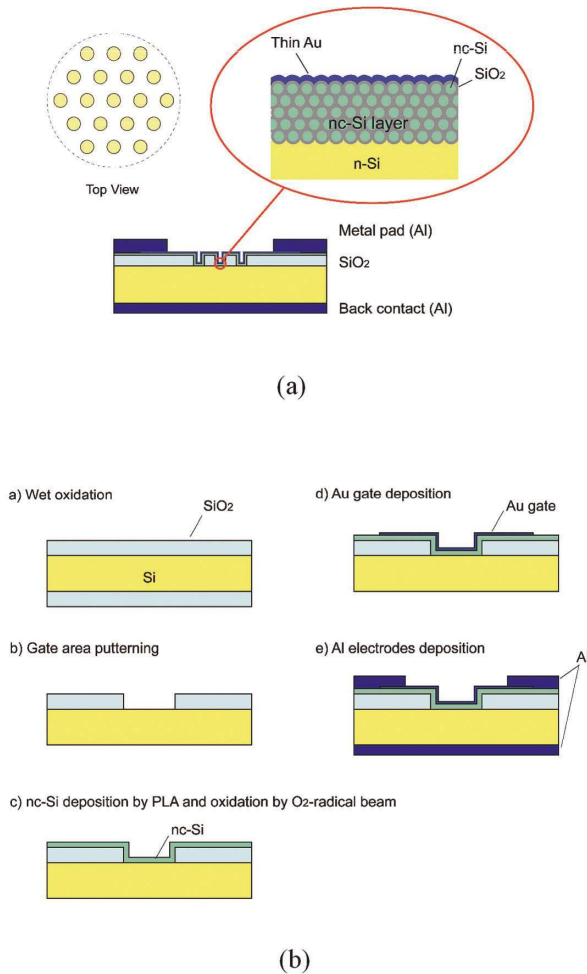

Fig. 1 Schematics of nc-Si MOS cathode array (a), and its fabrication process (b).

barrier in the interface between nc-Si particles, surfaces of nc-Si particles were oxidized by an oxygen

radical beam exposure during deposition, which was generated by radio frequency discharge with the RF power range of 250 to 350 W at the pressure of 5×10^{-5} Pa. The substrate temperature was kept at 450°C during deposition. Although we could not estimate the thickness of the thin oxide layer covering the surface of nc-Si, the oxide layer will play as the tunneling barrier in the interface between nc-Si particles. After rapid thermal oxidation at 700°C for 1 hour was adopted for forming a thin oxide layer near the top surface, a thin Au layer for the gate electrode was formed by sputter deposition. Finally, Al electrodes were evaporated on a part of the Au film to reduce the resistance and the backside of the substrate to form an ohmic contact.

We measured the emission characteristics and the energy distribution of emitted electrons by the experimental setup using a Faraday cup analyzer with double-meshes and a collector illustrated in Fig. 2. In the experiments, we defined the gate current measured at the gate electrode as a diode current, and the anode current measured at the first mesh as an emission current. We also observed the emission image on a phosphor screen.

3. Results and discussion

Figure 3 shows typical diode and emission currents of the cathode array, and emission efficiency, which are defined as the ratio of the emission current to the total current. Electron emission occurs at nearly 6 V,

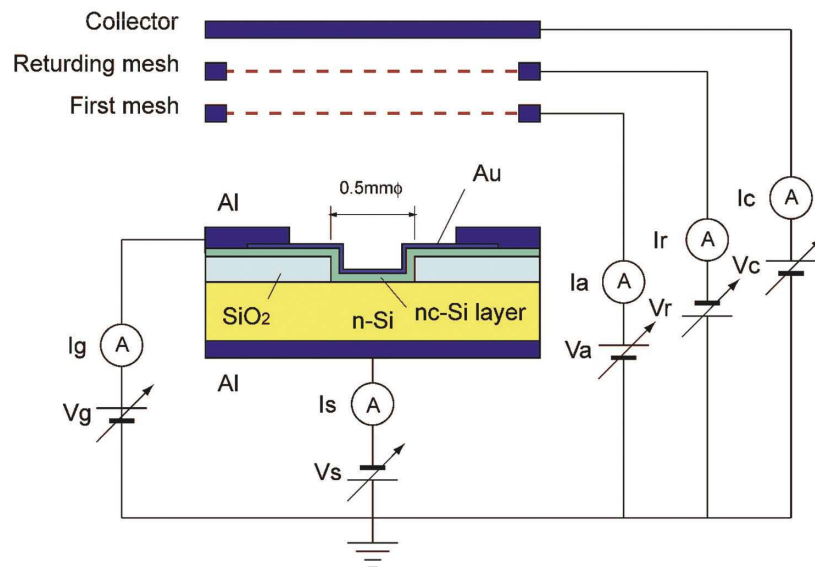

Fig. 2 Measurement setup of emission characteristics.

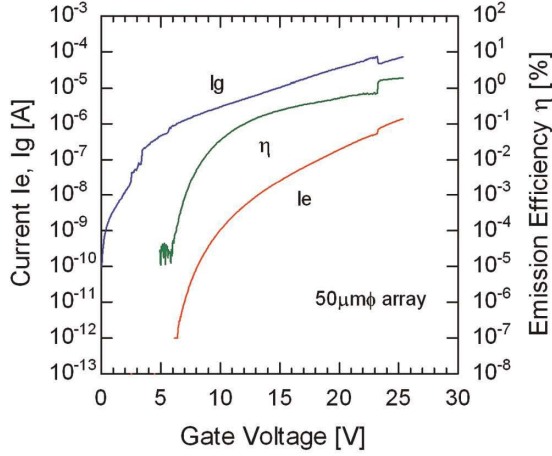

Fig. 3 Emission characteristics of an nc-Si MOS cathode array.

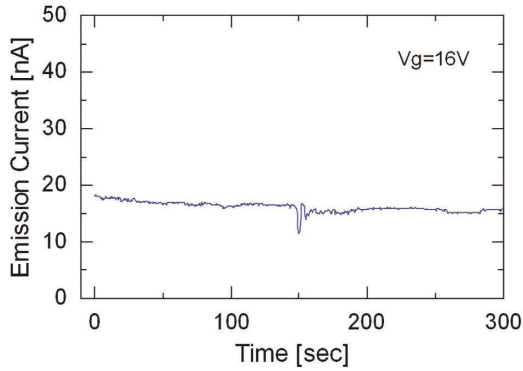

Fig. 4 Time dependence of the emission current of an nc-Si MOS cathode array.

which is as low as the work function of the Au gate electrode and the emission current rises rapidly with increasing gate voltage. Current saturation, which was observed previously^[6], does not occur at high fields. The emission efficiency reaches about 2% at the gate voltage of 25 V. The time dependence of the emission current for a constant gate voltage is shown in Fig. 4 at the pressure of 5×10^{-6} Pa. Although the current decreases slightly, it is relatively stable.

We have measured the energy distribution of emitted electrons from the cathode array using a Faraday cup analyzer with double-meshes and a collector. Figure 5 shows the energy spectra of emitted electrons from the cathode array at several gate voltages, which are normalized by each total emission current. The zero energy in the abscissa indicates the vacuum level of the Au gate electrode. FWHM of the spectrum becomes broader and maximum energy moves to higher value with increasing gate voltage. However, the change is not significant compared with that for the cathode without the arrayed structure report-

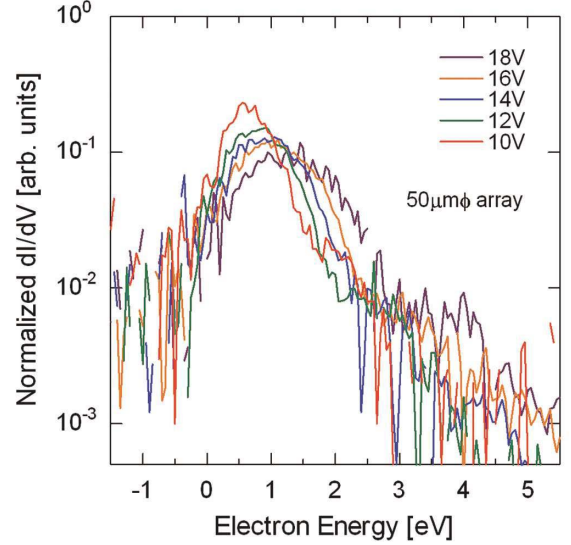

Fig. 5 Energy spectra of emitted electrons from an nc-Si MOS cathode array at various gate voltage.

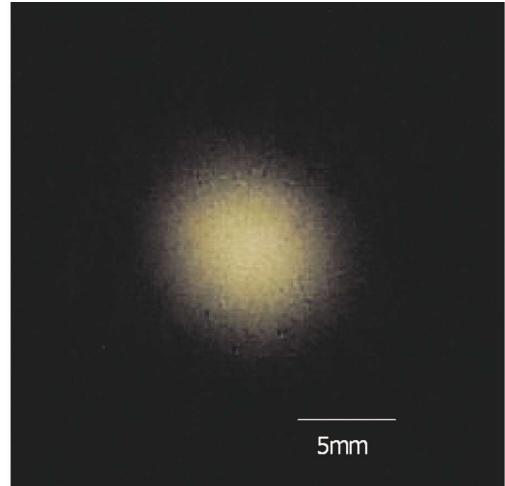

Fig. 6 Emission image from the nc-Si MOS cathode array.

ed previously^[6] and the threshold energy of emitted electrons remains almost the same at near the work function of the gate metal, in contrast to the previous results^[6]. This indicates that the energy distribution of the emitted electrons does not increase even with increasing gate voltage, because the field emission component through nanoholes in the metal gate decreases due to the arrayed structure.

Figure 6 shows the emission image observed on the phosphor screen. The screen was located at 40 mm above the cathode array and biased at the acceleration voltage of 5 kV. The emission divergence is estimated to be about 3° . This value is smaller than that of the cathode without the arrayed structure, suggesting that uniformity of the field in the emission

area is improved for the arrayed cathode.

4. Conclusion

We fabricated nanocrystalline silicon based MOS cathode arrays with thin gate metals, and examined their emission characteristics and energy distributions to improve the performance of the MOS cathode and understand the emission mechanism of nanocrystalline based cathodes. The emission efficiency was improved by reducing the thickness of the gate metal. The use of films containing nanocrystalline structures taking the place of the oxide layer is a promising way to improve the performance on the MOS cathode.

Acknowledgements

A part of this work was carried out in the Laboratory for Nanoelectronics and Spintronics of the Research Institute of Electrical Communication, Tohoku University. This work was supported in part

by a Grand-in-Aid for Scientific Research from Japan Society for the Promotion of Science in Japan and the nationwide cooperative research projects organizing by RICE, Tohoku University.

References

- [1] H. Mimura, Y. Neo, H. Shimawaki, Y. Abe, K. Tahara, and K. Yokoo, *Appl. Phys. Lett.* 88, 123514 (2006).
- [2] K. Yokoo, G. Koshita, S. Hanzawa, Y. Abe, and Y. Neo, *J. Vac. Sci. Technol.* B14, 2096 (1996).
- [3] X. Sheng, H. Koyama, and N. Koshida, *J. Vac. Sci. Technol.* B16, 793 (1998).
- [4] N. Negishi, T. Chuman, S. Iwasaki, T. Yoshikawa, H. Ito, and K. Ogasawara, *Jpn. J. Appl. Phys., Part 2*, 36, L939 (1997).
- [5] A. Govyadinov, T. Novet, D. Pidwerbecki, S. Ramamoorthi, J. Smith, J. Chen, C. Otis, D. Neiman, and P. Benning, *J. Vac. Sci. Technol.* B23, 853 (2005).
- [6] H. Shimawaki, Y. Neo, H. Mimura, K. Murakami, F. Wakaya, and M. Takai, *J. Vac. Sci. Technol.* B26, 864 (2008).
- [7] H. Shimawaki, Y. Neo, and H. Mimura, *J. Vac. Sci. Technol.* B24, 971 (2006).