

## The Analytic Hierarchy Process: A Tutorial for Use in Prioritizing Forest Road Investments to Minimize Environmental Effects

Elizabeth Dodson Coulter  
*University of Montana*  
*Montana, USA*

James Coakley  
John Sessions  
*Oregon State University*  
*Oregon, USA*

### ABSTRACT

The prioritization of road maintenance projects is an important forest engineering task due to limited budgets and competing investment needs. Large investments are made each year to maintain and upgrade forest road networks to meet economic and environmental goals. Many models and guidelines are available for single-criteria analysis of forest roads, however we have found no method for multi-criteria analysis. Additionally, even single criteria approaches often rely on expert judgment to inform models of user preferences and priorities. These preferences are used to make tradeoffs between alternatives that contain data that are physical and biological, quantitative and qualitative, and measured on many different scales. The Analytic Hierarchy Process (AHP) has the potential to provide a consistent approach to the ranking of forest road investments based on multiple criteria. AHP was specifically developed to provide a consistent, quantifiable approach to problems involving multi-criteria analysis, but it has not been applied to road management. AHP is composed of four steps: the hierarchical decomposition of a problem into a goal, objectives, and sub-objectives; the use of a pairwise comparison technique to determine user preferences; the scaling of attribute values for each of the alternatives; and the ranking of alternatives. The road investment problem differs from traditional AHP applications in that potentially thousands of alternatives are compared at one time. We discuss the AHP methodology including the foundations, assumptions, and potential for use in prioritizing forest road investments to meet economic and environmental goals, drawing from an example

*The authors are, respectively, Assistant Professor of Integrated Natural Resource Planning, University of Montana, Missoula, MT; Professor and Associate Dean, College of Business, Oregon State University, Corvallis, OR; and Distinguished Professor of Forest Engineering, Oregon State University, Corvallis, OR.*

from the Oregon State University College Forests.

**Keywords:** *Analytic Hierarchy Process, low volume roads, forest roads, road maintenance.*

### INTRODUCTION

Each year, large sums of money are spent to upgrade and maintain networks of forest roads. One of the primary tasks in the management of any forest road network is to set investment priorities. This is currently done in an ad hoc, often reactionary fashion as new laws, policies, and preferences arise. Models and methods have been developed to deal with individual aspects of forest roads, such as sedimentation [7] and fish passage [27], but currently there are few comprehensive frameworks available to managers to aid in setting priorities on a system-wide, multi-criteria basis. The Analytic Hierarchy Process (AHP) has potential for filling this gap.

Many land management agencies and companies have undertaken inventories of their forest roads. Publications such as “Roads Analysis: Informing Decisions About Managing the National Forest Transportation System” [35] help decision makers decide on attributes of concern, but give little direction in how these attributes should be combined and analyzed. This has led to the prevalence of informal decision methods to set investment priorities. While these approaches are able to capture expert judgment, there is no way of ensuring this judgment is applied consistently.

Many modeling approaches used in forest engineering rely on expert opinion and professional judgment to inform models of user priorities that are used to make tradeoffs between alternatives. Often these alternatives contain physical and biological, quantitative and qualitative data that are measured on many different scales. Expert judgment is necessary in cases where science has not determined quantifiable relationships between cause and effect. Multi-Criterion Decision Analysis (MCDA) is a field of theory that analyzes problems based on a number of criteria or attributes.

A number of MCDA methods exist in the literature. While these methods differ in a number of ways, the primary difference is how each elicits preferences from decision makers. Weighting techniques range from fixed point scoring and rating to ordinal ranking and pairwise comparisons [11]. Techniques such as the ELCTRE methods [28] produce a set of non-dominated alternatives through a process of outranking. Methods relying on ordinal judgments and outranking, however, will often not be able to produce a single best alternative [17, 24].

The Ecosystem Management Decision Support (EMDS) program developed by the USDA Forest Service uses Netweaver [25] to evaluate potential environmental impacts of land management decisions using fuzzy logic. This process requires decision makers to develop fuzzy truth curves for each element included in an analysis. EMDS and Netweaver have been applied to an analysis of forest roads on the Tahoe National Forest [10].

Some MDCA techniques require decision makers to set parameter weights and coefficients, such as goal programming and nonlinear optimization. The major drawback to these techniques is that weights placed on individual attributes (for example acres harvested, tons of sediment, and dollars of net present value) are required to serve two purposes. First, the weight must make the variables measured on different scales comparable, and second, the weight is used to adjust the relative importance of each variable to the problem. The contribution of the weight to each of these purposes cannot be separated from the total value of the weight being used.

An alternative MCDA technique called the Analytic Hierarchy Process, or AHP, is presented here. Quoting Harker and Vargas [12], “AHP is a comprehensive framework which is designed to cope with the intuitive, the rational, and the irrational when we make multiobjective, multicriterion and multiactor decisions with and without certainty for any number of alternatives.”

When considering the forest road investment problem, models and guidelines exist for single-problem analysis such as road-related sediment or fish passage. However, when a decision maker needs to prioritize investments based on multiple problems the task becomes more difficult. For example, science has not produced quantifiable relationships to guide tradeoffs between road-related sediment production and road-related landslides. Thus the problem of setting priorities when presented with a road inventory is left to professional judgment. AHP is a framework for ensuring this judgment is applied consistently to all alternatives within a replicable, mathematically justifiable framework. Additionally AHP has been chosen as an appropriate tool for analyzing forest road networks because it 1) is flexible and can be easily adapted to unique analysis situations; 2) requires no special software to implement; and 3) can be understood by a lay audience.

The traditional use of AHP is to rank a small number of alternatives. The road investment problem differs from these traditional problems in that a single analysis may include a large number of alternatives in the form of individual road segments or road features. We first discuss the AHP methodology, including the foundations and assumptions, and then formulate and solve a forest road investment problem.

## THE ANALYTIC HIERARCHY PROCESS

The AHP involves the following four basic steps:

- Structuring the problem as a hierarchy;
- Completion of pairwise comparisons between attributes to determine user preference;
- Scaling of attributes; and
- Ranking of alternatives.

### Step 1: Structure the Problem as a Hierarchy

The hierarchy is a basic structure used intuitively by decision makers to decompose a complex problem into its most basic elements, a process referred to as hierarchical decomposition [23]. The top level of the hierarchy is the overall goal for the analysis (Figure 1). This goal is important in framing and focusing the problem. For example, if we are using AHP to determine the “best” forest road investments to make, we could use any of the following goals:

- Minimize environmental impacts of forest roads;
- Minimize impacts of forest roads on endangered runs of fish;
- Improve salmon habitat through upgrades in the forest road network; or
- Minimize transportation costs associated with forest roads.

While all of these are legitimate goals, each will require a different analysis and produce a different outcome.

The second level of the hierarchy breaks the goal down into objectives. If the goal is to “minimize environmental impacts of forest roads,” the second level in the hierarchy may contain the following objectives:

- Minimize sediment reaching waterways,
- Minimize the incidence of road-related landslides, and
- Minimize direct impacts to aquatic habitat.

The third and subsequent levels of the hierarchy further decompose the objectives into increasingly more specific sub-objectives.

Another way to look at the hierarchy is as a visual representation of an objective function where each objective is a function of its sub-objectives. This process of decomposition continues to successive layers of the hierarchy as far as is necessary to adequately represent the problem. It is not required that each objective be decomposed the same number of levels.

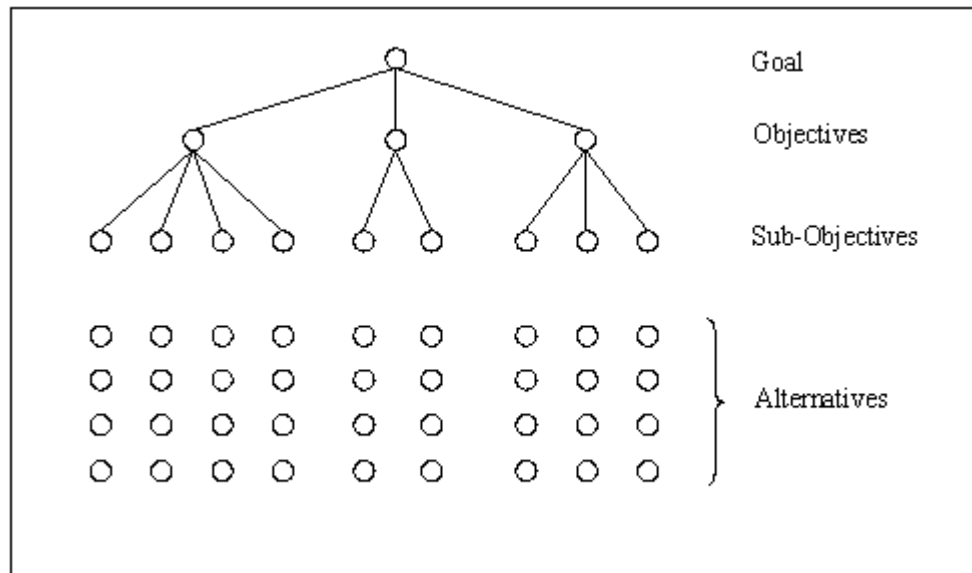

Figure 1. Generalized hierarchy depicting an overall goal, three objectives, and nine sub-objectives. Alternatives are not part of the problem hierarchy but have attributes that correspond to the elements in the lowest level of the hierarchy.

Below the hierarchy reside the alternatives to be considered. For our example these alternatives would be potential investments in a forest road network. Each alternative would have attributes that correspond to the criteria or sub-criteria at the lowest level of the hierarchy.

A hierarchy is termed complete if every element in each level connects to every element in both the layer above and below. The hierarchy shown in Figure 2b is an incomplete hierarchy because each sub-objective (third layer) is not relevant to each and every objective (second layer). The choice of a complete or an incomplete hierarchy depends on the independence of the individual elements. For example, consider two problem formulations where the overall goal is to choose restoration projects that will provide the most benefit to salmon habitat (Figure 2). In each of these formulations, the overall goal is subdivided into three objectives, or types of investments to be considered: investments associated with forest roads, investments related to silvicultural activities, and investments involving in-stream restoration. The bottom level of the hierarchy contains the attributes upon which the individual investments will be judged. For this example, let us consider only one of these factors: sediment.

While both formulations consider the same factor, sediment, in the first (Figure 2a) the worth of sediment in re-

storing fish habitat is independent of the source of sediment. In the second example (Figure 2b) the influence of sediment on the goal of restoring fish habitat would be dependent on its source, allowing the decision maker to treat sediment from roads differently from the sediment created through silvicultural activities or sediment that may already reside in a stream. The choice of hierarchical structure should follow the dependence or independence of the problem.

A classic psychological study conducted by Miller [21] showed that the average individual has the capacity to keep only seven, plus or minus two, objects in mind at any one time without becoming confused. Therefore Saaty [29] recommends that for each branch at each level of the hierarchy, no more than seven items be compared. For larger problems, this may mean that similar elements will need to be grouped and additional layers of hierarchy added in order to keep the problem formulation manageable.

This completes the first step of AHP. A hierarchical decomposition process is used to structure the goal as a hierarchy of objectives and sub-objectives. We now proceed to the second step which employs a pairwise comparison technique to derive the relative value of each objective and sub-objective.

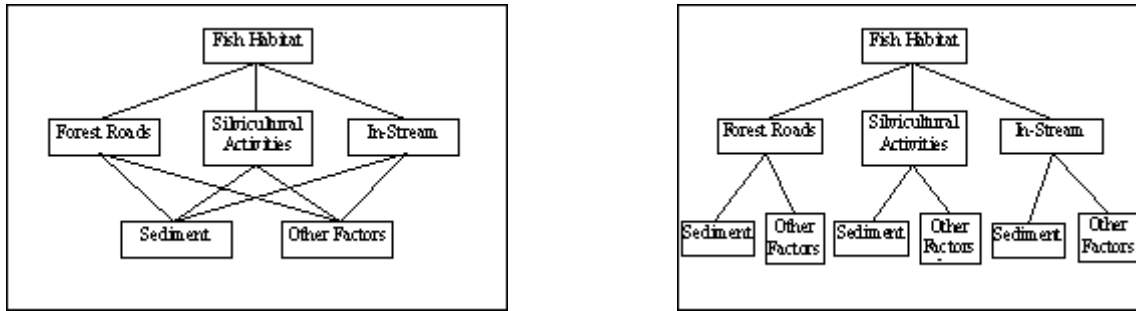

Figure 2. a (left) Complete and independent problem formulation where the importance of sediment is independent of the sediment source. b (right) Incomplete and dependent problem formulation where the importance of sediment is dependent on the sediment source.

### Step 2: Pairwise Comparisons

In order to determine the relative importance of each objective and sub-objective, a pairwise comparison technique is used. Comparisons are performed between pairs of elements within each branch of each level of the hierarchy to determine the relative worth of one element as compared with another in relation to the element directly above. For example, a question that may be asked of a decision maker is “How much more important is sediment volume produced by the road than the distance between a road and the stream in predicting the volume of road-related sediment entering a stream?” The pairwise comparisons from each branch at each level of the hierarchy are entered into a matrix and used to determine a vector of priority weights. Only those elements that pertain to a common objective are compared against one another.

We use the following notation:

- $w_i$  = weight for attribute  $i$ ,  $i=1, \dots, n$  where  $n$  = number of attributes
- $a_{ij}$  =  $w_i / w_j$  = the result of a pairwise comparison between attribute  $i$  as compared to attribute  $j$
- $A$  = matrix of pairwise comparison values,  $a_{ij}$

A set of pairwise comparisons can be represented as:

$$A = \begin{bmatrix} w_1/w_1 & w_1/w_2 & \dots & w_1/w_n \\ w_2/w_1 & w_2/w_2 & \dots & w_2/w_n \\ \vdots & \vdots & \ddots & \vdots \\ w_n/w_1 & w_n/w_2 & \dots & w_n/w_n \end{bmatrix} \quad (1)$$

where  $w_1/w_2$  is the importance of attribute 1 as compared to attribute 2. Since the direct result of a pairwise comparison is  $a_{ij}$ , where  $a_{12}$  is equal to  $w_1/w_2$ , matrix A becomes:

$$A = \begin{bmatrix} a_{11} & a_{12} & \dots & a_{1n} \\ a_{21} & a_{22} & \dots & a_{2n} \\ \vdots & \vdots & \ddots & \vdots \\ a_{n1} & a_{n2} & \dots & a_{nn} \end{bmatrix} \quad (2)$$

The goal of AHP is to uncover the underlying scale of priority values  $w_i$ . In other words, given  $a_{ij}$ , find the “true” values of  $w_i$  and  $w_j$ .

This A matrix has some special properties. First, A is of rank one. If we look at each column of A, we have:

$$A = \left\{ w_1^{-1} \begin{bmatrix} w_1 \\ w_2 \\ \vdots \\ w_n \end{bmatrix}, w_2^{-1} \begin{bmatrix} w_1 \\ w_2 \\ \vdots \\ w_n \end{bmatrix}, \dots, w_n^{-1} \begin{bmatrix} w_1 \\ w_2 \\ \vdots \\ w_n \end{bmatrix} \right\} \quad (3)$$

Each column of A differs only by a multiplicative constant,  $w_i^{-1}$ . If the A matrix is consistent only one column is required to determine the underlying scale ( $w_1, \dots, w_n$ ). The same evaluation could be undertaken in a row-wise fashion with the same result.

Second, if B is  $x$  times more important than C, then it follows that C is  $1/x$  times as important as B. In other words,  $a_{ji}$  is the reciprocal of  $a_{ij}$  such that  $a_{ij} = 1/a_{ji}$ . This assumes the decision maker is consistent with respect to individual pairwise comparisons and is a fundamental assumption made by the AHP (see the section on Consistency below). With this assumption, matrix A is reduced to:

$$A = \begin{bmatrix} 1 & a_{12} & a_{13} & \cdots & a_{1n} \\ 1/a_{12} & 1 & a_{23} & \cdots & a_{2n} \\ 1/a_{13} & 1/a_{23} & 1 & \cdots & a_{3n} \\ \vdots & \vdots & \vdots & \ddots & \vdots \\ 1/a_{1n} & 1/a_{2n} & 1/a_{3n} & \cdots & 1 \end{bmatrix} \quad (4)$$

As seen in equation (4), the diagonals are equal to unity (i.e.  $w_i/w_i = 1$ ). The above reduction means that only  $\frac{n(n-1)}{2}$  pairwise comparisons need to be solicited from decision makers as compared with  $n^2$  total entries in the completed A matrix. If the assumption that the decision maker is consistent with respect to individual pairwise comparisons does not hold, in other words if  $a_{ij} \dots 1/a_{ji}$ , then  $(n^2 - n)$  pairwise comparisons would be required.

### Deriving Weights

Once pairwise comparisons have been elicited from the decision maker, the next step is to use this matrix to estimate the underlying scale of preferences. In other words, given  $a_{ij}$ , find  $w_i$  and  $w_j$ . Because of the “random” error inherent in human judgment, even professional judgment, it can not be expected the true values of  $w_i$  and  $w_j$  can be found. The user will need to be content instead with good estimates of  $w_i$  and  $w_j$  [9]. Several methods have been proposed to estimate weights from matrices of pairwise comparisons. The two most common methods of deriving attribute weights are the eigenvector and the logarithmic least squares methods.

It can be shown by algebraic manipulations of the pairwise definitions that attribute weights can be obtained by finding the eigenvector corresponding to the largest eigenvalue of the A matrix. The eigenvector method was originally proposed by Saaty [29] and is one of the most popular methods of calculating preferences from inconsistent matrices of pairwise comparisons. Equation (3) showed a consistent matrix of pairwise comparisons. When inconsistency is introduced into pairwise comparisons, more than one row or column of A is desired in order to derive a good estimate of the underlying scale of weights. The special structure of a square reciprocal matrix means that the eigenvectors can be found and the largest eigenvector can be normalized to form a vector of relative weights [9].

Elements of the eigenvector are normalized to sum to one as opposed to setting the largest element of the eigenvector equal to one. This is required in order to give the potential for equal weighting between branches of the hierarchy where the number of elements being compared may be different. This normalization ensures the weights within each branch of the hierarchy sum to one no matter the number of elements or the relationships between the elements of a branch. Assume a hierarchy with two branches with two and six sub-objectives, respectively. If the vector of weights were normalized such that the largest element is equal to one, the branch with six sub-objectives would be given more weight in total than the branch with only two sub-objectives. Likewise a branch where there is little preference for one element over another would be given a higher total weight over a branch with the same number of elements but with larger differences in preferences between the individual elements.

Following the definition of  $a_{ij} = w_i/w_j$  and  $a_{ji} = 1/a_{ij}$ :

$$a_{ij}a_{ji} = a_{ij} \frac{1}{a_{ij}} = a_{ij} \frac{1}{w_i/w_j} = a_{ij} \frac{w_j}{w_i} = 1 \quad (5)$$

It follows that in the consistent case:

$$\sum_{j=1}^n a_{ij} \frac{w_j}{w_i} = n \quad i = 1 \text{ to } n \quad (6)$$

or, stated another way, multiplying equation (6) through by  $w_i$ :

$$\sum_{j=1}^n a_{ij} w_j = n w_i \quad i = 1 \text{ to } n \quad (7)$$

These statements are equivalent to the matrix notation  $Aw = nw$ . If the goal is, given a positive reciprocal matrix A, to find  $w$ , the problem becomes  $(A - nI)w = 0$ , a classical eigenvector problem. This method for deriving a vector of weights from a positive reciprocal matrix of pairwise comparisons uses the largest eigenvector, also termed the principal right eigenvector, and its corresponding eigenvalue.

One way to understand what eigenvectors and eigenvalues are is the following:

$$Aw = \begin{bmatrix} a_{11} & a_{12} & \cdots & a_{1n} \\ a_{21} & a_{22} & \cdots & a_{2n} \\ \vdots & \vdots & \ddots & \vdots \\ a_{n1} & a_{n2} & \cdots & a_{nn} \end{bmatrix} \begin{bmatrix} w_1 \\ w_2 \\ \vdots \\ w_n \end{bmatrix} = \begin{bmatrix} \lambda_1 & 0 & \cdots & 0 \\ 0 & \lambda_2 & \cdots & 0 \\ \vdots & \vdots & \ddots & \vdots \\ 0 & 0 & \cdots & \lambda_n \end{bmatrix} \begin{bmatrix} w_1 \\ w_2 \\ \vdots \\ w_n \end{bmatrix} = \lambda_1 \begin{bmatrix} w_1 \\ w_2 \\ \vdots \\ w_n \end{bmatrix} \quad (8)$$



where  $n$ , the eigenvalue of  $A$  (in the consistent case  $\lambda_{\max}$  will equal  $n$ ), is a matrix with diagonal values of  $\lambda_{\max}$ , the components of the eigenvector of  $n$ , and zero elsewhere. In other words, the eigenvector of  $A$  is an equivalent, diagonalized form of  $A$ . The Perron-Frobenius Theorem ensures that the components of the principal right eigenvector of a positive square matrix are real and positive [1]. One relatively simple method for solving for the principal right eigenvector is the Power Method [13].

The other commonly used method for scaling a matrix of pairwise comparison data is the logarithmic least squares method (LLSM), first proposed by Crawford and Williams [6]. When pairwise comparisons are inconsistent,  $a_{ij} = (w_i/w_j)$  becomes  $a_{ij} = (w_i/w_j)(\varepsilon_{ij})$  where  $\varepsilon_{ij}$  is the error associated with inconsistent judgment. This relationship can also be expressed as:

$$\ln a_{ij} = \ln w_i - \ln w_j + \ln \varepsilon_{ij} \quad i = 1, 2, \dots, n; j > i \quad (9)$$

This assumes the distribution of  $\varepsilon_{ij}$  is reciprocal such that  $\varepsilon_{ij} = 1/\varepsilon_{ji}$  and lognormally distributed and leads to the minimization of the following equation [5]:

$$\sum_{i=1}^n \sum_{j>i}^n [\ln a_{ij} - (\ln w_i - \ln w_j)]^2 \quad (10)$$

Note that equation (10) is nearly identical to the standard minimization of the sum of squares used in least-squares regression. The goal of LLSM is similar: to find the vector of weights that is the shortest distance from multiple estimates provided by pairwise comparisons. Equation (10) can be simplified so that for each row of  $A$  the geometric row mean is calculated:

$$w_i = \left[ \prod_{j=1}^n a_{ij} \right]^{1/n} \quad (11)$$

Like the eigenvector method the vector of resulting values is normalized so that the elements sum to one.

While some have strong feelings for either the eigenvector or LLSM (see [5], [32], and [33]), others consider this an extra-mathematical decision to be made when implementing AHP [9]. In the consistent case or when three or fewer elements are being compared, both the eigenvector and LLSM will give the same result after normalization. The question of the most appropriate scaling method arises when the matrices of pairwise comparisons are not consistent (see [8] and [9]). Both the eigenvector method and LLSM are accepted theoretically and used often in practice with little difference in the results [5]. With pairwise comparisons completed and criteria weights

calculated, we now look at methods for ensuring the preferences of the user are consistent enough to provide reliable criteria weights.

### Consistency

Deviations from both ordinal and cardinal consistency are considered, and to a certain extent allowed, within AHP. Ordinal consistency requires that if  $x$  is greater than  $y$  and  $y$  is greater than  $z$ , then  $x$  should be greater than  $z$ . Cardinal consistency is a stronger requirement stipulating that if  $x$  is 2 times more important than  $y$  and  $y$  is 3 times more important than  $z$ , then  $x$  must be 6 times more important than  $z$ . If  $A$  is cardinally consistent, then  $a_{ij}a_{jk} = a_{ik}$ . Using the previous definition of  $a_{ij}$  we can see that this is true:

$$a_{ij}a_{jk} = \frac{w_i}{w_j} \frac{w_j}{w_k} = \frac{w_i}{w_k} \quad (12)$$

If the relationship  $a_{ij}a_{jk} = a_{ik}$  does not hold then  $A$  is said to be cardinally inconsistent. AHP has been designed to deal with inconsistent matrices (both cardinal and ordinal inconsistency), thus the problem becomes:

$$\frac{w_i}{w_j} \varepsilon_{ij} \cdot \frac{w_j}{w_k} \varepsilon_{jk} = \frac{w_i}{w_k} \varepsilon_{ik} \quad (13)$$

where  $\varepsilon_{ij} > 0$  and represents some perturbation causing  $A$  to be inconsistent, producing an  $A$  matrix that looks like the following:

$$A = \begin{bmatrix} 1 & \varepsilon_{12}a_{12} & \varepsilon_{13}a_{13} & \cdots & \varepsilon_{1n}a_{1n} \\ 1/\varepsilon_{12}a_{12} & 1 & \varepsilon_{23}a_{23} & \cdots & \varepsilon_{2n}a_{2n} \\ 1/\varepsilon_{13}a_{13} & 1/\varepsilon_{23}a_{23} & 1 & \cdots & \varepsilon_{3n}a_{3n} \\ \vdots & \vdots & \vdots & \ddots & \vdots \\ 1/\varepsilon_{1n}a_{1n} & 1/\varepsilon_{2n}a_{2n} & 1/\varepsilon_{3n}a_{3n} & \vdots & 1 \end{bmatrix} \quad (14)$$

Various methods have been devised to deal with inconsistency. Saaty [29] suggests using the following consistency index (CI):

$$CI = \frac{\lambda_{\max} - n}{n - 1} \quad (15)$$

where  $\lambda_{\max}$  is the largest eigenvalue of  $A$  and  $n$  is the number of elements within a branch being compared. If  $A$  is perfectly consistent (cardinally) then  $\lambda_{\max}$  will be at a minimum and equal to  $n$ , producing a CI equal to zero. As inconsistency increases,  $\lambda_{\max}$  increases, producing a larger value of CI. This consistency index can also be expressed as a consistency ratio:

$$CR = \frac{CI}{CI_R} \quad (16)$$

where  $CI_R$  is the consistency index for a random square matrix of the same size. Saaty suggests that CR should be less than or equal to 0.1 [30], but the choice is arbitrary. If after completion of a pairwise comparison matrix CR exceeds this threshold value then the user is instructed to go back and revise comparisons until the value of CR is acceptable.

Several methods for revising matrices to achieve an acceptable CR have been developed. The simplest method for identifying pairwise comparisons that are the most inconsistent is to compare the response from the pairwise comparison process ( $a_{ij}$ ) with a ratio derived from the calculated weights ( $w_i/w_j$ ). Those values of  $a_{ij}$  that are the most different from  $w_i/w_j$  are the pairwise comparisons that, if changed in the direction of  $w_i/w_j$ , will most improve consistency.

Karapetrovic and Rosenbloom [16] have argued this approach measures the randomness of the user's preferences and that randomness of preferences is an inappropriate measure to use. The authors argue there are legitimate reasons for inconsistency and argue that instead the test should be to make sure no mistakes were made by the decision maker in entering pairwise comparisons into the matrix. Mistakes can be detected using tools borrowed from statistical quality control when more than one pairwise comparison matrix is computed for a given problem. Karapetrovic and Rosenbloom's method involves tracking CI over time using moving average and range control charts. This method is only valid when a sufficient number of pairwise comparison matrices are completed to allow the observation of a trend over time and assumes that a given decision maker is equally inconsistent throughout a given problem.

### Step 3: Scaling Attributes

After pairwise comparisons have been made and priority weights calculated for each element within the hierarchy, the input data for each alternative must be transformed to a usable value before alternatives can be compared. A major strength of AHP is its ability to incorporate attributes that are measured on a number of different scales, at different intensities, and can include both numeric, descriptive, and categorical data.

AHP allows for a high degree of flexibility in the treatment of input data. This is achieved by converting all values to relative data. Relative values can be created by

either comparing attribute values to other alternatives being compared or by comparing attributes to an "ideal" alternative. The choice of treatments will be dependent on the type of problem and available data.

When Saaty [29] conceived AHP he carried pairwise comparisons through to the alternatives, termed relative scaling. Relative scaling has generated a large amount of criticism (see [2], [3], and [22]) and will generally not be appropriate for the road investment problem or any other problem where more than a small number of alternatives are considered. One of the criticisms of AHP is that when relative scaling is used, the addition of a new or duplicate alternative can cause the rankings of alternatives to change [3]. This is known as rank reversal.

An alternative method proposed by Saaty for dealing with alternatives is the absolute, or ideal, mode of AHP. In the absolute mode, for a given attribute, each alternative is compared with an "ideal" alternative to determine its weight, termed "scoring." The score for each attribute of each alternative will range between zero and one. A common scoring technique involves dividing each attribute value by the maximum value for that attribute present among the alternatives. This assumes the decision maker's preference for that attribute is linear. Non-linear preferences can also be accommodated within AHP by specifying a function equating various levels of an attribute value to a relative score between zero and one (Figure 3). These functions may be the result of scientific study, expert judgment, or pairwise comparisons between categorical variables.

We have now moved through the construction of the problem as a hierarchy, presented a technique of pairwise comparisons to estimate user preferences, and have discussed method to convert attribute data into a relative form. What remains is the synthesis of the information generated in the first three steps to develop a ranked list of alternatives.

### Step 4: Synthesizing Priorities

Once relative values have been calculated for each attribute of each alternative, these attribute scores are combined with the attribute weights from pairwise comparisons to determine the overall ranking of each alternative. This is accomplished using a simple additive function. The products of each attribute score and its associated attribute weight are summed across each branch of the hierarchy. This sum becomes the attribute value for the node directly above and the process is repeated at the next level of the hierarchy.

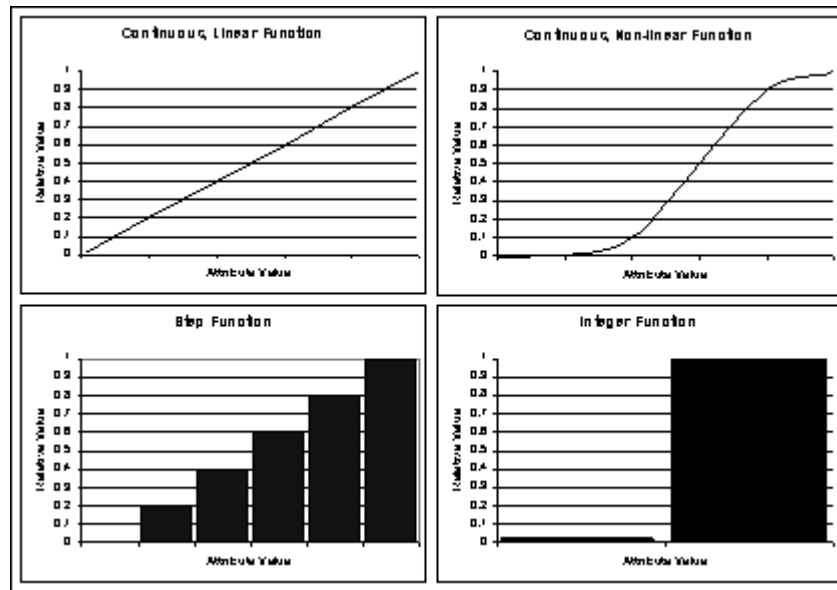

Figure 3. Four examples of functions that can be used to convert attribute values to relative scores.

Take, for example, a single objective with three sub-objectives. Using the pairwise comparison technique discussed previously, assume the weight for each of the three sub-objectives was determined to be equal to  $x_1$ ,  $x_2$ , and  $x_3$ , respectively. Every alternative under consideration will have attributes that correspond to each of these three sub-objectives. Using techniques presented in the previous section, assume each attribute of each alternative has been reduced to a relative value. We will call this relative value for a general alternative  $y_1$ ,  $y_2$ , and  $y_3$ , respectively. To calculate the overall score for the objective,  $S$ , the products of each attribute score and its associated attribute weight are summed, yielding the equation  $S = x_1y_1 + x_2y_2 + x_3y_3$ . If this objective is used as a sub-objective in the next higher level of the hierarchy, the relative value used for this attribute is  $S$ .

The overall score for a given alternative means nothing when standing alone. Only when compared with the overall scores for other alternatives does this number become meaningful. At this point, alternatives can be ranked by their importance in contributing to the goal of the analysis by simply sorting alternatives based on their overall score. Those alternatives with the higher score will receive a higher overall ranking.

## MODEL VALIDATION

Because AHP is based on the preferences of the decision maker, validation of the resulting weighting of alternatives is not possible or practical with traditional means. Kangas [14] points out that it “may be easier for the decision-maker to understand and accept this if he or she can

be made aware of the fact that his or her preferences actually determine the outcome of the decision analysis” (p. 285).

The comparison of results from an application of AHP with historic results is not appropriate because it is assumed that past results are not based on consistently applied expert judgment, otherwise there would be no reason to implement AHP. Attempts have been made to compare the results from AHP with actual preferences. Cheung et al. [4] used a line of questioning that provided additional information about the criteria decision makers were using to make their decisions. This information could then be used to refine the analysis.

In many cases the professional judgment required to structure the problem as a hierarchy and inform the model of preferences is the same professional judgment that determines if AHP is producing adequate results. The lack of a solid means of validating AHP results is one of the concerns that keeps many decision makers from utilizing the power of AHP. However, AHP is by nature designed to be used in situations where science has not yet been able to define quantifiable relationships and decisions rely, in large part, on professional judgment. As stated above by Kangas, a model built around human preferences should not be expected to produce a clear right or wrong answer.

## USES OF THE AHP IN THE PRIORITIZATION OF FOREST ROAD INVESTMENTS

The traditional use of AHP is to rank a finite, generally small, number of alternatives. This has primarily been the



focus of previous uses of AHP within natural resources. Several applications of AHP involve choosing between a small set of potential forest plans or projects (see [15], [18], [26], and [34] for examples). While this remains a useful application, the forest road investment prioritization problem differs from the traditional AHP problem in that the number of alternatives to choose from may extend into the hundreds or even thousands. Additional constraints such as budget and time also need to be included in the scheduling of forest road investments. We illustrate our approach in a small example derived from data from the Oregon State University College Forests in Western Oregon.

We assume a goal of minimizing the environmental impacts of forest roads. We limit the impacts considered in this example to road-related sediment, road-related landslides, and direct impacts to aquatic habitat for brevity. For this problem, an incomplete hierarchy structure has been constructed (Figure 4). The problem has been decomposed into three levels including the overall goal and three objectives (minimize road-related sediment entering streams; minimize road-related landslides; and minimize direct impacts to aquatic habitat), each with from two to six sub-objectives. Twelve sub-objectives form the base of the hierarchy. Table 1 describes the data given for each alternative and gives a definition for each of the twelve sub-objectives. Associated with this hierarchy are 20 potential road investments (alternatives) with attributes that correspond to the twelve sub-objectives at the lowest level of the hierarchy (Table 2). While a large number of potential road investments exist on the College Forests, 20 representative alternatives were chosen to illustrate the use of AHP in prioritizing forest road investments.

In order to use the data presented in Table 2, all attributes need to be converted to relative values between zero and one. For attributes such as sediment volume, this is done by dividing the tons of sediment produced by each road segment by the maximum sediment volume produced by any of the alternatives under consideration. For this example, the alternative with the maximum volume of sediment produced is alternative 10 with 38,343 tons of sediment. Therefore, all sediment attribute values for all alternatives are divided by 38,343 tons to reach a relative value between zero and one. The final column of Table 1 describes the conversion rule used for each attribute. Table 3 presents the relative values used for each of the 20 alternatives.

To compare the elements within the second level of the hierarchy, a decision maker would be asked three questions:

- How important is minimizing direct impacts to aquatic habitat as compared to minimizing road-related sediment entering streams in minimizing the environmental impacts of a forest road?
- How important is minimizing direct impacts to aquatic habitat as compared to minimizing road-related landslides in minimizing the environmental impacts of a forest road?
- How important is minimizing road-related sediment entering streams as compared to minimizing road-related landslides in minimizing the environmental impacts of a forest road?

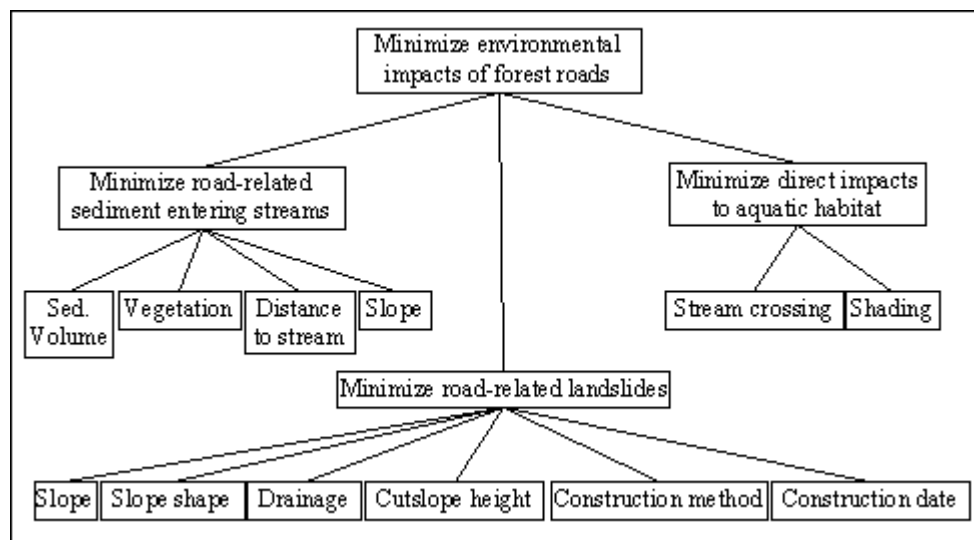

Figure 4. Hierarchy for the example problem containing an overall goal of minimizing the environmental impacts of forest roads, three objectives, and twelve sub-objectives

Table 1. Variable descriptions and the method used to convert attribute values (Table 2) to relative values (Table 3) for the example problem.

Sub-Objective	Abbreviation	Description	Conversion of Attribute Values to Relative Values
Sed Volume	Vol	Tons of sediment produced by given road segment	$\frac{Vol}{\max(Vol)}$
Vegetation	Veg	Description of vegetative cover between the road segment and the stream	None = 1 Grass = 0.5 Forested = 0
Distance to stream	Dist	Distance in feet from the road segment to a stream	$1 - \frac{Dist}{\max(Dist)}$
Slope (road-related sediment entering streams)	S1	Slope in percent between the road and the stream	$\frac{S1}{\max(S1)}$
Slope (road-related landslides)	S2	Slope in percent of the natural hillslope (excluding the road prism)	$\frac{S2}{\max(S2)}$
Slope shape	Shape	Categorical description of the shape of the natural hillslope (excluding the road prism)	Concave = 1 Planar = 0.7 Convex = 0
Drainage	Drain	Qualitative categorical description of the road drainage, ranging from poor to good	Poor = 1 Average = 0.3 Good = 0
Cutslope height	CSH	Average height of the cutslope in feet	$\frac{CSH}{\max(CSH)}$
Construction method	Method	Description of the construction method used, expressed as the percentage of the road prism constructed of sidecast material	$\frac{Method}{\max(Method)}$
Construction date	Date	Date of initial road construction	1 = pre-1950 0 = post-1950
Stream crossing	Xing	Description of fish passage through a stream crossing structure, N/A indicates the road segment does not include a stream crossing	1 = yes 0 = no or N/A
Shading	Shade	Percent reduction in stream shading due to the presence of the road segment	$\frac{Shade}{\max(Shade)}$

Table 2. Data for the 20 alternatives compared in the example problem.

Alternative	Vol	Veg	Dist	S1	S2	Shape	Drain	CSH	Method	Date	Xing	Shade
1	202	Grass	62	20	10	Planar	Good	1	0	1939	N/A	10
2	36	Grass	20	20	10	Convex	Good	1	0	1939	N/A	50
3	455	Grass	53	0	5	Planar	Good	0	0	1939	N/A	25
4	3837	Grass	105	45	5	Planar	Good	3	50	1939	N/A	25
5	4165	Grass	80	50	20	Concave	Good	8	30	1939	N/A	10
6	9570	Grass	193	45	10	Convex	Average	3	20	1939	N/A	5
7	0	Grass	246	0	5	Planar	Average	0	45	1939	N/A	5
8	255	Grass	182	45	5	Convex	Average	2	15	1939	N/A	0
9	0	Grass	201	60	30	Concave	Poor	7	35	1939	N/A	0
10	38343	Grass	0	70	30	Planar	Poor	2	50	1939	No	45
11	0167	Grass	157	45	25	Concave	Average	4	60	1939	N/A	5
12	827	Grass	121	50	15	Planar	Average	3	35	1939	N/A	40
13	207	Grass	174	45	15	Planar	Average	3	25	1939	N/A	40
14	355	Grass	0	45	2	Planar	Average	0	0	1963	Yes	100
15	3637	Grass	111	45	5	Planar	Average	0	10	1963	N/A	0
16	0	Grass	0	45	15	Planar	Average	3	10	1963	No	0
17	0	Grass	252	45	30	Planar	Average	3	15	1963	N/A	0
18	0	Grass	226	45	35	Planar	Average	2	15	1963	N/A	0
19	321	Grass	215	45	35	Planar	Poor	3	20	1963	N/A	0
20	11	Grass	81	45	15	Planar	Average	3	20	1963	N/A	0

Table 3. Relative data used in example problem using the absolute method of scoring.

Alternative	Vol	Veg	Dist	S1	S2	Shape	Drainage	CSH	Method	Date	Xing	Shade
1	0.005	0.5	0.754	0.286	0.286	0.7	0	0.125	0.000	1	0	0.10
2	0.001	0.5	0.921	0.286	0.286	0	0	0.125	0.000	1	0	0.50
3	0.012	0.5	0.790	0.000	0.143	0.7	0	0.000	0.000	1	0	0.25
4	0.100	0.5	0.583	0.643	0.143	0.7	0	0.375	0.833	1	0	0.25
5	0.109	0.5	0.683	0.714	0.571	1	0	1.000	0.500	1	0	0.10
6	0.250	0.5	0.234	0.643	0.286	0	0.3	0.375	0.333	1	0	0.50
7	0.000	0.5	0.024	0.000	0.143	0.7	0.3	0.000	0.750	1	0	0.50
8	0.007	0.5	0.278	0.643	0.143	0	0.3	0.250	0.250	1	0	0.00
9	0.000	0.5	0.202	0.857	0.857	1	1	0.875	0.583	1	0	0.00
10	1.000	0.5	1.000	1.000	0.857	0.7	1	0.250	0.833	1	0	0.45
11	0.028	0.5	0.377	0.643	0.714	1	0.3	0.500	1.000	1	0	0.05
12	0.022	0.5	0.520	0.714	0.429	0.7	0.3	0.375	0.583	1	0	0.40
13	0.005	0.5	0.310	0.643	0.429	0.7	0.3	0.000	0.000	0	1	0.40
14	0.009	0.5	1.000	0.643	0.057	0.7	0.3	0.000	0.000	0	1	1.00
15	0.095	0.5	0.560	0.643	0.143	0.7	0.3	0.000	0.167	0	0	0.00
16	0.000	0.5	1.000	0.643	0.429	0.7	0.3	0.375	0.167	0	0	0.00
17	0.000	0.5	0.000	0.643	0.857	0.7	0.3	0.375	0.250	0	0	0.00
18	0.000	0.5	0.103	0.643	1.000	0.7	0.3	0.250	0.250	0	0	0.00
19	0.008	0.5	0.147	0.643	1.000	0.7	1	0.375	0.333	0	0	0.00
20	0.000	0.5	0.679	0.643	0.429	0.7	0.3	0.375	0.333	0	0	0.00

If the response to the first question is “moderate importance”, to the second “very strong importance” and to the third “strong importance,” the A matrix would be structured as shown in Table 4.

integers from one to nine (Table 5). The integer value is given to the more preferred attribute with the reciprocal of the integer recorded for the lesser preferred attribute. For the preferences stated above (Table 4), the resulting A

Table 4. Pairwise comparison of second level of example hierarchy using verbal responses corresponding to Saaty’s linear 1-to-9 scale.

	Direct impacts to aquatic habitat	Road-related sediment entering streams	Road-related landslides
Direct impacts to aquatic habitat	1	Moderate importance	Very strong importance
Road-related sediment entering streams		1	Strong importance
Road-related landslides			1

The A matrix is completed by converting each verbal response into a numerical value. One desirable quality of a chosen scale is that the decision maker should be able to keep all possible scale values in mind at one time. Returning to the findings of Miller [21], the average individual has the capacity to keep only seven, plus or minus two, objects in mind at any one time without becoming confused. Saaty proposes a linear scale consisting of the

matrix is shown in Table 6. The second row represents “road-related sediment entering streams” as compared to “direct impacts to aquatic habitat” in the first column. Here, “direct impacts to aquatic habitat” was given moderate importance over “road-related sediment entering streams”, a value of 3 using Saaty’s original 1-to-9 scale, so the inverse value, 1/3 is entered in the first column of the second row. The second column of the second row

Table 5. The scale used in the AHP to convert verbal responses to numeric values based on the integers between one and nine (adapted from [30]).

Intensity of Importance	Definition	Explanation
1	Equal importance	Two activities contribute equally to the objective
2	Weak	
3	Moderate importance	Experience and judgment strongly favor one activity over another
4	Moderate plus	
5	Strong importance	Experience and judgment strongly favor one activity over another
6	Strong plus	
7	Very strong or demonstrated importance	An activity is favored very strongly over another, its dominance demonstrated in practice
8	Very, very strong	
9	Extreme importance	The evidence favoring one activity over another is of the highest possible order of affirmation
Reciprocals of above non-zero numbers	If activity A has one of the above non-zero numbers assigned to it when compared with activity B, then B has the reciprocal value when compared with A.	

Table 6. Pairwise comparison of second level of example hierarchy using Saaty's linear 1-to-9 scale to convert the verbal responses given in Table 4 to numeric values.

	Direct impacts to aquatic habitat	Road-related sediment entering streams	Road-related landslides	Eigenvector Weight	LLSM Weight
Direct impacts to aquatic habitat	1	3	9	0.649	0.649
Road-related sediment entering streams	1/3	1	5	0.279	0.279
Road-related landslides	1/9	1/5	1	0.072	0.072

compares “road-related sediment entering streams” to itself so a value of 1 is entered. For the third column of the second row the result of “road-related sediment entering streams” compared to “road-related landslides” is recorded with a value of 5, representing the decision maker's view that “road-related sediment entering streams” has strong importance over “road-related landslides” when minimizing the environmental impacts of forest roads.

Other methods and scales have been developed to convert verbal responses to numeric values. Lootsma [19, 20] introduced a geometric progression of values of the form  $a_{ij} = e^{s\delta_{ij}}$ , where  $s > 0$  is a scale parameter and  $\delta_{ij}$  are integers between -8 and 8, corresponding to Saaty's verbal scale. Lootsma's geometric progression was designed to be used with the LLSM. The value of  $s$  can be calibrated to match scale values to the decision maker's preferences and is an additional parameter that must be set by the user. This additional variable  $s$  adds to the uncertainty in the results, increases the complexity, and adds little to no improvement in the results. While Lootsma's geometric scale is used, the most common scale is Saaty's linear 1-to-9 scale (Table 4).

Using the matrix of pairwise comparisons, weights for each of the three objectives can be calculated using either the eigenvector or LLSM procedure (Table 6). Both methods result in a weight of 0.649 for the objective “Minimize direct impacts to aquatic habitat,” 0.279 for “Minimize road-related sediment entering streams,” and 0.072 for “Minimize road-related landslides.” Before continuing, the consistency of judgments is checked using the Consistency Ratio approach presented previously. For this set of comparisons,  $\lambda_{\max}$  is equal to 3.065, producing a CI of 0.032.

The RI for a three by three square matrix is 0.52 [30], leading to a CR of 0.062. If this CR value had been greater than a set threshold value, Saaty recommends pairwise comparisons be revised until the value of CR is acceptable. This same procedure is completed for the other three sets of pairwise comparisons needed to complete this example problem. The results of these comparisons are presented in Tables 7, 8 and 9.

In this example, the attribute value for “Minimize direct impacts to aquatic habitat” for each alternative is the sum of the relative value for “stream crossing” multiplied by the attribute weight for “stream crossing” and the relative value multiplied by the attribute weight for “shading.” This same operation is carried out for the other two branches of the hierarchy. The overall score for “Minimize environmental impacts of forest roads” then becomes the sum of each objective's value multiplied by its weight. This is shown graphically for the first alternative in Figure 5 where each attribute score is presented in italics and each element weight is presented in bold type.

When this synthesis of relative attribute values and attribute weights is completed for all 20 alternatives, the overall score for each alternative can be compared to the overall scores for the other alternatives and a ranking derived (Table 10). This ranking gives the user not only the ordinal rank of each alternative but a quantitative measure of the relative importance of each alternative. Note that the LLSM and eigenvector method produce nearly identical rankings for this example, with only the twelfth and thirteenth-ranked alternatives differing between the two methods.



Table 7. Pairwise comparisons for sub-objectives of “Minimize sediment input to streams” objective (CR = 0.074).

	Distance to stream	Sed. volume	Slope	Vegetation	Eigenvector Weight	LLSM Weight
Distance to stream	1	Moderate importance	Moderate importance	Strong importance	0.505	0.500
Sed. volume		1	Moderate importance	Strong importance	0.288	0.288
Slope			1	Moderate importance	0.143	0.147
Vegetation				1	0.064	0.066

Table 8. Pairwise comparisons for sub-objectives of “Minimize road-related landslides” objective (CR = 0.072).

	Slope	Slope shape	Drainage	Construction method	Construction date	Cut-slope height	Eigenvector Weight	LLSM Weight
Slope	1	Strong importance	Strong importance	Strong importance	Absolute importance	Very strong importance	0.484	0.424
Slope		1	Moderate importance	Strong importance	Very strong importance	Very strong importance	0.233	0.240
Drainage			1	Strong importance	Strong importance	Very strong importance	0.153	0.167
Construction Method				1	Moderate importance	Moderate importance	0.065	0.081
Construction Date					1	Moderate importance	0.038	0.052
Cut-slope Height						1	0.028	0.037

Table 9. Pairwise comparison for the objective of “Minimize direct impacts to fish” objective (CR = 0.000).

	Stream crossing	Shading	Eigenvector Weight	LLSM Weight
Stream crossing	1	Moderate importance	0.750	0.750
Shading		1	0.250	0.250

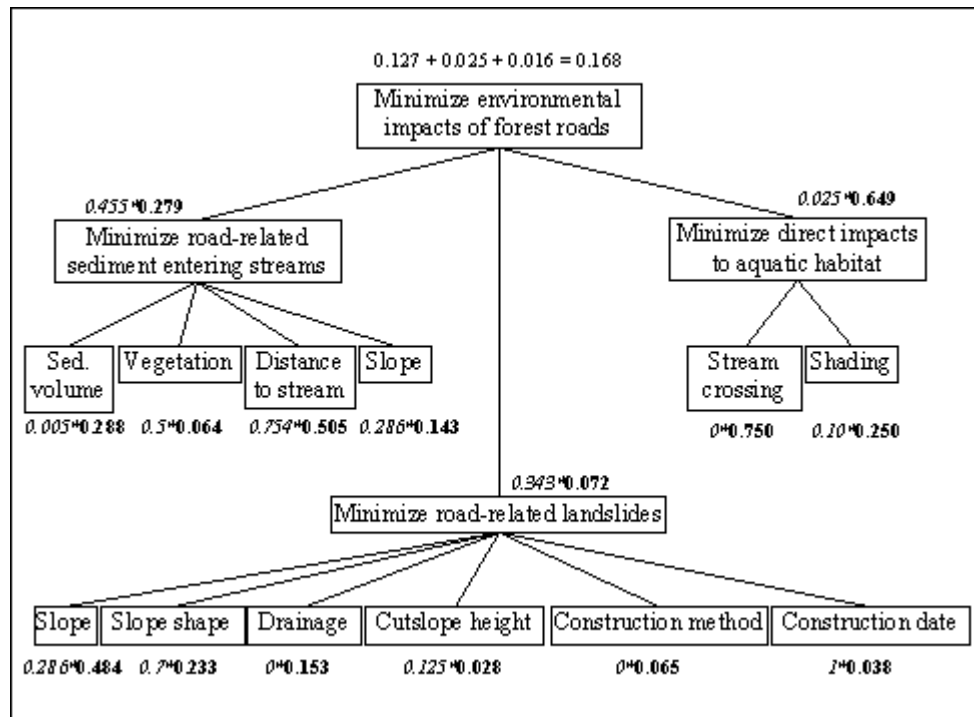

Figure 5. Calculation of overall score value for Alternative 1 of the example problem. Bold values indicate attribute weights (using the Power Method to calculate the principal right eigenvector), values in italics are relative attribute scores for Alternative 1 (Table 9).

Table 8. Overall score and ranking for the 20 alternatives in the example problem using both the LLSM and Eigenvector method of calculating weights from pairwise comparison data.

Alternative	EM Score	EM Rank	LLSM Score	LLSM Rank
1	0.168	10	0.168	10
2	0.244	3	0.243	3
3	0.181	8	0.181	8
4	0.189	7	0.192	7
5	0.202	6	0.203	6
6	0.114	16	0.115	15
7	0.047	20	0.049	20
8	0.087	18	0.089	18
9	0.136	14	0.137	14
10	0.403	2	0.403	2
11	0.151	12	0.152	12
12	0.214	4	0.215	4
13	0.179	9	0.180	9
14	0.842	1	0.842	1
15	1.142	13	0.142	13
16	0.207	5	0.206	5
17	0.081	19	0.080	19
18	0.101	17	0.098	17
19	0.116	15	0.114	16
20	0.163	11	0.162	11

### Benefit:Cost Ratios

The overall score value can also be used as a measure of the relative worth of a given alternative as compared with other alternatives. This naturally leads to a benefit:cost ratio use of the overall score values combined with some measure of economic cost. The numerator, benefit, is the overall score generated using AHP. The denominator of the benefit:cost ratio is an estimated cost to implement a solution to the problem represented by each alternative. This score was calculated using the eigenvector method and absolute scoring. This comparison is possible because the benefit for a given project is a relative value calculated on the same scale as all other alternatives under consideration. The alternatives with the higher benefit:cost ratios would be the more favored alternatives, indicating those alternatives that will provide a greater benefit for every dollar spent. Combining the cost of a given investment and the benefit that investment will produce, a new ranking of alternatives can be made that considers both factors (Table 11).

### Resource Allocation

The relative priorities derived using AHP can be used to allocate resources. For example, a simple three period integer programming allocation problem can be formulated

using the benefits and costs for each alternative:

$$\begin{aligned}
 & \text{Maximize } \sum_{j=1}^3 \sum_{i=1}^{20} x_{ij} b_i \\
 \text{s.t. } & \sum_{i=1}^{20} x_{ij} c_i \leq \$10,000 \quad \text{for every } j \\
 & x_{ij} = [0,1] \quad \text{for every } ij \\
 & \sum_{j=1}^3 x_{ij} \leq 1 \quad \text{for every } i
 \end{aligned} \tag{17}$$

Where  $i$  is the alternative (20 total),  $j$  is the period (3 total),  $b_i$  is the benefit derived through AHP for each alternative,  $c_i$  is the cost of implementing each alternative (investment), and  $x_{ij}$  is a binary variable indicating if alternative  $i$  will be completed in period  $j$ .

The total dollar value to fix or complete all of the twenty alternatives is \$68,950. For this example, only \$10,000 is available to spend in each of the three time periods. The expenditures in each of the three periods were \$7,450, \$10,000, and \$10,000, with a total benefit in each period of 1.318, 0.874, and 0.573, respectively (Table 12).

Table 11. Benefit: cost example where cost is the estimated cost to complete a given alternative and the benefit is the overall score calculated using the Eigenvector method.

Alternative	Overall Score (Benefit)	Cost (\$)	Benefit: Cost (1000*Overall Score/Cost)	Benefit: Cost Rank
1	0.168	750	0.2239	10
2	0.244	7,500	0.0326	17
3	0.181	7,000	0.0259	18
4	0.189	750	0.2526	6
5	0.202	4,000	0.0506	14
6	0.114	500	0.2281	9
7	0.047	3,000	0.0156	19
8	0.087	200	0.4351	3
9	0.136	1,500	0.0910	13
10	0.403	8,000	0.0504	15
11	0.151	4,500	0.0337	16
12	0.214	2,000	0.1068	12
13	0.179	26,000	0.0069	20
14	0.842	700	1.2032	1
15	1.142	350	0.4055	4
16	0.207	350	0.5915	2
17	0.081	400	0.2036	11
18	0.101	300	0.3355	5
19	0.116	500	0.2317	8
20	0.163	650	0.2501	7

Table 12. Per alternative results of a three period allocation problem solved using linear programming.

Alternative	Overall Score (Benefit)	Cost to Complete (\$)	Period Completed
1	0.397	750	1
2	0.412	7,500	-
3	0.366	7,000	-
4	0.392	750	1
5	0.507	4,000	2
6	0.280	500	1
7	0.135	3,000	-
8	0.226	200	1
9	0.422	1,500	1
10	0.872	8,000	3
11	0.421	4,500	2
12	0.413	2,000	1
13	0.331	26,000	-
14	0.548	700	1
15	0.362	350	1
16	0.530	350	1
17	0.262	400	1
18	0.314	300	1
19	0.362	500	1
20	0.428	650	1

Many large optimization models used to manage forest roads use an objective function with many coefficients that must be decided upon and changed by the user. The value of these coefficients is heavily dependent on professional judgment and generally no formal process for deriving these coefficients is used. AHP provides a structured process to develop professional judgments and user preferences into coefficients that can be used in an objective function. This objective function can then be used to measure the “quality” of a given solution compared to solutions in previous or future model runs. The “ideal” against which each alternative would be compared to in order to determine an attribute’s relative value would need to be set as a static value, not simply the maximum value present in a group of alternatives. These “ideal” attribute values would need to remain constant in order for overall alternative scores to be comparable. Once an “ideal” value is changed a new comparison between overall scores would be required. This application of AHP has been introduced by Saaty [31] and Schmoldt et al. [34] but has not been demonstrated widely in the literature and may be a promising arena for future work.

## CONCLUDING REMARKS

The Analytic Hierarchy Process has potential for managing existing road systems where science has not yet uncovered quantifiable relationships between cause and effect, meaning the synthesis of road inventory data to set investment priorities must rely in part on professional judgment. AHP provides users with a structured means of incorporating both scientific data and professional judgments into a replicable process. Additionally, the overall score for each alternative can be used as a measure of the relative worth of a given alternative (in relation to the overall goal) as compared to the other alternatives under scrutiny. This relative benefit can be used to further incorporate costs into the decision analysis either through the use of a benefit:cost ratio or as a constraint used in scheduling investments.

The flexibility provided by AHP requires users to make several decisions in the formulation and implementation of an AHP solution. In order to make informed decisions concerning the correct application of AHP to a particular situation, it is necessary for the decision maker to have a clear understanding of the consequences of these decisions. This paper has presented the theoretical background, benefits, and drawbacks of many of these choices. The forest road investment problem to minimize the environmental impacts of roads differs from the traditional applications of AHP in that the potential exists for large numbers of alternatives to be compared simultaneously. The measures of relative benefit of each alternative can then be used in subsequent models to allocate scarce resources such as budget and time.

## AUTHOR CONTACT

Elizabeth Dodson Coulter can be reached by email at -  
elizabeth.coulter@cfc.umt.edu

## REFERENCES

- [1] Aupetit, B. and C. Genest. 1993. On some useful properties of the Perron eigenvalue of a positive reciprocal matrix in the context of the analytic hierarchy process. *European Journal of Operational Research*. 70:263-268.
- [2] Belton, V. and T. Gear. 1983. On a short-coming of Saaty’s method of analytic hierarchies. *Omega*. 11:228-230.

- [3] Belton, V. and T. Gear. 1985. The legitimacy of rank reversal - A comment. *Omega* 13:143-144.
- [4] Cheung, S.-O., T.-I. Lam, M.-Y. Leung, and Y.-W. Wan. 2001. An analytical hierarchy process based procurement selection method. *Construction Management and Economics* 19:427-437.
- [5] Crawford, G. B. 1987. The geometric mean procedure for estimating the scale of a judgment matrix. *Mathematical Modeling* 9:327-334.
- [6] Crawford, G. B., and C. Williams. 1985. A note on the analysis of subjective judgment matrices. *Journal of Mathematical Psychology* 29:387-405.
- [7] Dube, K., W. F. Megahan, and M. McCalmon. 2004. "Washington Road Surface Erosion Model,". State of Washington Department of Natural Resources.
- [8] Fichtner, J. 1984. *Some thoughts about the mathematics of the analytic hierarchy process*. Institut Fur Angewandte Systemforschung und Operations Research, Hochschule der Bundeswehr Munchen 8403.
- [9] Fichtner, J. 1986. On deriving priority vectors from matrices of pairwise comparisons. *Socio-Economic Planning Sciences* 20:341-345.
- [10] Grivetz, E., and F. Shilling. 2003. Decision support for road system analysis and modification on the Tahoe National Forest. *Environmental Management* 32(2):218-233.
- [11] Hajkowicz, S.A., G.T. McDonald, and P.N. Smith. 2000. An evaluation of multiple objective decision support weighting techniques in natural resource management. *Journal of Environmental Planning and Management* 43(4):505-518.
- [12] Harker, P. T., and L. G. Vargas. 1987. The theory of ratio scale estimation: Saaty's analytic hierarchy process. *Management Science* 33:1383-1403.
- [13] Hornbeck, R. W. 1975. *Numerical Methods*. Englewood Cliffs, New Jersey: Prentice-Hall, Inc.
- [14] Kangas, J. 1993. A multi-attribute preference model for evaluating the reforestation chain alternatives of a forest stand. *Forest Ecology and Management* 59:271-288.
- [15] Kangas, J. J., J. Karsikko, L. Laasonen, and T. Pukkala. 1993. A method for estimating the suitability function of wildlife habitat for forest planning on the basis of expertise. *Silva Fennica* 27:259-268.
- [16] Karapetrovic, S. and E.S. Rosenbloom. 1999. A quality control approach to consistency paradoxes in AHP. *European Journal of Operational Research* 119:704-718.
- [17] Lahdelma, R., P. Salminen, and J. Hokkanen. 2000. Using multicriteria methods in environmental planning and management. *Environmental Management* 26(6):595-605.
- [18] Leskinen, P., and J. J. Kangas. 1998. Analyzing uncertainties of interval judgment data in multiple-criteria evaluation of forest plans. *Silva Fennica* 32:363-372.
- [19] Lootsma, F. A. 1991. "Scale sensitivity and rank preservation in a multiplicative variant of the analytic hierarchy process (summary)." *The 2nd International Symposium on The Analytic Hierarchy Process, Pittsburgh, Pennsylvania, 1991*, pp. 71-83.
- [20] Lootsma, F. A. 1993. Scale sensitivity in the multiplicative AHP and SMART. *Journal of Multi-Criteria Decision Analysis* 2:87-110.
- [21] Miller, G. A. 1956. The magical number seven plus or minus two: Some limits on our capacity for processing information. *Psychological Review* 63:81-97.
- [22] Millet, I., and T. L. Saaty. 1999. On the relativity of relative measures - accommodating both rank preservation and rank reversal in the AHP. *European Journal of Operational Research* 121:205-212.
- [23] Mesarovic, M.D. and D. Macko. 1969. Foundations for a scientific theory of hierarchical systems. In *Hierarchical Structures* Eds. L.L. Whyte, A.G. Wilson and D. Wilson. American Elsevier, New York, pp. 29-50.
- [24] Moshkovich, H.M., A.I. Mechitov, and D.L. Olsen. 2002. Ordinal judgments in multiattribute decision analysis. *European Journal of Operational Research* 137:625-641.
- [25] Reynolds, K. 1999. Netweaver for EMDS user guide (version 1.1); a knowledge base development system. General technical Report PNW-GTR-471. USDA Forest Service, Pacific Northwest Research Station, Portland, OR.



- [26] Reynolds, K., and E. H. Holsten. 1994. Relative importance of risk factors for spruce beetle outbreaks. *Canadian Journal of Forest Research* 24.
- [27] Robison, E. G., A. Mirati, and M. Allen. 1999. "Oregon Road/Stream Crossing Restoration Guide: Spring 1999,".: <http://www.nwr.noaa.gov/1salmon/salmesa/4ddocs/orfishps.htm>. Accessed 6/28/04.
- [28] Roy, B. 1991. The outranking approach and the foundations of ELECTRE methods. *Theory and Decisions*. 31:49-73.
- [29] Saaty, T. L. 1977. A scaling method for priorities in hierarchical structures. *Journal of Mathematical Psychology*. 15:234-281.
- [30] Saaty, T. L. 1980. *The Analytic Hierarchy Process: Planning, Priority Setting, Resource Allocation*. McGraw-Hill, New York. 287 p.
- [31] Saaty, T. L. 1986. Exploring optimization through hierarchies and ratio scales. *Socio-Economic Planning Sciences* 20:355-360.
- [32] Saaty, T. L., and G. Hu. 1998. Ranking by eigenvector versus other methods in the analytic hierarchy process. *Applied Mathematics Letters* 11:121-125.
- [33] Saaty, T. L., and L. G. Vargas. 1984. Comparison of eigenvalue, logarithmic least squares and least squares methods in estimating ratios. *Mathematical Modeling* 5:309-324.
- [34] Schmoldt, D. L., D. L. Peterson, and D. G. Silsbee. 1994. Developing inventory and monitoring programs based on multiple objectives. *Environmental Management* 18:707-727.
- [35] USDA Forest Service. 1999. *Roads Analysis: Informing Decisions about Managing the National Forest Transportation System*. U.S. Department of Agriculture Forest Service Misc. Report FS-643.