



Surveying on the Side: A study in the implementation of a tilted multibeam transducer in an ultra-shallow riverine environment.¹

By Michael O. Gonsalves², LTJG/NOAA;
Dean J. Battilana, LCDR/RAN

Department of Marine Science, University of Southern Mississippi, Stennis Space Center, MS 39529



Abstract

In 2008, students of the University of Southern Mississippi surveyed a portion of the Pearl River. Due to the ultra-shallow nature of the survey area, a multibeam mount was constructed that tilted the transducer 35° to the side with respect to nadir. Such an orientation had predicted gains of 60% in the center of the channel and facilitated the collection of data further inshore than otherwise possible. To compensate for excessive outer beam noise, a CUBE surface filtering regime was adopted. Crosscheck analysis showed the acquired data easily met IHO S-44 1a standards. This paper details the evaluation and results of such a non-traditional mount.



Résumé

En 2008, des étudiants de l'University of Southern Mississippi ont exécuté des levés hydrographiques dans une partie du fleuve Pearl. En raison de la nature extrêmement peu profonde de la zone hydrographiée, une structure multifaisceaux a été construite de manière à ce que le transducteur soit incliné de 35° par rapport au nadir. Cette orientation avait permis de prévoir une augmentation de 60% au centre du canal et permis la collecte de données plus proches de la côte que ce qui aurait été possible, autrement. Afin de compenser le bruit excessif du faisceau externe, un régime de filtrage de surface CUBE a été adopté. L'analyse par recoupement a montré que les données acquises étaient sans nul doute conformes à la S-44 de l'OHI. Cet article donne le détail de l'évaluation et des résultats de ce type de structure non traditionnelle.



Resumen

En el 2008, unos alumnos de la Universidad del Sur de Misisipi levantaron un sector del Río Pearl. Debido a la naturaleza de las aguas ultra-someras de la zona del levantamiento, una estructura multihaz fue construida de forma tal que el transductor se inclinaba a 35° con respecto al nadir. Una orientación similar había pronosticado aumentos del 60 % en el centro del canal y facilitó la recogida de datos más cerca de la costa, que era posible de otra forma. Para compensar el exceso de ruido del haz externo, se adoptó un régimen "CUBE" de filtrado de superficie. El análisis de verificaciones cruzadas mostró que los datos obtenidos cumplían fácilmente la norma S-44 de la OHI. Este documento detalla la evaluación y los resultados de un montaje similar no tradicional.

¹ Portions of this work were completed as part of the coursework associated with a Master's Degree program with the University of Southern Mississippi.

² Author to whom correspondence should be addressed. Electronic mail: michael.gonsalves@noaa.gov

I. Introduction

Each summer, students enrolled in the University of Southern Mississippi’s Hydrographic Science program design and execute a hydrographic survey in the shallow coastal waters of Gulf Coast Mississippi. Surveys are typically focused around the Pearl River, and the 2008 project area was the Port Bienville Industrial Park, a dredged slip and waterfront industrial park maintained by the Hancock County Port and Harbor Commission (NOAA 2008c), Figure 1.

Available to the students were an 18-foot open skiff (~30cm draft – used for singlebeam and side scan operations) and the university’s 30-foot research vessel *LeMoyne* (~1m draft – used for multibeam acquisition), Figure 2.



Figure 1: 2008 survey area, the Port Bienville Industrial Canal.



Figure 2: Acquisition platforms used during survey, an open skiff (top) and the, relatively, deeper draft *LeMoyne* (bottom).

The Imagenex Model 837 “Delta T” profiling sonar³ was chosen as the multibeam sonar for this particular survey. The Delta T (260 kHz) has a fixed 120° transducer swath angle with up to 480 beams per swath and a nominal transmit/receive beam width of 120° x 3° (Imagenex 2008).

Surveys by previous USM classes and historic data as published on NOAA (2008a) charts (Figure 3) suggested the average depths in the survey area to be on the order of 4 meters with some areas shoaler than 1 meter. One of the realities associated with surveying with a fixed angle multibeam sonar is that the swath width ensonified on the seafloor is a function of water depth; thus in ultra-shallow waters, one can expect an ultra-narrow swath. Ideally, a multi-transducer sweep system, bathymetric sidescan sonar or hydrographic lidar would be deployed in such shallow waters (Guenther 2007; Mayer 2008), but such resources were not available. It should also be added that there is a non-trivial risk to the equipment, vessels and surveyors when working in such a shallow near-shore environments.

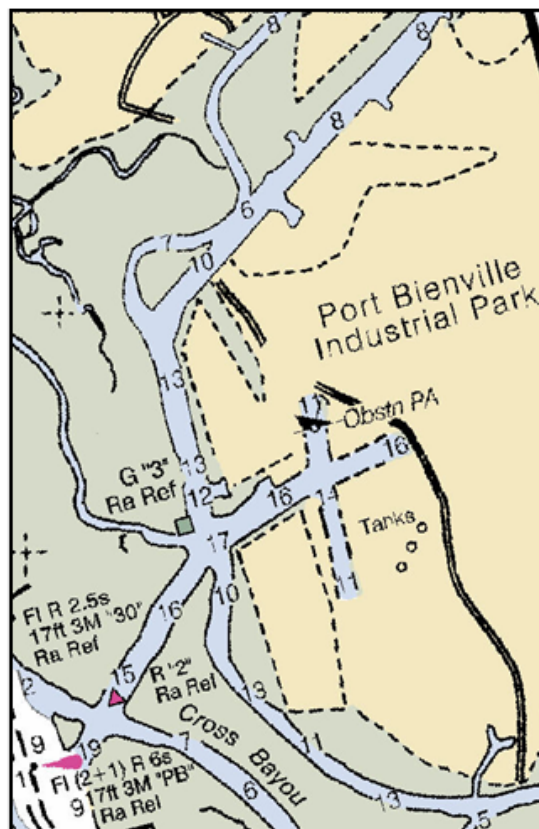

Figure 3: NOAA Chart 11367 (2008a), sounding in feet.

³ The inclusion of commercial products does not imply endorsement by USM, NOAA or RAN.

To mitigate the disadvantages (narrow swath width, proximity to shoreline) of working in such a shallow environment, a retractable bow mount was constructed for the *LeMoyne* that would tilt the multibeam transducer 35° to starboard, with respect to nadir, Figure 4. The remainder of this paper is a discussion of the thought-process and consequences of the decision to tilt the transducer head.

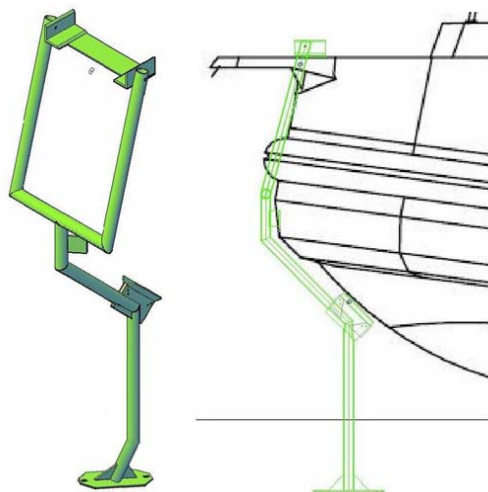

Figure 4: Multibeam bow mount constructed for *LeMoyne*

II. Advantages of a Tilted Mount

A. Increasing the swath width

There are two geometric considerations that drive the useable swath-width of a transducer: the system’s field-of-view and the horizontal beam spacing.

Consider a flat, shallow seabed. With a

traditional mounting (in this paper, “traditional” will be used in the context of an echosounder mounted with its acoustic axis oriented parallel to nadir), the transducer’s field-of-view governs the swath width, which grows linearly as a function of water depth, see Figure 5 (Zone I). In the case of the Delta T, with its 120° swath angle, the swath width is simply given by:

$$(\text{Swath Width})_{\text{TRAD}} = 2 * \text{Water Depth} * \tan(60^\circ) \quad (1)$$

In contrast is the tilted mount design. By angling the transducer 35°, the outer-most starboard beams are oriented 5° above the horizontal. Looking above the horizontal will create a theoretically infinite horizontal field-of-view (bottom topography notwithstanding), Figure 5 (Zone I). As such, the horizontal beam spacing becomes the dominant factor in determining the coverage derived from the echosounder.

This survey was designed at the most stringent standards as established by the International Hydrographic Organization and disseminated in Special Publication 44 (2008). A survey conducted to “Special Order” specifications must be capable of detecting a 1-meter cube. Following the guidance of Land Information New Zealand (2001), the center-to-center distance (i.e. bore sight spacing) should be no more than one-half the desired target dimensions: in this case, a maximum beam spacing of one-half meter was considered. Further, 200% sidescan sonar coverage was obtained throughout the survey area to satisfy target detection requirements.

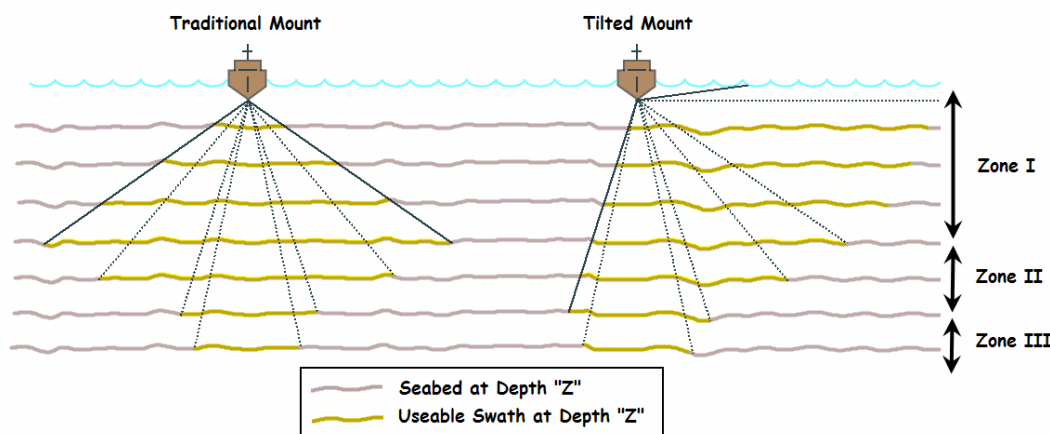

Figure 5: Comparison of swaths ensorified by a traditional and tilted multibeam mount for various depths. In Zone I the traditional mount is limited by its field-of-view, while the tilted mount is limited by horizontal beam spacing; in Zone 2 the outer beams of the traditional mount are lost due beam spacing, while only the starboard outer beams are lost in the tilted mount; in Zone 3, beam spacing has reduced both mounts to the same swath width.

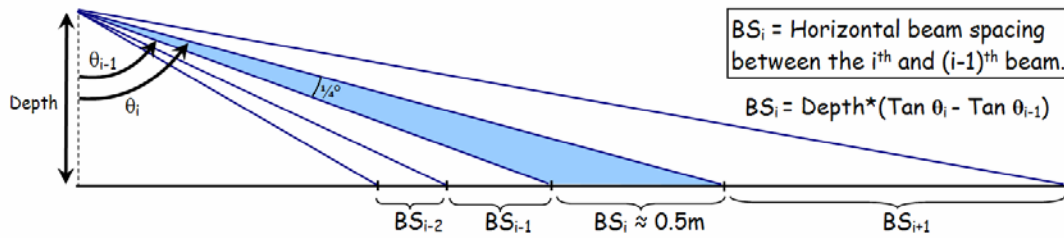

Figure 6: Swath cross-section depicting the geometry used to determine the beam angle in which the horizontal spacing of the beams' boresight becomes unacceptably large. (Note: with 480 beams distributed across 120°, the boresight of each beam is separated by 1/4° degree).

With the determination of this beam spacing, the maximum allowable beam angle off nadir can then be estimated, Figure 6:

$$(\text{Beam Spacing})_i = \text{Depth} * (\tan \theta_i - \tan \theta_{i-1}) \quad (2)$$

Note: although beams beyond this beam angle will not produce data at the desired resolution, the soundings themselves are still retained to be combined with data from overlapping tracklines.

While beam spacing must be considered at all depths with a tilted transducer, it must also be considered with a traditional mount at deeper depths. Referring back to Figure 5, Zone II represents depths in which the outermost beams of the traditionally-mounted transducer will no longer satisfy the horizontal beam spacing requirement, narrowing the effective swath width. With the tilted mount, only the starboard side of the swath will be narrowed in depths corresponding to Zone II. Depths within Zone III are sufficiently deep that the horizontal beam spacing cannot be satisfied on either side of the tilted mount's swath. Practically speaking, this implies the usable swath angle will be less than 25° to either side; hence the traditional mount and the tilted mount have the same swath width in Zone III.

Again, particular to this survey was the use of a Delta T with a 120° swath of up to 480 equiangular beams. Knowing the beam angle at which the beam spacing becomes unacceptably large, from (2), plots of useable swath width versus depth can be generated, Figure 7. Because this vessel and mount will conceivably be used by future USM students to perform their summer surveys (surveys with different parameters such as average depth or desired spot spacing), several

beam spacing options were plotted. Particular attention is called to the data point marked with the red circle in Figure 7. With an average depth of 4 meters and a desired spot spacing of 0.5 meters, there was an anticipated swath width of approximately 23 meters during the 2008 survey (which became the baseline for line spacing during survey planning). Figure 7 also shows graphically what Figure 5 shows conceptually: with increasing depth, the steady increase in the beam spacing on the seafloor will lead to an eventual decrease in the effective swath width, (see 0.1m curve).

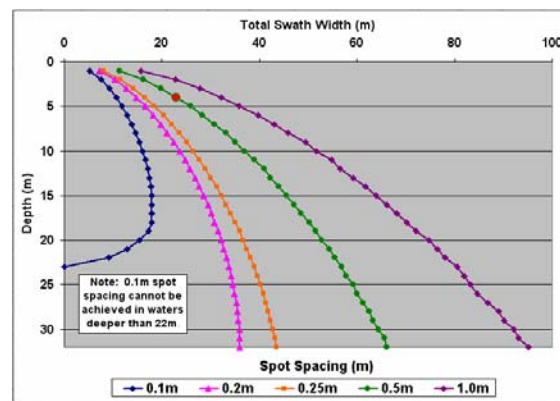

Figure 7: A comparison of effective swath width versus water depth for various maximum spot spacing (tilted transducer).

The predicted swaths of the tilted transducer can then be compared to the theoretical swaths of a traditionally mounted system to determine what gains are to be had and under what circumstances such a configuration is appropriate, Figure 8. As suggested in Figure 5, the maximum gains for a tilted transducer are experienced in extremely shallow water.

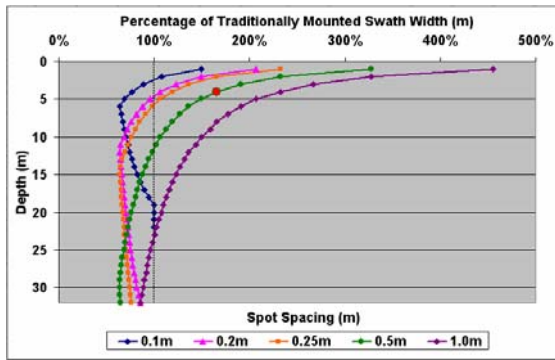

Figure 8: A comparison of the swath widths of a traditional and tilted echosounder at varying depth with various maximum spot spacing.

The anticipated survey conditions are again marked with a large red circle in Figure 8. An average depth of 4 meters leads to an anticipated swath width that is 166% that of a traditionally mounted transducer (that is an anticipated 23 meter swath compared to a 13.9 meter swath with a traditional mount). Figure 8 also shows that so long as the 2008 survey operations are confined to waters shoaler than ~11 meters, there is expected to be a net benefit to having a tilted mount. Finally, by studying the 0.1m curve, one can easily see the three zones described in Figure 5: Zone I (0 – 6m), beam spacing is limiting the outermost starboard beams (>60°) on the tilted mount; Zone II (6 – 18m), beam spacing is continuing to limit the starboard beams of the tilted mount, but is affecting both the port and starboard beams of the traditional mount (25° – 60°); Zone III (below 19m), the port and starboard outer beams are so limited that both mounts produce equivalent swaths (<25° maximum beam angle from nadir).

A portion of the 2008 survey area was also surveyed in 2005, Figure 9. The increase in data coverage with a tilted mount can easily be seen in a shallow water environment (maximum depth of 4.5 meters in the intersection of the waterways). Note the 2005 survey employed a RESON 8101 with a 150° internal swath angle (as compared to the 120° swath angle of 2008). Also note the 2008 survey acquired an additional two lines of data in each canal (typically acquired along either shoreline).

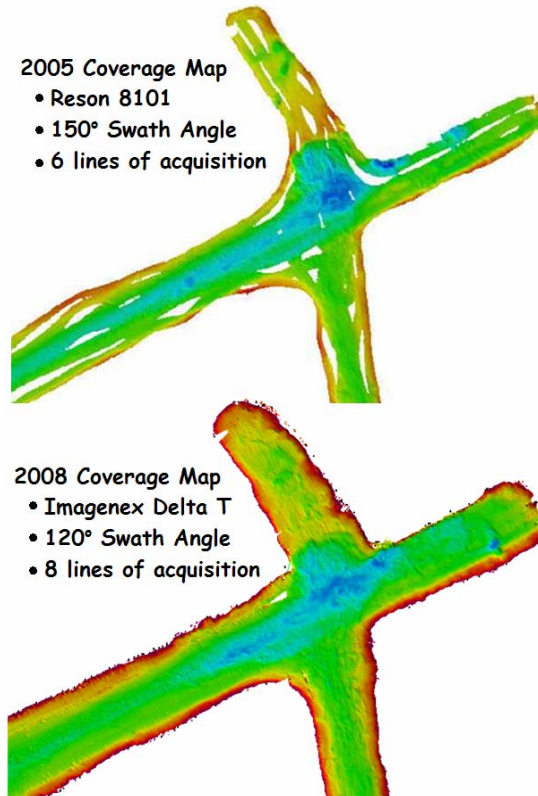

Figure 9: Comparing the coverage obtained with a traditional transducer mount (2005) to that from a tilted mount (2008): 1-meter DTMs shown

B. Acquiring data further inshore

In addition to increasing the transducer’s swath width, a tilted design also permits the acquisition of data further inshore than otherwise possible, Figure 10. A survey vessel’s draft is typically the limiting factor in defining the inshore limits of hydrography. By tilting the transducer mount, soundings can be acquired closer to the shoreline while the survey vessel can maintain a safe distance from shore and the seafloor. In a similar manner, shoal soundings can be more safely and efficiently measured on submerged features like rocks or obstructions.

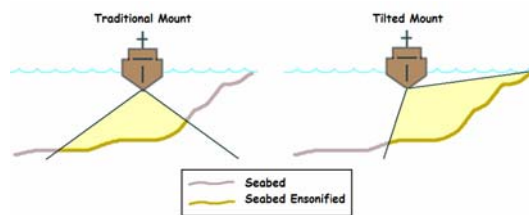

Figure 10: A tilted mount facilitates data acquisition further inshore than a traditional mount.

In an effort to acquire data right up to the land-water interface, the transducer was oriented such that the outermost beams are aimed *above* the horizontal, Figure 11. Given the transducer is mounted below the water’s surface, the survey vessel must maintain a given distance from the shoreline to permit the full ensonification of the sea floor:

$$\text{Distance to Shoreline} = (\text{Transducer Depth}) / \tan(\alpha) \quad (3)$$

With a transducer depth of 1 meter, and a swath angled 5° above the horizontal, it was computed the *LeMoyne* needed to maintain a minimum distance of 11.4 meters offshore to survey to the land-water interface (a distance well within the range of the Delta T).

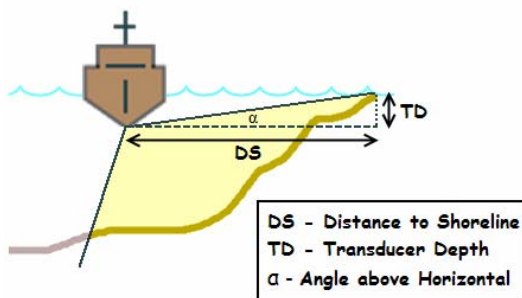

Figure 11: Geometry of look angle above horizontal as it relates to horizontal distance from shoreline.

Figure 12 shows a comparison of swaths of data as obtained from the singlebeam-equipped skiff and the multibeam-equipped *LeMoyne*. Note that despite the *LeMoyne* being 5 meters further offshore, the tilted multibeam mount still acquired data ~5 meters further inshore than the shallow draft skiff. Further, in this instance, multibeam data was acquired right up to the 0-meter contour along the shoreline.

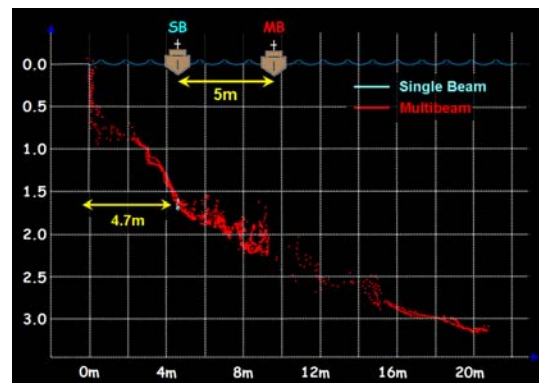

Figure 12: Comparison of bathymetric data acquired by a relatively shallow draft singlebeam vessel and the deeper draft multibeam vessel.

A complete cross-section of the survey area is shown in Figure 13. In this particular study area, the singlebeam data was acquired while being mindful to get as close to the shoreline as possible. The northern bank had a vertical pier face with some smaller catwalks extending from

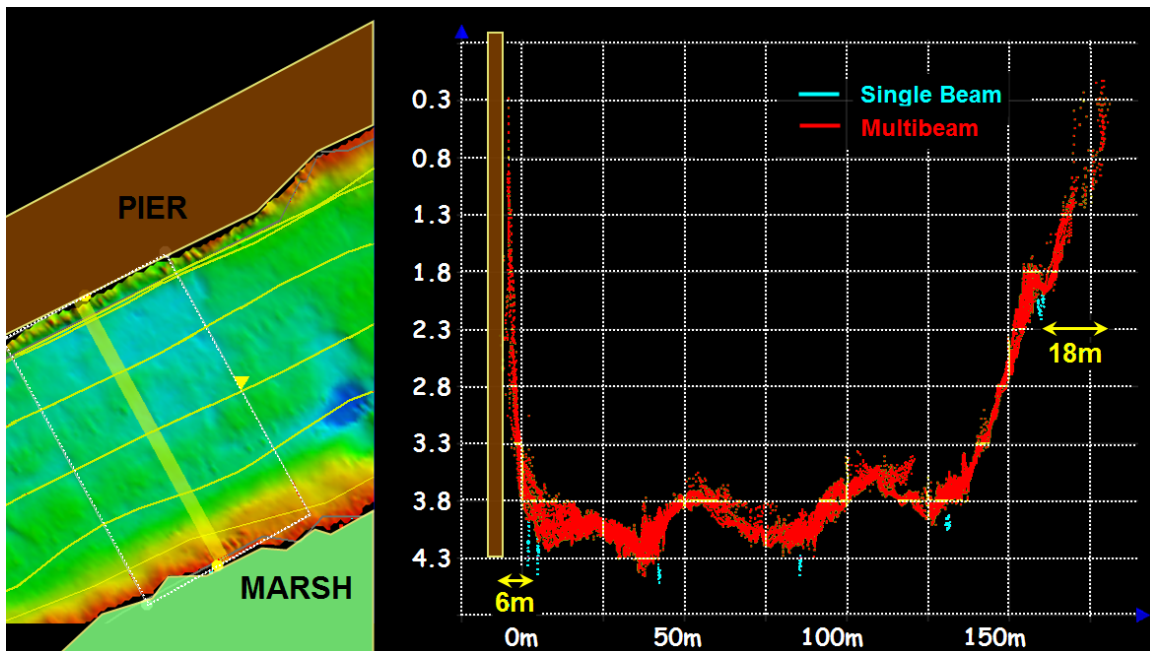

Figure 13: Canal cross section showing both singlebeam and multibeam data coverage. The northern bank was bordered by a vertical pier face, while the southern shore was a low-lying marsh; in both instances, it was attempted to acquire singlebeam data as close to the shoreline as possible – in both instances, the tilted mount acquired data further inshore.

the wall. Here, the tilted mount was able to acquire full data under the catwalks and get a reasonable profile of the pier wall itself.

The southern bank was more typical of the survey area, being a low-lying gently sloping marshy environment. Sea grass and other vegetation forced the skiff to remain offshore (indeed it forced the *LeMoyne* to remain 5 meters further offshore). In spite of these conditions, the tilted mount acquired data 18 meters further inshore than the data sets acquired from the relatively shallow-draft skiff. Note: there is a shoal bias within the multibeam data as compared to the singlebeam due to the relatively higher frequency of the Delta T (260 kHz versus 200 kHz), combined with the muddy sediments of the Pearl River.

One can also look back to Figure 9 to gain an appreciation of just how much further inshore successful data acquisition was achieved. In 2005, the landward-most depths were typically on the order of 1.5 meters; whereas the 2008 survey routinely surveyed to ~0.3 meters.

III. Other Geometric Considerations

A. Shadow Zones

With an increased dependence on outer beams, there is an increased likelihood of features being lost in the shadow zone of other features, Figure 14. Further, as the beams approach horizontal, their associated shadows grow larger. This phenomenon can cause problems for the hydrographer with feature detection requirements.

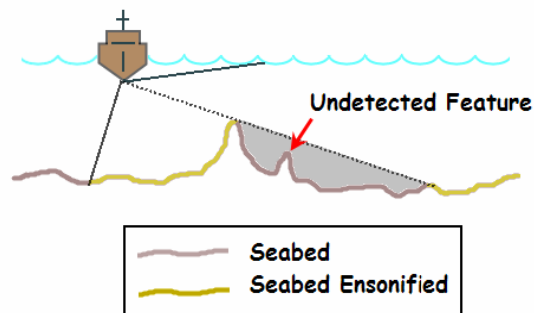

Figure 14: A demonstration of how smaller features can escape detection by lying within the shadow of larger features.

There are three reasons why these potentially undetected features were not of concern during this particular survey. First, geometry dictates the

undetected feature will be smaller in height than the detected feature, thus the more navigationally significant features are being identified. Second, by acquiring data with the tilted mount aimed towards the shoreline, any shadow zones will be shoreward of the identified features. Within the canal, this would place the shadows a few feet from the shore and were thus deemed not navigationally significant. Third, coverage maps were examined to locate any holidays of sizeable interest. Holidays in the 1-meter surfaces were considered for reacquisition.

Finally, the reader should be reminded the survey area was dominated by mud with no feature protruding an appreciable distance from the bottom. Were this a rocky area, more resources would need to be invested in these shadow zones.

B. Sonar Calibration

By mounting the transducer in a tilted fashion, an extraordinarily large roll bias is introduced into the data. This bias necessitates a modification of the conventional calibration routine (i.e. the patch test). In the context of this paper, the “conventional routine” will be the one employed by NOAA (2008b).

The residual biases to be determined include timing, pitch, roll and yaw (heading). With a traditionally-mounted transducer, the pitch bias is determined by running reciprocal lines directly over a distinct feature on the seafloor, Figure 15 (top). Unfortunately, with a tilted mount, the transducer’s central axis is no longer oriented towards nadir. Thus the aforementioned line plan will confound the pitch bias with yaw, Figure 15 (middle). To resolve this issue, lines should be offset enough that the central beam of the transducer passes directly over the desired target, Figure 15 (bottom). Such a regime will successfully decouple pitch and yaw.

In addition to resolving the pitch bias, offset reciprocal lines can also quantify any roll bias. The yaw bias is determined by capturing the target within the outer beams. This can actually be accomplished by running (non-offset) reciprocal lines. Timing is determined in the usual manner: rerunning any line at different speeds.

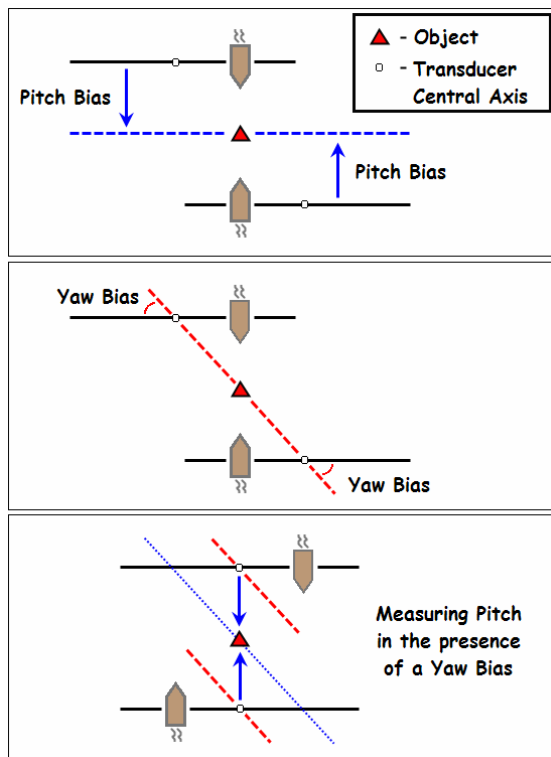

Figure 15: Overhead views of a sonar calibration routine: (top) reciprocal lines are typically used to identify a pitch bias; (middle) with a tilted mount, a yaw bias can be mistaken for pitch; (bottom) by aligning the transducer's central beam on reciprocal lines, the pitch and yaw bias can be decoupled.

Ideally, these calibration lines should be run in waters as deep as practical. The increased depths will lead to increased lever arms, where fine changes in the transducer's orientation will have a magnified effect on the calibration target's location. In turn, the calibration parameters can be determined to a high degree of accuracy.

As the title of this paper suggests, "deep" waters were not readily available for this survey. Further, the muddy canals presented no distinct features. A sonar target was constructed for the purpose of aiding in calibration, but no amount of fabrication could overcome the extremely shallow depths of the work environment. This led to (what could be considered) larger than normal estimated uncertainties in the transducer alignment.

IV. Data Processing

A. Uncertainty

Because the authors had not previously worked with a tilted transducer, the effects of the extreme

geometry on the uncertainty of the beams was unknown. Uncertainty is key in determining the IHO Order of survey achieved and in implementing the CUBE algorithm. As such, a thorough uncertainty analysis was performed. Table 1 shows the non-zero uncertainty parameters that were input into the CARIS Vessel Editor and Total Propagated Uncertainty (TPU) dialog. For context, post-processed kinematic GPS observations were used for horizontal positioning (15-km baseline) while a traditional tide gauge was used to establish the vertical datum.

Uncertainties (1-sigma)			
Device Model: Imagenex DeltaT (260kHz w/ Orientation)			
Gyro (deg)	0.02	Boat Speed (m/s)	0.03
Heave % Amp	5.0	Heave (m)	0.05
Roll (deg)	0.02	Pitch (deg)	0.02
Draft (m)	0.03	Loading (m)	0.03
Position (m)	0.05	Nav. Timing (s)	0.10
Offsets (m)	0.005	Delta Draft (m)	0.02
MRU Align Gyro	0.30	MRU Align Roll/Pitch	0.58
Tide Zoning (m)	0.05	Tide Measured (m)	0.01
SV Surface (m/s)	0.5	SV Measured (m/s)	0.1

TAB. 1. Summary of uncertainties (one standard deviation) used in CARIS TPU calculations.

Figure 16 (top) shows the propagated uncertainty profiles of three swaths acquired relatively nearshore in less than 4 meters of water. When the vertical TPU is viewed across the swath, trends similar to a traditional mounting are observed: lower uncertainties are observed closer to nadir; a symmetric uncertainty about the nadir beam; and the uncertainty grows geometrically towards the outer beams. For the nearshore swaths shown in Figure 16, IHO Special Order is achieved up to 85° off nadir and IHO Order 1 accuracies are demonstrated across the entire swath.

When considering a swath acquired in the center of the channel, the magnitudes of the uncertainties are similar to those collected nearshore; although one notable difference is an apparent plateau in the uncertainty of the starboard outermost beams of the offshore swaths, Figure 16 (bottom). The cause of this plateau can be understood by comparing the uncertainty for a given swath with the associated slant ranges of the soundings, Figure 17. For the near horizontal beams (greater than 80° from nadir) there is a near one-to-one correspondence between uncertainty and slant range; thus, at this extreme geometry, the uncertainty is driven by

the path length the pulse must travel through the water. Interestingly, these near horizontal beams have an almost constant range; therefore, their likely source is a sonar operator who had the range scale set too low, Figure 18. Lowering the range scale has an associated shortening of the pulse repetition rate, as such, the pulses from the outermost beams are not given sufficient time to propagate through the water column before the transducer fires a subsequent pulse. This is another example of the balance a hydrographer must make between enlarging swath widths and diminishing resolutions. Figure 19 shows the depth profile for the swath discussed in Figure 17. When viewing the depth profile, the outer beam noise is clearly seen.

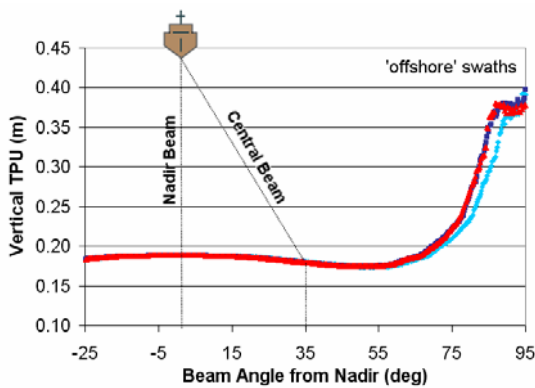
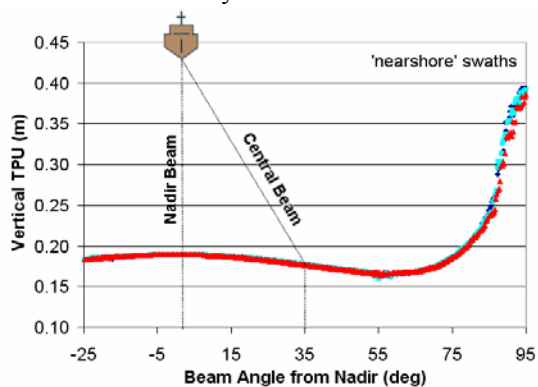

Figure 16: A beam-by-beam comparison of vertical TPU versus beam angle for three nearshore (top) and three offshore swaths (bottom); note the strange uncertainty 'plateau' in the starboard-most beams of the offshore swaths.

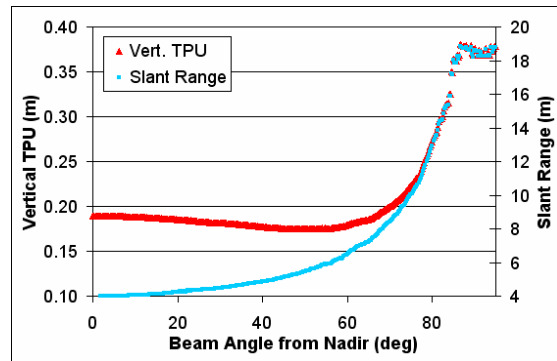

Figure 17: A comparison of vertical TPU versus slant range for one offshore swath; note the high correlation for beams beyond 80° from nadir.

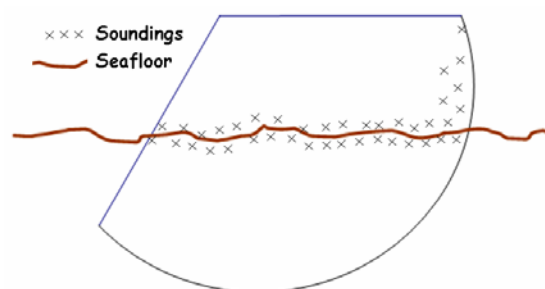

Figure 18: A visualization of the seafloor and the measured soundings as viewed through a sonar acquisition window. An improper range scale setting will lead to a truncation of outer beams due to a shortened receive time.

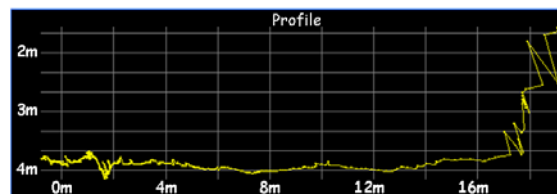

Figure 19: Depth profile for the swath displayed in Figure 17.

The outer beam noise having such a relatively large TPU is beneficial for the purposes of product creation. All surfaces were created using the CUBE algorithm, where the large sounding uncertainty would ensure a low weighting in the inclusion of surface generation. In the central channel, however, there were some sufficiently dense clusters of noisy data that caused CUBE to pull its hypotheses off the true bottom and into the water column. To clean-up some of these stray hypotheses, a data filtering paradigm was implemented that was modeled after the Royal Australian Navy, Figure 20.

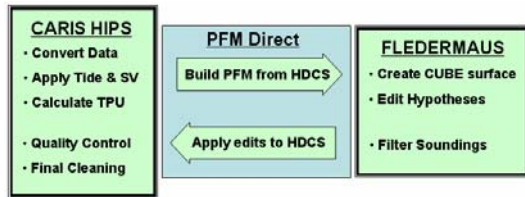

Figure 20: Data processing pipeline where HIPS was used for initial data conversion and quality control, but Fledermaus was used for the majority of the hypotheses and sounding editing.

B. Data filtering

All data files were first converted in CARIS HIPS, where tide and sound speed correctors were applied and TPU was computed. The CARIS HDCS data files were then imported into Fledermaus via PFM Direct. Within Fledermaus, the data was gridded at a 1 meter² resolution using the CUBE algorithm (density and locale disambiguation method). While CUBE was efficient in discriminating the true bottom in the majority of the survey area, the abundance of outer beam fluff in the central channel led to many ‘spikes’ in the terrain models, Figure 21. Because there were far fewer inconsistent hypotheses (Figure 22B) than inconsistent data points (Figure 22A), the data cleaning regime focused on correcting the relatively few stray hypotheses rather than the traditional ‘dot-killing’ approach.

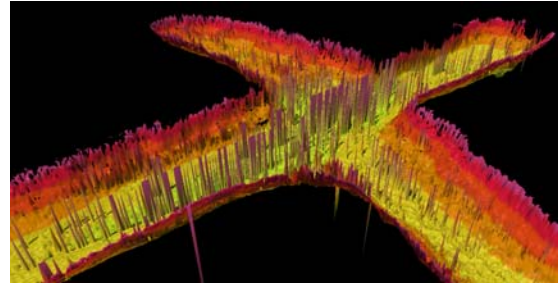

Figure 21: Initial 1m resolution surface: while the CUBE algorithm worked well in delineating the bottom near the riverbanks, there were many erroneous spikes seen in the central channel.

The CUBE hypotheses were viewed through the Fledermaus 3D Editor. For each hypotheses that appeared to be generated by errant data, alternative hypotheses were nominated (when available) closer to the ‘true’ seafloor. In the rare cases where an alternative hypotheses was not available, a custom hypotheses would be nominated from the available data. It should be noted that the entire project area was first surveyed with 200% side scan coverage. This ensured that any potential contacts were not inadvertently discarded during the hypotheses editing stage. Once the hypotheses editing was complete (Figure 22C), all soundings greater than 1.5 standard deviations from the newly edited CUBE surface were flagged as rejected (Figure 22D). Finally, the flagging was reapplied to the HDCS data files via PFM Direct.

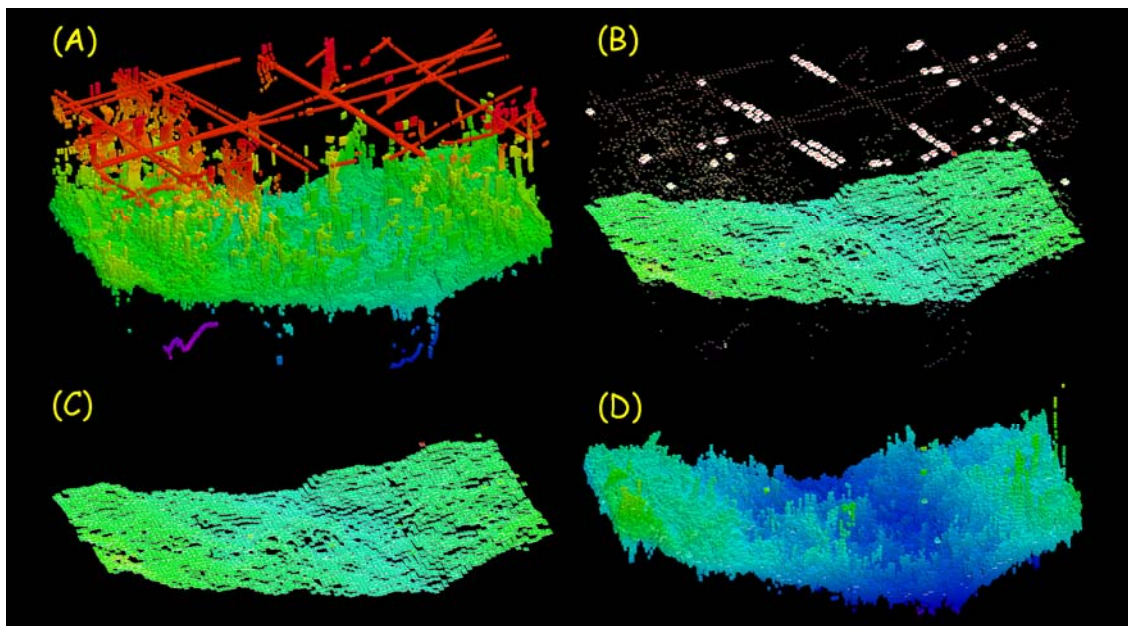

Figure 22: Acquired data under different stages of editing: A – Initial dataset; B – Initial hypotheses set with questionable hypotheses highlighted; C – Edited hypotheses; D – Finalized dataset produced by filtering soundings to within 1.5 standard deviations of the edited hypotheses.

In the case of Figure 22, over 150,000 soundings were rejected through the editing of only 80 stray hypotheses. An example of the final cleaned dataset and surfaces are shown in Figure 23.

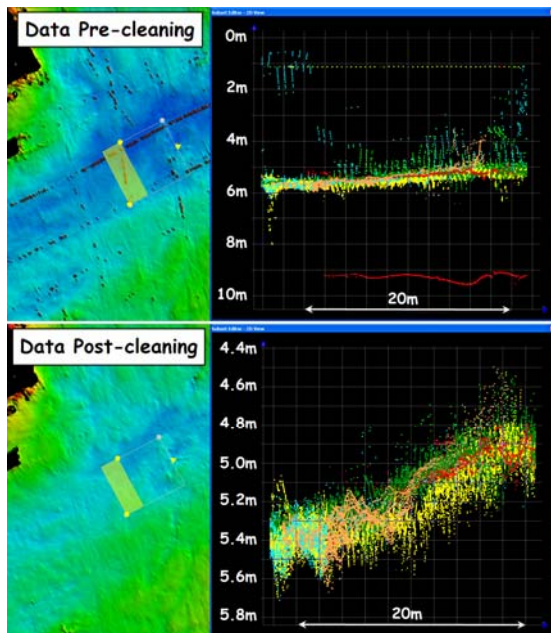

Figure 23: Results of the data filtering process: finalized CUBE surfaces were created in CARIS at 0.5m resolution (note different vertical scales are applied between plots).

V. Results

A key metric of the quality of a dataset is whether the data is internally consistent. To that end, a crossline analysis was performed, running tracklines perpendicular to the main scheme hydrography, Figure 24. Due to physical limitations, crosscheck analysis can not be performed on survey lines that were acquired along the riverbanks, thus Figure 24 is an analysis of the noisier swaths acquired in the central channel.

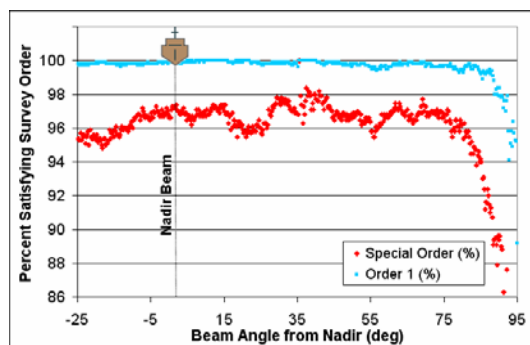

Figure 24: Final crossline analysis of cleaned dataset.

Referencing Figure 24, over 98% of the soundings acquired from beams up to 90° from nadir satisfy IHO Order 1. Additionally, over 96% of the soundings acquired from beams up to 80° from nadir satisfy IHO Special Order.

One of the principle concerns with using a tilted transducer mount configuration is whether the hydrographer will gain more data on the upslope side of the transducer than is lost on the downslope. Further, one must confirm that the data gained is, in fact, quality data and not outer beam noise. So long as the hydrographer has an understanding of the local depths and their desired sounding resolution, a successful survey can be conducted using a tilted transducer head. The tilted head offers the benefits of an increased swath width in shallow water (60% increased widths in 4 meters depth) and the ability to acquire depths closer to the shoreline and around obstructions where it may be otherwise unsafe to do so. Finally, with a proper data processing scheme (similar to one used by the Royal Australian Navy) excess noise resulting from the offshore outer beams are easily mitigated.

Acknowledgments

The authors wish to acknowledge the help and support of their classmates who shared in the collection and analysis of this data, in particular Jessica Burt, Kim Collins, Bryan Mensi and Megan Palmer. They would also like to acknowledge Dr David Dodd and Dr. David Wells of the University of Southern Mississippi for pushing them to refine their results into something worthy of dissemination.

References

Guenther, G. C. (2007). Airborne Lidar Bathymetry. In D.F. Maune (Ed.), *Digital Elevation Model Technologies and Applications: The DEM Users Manual* (2nd ed., pp 253 - 320). Maryland: American Society for Photogrammetry and Remote Sensing.

Imagenex Technology Corporation. (2008). *Delta T Imaging*. Retrieved August 22, 2008, from www.imagenex.com/html/delta_t_imaging.html.

International Hydrographic Organization. (2008). *IHO Standards for Hydrographic Surveys* (5th ed.). Special Publication No. 44. Monaco: International Hydrographic Bureau.

Land Information New Zealand (2001). "Standards for Hydrographic Surveys (HYSPEC) Version 3," *TH Standard 31*. National Topographic/Hydrographic Authority.

Mayer, L. (2008). Survey Design and Planning. *Proceedings of the 46th Multibeam Sonar Course*, San Diego, CA: Learned information.

National Oceanic and Atmospheric Administration. (2008a). *Chart 11367: Waveland to Catahoula Bay* (35th ed.). Maryland: U.S. Department of Commerce.

National Oceanic and Atmospheric Administration. (2008b). *NOS Hydrographic Surveys Specifications and Deliverables*. U.S. Department of Commerce.

National Oceanic and Atmospheric Administration. (2008c). *U.S. Coast Pilot 5* (5th ed.). Maryland: U.S. Department of Commerce.

Biographies of the authors

LTJG Michael O. Gonsalves is a NOAA Corps officer presently assigned to NOAA's Remote Sensing Division (National Geodetic Survey), stationed in Southern Mississippi.

LCDR Dean J. Battilana is an officer with the Royal Australian Navy who is presently the Instructor for the Australian Navy's Cat B program.