

Eastern Michigan University
DigitalCommons@EMU

Master's Theses and Doctoral Dissertations

Master's Theses, and Doctoral Dissertations, and
Graduate Capstone Projects

2014

Balancing design theories and individual needs in residential modifications for people living with ALS

Gail J. Weber

Follow this and additional works at: <http://commons.emich.edu/theses>

 Part of the [Interior Architecture Commons](#)

Recommended Citation

Weber, Gail J., "Balancing design theories and individual needs in residential modifications for people living with ALS" (2014).
Master's Theses and Doctoral Dissertations. 717.
<http://commons.emich.edu/theses/717>

This Open Access Thesis is brought to you for free and open access by the Master's Theses, and Doctoral Dissertations, and Graduate Capstone Projects at DigitalCommons@EMU. It has been accepted for inclusion in Master's Theses and Doctoral Dissertations by an authorized administrator of DigitalCommons@EMU. For more information, please contact lib-ir@emich.edu.

Balancing Design Theories and Individual Needs
in Residential Modifications for People Living with ALS

by

Gail J. Weber

Thesis

Submitted to the School of Engineering Technology

Eastern Michigan University

in partial fulfillment of the requirements

for the degree of

MASTER OF SCIENCE

in

Interior Design

Thesis Committee:

Shinming Shyu, Ph.D., Chair

Jiang Lu, Ph.D.

James Stein, Ph.D.

April 28, 2014

Ypsilanti, Michigan

Abstract

This research and design project examines the philosophies and psychological factors of aging in place and universal design, as well as the Americans with Disabilities Act Accessibility Guidelines (ADAAG), and how they can be realistically applied in interior design for people living with amyotrophic lateral sclerosis (ALS), a terminal illness with an approximate two- to five-year prognosis. The case study explores the design needs and preferences of one couple living with ALS. Analysis of the case study suggests that a complete universal design or ADAAG-compliant overhaul in the home is ill-advised for these subjects, given their modest budget and limited time for a person with ALS to implement and utilize extensive home modifications. The findings suggest prioritizing modifications to provide function and accessibility in key areas of the home, meeting the subjects' preference for design that doesn't look institutional, maintaining or improving the home's real estate value, and considering possible future needs of the surviving spouse as s/he ages. In the first version of the design, universal design principles and accessibility guidelines are prioritized and strategically applied to maximize autonomy, engagement, and quality of life for the subject living with ALS and the spouse in the role of caregiver. In the second version of the design, universal design principles are applied throughout the home and landscape in a project of larger scope and budget, which would be appropriate for a person who will live in the home long-term.

Keywords: aging in place, universal design, ADAAG, ADA, accessibility, ALS

Table of Contents

Abstract.....	ii
List of Figures.....	v
Chapter 1: Introduction and Background.....	1
Growth in Aging Population.....	1
Disabilities in Aging Population.....	1
Preference for Aging in Place.....	2
Costs and Longevity.....	3
Statement of the Problem.....	4
Purpose of the Study.....	4
Hypothesis.....	5
Significance of the Study.....	5
Limitations of the Study.....	5
Chapter 2: Review of Related Literature.....	6
Aging in Place.....	6
Psychological and Social Factors of Aging in the Built Environment.....	8
Accessible Design and the Americans with Disabilities Act	
Accessibility Guidelines.....	10
Universal Design.....	11
Amyotrophic Lateral Sclerosis [ALS].....	17
Chapter 3: Research Design and Methodology.....	23
Chapter 4: Results and Discussion.....	24
Interview.....	24

Home Analysis	30
Chapter 5: Conclusion and Recommendations for Further Research and Action	34
Chapter 6: Application of Findings in Design 1	36
Design Concept and Background	36
Goals	36
Solutions	36
Chapter 7: Application of Findings in Design 2	49
Design Concept and Background	49
Goals	49
Solutions	49
References	72
Appendix A Interview Questionnaire	82
Appendix B Recruitment Script	83
Appendix C Informed Consent	85

List of Figures

<u>Figure</u>	<u>Page</u>
1 Existing plan view	38
2 Remodel plan view	39
3 South exterior elevation	39
4. Existing first floor full bathroom plan view	41
5. Remodel first floor full bathroom plan view	41
6. Remodel first floor full bathroom north elevation	42
7. Remodel first floor full bathroom south elevation	42
8. Remodel kitchen south elevation	44
9. Remodel powder room east elevation	45
10. Remodel powder room north elevation	45
11. Remodel finish floor plan. This figure illustrates the finishes for the first floor in the remodeled design	47
12. Remodel furniture floor plan	48
13. First floor plan view: exterior ramp, stairs, retaining wall planters, first floor deck with enclosed wheelchair lift, and door between garage and kitchen	50
14. First floor plan view of existing south staircase and adjacent coat closet and foyer	52
15. Lower level plan view of existing south staircase and adjacent laundry room	52

16. Post-renovation first floor plan view of elevator and adjacent coat room and foyer.....	53
17. Post-renovation lower level plan view of elevator and adjacent machine room, storage room, laundry/craft room, and lower level living room.....	53
18. Post-renovation section cut of elevator and adjacent machine room, storage rooms, and coat room, and foyer.....	54
19. First floor plan view of existing north open staircase.....	55
20. Post-renovation first floor plan view of north open staircase with platform wheelchair lift installation.....	55
21. Post-renovation lower level plan view of north open staircase with platform wheelchair lift installation.....	56
22. First floor powder room plan view.....	58
23. First floor powder room south elevation.....	58
24. First floor powder room west elevation.....	59
25. Existing master bathroom plan view.....	60
26. Post-renovation master bathroom plan view.....	60
27. Post-renovation master bathroom west elevation.....	61
28. Post-renovation master bathroom north elevation.....	62
29. Post-renovation master bathroom east elevation.....	62
30. Post-renovation lower level guest bathroom plan view.....	63
31. Post-renovation lower level guest bathroom north elevation.....	64
32. Post-renovation lower level guest bathroom east elevation.....	64
33. Post-renovation kitchen plan view.....	65

34. Kitchen wall cabinet lift section cut.....	66
35. Post-renovation kitchen north elevation.....	67
36. Post-renovation kitchen south elevation.....	68
37. Post-renovation kitchen west elevation.....	68
38. Post-renovation first floor furniture floor plan.....	70
39. Post-renovation first floor finish floor plan.....	70
40. Post-renovation lower level furniture floor plan.....	71
41. Post-renovation lower level finish floor plan.....	71

Balancing Design Theories and Individual Needs
in Residential Modifications for People Living with ALS

Chapter 1: Introduction and Background

Growth in Aging Population

Baby boomers are not babies anymore, and as they get older, they are challenging the conventions of aging. “In 2011, the first of the baby boom generation reached what used to be known as retirement age. And for the next 18 years, boomers will be turning 65 at a rate of about 8,000 a day” (American Association of Retired Persons [AARP], n.d.). The term baby boomers refers to the generation of people born from mid-1946 to 1964 in the dramatic rise in birth rates after World War II (U.S. Census Bureau, 2011b, p. 4). This huge population is going gray, and as baby boomers age, they have the power of numbers to compel society to adapt to their needs. In 2011, 41.4 million people age 65 and older were living in the United States, an increase of 6.3 million (18%) since 2000 (Administration on Aging, 2012). The number of people age 65 and older in the United States is projected to continue to rise, reaching 47.7 million in 2015 (14.84% of the total population) and 92 million in 2060 (21.9% of the total population; U.S. Census Bureau, 2012). The number of people age 85 and older is also projected to rise as baby boomers reach older ages, from 5.7 million in 2011 to 14.1 million in 2040 (Administration on Aging, 2012).

Disabilities in Aging Population

The growing population of people age 85 and older is notable, because people in this group report a much higher rate of limitations in activities than that of people age 65-74 and 75-84 (Administration on Aging, 2012), possibly necessitating home modifications or a relocation to an institutional care setting. Disability is reported in people younger than age

85, too. Of people age 60 and older who are not institutionalized, 31.6% (over 18 million people) reported having some kind of disability (U.S. Census Bureau, 2011). In 2010, 28% of non-institutionalized Medicare beneficiaries age 65 and older indicated that they had difficulty in performing one or more ADL (activities of daily living including bathing, dressing, eating, and getting around the house), and an additional 12% reported difficulty with one or more IADL (instrumental activities of daily living including cooking, shopping, financial management, using the telephone, housework, and taking medication; Administration on Aging, 2012).

Preference for Aging in Place

Many people who are aging express a desire to remain living at their home rather than move to a nursing home or other institutional residence. 75% of middle aged and older adults reported a strong desire to reside as long as possible in their current homes (American Association of Retired Persons [AARP], 2010). The preference for aging in place has merit: people experience increased quality of life and independence from the stability in their environment, and staying in their own homes is often less expensive than living in a nursing home or other residential facility (Sixsmith & Sixsmith, 2008). Mattimore, Wenger, Desbiens, Teno, Hamel, Liu, et al.'s study indicates that most older adults prefer to live in their own homes for as long as possible, and they also prefer to receive long-term care services in their home instead of in an assisted living facility or nursing home (1997). Even as people experience physical and cognitive functional declines, they still indicate that housing is the most desirable setting to receive care and monitoring (AARP, 2000).

Why do so many people want to remain in their homes as they age and even as they experience health declines? Many people in the older population have a negative perception

of moving to nursing homes, viewing it as an unhappy experience that will result in them losing autonomy and important life values (Rentz, Boltz, & Capezuti, 2004). Options for medical care at home may also encourage people to stay home rather than move to a nursing home or other institution. “For many older adults, home-based services are a viable alternative to [nursing home] placement” (Marek et al., 2005).

Costs and Longevity

The cost of staying at home vs. moving to an institution also factors into the decision. Healthcare costs are rising, and the length of life for people with health problems is increasing (Administration on Aging, 2012). Home-based care is often the most affordable option. Affordable care is key since life expectancy continues to increase. “Persons reaching age 65 have an average life expectancy of an additional 19.2 years (20.4 years for females and 17.8 years for males)” (Administration on Aging, 2012). Modifying the homes of people, especially those in the aging population, can make it easier and possible to remain at home.

Home modification is “one of key elements in meeting the needs of older people and creating supportive environments conducive to aging-in-place” (Hwang, Cummings, Sixsmith, & Sixsmith, 2011). In fact, Hwang et al. reported that the built environment was directly tied to the level and quality of aging people’s daily activity and life (2011). Home modifications, which are defined as modifying permanent features in the indoor or immediate outdoor home environment to increase the accessibility of home environments, have many benefits, “including enhanced accessibility and usability of home environments, strengthened personal and social meaning of home for older people, lessened dependence in performing daily activities, and reduced burden on caregivers” (Hwang et al., 2011). Hwang et al.’s study and previous studies indicate that older people who had home modifications done were

likely to stay longer at their existing housing than those who did not (Gitlin et al.,1999; Hutchings, Olsen, & Moulton, 2008; Pynoos & Liebig,1995, as cited in Hwang et al., 2011). Hwang et al.'s study also shows how home modifications had positive effects on the quality of life for older adults and task performance at home (2011). However, the cost of modifications (perceived or real) deters many older people from making changes to their homes, even when income is controlled (Gliderbloom & Markham, 1996).

Statement of the Problem

The problem this research and design investigates is the United States' growing population of aging people with increasing disabilities, and their desire to remain living at home as they age despite most homes being designed to accommodate able-bodied people. Many people with disabilities will have difficulty maintaining full function, mobility, and engagement due to environmental barriers in their homes. To maintain independence and quality of life, home modifications will be necessary for those who wish to remain living in their home. While a universally designed home would be ideal to meet the needs of all people and abilities, it is often expensive to modify an existing home to meet all the principles of universal design. People will need to evaluate their individual present and potential future needs, lifestyle, expected length of time they will live in their homes, and budget to prioritize modifications to best meet their unique situation.

Purpose of the Study

The purpose of the study is to identify how people who are aging and anticipating future disabilities, or living with limitations or disabilities, can plan home modifications to fit their unique situation, needs, and budget.

Hypothesis

If a fully universal designed home is unattainable or unrealistic, it is still possible to achieve a functional, accommodating home for aging in place by prioritizing modifications to best meet the individual homeowner's needs, lifestyle, and budget.

Significance of the Study

This study is significant because of the millions of people in the United States who are aging, want to remain living in their homes, and want to make modifications to their homes to accommodate them as they age and develop disabilities. Not everyone can afford to make their home fully accessible or universal, especially in an existing home, so it is important for people to be able to tailor their home modification to best fit their individual needs to help maintain maximum independence, quality of life, and ability to remain living at home.

Limitations of the Study

This qualitative case study is limited in that it explores only one family's specific needs, lifestyle, and budget. Other individuals could have much different abilities, modification needs, expected length of life, scope of modifications, and budget, all of which would affect the design decisions.

Chapter 2: Review of Related Literature

Aging in Place

“Aging in place” is a popular term in current aging policy, defined as “remaining living in the community, with some level of independence, rather than in residential care” (Davey, Nana, de Joux, & Arcus, 2004, p. 133). People today are more often choosing to age in place because they believe continuing to live at home will allow them to maintain independence, autonomy, and connection to friends, family, and other social support (e.g., Callahan, 1993; Keeling, 1999; Lawler, 2001). These connections are vital to older people. “Social support is independently related to mortality, and quality of social contacts has been shown to ameliorate the negative impacts of past and immediate environments” (Wiggins, Higgs, Hyde, & Blane, 2004, as cited in Wiles, 2012, p. 358), although this varies significantly by ethnic group (Moriarty & Butt, 2004, as cited in Wiles, 2012, p. 358).

For older people especially, the symbolism and meaning of home is strong. “Homes are physical but also operate on social and symbolic levels in interconnected ways” (Rowles, 1993). Older people’s sense of attachment to place associates home with meaning and security (Rowles, 1993). “Long-term emotional attachments to environmental surroundings have also been shown to contribute to well-being in old age” (Wiles, 2012, p. 358, citing Rubinstein, 1990 and Taylor, 2001), “although residential stability may not always be emotionally beneficial, such as when older people are unable to move away” (Wiles, 2012, p. 358, citing Aneshensel et al., 2007). Many people who prefer to remain in their homes as they age associate it with independence and autonomy (Wiles, 2012, p. 363). “Often this was as much about not wanting to be in a nursing home or institution, where it was perceived that autonomy might be lost as about remaining in the same place” (Wiles, 2012, p. 363).

“Aging in place” was seen as an advantage in terms of a sense of attachment or connection, practical benefits of security and familiarity, and as being related to people’s sense of identity through independence and autonomy. Attachment and connection operated at social and community levels; they were not just linked to a particular house” (Wiles, 2012, p. 364).

“The ideal of aging in place continues to struggle with realities that prevent its fulfillment” (Moody, 2008, p.151). In Wiles’ focus groups and interview with older people, they expressed a strong desire to make their own choices about where to live, and having enough money to make those choices was also an issue for many of the subjects (Wiles, 2012, p. 364). Older people strongly prefer to age in place, and it is an important goal of public policy (Moody, 2008, p.151). Even though remaining in the home and community for as long as possible avoids or delays the cost of institutional care and is therefore favored by policy makers, health providers, and many older people themselves, (Wiles, 2012, p. 357), policies to promote [aging in place] are not always in effect” (Moody, 2008, p.151). Moody writes:

Aging in place continues to be hindered by inaccessible and unsupportive housing, pushing frail older people towards undesired settings such as nursing home.

Environmental gerontologists have argued that where people grow old matters and aging does not take place in some situational, contextual, or environmental vacuum. (2008, p.151)

The existing programs that support aging in place, such as federal initiatives that include the Program for All Inclusive Care for the Elderly (PACE) and Social Health Maintenance Organizations, report positive outcomes (Eng, Padulla, Eleazer, McCann, & Fox, 1997, as cited in Marek et al., 2005, p. 203). These programs coordinate healthcare for

individuals who are certified as [nursing home] eligible but are able to live safely in the community (Eng, Padulla, Eleazer, McCann, & Fox, 1997, as cited in Marek et al., 2005, p. 203). “Providers are paid at a capitated rate based on Medicare and state Medicaid rates. Outcomes of PACE programs have been positive, including good consumer satisfaction, reduction in use of institutional care, and cost savings to public and private payers of care” (Eng, Padulla, Eleazer, McCann, & Fox, 1997, as cited in Marek et al., 2005, p. 203). Compared to people who chose not to participate in PACE, PACE participants demonstrated a higher level of ADL (activities of daily living) functioning ($p < .10$) after 24 months and self-reported quality of life after 6 months ($p < .10$)” (Chatterji, Burstein, Kidder, & White, 1998, as cited in Marek et al., 2005, p. 202).

While there are proven benefits to aging in place and most older people want to remain living in their homes, it seems that more or better policies need to be developed so all older people have the option to age in place.

Psychological and Social Factors of Aging in the Built Environment

No matter where people choose to live as they age, the design of the building plays a role in quality of life, health, and longevity. Depending on how it is designed, a home’s characteristics can help or impair aging people’s function by removing or creating barriers to their daily tasks (Wahl et al., 2009, as cited in Carr et al., 2013). The environment surrounding older adults at home and in the community is the primary factor that creates opportunities and constraints for them (Rowe & Kahn, 1987, as cited in Carr et al., 2013).

If a person’s home is limiting, modifications can impact engagement and promote a healthier, more satisfying aging experience (Rowe & Kahn, 1997, as cited in Carr et al., 2013). “. . . environments that are thoughtfully designed or modified to accommodate

varying abilities have the potential to reduce disability and foster engagement in social and productive activities in later life” (Carr et al., 2013, citing Liu & Lapane, 2009 and Verbrugge & Jette, 1994). It is important for designers to consider the changes that take place as people age because the built environment has such a big impact on daily functioning for older adults (Demirbilek & Demirkan, 2004, as cited in Carr et al., 2013). Homes and other environments that accommodate people of different abilities can increase their well-being, quality of life, and ability to participate in activities (Guse & Masesar, 1999, and Grundy & Bowling, 1999, as cited in Carr et al., 2013).

Staying active and social is enjoyable for aging adults, and beneficial, too. Engagement in social, intellectual, cultural, leisure, and productive pursuits has been linked to increases in health (Fone & Lundgren-Lindquist, 2003, as cited in Carr et al., 2013). People who report higher levels of social engagement in any activity are significantly less likely to need health services and are prescribed less medication (Bath & Gardiner, 2005, as cited in Carr et al., 2013), and people who participate in social, productive, and physical activities have increased objective and subjective health, reductions in all causes of mortality, and reductions in loneliness and depression (Brown, McGuire, & Voelkl, 2008, Bennett, 2005, Gliderbloom & Markham, 1996, & Grundy & Bowling, 1999, as cited in Carr et al., 2013). Maintaining a continued engagement in life can also help older adults maintain well-being and quality of life after experiencing negative events such as suffering from functional loss and losing a spouse (Silverstein and Parker, 2002, as cited in Carr et al., 2013).

Even though the process of home modification can be costly and stressful, it is easier and more successful to adapt the home than to try to adapt the homeowner. Designing and modifying the built environment to be inclusive increases people’s functional abilities with

the least amount of effort required from the individuals, compared to approaches attempting to change the people (i.e., exercise to increase strength to operate a regular door) or provide assistive tools (i.e., provide an electronic push button to open the door; Story, 1998, as cited in Carr et al., 2013).

Accessible Design and the Americans with Disabilities Act Accessibility Guidelines (ADAAG)

The Americans with Disabilities Act [ADA] is a civil rights law enacted in 1990 that provides protection to people with disabilities in the United States (J. Stein, 2004). The Dictionary of American History, 3rd edition, states that the ADA

[mandates] accessibility and reasonable accommodations and [prohibits] disability-based discrimination in state and local government services, public transit, telecommunications, and public places (restaurants, stores, theatres, private schools, hospitals, and other entities offering the public goods and services). (M. Stein, 2002)

The ADA is a complaint-driven law, which means it is “enforced by private citizens who either file a complaint with the appropriate federal agency responsible for enforcement or file a lawsuit in federal court” (J. Stein, 2004). The Americans with Disabilities Act Accessibility Guidelines [ADAAG] describe and illustrate the ADA requirements for buildings, but the ADAAG are not building codes (J. Stein, 2004). “Because ADA is a civil rights law, there are many aspects of the technical requirements that differ from standard building codes” (J. Stein, 2004). Single and two-family homes are generally not required to comply with the ADA (NAHB Research Center, 2000), but for people with physical or mental limitations, the ADAAG is helpful for reference and guidance when looking to buy an accessible home or modifying an existing home to be accessible.

While accessible design and the ADA are truly beneficial to people with disabilities, it is important to note that accessible design is different from universal design. Accessible design is “the design of entities that satisfy specific legal mandates, guidelines, or code requirements with the intent of providing accessibility to the entities for individuals with disabilities” (Erlandson, n.d.) Accessible design focuses on providing access for people with disabilities, and often elements of accessible design stand out visually and look institutional. Universal design focuses on design for people of all ages and abilities, focusing on inclusion and equality and integrated accessibility that is not noticeable (Demirkan, 2008 and Story, 1998, as cited in Carr et al., 2013). The Center for Universal Design further describes accessible design features:

Accessible features in dwellings include items such as wide doors, sufficient clear floor space for wheelchairs, lower countertop segments, lever and loop type handles on hardware, seats at bathing fixtures, grab bars in bathrooms, knee spaces under sinks and counters, audible and visual signals, switches and controls in easily reached locations, entrances free of steps and stairs, and an accessible route through the house. Most “accessible” features are permanently fixed in place and very apparent. (2006).

Universal Design

While often associated with accessible design, universal design is a philosophy that goes beyond accessibility and strives to be inclusive of people of all abilities. “Universal design is founded on the premise that there is only one population with varying characteristics rather than a ‘normal’ and ‘diverging from normal’ population” (Iwarsson & Ståhl, 2003, as cited in Carr et al., 2013). Universal design includes environments and

products that are more easily accessed and used by people of different abilities without specialized adaptations (Story, 1998, as cited in Carr et al., 2013). It aims to provide accessibility without stigmatization, focusing on inclusion and equality, by integrating accessibility features that benefit all users without being noticeably accessible (Demirkan, 2008 and Story, 1998, as cited in Carr et al., 2013).

The principles of universal design, as described in Story, Mueller, & Mace's *The Universal Design File* for The Center for Universal Design, are:

1. Equitable Use

The design is useful and marketable to people with diverse abilities.

Guidelines:

- 1a. Provide the same means of use for all users: identical whenever possible; equivalent when not.
- 1b. Avoid segregating or stigmatizing any users.
- 1c. Make provisions for privacy, security, and safety equally available to all users.
- 1d. Make the design appealing to all users.

2. Flexibility in Use

The design accommodates a wide range of individual preferences and abilities.

Guidelines:

- 2a. Provide choice in methods of use.
- 2b. Accommodate right- or left-handed access and use.
- 2c. Facilitate the user's accuracy and precision.
- 2d. Provide adaptability to the user's pace.

3. Simple and Intuitive Use

Use of the design is easy to understand, regardless of the user's experience, knowledge, language skills, or current concentration level.

Guidelines:

- 3a. Eliminate unnecessary complexity.
- 3b. Be consistent with user expectations and intuition.
- 3c. Accommodate a wide range of literacy and language skills.
- 3d. Arrange information consistent with its importance.
- 3e. Provide effective prompting and feedback during and after task completion.

4. Perceptible Information

The design communicates necessary information effectively to the user, regardless of ambient conditions or the user's sensory abilities.

Guidelines:

- 4a. Use different modes (pictorial, verbal, tactile) for redundant presentation of essential information.
- 4b. Maximize "legibility" of essential information.
- 4c. Differentiate elements in ways that can be described (i.e., make it easy to give instructions or directions).
- 4d. Provide compatibility with a variety of techniques or devices used by people with sensory limitations.

5. Tolerance for Error

The design minimizes hazards and the adverse consequences of accidental or unintended actions.

Guidelines:

- 5a. Arrange elements to minimize hazards and errors: most used elements, most accessible; hazardous elements eliminated, isolated, or shielded.
- 5b. Provide warnings of hazards and errors.
- 5c. Provide fail safe features.
- 5d. Discourage unconscious action in tasks that require vigilance.

6. Low Physical Effort

The design can be used efficiently and comfortably and with a minimum of fatigue.

Guidelines:

- 6a. Allow user to maintain a neutral body position.
- 6b. Use reasonable operating forces.
- 6c. Minimize repetitive actions.
- 6d. Minimize sustained physical effort.

7. Size and Space for Approach and Use

Appropriate size and space is provided for approach, reach, manipulation, and use regardless of user's body size, posture, or mobility.

Guidelines:

- 7a. Provide a clear line of sight to important elements for any seated or standing user.
- 7b. Make reach to all components comfortable for any seated or standing user.
- 7c. Accommodate variations in hand and grip size.
- 7d. Provide adequate space for the use of assistive devices or personal

assistance. (© 1998, p.34-35)

Universal design's inclusive and equal qualities differentiate it from accessible design and create the potential to further enhance well-being and quality of life (Crews & Zavotka, 2006, as cited in Carr et al., 2013). "Universal design may have the potential to affect older adult's engagement with life, by providing accessible and accommodating environments in which this population can thrive without stigmatization" (Carr et al., 2013). Implementing universal design in people's homes could allow aging adults to complete their activities of daily living independently and maintain a safer environment, possibly reducing the chances of or delaying the necessity of relocating to a nursing home (Crews & Zavotka, 2006 and DeMerchant & Beamish, 1995, as cited in Carr et al., 2013).

Universal design can create safe, accessible, and functional environments for a wide variety of people and abilities (Kose, 1998, as cited in Carr et al., 2013), and empirical evidence supports the success of universal design in application (Carr et al., 2013). When 24 people with varying disabilities or no disabilities toured a universally designed building and a non-universally designed building, every person reported that s/he had less difficulty and required less effort and assistance to complete standard tasks (such as finding a public washroom and entering the building) in the building constructed using universal design principles (Danford, 2003, as cited in Carr et al., 2013).

While universal design is not currently a legal building code, it should still be utilized as good practice because it incorporates building code requirements and goes beyond to provide equal use and accessibility for people of many different abilities (Carr et al., 2013). Universal design is more than accessible design; rather, it emphasizes democracy and

equality for everyone, including the growing older adult population (Iwarsson & Ståhl, 2003, as cited in Carr et al., 2013).

If universal design is inclusive of and beneficial to all people, why are most new buildings and homes designed without meeting the universal design principles? The main challenge for universal design is that there is not much education in the importance and application of universal design provided to engineers, designers, and planners, and there is little consensus or consistency in universal design's definitions (Aslaksen et al., 1997 and Iwarsson & Ståhl, 2003, as cited in Carr et al., 2013). In addition, universal design has not yet been adopted as a best practice, and its principles are often overlooked while norms and codes take precedence when design decisions are made (Aslaksen et al., 1997, as cited in Carr et al., 2013, and Carr et al., 2013).

Also, it is challenging to create and implement designs that meet the needs of such a broad spectrum of people and abilities, and it is especially difficult to do so if designers do not fully understand the barriers that the end-users will experience (Keates et al., 2000, and Hall & Imrie, 1999, as cited in Carr et al., 2013). Another hurdle for universal design is that there are different opinions on the cost of implementing universal design. While people in academia report that it can be implemented with little or no additional cost, the designs often require more square feet, which increase construction costs (Story, 1998 and Commission for Architecture and the Built Environment, 2008, as cited in Carr et al., 2013). Finally, the client has the final say in what gets implemented, so if the client is not convinced of the merits of universal design and does not approve its implementation, the designer cannot force universal design principles into the design (Carr et al., 2013).

Universal design can move forward if it is increasingly taught and emphasized in architecture, design, engineering, and planning curricula, if its principles and merits are communicated to clients during the design process so they understand and will possibly approve its implementation in their designs, if professionals can work together to create a best practice guideline which would exceed minimum code requirements, and if more cost-effective ways to implement universal design are developed to make it more affordable for clients and therefore more likely for clients to agree to implement it in their projects (Demirbilek & Demirkan, 2004, as cited in Carr et al., 2013).

“. . . universal design strives to provide accessible environments without stigmatization or ageism, as the design principles are not specialized and are incorporated into the environment in the initial stages of planning” (Carr et al., 2013, citing Story, 1998, Demirkan, 2007, and Verbrugge & Jette, 1994). While many universally designed buildings and homes were planned to be universally designed, it is possible to modify an existing structure to meet the universal design principles. Modifying a home to universal design standards is often more expensive and challenging than building a new home that is planned with universal design principles from the beginning, but for many homeowners, the benefits of a universally designed home are well worth the extra investment. Homeowners need to assess their needs and options to determine whether a universal design modification is the best choice for them.

Amyotrophic Lateral Sclerosis (ALS)

Amyotrophic lateral sclerosis [ALS], the disease of one of the case study subjects is living with, is defined by the National Institute of Neurological Disorders and Stroke [NINDS] as “a rapidly progressive, invariably fatal neurological disease that attacks the

nerve cells (neurons) responsible for controlling voluntary muscles. The disease belongs to a group of disorders known as motor neuron diseases, which are characterized by the gradual degeneration and death of motor neurons” (2012). ALS is further described by the ALS Association [ALSA]:

The disorder causes muscle weakness and atrophy; symptoms commonly appear in middle to late adulthood, with death in two to five years. The cause is unknown, and there is no known cure. Also called Lou Gehrig's Disease, or Motor Neuron Disease. Literally, amyotrophic lateral sclerosis means without muscle nourishment, side (of spinal cord) hardening. (2013a)

Weakness and increasing disabilities occur with ALS, and eventually all voluntary muscle control is affected or lost (NINDS, 2012). Muscle weakness or stiffness often occurs in the onset of ALS, progressing to “wasting and paralysis of the muscles of the limbs and trunk as well as those that control vital functions such as speech, swallowing and later breathing” (ALSA, 2013b), although the order of affected areas can vary. “When muscles in the diaphragm and chest wall fail, patients lose the ability to breathe without ventilatory support” (NINDS, 2012). Because of the breathing difficulties, most people with ALS die from respiratory failure, and this most often occurs three to five years after symptoms begin, but approximately ten percent of ALS patients survive for ten years or longer (NINDS, 2012). There are often months or even years between symptom onset and diagnosis. Despite the grim prognosis, the ALS is different for each person, and “many people live with quality for five years and more. More than half of all patients live more than three years after diagnosis” (ALSA, 2013b). No matter how long patients survive with ALS, “there can be

significant costs for medical care, equipment and home health caregiving later in the disease (ALSA, 2013b), and that does not include lost wages from interrupted careers.

Symptoms and progression. Onset of ALS can have varying symptoms, but 60% of patients experience muscle weakness initially (ALSA, 2013e). Other early symptoms include “tripping, dropping things, abnormal fatigue of the arms and/or legs, slurred speech, muscle cramps and twitches and/or uncontrollable periods of laughing or crying” (ALSA, 2013e). Hands or feet may be affected first, “causing difficulty in lifting, walking or using the hands for the activities of daily living such as dressing, washing and buttoning clothes” (ALSA, 2013e). As the disease spreads to the body’s trunk muscles, it affects speech, swallowing, and breathing, at which point “the patient will need permanent ventilatory support in order to survive” (ALSA, 2013e). ALS affects motor neurons, so the senses (sight, touch, hearing, taste, and smell) are not affected, and eye and bladder muscles are usually not affected (ALSA, 2013e). However, a person who cannot move due to paralysis of the other muscles will find it difficult or impossible to get to a bathroom even if the bladder muscles are functioning (NINDS, 2012). The ALSA describes one progression of ALS:

- muscle weakness in one or more of the following: hands, arms, legs or the muscles of speech, swallowing or breathing
- twitching (fasciculation) and cramping of muscles, especially those in the hands and feet
- impairment of the use of the arms and legs
- "thick speech" and difficulty in projecting the voice
- in more advanced stages, shortness of breath, difficulty in breathing and swallowing (2013e)

The sequence of symptom onset and the rate at which ALS progresses is different in each person (NINDS, 2012). As the disease progresses, patients cannot stand, walk, get in or out of bed or chairs independently, use their hands, or use their arms; as swallowing and chewing become difficult, choking risk increases and it can be difficult for patients to maintain weight as eating turns into a laborious task (NINDS, 2012). Once eating and/or breathing become difficult, some patients choose to extend life with a feeding tube or ventilator, and a new option, a pacemaker for the lungs, can extend life approximately 18 months.

Mental and intellectual effects. Even though ALS paralyzes the physical body, it usually does not affect the mind or intelligence (NINDS, 2012). “Patients are aware of their progressive loss of function and may become anxious and depressed. A small percentage of patients may experience problems with memory or decision-making, and there is growing evidence that some may even develop a form of dementia” (NINDS, 2012). Some of these cases of ALS involve Frontotemporal Lobar Dementia [FTLD], a progressive and irreversible condition separate from Alzheimer’s disease that degenerates and atrophies the brain’s frontal and anterior temporal lobes, causing “personality changes, language difficulty, or behavioral disturbance” (Lomen-Hoerth, 2012, p. 18). In addition, recent studies indicate changes in cognitive functions, “such as depression and problems with decision-making and memory” (NINDS, 2012), in some ALS patients. Because of these mental and emotional difficulties, it is important for patients’ doctors to honestly and clearly explain the course of ALS and the available treatment options so patients can make important, informed decisions in advance (NINDS, 2012).

Who gets ALS? Approximately 5,600 people in the United States are diagnosed with ALS each year (15 new cases per day), and an estimated 30,000 Americans currently have ALS (ALSA, 2013f). “According to the ALS CARE Database, 60% of the people with ALS in the Database are men and 93% of patients in the Database are Caucasian” (ALSA, 2013f). The majority of people who develop ALS are middle aged, between age 40 and 70, and average age 55 when they are diagnosed (ALSA, 2013f). A minority of people develop ALS while still in their twenties and thirties (ALSA, 2013f). 20% more men than women develop ALS, but this gets more equal as age increases (ALSA, 2013f).

90-95% of ALS cases in the United States are classified as sporadic [SALS] (ALSA, 2013d). Sporadic ALS patients have no family history of ALS and are isolated cases of the disease in their families, but researchers believe there is a most likely a genetic predisposition involved in these cases (ALSA, 2013d). 5-10% of ALS cases are familial [FALS], meaning they have occurred more than once in the patients’ family lineage and are therefore genetic (ALSA, 2013c). FALS “usually results from a pattern of inheritance that requires only one parent to carry the gene responsible for the disease” (NINDS, 2012). Children of people with FALS have a 50% chance of inheriting the gene mutation that causes ALS in their family and may develop ALS (ALSA, 2013c). There seems to be a link between FALS and FTLD [Frontotemporal Lobar Dementia], because while only 5-10% of ALS cases are classified as familial, 40% of FTLD cases occur in familial ALS patients, and members of families with FALS and FTLD may have one or both diseases (Lomen-Hoerth, 2012, p. 20). This “suggests a relationship in the pathogenesis of these 2 disorders” (Lomen-Hoerth, 2012, p. 20).

Another form of ALS is Guamanian ALS, the type of ALS people developed at an extremely high incidence in Guam and the Trust Territories of the Pacific in the 1950s (ALSA, 2013c). Beyond the genetic component of FALS, several studies are investigating possible risk factors that may affect who develops ALS (ALSA, 2013f). “More work is needed to conclusively determine what genetics and/or environment factors contribute to developing ALS. It is known, however, that military veterans, particularly those deployed during the Gulf War, are approximately twice as likely to develop ALS (ALSA, 2013f).

Chapter 3: Research Design and Methodology

The method for this research was a qualitative case study. Two subjects, spouses, were interviewed in March 2014. Subject 1 is in his/her early 60s and was diagnosed with ALS in 2010. S/he currently has full mobility but can no longer speak, chew, or swallow. S/he communicates by typing or by hand-writing notes and uses a feeding tube to eat. Subject 2, the spouse, is also in his/her early 60s and is in good health. Both subjects are retired, and Subject 2 plans to be the primary caregiver as Subject 1's needs increase.

The subjects' home was evaluated and compared to ADAAG and Universal Design Guidelines to establish areas that could be difficult for independent functioning or mobility.

The interview questions were:

1. How do you feel about your home now? This can relate to emotional or psychological feelings and/or feelings about specific parts of your home.
2. What things and/or areas in your home would you like to change?
3. What are your goals for your home in this design?
4. What kind of feeling, aesthetic, style, and/or quality are you hoping to have in your home?
5. Describe the financial issues of a couple in your situation and/or stage of life.
6. What is your budget for this project, and how flexible is the budget?
7. What are your priorities in the design that will help direct where the budget is focused?
8. Where do you want to live as you age and as your abilities change?

Chapter 4: Results and Discussion

Interview

In response to Question 1 (How do you feel about your home now?), Subject 1 (the person living with ALS) said s/he fell in love with the home as soon as s/he stepped inside the door (personal communication, March 26, 2014). The subjects were already focused on aging in place when they were house hunting and only considered ranch homes. The biggest selling point of the house was a great room that has large windows with views of trees outside (Subject 1, personal communication, March 26, 2014). The subject was happily surprised to find such a natural site for a home within city limits and conveniently close to many amenities (Subject 1, personal communication, March 26, 2014). Subject 1 stated that s/he still loves the home and wants to live in it for the rest of his/her life, but notes that the home needs some modifications to make it livable as both spouses age (personal communication, March 26, 2014). S/he stated that s/he would like a zero step entry into the home and a more accessible full bathroom and master bedroom, as the current master suite, while spacious, is located on the lower level (Subject 1, personal communication, March 26, 2014).

Subject 2 (the spouse) responded to Question 1 establishing how s/he and his/her spouse like that their home is in an ideal setting in their city, is in a friendly neighborhood, and has high quality construction and materials (personal communication, March 26, 2014). S/he really likes feeling like s/he is in the woods when s/he looks out the great room windows even though the house is so close to services and stores in the city (Subject 2, personal communication, March 26, 2014).

In response to Question 2 (What things/areas would you like to change in your home?), Subject 1 said:

I wish our “new” master bedroom and bath were on the main floor. The master bath is huge, and would be such a sweet accessible suite if it wasn’t on the lower level. I have an illness that impairs and kills relatively quickly (in a few years, not decades), so I do not feel it is worth the cost to install mechanics that would let me get upstairs and downstairs via wheelchair (personal communication, March 26, 2014).

Subject 2 responded that s/he would like to have no steps to get into the house from the outside and a stair-free way to easily move between the first and lower levels of the home since there is a lot of interior finished space on the lower level, including the laundry room, master suite, and an exterior deck (personal communication, March 26, 2014). S/he noted that if it is not feasible to modify the home to have a stair-free way to move between the first floor and lower level, s/he would like to turn one of the bedrooms on the first floor into the master bedroom, and modify the first floor full bath to be step-free as well (Subject 2, personal communication, March 26, 2014).

In response to Question 3 (What are your goals for your home in this design?), Subject 1 said, “I am moving through a progressive, terminal illness – ALS – and although I can still walk, I expect I will lose that muscle power eventually. But before I become wheelchair-bound, I want a bathroom that makes care and cleanliness as trouble-free as possible” (personal communication, March 26, 2014). The subject recalled that a family member, who also had ALS, was able to get around most of the first floor in his wheelchair, but the existing shower in the first floor bathroom did not have room for the wheelchair and he had to be held up in a standing position while he showered (Subject 1, personal

communication, March 26, 2014). Subject 1 concluded that the existing first floor full bathroom's small shower with a curb and glass walls might work for most people, but it is difficult to use for people who cannot walk or stand alone (personal communication, March 26, 2014). Subject 1 shared that s/he wants a bathroom that can meet his/her future needs and those of others who use the bathroom, and stated that s/he wants to be able to help him/herself around the house as easily and often as possible (personal communication, March 26, 2014). Subject 1 stated:

For those times when I need assistance, I also want a bath environment that makes caring for me as easy as it can be. But I do not want this bath to look like one taken out of a hospital or nursing home. I want it to look stunning, and work well for everyone, not just someone with impairment. (personal communication, March 26, 2014)

Also in response to Question 3, Subject 2 stated that the kitchen and bathrooms need updates for aesthetic appeal and to make it easier for his/her spouse to use the spaces as his/her ALS progresses (personal communication, March 26, 2014). "It is important that our home works for us in our current situation. Easy, step-free access into the house, and the ability to maneuver a wheelchair throughout the house are requirements. Still, we don't want the house's appearance to shout 'handicapped accessible'" (Subject 2, personal communication, March 26, 2014).

Subject 1 stated, in response to Question 4 (What kind of feeling, aesthetic, style, and/or quality are you hoping to have in your home?), that s/he appreciates the high quality of the existing cabinetry, flooring, and overall design (personal communication, March 26, 2014). S/he liked that a past remodel and expansion of the home made it feel more open, with

a great room feel that s/he has always loved (Subject 1, personal communication, March 26, 2014). S/he said, “I want my home to make people feel welcome, at ease, and fun-loving. My tastes run contemporary-comfortable. And this home has the bones to pull that off” (Subject 1, personal communication, March 26, 2014).

In response to Question 4, Subject 2 expressed that s/he wants his/her home to be contemporary, warm, and welcoming, with well-made fixtures and equipment (personal communication, March 26, 2014). S/he said that quality fixtures and equipment will be important for resale value in the future (Subject 2, personal communication, March 26, 2014).

Subject 1 answered Question 5 (Describe the financial issues of a couple in your situation and/or stage of life) stating that s/he and his/her spouse maintained a fair income thanks to retirement benefits and insurance (personal communication, March 26, 2014). However, they have to pay a lot of money out of pocket to pay for expensive ALS-related medications (Subject 1, personal communication, March 26, 2014). The subjects aim to spend wisely and carefully to avoid depleting their savings too quickly (Subject 1, personal communication, March 26, 2014).

In response to Question 5, Subject 2 said, “We’re living on retirement income, dealing with ongoing medical costs for [Subject 1], and facing the uncertainty of how and how fast [his/her] ALS will progress” (personal communication, March 26, 2014).

Subject 1 responded to Question 6 (What is your budget for this project, and how flexible is the budget?), stating:

By providing our own labor, we anticipate spending about \$10,000 to \$13,000 in materials for this bathroom. In my quest to make it both attractive and accessible, we

have found some of the most attractive elements come at designer prices, a tough realization for two retirees. But we are finding ways to save money without sacrificing style. And when it is done, it will be well worth the time and energy we spent to get it installed. (personal communication, March 26, 2014)

Subject 2 responded to Question 6, stating that while s/he wants to enhance the quality of his/her home and modify it to meet their needs, s/he doesn't want to over-improve the house beyond the selling price the neighborhood can command (personal communication, March 26, 2014).

In response to Question 7 (What are your priorities for the project that will help direct where the budget is focused?), Subject 1 stated that three zones were the most important for modifications: the shower, which s/he wants to be big enough to fit a wheelchair and a caregiver; an efficient toilet with a washlet "for good hygiene even when arms and legs no longer function," and a sink that a person can approach and reach from a wheelchair (personal communication, March 26, 2014). S/he views the first floor full bathroom as the priority for the design budget, and wants it to turn into more of a wow factor for visitors (Subject 1, personal communication, March 26, 2014).

Subject 2, in answering Question 7, said:

When looking at remodeling possibilities, anything is possible if cost is no object. In reality, we know we must achieve maximum functionality for daily living with limited expenditure, perhaps following with more changes as a 2nd and 3rd phase. In making changes in one's home, it is essential to do it right in terms of safety, durability over time, current usability, and future flexibility as needs change (personal communication, March 26, 2014).

Subject 1 answered Question 8 (Where do you want to live as you age, your abilities change, etc.?) stating that s/he is thankful that it is now easier to remain at home through illness or aging (personal communication, March 26, 2014). While s/he believed most people would choose to age in place instead of move to a nursing home, s/he observed that many people's home environments work against them as they develop disabilities (Subject 1, personal communication, March 26, 2014). S/he preferred to stay in his/her own home because s/he wanted to maintain a sense of control (Subject 1, personal communication, March 26, 2014). However, s/he realizes that at some point his/her family may have to choose to move him/her to a residential care location (Subject 1, personal communication, March 26, 2014).

Subject 1 explains why s/he would not like living in a nursing home vs. his/her existing home:

No nurse's aide in an institution has the time or focus to give individual attention.

Moving to a nursing home means someone else decides when you sleep, eat, wash up, shower, toilet, and socialize, if you are still able. (Personal communication, March 26, 2014).

S/he recalled having to make the same choice to put a family member in a nursing home (Subject 1, personal communication, March 26, 2014), and stated:

I am very likely to live out most of my days at home, because I have a loving spouse and caring children who know a lot about ALS. No, the bigger challenge will be for my widowed [spouse]. Without a spouse, a person's safety net is essentially more tattered, and the end-of-life options are significantly different. (Subject 1, personal communication, March 26, 2014)

Subject 2 responded to Question 8 stating that s/he would prefer to live at home as s/he ages or possibly buy and move to a condo if maintaining his/her home becomes too much of a burden (personal communication, March 26, 2014). S/he said it would be hard to give up the ability to work on the home as s/he pleases if s/he moved to a condo, so s/he preferred to have (and live in) a house that will allow him/her to continue doing his/her favorite activities as his/her strength declines and will provide an accommodating, attractive setting if s/he needs more assistance as s/he ages (Subject 2, personal communication, March 26, 2014). S/he stated that as his/her mental and/or physical abilities decline, s/he would want in-home caregivers so s/he could maintain personal control of his/her life as long as possible. S/he accepts that s/he may eventually need to move to a healthcare facility, but s/he rues that in that case, s/he will lose some control of his/her daily schedule and activity choices (Subject 2, personal communication, March 26, 2014). S/he recalls witnessing a family member linger in nursing homes for many years, and hopes s/he does not have to go through that (at least not for very long), since s/he will hate having to have nursing staff wake, move, and feed him/her, take him/her to the bathroom, etc., all according to the facility's schedule (Subject 2, personal communication, March 26, 2014).

Home Analysis

The researcher assessed the subjects' home in relation to universal design principles to help determine any necessary modifications. The first floor hallway, at 45" wide, is wide enough for most people to maneuver through (equitable use, size and space for approach and use). However, most interior doors are 32" wide, narrower than the 36" width recommended for wheelchair accessibility in the ADAAG (does not meet equitable use, size and space for approach and use, or tolerance for error). Most of the main living areas have wide openings

instead of doors, and are easy for all people to get in and out of (equitable and size and space for approach and use). The interior rooms have ample space for maneuvering in an assistive mobility device, such as a wheelchair, as long as furniture is thoughtfully placed (equitable use and size and space for approach and use).

The kitchen is large with generous widths ranging from 36"-78" between the perimeter counters and the island (size and space for approach and use). However, the kitchen has some potential barriers that include the following: counters, currently 36-1/2" high instead of the maximum 34-1/2" height recommended in the ADAAG (does not meet equitable use or flexibility in use); lack of areas a person in a seated position could pull under to prepare or serve food (does not meet equitable use or size and space for approach and use); upper cabinets that are not reachable for shorter people, people with limited reach or mobility, or people in a seated position (does not meet equitable use or flexibility in use); some lower cabinets that require low, deep reaching, difficult for taller people and people with limited reach or mobility (does not meet equitable use or flexibility in use); sinks that are not easily accessed by a person in a wheelchair (does not meet equitable use, flexibility in use, or size and space for approach and use); stove light and exhaust fan switches that are higher than people in a seated position or people with limited reach could access (does not meet equitable use, flexibility in use, or low physical effort); oven controls that are higher than people in a seated position or people with limited reach could access (does not meet equitable use, flexibility in use, or low physical effort); knobs on the cabinets and drawers which are difficult to operate for people with limited fine motor abilities (does not meet equitable use, flexibility in use, or low physical effort). The stove's controls are at the front, which is easy for most people to reach (low physical effort) but could pose a danger for

children or people with limited cognitive abilities as the knobs can easily be turned to start the gas or turn on the burners (does not meet tolerance for error).

The entries to the home all have at least two steps, which are not equitable for people with limited mobility. The first floor hallway and living room and all of the bedrooms have wall-to-wall plush carpeting, which could be difficult to maneuver on in a mobility device such as a wheelchair (does not meet equitable use or low physical effort). The first floor powder room has a 24” wide door, a 24” clearance between the toilet and the vanity, and a total width of 39”, all of which prove difficult to access or maneuver in even for people with no disabilities (does not meet equitable use or size and space for approach and use).

The first floor full bathroom has barriers for people with limited mobility and fine motor skills in the following elements: shower with curb entry that could be difficult to step over for people with limited mobility (does not meet equitable use); small shower space with standing room only and no room for a caregiver to assist if needed (does not meet flexibility in use or size and space for approach and use); knob water/temperature control in shower that could be difficult to use for people with limited fine motor skills (does not meet flexibility in use or low physical effort); vanity with no space for a person in a seated position to pull under to access the sink, faucet, or electrical outlet (does not meet flexibility in use or size and space for approach and use); faucets with knobs that could be difficult to operate and adjust for people with limited fine motor skills (does not meet flexibility in use or low physical effort); knobs on cabinet doors and drawers that could be difficult to use for people with limited fine motor skills (does not meet flexibility in use or low physical effort).

The lower level of the home can only be accessed by going down a flight of stairs, indoors or outdoors, which is a barrier for people with limited mobility (does not meet

equitable use, flexibility in use, or low physical effort). There is also a step in the lower level master bedroom, another barrier for people with limited mobility as well as a safety hazard since the step is unexpected and often stumbled on by the subjects and visitors (does not meet equitable use or tolerance for error). The laundry room and home office are on the lower level, so the limited access to the lower level also creates a barrier to the washer, dryer, computer, printer, and files for people with limited mobility (does not meet equitable use).

The lower level bathrooms do not provide equitable use for people with wheelchairs, limited mobility, and limited fine motor skills because of elements such as: non-roll-under vanities (does not meet equitable use or size and space for approach and use), showers with curb entry (does not meet equitable use) and small footprints (does not meet size and space for approach and use), shower controls and sink faucets that are knobs and difficult for people with limited fine motor skills to use (does not meet flexibility in use or low physical effort); knobs on cabinet doors and drawers that are difficult for people with limited fine motor skills to use (does not meet flexibility in use or low physical effort); hot tub in the master bathroom that is difficult to get in and out of, especially for someone with limited mobility (does not meet equitable use, flexibility in use, or low physical effort).

Chapter 5: Conclusion and Recommendations for Further Research and Action

The subjects both expressed a love of their home and location, and they both stated that they want to remain in their home indefinitely. They want to preserve the open feeling and views of nature that their home currently offers. Based on the home analysis and the subjects' wishes, modifications could include a zero-step entry into the home, doorways wide enough for a person in a wheelchair to maneuver through, an accessible first floor bathroom, modified powder room, and durable, high quality fixtures, materials, and equipment throughout the home.

A universally designed kitchen and step-free access to the entire house is desired, but with the relatively short timeline of ALS and the \$10,000-\$13,000 budget, a full kitchen remodel and mechanical access features like elevators and wheelchair lifts are not feasible for this phase of the project. Since access to the lower level of the home will remain limited in this phase of the project, the modifications should focus on improving the first floor. The budget will allow for some small-scale functional and cosmetic improvements to the kitchen, which are important since the kitchen is a frequently used space and has a high return on investment at resale. Most of the budget will be utilized in a full remodel of the first floor full bathroom to make it accessible and modernized.

The subjects want to aesthetically and functionally improve their home without pricing it out of the market for their neighborhood. They both emphasized that they want the home to be efficient and accessible for people in wheelchairs and with limited strength as well as caregivers and people of all ages and abilities, but they do not want the home to look like a hospital design. They want their home to be beautiful, contemporary, warm,

welcoming, and truly functional so they can maintain their independence and autonomy as long as possible.

This aligns well with the principles and philosophy of universal design and will be the basis for their upcoming home modifications, as discussed in Chapter 6, Design 1. Chapter 7, Design 2 takes the research findings farther for an almost completely universally designed home modification. This larger scale endeavor could be taken on by homeowners with a bigger budget and a longer expected length of time to utilize the modifications, either to accommodate a long-term impairment or disability, living with young children, or simply to make life easier for everyone in the home. Universal design is often easier and less expensive to incorporate in the design phase, before a home or structure is built, but in this case, the subjects' home is in good condition and in a convenient and beautiful location, and the subjects love many elements of the home as is, so remodeling the home was the best decision for them.

Chapter 6: Application of Findings in Design 1

Design Concept and Background

Design 1, specific to the case study subjects' needs, aims to create an accessible and elegant update on a modest budget. Their ranch house with a past addition will get a stylish and functional update within a \$10,000-\$13,000 budget. One of the subjects is living with ALS, a degenerative disease with an average lifespan after diagnosis of two to five years. First floor accessibility, based on the subject's future mobility needs and universal design concepts, will create a gracious living environment so the subject can maintain as much autonomy as possible and so the spouse can easily care for him/her as his/her needs increase. Accessibility changes are designed to be aesthetically appealing and helpful to all people. Cosmetic and functional improvements will be made throughout the first floor and outside to increase the home's aesthetic appeal and market value and reflect the subjects' unique personalities. The subjects will ultimately have an elegant, inviting home that makes their lives easier without going over their budget.

Goals

The major goals of Design 1 are to create an accessible entrance into the home, remodel the first floor full bathroom to be accessible and beautiful, reclaim and update the first floor master bedroom, create a first floor laundry area, and modify and update elements in the kitchen, powder room, and first floor doors, furniture, finishes, and equipment to be more aesthetically pleasing and to make life easier for people with and without disabilities.

Solutions

To create an accessible entrance into the home, the concrete stoop, stairs, and walkway from the front (central) door of the house will be demolished and replaced with a

concrete ramp that gently slopes from the front door to the driveway, meeting universal design principles 1. equitable use, 2. flexibility in use, 6. low physical effort, and 7. size and space for approach and use (see Figures 1-3). Landscaping will be modified to be flush at the sides of the ramp, reducing chances of someone falling off the sides (universal design principle 5, tolerance for error) and blending the ramp into the landscape so it does not stand out as an accessibility element. This ramp blending also increases the subjects' safety; some burglars target homes that appear to have residents with disabilities because the burglars think they make easier targets to overpower.

On the west side of the house, existing wood stairs that lead down to the deck off the lower level will be replaced with concrete paver stairs, and existing railroad tie retaining walls (which are deteriorating) will be replaced with stacked concrete pavers. The decision to replace the stairs as opposed to installing a paved ramp was the subjects' preference. The slope of a straight ramp from the garage to the lower deck would be steeper than the ADAAG's 1:12 ratio, but since residences are not required to meet accessibility guidelines, a steeper ramp can be installed. In lieu of a paved ramp, some landscaping next to the stairs will be modified to allow space for a three-foot-wide grass slope, which is not ideal for wheelchairs, but it is the only way for a person who cannot use stairs to get to the deck. As another option, grass pavers could be installed to create a more stable ramp that blends with the landscape and maintains permeability. The addition of an exterior ramp will meet universal design principles 1. equitable use, 2. flexibility in use, 6. low physical effort, and 7. size and space for approach and use.

In the garage, the existing steps connecting the garage to the house present a barrier for a person with limited mobility, so a wood landing will be built over the concrete steps

that will be at the same grade as the interior flooring, with a fold-up metal ramp offering the option to roll down to the garage floor level and wood stairs offering the option to step down (see Figure 2). These modifications will meet universal design principles 1. equitable use and 2. flexibility in use.

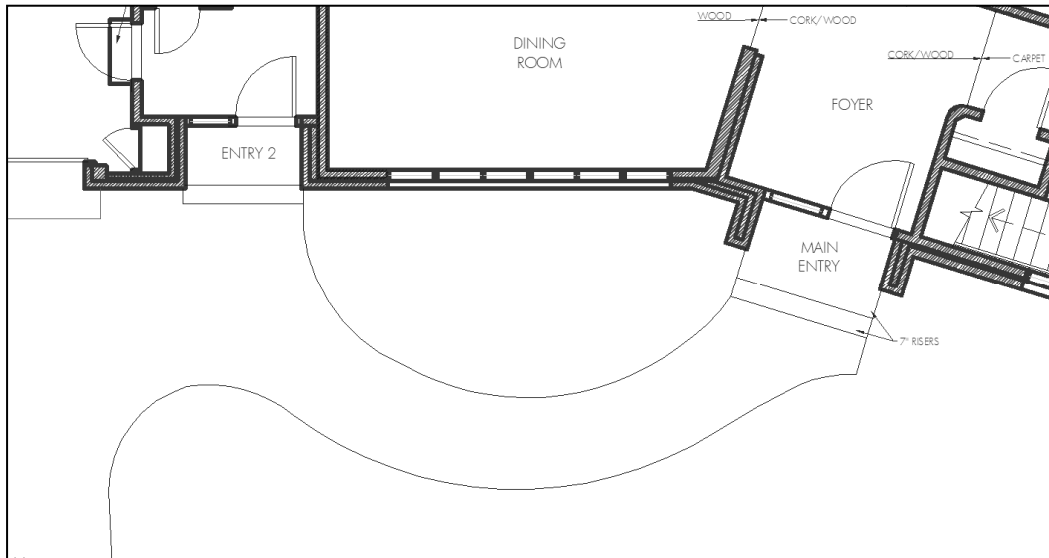

Figure 1. Existing plan view. This figure illustrates the existing plan view of the stoop, stairs, and walkway that connect the front door to the driveway.

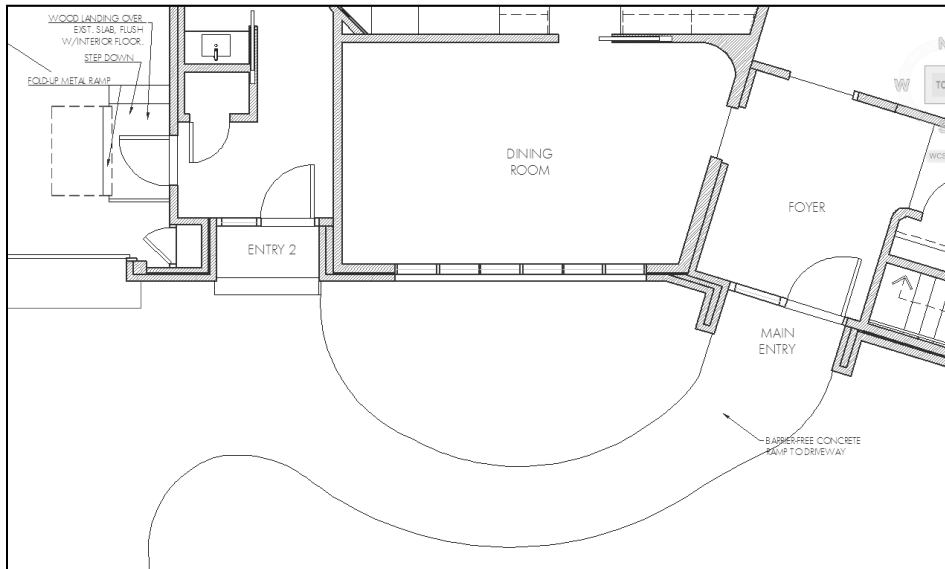

Figure 2. Remodel plan view. This figure illustrates the plan view of the ramp that will connect the front door to the driveway and the wood platform, steps, and fold-up ramp that will connect the garage to the house.

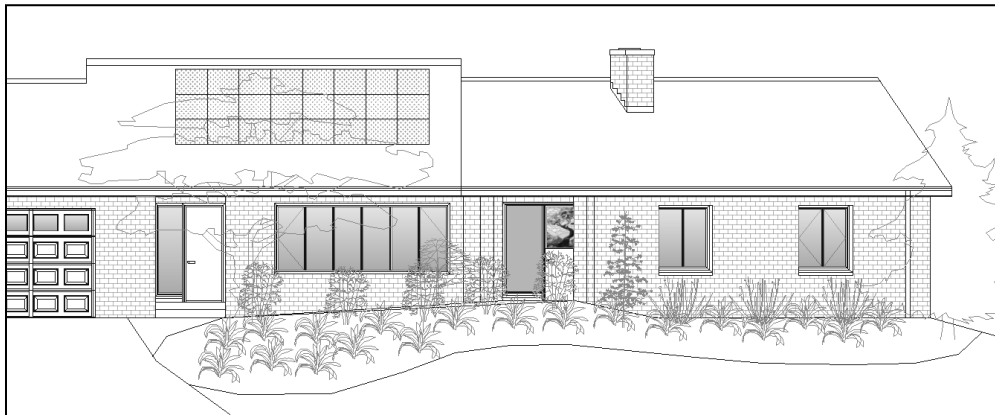

Figure 3. South exterior elevation. This figure illustrates the ramp (with new landscaping) that connects the front door to the driveway.

The existing first floor full bathroom has a dated vanity that offers storage but no space for a wheelchair to roll under the sink. In addition, the entry into the bathroom is narrow and dark, with the light switches almost four feet into the room. The shower is one of the biggest barriers for future accessibility because it is small, has a knob water/temperature control, and has a curb to enter and exit. This means a person must be able to stand on his or her own to use the shower, and must have good fine motor skills to operate and adjust the water pressure and temperature. The existing toilet is a standard toilet. The remodeled bathroom will include a 36" wide door, wider entry area with light switches right by the door, a roll-under vanity with 34-1/2" counter height, improved, adjustable lighting that includes tall vanity sconces for ample light for people in seated and standing heights, sleek grab bars, a roll-in shower with space for a caregiver and a person in a wheelchair or on a bench, easy to operate lever handle water controls, conveniently located adjustable height hand shower that is set apart from the main showerhead, and a universal height toilet with bidet functions, meeting universal design principles 1. equitable use, 2. flexibility in use, 5. tolerance for error, 6. low physical effort, and 7. size and space for approach and use (see Figures 4-7).

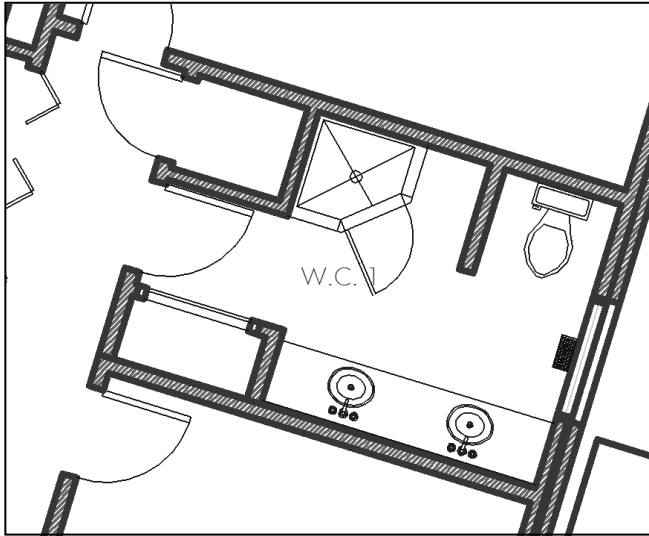

Figure 4. Existing first floor full bathroom plan view. This figure illustrates the plan view of the existing first floor full bathroom.

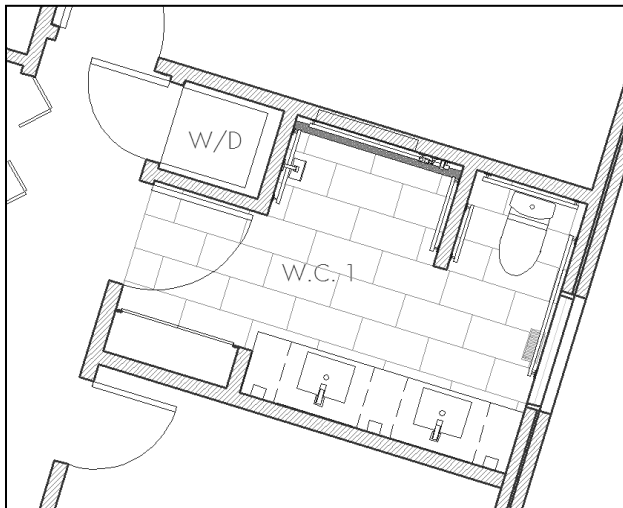

Figure 5. Remodel first floor full bathroom plan view. This figure illustrates the plan view of the post-remodel first floor full bathroom and the plan view of the post-remodel first floor laundry area (labeled W/D for the stacked washer/dryer).

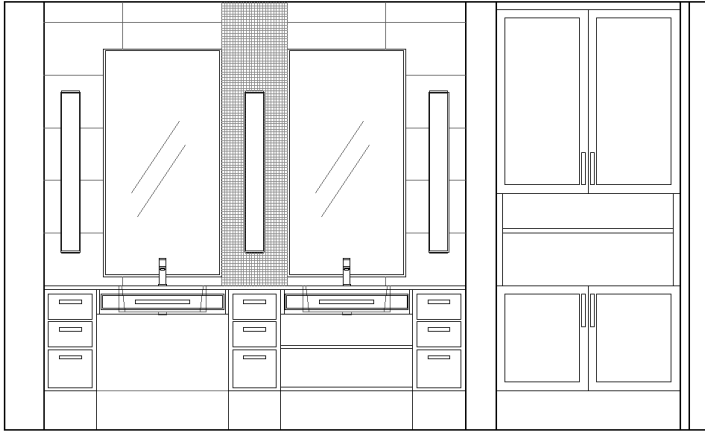

Figure 6. Remodel first floor full bathroom north elevation. This figure illustrates the roll-under vanity, lower counter height, and tall mirrors and sconces of the post-remodel first floor full bathroom.

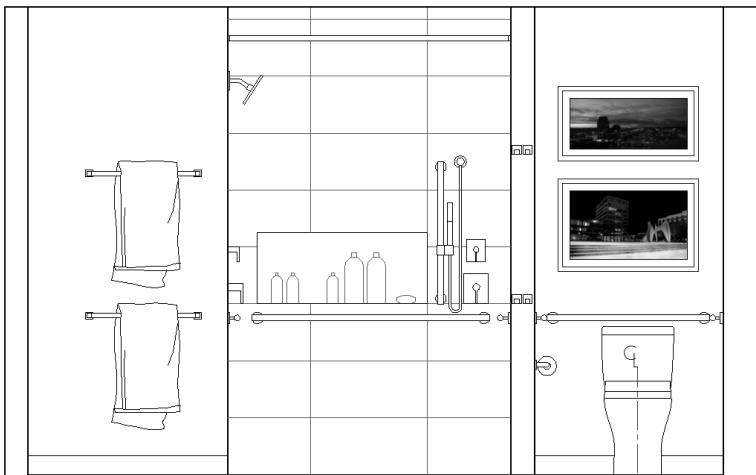

Figure 7. Remodel first floor full bathroom south elevation. This figure illustrates the roll-in shower, grab bars, and lever-handle water and temperature controls, hand shower, universal height toilet, and washlet seat of the post-remodel first floor full bathroom.

Because the laundry room is on the lower level and the scope of this project will not include an accessible way to go between levels of the home, a laundry area needs to be added on the first floor. The existing linen closet between the first floor full bathroom and the future master bedroom is an appropriate size and a great location for a stacked front loading washer and dryer. A washer and dryer were chosen based on easy-t-o-reach controls so they can easily be operated by a person with limited reach, height, or who is in a seated position. The subjects can choose to keep the existing door on the laundry closet or replace it with a fixed shower rod and modern shower curtain or drapery panel to avoid any door swing interference. Creating a convenient and accessible laundry area that also functions well for people with no limitations meets universal design principles 1. equitable use, 2. flexibility in use, 6. low physical effort, and 7. size and space for approach and use (see Figure 5).

In the kitchen, since the budget will not cover new cabinetry or layout, smaller modifications will be made. The small knobs on the cabinet doors and drawers will be replaced with sleek handles which will provide a more modern look and, more importantly, be easier to operate with limited fine motor skills and strength (universal design principles 1. equitable use, 2. flexibility in use, and 6. low physical effort). In addition, faucets will be replaced with sensor faucets that do not require reaching or operating the faucet handle (universal design principles 1. equitable use, 2. flexibility in use, and 6. low physical effort), an additional microwave will be added to a countertop since the existing microwave is installed above a wall oven and is out of reach for people who are shorter, have limited reach, or are in a seated position (universal design principles 1. equitable use, 2. flexibility in use, and 6. low physical effort), sleek glass tile will be installed on the backsplash, and dated

brass lighting fixtures will be replaced with more contemporary pendants to update the look of the kitchen and be more in line with the subjects' personal design aesthetic (see Figure 8).

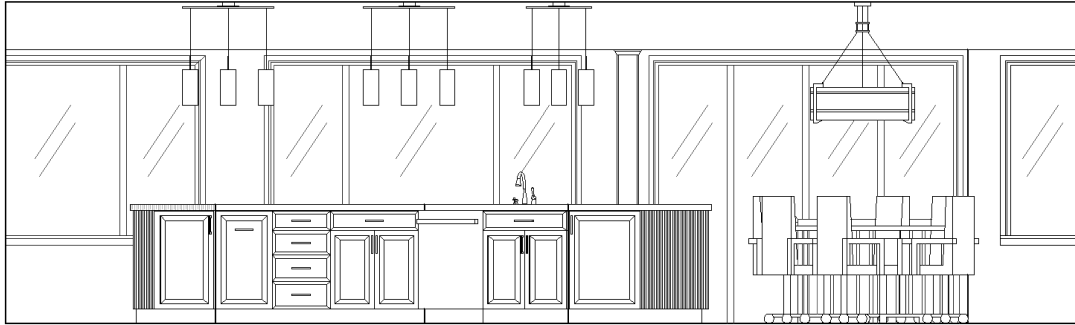

Figure 8. Remodel kitchen south elevation. This figure illustrates the updated handles, faucet, and pendant lighting in the post-remodel kitchen.

In the cramped powder room, while there is not enough in the budget to cover a major renovation to update and enlarge the space, it is still possible to open up the entry into the powder room by installing a pocket door in a wider 34" doorway, a shallower 18" deep vanity with large 9" high x 6" deep toekick, easy to operate bar handles on the cabinet doors, and universal height toilet (universal design principles 2. flexibility in use, 6. low physical effort, and 7. size and space for approach and use). In addition, the powder room, which has not been updated since the house was built, has dated and deteriorating 1970s wallpaper, floor tile, faucet, vanity, lighting, and avocado color toilet and sink. The subjects expressed a desire to make the powder room a "wow" room since so many of their guests see it, so this space will get a major cosmetic makeover with contemporary 12" x 24" floor tile, sophisticated neutral paint, statement art, shaker-style vanity, quartz counter, under-counter sink, floating wood display shelves, and modern faucet and lighting (see Figures 9-10).

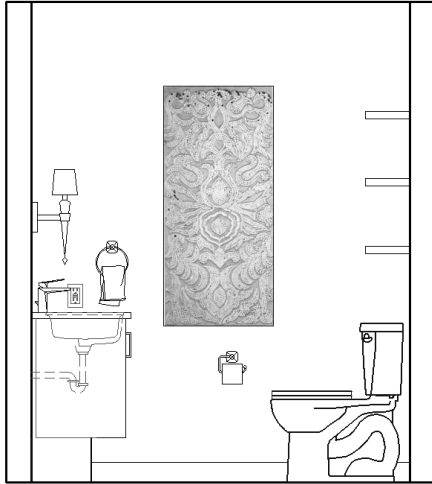

Figure 9. Remodel powder room east elevation. This figure illustrates the updated art, sconces, vanity, faucet, sink, counter, toilet, shelves, and accessories in the post-remodel powder room.

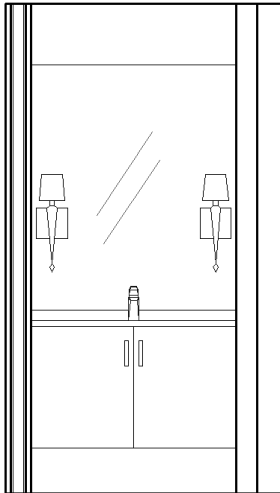

Figure 10. Remodel powder room north elevation. This figure illustrates the updated sconces, vanity, faucet, and counter in the post-remodel powder room.

In the rest of the first floor, the future master bedroom door and the full bathroom door will be replaced with 36" wide doors. The rest of the doors, used less often but slightly narrower than preferred, can either be replaced with wider doors, have the doors removed altogether where appropriate, or have swing-clear hinges installed to maximize the clearance. Most of the existing furniture will remain in the home, but a custom side table will be made that can adjust in height and swivel to comfortably accommodate Subject 1's communication tools, feeding tube stand, reading materials, and snacks and beverages for anyone. The furniture will be arranged to allow easy wheelchair maneuvering, natural spaces for a person in a wheelchair to join others who are seated in lounge furniture or watching television, and to maximize conversation zones and easy of hearing so the subjects can communicate and be heard clearly.

In the future master bedroom, ample space will be reserved on either side of the bed and in front of the closets and dressers to allow the subjects to easily maneuver around the room. Any existing carpeting and rugs will be removed as they are tripping hazards for people with balance difficulties and sight difficulties and a constant hindrance for people in wheelchairs. Wood flooring stained to match other existing wood flooring will replace wall to wall carpeting, and the noise and aesthetic will be softened by the installation of Flor carpet tiles, which do not slip on the floor and have a very low pile and thus present a minimal tripping hazard and no wheelchair hindrance. In addition, if a tile is damaged by a wheelchair wheel or for any reason, the tile can be removed for cleaning or easily replaced (see Figures 11-12).

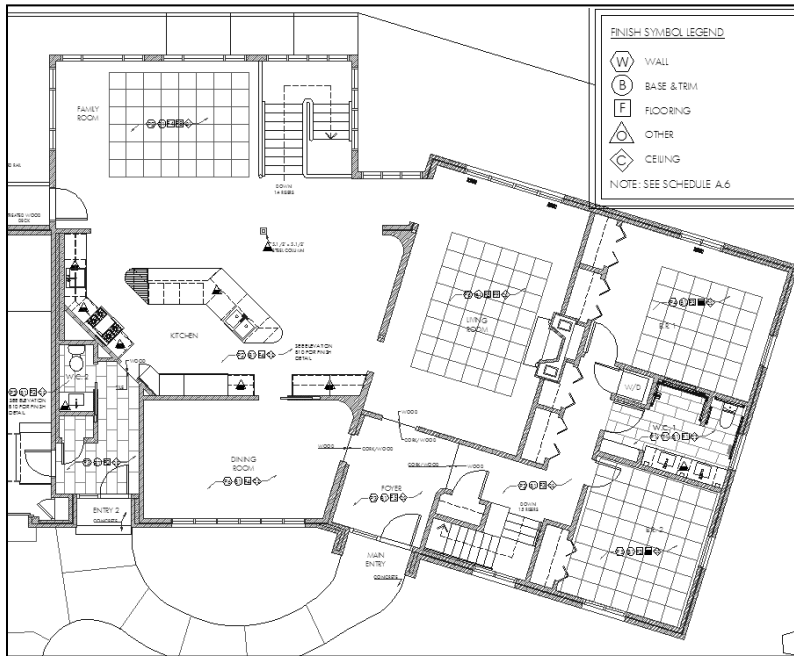

Figure 11. Remodel finish floor plan. This figure illustrates the finishes for the first floor in the remodeled design. The square patterns indicate Flor tile rugs. The rectangle patterns indicate 12"x24" floor tiles. The remaining floors are stained maple, and the foyer floor will remain unchanged, with its unique maple and cork pattern.

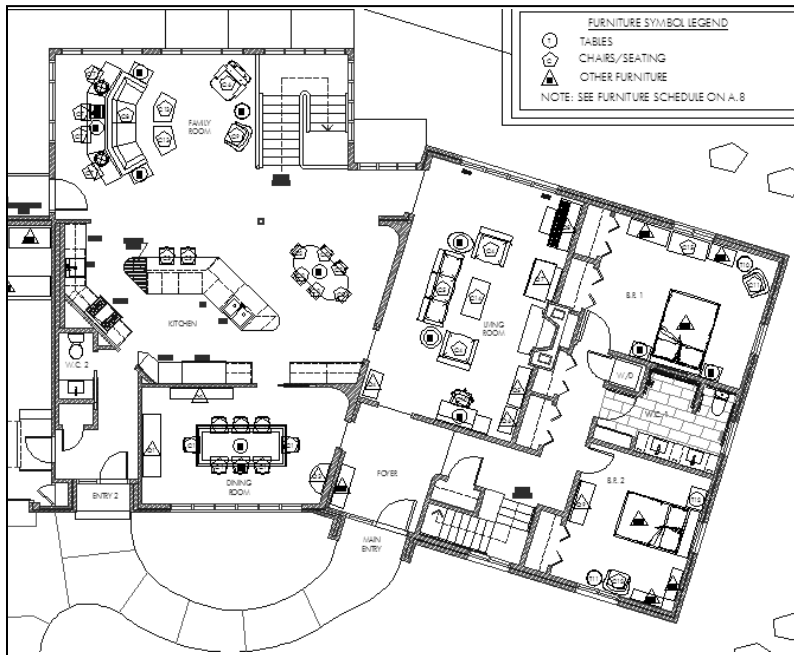

Figure 12. Remodel furniture floor plan. This figure illustrates the furniture and space planning for the first floor in the remodeled design.

Space was maintained in seating arrangements so a person in a wheelchair can easily join a conversation, and some custom side-tables will make it easier for the subject with ALS to utilize his/her communication tools, eat via the feeding tube, read, and more. The tables will also be helpful to all people because of the adjustable height and swivel mechanism.

Chapter 7: Application of Findings in Design 2

Design Concept and Background

This design will use the same home and will incorporate more of the subjects' wishes for their home that may not be possible within their budget. The design aims to create a true universally designed home, appropriate for anyone, especially someone with a long-term need for a universally accessible and safe home.

Goals

The major goals of Design 2 are to create at least three accessible, convenient, and inclusive entrances into the home, universal design bathrooms on all floors that satisfy or get close to meeting the ADAAG, new first floor laundry area, remodeled kitchen with adapted existing cabinetry in new arrangement, easily accessible landscaping and outdoor areas, an updated first floor master bedroom, and modified and updated doors, furniture, finishes, and equipment that are more aesthetically pleasing and that make life easier for people with and without disabilities.

Solutions

As in Design 1, the concrete stoop, stairs, and walkway from the front (central) door of the house will be demolished and replaced with a concrete ramp that gently slopes from the front door to the driveway, meeting universal design principles 1. equitable use, 2. flexibility in use, 6. low physical effort, and 7. size and space for approach and use (see Figures 1-3). Landscaping will be modified to be flush at the sides of the ramp, reducing chances of someone falling off the sides (meeting universal design principle 5, tolerance for error) and blending the ramp into the landscape so it does not stand out as an accessibility element. Equitable accessibility to the house will be increased in Design 2: the exterior paver

stairs on the west side of the house will have an adjacent paver ramp, and stair and ramp landings will align to allow a person using the ramp to move to the stair landings and roll under cantilevered areas of the retaining wall landscaping beds, meeting universal design principles 1. equitable use, 2. flexibility in use, 6. low physical effort, and 7. size and space for approach and use (see Figure 13).

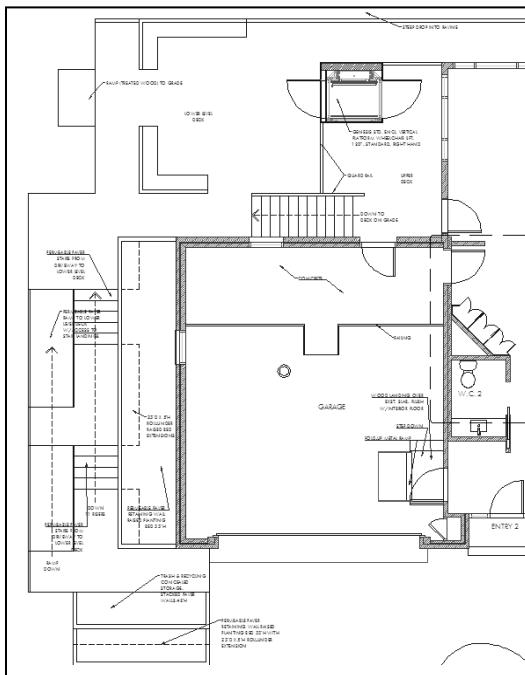

Figure 13. First floor plan view: exterior ramp, stairs, retaining wall planters, first floor deck with enclosed wheelchair lift, and door between garage and kitchen. This figure illustrates the design elements that will allow people with limited mobility or strength to engage in gardening and access and move between the lower deck, front of the house, and interior.

A first floor deck will be built on the west side of the existing great room, and a wheelchair lift, enclosed in transparent plexiglass, will be installed within the first floor deck to allow a person with limited mobility to easily move between the house and deck areas,

meeting universal design principles 1. equitable use, 2. flexibility in use, 6. low physical effort, and 7. size and space for approach and use (see Figure 13). Also, a new door into the garage will be added where the existing wall ovens are located. This northern section of the garage has an existing concrete platform that is flush with the interior floor, and the existing concrete ramp from the raised platform to the on-grade garage slab will be widened. This new door connecting the garage and kitchen will provide an easy and convenient way for a person with limited mobility to move between the kitchen and garage, meeting universal design principles 1. equitable use, 2. flexibility in use, 6. low physical effort, and 7. size and space for approach and use (see Figure 13). In total, there will be 4 equitably accessible entrances into the house.

Inside the home, the biggest change in Design 2 will be the installation of a residential elevator and a platform wheelchair lift. These additions will provide equitable access to the entire house for people with and without impairments and disabilities, meeting universal design principles 1. equitable use, 2. flexibility in use, 6. low physical effort, and 7. size and space for approach and use. The elevator will be installed where the existing coat closet and part of the south staircase is currently located on the first floor, at the main entrance to the house. On the lower level, the elevator will necessitate removing an existing storage closet, but there will be space to the west to add a smaller storage closet, and the lower level living room will gain some additional depth with the modifications. The machine room will be adjacent to the elevator on its east side, with the machine room door accessible inside the laundry room. The elevator doors will match the home's other interior doors, and the elevator's interior will be finished with wood flooring, wainscoting to protect the lower

walls from any bumps, paint, trim, and sleek grab bars so it will have a polished, residential look and will not look institutional (See Figures 14-17).

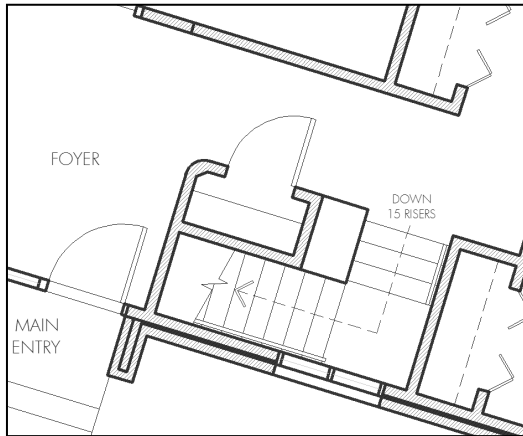

Figure 14. First floor plan view of existing south staircase and adjacent coat closet and foyer.

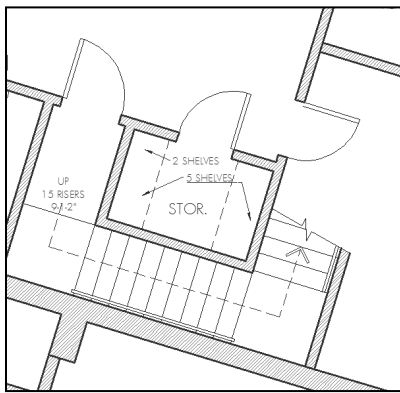

Figure 15. Lower level plan view of existing south staircase and adjacent laundry room.

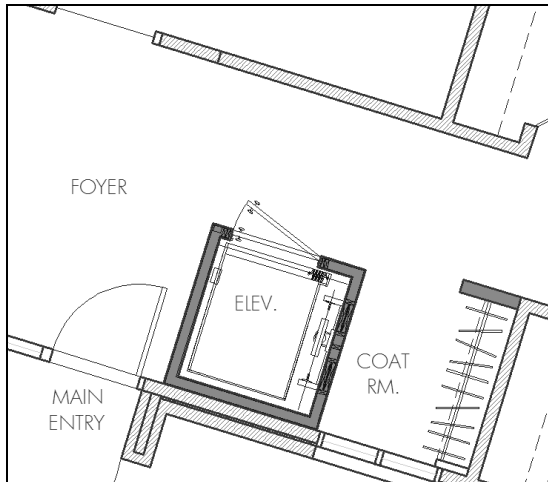

Figure 16. Post-renovation first floor plan view of elevator and adjacent coat room and foyer.

This figure illustrates the installation of the residential elevator and relocation of the coat closet, in place of the former staircase.

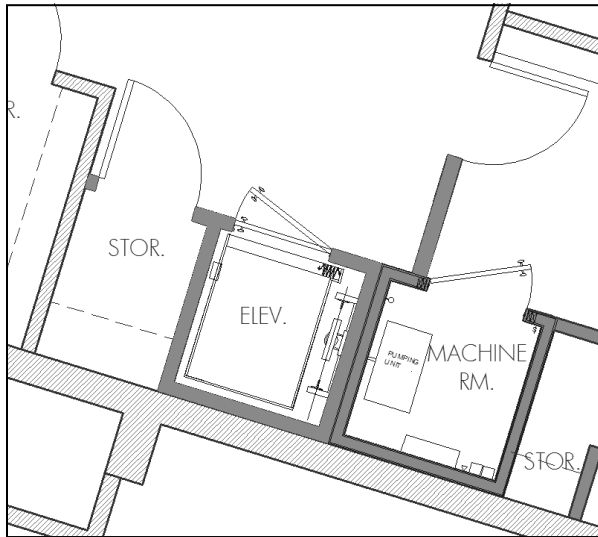

Figure 17. Post-renovation lower level plan view of elevator and adjacent machine room, storage room, laundry/craft room, and lower level living room. This figure illustrates the installation of the residential elevator and machine room, the removal of an existing storage closet, and addition of a new storage closet, in place of the former staircase.

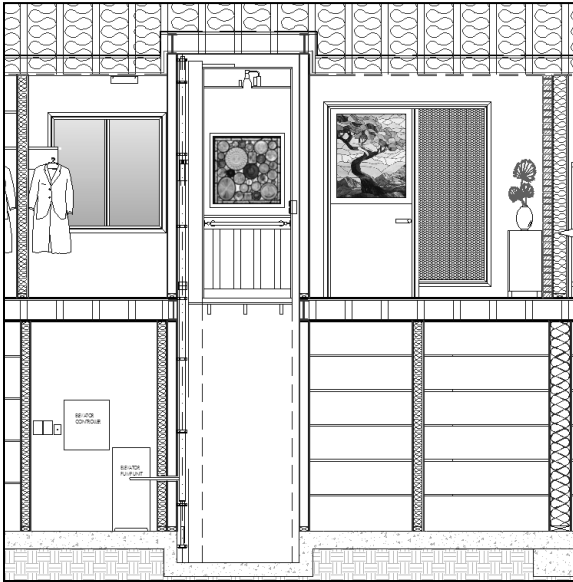

Figure 18. Post-renovation section cut of elevator and adjacent machine room, storage rooms, and coat room, and foyer. This figure illustrates the installation of the residential elevator and machine room.

At the home's north staircase, an elevator is not desired because it would block daylight and views of the trees and ravine outside. A platform wheelchair lift will be installed at the staircase to provide equitable access to the lower level at this side of the house, which is important because the master bedroom and bathroom are adjacent to this staircase on the lower level. The platform wheelchair lift folds into a compact position when it is not in use, preserving ample space on the stairs for when the lift is not needed (see Figures 19-21).

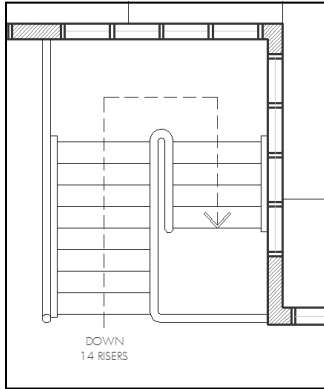

Figure 19. First floor plan view of existing north open staircase.

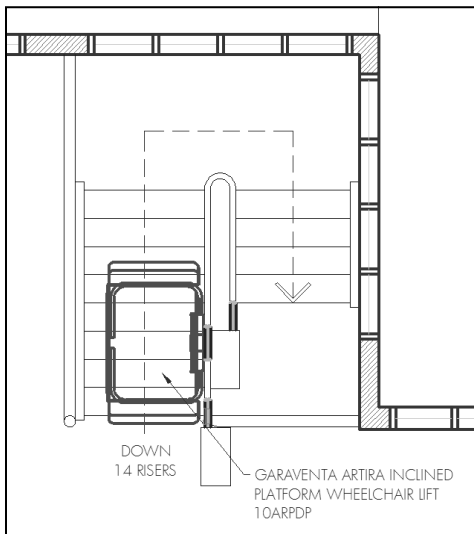

Figure 20. Post-renovation first floor plan view of north open staircase with platform wheelchair lift installation. This figure illustrates the staircase with the platform wheelchair lift in the open position, ready for a person to walk or wheel on or off of the platform.

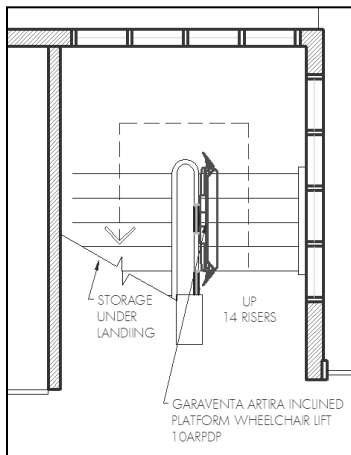

Figure 21. Post-renovation lower level plan view of north open staircase with platform wheelchair lift installation. This figure illustrates the staircase with the platform wheelchair lift in the closed position, leaving ample space for people to walk up and down the stairs.

With the bigger scope of this universal design and thanks to the multi-floor access provided by the elevator and platform wheelchair lift, all four bathrooms in the house will be remodeled with elements including roll-in showers, vanities with roll-under sinks or at least an enlarged toekick, universal height toilets, updated lighting on dimmers, handles and fixtures that are easy to operate, and an updated style. The first floor full bathroom will receive the same remodel as in Design 1 (see Figures 5-7), with the existing vanity, sinks, faucets, lighting, shower, toilet, and storage cabinets getting replaced with updated, functional versions. The narrow, dark entry into the bathroom, with distant light switches will be modified with a 36" wide door and wider entry area with paddle light switches right by the door. The shower, one of the biggest barriers for future accessibility because of its small size, knob water/temperature control, and curb, will be replaced with a roll-in shower with grab bars, easy to operate lever handle water controls, conveniently located hand shower with adjustable height that is set apart from the main showerhead, and space for a caregiver and a

person in a wheelchair or on a bench. The existing waterhog toilet will be replaced with a universal height toilet with bidet-function washlet seat. The dated vanity with no space for a wheelchair or seat to move under will be replaced with a roll-under vanity with 34-1/2” counter height. The dated, hot, incandescent vanity lighting will be replaced with modern tall bar sconces on dimmers for ample light for people in seated and standing heights. The modified first floor full bathroom will meet universal design principles 1. equitable use, 2. flexibility in use, 5. tolerance for error, 6. low physical effort, and 7. size and space for approach and use (see Figures 4-7).

The existing laundry room is on the lower level, but an additional washer and dryer will be installed in the existing linen closet near the first floor full bathroom. This will provide a more convenient location for laundry of people who use the first floor bedrooms and bathrooms and for kitchen and dining room linens. The existing linen closet was chosen because of its convenient location near the bedrooms and full bathroom and because it is an appropriate size to fit the stacked washer and dryer. The subjects can choose to keep the existing door on the laundry closet or replace it with a fixed shower rod and shower curtain or drapery panel to avoid any door swing interference. Creating a convenient and accessible laundry area that also functions well for people with no limitations meets universal design principles 1. equitable use, 2. flexibility in use, 6. low physical effort, and 7. size and space for approach and use (see Figure 5).

The first floor powder room will receive a more extensive remodel than in Design 1, with walls getting pushed out to make the space wider and deeper. In addition, the doorway will be enlarged to 36” wide with a pocket door, and grab bars, high-tech Neorest bidet toilet, and custom 18” deep roll-under vanity being added, meeting universal design principles 1.

equitable use, 2. flexibility in use, 6. low physical effort, and 7. size and space for approach and use. As in Design 1, the powder room will get a major cosmetic facelift to transform from a dated look to a sleek, contemporary look thanks to 12" x 24" contemporary floor tile, sophisticated neutral paint, statement art, shaker-style vanity, quartz counter, under-counter sink, floating wood display shelves, and modern faucet and lighting (see Figures 22-24).

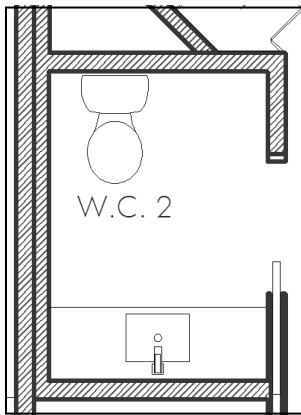

Figure 22. First floor powder room plan view. This figure illustrates the enlarged space and wider door of the powder room.

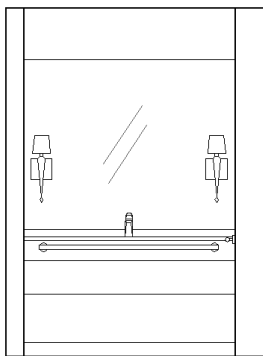

Figure 23. First floor powder room south elevation. This figure illustrates the custom vanity in the powder room.

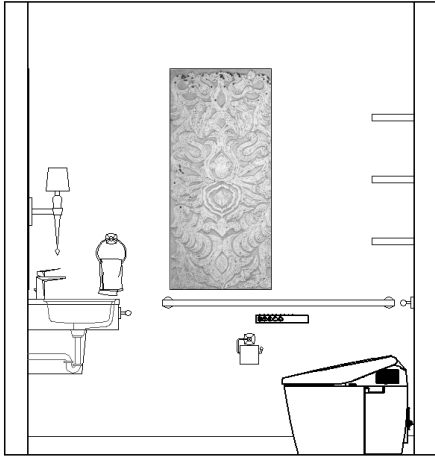

Figure 24. First floor powder room west elevation. This figure illustrates the grab bars, bidet toilet, and custom vanity.

Because the elevator and stair lift will allow equitable access between the first floor and lower level of the home, the subjects will have the option of remaining in the lower level master bedroom. Therefore, Design 2 will include a remodel of the existing master bathroom, also on the lower level of the home. To make it easier to get in and out of the shower and the bathtub, the two will switch places in the modified bathroom (see Figures 25-26).

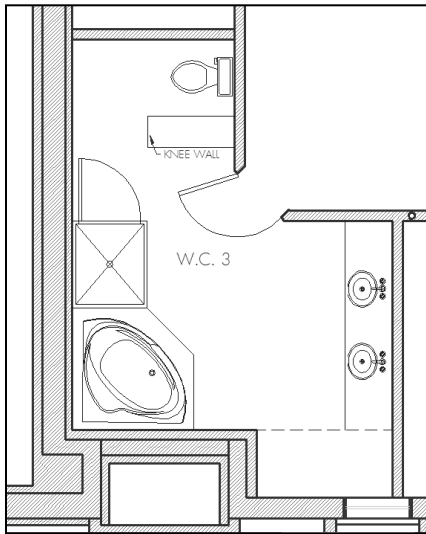

Figure 25. Existing master bathroom plan view.

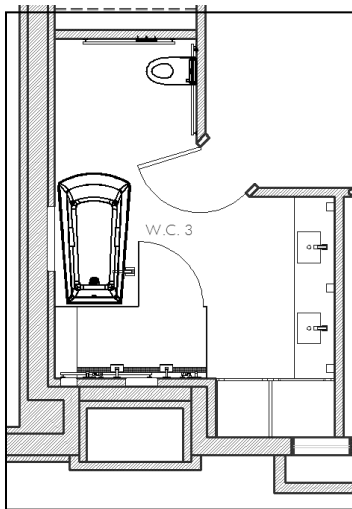

Figure 26. Post-renovation master bathroom plan view.

The existing small shower with its awkward, curb entry and knob controls will be replaced by a large, roll-in shower with two showerheads, two adjustable height hand showers, and built-in bench. The existing large jet tub is difficult to get in and out of even for a person with no impairments, so it will be replaced with a sleeker jet tub that includes grab bars, and the new location and orientation of the tub will also make it easier to get in and out.

A freestanding lever handle tub faucet with attached hand shower will be easy for people of all abilities to reach and operate. The existing vanity will be replaced with a 34-1/2" high roll-under vanity, and the existing lighting will be replaced with modern bar sconces at the vanity, recessed lighting for increased visibility throughout the bathroom, and an accent pendant over the new jet tub. The existing knee wall will be removed to open the space for easier maneuvering in a wheelchair, and the existing toilet will be replaced with a high-tech Neorest bidet toilet. The 32" wide door into the bathroom will be replaced with a 36" wide door. These modifications will create a bathroom that meets universal design principles 1. equitable use, 2. flexibility in use, 5. tolerance for error, 6. low physical effort, and 7. size and space for approach and use (see Figures 27-29).

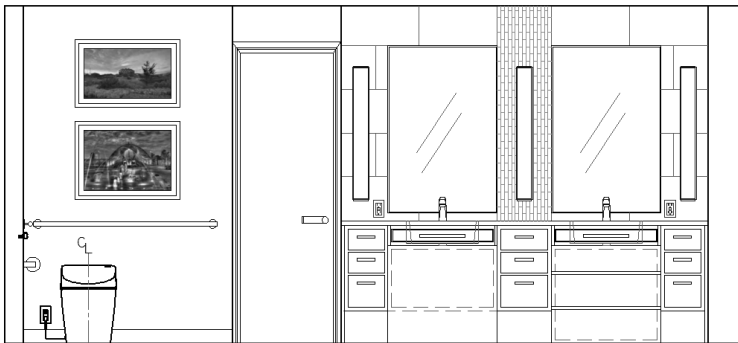

Figure 27. Post-renovation master bathroom west elevation. This figure illustrates the bidet toilet, grab bars, wider door, roll-under vanity, and bar sconces that will be installed in the master bathroom.

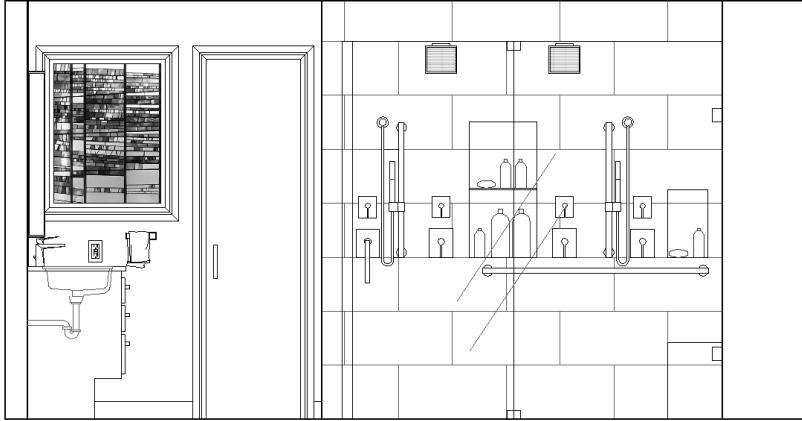

Figure 28. Post-renovation master bathroom north elevation. This figure illustrates the new shower with two shower heads, two adjustable height hand showers, grab bar, and built in bench.

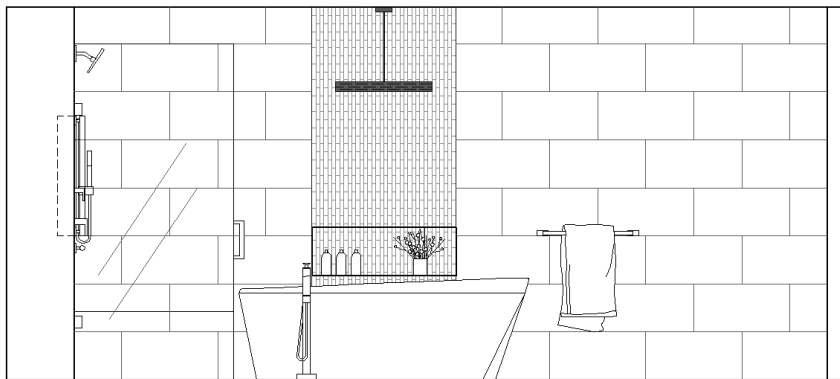

Figure 29. Post-renovation master bathroom east elevation. This figure illustrates the new shower, jet tub, and freestanding tub faucet.

The lower level guest bathroom will also be remodeled in Design 2, replacing dated and deteriorating fixtures and finishes with new tile, vanity, sink, faucet, counter, lighting, universal height toilet, and roll-in shower with grab bars, lever handle water controls, and adjustable height hand shower. The door into the bathroom will be widened to 36". While the

modest size bathroom does not have space for a 60” diameter turn space as the ADAAG recommend, the vanity includes a large 9” x 6” toekick to allow a closer sink approach, and the space plan provides open pathways between the door, toilet, sink, and shower. The room will feel more spacious with the frameless glass shower walls, increased lighting on dimmers, and soothing neutral colors. These modifications will help the renovated lower level guest bathroom meet universal design principles 2. flexibility in use, 5. tolerance for error, and 6. low physical effort (see Figures 30-32).

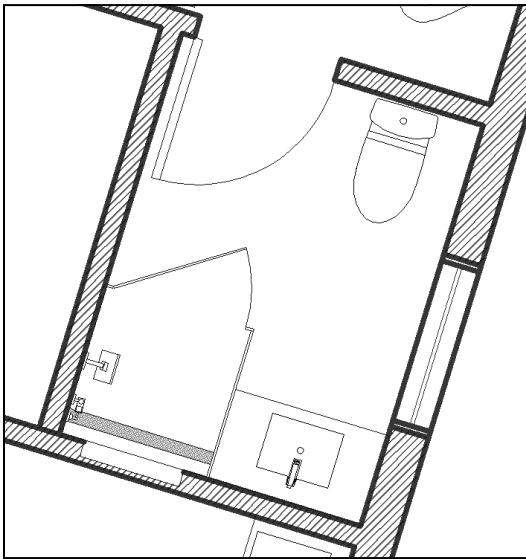

Figure 30. Post-renovation lower level guest bathroom plan view.

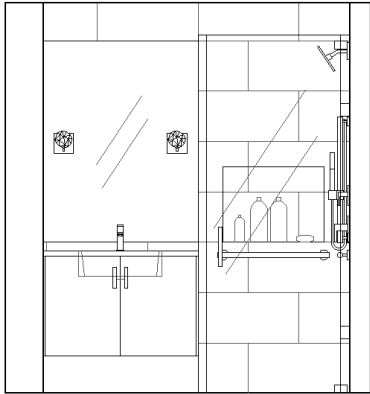

Figure 31. Post-renovation lower level guest bathroom north elevation. This figure illustrates the new shower, vanity, sconces, faucet, and tile in the renovated guest bathroom.

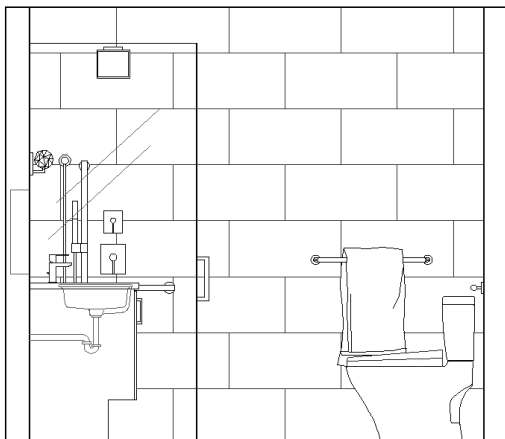

Figure 32. Post-renovation lower level guest bathroom east elevation. This figure illustrates the new shower, shower fixtures, universal height toilet, vanity, sconces, faucet, and tile in the renovated guest bathroom.

In Design 2, the kitchen will get a bigger renovation to increase accessibility, function, and style. Because of the new door being added between the kitchen and garage, the existing wall of cabinetry will be removed. Mudroom storage cabinets, with door style and finish to match the existing kitchen cabinetry, will be installed near the new door to provide

storage for coats and shoes. The existing island cabinets and fixtures will also be removed, and some of the removed cabinets will be placed back in the kitchen in different locations (see Figure 32).

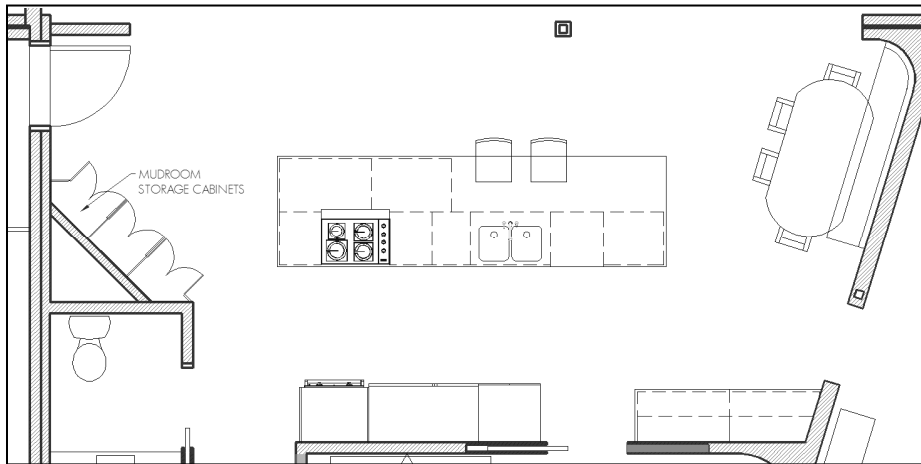

Figure 33. Post-renovation kitchen plan view. This figure illustrates the new space plan of the kitchen, including the door to the garage, mudroom storage cabinets, built-in banquette, and wider access to the corridor near the bathroom.

Counter heights in the kitchen will be lowered to 34-1/2" A.F.F. All the base cabinets in the kitchen will be modified to have a bigger 9" x 6" toe kick and shorter doors and drawer fronts in the matching style and finish of the existing cabinets. The existing pantry will be moved to the opposite side of the refrigerator, and the existing oven cabinet will be placed where the existing pantry is, with two new wall ovens installed. The ovens will be separate single ovens so that the lower oven's controls are reachable for people who are shorter, have limited reach, or are in a seated position. The remaining wall cabinets will be removed and reinstalled on a wall cabinet lift, which will shift the cabinets down to counter height with the

push of a button, providing access to people who are shorter, have limited reach, or are in a seated position (see Figure 33).

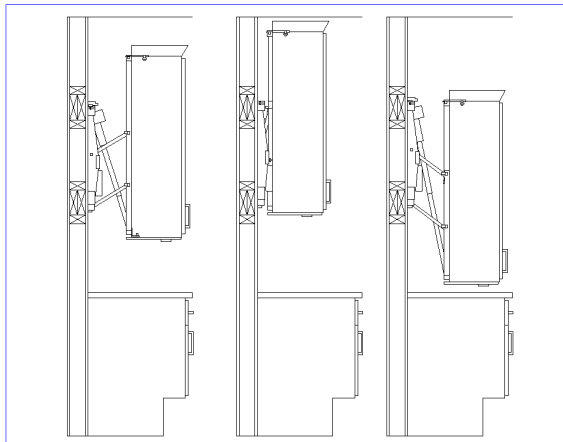

Figure 34. Kitchen wall cabinet lift section cut. This figure illustrates the wall cabinet lift that will be installed in the universal design kitchen.

In the new island, a new shallow-depth sink will be installed with space to roll under. Similarly, an induction range will be installed with space to roll under. The lack of heat on the induction range (heat only transfers to the pots and foods being cooked) will be an added safety feature for people with cognitive impairments, sight impairments, or young children. On the other side of the island, there will be a wide space open under the counter that is available to sit on a barstool or roll under in a wheelchair or scooter. The existing small knobs on the cabinet doors and drawers will be replaced with sleek handles which will provide a more modern look and, more importantly, be easier to operate with limited fine motor skills and strength (universal design principles 1. equitable use, 2. flexibility in use, and 6. low physical effort). In addition, the sink faucet will be replaced with a sensor faucet that does not require reaching or operating the faucet handle (universal design principles 1.

equitable use, 2. flexibility in use, and 6. low physical effort). A microwave will be installed on a hoist lift in one of the base cabinets, and a stand mixer will be installed on another hoist lift in a different base cabinet, providing easy, reachable access to these appliances (universal design principles 1. equitable use, 2. flexibility in use, 6. low physical effort, and 7. size and space for approach and use). In the kitchen's dining area, a banquette will be installed along the curved wall, upholstered in a commercial-grade stain resistant fabric, and the existing table and chairs will pull up to the banquette. Sleek glass tile will be installed on the backsplash, and dated brass lighting fixtures will be replaced with more contemporary pendants to update the look of the kitchen and be more in line with the subjects' personal design aesthetic (see Figures 34-36). The kitchen's modifications will help it meet universal design principles 1. equitable use, 2. flexibility in use, 5. tolerance for error, 6. low physical effort, and 7. size and space for approach and use.

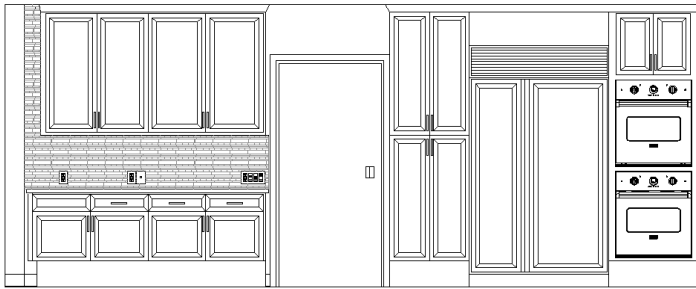

Figure 35. Post-renovation kitchen north elevation. This figure illustrates the modified cabinetry, reversed pocket door, new wall ovens, and relocated pantry.

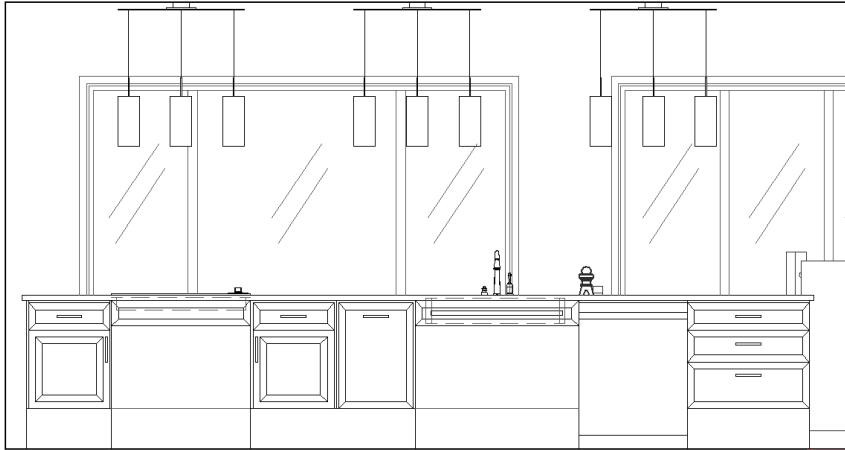

Figure 36. Post-renovation kitchen south elevation. This figure illustrates the modified and rearranged cabinetry, roll-under sink and induction range, sensor faucet, and updated pendant lighting over the kitchen island.

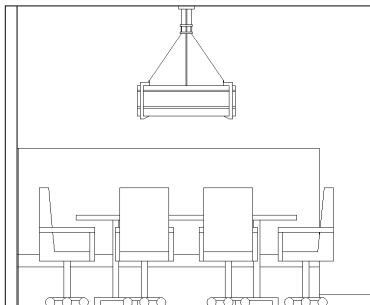

Figure 37. Post-renovation kitchen west elevation. This figure illustrates the new upholstered banquette and updated pendant in the kitchen dining area.

In the rest of the home, all doors will be replaced with 36" wide doors. Most of the existing furniture will remain in the home, but a few new pieces will be added for function, comfort, and aesthetics. Custom side tables with adjustable height and swivel mechanism will make it easier for the subject with ALS to communicate on her tablet and via writing, eat from her feeding tube, read, and more (see Figures 37-40). The furniture will be arranged to

allow easy wheelchair maneuvering, natural spaces for a person in a wheelchair to join others who are seated in lounge furniture or watching television, and to maximize conversation zones and ease of hearing so the subjects can communicate and be heard clearly. In the master bedroom, ample space will be reserved on either side of the bed with help from an extension of the wall behind the headboard (see Figure 39).

Any existing carpeting and rugs will be removed as they are tripping hazards for people with balance difficulties and sight difficulties and a constant hindrance for people in wheelchairs. Wood flooring stained to match other existing wood flooring will replace wall to wall carpeting on the first floor, and the noise and aesthetic will be softened by the installation of Flor carpet tiles, which do not slip on the floor and have a very low pile and thus present a minimal tripping hazard and no wheelchair hindrance. In addition, if a tile is damaged by a wheelchair wheel or for any reason, the tile can be removed for cleaning or easily replaced. The lower level will have wood-look porcelain tile installed, with Flor carpet tiles and acoustic ceiling panels helping to absorb sound.

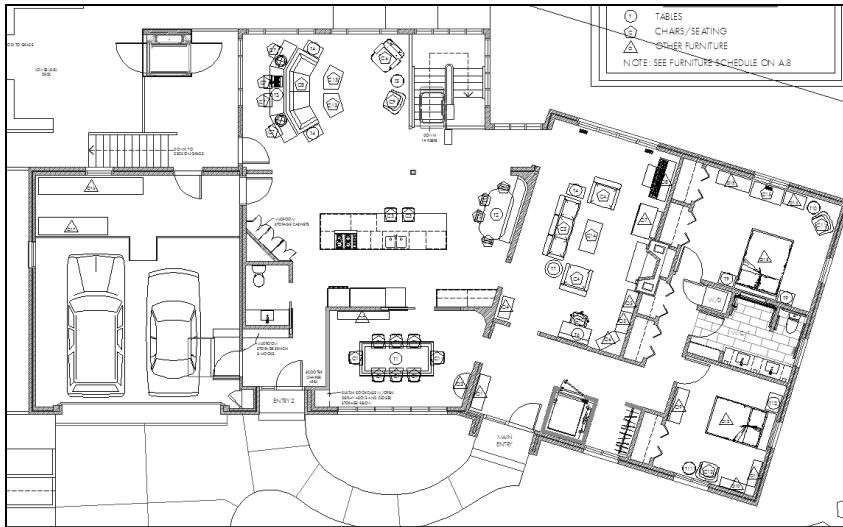

Figure 38. Post-renovation first floor furniture floor plan.

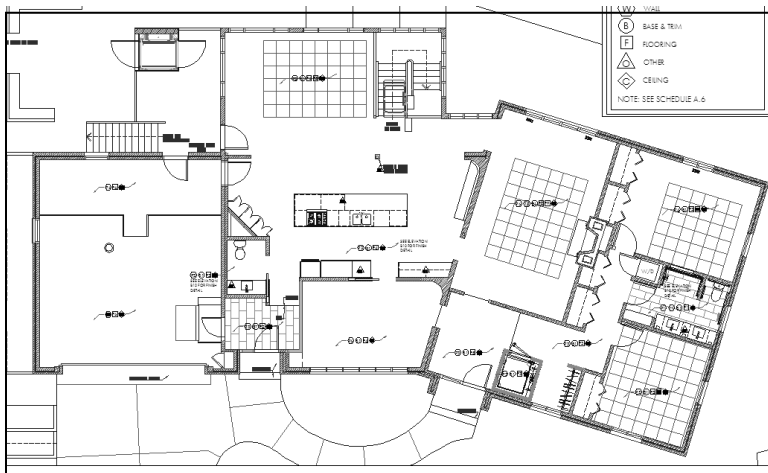

Figure 39. Post-renovation first floor finish floor plan.

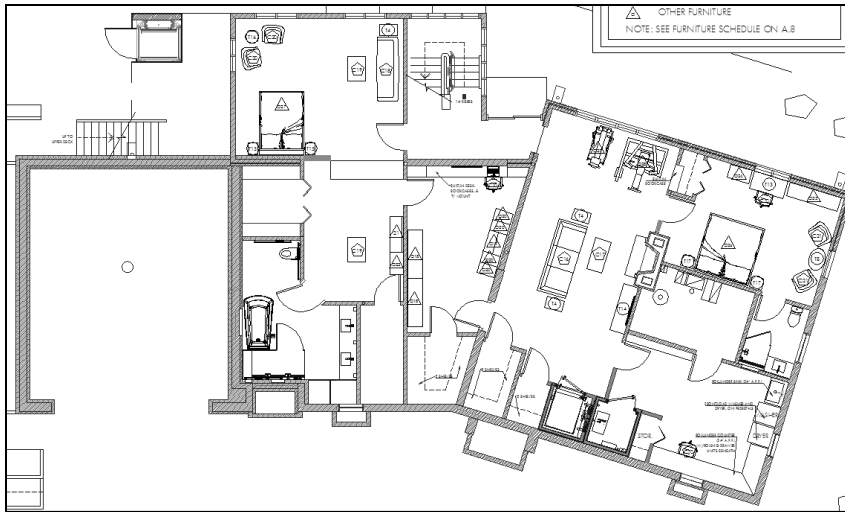

Figure 40. Post-renovation lower level furniture floor plan.

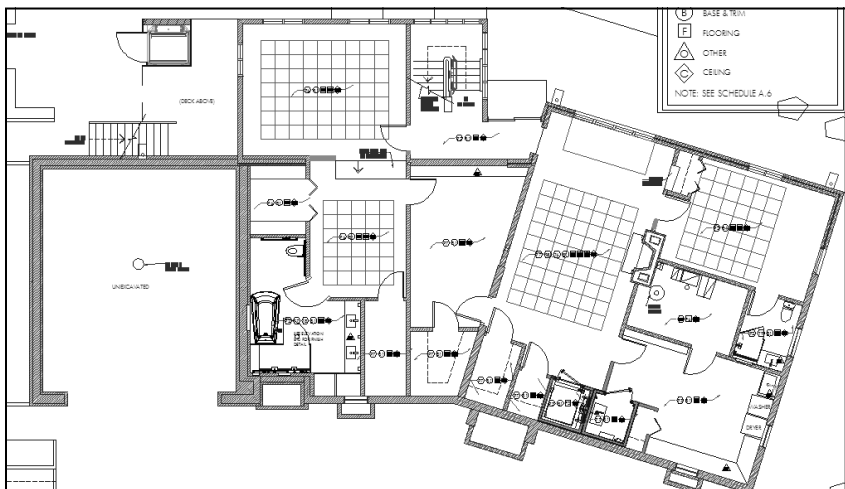

Figure 41. Post-renovation lower level finish floor plan.

References

- Administration on Aging. (2012). *Aging into the 21st century*. Retrieved from http://www.aoa.gov/AoARoot/Aging_Statistics/future_growth/aging21/preface.aspx
- ALS Association. (© 2013a). ALS (amyotrophic lateral sclerosis). *Glossary of Terms*. Retrieved from <http://www.alsa.org/research/glossary>
- ALS Association. (© 2013b). *Facts you should know*. Retrieved from <http://www.alsa.org/about-als/facts-you-should-know.html>
- ALS Association. (© 2013c). *Forms of ALS*. Retrieved from <http://www.alsa.org/about-als/forms-of-als.html>
- ALS Association. (© 2013d). *Genetic testing for ALS*. Written by Gaudette, M.; updated by Kinsley, L. Retrieved from <http://www.alsa.org/about-als/genetic-testing-for-als.html>
- ALS Association. (© 2013e). *Symptoms: Initial symptoms of the disease*. Retrieved from <http://www.alsa.org/about-als/symptoms.html>
- ALS Association. (© 2013f, rev. February 2011). *Who gets ALS?* Retrieved from <http://www.alsa.org/about-als/who-gets-als.html>
- American Association of Retired Persons. (n.d.). *Boomers Turning 65*. Retrieved from http://www.aarp.org/personal-growth/transitions/boomers_65/
- American Association of Retired Persons. (2000). *Fixing to stay: A national survey on housing and home modification issues*. Washington, DC, USA: Bayer, A. & Harper, L. Retrieved from http://assets.aarp.org/rgcenter/il/home_mod.pdf
- American Association of Retired Persons. (2010). *Home and Community Preferences of the 45+ Population*. Washington, DC, USA: Keenan, T. A.

- Aneshensel, C. S., Wight, R. G., Miller-Martinez, D., Botticello, A. L., Karlamangla, A. S., & Seeman, T. E. (2007). Urban neighbourhoods and depressive symptoms among older adults. *Journal of Gerontology: Series B Social Sciences*, 62, S52–S59.
- Aslaksen, F., Bergh, S., Bringa, O. R., & Heggem, E. K. (1997). *Universal Design: Planning and Design for All*. Oslo, Norway: Norwegian State Council on Disability.
- Bath, P. A. & Gardiner, A. (2005). Social engagement and health and social care use and medication use among older people. *European Journal of Ageing*, 2(1): 56–63.
- Bennett, K. M. (2005). Social engagement as a longitudinal predictor of objective and subjective health. *European Journal of Ageing*, 2(1):48–55.
- Brown, C. A., McGuire, F. A., & Voelkl, J. (2008). The link between successful aging and serious leisure. *International Journal of Aging and Human Development*, 66(1):73–95.
- Callahan, J. J. (Ed.), (1993). *Aging in place*. Amityville, NY: Baywood.
- Carr, K., Weir, P. L., Azar, D., Azar, N. R. (2013 January 30). Universal design: A step toward successful aging. *Journal of Aging Research*. 2013:324624. doi: 10.1155/2013/324624
- Center for Universal Design. (© 1998). *The Universal Design File*. p.34-35
- Center for Universal Design. (2006). *FACTsheet #6 DEFINITIONS: Accessible, Adaptable, and Universal Design*. Retrieved from http://www.ncsu.edu/ncsu/design/cud/pubs_p/docs/Fact%20Sheet%206.pdf
- Chatterji, P., Burstein, N. R., Kidder, D., & White, A. (1998). Evaluation of the Program of All-Inclusive Care for the Elderly (PACE) demonstration: The impact of PACE on participant outcomes. Cambridge, MA: Abt Associates.

Commission for Architecture and the Built Environment. (2008). *Inclusion By Design:*

Equality, Diversity and the Built Environment. London, UK: Seacout.

Crews, D. E. & Zavotka, S. (2006). Aging, disability, and frailty: implications for universal design. *Journal of Physiological Anthropology*, 25(1): 113–118.

Danford, G. S. (2003). Universal design people with vision, hearing, and mobility impairments evaluate a model building. *Generations*, 27(1):91–94.

Davey, J., Nana, G., de Joux, V., & Arcus, M. (2004). Accommodation options for older people in Aotearoa/New Zealand. *NZ Institute for Research on Ageing/Business & Economic Research Ltd, for Centre for Housing Research Aotearoa/New Zealand*.

Demirbilek, O. & Demirkan, H. (2004). Universal product design involving elderly users: a participatory design model. *Applied Ergonomics*, 35(4): 361–370.

Demirkan, H. (2007). Housing for the aging population. *European Review of Aging and Physical Activity*, 4(1): 33–38.

Eng, C., Pedulla, J., Eleazer, G. P., McCann, R., & Fox, N. (1997). Program for All-inclusive Care the Elderly (PACE): An innovative model of integrated geriatric care and financing. *Journal of the American Geriatrics Society*, 45, 223–232.

Erlandson, R. F. (n.d.). *Universal and Accessible Design Principles*. Retrieved from

<http://www.etl-lab.eng.wayne.edu/adrc/Definitions/UAD4.htm>

Fone S. & Lundgren-Lindquist, B. (2003). Health status and functional capacity in a group of successfully ageing 65–85 years olds. *Disability and Rehabilitation*, 25(18):1044–1051.

- Gitlin, L. N., Miller, K. S., & Boyce, A. (1999). Bathroom modifications for frail elderly renters: Outcomes of a community-based program. *Technology and Disability*, 10, 141–149.
- Glass, T. A., Mendes de Leon, C., Marottoli, R. A., & Berkman, L. F. (1999). Population based study of social and productive activities as predictors of survival among elderly Americans. *British Medical Journal*, 319(7208): 478–483.
- Gliderbloom, J. I., & Markham, J. P. (1996). Housing modification need of the disabled elderly: What really matters? *Environment and Behavior*, 28, 512–535.
- Grundy, E. & Bowling, A. (1999). Enhancing the quality of extended life years. Identification of the oldest old with a very good and very poor quality of life. *Aging and Mental Health*, 3(3): 199–212.
- Guse, L. W. & Masesar, M. A. (1999). Quality of life and successful aging in long-term care: perceptions of residents. *Issues in Mental Health Nursing*, 20(6): 527–539.
- Hall, P. & Imrie, R. (1999). Architectural practices and disabling design in the built environment. *Environment and Planning B*, 26(3): 409–425.
- Hutchings, B. L., Olsen, R. V., & Moulton, H. J. (2008). Environmental evaluations and modifications to support aging at home with a developmental disability. *Journal of Housing for the Elderly*, 22, 286–310.
- Hwang, E., Cummings, L., Sixsmith, A., & Sixsmith, J. (2011). Impacts of Home Modifications on Aging-in-Place. *Journal of Housing For the Elderly*, 25:3, 246-257.
doi: 10.1080/02763893.2011.595611

- Iwarsson, S. & Ståhl, A. (2003). Accessibility, usability and universal design—positioning and definition of concepts describing person-environment relationships. *Disability and Rehabilitation*, 25(2): 57–66.
- Keates, S., Clarkson, P. J., Harrison, L.A., & Robinson, P. (Nov 2000). Towards a practical inclusive design approach. Proceedings of the Conference on Universal Usability; New York, NY, USA. pp. 45–52.
- Keeling, S. (1999). Ageing in (a New Zealand) place: Ethnography, policy and practice. *Social Policy Journal of New Zealand*, 13, 95–114.
- Kose, S. (1998). From barrier-free to universal design: an international perspective. *Assistive Technology*, 10(1): 44–50.
- Lawler, K. (2001). Aging in place: Coordinating housing and health care provision for America's growing elderly population. *Joint Center for Housing Studies of Harvard University & Neighbourhood Reinvestment Corporation*.
- Liu, S. Y. & Lapane, K. L. (2009). Residential modifications and decline in physical function among community-dwelling older adults. *The Gerontologist*, 49(3): 344–354.
- Lomen-Hoerth, C. (2012). *ALS and Frontotemporal Dementia*. Webinar. Retrieved from http://www.alsa.org/assets/files/lomen_hoerth-webinar_ftld-and-als.pdf
- Marek, K. D., Popejoy, L., Petroski, G., Mehr, D., Rantz, M., Lin, W. (2005). Clinical outcomes of aging in place. *Nursing Research*, 54(3), May/June 2005, 202–211. Retrieved from http://ry7wh7fe2u.search.serialssolutions.com/?ctx_ver=Z39.88-2004&ctx_enc=info%3Aofi%2Fenc%3AUTF-8&rft_id=info:sid/summon.serialsolutions.com&rft_val_fmt=info:ofi/fmt:kev:mtx:journal&rft.genre=article&rft.atitle=Clinical+Outcomes+of+Aging+in+Place&rft.jtitle=Nursing+Research&rft.au=

Marek%2C+Karen+Dorman&rft.au=Popejoy%2C+Lori&rft.au=Petroski%2C+Greg
&rft.au=Mehr%2C+David&rft.date=2005-05-01&rft.issn=0029-6562&rft.eissn=
1538-9847&rft.volume=54&rft.issue=3&rft.spage=202&rft.epage=211&rft_id=
info:doi/10.1097%2F00006199-200505000-00008&rft.externalDBID=
n%2Fa&rft.externalDocID=10_1097_00006199_200505000_00008

Mattimore, R. J., Wenger, N. S., Desbiens, N. A., Teno, J. M., Hamel, M. B., Liu, H., et al.
(1997). Surrogate and physician understanding of patients' preferences for living
permanently in a nursing home. *Journal of the American Geriatrics Society*, 45(7),
818–824.

Moody, H. (Oct 2008). Aging in place: Ideals and realities. *The Gerontologist*, 48, 151-151.
Retrieved from <http://ezproxy.emich.edu/login?url=http://search.proquest.com/docview/211035664?accountid=10650>

Moriarty, J., & Butt, J. (2004). Inequalities in quality of life among older people from
different ethnic groups. *Ageing & Society*, 24, 729–753.

National Institute of Neurological Disorders and Stroke. (2012). "Amyotrophic Lateral
Sclerosis (ALS) fact sheet." NIH Publication No.12-916. Retrieved from http://www.ninds.nih.gov/disorders/amyotrophiclateralsclerosis/detail_ALS.htm

Pynoos, J., & Liebig, P. S. (Eds.). (1995). *Housing frail elders*. Baltimore, MD: The Johns
Hopkins University Press.

Rentz, S., Boltz, M., & Capezuti, E. (2004). Nursing home relocation stress syndrome.
Gerontologist, 44 (Special Issue I), 400.

Rowe, J. W. & Kahn, R. L. (1987). Human aging: usual and successful. *Science*,
237(4811):143–149.

Rowe, J. W. & Kahn, R. L. (1997). Successful aging. *The Gerontologist*, 37(4): 433–440.

Rowles, G. D. (1993). Evolving images of place in aging and ‘aging in place’. *Generations*, 17, 65–70.

Rubinstein, R. L. (1990). Personal identity and environmental meaning in later life. *Journal of Aging Studies*, 4, 131–147.

Silverstein, M. & Parker, M. G. (2002). Leisure activities and quality of life among the oldest old in Sweden. *Research on Aging*, 24(5):528–547.

Sixsmith, A. and Sixsmith, J. (2008). Ageing in place in the United Kingdom. *Ageing International*, 32: 219–235.

Stein, J. (2004). Understanding the ABCs of ADA. *Building Operating Management*, 51(1), 49-49. Retrieved from <http://ezproxy.emich.edu/login?url=http://search.proquest.com/docview/203434247?accountid=10650>

Stein, M. (2002). Americans with Disabilities Act. *Dictionary of American History*, 3rd ed. Charles Scribner's Sons (an imprint of the Gale Group), Forthcoming. Retrieved from http://papers.ssrn.com/sol3/papers.cfm?abstract_id=299304

Story, M. F. (1998). Maximizing usability: the principles of universal design. *Assistive Technology*, 10(1): 4–12.

Story, M. F., Mueller, J. L., & Mace, R. L. (1998). *The Universal Design File*. The Center for Universal Design. Retrieved from <http://design-dev.ncsu.edu/openjournal/index.php/redlab/article/viewFile/102/56>

Taylor, S. A. P. (2001). Place identification and positive realities of aging. *Journal of Cross-Cultural Gerontology*, 16, 5–20.

- U.S. Census Bureau. (2011a). *2011 American Community Survey*. Retrieved from http://factfinder2.census.gov/faces/tableservices/jsf/pages/productview.xhtml?_afpt=table
- U.S. Census Bureau. (2011b). *The Older Population: 2010*. Werner, C. A. Issued Nov 2011. doi: C2010BR-09. Retrieved from <http://www.census.gov/prod/cen2010/briefs/c2010br-09.pdf>
- U.S. Census Bureau. (2012). *2012 National Population Projections: Projections of the Population by Selected Age Groups and Sex for the United States: 2015 to 2060*. Retrieved from <http://www.census.gov/population/projections/data/national/2012/summarytables.html>
- U.S. Census Bureau. (2012). *2012 National Population Projections: Percent Distribution of the Projected Population by Selected Age Groups and Sex for the United States: 2015 to 2060*. Retrieved from <http://www.census.gov/population/projections/data/national/2012/summarytables.html>
- Verbrugge, L. M. & Jette, A. M. (1994). The disablement process. *Social Science and Medicine*, 38(1): 1–14.
- Wahl, H. W., Fänge, A., Oswald, F., Gitlin, L. N., & Iwarsson, S. (2009). The home environment and disability-related outcomes in aging individuals: what is the empirical evidence? *The Gerontologist*, 49(3):355–367.
- Wiggins, R. D., Higgs, P. F. D., Hyde, M., & Blane, D. (2004). Quality of life in the third age: Key predictors of the CASP-19 measure. *Ageing & Society*, 24, 693–708.

Wiles, J. L., Leibing, A., Guberman, N., Reeve, J., Allen, R. E. S. (2012). The meaning of “aging in place” to older people. *The Gerontologist*, 52(3): 357-366 first published online October 7, 2011. doi:10.1093/geront/gnr098

APPENDICES

APPENDIX A: INTERVIEW QUESTIONNAIRE

1. How do you feel about your home now? This can relate to emotional or psychological feelings and/or feelings about specific parts of your home.
2. What things and/or areas in your home would you like to change?
3. What are your goals for your home in this design?
4. What kind of feeling, aesthetic, style, and/or quality are you hoping to have in your home?
5. Describe the financial issues of a couple in your situation and/or stage of life.
6. What is your budget for this project, and how flexible is the budget?
7. What are your priorities in the design that will help direct where the budget is focused?
8. Where do you want to live as you age and as your abilities change?

APPENDIX B: RECRUITMENT SCRIPT

Recruitment Script for Email to Potential Subjects

Project Title: Balancing Design Theories and Individual Needs in Residential Modifications for People Living with ALS

Investigator: Gail Weber, Eastern Michigan University

Co-Investigator: Shinming Shyu, Ph.D., Interior Design Graduate School Department Chair

Greetings!

I am a graduate student working toward my Master's degree in Interior Design at Eastern Michigan University, and I am focusing my thesis on universal design, accessible design, aging in place, and ALS. I am seeking subjects for a case study so I can focus on design choices for people living with ALS. I specifically would like to interview one person living with ALS and that person's spouse. The subjects need to own their home and ideally would be considering making modifications to the home to make it more accessible to the person with ALS as the disease progresses.

If you are willing to participate, I would meet with you and ask you eight questions. The questions relate to your home and what you need and want in any upcoming modifications, as well as your feelings about the concept of aging in place. There is no minimum or maximum length of response to the questions and there are no right and wrong answers. You may take as long as you need to respond to each question or prompt. The approximate total time to complete the interview should be about 20 minutes. The interview will be recorded so I can accurately apply your responses in the research and design. Your thoughts on these questions would provide helpful information for my research and they would also help me make better-informed decisions in the design portion of my thesis.

In addition, I would visit your home, evaluate its current state, and compare it to the Americans with Disabilities Act Accessibility Guidelines (ADAAG) and the Universal Design Guidelines to establish areas that could be improved in relation to independent functioning, mobility, and safety. I would then apply your interview responses and information from the home evaluation to discuss and illustrate potential design solutions for your home to increase its function, mobility, safety, and resale value in relation to the ADAAG, Universal Design Guidelines, and your specific needs as people living with ALS. The design solutions, which will include floor plans, elevations, and renderings of the subjects' home, will be included in the written research paper and in a detailed set of architectural drawings. Case study subjects will receive a copy of the written research paper and the architectural drawings. The approximate total time for me to complete the home evaluation will be about one hour.

(Recruitment Script for Email to Potential Subjects, continued)

The identities of the subjects will be revealed only as Subject 1 and Subject 2 in the written thesis, architectural drawings, and in any other related publications and presentations. The subjects' genders, address, street, city, and state will not be disclosed in the written thesis, architectural drawings, or in any other related publications and presentations.

You have the right to refuse to participate in this study, and there are no negative consequences if you do not participate. If you agree to participate in the study, you also have the right to withdraw from the study at any time with no negative consequences.

Please let me know if you would be willing to be my case study subjects. If you are, I will send you an informed consent form for you to read, and if you agree to the terms, please print it, sign it, and mail it back to me.

Thank you for your consideration!

Sincerely,
Gail J. Weber

APPENDIX C: LETTER APPROVING USE OF HUMAN OR ANIMAL

SUBJECTS

Informed Consent

Project Title: Balancing Design Theories and Individual Needs in Residential Modifications for People Living with ALS

Investigator: Gail Weber, Eastern Michigan University

Co-Investigator: Shinming Shyu, Ph.D., Interior Design Graduate School Department Chair

Purpose of the Study: The purpose of this research study is to explore the design needs and preferences of one couple living with amyotrophic lateral sclerosis (ALS) and examine the philosophies and psychological factors of aging in place and universal design, as well as the Americans with Disabilities Act Accessibility Guidelines (ADAAG), to gain a better understanding of how they can be realistically applied in interior design for people living with ALS.

Procedure: The research investigator will explain the study to you, answer any questions you may have, and witness your signature to this consent form. You must be a person with ALS or a person with ALS's spouse to take part in this study. The study will consist of two parts. The first part, an interview, will have eight questions or prompts. The researcher will ask you these questions in an in-person interview and will record your responses. The questions relate to your home and what you need and want in its upcoming modifications, as well as your feelings about the concept of aging in place. There is no minimum or maximum length of response. Take as long as you need to respond to each question or prompt. Upon completing the interview questions, you will be given a duplicate copy of this informed consent, which includes follow-up contact information, if needed. The approximate total time to complete the interview should be about 20 minutes.

In the second part of the study, the researcher will visit your home, evaluate its current state, and compare it to the Americans with Disabilities Act Accessibility Guidelines (ADAAG) and the Universal Design Guidelines to establish areas that could be improved in relation to independent functioning, mobility, and safety. The researcher will then apply your interview responses and information from the home evaluation to discuss and illustrate potential design solutions for your home to increase its function, mobility, safety, and resale value in relation to the ADAAG, Universal Design Guidelines, and your specific needs as people living with ALS. The design solutions will be included in the written thesis and in a detailed set of architectural drawings. Case study subjects will receive a copy of the written thesis and the architectural drawings. Upon completing the home evaluation, you will be given a duplicate copy of this informed consent, which includes follow-up contact information, if needed. The approximate total time for the researcher to complete the home evaluation will be about one hour.

(Informed Consent, continued)

Confidentiality: To maintain your confidentiality, only the names Subject 1 or Subject 2 will identify your interview responses. Some of your responses may be directly or indirectly quoted within the research paper, but at no time will your name be associated with your responses to the questionnaire. The design solutions, which will include floor plans, elevations, and renderings of the your home, will be included in the written research paper and in a detailed set of architectural drawings, but your address, street, city, and state will not be disclosed on the documents or in any written or oral publications and presentations. All related materials will be kept in locked file cabinets in the researcher's home and electronic data will be stored on a password-protected computer.

Expected Risks: There are no foreseeable risks to you by completing this interview or home evaluation, as all identities will be kept confidential.

Expected Benefits: Anticipated benefits of participating in this study include an improved, more personalized design for your upcoming home modifications. In addition, your participation will help spread awareness of ALS to those who read the research paper or attend any research presentations.

Voluntary Participation: Participation in this study is voluntary. You may choose not to participate. If you do decide to participate, you can change your mind at any time and withdraw from the study without negative consequences.

Use of Research Results: Results will be presented in aggregate form only. No names or individually identifying information will be revealed. Results may be presented at research meetings and conferences, in scientific publications, and as part of a capstone graduate research project being conducted by the principal investigator.

Future Questions: If you have any questions concerning your participation in this study now or in the future, you can contact the principal investigator, Gail Weber (734.769.6994, gailjweber@gmail.com).

This research protocol and informed consent document will be reviewed and approved by the Eastern Michigan University Human Subjects Review Committee (UHSRC) for use from 03/21/2014 through 09/21/2014. If you have questions about the approval process, please contact the UHSRC at human.subjects@emich.edu or 734.487.0042.

(Informed Consent, continued)

Consent to Participate: I have read or had read to me all of the above information about this research study, including the research procedures, possible risks, side effects, and the likelihood of any benefit to me. The content and meaning of this information has been explained and I understand. All my questions, at this time, have been answered. I hereby consent and do voluntarily offer to follow the study requirements and take part in the study.

PRINT NAME: _____

Signatures:

Participant (your signature) _____ Date _____

Investigator or Specified Designee _____ Date _____

