

1-23-2009

# Crib dock permit and construction standards in the upper great lakes

Brian J. Hoxie  
*Eastern Michigan University*

Follow this and additional works at: <http://commons.emich.edu/theses>

 Part of the [Construction Engineering Commons](#)

---

## Recommended Citation

Hoxie, Brian J., "Crib dock permit and construction standards in the upper great lakes" (2009). *Master's Theses and Doctoral Dissertations*. 508.  
<http://commons.emich.edu/theses/508>

This Open Access Dissertation is brought to you for free and open access by the Master's Theses, and Doctoral Dissertations, and Graduate Capstone Projects at DigitalCommons@EMU. It has been accepted for inclusion in Master's Theses and Doctoral Dissertations by an authorized administrator of DigitalCommons@EMU. For more information, please contact [lib-ir@emich.edu](mailto:lib-ir@emich.edu).

Crib Dock Permit and Construction Standards  
in the  
Upper Great Lakes

Dissertation  
by  
Brian J. Hoxie

Submitted to  
The College of Technology  
Eastern Michigan University  
in partial fulfillment of the requirements for the degree of

DOCTOR OF PHILOSOPHY – TECHNOLOGY

Dissertation Committee:  
Daniel J. Fields, Ph.D., Chair  
Benedict Ilozor, Ph.D.  
William A. Moylan, Ph.D.  
William F. Welsh, Ph.D.

January 23, 2009  
Ypsilanti, Michigan

## DEDICATION

I dedicate this work, and the journey it culminates, to my wife, Michele, and our children, Angela and Aleks. Without their love and support, life has no meaning, accomplishments no reward.

## ACKNOWLEDGEMENTS

I would like to extend my sincere thanks and gratitude to the many individuals who contributed to my completion of this project and degree. In particular, my dissertation chair and committee members for their dedication and guidance: Dan Fields, who served not only as my advisor and committee chair, but as a role model, mentor, and friend; Benedict Ilozor, who always emphasized rigor and quality and never to be satisfied, always look to make the end-product just a bit better; Bill Moylan, for his extensive construction management experience and practical perspective; and Bill Welsh, who consistently provided a fresh perspective, brought the conversation back to the environment as well as the construction issues, and for providing Bryan Debus, who completed the excellent GIS analysis. I'd also like to thank all the other many faculty members and campus colleagues along the way who took time to give me assistance and encouragement when things seemed a bit too hard. A special thanks to my friends and colleagues in Academic Programming and the Provost's staff for their understanding when my focus on daily pursuits faltered due to academic distractions and concerns. And a special, deeply heartfelt thanks to my friends, fellow grippers, and program colleagues in the Eastern Michigan University College of Technology Doctoral Program. Without your comradeship, counsel, critique, and support, this would have been a far more onerous task to complete.

## ABSTRACT

This study explored the permitting, design, and construction of crib docks in the Les Cheneaux and Drummond Island region of Michigan. It employed an exploratory two-phase mixed-methods research design: first to qualitatively explore and define the problem, and then to quantitatively evaluate a convenience sample of crib docks to determine appropriate permit and construction norms that meet functional requirements while addressing ecological and waterway concerns. The variables considered included siting, design, superstructure, and ground anchorage.

The qualitative findings demonstrated that the USACE and MDEQ are the approving agencies for crib docks and oppose new crib dock construction permits, because they consume Great Lakes bottomland and create waterway obstacles. While the agencies do approve crib dock construction permits, the norms are vague and ill-defined. Conversely, the USFS and MDNR promote the use of submerged crib-based structures to enhance fish habitat. The findings also showed that local governments consider crib docks to be temporary structures even though they last 30 years. Because they are temporary structures, the local governments do not require them to meet state residential construction code requirements. These contradictory position and lack of code standards leaves dock applicants in a confusing, frustrating position. The quantitative findings reflected the lack of code enforcement and showed that crib docks could be made significantly safer and more environmentally friendly by imposing key design and structural norms.

The conclusions and recommendations outline government policy actions to better define the crib dock approval process and propose standards for the approval and

construction of crib docks. The recommendations also outline additional research to further clarify the remaining inconsistencies in this multi-jurisdictional construction code issue.

## TABLE OF CONTENTS

DEDICATION .....	ii
ACKNOWLEDGEMENTS .....	iii
ABSTRACT .....	iv
LIST OF TABLES .....	x
LIST OF FIGURES.....	xi
CHAPTER 1: INTRODUCTION .....	1
Problem Statement .....	4
Nature of the Problem .....	5
Research Objective.....	7
Research Questions .....	8
Research Design.....	8
Delimitations .....	9
Assumptions.....	10
Limitations .....	11
Study Significance.....	12
Definitions.....	13
Chapter Summary.....	16
Report Overview .....	16
CHAPTER 2: REVIEW OF RELATED LITERATURE.....	18
Literature Related to the Problem .....	18
Construction Codes & Permit Processes.....	19
Environmental Laws & Permit Processes.....	25

Environmental Effects of Crib Docks .....	32
Crib Dock Siting & Design Considerations .....	38
Literature Related to the Research Design .....	44
Recent History of Mixed Methods Research .....	44
Mixed Methods Advantages and Challenges .....	46
Mixed Method Designs .....	47
Grounded Theory .....	49
Direct Measurement Research .....	50
Chapter Summary.....	51
Summary of the Literature Related to the Problem.....	52
Summary of the Literature Related to the Research Design .....	54
Closing .....	56
<b>CHAPTER 3: RESEARCH METHODOLOGY &amp; DESIGN.....</b>	<b>57</b>
Research Objective and Questions.....	57
Methodology Selection .....	58
Variable Definition.....	59
Qualitative Phase - Grounded Theory.....	59
Qualitative Population & Sample Design .....	60
Qualitative Instrumentation.....	61
Human Subjects Review and Approval .....	61
Qualitative Data Collection.....	62
Qualitative Data Analysis.....	63
Quantitative Phase - Direct Measurement.....	64
Quantitative Population & Sample Design .....	64



Quantitative Instrumentation.....	65
Quantitative Data Collection.....	66
Quantitative Data Analysis.....	66
Data Integration and Analysis.....	68
Integrated Data Analysis.....	68
Integrated Data Validation.....	68
Chapter Summary.....	69
<b>CHAPTER 4: PRESENTATION &amp; ANALYSIS OF FINDINGS.....</b>	<b>71</b>
Research Objective & Questions.....	71
Qualitative Phase - Grounded Theory.....	72
Qualitative Data Collection.....	72
Qualitative Sample Analysis.....	73
Qualitative Data Analysis.....	75
Qualitative Data Validation.....	86
Quantitative Phase - Direct Measurement.....	89
Quantitative Data Collection.....	89
Quantitative Sample Analysis.....	89
Quantitative Data Analysis.....	90
Quantitative Data Validation.....	101
Integrated Findings.....	105
Integrated Data Analysis.....	105
Integrated Data Validation.....	111
Chapter Summary.....	114
<b>CHAPTER 5: CONCLUSIONS &amp; RECOMMENDATIONS.....</b>	<b>138</b>
Summary of Chapters 1- 4.....	138

Introduction .....	138
Review of Related Literature .....	139
Research Methodology & Design .....	140
Presentation & Analysis of Findings.....	140
Conclusions .....	146
Governmental Oversight of Crib Dock Construction .....	146
Crib Dock Approval & Construction Standards .....	152
Limitations .....	160
Recommendations .....	163
Recommendations for Government Action.....	164
Recommendations for Further Study .....	167
Closing .....	170
REFERENCES.....	176
APPENDICES.....	184
Appendix A - MDEQ – USACE – Application for Minor Shore Activities Application Form and Instructions.....	185
Appendix B - Crib Dock Contractor Interview Guide .....	189
Appendix C - Crib Dock Owner Interview Guide .....	195
Appendix D - Government Official Interview Guide .....	197
Appendix E - Human Subjects Review Committee approval.....	202
Appendix F - Crib Dock Site Data Collection Form.....	204
Appendix G - Calculation of Lake Bottom Area Consumed by a Crib vs the Surface Area Created by a Crib.....	213
Appendix H - Dock Siting Detail Graphics .....	217
Appendix I - Recommended Michigan Crib Dock Permit & Construction Standards ...	228

## List of Tables

<u>Table</u>	<u>Page</u>
1. Deck Joist Spans for Common Lumber .....	44
2. Variable Definition.....	60
3. Qualitative Phase Sample Analysis.....	74
4. Crib Dock Sample - Site Data Set.....	120
5. Crib Dock Sample - Crib Data Set.....	123
6. Crib Dock Sample - Superstructure Data Set.....	130
7. Crib Dock Sample Set - Ground Anchorage Data Set.....	132
8. Recommended Crib Dock Approval & Construction Standards .....	152

## List of Figures

<u>Figure</u>	<u>Page</u>
1. Crib Dock Sketch Drawing .....	3
2. Research Design Model .....	7
3. Research Area .....	9
4. Sample Drawing for Proposed Pier, Docks, & Piles.....	33
5. Sequential Exploratory Design.....	49
6. Crib dock with lakeward end angled to face anticipated ice load.....	79
7. Layout of a Basic 8 Foot Crib.....	81
8. Log Crib Constructed with no Spacing Between Cross Timbers.....	83
9. Dock Crib Being Constructed with the Floor In Place .....	83
10. Piling Groupings of 3 Placed at the Lakeward Corners.....	86
11. Crib Dock Data Set Geographic Analysis.....	91
12. Fetch Effect on Research Area during Oct - Dec.....	93
13. Fetch Effect on Research Area during Jan - Mar. ....	94
14. Summary of Crib Dock Configurations. ....	96
15. Oversized Crib Framework with Cross Bracing .....	98
16. Dock End Pilings with Close Interval Spacing and Corner Clusters. ....	102
17. Dock End Piling Corner Cluster with Cable Reinforcement. ....	102
18. Government Oversight of Crib Dock Construction. ....	147

# CHAPTER 1

## INTRODUCTION

For many, the Great Lakes shoreline is the “gold standard” for seasonal home ownership. Residents enjoy the natural beauty and recreational opportunities of the Great Lakes and want to own and develop property along or with access to this Michigan treasure. Meeting the construction needs of these Great Lakes shoreline homeowners is particularly challenging given the increasing emphasis on environmental stewardship and sustainable engineering. The design and construction of structures must meet owner needs, incorporate appropriate environmental stewardship, and support established local social values (Marsh, 2005, p. 18). This triangular interface brings into conflict multiple goals for commonly held lands and natural assets and often results in non-standard construction permit approval processes.

Take for instance the Les Cheneaux and Drummond Island region of Michigan’s eastern Upper Peninsula. This area, on the northern shore of Lake Huron roughly 30 miles east of St. Ignace, is one of the oldest seasonal vacation home communities in the state, if not the country. Since the 1880s, with the establishment of the Les Cheneaux Club, the region’s miles of island and channel shoreline have provided highly desirable seasonal home sites (Grover, 1911, p. 96). Typically these seasonal homes consist of a primary residence, minimal landscaping, and docking for pleasure boats. The docks may even be the primary access for homes located on islands. However, unlike docks on inland lakes, docks in this region are built in Lake Huron even though they may not directly face the lake. Since these

docks are built in one of the Great Lakes, they are built on public land in accordance with the Great Lakes Submerged Lands Act:

The bottomlands of the Great Lakes are held in trust by the State of Michigan for use and enjoyment by its citizens. The State, as the owner and trustee, has a perpetual responsibility to the public to manage these bottomlands and waters for the prevention of pollution, for the protection of the natural resources and to maintain the public's rights of hunting, fishing, navigation, and commerce. (NREPA, Part-325, 1994)

As a result, pleasure craft docks in the region fall under multiple jurisdictions with differing, often conflicting, goals and objectives. Approval of dock construction is granted by the Michigan Department of Environmental Quality (MDEQ) in concert with the U.S. Army Corps of Engineers (USACE). The MDEQ's Land and Water Management Division has primary responsibility for overseeing the Great Lakes bottomlands through enforcement of the Submerged Lands Act. The Corps is involved because it is responsible for maintaining the nation's navigable waterways, in concert with The Rivers and Harbors Act of 1899; all of the Great Lakes are considered navigable waterways. However, these agencies are essentially concerned only with minimizing a proposed dock's impact on the environment and obstruction to other waterway users. Their permitting process does not address the proposed dock's structural integrity or safety implications. These kinds of issues should be addressed in Michigan's Residential Code or local township ordinances, but rarely are. For instance in the Les Cheneaux region, the Clark Township boathouse ordinance covers whatever is built on the dock, but not the dock itself. It merely states that "The Clark Township Building Inspector shall approve the structural integrity of the boathouse" (Clark Township Boathouse Ordinance, 2002).

This problem is further complicated by the predominant dock structures used in the region, crib docks. A crib dock consists of a deck frame and surface supported by a timber crib pier (Figure 1). The crib pier "...is a large box that sits on the bottom of the lake and supports the dock. The crib is filled with rocks for weight and stability" (IRNP, 2004, p. 11). Historical photographs show this style dock in use throughout the area since the late 1800s (Pittman, 1984, Plate 62). As Chapter 2 discusses in greater detail, crib docks offer key



*Figure 1.* Crib Dock Sketch Drawing (Burns, 2004, p. 17).

structural advantages while posing some environmental advantages and concerns. The two key structural advantages are: 1) they are strong enough to withstand most lateral ice loading, and 2) they are flexible enough to accommodate the episodic vertical ice loads caused by seiche. Seiche is a short-term fluctuation in Great Lakes coastal water levels caused by strong winds and barometric pressure differential. These effects will push the water to one side of the lake and then subsequently relax and allow the water level to drop, much like water sloshing in a bowl. The fluctuations can vary from a few inches to several

feet and last from a few minutes to a day (NOAA\_Coast\_Pilot\_6, 2007, p. 168). In the wintertime, the seiche causes ice jacking. Ice jacking results from surface ice gripping pilings or piers as it freezes, then rising with the seich, and subsequently relaxing. In the course of a fall-winter season, this seiche ice jacking cycle can occur multiple times and physically pull typical dock pilings out of the ground, whereas crib docks' flexibility and unitary structure will, to a great extent, accommodate ice jacking. They can be lifted and resettled without structural damage.

On the environmental side of the equation, the primary advantage is that the cribs provide a complex habitat, which supports and protects young fish, known as fry, and attracts sport fish. The U.S. Forest Service encourages putting wood cribs in lakes specifically to enhance sport fish habitat and enhance fish populations (Bassett, 1994; Gringras, 2005). On the other hand, the MDEQ is opposed to crib docks primarily because of the crib pier itself. The pier's weighted box structure covers and compacts the lake bottom, interfering with shore zone ecosystems and currents, typically an active habitat for marine life (ASCE, 1994, p. 140). These advantages and disadvantages, as well as other considerations, present construction permitting officials with a complex multi-attribute decision challenge.

### Problem Statement

The multi-attribute nature of the approval process has led to ill-defined and confusing design, approval, and construction standards for the predominant pleasure craft docking structure in this major recreational community of northern Michigan. The typical designs used by regional contractors are based, to a degree, on what will be approved by the MDEQ



and USACE, as opposed to what is structurally sound and functionally safe for the customer, and architecturally appropriate for the community.

### Nature of the Problem

Design standards establish the minimum acceptable structural and material requirements for a constructed facility, while construction standards and regulations govern the methods and means used by a contractor to build a facility. These standards are typically set forth in building codes, which have been in use in the United States since the 1600s. The first western hemisphere building code was established in New Amsterdam, New York, in 1625, to minimize fire danger by specifying the roofing materials that could be used on buildings (Syal & Shay, 2001, p. 1). The development of building codes continued sporadically over time but took on a more defined nature in the late 1800s as an outgrowth of industrialization and the nascent public health movement. In 1896, in response to a number of large-scale metropolitan fires, the fire insurance industry banded together to establish fire prevention building codes to minimize insurance claims. Similarly, as urban populations became more concentrated, the environment's ability to absorb human waste was overwhelmed, and unabsorbed waste began to degrade drinking water and public health. Situations of this nature led local and city governments to impose building standards to ensure the safety and well-being of building occupants as well as the general public. These initial codes, and associated basic permitting, have expanded over the years to include structural integrity, utility safety, and environmental protection, both during and after construction. However, in each of these general categories, the permitting standards were developed, and still are, based on norms derived from the technological understanding of the

issue. Clearly these standards have changed and evolved over the years, but normally in response to a more complete and balanced understanding of the permit issues and the societal implications.

However, for the crib dock construction approval process, the construction permit approval agencies are focused on environmental and waterways issues without any defined consideration for the structural aspects of the proposed dock structures. In essence, the problem centers on the size of the cribs and associated superstructure. The MDEQ and USACE would prefer the cribs and docks to be as small as possible. This minimizes lake bed occupation, interference with littoral flow, disruption of lake bottom and riparian vegetation, and waterway obstructions. All are established goals of the MDEQ and USACE crib dock permitting process. However, docks with undersized cribs and limited superstructure will not withstand winter ice loading or provide adequate structural strength to support dock usage purposes like boat storage houses or secure moorage points. These opposing goals, environmental and structural, must be balanced in the approval process. The primary approval agencies are focused on the environmental aspects of the approval process, while the owner and builder are primarily concerned with the structural issues. This can lead to dock owner and builder frustration with what appears to be a capricious, contradictory approval process. The centerpiece of this frustration stems from the lack of formally validated standards, structural or environmental, for the siting, design, and construction of crib docks, standards that ensure both the dock owner and the greater public's goals are satisfied in a reasonable, balanced manner.

## Research Objective

This research evaluated crib dock construction methods throughout the Les Cheneaux and Drummond Island region to establish defined permit and construction norms that meet the structural needs of owners, while respecting the greater public's desire to maintain safe waterways and protect the Great Lakes bottomland and associated water life and vegetation. Given the nature of this problem and the limited literature or other baseline information related to the problem, the study used a mixed methods sequential exploratory strategy, using Grounded Theory in the initial qualitative phase and Direct Measurement in the subsequent quantitative phase (Figure 2). The first phase was a qualitative exploration of crib dock construction methods by interviewing crib dock construction contractors from the

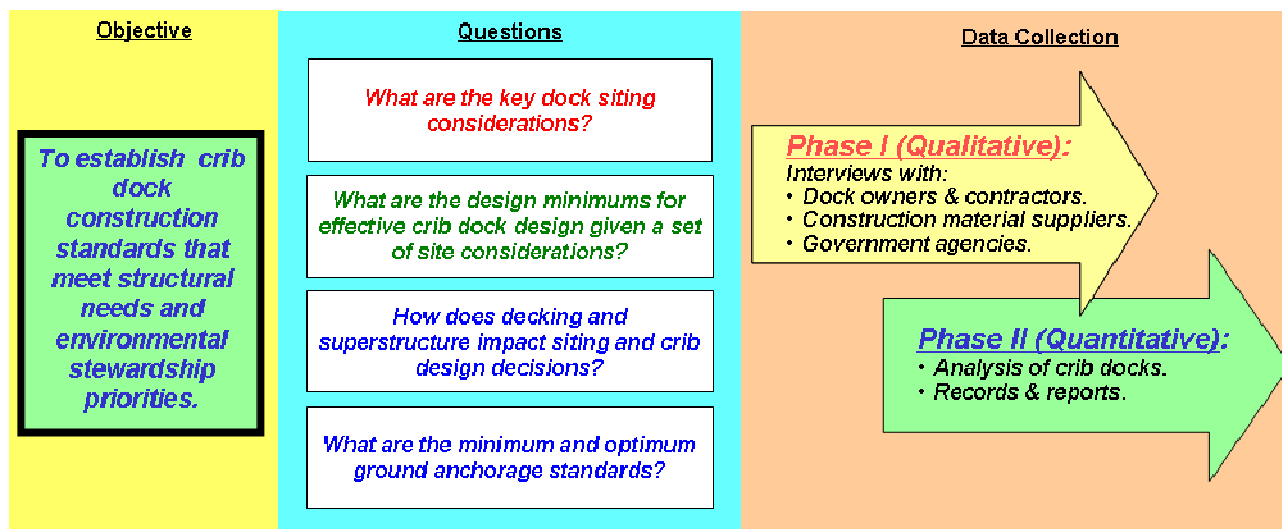

Figure 2. Research Design Model

communities of Cedarville, Hessel, and Drummond Island. The understanding of crib dock construction methods developed in the first phase was then used to develop a dock evaluation instrument. The instrument was used in the quantitative phase to guide collection of

structural data on sound, safe, effective docks in use throughout the region. The data collected were used to identify norms for consideration and adoption by the state as defined crib dock approval and construction standards.

### Research Questions

The research questions addressed were:

- What are the key crib dock siting considerations? How does dock siting and orientation affect weather loads and associated durability?
- What are the crib design and construction minimums for a given set of site considerations?
- How does the decking and superstructure affect siting and crib design decisions?
- What are the minimum and optimum ground anchorage standards for appropriate design and durability?

### Research Design

As portrayed by the research model (Figure 2), the study pursued the research questions in two phases:

- 1) Interviews with crib dock builders, owners, construction material suppliers, and government officials involved with approving and inspecting crib dock construction projects.
- 2) Analysis of in-service crib docks, both recently completed and older serviceable docks, and any available construction and maintenance records.

### *Delimitations*

The study population consisted of crib dock owners, builders, construction material suppliers, government officials, and completed docks built along Michigan's northern Lake Huron shoreline, in the Les Cheneaux and Drummond Island region (Figure 3). The theoretical population is all crib dock owners, builders, and docks in Michigan's northern Great Lakes region. The theoretical population is limited to Michigan, because construction codes are a state government function. The study employed a purposive sample of established dock builders and a convenience sample of owners and docks from the study region (Figure 3). A purposive sample is designed to achieve a specified purpose, in this case to contact and interview all of the identified crib dock contractors in the research area, whereas, a convenience sample is a sample based on the convenience of collecting the

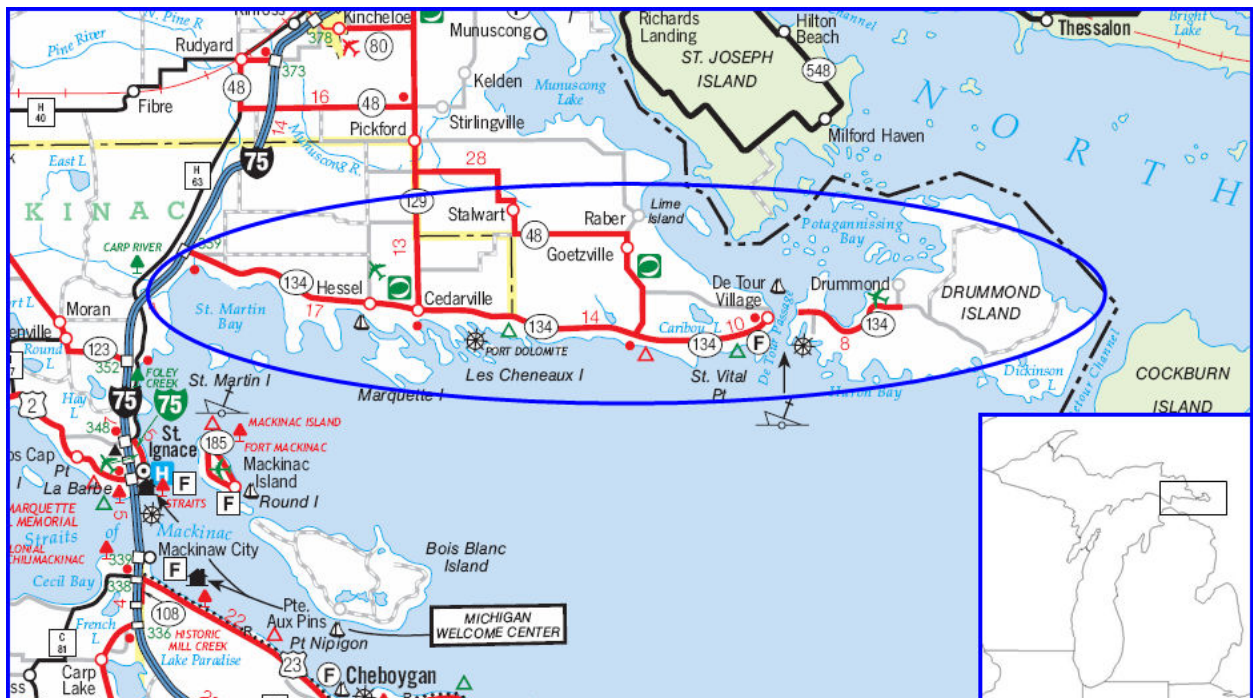

*Figure 3.* Research Area

sample elements, in this case the actual crib docks, which were selected based on the ability to conveniently access them. However, the study did not consider or address:

- Any formal structural analysis of crib dock designs nor explore options for improving crib dock durability. Success in this area could significantly reduce maintenance and associated owner costs.
- Options for mitigating the environmental impact of crib dock construction. If environmental mitigation options appear workable, then efforts to adjust the regulatory standards that control crib dock design and employment will need to be pursued.
- The merit of any particular contractor's design or construction methods as compared to others in the research area.
- Construction cost considerations, either design or material or construction techniques used.

#### *Assumptions*

The research proceeded based on a limited set of critical assumptions:

- Clearly established standards for siting, design, and construction of crib docks will greatly alleviate the vagaries of the crib dock design and construction approval process.
- Federal, state, and local government officials are interested in and willing to establish clearly defined standards for siting, design, and building of crib docks.

### *Limitations*

While crib docks are quite common in the research area, they are also found throughout the rest of northern Michigan, northern Minnesota, Wisconsin, the Rocky Mountains, and New England, as well as Canada. The study, however, was limited by the geographic constraint of the research area. The Upper Peninsula's Lake Huron shoreline is only about 50 miles in length. This relatively limited regional focus will need to be addressed in future research for the findings to have wider applicability. Future inquiry could be directed towards determining if the results of this work hold true for the northern areas of Lake Michigan, as well as Lake Superior and other regions of northern North America.

The research area is somewhat remote, which generates sampling limitations. While there are more than enough crib docks to support the study, there were only four formal crib dock construction contractors drawn from a close knit community with multiple societal connections. The contractor responses can not be considered totally independent of each other given their interconnectedness. In addition, many of the docks are accessible only by boat during warm weather or snowmobile during the winter season. Hence, the dock sample is weighted toward docks built on the mainland. The nature of these samples must be considered to ensure they do not inadvertently skew the results. Finally, due to the research area's remoteness, it was difficult to return to the area to verify oversights and clarify vagaries in the data. These issues will be addressed in the research design and findings discussions in Chapters 3 and 4.

## Study Significance

This study has significance from two important perspectives. First, as will be shown in the literature review, the construction of crib dock structures has not been addressed in any scholarly manner to date. For that matter, there is very little scholarly research on timber or crib-based structures at all. There was one study of timber crib retaining walls done at University of Idaho in the early 1970s (Schuster, Jones, Smart, & Sack, 1973). Also, a more recent examination of timber bridges was done at Virginia Technological University in 1994 (Smith, 1994). There are also references to crib based structures in a variety of commercial and military manuals. However, there has been no reasonably current work on structures of this type. This, in combination with the public safety issue due to the lack of construction standards, justifies further, disciplined inquiry.

In addition, the topic has broader implications as the interface between individual property rights and societal environmental priorities continues to be a point of conflict and dissatisfaction. In this case, property owners have invested significant personal wealth to obtain highly desirable shorefront property only to be told that they cannot build the dock that suits their needs and desires. However, the specific reasons for such a disapproval are not available due to the vague nature of the permit approval standards. Issues of this nature will become increasingly significant as public and governmental pressure related to environmental issues continues to grow. The results of this study will be provided to the appropriate government agencies for consideration and possible codification of the crib dock approval process. The findings will add to the existing knowledge about resolving multiple jurisdictional construction issues in the era of sustainable construction technologies in



support of residential construction, both permanent and seasonal, in the ecologically sensitive Great Lakes region.

### Definitions

Listed below are definitions for the unusual terms, abbreviations, and acronyms used throughout this study report.

*ACQ*: abbreviation for Alkaline Copper Quaternary, an EPA approved water-based wood preservative that prevents wood decay from fungi and insects.

*Benthic*: refers to anything associated with or occurring on the bottom of a body of water.

*Direct Measurement*: a general quantitative research methodology that determines a population's characteristics by testing subjects or otherwise directly counting or measuring the population characteristics.

*Fetch*: the length of water over which a given wind blows unimpeded in reaching a specific shoreline location.

*Kip*: a kilo-pound or 1000 pounds of force.

*GFI*: stands for ground fault interrupt, a circuit device that protects a user from electrical shock by interrupting an electric circuit when a difference is detected between the current in the "hot" and neutral wires.

*GIS*: stands for geographic information system, which is a system for capturing, storing, analyzing, managing and presenting data that is spatially referenced.

*Grounded Theory*: a general qualitative research method focused on the systematic generation of theory from data that contains both inductive and deductive thinking.

*GPS:* stands for global positioning system, which is a part of the Global Navigation Satellite System. It uses a constellation of medium Earth orbit satellites that transmit precise microwave signals, enabling receivers to determine their precise geographic locations.

*Interstitial:* of, relating to, or situated in an interstice, which is a small opening or space between objects, especially between adjacent objects or objects set closely together.

*Ice Jacking:* the cyclic incremental extraction of a piling by an ice sheet as it repeatedly freezes, rises, thaws, and relaxes over the course of a winter season.

*Joist:* one of the horizontal supporting members that run from wall to wall, wall to beam, or beam to beam to support a ceiling, roof, or floor.

*Littoral:* the coastal area of an ocean, sea, large river, lake or estuary. In coastal environments, the littoral zone extends from the ordinary high water mark to the areas permanently submerged and deep enough that natural light does not reach the bottom.

*Littoral Current:* a current caused by waves as they strike shore and push water along the parallel to the shoreline, usually in the nearshore region within the breaker zone; also known as alongshore or longshore current.

*MDEQ:* stands for the Michigan Department of Environmental Quality, which is a Michigan state governmental agency responsible for protecting the state's environment through pollution prevention of the state's air, land, and water resources.

*MDNR:* stands for the Michigan Department of Natural Resources, which is a Michigan state governmental agency responsible for stewardship of the state's natural resources and for the provision of outdoor recreational opportunities.

*NREPA*: the Michigan Natural Resources and Environmental Protection Act, 1994 Public Act 451, which can be found at Michigan Compiled Laws 324.101 that address resource management and environmental protection.

*OHWM*: stands for the ordinary high water mark, which is a line defining the boundary between upland and bottomland. In 1974, the USACE offices around the Great Lakes agreed on an elevation of the OHWM for each lake based on consistent physical characteristics corresponding to historic water level data dating back to the 19th century. This line is used to govern the application of regulations under several statutes, including the Rivers and Harbors Act and the Federal Clean Water Act.

*Seiche*: a standing wave in an enclosed or partially enclosed body of water. Seiche related phenomena are observed on lakes, reservoirs, bays, and seas.

*Stringer*: a large, heavy horizontal timber which supports a floor or bridge deck.

*UP*: an acronym which stands for Upper Peninsula, referring to the upper peninsula of Michigan.

*USACE*: an abbreviation for the U.S. Army Corps of Engineers, which is a U.S. Department of Defense agency responsible for investigating, developing, and maintaining the nation's water and related environmental resources.

*USFS*: an abbreviation for the U.S. Forest Service, which is a U.S. Department of Agriculture agency responsible for managing public lands and resources in the national forests and grasslands.

*UWWaves*: a desktop computer software routine for calculating fetch; a component of ArcGIS, a group of geographic information system software products produced by the Environmental Systems Research Institute.

*Wind Rose*: graphic tool used by meteorologists to give a concise view of how wind speed and direction are distributed at a particular location. Presented in a circular format, the wind rose shows the frequency of winds blowing from particular directions.

*WRPLOT*: a Windows-based desktop computer program that generates wind rose statistics from meteorological data.

### Chapter Summary

This chapter has provided an introduction to the problem, its general setting, and the research objective and questions. It also outlined the study's major components, as well as the delimitations, assumptions, and limitations. The research study assessed all phases of crib dock site design, approval, and construction to develop a proposed a set of recognized standards, or norms, for crib docks that address environmental impact, public safety, and structural integrity. As stated above, the results will be provided to the appropriate agencies for consideration and codification of the crib dock approval process and will add to the existing knowledge about resolving multiple jurisdictional construction issues in the era of sustainable construction.

### Report Overview

The study report is organized into five chapters. This first chapter has provided an introduction to the study. Chapter Two explores existing literature related to the study, with the intent of further validating the assumptions and developing a more complete understanding of the background and current state of environmental and construction permit processing, crib dock design and environmental factors, and the research methodologies

considered and subsequently employed to study the problem. Chapter Three lays out the mixed methods exploratory research design and explains the primary research thrusts: the interviews with crib dock builders, the qualitative component, and the analysis of completed crib docks, the quantitative component. These primary efforts were reinforced by the secondary focus to explore the greater social and ecological context for non-standard construction permitting processes through interviews with appropriate government officials. Chapter Four presents the findings of the research and provides an analysis of those findings. A summary of this work, conclusions developed, and recommendations for further work are presented in Chapter Five.

## CHAPTER 2

### REVIEW OF RELATED LITERATURE

This chapter presents a review of literature related to the problem and then literature related to the research methodology and design. The initial discussion provides the historical, scholarly, and contextual background for the problem and its importance. It will also set the stage for the initial thoughts on research methodology options, which guides the subsequent discussion. The review of literature related to the research design addresses the mixed methods methodology, the Grounded Theory approach, and the Direct Measurement methodology. Taken together, the literature review provides a succinct summary of the key issues considered in the research design.

#### Literature Related to the Problem

This review addresses four aspects of the problem: building codes and permits, environmental and public health laws and associated permits, the environmental impact of crib docks, and the structural requirements for safe and sound crib docks. The initial discussion covers literature that addresses the purpose, development, and application of structural building codes and associated permit processing and focuses primarily on the deterministic approach used to ensure that the codes apply clearly defined structural and physical safety standards for proposed structures. This building code discussion is followed by a parallel review of literature and public law pertaining to the environmental and public safety aspects of built facilities. This discussion addresses both environmental and public health laws and building codes as they affect the built environment and associated

construction permit processing. The literature review then considers the variety of scholarly and legal literature that addresses the environmental effects of crib docks; their placement and size; and their effects on the lake bed, currents, water life, and vegetation. This is followed by a review of the limited available literature that addresses the structural design requirements for safe, sturdy, structurally sound crib docks.

### *Construction Codes & Permit Processes*

The primary rationale for residential building codes is to protect health and safety (Hammit, Belsky, Levy, & Graham, 1999, p. 1037). A building code is a set of rules that specify the minimum acceptable level of structural quality for buildings and other structures, such as docks. Building codes date from Laws of Hammurabi, a Mesopotamian ruler from 2285-2242 B.C. Hammurabi's code was a simple performance code:

Law §229. If a builder has built a house for a man and has not made strong his work, and the house he built has fallen, and he has caused the death of the owner of the house, that builder shall be put to death. (Johns, 1911, p. 48)

Clearly, this was a performance-based building code with a genuine incentive for the builder to meet the established standard. In the centuries that followed, building codes changed very little. In Western societies, the nobility ruled in a manner similar to Hammurabi, with death or dismemberment as likely consequences for transgressions of established structural standards (Francis & Stone, 1998, p. 1).

The Industrial Revolution, particularly as practiced in North America, brought with it changes in social order and administration of law. Concurrently, building construction practices were changing. However, certain construction practices were less than ideal with regard to safety of life and limb. The most common example was the textile industry of New

England. Tragic fires in textile mills of the late nineteenth century led to innovations such as sprinkler systems and multiple exits. It became clear that better regulation of the built environment was required. The new progressive social order demanded increased vigilance in protecting both property and life (Francis & Stone, 1998, p. 1). This social mandate led to the creation of the current building regulatory system in the United States. It is the product of four foundation efforts: the insurance industry, the tenement and housing movements, the engineering profession, and the construction industry (Listokin & Hattis, 2005, p. 24).

### *The Insurance Industry*

In the United States, building codes were initially introduced to minimize losses from fire and associated fire insurance claims. Following large fires in Boston, New York, Chicago, and Baltimore, in the late 1800s, the first comprehensive building codes were researched and developed by the fire insurance industry as a means of protecting the industry's viability (Lew, Bukowski, & Carino, 2005, p. 37). Subsequently, in 1893, the Western Underwriters Association hired William Merrill, an electrical engineer, to evaluate structural electrical problems. The laboratory later became the *Underwriters Laboratories* in 1896. Also in 1896, the National Fire Protection Association was formed and published their first two standards: one on automatic sprinklers, the *Standard for the Installation of Sprinklers*, and the second a consolidation of local electrical regulations into the first *National Electrical Code* (Solomon, 1994, p. 612). In 1905, the National Board of Fire Underwriters developed and published the *National Building Code*, the first model building code in the United States (Lew et al., 2005, p. 37). Throughout the 1900s and to this day, the



insurance industry has played an active role in evaluating and regulating building design and construction.

### *The Tenement and Housing Movements*

Tenement and housing movements of the 19th century brought to light the connection between public health and the built environment. They highlighted how increasingly crowded, unsanitary industrial cities were resulting in higher disease infection rates and reduced life expectancy. Mounting social pressure led to the installation of comprehensive sewer systems, improvements in building designs to ensure that residents received natural light and fresh air, and the relocation of residential areas away from noxious industrial facilities. These actions generated dramatic improvements in public health. As a result, laws were established that reflected the concern for housing reform by regulating health and sanitation, as well as the fire safety aspects of housing. The New York Tenement House Act of 1901 served as model legislation for many other cities. Tenement laws also were included in the 1905 National Building Code. Since 1939, the American Public Health Association has maintained a focus on housing standards and is credited with developing the prototype for modern housing codes, which include specific health and sanitation requirements (Perdue, Stone, & Gostin, 2003, p. 1290).

### *The Engineering Profession*

Civil and structural engineering provided the foundation for the structural requirements of building regulations. By the second half of the 19th century, structural analysis and design methods had been developed for analyzing structural materials and

designs. These methods were accepted by a consensus of the profession and incorporated into early city building codes including the 1905 National Building Code. Similarly, regional professional associations were establishing building codes: the Pacific Coast Building Officials Conference issued the *Uniform Building Code* in 1927; the Southern Building Code Congress published the *Southern Standard Building Code* in 1946; and the Building Officials and Code Administrators published the *Basic Building Code* in 1950. Until recently, one of these three regional model building codes provided the basis for state and local building codes nationwide. They were periodically updated to incorporate developments in materials, methods, and practices. In more recent years, engineering associations have been involved in developing a consensus standard for structural design, mechanical codes and standards, and plumbing codes and standards, which led to the *International Building Code* in 2000. As the name implies, this is an international model building code, the first of its kind (Lew et al., 2005, p. 37).

### *The Construction Industry*

The construction industry itself has always played an active role in setting building regulations, often as a way of furthering, and, at times, limiting, the use of certain materials and methods. One of the industry's strongest influences can be seen in plumbing codes. Plumbing codes developed early at the local level. The earliest on record is the 1870 code for the city of Washington, D.C. The National Association of Master Plumbers, since its organization in 1883, has been concerned with national codes versus the early regional plumbing codes designed in accordance with the local conditions and practices. However, the association did not publish a model plumbing code until 1933. The Plumbing, Heating,

and Cooling Contractors National Association, successor to the National Association of Master Plumbers, has published the National Standard Plumbing Code, used in many jurisdictions, since the 1970s. The National Association of Home Builders has also long been active in refining building codes that affect home construction and homeowner and apartment dweller access to high quality, secure, affordable shelter (Listokin & Hattis, 2005, p. 26).

### *Government Oversight and Enforcement In Michigan*

The regulation of building construction in the United States has evolved from multiple specific, voluntary codes to an exercise of government police power. With very few exceptions, this regulation is legislated and enforced at the state or local government level. It traditionally has been accomplished by a set of four interrelated codes: a building code, a plumbing code, a mechanical code, and an electrical code. Each addresses a specific building system or attribute. The building code addresses the building's structural system, fire safety, general safety, enclosure, interior environments, and materials; the plumbing code addresses the building's potable water supply and waste systems; the mechanical code addresses a building's combustion and mechanical equipment; and the electrical code addresses electrical power supply, distribution, and use (Ghosh, 2002, p. 134).

Local governments in Michigan historically had the option to adopt and enforce any nationally recognized model building code (Syal & Shay, 2001, p. 1). In 1999, Michigan amended the process of code adoption under the State Construction Code Act (Act 230). This act now requires municipalities to administer and enforce formally adopted statewide codes, including the International Building Code, International Plumbing Code, International

Mechanical Code, and International Residential Building Code developed by the International Code Council (ICC), and the National Electric Code published by the National Fire Protection Association. The language allows local communities to supplement the state codes, but not modify or eliminate requirements. For residential construction, these codes have been consolidated into the Michigan Residential Code, which is the 2003 version of the International Building Code with limited state mandated additions (MDLEG, 2003, Inside Front Cover).

Application for and approval of a construction permit in the state of Michigan is handled by the local government, either city or township. Permits are required for new construction of any new freestanding structure of greater than 200 square feet or significant renovations to an existing structure. The Building Permit Application identifies the project, the owner, who designed the project, and who will build it. The application also includes a complete listing of how environmental controls will be met and a detailed site plan. The site plan is used to ensure the proposed structure meets local zoning, lot size, and set-back requirements (MDLEG, 2007). Once the permit is approved and issued, it is the owner's responsibility to ensure that all necessary site inspections and approvals are obtained during the course of construction. The local government is responsible for the enforcement of the Michigan Building Code and Michigan Mechanical Code, while the state is responsible for the enforcement of the Michigan Plumbing Code and the Michigan Electrical Code (Guide to Residential Construction, Sault Ste Marie, 2007, p. 3). All inspections are based on the standards established in the Michigan Residential Code (MDLEG, 2003).

### *Environmental Laws & Permit Processes*

The beginnings of formal environmental regulatory policies that affect the built environment can be seen during the progressive era of the late 1800s when American environmental policy emerged from two distinct public forces. The first was the growing public health need to protect people from urban environmental causes of death and disease, a result of the increasingly large scale urbanized industrial regions. The second developed from natural resource protection and preservation traditions that demanded restraints on the free market's destructive effects on the natural resources and landscapes (Andrews, 1999, p. 109).

#### *Public Health Movement*

As discussed earlier, the tenement and housing movements of the mid-19th century brought to light the connection between public health and the built environment. The nation's transformation from widely scattered towns and villages to large urban industrial regions resulted in a need for government action to protect people from the effects of highly concentrated populations. This led numerous government commissions to study the problems and make recommendations, notably *The Sanitary Condition of the Laboring Population of New York* in 1845 and the *1850 Report of the Massachusetts Sanitary Commission*. These surveys, and others like them, consistently recommended building municipal water and sewer systems, improving street cleaning and garbage collection programs, creating stronger local health departments, and passing more effective sanitary laws. The recommended sanitary laws included tenement building codes to ensure that residents received sufficient fresh air and sunlight, plumbing codes and associated public

sewers to ensure that human waste was removed and properly treated, fire codes to ensure adequate emergency exit pathways, and electrical codes to minimize electrical fire hazards (Andrews, 1999, p. 114). These early public health related environmental regulations drew their authority from government's power to assure public health and safety. This authority was validated by the Supreme Court in 1824, in the case *Gibbons v. Ogden*, which challenged a local government's authority to impose quarantine (Andrews, 1999, p. 113).

### *Environmental Protection*

Concurrent with the growing public health movement was a growing concern over pollution, primarily of air and water. In the late 1800s, air pollution was apparent in many of the major industrial areas, and its detrimental affect on local inhabitants was well documented. However, air pollution had strong industrial backing, because it was felt to be simply characteristic of a healthy economy. Similarly, water pollution, while not as readily apparent, was just as significant a risk. Until well into the early 1900s, dumping sewage and industrial waste in natural waterways was considered acceptable given adequate dilution. Pollution was also considered by industry and the courts as an "unavoidable byproduct" of economic progress. Public pressure to control air and water pollution did rise to some degree over time, which was addressed by state and local regulation. By 1912, twenty-three of the country's 28 largest cities had some form of smoke abatement ordinance. Unfortunately, the government authority and public will to enforce these ordinances proved weak and ineffective. In short, there was little legislation or enforcement of industrial pollution controls prior to the 1960s (Andrews, 1999, p. 128).

While not apparent at the time, the first significant national environmental pollution control legislation was the Rivers and Harbors Appropriation Act of 1899. The act drew its mandate from the federal government's constitutional role of facilitating interstate commerce. Section 10 of the Rivers and Harbors Act states:

That the creation of any obstruction not affirmatively authorized by Congress, to the navigable capacity of any of the waters of the United States is hereby prohibited; and it shall not be lawful to build or commence the building of any wharf, pier, dolphin, boom, weir, breakwater, bulkhead, jetty, or other structures in any port, roadstead, haven, harbor, canal, navigable river, or other water of the United States, outside established harbor lines, or where no harbor lines have been established, except on plans recommended by the Chief of Engineers (Rivers & Harbors Appropriation Act, 1899).

In other words, the act made it illegal to impede interstate commerce by placing an obstruction in an interstate waterway without proper authority. The act assigned the review and approval authority for such application to the Corps of Engineers. It is this responsibility that gives the Corps approval authority for crib dock construction permit applications, since when they are placed in the Great Lakes they could be an obstacle to interstate commerce. In addition to this role, the act's Section 13 goes on to say:

That it shall not be lawful to throw, discharge, or deposit, or cause, suffer, or procure to be thrown, discharged, or deposited either from or out of any ship, barge, or other floating craft of any kind, or from the shore, wharf, manufacturing establishment, or mill of any kind, and refuse matter of any kind or description whatever other than that flowing from streets and sewers and passing there from in a liquid state, into any navigable water of the United States (Rivers & Harbors Appropriation Act, 1899).

The section, commonly known as the Refuse Act, made it a misdemeanor to discharge refuse matter of any kind into the navigable waters of the United States without a permit. Up until the growing environmental movement of the late 1960s and the Clean Water Act of 1972, the Rivers and Harbors Act was the only definitive, enforceable federal water pollution control legislation. (EPA History Office, 1972; Rivers & Harbors Appropriation Act, 1899)

### *National Environmental Policy Act of 1969*

The late 1960s produced strong public opinion that the government should take the lead in curbing pollution and rolling back environmental destruction. Correcting the problems at hand would require a change in the federal government's own policies and actions. Coordination of the multiple agencies involved was required in order for the policies to work properly. They needed to work together in pursuit of common objectives. The National Environmental Policy Act (NEPA), signed by President Nixon in 1970, provided this coordination and established a clear environmental mandate for decades to come. The NEPA consisted of three major elements: a statement of national policy, a clear set of action elements including the environmental impact statement (EIS), and the Council on Environmental Quality (CEQ). While the policy component was largely viewed as rhetoric and the CEQ held no authority, the action elements, in particular the EIS, provided an effective set of meaningful tools for addressing environmental priorities. The NEPA set the stage for a number of key follow-on pieces of legislation, notably the National Land Use Policy Act, the Coastal Zone Management Act, and the Federal Water Pollution Control Act, which included section 404 addressing wetlands protection (Andrews, 1999, p. 285).

### *Michigan Natural Resources Environmental Protection Act of 1994*

The State of Michigan's role in the NEPA and associated legislation was set out in the Michigan Natural Resources Environmental Protection Act of 1994 (NREPA). The NREPA addressed shared natural resources like air and water; set minimum standards for environmental protection; and detailed state responsibilities to protect the air, water, and land from pollution, impairment, or destruction. The act also defined the role of local



governments in pollution source management, which is for the most part voluntary. A number of key parts of the NREPA are pertinent to crib dock construction permitting: Part 303 - Wetlands Protection; Part 323 - Shorelands Protection and Management; and Part 325 - Great Lakes Submerged Lands (Ardizone & Wyckoff, 2003, p. I-14).

Michigan's wetland statute, NREPA Part 303 - Wetlands Protection, defines a wetland as "land characterized by the presence of water at a frequency and duration sufficient to support, and under normal circumstances does support, wetland vegetation or aquatic life, and is commonly referred to as a bog, swamp, or marsh." The definition applies to public and private lands regardless of zoning or ownership. Most people are familiar with the cattail or lily pad wetlands found in areas with standing water, but wetlands can also be grassy meadows, shrubby fields, or mature forests. Many wetland areas have only a high groundwater table; standing water may not be visible. Types of wetlands include deciduous swamps, wet meadows, emergent marshes, conifer swamps, wet prairies, shrub-scrub swamps, fens, and bogs (NREPA, Part-303, 1994). Typically a regulated wetland in Michigan is one contiguous to the Great Lakes, an inland lake, or stream, or an area of five acres or more in size. Wetland conservation is a matter of state concern; therefore, any construction in or near a wetland must be fully reviewed and approved by the Michigan Department of Environmental Quality (MDEQ) and by the U.S. Army Corps of Engineers (USACE) using the USACE-MDEQ Joint Application Permit Process (MDEQ, 2006, p. 1-2).

Part 323 of the NREPA, Shorelands Protection and Management, provides consumer protection from the natural hazards of coastal erosion and flooding, as well as environmental protection of fragile coastal areas. Part 323 addresses land that borders, or is adjacent to, a Great Lake or a connecting waterway and is within 1,000 feet of the ordinary high water

mark (NREPA, Part-323, 1994). The ordinary high water mark (OHWM) is the long term average shoreline high water mark. It defines the geographic and jurisdictional limits of rivers and lakes for the regulatory powers of government; for the Great Lakes the Corps sets the OHWM based on 1985 lake levels. The protected environmental areas are defined by the statute as “an area of the shoreland determined by the Department [of Environmental Quality] on the basis of studies and surveys, to be necessary for the preservation and maintenance of fish and wildlife.” While rather rare designations, the entire Les Cheneaux and Drummond Island coastal zones are protected environmental areas (Ardizzone & Wyckoff, 2003, p. II-9). As with Part 303, any construction within a Great Lakes shorelands area, as defined by Part 323, must be fully reviewed and approved by the MDEQ and the USACE using the USACE-MDEQ Joint Application Permit Process (MDEQ, 2006, p. 1-4).

Part 325 of the NREPA addresses Great Lakes Submerged Lands. Michigan’s Submerged Lands Program is responsible for regulating construction activities along the 3,165 miles of Great lakes shoreline and over 38,000 square miles of Great Lakes bottomlands, including coastal marshes. Bottomland is defined as lake bottom of all the Great Lakes, to include bays and harbors, lying below and lakeward of the natural ordinary high water mark. The State of Michigan is trustee of the bottomlands and waters of the Great Lakes and has a perpetual duty to manage these resources for the benefit of the citizenry (NREPA, Part-325, 1994). As with Parts 303 and 323, any construction project that will be ultimately placed and remain on Great Lakes bottomlands must be fully reviewed and approved by the MDEQ and the USACE using the USACE-MDEQ Joint Application Permit Process (MDEQ, 2006, p. 1-2).

### *Government Oversight and Enforcement In Michigan*

Responsibility for the oversight and enforcement of laws pertaining to Michigan's natural resources is shared by two state executive departments: the Michigan Department of Natural Resources (MDNR) and the Michigan Department of Environmental Quality (MDEQ). The MDNR was originally established in 1921 as the Michigan Department of Conservation. It was responsible for the stewardship of Michigan's natural resources and for the provision of outdoor recreational opportunities. In 1995, Governor John Engler separated the environmental and natural resources functions into two departments, elevating environmental protection to cabinet level status. The Department of Environmental Quality focused on environmental regulatory, permitting, and related enforcement functions, while the MDNR focused on promoting diverse outdoor recreational opportunities, wildlife and fisheries management, forest management, state lands and minerals, state parks and recreation areas, and conservation law enforcement (MDNR, 2007). As a result, the MDNR is responsible for maintenance and enhancement of water and wildlife habitat, while the MDEQ is responsible for enforcing the Michigan NREPA to include, the USACE-MDEQ Joint Application Permit Process.

The USACE-MDEQ Joint Application Permit Process was developed to facilitate the state and federal permit application process for regulated activities where the land meets water. The process uses one combined form that provides the information both agencies require to review and approve a proposed action. The form consists of 21 sections; Sections 1 to 9 must be completed by all applicants. Sections 10 through 20 apply to specific project types, only the sections that pertain to a proposed project must be filled out; Section 10 for a boat dock. Since the Les Cheneaux and Drummond Island shore lands are designated as

protected environmental areas, Section 21 must also be completed. The application must include a project drawing like the sample provided in Figure 4. The completed application is mailed to the MDEQ Land and Water Management Division. The administrative review is projected to take 15 to 30 days, while the technical review is projected to take 60 to 90 days. While the duration of the review and approval process is clearly delineated, the standards upon which approval will be based are not. Once the MDEQ has rendered a decision, the application is forwarded to the USACE district office in Detroit for their review and approval. Nowhere in the manual is the basis for approval discussed (MDEQ, 2006, p. 2-26).

### *Environmental Effects of Crib Docks*

There is some related scholarly research on how shoreline development and crib-based structures affect littoral water life and water quality. The associated government literature is quite limited. The scholarly research is sporadic over the past twenty years, consisting primarily of water life and environmental impact assessments. The topics of particular interest to this research are the positive effects crib structures have on freshwater life habitat and the negative effects of crib structures on the lake bottom and littoral flow.

### *Positive Effects of Crib Structures On Water Life*

In 1994, Beauchamp, Byron, and Wurtsbaugh used scuba observations to determine the summer habitat use by littoral-zone fish in Lake Tahoe, California-Nevada. The littoral zone is the near shore portion of a lake's surface waters that extends from the ordinary highwater mark to the point where the well-mixed warm surface waters reach the lake bed during the summer months (Horne & Goldman, 1994, p. 17). Of particular interest, they

**Sample Drawing 10**

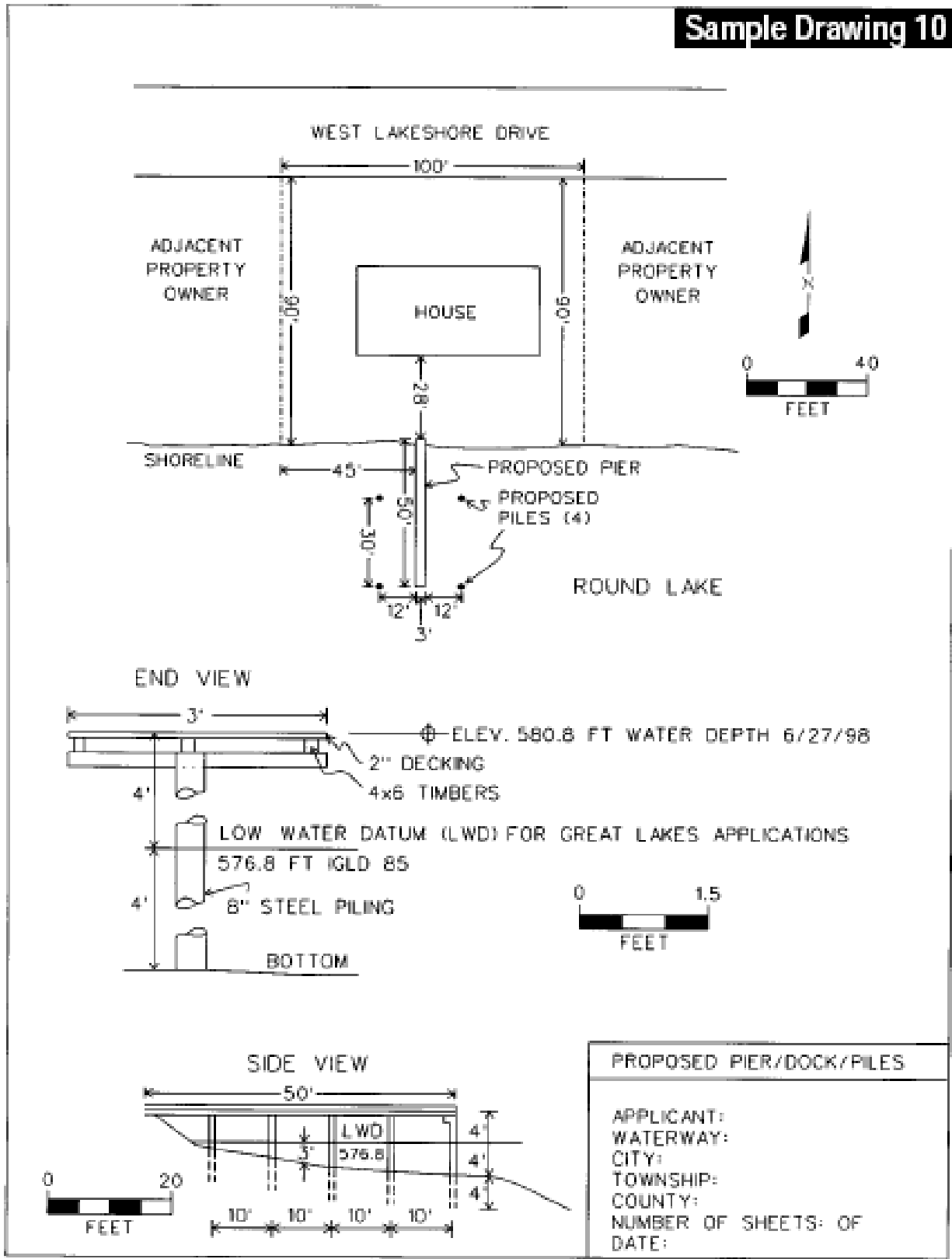

Figure 4. Sample Drawing for Proposed Pier, Docks, & Piles (MDEQ, 2006, p. B-6).

examined the effects of shore-zone structures, primarily docks, on fish density using a series of paired comparisons between fish densities associated with structures and densities in adjacent areas with a similar underlying substrate, but without structures. The two common style docks in Lake Tahoe were either supported by pilings or timber crib piers. The piling docks consisted of 20-30 cm diameter steel or wood pilings, sunk into the substrate at approximately 5 m intervals, with solid decking. The piling-supported docks provided simple submerged structures, which lacked habitat complexity and had a defined shadow zone. In contrast, the crib docks provided habitat complexity in all three dimensions. The investigators found that cribs were the only shoreline structures that had any significant effect on fish densities. In fact, fish densities were many times higher than that of paired no-crib areas. “Both daytime and nighttime densities of Lahontan Redsides, Tui Chubs, juvenile Tahoe Suckers, and Speckled Dace were significantly higher around cribs than in the [piling dock], and no [dock] areas.” (Beauchamp, Byron, & Wurtsbaugh, 1994, p. 390)

Similarly, in 1996, Brown studied how shoreline residential development and physical habitat influences fish density in the shore zone areas of Lake Joseph, Ontario. Fish densities were obtained by establishing 60 transects. Each transect was 30 m long and ran from the ordinary high water-mark out 2.5 m. Each transect was inventoried four times, at weekly intervals, from July 8 to August 12, 1996. She found a significant positive correlation between forage fish density and complex woody debris. This suggested that the attraction of or protection by physical structure strongly influences forage fish densities. The complexity provides small interstitial spaces that act as refuge areas from predation, as well as greater surface area available to support food organisms. Complex woody debris was the only variable that correlated with the observed differences in forage fish density. Brown also

found that, in the absence of natural complex woody debris, crib docks were the best manmade structure for encouraging forage fish to thrive. In her discussion, Brown highlights that “In central Ontario there is a trend away from the construction of crib structures and towards the construction of pillar or pylon structures. Provincial policy does not require a building permit for construction of a pillar structure, but does require a permit for a crib foundation with a foundation footprint greater than 15 m<sup>2</sup>” (Brown, 1998, p. 21).

In 2004, the National Park Service conducted a detailed analysis to determine the optimum construction style to replace the docks in Tobin Harbor of Isle Royale National Park, in Lake Superior. The docks provide temporary moorage for pleasure craft visiting the park. The existing docks were damaged from long term exposure to winter ice loading. The analysis of replacement alternatives considered endangered species and their habitats, water quality in Tobin Harbor, public health and safety, and the visual impact by the replacement docks on the visitor experience. The alternatives considered included 1) not replacing the docks, 2) replacing the docks with one of two crib dock options, or 3) replacing them with one of two binwall dock designs. The binwall dock designs consisted of sheet piling enclosed piers. After completing the detailed structural analysis and environmental impact assessment, one of the crib dock options was the preferred alternative. It was determined that the crib dock options were most effective at meeting the structural criteria, protecting the sensitive environment, and contributing to the historic nature of the Tobin Harbor area (IRNP, 2004).

In 1994, Charles Bassett of the USDA’s Forest Service (USFS) conducted an analysis of fish habitat structures used in lakes of the USFS Eastern Region during 1978 to 1991. The USFS Eastern Region comprises 14 national forests in 11 northeastern and midwestern

states. In that timeframe, over 4,290 fish habitat structures were installed in approximately 130 Eastern Region lakes. National forests in Michigan, Wisconsin, and Minnesota accounted for about 86% of the structures. Structures were installed to meet at least one of the following objectives: 1) increase production of fish and forage organisms by increasing habitat diversity in lakes where aquatic vegetation, woody debris, or other natural structure was scarce; 2) concentrate fish to facilitate harvest by anglers; and 3) provide spawning habitat for a particular species of fish. Brush piles and log cribs were the two most popular methods of providing offshore woody debris in lakes. Fish population responses to structures were evaluated by counting fish near structures or by determining lake-wide population changes. Brush piles, log cribs, tree drops, and Christmas trees held more fish and provided better fishing than adjacent unmodified habitat. However, none of the evaluations demonstrated that woody structures increased lake-wide production. Biologists experimented with various designs and placement schemes for log cribs, but the only variables that consistently affected fish use were water depth and amount of brush fill (Bassett, 1994).

During February of 2003, 2004, and 2005, volunteers from the Straits Area Sportsmen's Club and the Brevort Lake Development Association built, loaded with ballast, and positioned log cribs on the surface of frozen Brevort Lake, near St. Ignace, Michigan. Twenty were placed each year so that during the spring thaw they would sink to the bottom and provide fish habitat. The sites were selected to allow at least ten feet of clear water above the sunken cribs in areas where the lake bottom or substrate was hard packed with sparse vegetation. Their efforts were praised by U.S. Forest Service's Fisheries Biologist, Jon Reattoir from Sault Ste. Marie (Gringras, 2005). In July 2006, Michigan State Police



divers conducted dive training in Brevort Lake to check on the results. They confirmed that the cribs had provided significant amounts of attractive fish habitat. According to one of the divers “We saw a lot of fish. The cribs are providing plenty of habitat [for fish] to congregate in. We saw hundreds of perch in each structure.” According to the article, the goal was to ultimately install 200 cribs in Brevort Lake solely to improve fish habitat and sport fish population (Gringras, 2006).

And finally, the Australian Queensland Government Department of Primary Industries and Fisheries bulletin Fisheries Guidelines for Fish-Friendly Structures is intended to “...encourage consideration of, and provide guidance for, the planning, design, construction, and operation of aquatic infrastructure that it is *fish friendly*.” The bulletin considers fish friendly structures those that 1) cause minimal disturbance to the existing environment and 2) incorporate design features that provide and enhance habitat in which fish can live. It further points out that incorporation of fish-friendly elements into the design of structures can help to provide a balance between urban development and maintenance, or enhancement, of the productive capacity of fish habitat. To that end, the Queensland freshwater biologists bulletin reviewed and evaluated much of the same literature related to crib docks covered earlier. They found that while crib docks do smother substrate, unlike pylon supported docks, they provide substantial additional habitat for biota and enhance the density and diversity of fish populations. (Derbyshire, 2006, p. 19)

#### *Negative Effects of Lake Bottom Consolidation and Hindering Littoral Flow.*

Throughout the literature search, statements such as “From an environmental perspective, cribs aren’t the most destructive kind of dock. But because a crib covers a large

area of submerged ground, essentially smothering anything beneath it, crib based docks often claim a close second on the list of bad-guy installations” (Burns, 2004, p. 17) and “Since 1988, new dock constructions have shifted from crib-style to less habitat-destructive types such as post docks, floating docks and cantilever docks” (McNeill & Promaine, 2007, p. 5). However, follow-up contact with these authors was fruitless in attempting to find any research that validated these statements. A parallel search for any governmental documentation to justify these statements was also unsuccessful.

However, based on the inferences, the primary concern is the docks’ impact on littoral zone ecosystem and flows. Water life diversity, density, and productivity are high in the littoral zone. Most types of insects, snails, worms, crustaceans, and fish occur in these shallow, well-mixed waters. The organisms that live in this zone must be able to tolerate strong wave action, and most are firmly attached to rocks and plants. The littoral flow is a mild current that runs roughly parallel to the ordinary high water mark (Horne & Goldman, 1994, p. 292). The cribs do interfere with the littoral zone ecosystem and flow; however, the extent is unclear. Therefore, this topic needed to be addressed with the MDEQ during the qualitative research phase.

#### *Crib Dock Siting & Design Considerations*

This portion of the review considered literature that covers the structural design, material composition, and construction of crib docks. There is general material on the code and material information related to crib dock construction, but the crib dock specific literature is limited to two authorities: Max Burns, a writer and outdoorsman from central Ontario, and C. Allen Wortley, an emeritus faculty member from the University of

Wisconsin at Madison, who specializes in cold regions small craft harbors. The discussion will address the environmental considerations, that is rot, ice, and wind; the structural considerations; and building code considerations.

*Environmental Considerations: Rot, Ice, Wind*

The U.S. Forest Service, in their “Technical Bulletin - Floating Trail Bridges and Docks,” discusses the use of crib docks in natural settings. It observes that crib docks should be constructed of durable wood such as Douglas fir, larch, or hemlock. They state that cribs built in this way, continually submerged in water, can last 50 years or longer without treatment (Neese, Eriksson, & Vachowski, 2002, p. 11). This point is substantiated by the Detour and Martin reef crib supported lighthouses built by the U.S. Coast Guard’s Lighthouse Service in the 1920s and still in use in the research area today. The crib under the Detour lighthouse has been inspected by underwater cameras and found to be completely sound.

Over a period of 80 years, the U.S. Department of Agriculture (USDA) Forest Products Laboratory ran continuous comparison tests of wood preservatives in driven stake tests. The test results are primarily for Southern Pine 2”x4”x 18”, untreated, surface treated, and pressure treated, set nine inches deep in soil. The test sites were Saucier, Mississippi; Madison, Wisconsin; Bogalusa, Louisiana; Lake Charles, Louisiana; Jacksonville, Florida; and the Canal Zone, Panama. The tests were initiated in 1938 and the stakes periodically removed, inspected, and reinserted unless their condition warranted removal. The results for the Madison, Wisconsin, site found that untreated Southern Pine stakes will last 4 to 6 years, but the pressure-treated stakes have not yet begun to deteriorate to any significant extent

(Crawford, 2000, p. 4). The waterborne pressure treatment used in the stake tests was chromated copper arsenate (CCA), which the EPA no allows to be used for freshwater applications. However, the treatments now approved by the EPA for freshwater application, alkaline copper quat (ACQ), have been found to be equally as effective as the CCA treated wood (Lebow, 2007, p. 52).

Burns, in “The Dock Manual (1999),” points out that a crib’s principle nemesis is ice. As the water in and around the crib freezes, it gets a firm hold on the crib. When water levels under the ice change, typically in response to seiche, the ice pulls on the crib. If the water level rises, the ice can actually lift the entire crib, rocks and all. If the crib has been properly built with a floor capable of holding the weight of the rocks, and the crib is well secured to shore, it will usually lower back down, intact, as the ice melts or the water level drops. If the water level drops, the crib must be able to carry the weight of the ice clinging to it without breaking or capsizing (Burns, 1999, p. 54).

Wortley analyzed the design criteria and structural design for pilings, piers, and docks subject to ice loading in the upper Great Lakes. His work, reviewed by the Technical Council on Cold Regions Engineering, found that gravity-type crib structures will experience ice induced lateral loading, but the thickness of the ice is not a linear factor in estimating thermal forces. Thin ice will simply buckle before exerting significant force, while thick tends to be self-insulating attenuating temperature swings. Significant wind exposure in combination with moderate ice thickness presents the greatest threat. For these reasons, Wortley recommends a design value of 10 kips/ft for thermal thrust on gravity type crib structures. (A kip is a kilo-pound or 1000 pounds of force; Muvdi, Al-Khafaji, & McNabb, 1996, p. 32). Values of one-half as much would be appropriate in areas with large snowfalls

or weak unsound ice. At the other extreme, 20 kips/ft is an appropriate estimate for clear ice, in a confined boat harbor, with defined banks (Wortley, 1982, p. 205). Similar recommendations are made in the American Society of Civil Engineers' manual "Planning and Design of Small Craft Harbors" (ASCE, 1994, p. 223).

### *Structural Considerations*

Burns, in "The Dock Primer (2004)," an Ontario Ministry of Fisheries and Oceans publication, states that dock cribs should be made from new 6-8 inch square-cut timbers of hemlock, Douglas fir, or a comparably strong, decay resistant species. The timbers should be assembled in opposing pairs, one pair laid on top of the next, creating a slatted box with an integral floor. Intermediate ties can be added to reinforce the unitary structure of the crib. The corners should be bolted together using galvanized threaded rod run the full height of each corner to secure the timbers in place. He also recommends angling the cribs so they face into the prevailing winds. This minimizes the ice loading on the corners, which are the weakest part of the crib. Finally, the cribs should be filled with sufficient rock ballast to withstand weathering and ice loads. The ballast should be obtained from off-site to minimize disturbing local water life habitat. The maximum depth for a crib is about eight feet. For optimum stability, cribs should be square with the width and length equal to or greater than their height. As for the deck superstructure, Burns recommends the stringers or joists be evenly spaced on 24" centers for nominal 2" decking and 16" centers for 5/4" decking (Burns, 1999, p. 54 & 87, 2004, p. 16).

### *Policy Considerations*

Crib docks are typically given little specific attention in waterfront ordinances or regulations; none was found for any Michigan government entities. However, three examples of crib dock specific ordinances from other locations were found that provide some insight to standards that could be used in considering an application to site and build a crib dock structure. Beyond this, there are some elements of the USACE federal code and the Michigan Residential Code that are applicable to dock construction.

The Canadian Department of Fisheries and Oceans (DFO), 2005, “Habitat Management Program Operational Statement for Ontario” recognizes that docks and boathouses are common features on the shorelines of lakes and rivers and an important waterway recreational feature. It further recognizes that these littoral areas provide important habitat for a variety of aquatic organisms, including fish. The operational statement lays out the measures that must be incorporated into the design and construction or repair of docks and boathouses so as to avoid negative impact on fish habitat and in order to proceed without formal DFO approval. The operational statement allows crib docks that are built entirely on natural bedrock or sand bottom with a total combined footprint, for both existing and proposed cribs, of not more than 15 m<sup>2</sup> [161 ft<sup>2</sup>] to be built without formal review or approval (CDFO, 2005, p. 2). Similar statements were found in the Manitoba and Maritime Provinces versions of the same publication.

In Montana, the 2002 Flathead County Lake and Lakeshore Protection Regulations are intended to “...protect the fragile, pristine character of Flathead County’s lakes and recognize that the ecosystem of these lakes are [sic] inseparably intertwined with the adjacent riparian corridor and uplands area.” To that end, the regulations require that crib dock

designs and site plans allow eight feet of littoral flow area between the ordinary high water line lakeward to the first crib pier. It further states that the ballast or fill for the cribs shall be obtained off site, at least four inches in diameter, and consist of clean rock, free of sand, silt, and clay (Lake and Lakeshore Protection Regulations, Flathead County, MT, 2002, p. 22). Similarly, the State of New York requires that at least forty percent of a crib dock's running length must be open underneath to allow for littoral flow (New York State, 2002, Appendix A, p. 5.00).

The USACE Code of Federal Regulations (CFR) Title 33 and 36 as applied to recreational bodies of water states that all dock ramps and walkways shall be constructed of treaded metal, lumber treated with environmentally suitable chemicals, or marine products with skid resistant surfaces. It goes on to direct that walkways shall be at least four feet but not more than six feet; that walkways four feet above water or ground surface must have handrails 36 to 48 inches high with an intermediate guardrail approximately one-half the distance below the top rail; all convenience receptacles and lighting will have ground fault protection; and a light fixtures will be shielded or otherwise constructed so that residents or boaters are not blinded by the glare from the lights (USACE Mobile District, 2004, pp. 14-17).

While the Michigan Residential Code does not specifically address boat docks, it does provide standards for residential patio decks, which are structurally and functionally similar to dock decks. Table 1 below is an extract of the code's Table 502.3.1(2) for joists used in residential flooring taken from the Ann Arbor Municipal Code as it applies to residential patio decks. It shows that 2 inch joists can range from 2"x 6" to 2"x 12" over

spans ranging from 8 to 18 feet (Residential Building Code, City of Ann Arbor, 2004; MDLEG, 2003, p. 90).

Table 1

*Deck Joist Spans for Common Lumber.*

<b>Joist Size</b>	<b>Greatest Span when set on 24" Centers</b>	<b>Greatest Span when set on 16" Centers</b>
2 X 6	8' - 1"	9' - 4 "
2 X 8	10' - 3"	12' - 3"
2 X 10	12' - 7"	15' - 5"
2 X 12	14' - 7"	17' - 10"

#### Literature Related to the Research Design

Chapter 1, The Introduction, stated that this study used a two-phased, mixed methods research design. Given the nature of the problem and the limited available literature related to the problem, the study used a mixed methods sequential exploratory strategy, using Grounded Theory in the initial qualitative phase and Direct Measurement in the subsequent quantitative phase. Mixed methods employs a pragmatic approach to research, wherein the design is not committed to any one system or philosophy. Rather, the inquirers draw liberally from both quantitative and qualitative assumptions in their research. Thus, in mixed methods research, investigators use both quantitative and qualitative data, because they provide the best understanding of a research problem being pursued (Creswell, 2003, p. 12).

#### *Recent History of Mixed Methods Research*

Creswell and Plano Clark (2007) state that mixed methods research started with researchers and methodologists who believed that both qualitative and quantitative



viewpoints and methods were useful as they addressed their research questions. The formative period for mixed methods research began in the 1950s when Campbell and Fiske (1959) advocated for the collection of multiple forms of quantitative data to study the validation of psychological traits (Campbell & Fisk, 1959). In the early years, mixed methods research was called “multitrait/multimethod research” since it used multiple methods in the same project; “integrated” or “combined” in that it blended two forms of data together; “methodological triangulation,” recognizing the convergence of quantitative and qualitative data; and “quantitative and qualitative methods,” acknowledging that it is a combination of the two methods. Today it is known primarily as mixed methods research. As the process matured during the 1970s and 80s, many researchers were adamant that different assumptions provided the foundation for quantitative and qualitative research, which led to an intense paradigm debate. The paradigm debate was whether or not qualitative and quantitative data could be combined. To a great extent, the debate continues today with *purists* who contend that the paradigms should not be mixed, the *situationalists* who adapt their methods to the situation, and *pragmatists* who believe multiple paradigms can be used to address research problems (Creswell & Plano Clark, 2007).

Since the early 1990s, mixed methods has increasingly become recognized as a third major research paradigm, along with quantitative and qualitative research, positioning mixed methods research between the two philosophical extremes. Although not entirely new, it is a relatively new approach that has arisen in response to the shortcomings of quantitative and qualitative research. Mixed methods research is a synthesis that includes ideas from both paradigms. It allows for the convergence of findings from two or more methods, which “enhances our beliefs that the results are valid and not a methodological artifact.” By using

mixed methods, the bias inherent in a data source, investigator, or methodology will be canceled out when used in conjunction with data from other sources. In other words, once a proposition has been confirmed by two or more independent measurement processes, the uncertainty of its interpretation is greatly reduced. At the design stage, qualitative data can assist the quantitative component of a study by helping with conceptual and instrument development. During the data analysis stage, qualitative data can play an important role by interpreting, clarifying, describing and validating quantitative results (Johnson, Onwuegbuzie, & Turner, 2007).

#### *Mixed Methods Advantages and Challenges*

The key advantage of mixed methods is maximizing the strengths of each perspective while minimizing their inherent weaknesses. The primary characteristics of traditional quantitative research are deduction, statistical analysis, and theory or hypothesis testing. However, the methodology is handicapped by limited ability to place results in context or look into the full import of results and their meaning. Conversely, qualitative research is typically associated with induction, discovery, exploration, and theory generation. The data are typically gathered in the natural setting, tend to be process oriented, and are in the form of words or pictures rather than numbers. The results can be rich but are limited by the lack of statistical underpinning and associated projectability (Fraenkel & Wallen, 2003; Johnson & Onwuegbuzie, 2004). However, when the two are used in a mixed methodology, they can reinforce each other by using their strengths to address the other methodology's shortcomings. For instance, qualitative data collection following a survey can explain complex or contradictory responses, thereby avoiding inaccurate conclusions. This is

particularly useful for exploring outlier data to determine if there is a valid cause for it. This mixed methodological confirmation is *between-methods* triangulation, which can be done simultaneously or sequentially. Simultaneous triangulation is the parallel, concurrent use of qualitative and quantitative methods in which there is a limited interaction between the two sources, whereas sequential triangulation is utilized when the results of one approach are necessary for planning the next method. In either case, significant disagreement between the two sets of results is a signal to revisit the central research questions (Johnson et al., 2007, p. 114).

On the other hand, mixed methods research designs also have some inherent challenges that must be addressed to assure validity of results. First and foremost, mixed methods research designs are more complex and take longer to complete. They typically include two or more instruments that have to be designed and tested, as well as two or more data collections, reductions, and analyses. In addition, the researcher must be competent in both the quantitative and qualitative forms of research and conscious of their roles in the design execution (Creswell, 2003, p. 210). This is particularly an issue for researchers more experienced or comfortable with one form or the other. They need to be very careful not to unconsciously allow one set of results to overshadow the other set unless it is by design (Driscoll, Appiah-Yeboah, Salib, & Rupert, 2007, p. 25).

### *Mixed Method Designs*

When designing a mixed methods research strategy, four basic questions must be addressed: 1) what is the implementation sequence of the quantitative and qualitative data collection in the proposed study; 2) what priority will be given to the quantitative and

qualitative data collection and analysis; 3) at what stage in the research project will the quantitative and qualitative data and findings be integrated; and 4) will an overall theoretical perspective (e.g. gender, race/ethnicity, lifestyle, class) be used in the study (Creswell, 2003, p. 211)?

The results of this research strategy analysis will lead to one of six basic mixed method research strategies: sequential explanatory, sequential exploratory, sequential transformative, concurrent triangulation, concurrent nested, and concurrent transformative strategy. The sequential explanatory strategy consists of quantitative data collection and analysis followed by qualitative data collection to further explain or clarify the previous findings. The sequential exploratory strategy is also conducted in two phases. The qualitative phase is conducted first to develop an understanding of the research problem, while the subsequent quantitative phase is intended to validate and refine the previous findings. The findings in this strategy are integrated during the interpretation phase, and its primary purpose is to explore and develop understanding of relatively new issues or topics. The sequential transformative strategy is conducted much like the first two except that the sequencing is a researcher choice and a specific theoretical perspective is used, e.g. gender, race, ethnicity, life style, profession, and so on. In the concurrent triangulation strategy, the two data collections are conducted concurrently in an attempt to confirm or cross-validate findings in the process. Like concurrent triangulation, the concurrent nested strategy uses one data collection phase for both methods. However, one of the methodologies is nested, or designed to fit within, the construct of the other. Finally, the concurrent transformative strategy uses a concurrent data collection plan developed with a specific theoretical

perspective. Clearly, just from this quick summary of the basic mixed methods strategies, there is a distinctly greater level of complexity in the research design.

Given the nature of this research problem and the limited available literature related to the problem, this study called for a sequential exploratory strategy. A schematic for the general design of a sequential exploratory design is shown in Figure 5. The capitalized *QUAL* indicates that Creswell recommends that priority be given to the qualitative phase in the exploratory model. For this research, the qualitative phase was conducted using a Grounded Theory approach. The subsequent quantitative phase consisted of Direct Measurement with a descriptive statistical analysis.

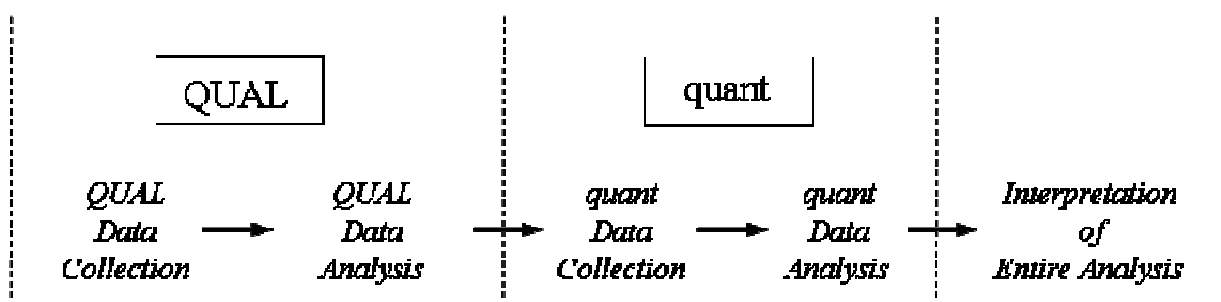

Figure 5. Sequential Exploratory Design. (Creswell, 2003, p. 213)

### *Grounded Theory*

Grounded Theory is a *general methodology* for developing theory that is grounded in data systematically gathered and analyzed. The theory evolves during the actual research, and it does this through continuous interplay between analysis and data collection (Denzin & Lincoln, 1998, p. 158). The intent of a Grounded Theory study is to generate or discover a theory that relates to a particular situation. This situation is one in which individuals interact,

take actions, or engage in a process in response to a phenomenon. To study how people act and react to this phenomenon, the researcher collects primarily interview data, makes multiple visits to the field, develops and interrelates categories of information, and either writes theoretical propositions or hypotheses or presents a visual picture of the theory.

The researcher typically conducts 20-30 interviews based on several visits “to the field” to collect interview data to saturate the categories or to find information that continues to add until no more can be found. A category represents a unit of information composed of events, happenings, and instances. The researcher also collects and analyses observations and documents, but these data forms are atypical. While the researcher collects data, she or he begins analysis. Data collection in a Grounded Theory study is a zigzag process: out to the field to gather information, analyze the data, back to the field to gather more information, analyze the data, and so forth. The participants interviewed are chosen using theoretical sampling, to help the researcher form the best theory. How many visits one makes to the field depends on whether the categories of information become saturated and whether the theory is elaborated in all of its complexity. This process of taking information from data collection and comparing it to emerging categories is called the constant comparative method of data analysis (Creswell, 1998, p. 56).

#### *Direct Measurement Research*

Direct Measurement or observation is one of the least common forms of data collection, largely because it is inordinately time-consuming and expensive. The primary advantage of Direct Measurement or observation lies in the reduction of bias. The information is subject to fewer perceptual filters (Maxim, 1999, p. 285). Direct

Measurement research methodology is a means of primary data collection conducted in the same manner as a survey. Like a survey, the primary purpose is to describe the characteristics of a population, but the data collection involves testing subjects or otherwise directly counting or measuring data (Rea & Parker, 1997, p. 3). As such, it is primarily a descriptive quantitative methodology. There are two major types, cross-sectional and longitudinal. A cross-sectional study collects information from a sample drawn from a predetermined population, while in a longitudinal study, information is collected at different points in time in order to study changes over time. The key steps in conducting Direct Measurement research are to define the problem, identify the population to include defining the unit of analysis, determine data collection mode, select the sample, prepare and test the instrument and data collection procedures, and conduct the measurements. Typically the unit of analysis is people, but it can also be objects, clubs, companies, classrooms, schools, and so on (Fraenkel & Wallen, 2003, pp. 396-401).

### Chapter Summary

This chapter provided a review of the literature related to the problem and literature related to the research design. The literature related to the problem addressed building codes and permits, environmental and public health laws and associated permits, the environmental impact of crib docks, and the structural requirements for safe and secure crib docks. This was followed by a review of literature related to mixed methods research design, Grounded Theory, and Direct Measurement research methodology design and execution.

### *Summary of the Literature Related to the Problem*

The literature related to construction codes provided a synopsis of the development of building codes and how building codes were instituted to improve public health and safety by applying developing materials science, architectural design, and structural analysis techniques to established problems. The primary rationale for residential building codes was to protect health and safety. The literature showed that a building code is a set of rules that specify the minimum acceptable level of structural quality for buildings and other structures, such as docks. The first comprehensive building codes were researched and developed by the fire insurance industry as a means of improving public health and welfare while protecting the industry's viability. Building construction regulation in the United States evolved from multiple specific, voluntary codes to a commonly accepted exercise of government police power. In 1999, Michigan adopted the International Building Code as the statewide residential code. The code and associated permit processes are well defined, clearly justified, and uniformly enforced statewide.

Formal environmental regulatory policies grew out of the need to protect people from the hazards of unregulated urban living conditions and to protect natural resources from the destructive effects of unconstrained free market activities. The first significant federal environmental legislation was the Rivers and Harbors Act of 1899, which made it illegal to obstruct or release pollutants into an interstate waterway without approval by the Corps of Engineers. However, there was no effective, full spectrum environmental legislation until President Nixon signed The National Environmental Policy Act (NEPA) in 1970. This landmark legislation established the first definitive environmental mandate for national policymakers. The State of Michigan's role in the NEPA and associated legislation was set



out in the Michigan National Resources Environmental Protection Act (NREPA), which addressed shared natural resources, set minimum standards for environmental protection, and detailed state responsibilities. The portions pertinent to crib dock construction permitting were: Part 303 - Wetlands Protection, Part 323 - Shorelands Protection and Management, and Part 325 - Great Lakes Submerged Lands. Building on this, the USACE-MDEQ Joint Application Permit Process was developed to facilitate the state and federal permit application process for regulated activities where the land meets the water. While the approval process was clearly delineated, the approval standards were not.

The environmental impact of crib docks focused on two diametrically opposed issues. On the positive side, crib docks have been shown to provide habitat complexity that enhances freshwater life. Investigators found that cribs were the only shoreline structures that had any significant effect on fish densities. Brown further found that, in the absence of natural woody debris, crib docks were the best manmade structure for encouraging forage fish to thrive. In 2004, the National Park Service determined that a crib dock option was the most effective option for meeting their boat moorage needs in Isle Royale National Park, while still protecting the sensitive environment. In Brevort Lake, the MDNR and the U.S. Forestry Service encouraged and complimented the use of submerged log cribs as a means for enhancing sport fish habitat and population. On the other hand, crib docks are said to interfere with the littoral zone ecosystem, by occupying lake bed and blocking littoral flow. As a result, they are strongly discouraged in public and governmental literature. Statements like “Since 1988, new dock constructions have shifted from crib-style to less habitat-destructive types such as post docks, floating docks and cantilever docks” were common.

However, follow-up contact with their authors did not result in any research to support the statements. This was an issue left to the research design.

The crib dock construction discussion addressed weathering, structural, and policy considerations. The literature showed that crib docks constructed of durable wood such as Douglas fir, larch, or hemlock, continually submerged in water, can last 30 years or longer without treatment. For design standards, a lateral ice load value of 10 kips/ft should be used. The review also showed that the cribs are built of opposing pairs of wood timbers, one pair laid out on top of the next, creating a slatted box with an integral floor. Threaded rods should be run the full height in each corner to secure the timbers in place. The crib dock policy findings stated that they should be built entirely on natural bedrock or sand bottom with a total combined footprint of not more than 15 m<sup>2</sup> [161 ft<sup>2</sup>], they should be sited to allow sufficient littoral flow area, and the ballast should be at least four inches in diameter and consist of clean rock, free of sand, silt, and clay, and be obtained off-site.

This review of literature related to the problem highlighted that very little scholarly research has been done related to crib docks or dock construction permit processing. As a result, the study design for this project will have to work with little background information and will need to develop baseline information in the course of the research process.

#### *Summary of the Literature Related to the Research Design*

Based on the literature review, a mixed methods research design was evaluated in the review of literature related to the research design. Mixed methods research started with researchers and methodologists who believe that both qualitative and quantitative viewpoints and methods are useful. Since the early 1990s, mixed methods has increasingly become

recognized as a third major research paradigm, along with quantitative and qualitative research methods. Mixed methods research is a synthesis that includes ideas from qualitative and quantitative research. It allows for the convergence of findings from two or more methods, which “enhances our beliefs that the results are valid and not a methodological artifact” (Johnson & Onwuegbuzie, 2004). The primary advantage of mixed methods is maximizing the strengths of each perspective while minimizing their inherent weaknesses. Mixed methods research design must consider the implementation sequence of the quantitative and qualitative data collection, what priority will be given to the quantitative and qualitative data collection, at what stage the quantitative and qualitative data and findings will be integrated, and whether an overall theoretical perspective will be used.

Given the nature of this problem and the limited available literature related to the problem, the study used a sequential exploratory strategy, using Grounded Theory in the initial qualitative phase, and Direct Measurement in the subsequent quantitative phase. The intent of a Grounded Theory study is to generate or discover a theory that relates to a research problem. The researcher collects primarily interview data, makes multiple visits to the field, develops and interrelates categories of information, and either writes theoretical propositions or hypotheses or presents a visual picture of the theory. Direct Measurement research methodology is a form of primary data collection conducted in the same manner as a survey. Like a survey, the primary purpose is to describe the characteristics of a population, but the data collection involves testing subjects or otherwise directly counting or measuring data.

### *Closing*

This literature review addressed literature related to the problem and literature related to the research methodology and study design. The initial discussion provided the historical, scholarly, and contextual background for the problem and its importance. It showed how public and commercial concern over building safety and unhealthy urban residential life led to numerous commissions and evaluations of building quality and standards. Based on those analyses, building codes were implemented to obligate builders to provide safer, healthier commercial buildings and urban residential living conditions. While the development of environmental laws was also in response to public demand for addressing public health and well-being issues, the standards for correcting those issues were not as clearly established or justified. In addition, the responsibilities for environmental issues continue to be somewhat muddled, and the permitting processes and approval criteria associated less well defined. This discussion set the stage for the initial thoughts on research methodology options, which guided the review of the literature related to the research design. Given the nature of this problem and the limited literature related to the problem, the study used a mixed methods sequential exploratory strategy, using Grounded Theory in the initial qualitative phase and Direct Measurement in the subsequent quantitative phase. Taken together, the literature review provided a succinct summary of the key issues to be considered in the final research design to be addressed in Chapter 3.

## CHAPTER 3

### RESEARCH METHODOLOGY & DESIGN

Chapter 3 discusses the research methodology selection and subsequent design to pursue the study problem and research questions. The chapter initially covers the research methodology selection in light of the problem introduced in Chapter 1 and the literature reviewed in Chapter 2. Chapter 3 then outlines, by phase, the methods used to explore the problem and address the research questions. Each research phase discussion addresses the phase design and procedures; identification of the population and sample; the instrumentation development; and the data collection, analysis, and validation plans. Chapter 3 also describes the human subjects review and the overall data integration and validation.

#### Research Objective and Questions

As stated in Chapter 1, this research evaluated crib dock construction methods throughout the Les Cheneaux and Drummond Island region of Michigan to establish defined permit and construction norms that meet the structural needs of owners, while respecting the greater public's desire to maintain safe waterways and protect the Great Lakes bottom land and associated water life and vegetation. The research questions addressed were:

- What are the key crib dock siting considerations? How does dock siting and orientation affect weather loads and associated durability?
- What are the crib design and construction minimums for given a set of site considerations?

- How does the decking and superstructure affect appropriate siting and crib design decisions?
- What are the minimum and optimum ground anchorage standards for appropriate design and durability?

### Methodology Selection

As the literature review highlighted, there is limited information concerning the broader problem being explored and almost none that addresses the research objective and questions. Therefore, this research design called for an exploratory mixed methods research methodology with the initial phase being qualitative and based on Grounded Theory procedures, followed by a quantitative phase using Direct Measurement procedures. In light of Creswell's model for exploratory mixed methods research (Figure 5), the research design model in Figure 2 was followed for this research study. Note that the same research questions were addressed in both phases, first qualitatively and then quantitatively. The model will be discussed in detail in the phase specific design discussions following the variable definition.

Given the exploratory nature of this research challenge and the design model used, there is no specified hypothesis presented and tested. This is appropriate in that there is no baseline knowledge set to work from in developing and pursuing a specific hypothesis. Rather this research focused on addressing a relatively unexplored topic by gathering data about the specified research problem and developing theory based on the data collected, and as the theory was developed and refined, new data requirements were identified and pursued. This Grounded Theory iterative approach to variable definition, data collection, and theory

development is the heart of the mixed methods exploratory research paradigm. Theory development ultimately focused on establishing accepted construction norms for use in the crib dock construction application process. The qualitative phase focused on establishing a baseline understanding of the problem and research questions and developing a data collection instrument for use during the subsequent phase. The quantitative phase focused on analyzing docks to determine appropriate values for the construction norms mentioned earlier. Therefore, the study design is strictly normative; there was no intent to use these findings in any inferential manner.

#### Variable Definition

With the research questions and design model as the starting point, the variables to be addressed and evaluated are listed in Table 2. Note that the variables selected operationalize the research questions. This set of variables was reconfirmed following the completion of Phase 1 and formed the baseline for the integrated results analysis.

#### Qualitative Phase - Grounded Theory.

The qualitative phase used the Grounded Theory approach in light of the limited baseline work available to build upon. As discussed in the literature review, the intent of a Grounded Theory study is to generate or discover baseline theory, which subsequent research will build upon. With that template in mind, the purpose of the qualitative phase of this research project was to confirm the limited available information and establish a baseline of knowledge to be used to develop a definitive data collection instrument for use in the quantitative phase. As portrayed in the research design model (Figure 2), this phase

addressed all of the four research questions. In keeping with the Grounded Theory approach, the process was pursued using iterative data collection.

Table 2

*Variable Definition.*

VARIABLES	OPERATIONALIZED	ATTRIBUTES
<i>Dock Siting</i>	<ul style="list-style-type: none"> <li>➤ <i>Semi-structured Interview.</i></li> <li>➤ <i>Direct Measurement.</i></li> <li>➤ <i>GIS Analysis.</i></li> </ul>	<ul style="list-style-type: none"> <li>• <i>Site fetch and orientation to prevailing winds.</i></li> <li>• <i>Dock shape and number of cribs used.</i></li> <li>• <i>Littoral flow gap at OHWM.</i></li> <li>• <i>Soil type.</i></li> <li>• <i>Littoral scouring and sediment drift.</i></li> </ul>
<i>Crib Design</i>	<ul style="list-style-type: none"> <li>➤ <i>Semi-structured Interview.</i></li> <li>➤ <i>Direct Measurement.</i></li> <li>➤ <i>Documents.</i></li> </ul>	<ul style="list-style-type: none"> <li>• <i>Crib width, length, and height.</i></li> <li>• <i>Crib spacing.</i></li> <li>• <i>Joint design.</i></li> <li>• <i>Fill &amp; installation method.</i></li> <li>• <i>Fastener hardware.</i></li> <li>• <i>Structural &amp; corner joints.</i></li> </ul>
<i>Superstructure</i>	<ul style="list-style-type: none"> <li>➤ <i>Semi-structured Interview.</i></li> <li>➤ <i>Direct Measurement.</i></li> </ul>	<ul style="list-style-type: none"> <li>• <i>Deck width.</i></li> <li>• <i>Structural materials used.</i></li> <li>• <i>Stringer gap, design, and materials.</i></li> <li>• <i>Joint methods, fasteners.</i></li> <li>• <i>Boat house implications.</i></li> </ul>
<i>Ground Anchorage</i>	<ul style="list-style-type: none"> <li>➤ <i>Semi-structured Interview.</i></li> <li>➤ <i>Direct Measurement.</i></li> </ul>	<ul style="list-style-type: none"> <li>• <i>Ground anchors used.</i></li> <li>• <i>Piling orientation.</i></li> <li>• <i>Piling spacing and reinforcement measures.</i></li> </ul>

*Qualitative Population & Sample Design*

This research focused on the Les Cheneaux and Drummond Island region of Michigan's northern Lake Huron shoreline, an area approximately 50 miles long (Figure 3). The area includes numerous islands, bays, and inlets, all of which are exposed to the severe northern Lake Huron winter weather. This phase of the research attempted to contact and



interview the entire population of established and informal dock builders in the research area. Informal contractors are part of the Upper Peninsula's shadow economy, workers making money "off the books" to avoid income taxes and protect their eligibility for public assistance benefits (Emery, 1996, p. 28). There were four formal crib dock contractors in the research area; the entire population was contacted. The unit of analysis for this phase of the research was individual respondents: dock construction contractors, dock owners, construction material suppliers, and government officials.

### *Qualitative Instrumentation*

Two general interview guides were developed from the available literature covering the construction, use, and environmental impact of crib docks. One interview guide focused on crib dock contractors, while the other focused on dock owners. They are included at Appendices 2 and 3. The interview guides served as conversation templates for semi-structured interviews to explore construction norms, techniques, and business practices. Tailored interview guides were developed for interviews with dock construction material suppliers and government officials associated with the dock approval process. A sample government official interview guide is provided at Appendix 4. Reviewing the interview guides shows that they address all four of the research questions in order to fully develop the baseline for subsequent quantitative exploration of the questions.

### *Human Subjects Review and Approval*

Human Subjects approval was obtained for this portion of the research to ensure adherence to established ethical research practices. The Eastern Michigan University Human

Subjects Review Committee approval is included at Appendix 5. Review and approval by the institutional Human Subjects Review Committee was sought because the project originally included pursuing dock cost data. There was some concern that cost data may include personal financial records, records that are sufficiently personal that informed consent would be necessary. However, as the research progressed and the research problem and questions came into focus, the cost aspects of the problem were eliminated. Hence, the nature of the material covered during the interviews was public in nature and informed consent was not required. To protect against inadvertent violation of any respondent's privacy or reputation, none of them were quoted or cited by name.

#### *Qualitative Data Collection*

The first phase of data collection was conducted primarily during July and August of 2006. It consisted of meeting with various dock contractors at their place of business or on job sites over a period of time and building a level of rapport. Building rapport with the respondent candidates was a critical step for this phase of the research project. It entailed meeting with builders and investing time to build relationships and even volunteering as a laborer to establish credibility. The interviews with dock owners were completed primarily during the second phase of the research while completing the dock data collection forms. The interviews with material suppliers and government officials were completed by appointment at their offices or place of business. In addition to the interview notes, the data from this phase included construction drawings, Clark Township dock and boat house ordinances, MDEQ-USACE Joint Application materials, and photographs of docks being constructed.

## *Qualitative Data Analysis*

### *Qualitative Sample Analysis*

The sample description will be a qualitative summary of the elements of the qualitative sample. The attributes considered: dock contractors, owners, and associated government officials. This sample description provided the basis for the qualitative data validation.

### *Qualitative Data Analysis*

Since this phase was conducted using a Grounded Theory approach, the data collection was iterative, in that information was collected and analyzed, and, based on insights gained and oversights identified, subsequent data collection was conducted. Since the data collection was iterative, the data analysis and interpretation was also iterative. The key findings or outputs of this phase were trends and issues discovered in the interview transcripts and the insights used to develop the dock data collection form for use in the second phase. In addition, there was a detailed analysis of the qualitative data by research variable in preparation for the final integrated data analysis.

### *Qualitative Data Validation*

One of the strengths of the Grounded Theory approach is the iterative data collection and the built-in respondent checking. This was reinforced by the investigator spending significant, prolonged time in the field ensuring complete, unbiased data collection. The research design and data collection allowed for more than two full months of data collection

over a period of three years. In addition, the dissertation committee chair maintained a summer residence in the area, which allowed for regular debriefs and bias checking.

#### Quantitative Phase - Direct Measurement.

The quantitative phase used Direct Measurement to collect the individual dock data. Direct Measurement was the most appropriate research mode given the research objective and questions; that is, the only way to develop information about the docks in use throughout the research area was to actually measure the key characteristics under consideration. In that very little literature is available that covers Direct Measurement data collection, the design methodology for survey research was used to guide the research design and planning. This was appropriate in that the two research methods are very similar except that in survey research the investigator is collecting opinions or impressions, whereas in Direct Measurement the investigator is empirically measuring the variables under examination. With that template in mind, the purpose of the quantitative phase of this research project is to collect sufficient dock data to establish norms for the serviceable, in-use crib docks in the research area. The specific process used was to develop a cross-sectional data set using structured Direct Measurement. Human subjects approval was not required for this phase of the research.

#### *Quantitative Population & Sample Design*

The population for this phase of the study included all of the crib docks in the Les Cheneaux and Drummond Island region. While no inventory of these docks is available, a review of the area indicates that there are an estimated 400 crib style dock structures

serviceable and in use. This phase of the research employed a convenience sample of serviceable, in-use crib docks. A convenience sample is a group of respondents, in this case docks, that are conveniently available for study (Fraenkel & Wallen, 2003, p. 103). The sample was obtained by identifying docks, visiting dock owners, and obtaining permission to examine and measure their docks, and subsequently discussing the docks with them. Those that were available and accessible were included in the sample. Based on an estimated population of 400 docks in the research area and a 90% confidence level, the sample needed to be 162 docks for the quantitative results to be +/- 5% of the population means. Given the time constraints, the calculated sample size was not workable. After discussions with the committee, the sample size was arbitrarily set at 20 docks, which meant the final results were +/- 15% of the population means. This level of validity was considered adequate given the baseline, exploratory nature of the study. In other words, the data analysis will be used in a descriptive manner rather than an inferential manner; there is no hypothesis to be tested.

### *Quantitative Instrumentation*

The dock site data collection form was developed based upon the insights and understandings gained during the qualitative phase data collection and subsequent analysis. At the conclusion of Phase I, the data collection form was refined to address each of the research questions and then tested during the evaluation of the crib docks built by the National Park Service in Tobin Harbor, Isle Royale National Park, in Lake Superior. Then prior to initiating Phase II data collection, the instrument was adjusted and peer reviewed by the committee chair and one of the contractor respondents from Phase I. In the final design,

the instrument included both Direct Measurement attributes and qualitative attributes. The dock site data collection form is provided at Appendix 6.

#### *Quantitative Data Collection*

The second phase of data collection was conducted during July and August of 2007. It consisted of visiting dock owners, explaining the project, and asking for permission to examine their personal docks. Then a dock site data collection form was completed for each of the docks examined. As time and situation allowed, the dock owners were interviewed.

#### *Quantitative Data Analysis*

##### *Quantitative Sample Analysis*

The sample description will be a qualitative summary of the elements of the dock sample. The attributes considered included dock size, location, mainland versus island installation, and personal or commercial usage. This sample description provided the basis for the internal threat analysis.

##### *Quantitative Data Analysis*

The descriptive data analysis by research variable consists of the computed descriptive statistics for the key quantitative attributes of the sample. These descriptive statistics provided the basis for many of the recommended structural norms for crib docks being considered for construction approval. The analysis by research variable considered both the qualitative attributes as well as the measured attributes collected during Phase II.

These were considered and analyzed in groupings as they pertained to each of the four primary research variables.

### *Quantitative Data Validation*

The quantitative phase data validation consisted of data review, data verification, and internal threat analysis. The data review included the qualitative steps taken while still in the research area to ensure the quantitative data set was complete and accurate. The data verification comprised a series of detailed steps taken during the data reduction and analysis to ensure the data entries on the data collection forms were accurate and valid. The key checks included identifying missing values, range checking, and validity checking. The internal threat analysis examined the sample to confirm or refute the possible internal threats: sample bias and sample size.

A sample bias is a built-in skewing of the sample based the manner in which the sample is obtained (Moore & McCabe, 2003, p. 249). The sample for this phase of the study was determined by knocking on doors and asking residents to allow the investigator to look at the owner's dock. The sample was biased towards docks built on or accessible from the mainland versus those built on one of the research area's many islands. This occurred for two reasons: 1) the investigator did not have regular unfettered access to a boat; and 2) it was more acceptable to initiate contact by knocking on a resident's door than by walking up from their dock, as island residences are accessed from their docks. There was no reason to believe that the docks would be constructed differently on the islands than on the mainland, but it was a sample bias that needed to be considered. The sample bias analysis consisted of

considering the characteristics of sub-samples to determine if there was any inadvertent weighting the total sample by overpopulating with one particular sub-sample.

The limited sample size is a result of the labor intensive nature of Direct Measurement research, which included locating appropriate dock structures, obtaining permission to examine a dock, and then analyzing the dock. At best, the investigator was able to analyze two docks a day, often fewer. Due to the research time window and competing priorities, the dock sample consisted of only 20 docks. This sample size was carefully considered in the Phase II data analysis, as well as the final integrated analysis.

## Data Integration and Analysis

### *Integrated Data Analysis*

The data analysis for each phase concluded with an analysis by research variable. The data integration included taking the separate analyses and merging the results into a coherent whole. The key aspect of the data integration was to ensure that validity and reliability were considered in the final data integration.

### *Integrated Data Validation*

Creswell and Plano Clark (2007) cite key issues to analyze during data collection and data analysis in evaluating the validity of an exploratory sequential mixed methods research design. During data collection, they emphasize 1) selecting different sample elements for each of the phases; 2) using a relatively small sample for the qualitative phase and larger sample for the quantitative phase; 3) using the same respondents for any follow-up; and 4) ensuring rigor in designing the data collection instruments. During data analysis, they



emphasize 1) focusing on significant results; 2) pursuing key themes or issues in the quantitative follow-up; and 3) addressing both qualitative and quantitative validity (Creswell & Plano Clark, 2007, p. 148). Each of the cautions has been addressed in assembling the validity checks designed for this study. The checks to assure data validity included:

- Over eight weeks of hands-on field data collection. This prolonged field time ensured a clear understanding of the processes involved and their relative merits and costs.
- Triangulation of the interview results with the information gained from the dock site visits, construction records, and discussions with dock owners.
- Member checking by having selected respondents review the draft results and verify their accuracy.
- Use of the dissertation committee as external auditors to ensure the entire project was valid and accurate.
- The identification of one subject matter expert, C. Allen Wortley, Professor Emeritus, Department of Engineering, University of Wisconsin – Madison. Professor Wortley’s area of expertise is northern Great Lakes small craft harbors. He provided direction and guidance as the research progressed and reviewed the findings and conclusions upon completion.

### Chapter Summary

Chapter 3 outlined the methodology selection, variable definition, research design, and research procedures employed. The study employed an exploratory mixed methods model, which is a two phase sequential methodology with the initial phase being qualitative

and the subsequent phase quantitative. The qualitative phase used the Grounded Theory approach with its trademark iterative data collection, interim analysis, and subsequent data collection. The primary data collection tool was semi-structured interviews with crib dock contractors, owners, construction material suppliers, and government officials associated with approving the construction permits and standards. The quantitative phase employed Direct Measurement of in-service crib docks using an instrument developed based on the results of the qualitative phase. The instrument was primarily focused on deterministic attributes, but some qualitative attributes were included as well. The discussion of both phases included definition of the population and sample, instrumentation, and data collection, validation, and analysis. Human subjects approval was obtained for Phase I but subsequently determined to be unnecessary. Chapter 4 presents the data as collected, the data analysis and validation, and the study findings.

## CHAPTER 4

### PRESENTATION & ANALYSIS OF FINDINGS

This chapter presents the findings for the study's qualitative and quantitative phases and then integrates the two sets of results and analyzes them as a whole. The results are presented in the order that they were completed: qualitative, quantitative, and integrated. Each of the phase presentations discuss how the data were collected, the data analysis used for that research paradigm, and the data validation checks employed. The data analyses use the research objective and questions as a discussion template.

#### Research Objective & Questions

This research evaluated crib dock construction methods throughout the Les Cheneaux and Drummond Island region, to establish defined permit and construction norms that meet the structural needs of owners, while respecting the greater public's desire to maintain safe waterways and protect the Great Lakes bottomland and associated water life and vegetation. The research questions addressed were:

- What are the key crib dock siting considerations? How does dock siting and orientation affect weather loads and associated durability?
- What are the crib design and construction minimums given a set of site considerations?
- How does the decking and superstructure affect appropriate siting and crib design decisions?

- What are the minimum and optimum ground anchorage standards for appropriate design and durability?

## Qualitative Phase - Grounded Theory

### *Qualitative Data Collection*

The primary data collection for the qualitative phase occurred over four weeks between July 16 and August 13, 2006; the primary quantitative data collection was completed July 26 to August 16, 2007; and follow-up data collection for both phases was done in May and July of 2008. During this time, multiple interviews were conducted with crib dock and other dock style contractors; crib dock owners; federal, state, and local government officials; and dock construction materials suppliers. As discussed in the research design, the qualitative phase was conducted using the Grounded Theory research approach, which calls for returning to previous respondents for follow-up inquiry as needs dictate. As a result, while the qualitative phase provided the basis for the quantitative phase data collection instrument, the iterative qualitative data collection continued through to the study's completion. The primary qualitative sample was a purposive sampling of dock contractors throughout the research area. It was a purposive sample in that the sample design was focused on meeting with and interviewing every dock contractor in the research area. The sample identification and data collection proceeded by identifying dock contractors in the research area, visiting them, and then revisiting them as needed; some of the contractors were visited up to eight times. As the investigator worked through the list of formal contractors, other interview respondents were identified and subsequently visited. A similar process was used in identifying docks and interviewing their owners and in identifying key government

officials and meeting with them. This interactive process is in keeping with the Grounded Theory research paradigm and provided a rich data set upon which to base the subsequent quantitative data collection.

### *Qualitative Sample Analysis*

As shown in the qualitative phase sample analysis in Table 3, the qualitative sample consisted of six dock contractors, eight dock owners, nine government officials, and two construction material suppliers. In all, 39 interviews were conducted: 16 with contractors, 12 with crib dock owners, and 11 with various government officials and building material suppliers. The dock contractor sample included one relatively large operation with multiple employees, two modest operations with three to seven employees, and the balance small one- or two-man operations. The large corporate operation previously constructed primarily crib docks but now does primarily sheet piling bin wall style docks. In addition, one floating dock contractor was interviewed. Bin wall and floating docks are the only other reasonably common dock systems used in the research area. The initial interviews with the contractors and the interviews with the government officials typically took 50 to 70 minutes to complete. The dock owner interviews lasted from 15 to 60 minutes depending on the respondent's willingness to participate. All the follow-up interviews typically ranged from 15 to 60 minutes each.

Table 3

*Qualitative Phase Sample Analysis*

<u>CONTRACTORS</u>		<u>CRIB DOCK OWNERS</u>		<u>GOVERNMENT OFFICIALS</u>	
<b>Respondent A</b>	<b>8</b>	<b>Respondent 1</b>	<b>5</b>	<b>MDEQ</b>	<b>2</b>
20 Jul 06		17 Jul 06		3 Aug 06	
24 Jul 06		18 Jul 06		2 Apr 08	
26 Jul 06		29 Jul 07			
1 Aug 06		5 Aug 07			
30 Jul-07		11 May 08			
3 Aug 07					
10 Aug 07					
14 May 08					
<b>Respondent B</b>	<b>2</b>	<b>Respondent 2</b>	<b>1</b>	<b>USACE</b>	<b>3</b>
18 Jul 06		7 Aug 07		2 Aug 06	
13 Aug 07				1 Apr 08	
				5 May 08	
<b>Respondent C</b>	<b>2</b>	<b>Respondent 3</b>	<b>1</b>	<b>USFS</b>	<b>1</b>
19 Jul 06		29 Jul 06		May 08 (by e-mail)	
22 Jul 06					
<b>Respondent D</b>	<b>2</b>	<b>Respondent 4</b>	<b>1</b>	<b>MDNR</b>	<b>1</b>
27 Jul 06		1 Aug 07		25 Apr 08	
12 May 08					
<b>Respondent E</b>	<b>1</b>	<b>Respondent 5</b>	<b>1</b>	<b>Clark Township</b>	<b>2</b>
31 Jul 06		7 Aug 07		25 Jul 06	
				13 May 08	
<b>Respondent F</b>	<b>1</b>	<b>Respondent 6</b>	<b>1</b>	<b>Material Suppliers</b>	<b>2</b>
6 Aug-06		8 Aug-07		13 May 08	
				17 May 08	
		<b>Respondent 7</b>	<b>1</b>		
		13 Aug 07			
		<b>Respondent 8</b>			
		3 Jul 08			
<b>TOTAL</b>	<b>16</b>		<b>12</b>		<b>11</b>
<b>GRAND TOTAL of</b>	<b>39</b>	<b>Interviews conducted.</b>			

## *Qualitative Data Analysis*

### *General*

Representatives of both USACE and MDEQ are opposed to crib docks because the docks are an obstruction to navigable waterways and occupy Great Lakes bottomland, which is contrary to Section 10 of the U.S. Rivers and Harbors Act and the Michigan NREPA Part 325 – Great Lakes Submerged Lands. A USACE official stated that the Les Cheneaux region is about the only place on the upper Great Lakes that are exposed enough to require crib supported piers, yet protected enough for them to last. One of the MDEQ representatives stated that crib dock approval standards are “rather informal and not really written down anywhere.” When asked about research that established the ill effects of crib docks on the bottomlands, another MDEQ representative stated, “You’re probably not going to find anything.” He went on to explain that crib docks in the research area are a historic feature with an established cultural role. He stated that they are approved in the Les Cheneaux but are generally not approved in other parts of the state. This last statement appeared to be an overstatement in that recent crib docks were observed in other parts of the upper peninsula, specifically Munising and the Keweenaw, although they are not as common as in the research area.

While the MDEQ and USACE discourage crib-based structures, the MDNR and U.S. Forest Service (USFS) support their use. One example was the Brevort Lake project outlined in the literature review. In that project, USFS biologists are working with local sportsmen to install crib structures in Brevort Lake, near St. Ignace, specifically to enhance sport fish population. The MDNR representatives did point out that there is no definitive research that directly links fish population to crib-based structures. However, they felt there is sufficient

experiential data to warrant their use. This is in concert with observations made throughout the research area. Further discussions with representatives of the MDNR indicated that they are constantly looking for viable options to increase and enhance water life habitat. The MDNR representative clearly understood the concerns over Great Lakes submerged lands preservation, but pointed out that crib-based structures generate far more surface area than they consume. Surface area is critical to benthic invertebrates and macrophytes, which feed and support fry fish. To verify this, the investigator calculated that an eight-foot-square crib in five feet of water consumed 66 square feet of lake bottom area while creating over 1100 square feet of submerged surface area (See Appendix 7). While the MDNR representative felt the crib surface was of equal ecological value, there is no research to confirm the statement.

In discussions with contractors and owners, the consistent impression is that it can take up to three years to get a new dock permit approved, whereas the USACE and the MDEQ contend that as long as there are no unusual conditions, the processing should take not longer than 60 to 90 days. Oft times, the impression of extended processing time is a result of sequencing: a few months for the owners to decide what they want and can afford; a few months for contractor design and owner approval; three to four months for MDEQ consideration; another two to three months for USACE approval; and then two to three months for actual construction. That totals at least a year, plus one or two winter delays, causing the approval process to appear to take up to three years from the time the owner begins to explore dock options to the completion of their new dock.

Throughout the dock approval process, the local township's only formal role, according to the township building inspector, was assuring the proposed dock met property



zoning requirements. The township checks property line set backs and the amount of planned dock structure in relation to the amount of shoreline that belongs to the owner. These are regulated by the Clark Township dock and boathouse ordinance, but little else is regulated. The township considers boat docks to be temporary structures and therefore exempt from meeting residential building code standards. This is in spite of the docks' expected serviceable life in excess of 30 years. Therefore, no design, construction, or utilities standards are inspected or enforced in the design approval, dock construction, or commercial maintenance of crib dock structures.

According to contractors, the permit approval process is about \$500 for a routine permit with drawings and surveys. This is accurate, because crib dock construction is considered a major project. Per Part 325 of the NREPA, Great Lakes Submerged Lands, crib docks are considered major projects because 1) they are not included in the specific listing of what constitutes a minor project; 2) they will occupy Great Lakes bottomland, which is state property; and 3) they will interfere with littoral flow, a specified issue of interest. Beyond the application fee, the cost can run much higher if there are challenges, special conditions to be evaluated, or legal proceedings as a result of formal challenges.

The contractors estimate that a crib dock currently costs between \$250 and \$1000 a running foot, depending on the site and design. The cost is not surprising considering that the majority of the construction work is done by hand. However, if a dock is well sited, built, and maintained, it should provide well over 30 years of service in what is a very demanding climate. Crib docks are the most reasonable alternative for pleasure craft moorage in an exposed setting with significant winter fetch run. A location's fetch is the meteorological term for the distance wind can travel unobstructed prior to reaching the location. It is a

critical variable in assessing a site's degree of exposure to winter ice loading. The other dock alternatives employed to a limited degree are floating docks and bin wall docks. Simple piling supported docks are not used due to their susceptibility to failure resulting from ice jacking. The floating dock contractor admitted that while floating docks have many advantages, notably the minimal environmental impact, they are not as durable. In order to make them durable enough to withstand the winter ice loads requires substantial reinforcement and pilings for protection, which makes them significantly more expensive. These docks were more common in the more protected areas of the research area, such as the Les Cheneaux Channel. The other option that is used, sheet piling bin wall docks, which consist of heavy duty corrugated steel planks that are driven into the ground creating essentially a steel box, are more durable and surprisingly comparable in cost. The cost is comparable to crib docks primarily because most of the effort is mechanized. However, bin wall docks include significantly more adverse ecological impacts than crib docks. They provide little useful fish habitat, are a serious impediment to littoral flow, and are esthetically unsightly due to their industrial appearance. The only place bin wall docks were found in the research area was the public marina in Hessel and the more exposed sites on Drummond Island.

### *Dock Siting*

The key to a dock's useable life expectancy is ensuring that a dock is designed properly in light of a proposed site's topography and fetch. In extreme situations, the dock may need to be designed so that the lakeward end is reinforced with oversized cribs or angling the dock to face into the prevailing winds. The oversized cribs provide greater

ballast for counteracting seiche induced ice jacking or wind loading, while angling the dock to face into the maximum fetch, like the dock in Figure 6, minimizes fetch exposure. During construction, very little site preparation is required or even allowed because disturbing the bottom is detrimental to the environment. At most, the site work might include a minimum of leveling to ensure the cribs sit level. The other option, mentioned by some contractors, is to construct the cribs so that they are slanted on the bottom to conform to the lake bed slope. This avoids disturbing the lake bed substrate. Significant site preparation is required only when a preexisting dock must be removed. Owners often deal with this by using a boat motor's propeller wash to illegally dredge the shallow areas, amplifying the adverse environmental effect from the blocked littoral flow.



*Figure 6.* Crib dock with lakeward end angled to face anticipated ice load.

The only effective way to alleviate these effects is to leave sufficient flow gap between the cribs, minimizing interference with the littoral flow. To minimize blocking of the littoral flow, the MDEQ and USACE accept 11 feet between cribs, 7 feet under boat

houses. In the past, they pressed for 16 feet, but the contractors convinced them that the 6"x 6" timbers commonly used as deck joists could not safely span 16 foot gaps. For cribs placed to support a boathouse, the MDEQ will accept seven foot gaps, which appears to provide adequate structural foundation. However, per the township inspector, no structural data or standards currently exist to validate this norm. The MDEQ does not allow any cribs to be placed across the ordinary high water mark (OHWM), because maintenance of the close-in littoral flow is the most critical for habitat and shoreline maintenance. In general, the MDEQ stated that optimally a dock should allow at least 50 percent free flow space with at least a 10-foot flow gap at the OHWM, but they will accept 40 percent. For a dock that extends 100 feet out from the OHWM, a 40 percent free flow gap would mean that the sum total of the gaps between the cribs would be at least 40 feet. The ill effect of impeded littoral flow was seen repeatedly throughout the data collection.

### *Crib Design & Construction*

In constructing cribs, the research area contractors used cedar primarily due to its price and availability. According to the dock builder in Cedarville, the best option is Poplar or White Pine, but they are no longer available in sufficient quantities to meet demand. Recall from the literature review that the U.S. Forest Service recommends Douglas Fir, Tamarack Larch, or Hemlock. The reference goes on to say that "Wood that is continually submerged will not decay because no oxygen is present" (Neese et al., 2002, p. 6). So, as long as it is not exposed to air, any structurally suitable and available timber is appropriate for crib construction. Therefore, timber choice is driven by regional availability. Environmentally approved pressure treated timbers are available, but according to the

contractors they cost three times as much. Clear, straight rough cut eight to ten inch cedar timbers 20 feet long run \$25 a piece. Finished 20 foot long 6" x 6" pressure treated timbers were found locally to be \$65 each, roughly 3.5 times as much. Using pressure treated timbers certainly make the docks distinctly more expensive for limited gain in serviceable life of the cribs.

The crib dimensions vary based on the site's degree of exposure. As a minimum, all cribs should be at least 8 feet wide and 8 feet long, which leaves 7 feet of internal open space for ballast (see Figure 7). The MDEQ prefers the smallest crib possible, but anything less than 8 feet square is not large or stable enough to withstand the typical ice loading. For highly exposed sites with greater than normal ice loading, the cribs need to be lengthened to 12 or 16 feet long in order to provide sufficient strength and durability. In extreme cases, the lakeward end cribs may have to be built 12 to 16 feet square. The crib timbers are usually notched at the corner joints to provide rigidity and extend about one foot beyond the joints to

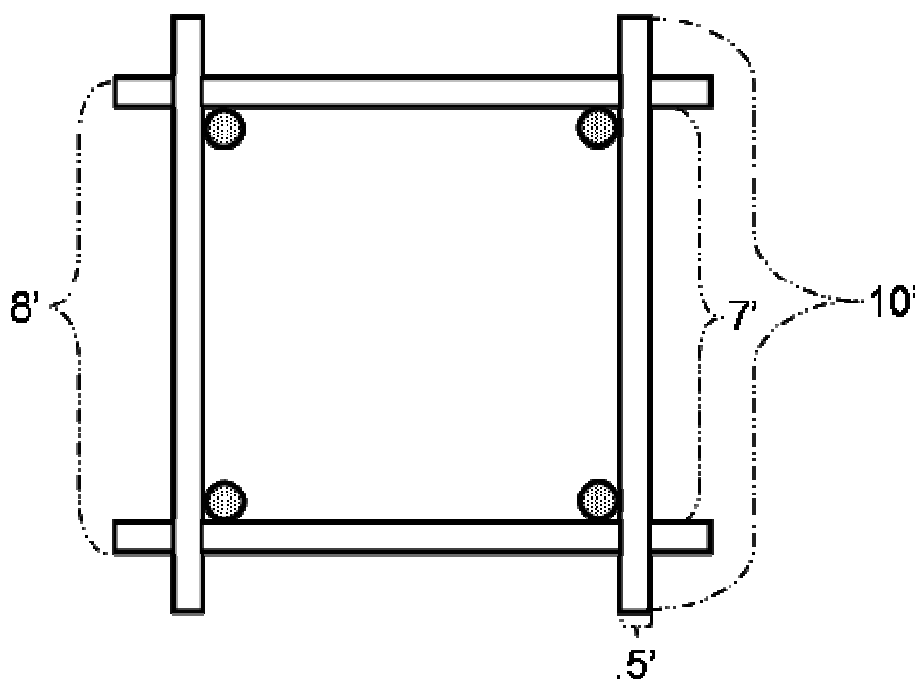

*Figure 7.* Layout of a basic 8 foot crib

protect against splitting. The primary fastener used throughout the research area was the 12” galvanized timber spike, straight as opposed to twisted-thread. In addition to timber spikes, lag bolts and vertical through bolts were also used to secure the corner joints, although they were less common. As the name implies, the timber spikes were simply a 12” long common nail with a 3/8” shaft; they currently cost \$1.70 a pound or about \$.85 each. One to two spikes were used to reinforce each joint or connection. Interestingly, the spikes are the one aspect of the cribs most susceptible to water exposure. One contractor was emphatic that cribs must be built so that the sides are solid without spaces between the timbers (Figure 8). He accomplished this by using deeper corner notches, much like a traditional log cabin, and then fasteners were added to the lateral timber members along the sides. This was the only contractor that felt this way and is a question left for exploration during the quantitative research phase.

In addition to the frame, crib construction includes a flooring (Figure 9). The crib floor consists of four- to six-inch timbers placed at three- to four-inch spacing across the lowest tier of the crib frame. The crib floor must be strong enough to contain the ballast during on site assembly and subsequently during ice induced shifting. Once the cribs are assembled and on site, they are floated generally into place and loaded with ballast until they reach just over neutral buoyancy. They are then precisely sited and fully loaded with ballast. The ballast rock is brought in from off site to protect the local ecosystem. According to one local supplier in the research area, the ballast used is unwashed crushed quarry limestone ranging in size from 6” to 12” in diameter and running 1.3 ton/yd<sup>3</sup>. Washing the ballast stone, which would remove fines and contamination, is not required by federal, state, or local



*Figure 8.* Dock Cribs Constructed with no Spacing Between Cross Timbers



*Figure 9.* Dock Crib Being Constructed with the Floor In Place

regulations. Use of unwashed ballast minimizes the interstitial habitat space provided by the dock cribs, because much of the space is filled with fines. There was no indication that the ballast stone is inspected or certified to be contaminant-free prior to loading. This is not a problem today, because the quarry stone is all virgin material. It could become a problem if recycled aggregate were used. A typical eight foot square crib requires 10 to 12 ton of quarry stone for ballast.

### *Dock Superstructure*

The cribs are normally tied together using 6" x 6" timbers, which serve as deck joists. As stated earlier, the crib spacing is normally 11 feet for open dock area and 7 feet for boathouse foundations. The builders contended that 6" x 6" spans greater than 11 feet had too much flex to be safe or structurally sound. To reduce joist and deck flex, the two 6" x 6" timber stringers are typically supplemented with one or two intermediate joists. Depending on the builder, the intermediate joists are 6" x 6", 4" x 6", or 2" x 6" yellow pine. The decking itself typically consists of untreated yellow pine, either 2" x 6" lumber or 5/4" x 6" decking. According to one builder, about 20% of new docks are decked with 5/4" x 6" cedar plank decking. None of the builders regularly use treated lumber for the decking, but one of the builders treats completed decks with a common wood deck preservative. Treated 2" x 6" lumber ran \$.75 a foot as compared to \$.45 per foot for untreated 2" x 6" decking.

The span limitations discussed above raised a question about using 6" x 6" timbers for joists. As was discussed in the literature review, a dock deck is essentially the same as a residential patio deck, which, according to the Michigan Residential Code codes, and as interpreted by most local building codes, are to be built with two inch lumber for joists. A



2" x 10" joist on 16" centers can span over 15 feet, and a 2" x 12" can span nearly 18 feet (Residential Building Code, City of Ann Arbor, 2004; MDLEG, 2003, p. 90). These seemed like the logical choice for the dock joists as well, and the greater spans would allow for greater flow gap. When asked about this, one builder said the air moisture in and around docks would quickly destroy 2" material unless treated lumber is used. In contrast, the 6" x 6" timbers have sufficient mass to withstand the moisture and will provide acceptable deck support 10 to 15 years. This is a topic that was left for further exploration in the quantitative phase.

### *Ground Anchorage*

Throughout the research area, pilings were the primary ground anchorage system used for crib docks. However, the frequency, placement, and positioning of pilings was not consistent. The spacing mentioned during interviews ranged from 4 to 8 feet. Some contractors said only 4 foot centers, while others said 8 foot centers near shore narrowing to 4 foot centers at the lakeward end. One contractor stated that there should be no physical connection between the pilings and the cribs to allow for raising and lowering during ice jacking cycles. Another contractor called for three pilings driven at the corners of cribs at the lakeward end of docks with a cable installed around the crib corners (Figure 10), while still another contractor felt strongly that the pilings should be driven butt end down. He stated that this would put the tapered end up and make it more difficult for the ice to grip the piling and pull it out during ice jacking. Another contractor countered that he had not detected any durability difference and that owners prefer the appearance of pilings driven with the butt end up. In contrast, the one Keweenaw region builder interviewed stated that in Lake Superior

pilings would not drive due to the nature of the lake substrate. He simply used larger cribs with no pilings at all and only ballast to secure the cribs in place. Still another contractor drove pilings only when necessary. Whenever possible, he placed pilings using a water jet to drill post holes in the lake bottom to receive and set the pilings. The issue of piling spacing and connection was also left to be further explored during the quantitative phase.

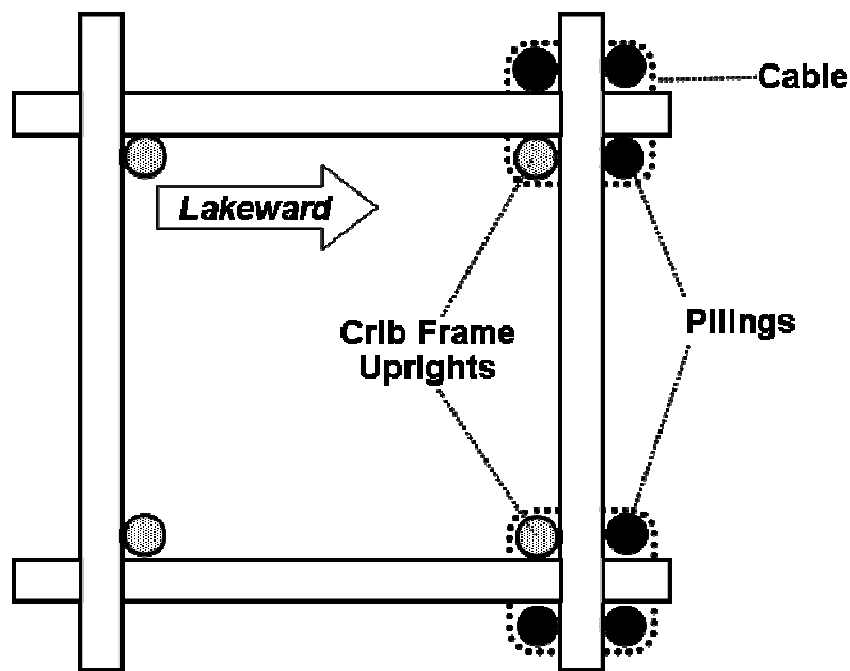

*Figure 10.* Piling Groupings of 3 Placed at the Lakeward Corners

#### *Qualitative Data Validation*

The data validation will address the key issues identified in the research design that affect the findings to this point: sample size, sample diversity, and instrumentation.

### *Sample Size*

As recommended by Creswell and Plano Clark, the qualitative sample was relatively modest in size, keeping with the exploratory sequential research design. As discussed earlier, the qualitative sample consisted of 39 interviews with 23 different respondents: six dock contractors, eight dock owners, nine government officials, and two construction materials suppliers. The initial interviews typically took 50 to 70 minutes to complete, while the follow-up interviews took from 15 to 60 minutes each. This meant the total qualitative sample included over 30 hours of interview transcripts, primarily with contractors but also with government officials, materials suppliers, and crib dock owners. This was a sufficiently large sample to identify key trends and issues, assure response stability across the primary variables, and allow for the development of an effective instrument for the quantitative research phase.

### *Sample Diversity*

Each of the three sub-samples achieved appropriate diversity for their sample specific characteristics. The contractors included large, modest, and small operations with representatives from the Hessel, Cedarville, and Drummond Island geographic areas. Similarly, the crib dock owners included a balance of both island and mainland dock sites from the three geographic areas. The government officials and building material suppliers contacted represented each of the key agencies involved with crib docks in the research area: the MDEQ, the USACE, the MDNR, the USFS, and the local township. A significant weakness in the sample diversity for both the contractor and dock owner sub-samples was the concentration of follow-up interviews with a limited number of respondents. For the

contractors, half of the interviews were with one respondent. For the dock owners, a third of the interviews are with one respondent. This in-effect sample weighting needed to be monitored closely during the quantitative phase and data integration to guard against unintentionally skewing of the findings based on minority opinions. The primary approach was to ensure that findings from the qualitative phase were handled appropriately and to ensure the dock sample included docks built by all of the primary dock contractors. It was also an issue addressed during the follow-up data collection; interviews were conducted during the follow-up data collection to better balance the builders sample.

### *Instrumentation*

As was discussed in Chapter 3, the qualitative instrumentation consisted of interview templates as opposed to rigidly defined interview scripts. This was done for two reasons, the local culture and the nature of Grounded Theory research. The local culture in the research area is stereotypic rural, small town America. The local truism is that you are not considered a “local” until you have lived in the area for at least a couple of generations. As a result, they know who everyone is and are suspicious of outsiders of any kind. Therefore, the interviews had to be kept rather informal and conversational in order to achieve the desired level of interaction and insight. This informality was compounded by the iterative nature of Grounded Theory research. Multiple follow-up interviews with contractor respondents were necessary to establish the required level of rapport, but it undermined any formal interview instrumentation as many of the follow-up sessions occurred on work sites, at the marina, or in a local store parking lot. These settings precluded formal instrumentation as it is commonly defined. Nonetheless, the investigator kept a consistent log of all conversations

and maintained a clear set of goals in mind for each successive session with owners and contractors alike.

## Quantitative Phase - Direct Measurement

### *Quantitative Data Collection*

The primary data collection for the quantitative phase occurred over four weeks between July 26 and August 16, 2007. During this time, Crib Dock Data Records (Appendix 6) were completed on 20 crib docks located within the research area (Figure 3). The dock sample was convenience based in that the docks selected were those that were convenient and accessible to the investigator. The docks fell into two general categories, private and commercial. In general, the data collection process proceeded by first identifying dock candidates. This was typically achieved by driving to a landing or other exposed shoreline area and scanning for crib docks. Once a candidate was identified, the investigator would approach the residence or commercial entity, introduce himself, and explain the study and ask to be allowed to examine the dock. Examining a dock and completing the data record typically took up to 2.5 hours. As timing and opportunities presented themselves, the investigator would interview the dock owners as discussed in the qualitative results. The investigator could typically complete two Crib Dock Data Records per day, sometimes less, rarely more.

### *Quantitative Sample Analysis*

As shown in Figure 11, the quantitative sample consisted of 20 docks from across the research area. The 20 docks included incorporated 151 individual cribs. All the data set

docks were in the defined research area, but were geographically dispersed: two were on Drummond Island, 17 were in the Les Cheneaux proper, and one was in between, just east of the Les Cheneaux region. Fourteen of the docks were located on the mainland and six were on islands. Ten of the docks were privately owned and ten supported some form of commercial enterprise or an island community. There was no difference in the design or site layout of the island versus mainland docks or the commercial versus private docks. However, the commercial docks typically had multiple seasonal dock fingers added to the central dock to handle more craft than the dock alone could accommodate.

In response to the concern raised in the qualitative data validation, the sample was well distributed across the contractor respondents: five docks were built by Respondent A; three by Respondent B; one by Respondent C; and three by Respondent D; for eight of the sample docks the contractor could not be determined. All of the docks were in a useable state, but seven of the docks were rebuilt from previously existing docks, and two docks were essentially landlocked due to low lake levels. The only dock analyzed outside of the research area was one of three crib docks at Isle Royale National Park. This dock was analyzed in the testing of the quantitative phase data collection instrument (Appendix 6).

### *Quantitative Data Analysis*

#### *General*

As is endemic to quantitative studies, the quantitative phase data collection focused exclusively on collecting and analyzing the data set docks. As a result, there were no significant quantitative findings applicable to the construction permit processing issues and concerns of the study. The data for the quantitative findings are presented in four tables at

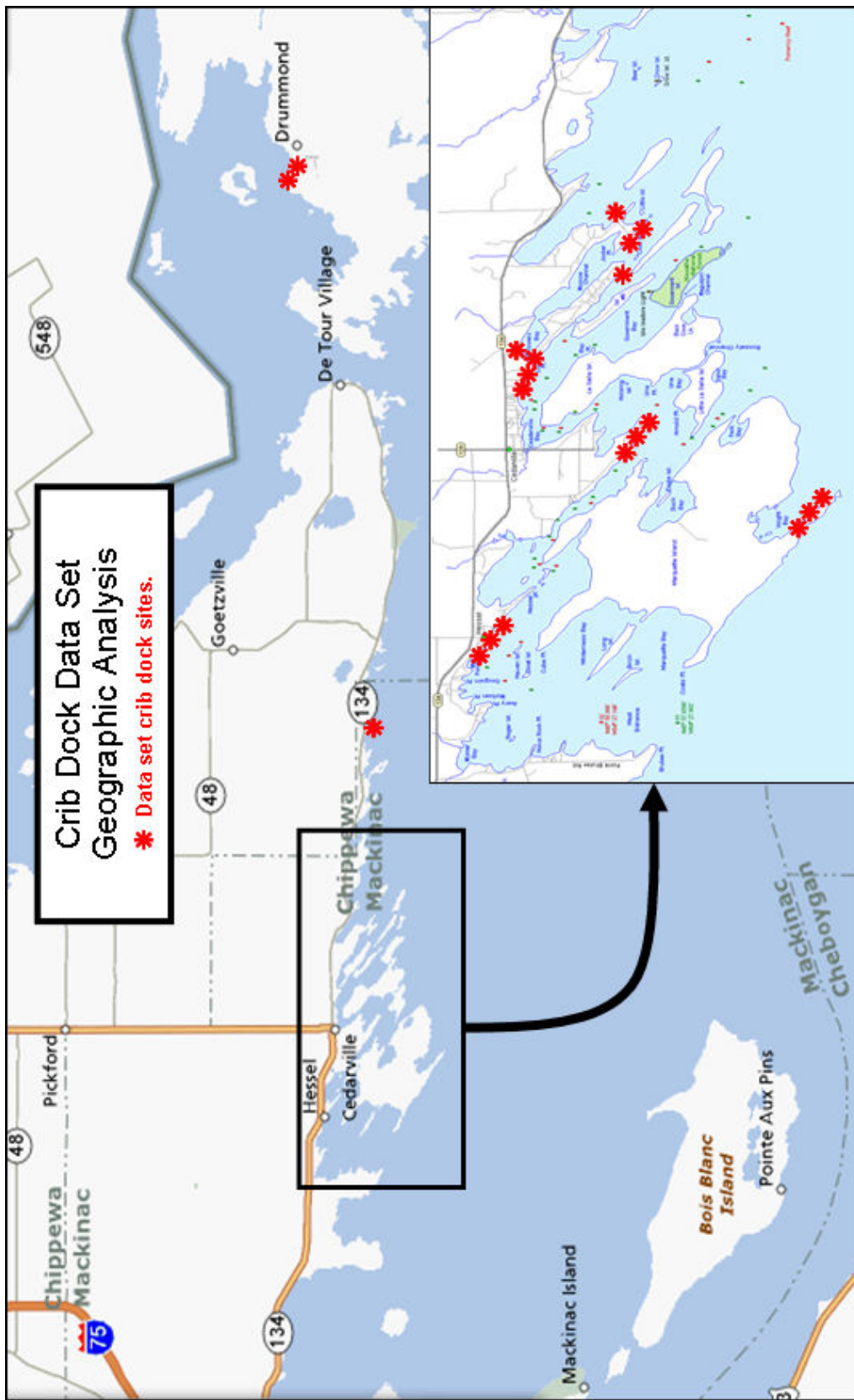

Figure 11. Crib Dock Data Set Geographic Analysis. .

the end of this chapter: 1) the site data set; 2) the crib data set; 3) the superstructure data set; and 4) the ground anchorage data set (See Tables 4, 5, 6, and 7).

### *Dock Siting*

The specific siting of each of the sample docks is provided in detailed GIS schematics provided in Appendix 8. The docks were generally sited in locations with gradual approach topography and gradually inclined bathymetry below the ordinary high water mark (OHWM). This is more a result of regional topography than any dock siting choice. In general, the research area topography consists of gently rolling to moderately rolling glacial till. Sixty-five percent of the docks were built on a soil type of Sheltered Cobbly Loam. The Shelter series consists of very deep, somewhat poorly drained, soils formed in loamy glacial till on ground moraines, drumlins, and glacial lake benches. They are a shallow to dense till. Slopes ranged from 0 to 15 percent (USDA NRCS, 1993).

Given the overall geography of the research area, maximum site fetch direction was typically southerly to easterly, with the fetch exposure ranging from less than a mile to full Lake Huron exposure. However, according the 2007-08 data from the Detour Village weather station, the prevailing winds for the research area during the winter months average 9-10 mph out of the West-Southwest for October through December with gusts up to 60 mph, but shift up to the Northwest for January through March at essentially the same speeds (See Figures 12 & 13; NOAA, 1998, 2008).



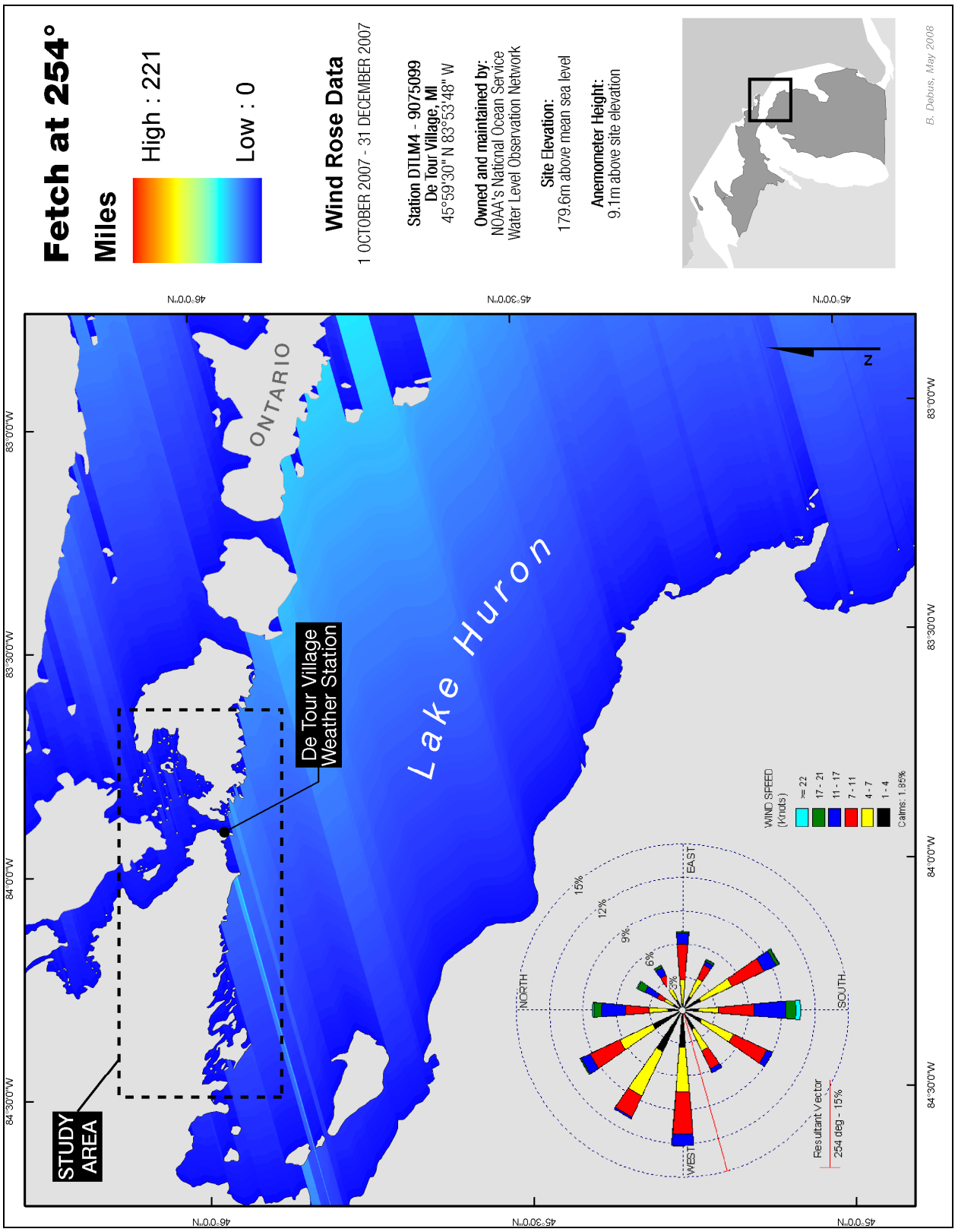

B. Debus, May 2008

Figure 12. Fetch Effect on Research Area during Oct - Dec.

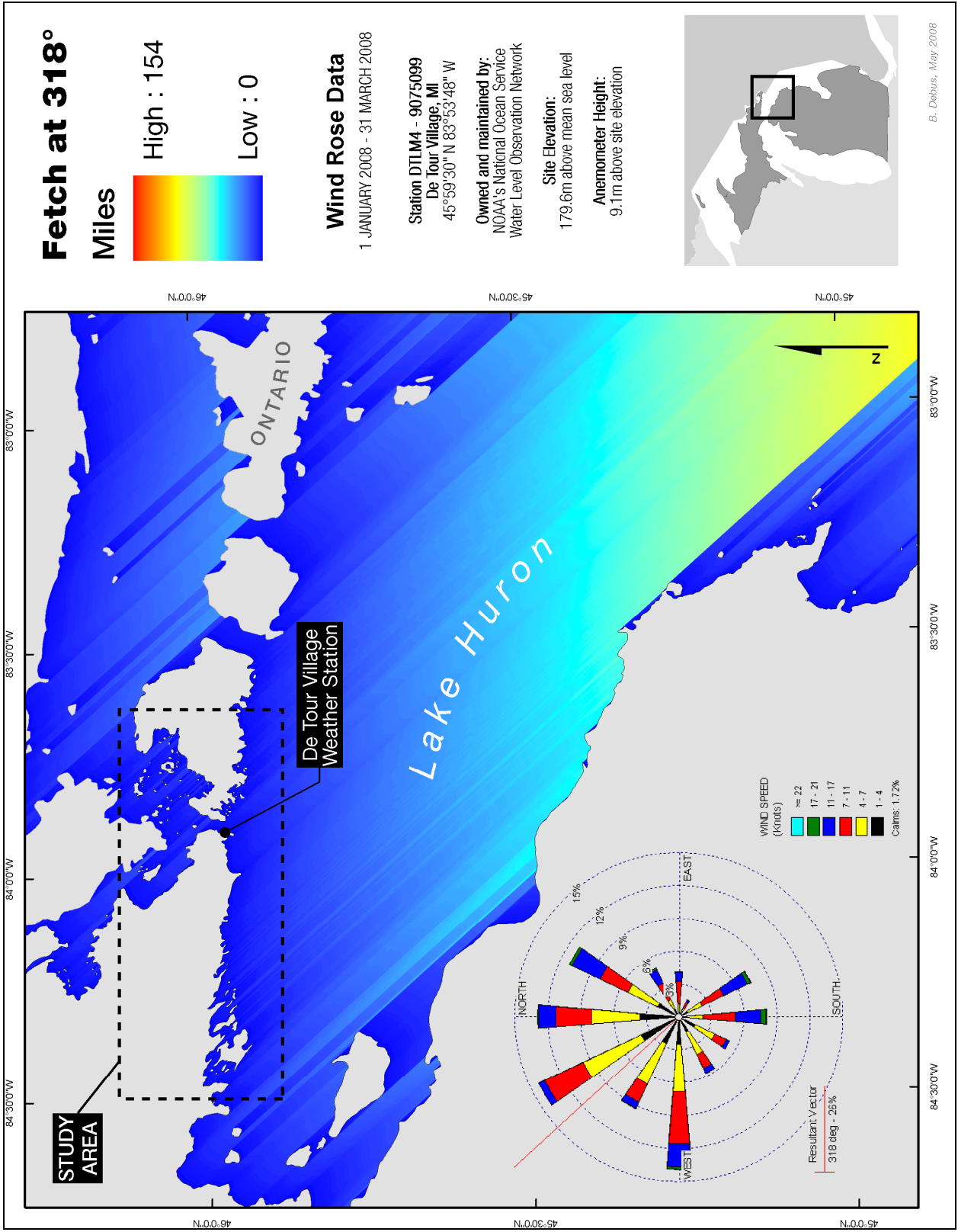
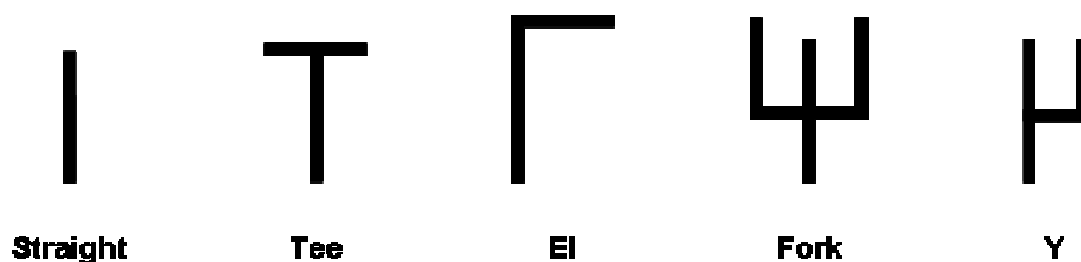

Figure 13. Fetch Effect on Research Area during Jan - Mar.

Figures 12 and 13 show wind roses and fetch exposure for the research area during the fall and winter months, respectively. The wind roses depict the frequency of occurrence for winds in each of the wind direction sectors and the wind speed classes for a specific site, in this case the Detour Village weather buoy, NOAA Data Buoy DTLM4. The wind roses were calculated using WRPLOT, a U.S. EPA-approved Windows utility that generates wind rose statistics and resultant vectors. The prevailing wind resultant vectors, as displayed on the wind roses, were 254° for October to December and 318° for January to March. These prevailing winds were then plotted to display the fetch exposure in the research area using UWWaves Toolbox for ArcGIS 9.0 software. The UWWaves software computes land mass shielding and fetch affect for a steady wind over a semi-enclosed body of water in accordance with the U.S. Army Coastal Engineering Research Center's Shore Protection Manual (1977, p. 3-29). This GIS fetch analysis shows how the bulk of the research area is protected from the greatest winter weather exposure. It also shows that the dock sample has good site exposure sample diversity for protected to moderately exposed sites. However, it also shows that none of the sample docks were located in the most exposed zones of the research area, that is, full exposure to either early or late winter prevailing winds. This was a significant oversight that will need to be addressed in follow on research.

As shown in the Detailed Site GIS Analyses (Appendix 8) and Summary of Crib Dock Configurations (Figure 14), the docks were constructed in a variety of configurations. The **T** shape was the most common dock configuration, but not significantly. In the sample, there were five straight docks, six tees, three ells, two forks, and four **Y** shaped docks. No relationship between configuration and site exposure was evident. The average dock used

seven to eight cribs, which ranged from an average of five cribs for the straight docks to over 14 for the fork configured docks. The gap left at the OHWM ranged from zero to 12 feet.



*Figure 14.* Summary of Crib Dock Configurations.

The mean for all flow gaps was 6.75 feet, but the mode was 11 feet, in keeping with the current, unofficial, but accepted standard of the MDEQ (See Table 4, Crib Dock Sample – Site Data Set).

#### *Crib Design & Construction*

Of the 151 cribs in the sample, 124 were evaluated for height versus base dimensions. The basic rule established by the literature review stated that a crib's height should not exceed either the length or width of the crib's base dimensions. For example, if the crib is 8 feet by 12 feet, it should be no taller than 8 feet, regardless of the crib's orientation within the structure. According to the literature, exceeding this dimensional standard will undermine the crib's stability during winter ice loading. Of the 124 cribs evaluated for height versus base dimensions, 12 were found to be taller than either of their base dimensions. Of these 12, four were interior intermediate cribs in a complex fork configured dock, consisting of 15 cribs, on relatively protected site. When asked about this, the designer and builder contended that the more exposed cribs would provide sufficient protection and support to allow for the dimensional exception. Upon reinspection, the undersized interior cribs were found to be

laterally braced by the more exposed exterior cribs, as the builder had stated. Using slightly undersized interior cribs also allowed for greater littoral flow space within the overall dock design.

Of the other eight excessively tall cribs, one was part of a rebuilt straight dock where the new cribs were set on the previously existing crib that ran the full length of the dock. This is a difficult situation to analyze. The added cribs were built upon the pre-existing crib base. If measured from the pre-existing crib, the new cribs were in accordance with the standard. However, they were not if measured from the lake bottom so that the height included the height of the pre-existing crib. This is more appropriate, because it represents the crib's vertical exposure to winter ice loading. Five were part of two very old, well protected docks in the Hessel harbor. The last two of the excessively tall cribs were the end cribs of a straight configured dock with moderate exposure. The dock was situated on the south shore of an east-facing mainland bay with 7.5 miles of due east fetch exposure. These cribs were clearly at risk. That dock was two years old and had only been exposed to two winters when last checked, so its durability could not be fully evaluated.

Generally, the cribs were constructed in a "log cabin" fashion with the flooring mentioned in the qualitative phase findings. The presence of floors was difficult to confirm in the sample set, because it was unclear if an in-place crib did not have a floor or if the floor was simply not visible due to sedimentation. However, the presence of floors was confirmed in 77% of the cribs. So, it is assumed the rest had floors as well. On 62% of the cribs, the horizontal crib frame timbers were notched in the corners leaving a three- to four-inch gap between the horizontal logs. The other cribs either were built with finished timbers or simply did not notch the logs. In addition to the sides and floor, 60% of the cribs had a vertical

member in each corner for rigidity during construction and placement and to tie into the deck stringers. The larger cribs, those 12 or more feet long, typically had intermediate cross members to protect against the sides bowing when loaded with ballast, but this was not specifically evaluated (See Figure 15). Over 90% of the cribs were constructed with 12-inch timber spikes as the primary fastener used on the corner joints. Of the 20 docks and 151 cribs examined, the only exceptions to this style fastener were portions of Sample Dock #1 and the corner joints on the Drummond Island docks, Sample Docks #9 and #10. These two docks, and one nearby out-of-service dock, were constructed using both the timber spikes and the corner joints through bolted in a manner similar to that called for by Burns in the



*Figure 15.* Oversized Crib Framework with Cross Bracing

literature review. Also, the cribs in these Drummond Island docks had no overlap at the corner joints and solid sides without any gap between levels of the crib construction. This

style of crib construction explains the need for the corner joint bolt design (See Table 5, Crib Dock Sample – Crib Data Set).

### *Dock Superstructure*

For the dock sample, 90% of the decks were between 7.5 and 8.5 feet wide; only a portion of one was less than that; one dock and a portion of two others were wider. Similarly, 90% of the decking consisted of 2" x 6" planking supported by 6" x 6" or 4" x 6" timber stringers. Although one builder mentioned using 5/4" x 6" decking, none was found. The typical arrangement (70%) was three joists on 46" centers. The largest wet gap was 11 feet or more on 55% of the sample docks with three docks having wet gaps of more than 17 feet. Contrary to what was stated by one of the contractors in the qualitative phase, three of the sample docks used 2" joist materials with no apparent ill effects. According to the owner of one of these docks, it had been 20 years since the dock had been redecked. Also of note, many of the deck surfaces on the older commercial decks had been repaired in a haphazard inconsistent manner, leaving an uneven, unsafe walking surface. Treated 2" x 6" lumber costs 60% more than untreated, and none of the lumber used for the dock decks, neither joists nor decking, appeared to be pressure-treated. However, once treated lumber has weathered a few years, it is very difficult to differentiate from untreated lumber. For example, Sample Dock #1 was originally thought to be decked with untreated lumber, but subsequently found to have treated lumber. This was discovered during routine maintenance which required some deck boards to be removed, and their undersides were green, indicating treated lumber. So, the treated versus untreated assessments are questionable. Five docks had permanently installed electrical service, one of which was solar powered, and four had or

were built to accommodate boat houses. None of those with permanently installed electrical service appeared to have ground fault interruption (GFI) protection. The wet gaps under the boat houses averaged 6.2 feet (See Table 6, Crib Dock Sample – Superstructure Data Set).

### *Ground Anchorage*

The vast majority (95%) of the sample docks used driven pilings for ground anchorage. On all but three of the docks with pilings, the pilings were driven taper down. Of note, the three docks with pilings driven butt down were the three sample docks from outside the Les Cheneaux region proper. However, in examining the pilings on all the docks, there was no apparent advantage of one method over the other. The pilings seemed to have equivalent durability and rigidity. The pilings driven taper first did look more attractive than those driven butt first. The one dock without pilings was a well sheltered dock in Cedarville Bay. In place of pilings, the dock simply depended on crib ballast for ground anchorage. The dock's four primary cribs were either 8'x 11' or 8'x 9', which have 180 cubic feet and 228 cubic feet of ballast well capacity, respectively. This is commensurate with the other three docks in the immediate area, which did use pilings. However, the dock without pilings was in a particularly shallow setting, reducing its vulnerability to ice loading. After what appeared to be 15 to 20 years of service, the dock was still straight, square, and solid. So pilings for ground anchorage are not required in all cases.

The piling spacing varied based on the site, the builder, where on the dock the piling was located, and whether pilings had been added subsequent to construction. The average spacing between pilings was 5.4 feet, with four feet as the most common interval. In 70% of the sample docks, some measures were taken to reinforce a dock's most exposed portions



with additional pilings. The techniques noted were 1) reducing the interval as the dock extended into the water in one dock; 2) using very close spacing on exposed dock ends, sometimes as close as 18 inches; 3) installing clusters of three pilings on exposed corners as in seven docks; 4) reinforcing the clusters with cabling laced around the pilings and crib vertical timbers on three docks (Figure 10); and 5) using both close interval spacing and corner clusters (Figures 16 & 17). No advantage of one method over another was detected (See Table 7, Crib Dock Sample – Ground Anchorage Data Set).

### *Quantitative Data Validation*

The data validation for the quantitative phase outlines the steps taken to identify problems with the data collected and ensure valid results. The quantitative data validation consisted of data review and verification followed by analysis of the two internal design threats discussed earlier.

#### *Data review*

The data review consisted of the qualitative steps taken while still in the research area to ensure the quantitative data set was complete and accurate. The primary tool for this review was the investigator's growing experience with the material and the area. By the time the data collection was complete, the investigator had over eight weeks in and around the research area, spread out in various installments over four years. This time in sector allowed for a clear understanding of the subject and the various measurements taken. It also gave the investigator an ability to review data collection records to identify values that were missing, mislabeled, or inconsistent with those from similar sites analyzed at other times during the



*Figure 16.* Dock End Pilings with Close Interval Spacing and Corner Clusters.



*Figure 17.* Dock End Piling Corner Cluster with Cable Reinforcement.

data collection. Identified questionable values were subsequently checked and corrected or validated as appropriate. A key tool for the data review was the extensive photographic records taken during the data collection. The photographs taken of the sample's various docks provided an invaluable tool for verifying notes and measurement records during the data analysis.

#### *Data verification*

The data verification consisted of detailed steps taken during the actual data reduction and analysis to ensure the data entries on the data collection forms were accurate and valid. The key checks included identifying missing values, range checking, and validity checking. Again, the investigator's experience played a key role in identifying when recorded data was out of the expected data range or simply missing. In addition to the photographic records mentioned above, one of the key tools for correcting data errors was the detailed data collection forms, which included redundant data fields. Many data elements were collected in two or three ways in different sections of the data record. So, data inconsistencies were readily apparent during data reduction, and many could be corrected by analyzing other sections of the data collection record. Those oversights or errors that could not be corrected by redundant data collections were pursued during two follow-up data collections, conducted May 11-17 and July 2-4, 2008.

#### *Internal Threat Analysis*

The two internal threats to validity mentioned earlier were the quantitative sample bias and limited sample size. The sample size was limited by the labor intensive nature of

data collection for Direct Measurement research. At best, the investigator was able to analyze two docks a day. Due to the constrained research time window and competing priorities, the sample size was limited to 20 docks. Since the study problem was exploratory in nature, the size of the sample was considered acceptable. However, due to the limited sample size, no population inferences were drawn from the analysis.

The sample bias was driven by the data collection being primarily from mainland access. As a result, the majority of the docks in the quantitative sample were constructed at mainland sites. Specifically, 14 docks of the quantitative sample were located at mainland sites, while six were on islands. Each of the analyses discussed in the quantitative data analysis was conducted for mainland versus island docks. No differences between the two sets were noted with the exception of ground anchorage. The island docks were more likely to have reinforced ground anchorage at the exposed ends of the dock. In looking at the entire analysis as a whole, this is more likely due to the more exposed nature of island sites over mainland sites. So, no threat to data validity was detected by the sample bias of mainland sites over island sites. However, the GIS fetch analysis of sample crib dock siting showed how fall and winter prevailing winds affect the research area. It also showed that none of the sample docks were sited in the most exposed areas, areas that receive direct unimpeded fetch along the prevailing resultant wind vectors during the fall and winter months. Less than 3% of the research area's docks are built in areas that are exposed to this most severe winter fetch and associated wave and ice loading. It is an issue that will need to be considered in subsequent exploration of this topic.

## Integrated Findings

This discussion consists of an integrated data analysis followed by an integrated data validation. The initial discussion will merge the findings from qualitative and quantitative phases with the insights gained from the literature review to produce a coherent set of integrated findings that address the research problem as a whole and each of the research questions. The subsequent discussion will review the data validation measures taken to ensure valid results. These measures are somewhat unique to the mixed methods design used for the study.

### *Integrated Data Analysis*

#### *General.*

The primary reviewing and approving authorities for crib docks, the MDEQ and USACE, are generally opposed to crib docks because of their responsibility for protection of the Great Lakes bottomlands and the inland waterways. They emphasize that excessive occupation of bottomland is detrimental to the ecosystem and contrary to the NREPA Part 325 – Great Lakes Submerged Lands. However, they do regularly approve the construction of crib docks throughout the research area, but without any clearly established standards. In an apparent conflict, the MDNR and the USFS encourage the use of crib-based structures, such as the Brevort Lake project outlined in the literature review. In that project, USFS biologists have been working with local sportsmen to install crib structures into Brevort Lake, near St. Ignace, specifically to enhance sport fish population. The MDNR representatives state that, while there is no definitive research that directly links fish

population to crib-based structures, there is sufficient experience-based data to warrant their use.

Discussions with MDEQ representatives confirmed that there are no standards, norms, or guidelines for granting or denying crib dock construction permits. When asked about this, their response was essentially that the approval standards are “rather informal and not really written down anywhere.” They are not entirely comfortable with this but do not have an alternative at this point. When asked about how they determine if a proposed dock’s design is structurally sound, they essentially depend on the experience of the contractor involved. The MDEQ representatives, both in the UP and Lansing offices, expressed interest in some form of norms or guidelines for acceptable crib dock design standards.

### *Dock Siting*

The two key siting factors identified in the qualitative phase were site exposure and accommodating littoral drift. Failure to accommodate site exposure will result in severe ice damage. Similarly, if not accommodated, littoral drift will erode and undercut the cribs, causing them to tilt and eventually topple. However, if these issues are adequately addressed, a well sited and constructed crib dock will last over 30 years with proper maintenance and periodic redecking. This was confirmed during the quantitative phase in that eight of the sample docks consisted of decks rebuilt on previously existing but still sound foundation cribs. To accommodate the winter weathering, the dock ends were angled to face the greatest fetch; used additional or clustered ground anchor pilings; or used oversized, reinforced cribs to anchor the exposed end of the dock. Of the 20 docks examined, nine were sited with moderate fetch exposure to the Lake Huron weather. Of these nine, only one used

the angled technique, but all nine used some combination of additional pilings, clustered pilings, or larger cribs to anchor the exposed end of the dock. The one dock that used the angled end technique was on Marquette Island, one of the most exposed sites evaluated in the quantitative data set. In addition to angling the dock, the contractor also used additional and clustered pilings across the exposed dock end.

The most common adverse environmental impact noted during the quantitative sample data collection was interference with littoral flow and its effects on the shoreline and local bathymetry. The primary technique for accommodating littoral drift is proper siting of individual cribs to minimize littoral flow obstruction. From an ecosystem perspective, littoral flow is a key concern when considering an application for crib dock construction. For the most part, littoral flow was assured by two features: 1) flow spacing at the OHWM and 2) overall flow spacing within the entire dock structure. The littoral flow just below the OHWM is of particular concern. It is the area with the greatest direct affect on littoral plant and water life. To accommodate the flow area just below the OHWM, the cribs in this area should be sited so that they provide the greatest flow area possible. The qualitative phase found that MDEQ has come to accept that 11 feet is an appropriate trade-off between flow area and dock structural integrity. That is, the base of the last crib, above the OHWM, must be placed so that its lakeward edge is set at the OHWM, and the next crib is placed so that its shoreward edge is 11 feet from the OHWM. From the dock sample, 11 feet was the most common crib flow gap allowed at the OHWM, but two docks in the sample had 15 foot gaps at the OHWM. However, as shown in the literature review, residential structural standards show that a 15 foot gap is quite reasonable using 2”x 10” joists on 16” centers and could be

as much as 18 feet with 2"x 12" joists on 16" centers. This additional span at the OHWM would significantly alleviate a crib dock's interference with the near shoreline littoral flow.

One of the contractors contended that 2-inch structural joist materials would not stand up to the environmental demands of dock applications. However, in contrast to this position, three of the docks in the sample used 2" joist materials without problems. One of those docks had a deck that was 20 years old, according to the owner. Residential deck standards typically call for 2" joist materials and, where bowing is a concern, they call for lateral bracing. The use of 2" joist materials would not only extend the OHWM span gap, it would also significantly increase the amount of overall flow spacing that could be achieved. While pressure-treated 2-inch joists are about 63% more expensive than untreated, this appears a reasonable expense for dramatically increased flow spacing and deck life expectancy.

In overall flow spacing for a dock, the MDEQ currently seeks to maintain 50 percent of the running dock length to be open to littoral flow, but will accept 40 percent. That is if a straight dock extends 100 feet lakeward beyond the OHWM, then 40 feet of the dock length must be unobstructed free flow space. The 40 percent standard will allow for 16'x 8' cribs separated by 11-foot gaps; 16-foot cribs are the standard crib used in more exposed sites and for boat house support. However, as shown above, there is no structural reason the gaps could not be 15 to 18 feet, which would easily allow for 50% or more clear flow spacing. To ensure unobstructed free flow, the crib spacing must be symmetrical in the parallel legs of fork and Y shaped docks. Docks that have adequate free flow spacing demonstrated significantly less littoral flow scouring and sedimentation. Only five of the sample docks were built with 50% free flow crib spacing. The average flow space was 27%. Of the 12 docks with noticeable littoral flow scouring or sediment drift, the free flow spacing ranged



from zero to 30%. The increased flow spacing would also reduce the number of cribs needed to achieve a desired design length, probably negating any additional cost.

### *Crib Design & Construction*

For the most part, the material used for the cribs was a matter of choice and cost. In the research area, cedar was used primarily due to availability. Environmentally approved, pressure treated, milled timbers would probably be stronger and last longer, but would be 3.5 times more costly. In that cedar cribs will last over 30 years, there was marginal benefit to using the more costly timbers. Although some cribs were built with finished timbers and abutted joints, the cribs were typically assembled with lapped, notched corner joints and 12” timber spikes as the primary fastener hardware. The lap joints were up to ten inches from the end of the log; however, the mode for joint placement was four inches from the end. Lag bolt and through bolt reinforced corner connections are used infrequently in the research area but are probably stronger.

The literature review stated that a crib’s height should not exceed either of the base dimensions, length or width. So a common eight-foot crib would be eight square and not taller than eight feet as well. This standard was at times violated for intermediate cribs in complex docks with multiple, laterally interconnected cribs as used in fork and Y shaped docks structures. The ballast used was predominantly 6” to 12” unwashed crushed quarry limestone. The common eight foot square crib, measured corner joint to corner joint, leaves a seven foot ballast compartment, which provides 343 ft<sup>3</sup> for ballast or 10 to 12 ton of rock.

### *Dock Superstructure*

The cribs are usually tied together using 6" x 6" timbers as deck stringers. The stringers are supplanted with intermediate 6" x 6" or 4" x 6" or 2" x 6" stringers on 46" centers to support the decking; the decking is typically 2" x 6" yellow pine planking. This stringer arrangement allowed for noticeable deck flex and far exceeded the deck spacing allowed by residential deck standards. The deck materials are typically not pressure treated, but were often treated with a common wood deck preservative after construction was complete. Use of treated lumber would increase initial deck cost by 60% but would at least double the decking life expectancy, making it a cost effective alternative (WWPI, 2006, p. 4). The crib spacing was normally 11 feet for simple dock area and 7 feet for boathouse foundations. While this was the norm in the research area, the literature review showed that the use of 2" deck joist materials could extend the crib gaps out to 18 feet. As was mentioned earlier, this would dramatically alleviate the interference with littoral flow by maximizing the span at the OHWM and increasing the overall free flow space.

### *Ground Anchorage*

The predominant ground anchorage used throughout the research area was pilings driven taper down, although the taper orientation appeared to be more a matter of taste as opposed to structural advantage. The spacing between pilings was typically four to five feet but ranged from 18" to ten feet. The piling spacing differences was in response to anticipated winter ice loading. The pilings were further apart closer inshore or on the protected dock sides, the sides away from the greatest exposure. The pilings were also closer together at the exposed end of the docks. For the more exposed docks, typically some

technique was used to reinforce the exposed ends. These techniques included very close spacing, sometimes as close as 18” between pilings; clusters of three pilings around exposed crib corners; and lacing cabling between the dock cribs and the pilings. The cable lacing and clustered pilings were less common than simply placing pilings closer together as the dock progressed into more exposed waters.

### *Integrated Data Validation*

The integrated data validation discussion will address the steps taken to assure validity in the design and execution of this mixed methods research study and final analysis of the findings. It will focus on those steps taken across both phases and only summarize those employed within each phase individually, as that has already been presented in detail. The discussion will initially describe how the sample design, data collection, and data review and verification assured valid independent phase specific results. It will then address measures taken during the integrated data analysis and subsequent definition of results and conclusions to assure valid integrated findings as drawn from the findings of phase specific data analyses.

### *Data Collection*

As explained in the study design, to assure independent results between the study’s two phases, very different samples were used for each phase of the study. The sample for the qualitative phase consisted of dock contractors, owners, construction material suppliers from the research area (Figure 3), and government officials with a role in approving or inspecting crib dock construction projects. In all, 39 interviews were conducted with 25 different

respondents for a total of over 30 hours of qualitative data. For the quantitative phase, 20 crib docks were analyzed; each analysis took approximately 2.5 hours, for a total of 50 hours invested in the quantitative data set's data collection. In addition, all follow-up data collection used the same respondents or crib docks used in the initial data collection. The two samples were totally independent, assuring independent findings and well triangulated insights.

The validity of the data collection was also assured by the rigorous design of the data collection instruments. Again, independent data collection instruments were developed for each phase. For the qualitative phase, general interview templates were developed for each type of respondent: contractors, owners, material suppliers, and government officials. These templates were then tailored to meet the specific demands of the respondent. Given the nature of Grounded Theory research, these interview templates evolved as the data collection progressed and the understanding of the issues became more complete. Based on the understanding gained during the initial phase, the quantitative phase data collection instrument was developed and tested. In keeping with the nature of quantitative research design, the instrument was not modified during data collection, but it was supplanted during follow-up data collection. The results of these two phases were triangulated with the corresponding results from the other phase to ensure consistency.

All of this was accomplished primarily because the investigator was willing to spend prolonged time in the field to ensure complete data collection. Between the baseline exploration, the two research phases, and the follow-up, the investigator spent more than ten weeks in the research area. In that time, he conducted interviews, visited dock contractors and owners, analyzed docks, personally worked on dock construction projects, and

temporarily became a part of the local community. This prolonged time in the research area was a key element of the research project in that the area is a small rural community. It was critical for the investigator to immerse himself into the community in order to gain the access necessary for complete, thorough data collection.

### *Data Analysis*

In keeping with Creswell's guidance for a mixed methods study, the data analysis focused on significant results and pursued key themes or issues as they arose. In particular, the issue of undefined and "informal" dock standards in the approval process arose almost immediately in interviews with dock contractors and subsequently confirmed with multiple government officials. In addition, the government officials were receptive to outside assistance in developing and defining acceptable norms for crib dock design and construction standards. Similarly, the limited rigorous research into the ecosystem impacts of crib docks came through as a key theme. When asked about the research on the environmental impact of crib docks, MDEQ representatives stated, "You're probably not going to find anything" and "We pretty much work from observation, experience, and intellectual common sense." These themes and others guided subsequent data collection and analysis efforts.

In addition, the data analysis for both phases used the appropriate data validity standards for the Grounded Theory qualitative and Direct Measurement quantitative research paradigms. In particular, the qualitative phase employed recursive interviewing with multiple respondents to ensure clarity and consistency of the findings. Similarly, the quantitative data collection and reduction included a number of redundant elements as built-in data validity checks. And throughout the data collection, reduction, and analysis,

there was triangulation of phase-specific results with each other and the integrated results. Whenever disconnects were identified, they were pursued and resolved through additional interviews, follow-up quantitative data collection, or expanded literature review.

The data validity was further assured through use of member checking and expert opinions. In the course of the data collection, respondents of their own accord offered to review the results and comment on the findings. As a result, a contractor, an owner, and two government officials were asked to review and comment on the study. In addition, the dissertation committee chair was very familiar with the research problem. He was present in the research area throughout the entire data collection and findings compilation and provided constant critical oversight and numerous rigorous reviews of the compiled findings. Similarly, the balance of the dissertation committee reviewed the work and provided comments based on their expertise. And finally, C. Allen Wortely, an emeritus professor from the University of Wisconsin at Madison, College of Engineering, and a subject matter expert on upper Great Lakes small craft harbors, reviewed the methodology, results, and findings and provided constructive, insightful comments on the project's findings, conclusions, and recommendations.

### Chapter Summary

Chapter 4 presented the findings for the study's qualitative and quantitative phases and then integrated the two sets of findings. The primary data collection for the qualitative phase occurred over four weeks between July 16 and August 13, 2006; the primary quantitative data collection was completed July 26 to August 16, 2007; and follow-up data collection for both phases was done May 10-17 and July 2-4, 2008. The initial phase used

the Grounded Theory research approach with purposive sampling. In all, 39 interviews were conducted: 16 with contractors, 12 with crib dock owners, and 11 with various government officials and building material suppliers. The quantitative phase employed Direct Measurement of a convenience sample of 20 serviceable crib docks including 151 individual cribs. Analysis of these results addressed the problem's broader permit processing issues and crib dock siting, individual crib design, dock superstructure, and ground anchorage issues.

Representatives of both MDEQ and USACE were opposed to crib docks primarily because the docks create a waterway obstacle and occupy Great Lakes bottomland in violation of Michigan's Submerged Lands Act. When asked about research that establishes the ill effects of crib docks on the bottomlands, one of the MDEQ representatives stated, "You're probably not going to find anything," which was confirmed. In contrast, the MDNR and U.S. Forest Service (USFS) encouraged crib-based structures as an effective sport fish habitat enhancement. The MDNR representative said they were always looking for viable options for increasing or enhancing water life habitat; cribs are one of the most effective options; and they generate far more habitat surface area than they consume.

Crib docks cost between \$250 and \$1000 a running foot, because the construction work is done primarily by hand. However, if a dock is well sited, built, and maintained, it will provide well over 30 years of service in a very demanding climate. It is generally agreed that crib docks are the most viable option for the moderately exposed dock sites in the research area, providing a balanced alternative to regional aesthetics, structural durability, and environmental impact. However, the permit standards for crib docks are not defined. One of the MDEQ representatives confirmed this, and when asked about the norms or standards, their response was that the approval standards are "rather informal and not really

written down anywhere.” The MDEQ representatives, both in the UP and Lansing offices, expressed interest in some form of norms or guidelines for acceptable crib dock design standards.

The two key design factors in siting crib docks were protecting against winter ice loading exposure and accommodating littoral drift. Failure to accommodate site exposure will result in severe ice damage. To accommodate the winter weathering on sites with moderate to severe site exposure, the dock ends were angled to face the greatest fetch; have larger, reinforced cribs to anchor the exposed end; or increase the number and frequency of ground anchor pilings. The second factor, littoral drift, will erode and undercut the cribs, causing them to tilt and eventually topple over. For the most part, littoral flow was addressed by 1) flow spacing at the ordinary high water mark (OHWM) and 2) overall flow spacing for the entire dock structure. The gap left at the OHWM ranged from zero to 12 feet. The mean was 6.75 feet, but the mode was 11 feet, in keeping with the current, unofficial accepted standard of the MDEQ. As for overall flow spacing for the entire dock, the MDEQ seeks to maintain 50 percent of the running dock length to be open to littoral flow but will accept 40 percent. Flow spacing of 50% or more is very attainable using 2” x 12” joist and 16-foot flow gaps. The docks with the greatest flow spacing norms showed far less ill effect from littoral flow.

As for crib design and construction, the material used was found to be a matter of choice and cost. In the research area, cedar was the only material used primarily due to availability. Environmentally approved, pressure treated, sized timbers would probably be stronger and last longer but cost 3.5 times more than untreated timbers. The primary fastener used through out the research area was the 12” galvanized timber spike. According to the



literature, a crib's height should not exceed either the base width or length dimensions; exceeding this dimensional standard would undermine the crib's stability during winter ice loading. Of the 124 cribs evaluated for height versus base dimensions, over 90% were found to be no taller than either of their base dimensions, width or length. Once the cribs are constructed and on site, they are floated into place and loaded with ballast until they reach neutral buoyancy. They are then sited and fully loaded with ballast. The ballast rock is brought in from off site and was typically unwashed 6" to 12" crushed quarry limestone; an eight-foot-square crib takes 10 to 12 ton of ballast stone.

As for dock superstructure and ground anchorage findings, over 90% of the dock sample had 8-foot-wide decks, and all but one of the docks in the sample set used driven pilings for ground anchorage. Typically the decking consisted of 2" x 6" planking supported by two 6"x 6" timber stringers with an intermediate 6" x 6" or 4" x 6" or 2" x 6" joist. Contractors contended that 2-inch joists would not stand up to the moisture and weathering, but sample docks using 2-inch joists were found and they were structurally sound. Use of 2-inch joist lumber would allow for greater spans between cribs. It was difficult to determine if the decking materials were pressure treated; one contractor said he rarely used treated decking but did apply a common wood deck preservative after construction. Treated deck lumber was found to cost 60% more than untreated. Since it would last more than twice as long as untreated decking, its use would be cost advantageous. On all but three of the docks with pilings, the pilings were driven taper down. There was no apparent advantage of one method over the other; pilings driven taper first did look more attractive than those driven butt first. The spacing between pilings ranged from 4- to 8-foot centers with an average

spacing of 5.4 feet. The differences in piling spacing was primarily a site design decision in response to anticipated winter ice loading.

The study data validation considered both phases and the integrated findings using detailed sample analysis; iterative and redundant data collection; extensive written and photographic records; findings triangulation between the qualitative and quantitative phases; member checking by selected respondents; peer reviews by the dissertation chair and committee members; and the investigator's experience, which grew as the study progressed and enabled him to identify inconsistent or out-of-range data. The anticipated issues were sample size due to the constrained research area and sample diversity between mainland and island sited docks. After data validation, neither of these issues was a concern. However, two issues were identified during data validation as a result of the findings analysis. In the qualitative phase, sample diversity was found to a problem: for the contractors, half of the interviews were with one respondent; and for the dock owners, a third of the interviews were with one respondent. This in-effect sample weighting was closely monitored in the quantitative phase sample selection and data collection to guard against unintentionally skewing of the findings. The quantitative phase's fetch analysis clearly showed how fall and winter prevailing winds affect the research area. It also showed that none of the quantitative sample docks were sited in areas with direct, unimpeded fetch during the fall and winter months. This is an issue that will need to be addressed in subsequent exploration of this problem.

The findings presented in Chapter 4 provide a complete, balanced data set to draw upon in analyzing the study questions and developing the conclusions. Those conclusions will address the primary research intent, the development of a concise set of crib dock design

approval and construction norms for the northern Lake Huron region. This was a topic often mentioned by crib dock contractors and owners and a topic specifically mentioned by MDEQ representatives. On multiple occasions, they expressed interest in a set of norms they could use as basis for considering crib dock applications for approval. These findings support a limited set of standards, but they will not address all issues identified during the data collection, reduction, and analysis. Chapter 5 will summarize the study and findings, present the conclusions and their limitations, propose crib dock design and construction norms, and identify issues yet to be explored to better resolve crib dock construction standards for the Les Cheneaux and Drummond Island region of Michigan's Lake Huron.

Table 4.1

## Crib Dock Sample - Site Data Set

Crib Dock Sample Site Data Set											
Dock	Mainland vs Island	Shape	Use	# of boat wells	# of cribs rebuilt	Max Fetch direction (magnetic)	Max Fetch distance	Shore contour	Littoral zone	Littoral Contour	Soil type & Notes
1 (Cadogan Pt)	Mainland	L	Private moorage	0	5	160°	direct exposure to Lake Huron	Moderate slope to OHWM	Very gradual decline	Very gradual decline	Shelter very cobbly loam, 0 to 6 percent slopes, stony; Very exposed site; used oversized crib at the end. Evidence of a previous crib undercut and rolled into lake. Older site that is being rebuilt by hand; original site suffered severe scouring.
2 (Fulyard Pt)	Island	Lazy L	Private moorage	0	8	110°	direct exposure to Lake Huron	Gradual slope to OHWM	Very gradual decline	Very gradual decline	Esau-Zela complex, 0 to 3 percent slopes; Significant southerly exposure, relatively new; used angled end to face against expected ice loading. Water depth is 2-4' greater south of dock. Effect of interference with littoral flow is evident in shoreline and water depth.
3 (Fulyard Pt)	Island	Staggered Fork	Private moorage	2	14	110°	direct exposure to Lake Huron	Gradual slope to OHWM	Very gradual decline	Very gradual decline	Esau-Zela complex, 0 to 3 percent slopes; Very exposed site; used multiple pilings at exposed corners. Water depth is 2-4' greater south of dock. Effect of interference with littoral flow is evident in shoreline and water depth.
4 (Fulyard Pt)	Island	Straight	Private moorage	0	5	110°	direct exposure to Lake Huron	Gradual slope to OHWM	Very gradual decline	Very gradual decline	Esau-Zela complex, 0 to 3 percent slopes; Very exposed site; multiple pilings across exposed end. The lake level has dropped to the point the dock is not really useable.
5 (RV Park)	Mainland	T	Temp moorage for RV park residents	5	7	135°	1.5 mi	Sandy bluff seawall bluff down to water	Very gradual decline	Very gradual decline	Shelter very cobbly loam, 0 to 6 percent slopes, stony; Reasonably protected site. Scouring of cribs 5, 6, & 7 has caused them to tilt.
6 (RV Park)	Mainland	T	Temp moorage for RV park residents	8	8	135°	1.5 mi	Sandy bluff seawall bluff down to water	Very gradual decline	Very gradual decline	Shelter very cobbly loam, 0 to 6 percent slopes, stony; Reasonably protected site. Scouring of cribs 4, 5, & 6 has caused them to tilt. Apparent littoral flow effect evidenced by the shoreline change.

Table 4.2

## Crib Dock Data Set - Site Analysis

Crib Dock Sample Site Data Set										
Dock	Mainland vs Island	Shape	Use	# of boat wells	# of cribs	Max Fetch direction (magnetic)	Max Fetch distance	Shore contour	Littoral zone	Soil type & Notes
7 (RV Park East)	Mainland	Y	Private moorage	1	8	135°	1.5 mi	Gradual slope to OHWM	Very gradual decline	Wakeley muck; Well protected site.
8 (RV Park West)	Mainland	Y	Private moorage		5	135°	1.5 mi	Sandy bluff seawall bluff down to water	Very gradual decline	Shelter very cobbly loam, 0 to 6 percent slopes, stony; Reasonably protected site. Scouring of cribs has caused them to tilt.
9 (Drummond)	Island	T	Marina & temp moorage for park guests	16	16	0°	direct exposure to Lake Huron	Crib retained seawall bluff down to water	Very gradual decline	Kalkaska-Ocqueoc complex, 0 to 6 percent slopes; Somewhat protected site.
10 (Drummond)	Island	L	Marina & temp moorage for park guests		12	0°	direct exposure to Lake Huron	Crib retained seawall bluff down to water	Very gradual decline	Kalkaska-Ocqueoc complex, 0 to 6 percent slopes; Somewhat protected site.
11 (Woodlands)	Mainland	Y	Private moorage	1	7	185°	.75 mi	High bank with modest gradual decline to waterline.	Very gradual decline	Shelter very cobbly loam, 6 to 15 percent slopes, stony; Some crib tilting of Crib 4.
12 (Woodlands)	Mainland	Fork	Private moorage	2	15	185°	.75 mi	Gradual slope to OHWM	Very gradual decline	Shelter very cobbly loam, 6 to 15 percent slopes, stony; Too new for littoral effects to be apparent.
13 (Woodlands)	Mainland	Y	Private moorage	1	7	185°	.75 mi	Seawall then gradual slope to OHWM	Very gradual decline	Shelter very cobbly loam, 6 to 15 percent slopes, stony; East side of dock has scouring effect clearly evident.

Table 4.3

## Crib Dock Data Set - Site Analysis

Crib Dock Sample Site Data Set										
Dock	Mainland vs Island	Shape	Use	# of boat wells	# of cribs rebuilt	Max Fetch direction (magnetic)	Max Fetch distance	Shore contour	Littoral zone	Soil type & Notes
14 (Lakeside)	Mainland	Straight	Temp moorage for island residents	0	6	120°	moderated direct exposure to Lake	Gradual slope to OHWM	Very gradual decline	Shelter very cobbly loam, 6 to 15 percent slopes, stony. Minimum evidence of sediment drift.
15 (Lakeside)	Mainland	Straight	Private moorage	0	4	120°	moderated direct exposure to Lake	Gradual slope to OHWM	Very gradual decline	Shelter very cobbly loam, 6 to 15 percent slopes, stony. Minimum evidence of sediment drift.
16 (Crow Pt)	Mainland	Straight	Private moorage	0	5	95°	4 mi	Steep slope to Spring	Gradual decline	Shelter very cobbly loam, 6 to 15 percent slopes, stony.
17 (Hill Is)	Island	Straight	Temp moorage for Coryell Island residents	4	5	120°	moderated direct exposure to Lake Huron	Moderate slope to OHWM	Very gradual decline	Shelter very cobbly loam, 6 to 15 percent slopes, stony. Distinct east to west sediment drift clearly evident.
18 (Sunset Res)	Mainland	Offset T	Marina & temp moorage for resort guests	6	4	240°	3 mi moderate exposure to water	Sandy seawall bluff down to water	Very gradual decline	Shelter very cobbly loam, 0 to 6 percent slopes, stony; Distinct east to west sediment drift clearly evident. The owner said a sheet piling dock was approved, but they choose a crib dock for aesthetics.
19 (Loreli Lodges)	Mainland	Offset T	Marina & temp moorage for resort guests	12	10	240°	3 mi moderate exposure to water	Sandy seawall bluff down to water	Very gradual decline	Shelter very cobbly loam, 0 to 6 percent slopes, stony.
20 (Lakeview Motel)	Mainland	T	Marina & temp moorage for resort guests	10	2	240°	3 mi moderate exposure to water	Sandy seawall bluff down to water	Very gradual decline	Shelter very cobbly loam, 0 to 6 percent slopes, stony. This is a very old dock that one point was completely capped with concrete.

Table 5.1

Crib Dock Sample - Crib Data Set

Deck	Crib #	OHWM (ft)	Crib L & W (ft)	Crib Height (in)	Crib I/W (in)	Ht vs Prev Gap (ft)	Free Flow Space (ft)	Timbers with dock (ft)	Timbers across dock (ft)	Timbers size (in)	Timber vert space (in)	Ballast well (ft) (l-w-d)	Type of Ballast (in to end)	Joint placement style	Joint style	Type of fastener	Fastener per joint	Floor Uprights (y/n)
1 (Cadogan Pt)	1-1	Above 39	8	46	ok	0	18%	8	8	fin 6x6	0	38-7-4	BR	0	S	12" spike	2	yes
	1-2	Below 48	8	69	ok	9		8	8	fin 6x6	0	47-7-5	BR	0	S	12" spike	2	yes
	1-3	Below 18	12	88	ok	10		8	8	fin 6x6	0	17-11-7	BR	0	S	12" spike	2	yes
	1-4	Below 15	7	70	ok	9		16	8	rou 6-8"	6-8"	13-6-5	BR	6-8"	S	12" spike	2	yes - bolt
	1-5	Below 13	7	63	ok	9		13	8	rou 6-8"	6-8"	10-6-5	BR	6-8"	S	12" spike	2	yes - bolt
Comments: 6"x 6" timbers & 12" timber spikes rest cedar logs 4-8" in dia. Crib 1 & 2 use finished 6"x6"x8" timbers assembled in a complex box-like fashion. Crib 3 is most exposed and oversized.																		
2 (Fulyard Pt)	2-1	Above 15	8			9	25%			rou 4-8"	5-7"		QS	4"	N 1-2"	12" spike		yes
	2-2	Below 15	8			10				rou 4-8"	5-7"		QS	4"	N 1-2"	12" spike		yes
	2-3	Below 15	8			10				rou 4-8"	5-7"		QS	4"	N 1-2"	12" spike		yes
	2-4	Below 15	8			10				rou 4-8"	5-7"		QS	4"	N 1-2"	12" spike		yes
	2-5	Below 6	6			0				rou 4-8"	5-7"		QS	4"	N 1-2"	12" spike		yes
	2-6	Below 15	8			0				rou 4-8"	5-7"		QS	4"	N 1-2"	12" spike		yes
	2-7	Below 15	8			8				rou 4-8"	5-7"		QS	4"	N 1-2"	12" spike		yes
	2-8	Below 15	8			10				rou 4-8"	5-7"		QS	4"	N 1-2"	12" spike		yes
Comments: all used cedar logs 4-8" in dia & 12" timber spikes; Crib 2-5: Turning crib to support angled end of dock																		
3 (Fulyard Pt)	3-1	Above 3	8			7?	20%			rou 4-8"	5-7"		QS	4"	N 1-2"	12" spike		yes
	3-2	Above 3	8			14				rou 4-8"	5-7"		QS	4"	N 1-2"	12" spike		yes
	3-3	Above 8	8			14				rou 4-8"	5-7"		QS	4"	N 1-2"	12" spike		yes
	3-4	Above 15	8			14				rou 4-8"	5-7"		QS	4"	N 1-2"	12" spike		yes
	3-5	Above 16	8			10				rou 4-8"	5-7"		QS	4"	N 1-2"	12" spike		yes
	3-6	On 15	8			7				rou 4-8"	5-7"		QS	4"	N 1-2"	12" spike		yes
	3-8	Below 15	8			10				rou 4-8"	5-7"		QS	4"	N 1-2"	12" spike		yes
	3-9	Above 4	3			6				rou 4-8"	5-7"		QS	4"	N 1-2"	12" spike		yes
	3-10	Above 28	4							rou 4-8"	5-7"		QS	4"	N 1-2"	12" spike		yes
	3-11	On 15	8			8				rou 4-8"	5-7"		QS	4"	N 1-2"	12" spike		yes
	3-12	On 16	8			8				rou 4-8"	5-7"		QS	4"	N 1-2"	12" spike		yes
	3-13	Below 16	8			9				rou 4-8"	5-7"		QS	4"	N 1-2"	12" spike		yes
	3-14	Below 16	8			8				rou 4-8"	5-7"		QS	4"	N 1-2"	12" spike		yes
	Comments: all used cedar logs 4-8" in dia & 12" timber spikes																	
4 (Fulyard Pt)	4-1	Above 12	8				15%			rou 4-8"	5-7"		QS	4"	N 1-2"	12" spike		yes
	4-2	Above 20	8			5				rou 4-8"	5-7"		QS	4"	N 1-2"	12" spike		yes
	4-3	Above 12	8			5				rou 4-8"	5-7"		QS	4"	N 1-2"	12" spike		yes
	4-4	Below 20	8			4				rou 4-8"	5-7"		QS	4"	N 1-2"	12" spike		yes
	4-5	Below 15	8			5				rou 4-8"	5-7"		QS	4"	N 1-2"	12" spike		yes
Comments: all used cedar logs 4-8" in dia & 14" timber spikes																		

Table 5.2

Crib Dock Sample - Crib Data Set

Crib Dock Sample Crib Data Set																			
Dock	Crib #	OHWM L & W below	Crib Height (in)	Crib HTvs l/w	Prev Gap (ft)	Free Flow Space	Timbers with dock (ft)	Timbers across dock (ft)	Timbers size (in)	Timber vert space (in)	Ballast well (ft) (l-w-d)	Type of Ballast (in to end)	Joint style	Joint placement	Type of fastener	Fastener per joint	Floor (y/n)	Uprights (y/n)	
5 (RV Park)	5-1	Above 2.2	8	24	ok	9	40%	2.5	8	8-10"	8"	1-6-2	BR	7"	n 2"	12" spike	1	yes	no
	5-2	Above 7.5	8	32	ok	11		7.5	8	8-10"	8"	6-6-2	BR	7"	n 2"	12" spike	1	yes	no
	5-3	Below 8	8	51	ok	12		7.5	8	8-10"	8"	6-6-4	BR	7"	n 2"	12" spike	1	yes	no
	5-4	Below 8	8	64	ok	11		7.5	8	8-10"	8"	6-6-5	BR	7"	n 2"	12" spike	1	yes	no
	5-5	Below 8	8	81	ok	8		7.5	8	8-10"	8"	6-6-7	BR	7"	n 2"	12" spike	1	yes	no
	5-6	Below 8	8	84	ok	8		7.5	8	8-10"	8"	6-6-7	BR	7"	n 2"	12" spike	1	yes	no
	5-7	Below 8	8	88	ok	8		7.5	8	8-10"	8"	6-6-8	BR	7"	n 2"	12" spike	1	yes	no
Comments: all used cedar logs 4-8" in dia; corner connections not notched & 12" timber spikes; used intermediate timbers to retain ballast. Scouring under cribs 5, 6, & 7 has caused them to tilt away from the long leg of the T.																			
6 (RV Park)	6-1	Above 7	8	34	ok	10	51%	2.5	8	8-10"	8"	1-6-2	BR	7"	n 2"	12" spike	1	yes	no
	6-2	Above 7	8	54	ok	14		7.5	8	8-10"	8"	6-6-2	BR	7"	n 2"	12" spike	1	yes	no
	6-3	Below 7	8	64	ok	11		7.5	8	8-10"	8"	6-6-4	BR	7"	n 2"	12" spike	1	yes	no
	6-4	Below 8	8	68	ok	9		7.5	8	8-10"	8"	6-6-5	BR	7"	n 2"	12" spike	1	yes	no
	6-5	Below 8	8	70	ok	9		7.5	8	8-10"	8"	6-6-7	BR	7"	n 2"	12" spike	1	yes	no
	6-6	Below 8	8	70	ok	9		7.5	8	8-10"	8"	6-6-7	BR	7"	n 2"	12" spike	1	yes	no
Comments: all used cedar logs 4-8" in dia; corner connections not notched & 12" timber spikes; used intermediate timbers to retain ballast.																			
7 (RV Park East)	7-1	Above 6	7	34	ok	1	48%	7	6	rou 6"	6"	5.5-4.5-3	6-12"	9	s	12" spike	1-2	no	yes - spike
	7-2	Above 6	7	38	ok	7		7.5	6	rou 6"	6"	5.5-4.5-3	6-12"	9	s	12" spike	1-2	no	yes - spike
	7-3	Above 6	7	41	ok	7		7.5	6	rou 6"	4	5.5-4.5-3	6-12"	7	n 1"	12" spike	1-2	no	yes - spike
	7-4	Above 6	7	41	ok	7		7	6	rou 6"	6	5.5-4.5-3	6-12"	9	n 1"	12" spike	1-2	yes	yes - spike
	7-5	Above 9	7	45	ok	9		9	7.5	rou 8"	6	7.5-6-4	6-12"	9	n 1"	12" spike	1-2	yes	yes - spike
	7-6	Above 11	7	48	ok	7		11	7.5	rou 8"	6	9.5-6-4	6-12"	9	n 1"	12" spike	1-2	yes	yes - spike
	7-7	Above 9	7	53	ok	11		9	7.5	rou 8"	6	7.5-6-4	6-12"	9	n 1"	12" spike	1-2	yes	yes - spike
	7-8	Above 11	7	59	ok	7		11	7.5	rou 8"	6	9.5-6-4	6-12"	9	n 1"	12" spike	1-2	yes	yes - spike
Comments: all used cedar logs 6-10" in dia; corner connections notched & 12" timber spikes.																			



Table 5.3

Crib Dock Sample - Crib Data Set

Deck	Crib #	OHWM (above/ below)	Crib L & W (ft)	Crib Height (in)	HT vs l/w	Prev Gap (ft)	Free Flow Space	Timbers with dock (ft)	Timbers across dock (ft)	Timber size (in)	Timber vert space (in)	Ballast well (ft) (l-w-d)	Type of Ballast	Joint placement (in to end)	Joint style	Type of fastener	Fastener per joint	Floor Uprights (y/n)	Uprights (y/n)	
8 (RV Park West)	8-1	Above	5.5	7.5	55	ok	1.8	8%	5.5	7.5	rou 6-8"	4	4.5-6.5-4	BR	6	n 1"	12" spike	2	yes - spike	yes - spike
	8-2	On	7	8.5	65	ok	8		7	8.5	rou 6-8"	4	6-6.6-5	BR	6	n 1"	12" spike	2	yes - spike	yes - spike
	8-3	Below	7	8.5	74	ok	9		7	8.5	rou 6-8"	4	6-6.6-5	BR	6	n 1"	12" spike	2	yes - spike	yes - spike
	8-4	On	7	8.5	62	ok	11		7	8.5	rou 6-8"	4	6-6.6-5	BR	6	n 1"	12" spike	2	yes - spike	yes - spike
	8-5	Below	7	8.5	66	ok	9		7	8.5	rou 6-8"	4	6-6.6-5	BR	6	n 1"	12" spike	2	yes - spike	yes - spike
Comments: all used cedar logs 4-6" in dia; corner connections notched & 14" timber spikes																				
9 (Drummond Is)	9-1	On	13	8	67	ok	0	0%	13	8	rou 6-8"	0	12-7-5	0-8"	0	\$	12" spike	2	?	no
	9-2	Below	13	8	65	ok	0		13	8	rou 6-8"	0	12-7-5	0-8"	0	\$	12" spike	2	?	no
	9-3	Below	13	8	65	ok	0		13	8	rou 6-8"	0	12-7-5	0-8"	0	\$	12" spike	3	?	no
	9-4	Below	13	8	63	ok	0		13	8	rou 6-8"	0	12-7-5	0-8"	0	\$	12" spike	2	?	no
	9-5	Below	13	8	67	ok	0		13	8	rou 6-8"	0	12-7-5	0-8"	0	\$	12" spike	2	?	no
	9-6	Below	13	8	65	ok	0		13	8	rou 6-8"	0	12-7-5	0-8"	0	\$	12" spike	4	?	no
	9-7	Below	13	8	65	ok	0		13	8	rou 6-8"	0	12-7-5	0-8"	0	\$	12" spike	2	?	no
	9-8	Below	13	8	63	ok	0		13	8	rou 6-8"	0	12-7-5	0-8"	0	\$	12" spike	2	?	no
	9-9	Below	13	8	64	ok	0		13	8	rou 6-8"	0	12-7-5	0-8"	0	\$	12" spike	2	?	no
	9-10	Below	13	8	62	ok	0		13	8	rou 6-8"	0	12-7-5	0-8"	0	\$	12" spike	2	?	no
	9-11	Below	13	8	74	ok	0		13	8	rou 6-8"	0	12-7-6	0-8"	0	\$	12" spike	3	?	no
	9-12	Below	13	8	72	ok	0		13	8	rou 6-8"	0	12-7-6	0-8"	0	\$	12" spike	2	?	no
	9-13	Below	13	8	76	ok	0		13	8	rou 6-8"	0	12-7-6	0-8"	0	\$	12" spike	2	?	no
	9-14	Below	13	8	78	ok	0		13	8	rou 6-8"	0	12-7-6	0-8"	0	\$	12" spike	3	?	no
	9-15	Below	13	8	74	ok	0		13	8	rou 6-8"	0	12-7-6	0-8"	0	\$	12" spike	4	?	no
	9-16	Below	13	8	78	ok	0		13	8	rou 6-8"	0	12-7-6	0-8"	0	\$	12" spike	4	?	no
Comments: all used cedar logs 4-6" in dia; corner connections notched rebar run thru with very little timber overlap. The cribs are butted up against each other creating a single solid oversized crib.																				

Table 5.4

Crib Dock Sample - Crib Data Set

Deck	Crib #	OHWM (above/below)	Crib L&W (ft)	Crib Height (in)	Ht vs l/w	Prev Gap (ft)	Free Flow Space	Timbers with dock (ft)	Timbers across dock (ft)	Timber size (in)	Timber vert space (in)	Ballast well (ft) (l-w-d)	Type of Ballast placement (in to end)	Joint style	Type of fastener	Fastener per joint	Floor (y/n)	Uprights (y/n)	
10 (Drummond Is)	10-1	On	13	8	64	ok	0	0%	13	8	rou 6-8"	0	12-7-5	8"	0	12" spike	2-4	?	no
	10-2	Below	13	8	66	ok	0		13	8	rou 6-8"	0	12-7-5	8"	0	12" spike	2-4	?	no
	10-3	Below	13	8	66	ok	0		13	8	rou 6-8"	0	12-7-5	8"	0	12" spike	2-4	?	no
	10-4	Below	13	8	69	ok	0		13	8	rou 6-8"	0	12-7-5	8"	0	12" spike	2-4	?	no
	10-5	Below	13	8	70	ok	0		13	8	rou 6-8"	0	12-7-5	8"	0	12" spike	2-4	?	no
	10-6	Below	13	8	74	ok	0		13	8	rou 6-8"	0	12-7-5	8"	0	12" spike	2-4	?	no
	10-7	Below	13	8	75	ok	0		13	8	rou 6-8"	0	12-7-5	8"	0	12" spike	2-4	?	no
	10-8	Below	13	8	83	ok	0		13	8	rou 6-8"	0	12-7-5	8"	0	12" spike	2-4	?	no
	10-9	Below	13	8	83	ok	0		13	8	rou 6-8"	0	12-7-5	8"	0	12" spike	2-4	?	no
	10-10	Below	13	8	83	ok	0		13	8	rou 6-8"	0	12-7-5	8"	0	12" spike	2-4	?	no
	10-11	Below	13	8	75	ok	0		13	8	rou 6-8"	0	12-7-6	8"	0	12" spike	2-4	?	no
	10-12	Below	13	8	77	ok	0		13	8	rou 6-8"	0	12-7-6	8"	0	12" spike	2-4	?	no
Comments: all used cedar logs 4-6" in dia, corner connections notched rebar run thru with very little timber overlap.																			
11 (Woodlands)	11-1	Above	4	8	22	ok	10	50%		4-8"	5-7"	5-7"	4"	notch	12" spike				
	11-2	Above	15	8	53	ok	18			4-8"	5-7"	5-7"	4"	notch	12" spike				
	11-3	Below	15	8	64	ok	11			4-8"	5-7"	5-7"	4"	notch	12" spike				
	11-4	Below	15	8	87	ok	11			4-8"	5-7"	5-7"	4"	notch	12" spike				
	11-5	Below	15	8	87	ok	11			4-8"	5-7"	5-7"	4"	notch	12" spike				
	11-6	Below	15	8	64	ok	9			4-8"	5-7"	5-7"	4"	notch	12" spike				
	11-7	Below	17	7	57	ok	8			4-8"	5-7"	5-7"	4"	notch	12" spike				
Comments: all used cedar logs 4-8" in dia, corner connections notched & 12" timber spikes.																			

Table 5.5

Crib Dock Sample - Crib Data Set

Deck	Crib #	O/H/W (above/below)	Crib L & W (ft)	Crib Height (in)	Ht vs l/w	Prev Gap (ft)	Free Flow Space	Timbers with dock (ft)	Timbers across dock (ft)	Timber size (in)	Timber vert space (in)	Ballast well (ft) (l-w-d)	Type of Ballast	Joint placement (in to end)	Joint style	Type of fastener	Fastener per joint	Floor (Y/N)	Uprights (Y/N)
12 (Woodlands)	12-1	Above	7 8	29	ok	17	48%			4-8"	5-7"	QS	QS	4"	notch	12" spike		yes	yes-spike
	12-2	Above	7 8	28	ok	11				4-8"	5-7"	QS	QS	4"	notch	12" spike		yes	yes-spike
	12-3	Below	7 8	40	ok	11				4-8"	5-7"	QS	QS	4"	notch	12" spike		yes	yes-spike
	12-4	Below	15 8	53	ok	11				4-8"	5-7"	QS	QS	4"	notch	12" spike		yes	yes-spike
	12-5	Below	13 7	69	ok	11				4-8"	5-7"	QS	QS	4"	notch	12" spike		yes	yes-spike
	12-6	Below	13 7	75	ok	4				4-8"	5-7"	QS	QS	4"	notch	12" spike		yes	yes-spike
	12-7	Below	13 7	99	NO	6				4-8"	5-7"	QS	QS	4"	notch	12" spike		yes	yes-spike
	12-8	Below	13 4	69	NO	11				4-8"	5-7"	QS	QS	4"	notch	12" spike		yes	yes-spike
	12-9	Below	13 6	69	ok	11				4-8"	5-7"	QS	QS	4"	notch	12" spike		yes	yes-spike
	12-10	Below	13 6	64	ok	4				4-8"	5-7"	QS	QS	4"	notch	12" spike		yes	yes-spike
	12-11	Below	13 6	97	NO	6				4-8"	5-7"	QS	QS	4"	notch	12" spike		yes	yes-spike
	12-12	Below	13 4	69	NO	11				4-8"	5-7"	QS	QS	4"	notch	12" spike		yes	yes-spike
	12-13	Below	13 7	69	ok	11				4-8"	5-7"	QS	QS	4"	notch	12" spike		yes	yes-spike
	12-14	Below	13 7	75	ok	4				4-8"	5-7"	QS	QS	4"	notch	12" spike		yes	yes-spike
	12-15	Below	13 7	99	ok	6				4-8"	5-7"	QS	QS	4"	notch	12" spike		yes	yes-spike
Comments: all used cedar logs 4-8" in dia, corner connections notched & 12" timber spikes.																			
13 (Woodlands)	13-1	Above	8 6	19	ok	11	39%			6x6					smooth	12" spike			
	13-2	Above	8 6	28	ok	9				6x6					smooth	12" spike			
	13-3	On	8 6	47	ok	12				6x6					smooth	12" spike			
	13-4	Below	21 8	72	ok	7				6x6					smooth	12" spike			
	13-5	Below	19 8	78	ok	1				6x6					smooth	12" spike			
	13-6	Below	20 8	72	ok	7				6x6					smooth	12" spike			
	13-7	Below	20 8	87	ok	1				6x6					smooth	12" spike			
Comments: Rebuilt dock with finished 6x6 timber cribs placed on pre-existing cribs. Cribs 13-4/5 & 13-6/7 are abutted tight cribs under boathouse.																			

Table 5.6

Crib Dock Sample - Crib Data Set

Dock	Crib OHWM # (above/below)	Crib L&W (ft)	Crib Height (in)	Crib l/w (in)	Htvs l/w (ft)	Prev Gap (ft)	Free Flow Space (ft)	Timbers with dock (ft)	Timbers across dock (ft)	Timber size (in)	Timber vert space (in)	Ballast well (ft) (l-w-d)	Type of Ballast	Joint placement (in to end)	Joint style	Type of fastener	Fastener per joint	Floor (y/n)	Uprights (y/n)	
14 (Lakeside)	14-1	On	13	11	54	ok	0	0%	12.5	10.5	rou 8	2'	10.5-8.5-4 8"	BR 6	8"	n 1"	12" spike	3	y	y - spike
	14-2	Below	8	11	61	ok	0	8	10.5	10"	rou 8	2'	6-8.5-5 8"	BR 6	8"	n 1"	12" spike	3	y	y - spike
	14-3	Below	8	11	63	ok	0	7.5	10.5	10"	rou 8	2'	5.5-8.5-5 8"	BR 6	8"	n 1"	12" spike	3	y	y - spike
	14-4	Below	8	11	67	ok	0	8	10.5	10"	rou 8	2'	6-8.5-5 8"	BR 6	8"	n 1"	12" spike	3	y	y - spike
	14-5	Below	8	11	74	ok	0	8	10.5	10"	rou 8	2'	6-8.5-5 8"	BR 6	8"	n 1"	12" spike	3	y	y - spike
	14-6	Below	8	11	87	ok	0	11.5	10.5	10"	rou 8	2'	9.5-8.8-8 8"	BR 6	8"	n 1"	12" spike	3	y	y - spike
Comments: all used cedar logs 6-8" in dia, corner connections notched & 12" timber spikes, tightly abuted with no flow gap.																				
15 (Lakeside)	15-1	Above	7	7	31	ok	13	25%	7	7	rou 4	3	6-6-3 BR	BR 10	n 1"	12" spike	2-3	y	y - spike	
	15-2	On	16	7	61	ok	11	15.5	7	10"	rou 6	5	14-6-4 BR	BR 10	n 2"	12" spike	2-3	y	y - spike	
	15-3	Below	16	7	73	ok	4	15.5	7	10"	rou 6	5	14-6-6.5 BR	BR 10	n 2"	12" spike	2-3	y	y - spike	
	15-4	Below	16	7	88	NO	4	16	7	10"	rou 6	5	14-6-7 BR	BR 10	n 2"	12" spike	2-3	y	y - spike	
	Comments: rough cedar timbers																			
16 (Crow Pt)	16-1	Above	8	8	63	ok	10	39%	8	8	rou 6	3	6-6-5-3 QS	QS 6	smooth	12" spike		y	y - spike	
	16-2	Below	8	8	82	ok	7		8	8	rou 6	3	6-6-5-3 QS	QS 6	smooth	12" spike		y	y - spike	
	16-3	Below	15	8	96	ok	7		8	8	rou 6	3	6-6-5-3 QS	QS 6	smooth	12" spike		y	y - spike	
	16-4	Below	15	8	109	NO	7		8	8	rou 6	3	6-6-5-3 QS	QS 6	smooth	12" spike		y	y - spike	
	16-5	Below	15	8	126	NO	2		8	8	rou 6	3	6-6-5-3 QS	QS 6	smooth	12" spike		y	y - spike	
Comments: all used cedar logs 6-10" in dia, corner connections not notched & 12" timber spikes. The crib ballast wells are only 2/3 full.																				
17 (Hill Is)	17-1	Above	8	8	29	ok	0	42%	8	8	rou 6	3	6-6-5-3 QS	QS 6	n 2-3"	12" spike	1-2	y	y - spike	
	17-2	Above	8	8	31	ok	11		8	8	rou 6	3	6-6-5-3 QS	QS 6	n 2-3"	12" spike	1-2	y	y - spike	
	17-3	Above	8	8	48	ok	11		8	8	rou 6	3	6-6-5-3 QS	QS 6	n 2-3"	12" spike	1-2	y	y - spike	
	17-4	Below	15	8	71	ok	11		15	8	rou 6	3	13.5-6.5-5 QS	QS 6	n 2-3"	12" spike	1-2	y	y - spike	
	17-5	Below	15	8	103	ok	8		15	8	rou 6	3	13.5-6.5-8 QS	QS 6	n 2-3"	12" spike	1-2	y	y - spike	
Comments: all used cedar logs 6-11" in dia, corner connections notched & 12" timber spikes.																				

Table 5.7

Crib Dock Sample - Crib Data Set

Crib Dock Sample Crib Data Set																			
Dock	Crib #	OHWM (above/below)	Crib L & W (ft)	Crib Height (in)	Crib l/w	Ht vs l/w Gap (ft)	Prev Flow Space (ft)	Timbers with dock (ft)	Timbers across dock (ft)	Timbers size (in)	Timber vert space (in)	Ballast well (ft)	Type of Ballast	Joint placement (in to end)	Joint style	Type of fastener	Fastener per joint	Floor (y/n)	Uprights (y/n)
18 (Sunset Resort)	18-1	Below	8	8	65	ok	12	15%	7.5	8	4-8"	6-7-4	QS 6	8"	s	12" spike	2-3	y	y - spike
	18-2	Below	15	8	67	ok	10	15	8	8"	4-8"	13-7-5	QS 6	8"	s	12" spike	2-3	y	y - spike
	18-3	Below	16	8	67	ok	10	16	8	8"	4-8"	14-7-5	QS 6	8"	s	12" spike	2-3	y	y - spike
	18-4	Below	17	8	67	ok	10	17	8	8"	4-8"	15-7-5	QS 6	8"	s	12" spike	2-3	y	y - spike
Comments: all used cedar logs 6-10" in dia, corner connections not notched & 14" timber spikes.																			
19 (Lorell Lodges)	19-1	Below	32	8	95	NO	0	27%	15.5	7.5	4"	14-6-7	QS	8"	n2"	12" spike	2-3	y	y - spike
	19-2	Below	16	8	95	NO	0	15.5	7.5	8"	4"	14-6-7	QS	8"	N2"	12" spike	2-3	Y	y - spike
	19-3	Below	18	8	95	NO	0	32	8	8x8	8"	30-6-7	QS	0	s	12" spike	3	y	no
	19-4	Below	41	8	95	NO	7	40.5	7.5	8x8	8"	39-6-7	conc	0	s	12" spike	3	y	no
	19-5	Below	31	8	80	ok	8	31	7.5	8x8	8"	29-6-6	BR & conc	0	s	12" spike	3	y	no
	19-6	Below	16	8	79	ok	7	15.5	7.5	8x8	8"	14-6-6	conc	0	s	12" spike	3	y	no
	19-7	Below	16	8	79	ok	6	16	7.5	8x8	8"	14-6-6	conc	0	s	12" spike	3	y	no
	19-8	Below	16	8	77	ok	7	16	7.5	8x8	8"	14-6-5	BR & conc	0	s	12" spike	3	y	no
	19-9	Below	16	8	74	ok	7	16	7.5	8x8	8"	14-6-5	BR & conc	0	s	12" spike	3	y	no
	19-10	Above	15	8	69	ok	0	15	7.5	8x8	8"	13.5-6-4	conc	0	s	12" spike	3	y	no
Comments: original cribs used cedar logs 8-10" in dia, rebuilt with 8"x 8" timbers, 12" timber spikes, used local dredge spoil for ballast. Owner says cribs 1 & 2 were added by B. Dunn in 1990.																			
20 (Lakeview Motel)	20-1	Below	19	8	58	ok	8	6%	12	8	6"	18-7-4	BR	0	s	12" spike	3	y	no
	20-2	Below	86	8	90	NO	6	12	9	rou 10"	6"	84-7-6	BR	8"	n2"	12" spike	3	y	y - spike
Comments: all used cedar logs 6-10" in dia, corner connections not notched & 12" timber spikes.																			

Table 6.1

## Crib Dock Sample - Superstructure Data Set

Crib Dock Sample Superstructure Data Set										
Dock	Total Running Length (ft)	Deck Width (ft)	Largest Wet Gap (ft)	Gap at OWHM (est)	Deck Joists/Stringers (material & size)	Joist/Stringer Layout (# & spacing)	Joists/Stringers (length & overlap)	Treadway/Deck Material (size - treated)	Surface Treatment (used/not)	Notes
1 (Cadogan Pt)	172	8/12/8	10	9	6"x 6" timbers 2x6 pine	3-48" ctrs 48" ctrs 16" ctrs 7-	0	2"x 6" planking	none	
2 (Fulyard Pt)	184	8	10	10	6"x 6" timbers	3-48" ctrs	0 with gussets	2"x 6" planking with edge trim	used	Solar cell with battery pack to drive lights.
3 (Fulyard Pt)	299	8	10	0	6"x 6" timbers	3-48" ctrs	0 with gussets	2"x 6" planking	?	Design OWHM gap was 14" before lake level dropped.
4 (Fulyard Pt)	115	8	5	4	6"x 6" timbers	3-48" ctrs	0 with gussets	2"x 6" planking	?	Design OWHM gap was 16" before lake level dropped.
5 (RV Park)	131	8	15	12	6"x 6" (outside) & 4"x 6" (center) timbers	4-26" ctrs	0 with bolted gussets	2"x 6" planking	none	3 stringers
6 (RV Park)	117	8	15	11	6"x 6" (outside) & 4"x 6" (center) timbers	3-38" ctrs 45" ctrs	0 with bolted gussets	2"x 6" planking	none	3 stringers
7 (RV Park East)	176	6/7.5	10	10	4"x 6" timbers	3-38" ctrs 45" ctrs	butted	2"x 6" planking	none	Boathouse; 7' spacing under boat house.
8 (RV Park West)	88	7.5/6.5	11	9	4"x 6" timbers			2"x 6" planking		Gap was once 18" on shore; remains of a boathouse evident; 9' Multiple floating dock fingers attached.
9 (Drummond)	236	8	0	0	4"x 6" timbers	3-48" ctrs	butted	2"x 6" planking	none	
10 (Drummond)	193	8	0	0	4"x 6" timbers	3-48" ctrs	butted	2"x 6" planking	none	
11 (Woodlands)	159	8	11	11	6"x 6" timbers	3-48" ctrs	0 with gussets	2"x 6" planking		Gap was once 18" on shore; one spudded attached dock finger. Dock is 20 yrs old and still in very good shape.

Table 6.2

## Crib Dock Sample - Superstructure Data Set

Crib Dock Sample Superstructure Data Set										
Dock	Total Running Length	Deck Width (ft)	Largest Wet Gap	Gap at OWHM (est)	Deck Joists/Stringers (material & size)	Joist/Stringer Layout (# & spacing)	Joists/Stringers (length & overlap)	Treadway/Deck Material (size - treated)	Surface Treatment (used/not)	Notes
12 (Woodlands)	268	7.5	11	11	6"x 6" timbers	3-45" ctrs	0 with gussets	2"x 6" planking		Largest gap in the fork was 5"; this dock appears to be built to accommodate a boat house at a later date.
13 (Woodlands)	152	8	9	11	6"x 6" timbers			2"x 6" planking		2' between cribs under boat house walls; boat house with asbestos shingle roof, elect run, & 1 spudded finger.
14 (Lakeside)	58	10.5	0	0	6"x 6" timbers alternated with 2x6s	4-6x6 2x6 20" ctrs	3- 6x6 abutted 2"x6 overlapped 6"	2"x 10" planking	none	This dock use 2x6 joists and they have lasted.
15 (Lakeside)	85	7	4	11	6"x 6" timbers	3-6x6 on 42" ctrs	abutted	2"x 6" planking	none	13' gap on shore.
16 (Crow Pt)	84	8	7	8	6"x 6" timbers	3-6x6 on 42" ctrs	abutted	2"x 6" planking	none	10' gap on shore. Permanent electricity & dock lighting
17 (Hill Is)	93	8	8	11	6"x 6" timbers	3-6x6 on 45" ctrs	abutted	2"x 6" planking	none	Permanent electricity & dock lighting
18 (Sunset Res)	194	8	10	0	6"x 6" timbers (3)	3-45" ctrs	abutted	2"x 6" planking	none	Permanent electricity & dock lighting
19 (Lorell Lodges)	261	7.5	8	7	6"x 6" timbers (3)	3-42" ctrs	abutted	2"x 6" planking	none	Permanent electricity & dock lighting
20 (Lakeview Motel)	333	8/9	8	0	4"x 6" timbers (3) and (2) 2x6s on top of T	3-46" ctrs 26" ctrs	5- abutted	Mixed 2"x 4"/6" 7/8"	none	Permanent electricity & dock lighting

Table 7.1

Crib Dock Sample - Ground Anchorage Data Set

Crib Dock Sample Ground Anchor Data Set								
Dock	Type	Piling #	Exposed end size (in)	Orientation	Spacing (ft from prev)	Reinforced (none/how)	Notes & Observations	
1 (Cadogan Pt)	Piling	1	5	smooth	2	n		
		2	5	smooth	49	n		
		3	5	smooth	11	n		
		4	6x6	smooth	6	n	Attached to crib with spikes	
		5	6x6	smooth	6	n	Attached to crib with spikes	
		6	6x6	smooth	6	n	Attached to crib with spikes	
		7	6x6	smooth	6	n	Attached to crib with spikes	
		8	6x6	smooth	6	n	Attached to crib with spikes	
		9					n	No pilings on cribs 3, 4, 5
		10	6x6	smooth	6	n	Attached to crib with spikes	
		11	6x6	smooth	6	n	Attached to crib with spikes	
		12	6x6	smooth	6	n	Attached to crib with spikes	
		13	6x6	smooth	6	n	Attached to crib with spikes	
		14	6x6	smooth	6	n	Attached to crib with spikes	
		15	6x6	smooth	6	n	Attached to crib with spikes	
		16	6x6	smooth	6	n	Attached to crib with spikes	
		17	6x6	smooth	6	n	Attached to crib with spikes	
		18	6x6	smooth	12	n	Attached to crib with spikes	
		19	6x6	smooth	6	n	Attached to crib with spikes	
		20	6x6	smooth	6	n	Attached to crib with spikes	
		21	6x6	smooth	6	n	Attached to crib with spikes	
		22	6x6	smooth	6	n	Attached to crib with spikes	
		23	6x6	smooth	6	n	Attached to crib with spikes	
		24	6x6	smooth	6	n	Attached to crib with spikes	
		25	6x6	smooth	6	n	Attached to crib with spikes	
2 (Fulyard Pt)	Piling			Taper down	3'	n	2' to the end 5 pilings across exposed end; clusters of 3 at exposed corners.	
3 (Fulyard Pt)	Piling			Taper down	4'	n	3 pilings at the exposed corners multiple pilings across exposed end; essentially lan dlocked	
4 (Fulyard Pt)	Piling			Taper down	4'	n	Cluster of 3 on all 4 exposed corners with cabling to reinforce	
5 (RV Park)	Piling			Taper down	4' lakeside & 10' backside	n	Cluster of 3 on all 4 exposed corners with cabling to reinforce	
6 (RV Park)	Piling			Taper down	4' lakeside & 10' backside	n	Cluster of 3 on all 4 exposed corners with cabling to reinforce	



Table 7.2

## Crib Dock Sample - Ground Anchorage Data Set

		Crib Dock Sample Ground Anchor Data Set						
7 (RV Park East)	none							An essentially landlocked dock; used oversized cribs for primary ground anchorage.
8 (RV Park West)	Limited light weight pilings	1	6	smooth	18'	n		
		2	6	smooth	5.5	n		
		3	6	smooth	8.5	n		
		4	6	smooth	11	n		
		5	6	smooth	8.5	n		
		6	6	smooth	7	n		
		7	6	smooth	8.5	n		
		8	6	smooth	7	n		
		9	6	smooth	8.5	n		
		10	6	smooth	7	n		
		11	6	smooth	8.5	n		
		12	6	smooth	11	n		
		13	6	smooth	8.5	n		
		14	6	smooth	7	n		
		15	6	smooth	8.5	n		
		16	6	smooth	7	n		
		17	6	smooth	8.5	n		
		18	6	smooth	7	n		
		19	6	smooth	8.5	n		
		20	6	smooth	5.5	n		
9 (Drummond)	Limited light weight pilings		5	smooth	7	n	none on exposed, lakeside top of T	
10 (Drummond)	Limited light weight pilings		4x6	smooth	6	n	only along the sides of the long leg of T; none on either side of the top of T	
11 (Woodlands)	Piling			Taper down	4'			
12 (Woodlands)	Piling			Taper down	4'		20" centers on dock ends for reinforcement.	
13 (Woodlands)	Piling			Taper down	5'			

Table 7.3

Crib Dock Sample - Ground Anchorage Data Set

Crib Dock Sample Ground Anchor Data Set						
14 (Lakeside)	Piling	1	8	butt up/taper down	8	n
		2	8	butt up/taper down	8	n
		3	8	butt up/taper down	8	n
		4	8	butt up/taper down	8	n
		5	8	butt up/taper down	8	n
		6	8	butt up/taper down	8	n
		7	8	butt up/taper down	2	n
		8	8	butt up/taper down	1	n
		9	8	butt up/taper down	1	n
		10	8	butt up/taper down	3	n
		11	8	butt up/taper down	4	n
		12	8	butt up/taper down	3	n
		13	8	butt up/taper down	1	n
		14	8	butt up/taper down	1	n
		15	8	butt up/taper down	2	n
		16	8	butt up/taper down	8	n
		17	8	butt up/taper down	8	n
		18	8	butt up/taper down	8	n
		19	8	butt up/taper down	8	n
		20	8	butt up/taper down	8	n
		21	8	butt up/taper down	8	n

3' centers across the end.

Pilings 7, 8, 9 are a corner cluster w/o cabling.

Pilings across the end are closer.

Pilings 12, 13, 14 are a corner cluster w/o cabling.

Table 7.4

Crib Dock Sample - Ground Anchorage Data Set

		Crib Dock Sample Ground Anchor Data Set					
15 (Lakeside)	Piling	1	6	smooth	24	3' centers across the end.	
		2	6	smooth	9		
		3	8	butt up/taper down	7		
		4	8	butt up/taper down	7		
		5	8	butt up/taper down	8		
		6	8	butt up/taper down	8		
		7	8	butt up/taper down	7		
		8	8	butt up/taper down	8		
		9	8	butt up/taper down	3		
		10	8	butt up/taper down	3		
		11	8	butt up/taper down	3		11/12/13 are a corner cluster
		12	8	butt up/taper down	1		
		13	8	butt up/taper down	1		
		14	8	butt up/taper down	2		
		15	8	butt up/taper down	2		
		16	8	butt up/taper down	2		
		17	8	butt up/taper down	2		17/18/19 are a corner cluster
		18	8	butt up/taper down	1		
		19	8	butt up/taper down	6		
		20	8	butt up/taper down	2		
		21	8	butt up/taper down	4		
		22	8	butt up/taper down	4		
		23	8	butt up/taper down	3		
		24	8	butt up/taper down	8		
		25	8	butt up/taper down	8		
		26	8	butt up/taper down	8		
		27	6	smooth	8		
		28	6	smooth	7		18" centers across the end; triples on the corners.
16 (Crow Pt)	Piling		Taper down	7'			

Table 7.5

Crib Dock Sample - Ground Anchorage Data Set

17 (Hill Is)		Crib Dock Sample Ground Anchor Data Set		
Piling	1	10	butt up/taper down	4'
	2	10	butt up/taper down	4'
	3	10	butt up/taper down	4'
	4	10	butt up/taper down	4'
	5	10	butt up/taper down	4'
	6	10	butt up/taper down	4'
	7	10	butt up/taper down	4'
	8	10	butt up/taper down	4'
	9	10	butt up/taper down	4'
	10	10	butt up/taper down	4'
	11	10	butt up/taper down	4'
	12	10	butt up/taper down	1
	13	10	butt up/taper down	1
	14	10	butt up/taper down	3
	15	10	butt up/taper down	3
	16	10	butt up/taper down	1
	17	10	butt up/taper down	1
	18	10	butt up/taper down	4'
	19	10	butt up/taper down	4'
	20	10	butt up/taper down	4'
	21	10	butt up/taper down	4'
	22	10	butt up/taper down	4'
	23	10	butt up/taper down	4'
	24	10	butt up/taper down	4'
	25	10	butt up/taper down	4'
	26	10	butt up/taper down	4'
	27	10	butt up/taper down	4'
	28	10	butt up/taper down	4'
	29	10	butt up/taper down	4'
	30	10	butt up/taper down	4'

triples on the comers with cabling.

12/13/14 are a comer cluster with cabling

Close interval across the end

16/17/18 are a comer cluster with cabling

Table 7.6

Crib Dock Sample - Ground Anchorage Data Set

		Crib Dock Sample Ground Anchor Data Set		
18 (Sunset Res)	Piling	1	10	butts up/taper down
		2	10	butts up/taper down
		3	10	butts up/taper down
		4	10	butts up/taper down
		5	10	butts up/taper down
		6	10	butts up/taper down
		7	10	butts up/taper down
		8	10	butts up/taper down
		9	10	butts up/taper down
		10	10	butts up/taper down
		11	10	butts up/taper down
		12	10	butts up/taper down
		13	10	butts up/taper down
		14	10	butts up/taper down
		15	10	butts up/taper down
		16	10	butts up/taper down
		17	10	butts up/taper down
		18	10	butts up/taper down
		19	10	butts up/taper down
	19 (Lorell Lodges)	Piling	20	10
		21	10	butts up/taper down
		22	10	butts up/taper down
		23	10	butts up/taper down
		24	10	butts up/taper down
		25	10	butts up/taper down
		26	10	butts up/taper down
		27	10	butts up/taper down
		28	10	butts up/taper down
		29	10	butts up/taper down
20 (Lakeview Motel)	Piling	30	10	butts up/taper down
	Piling	89	8"	butts up/taper down
			8-10"	butts up/taper down

triples on all 4 corners

5/6/7 are a corner cluster w/o cabling

20/21/22 are a corner cluster w/o cabling

Clusters of 3 w/o cabling on all 4 corners.  
Clusters of 3 w/o cabling on all 4 corners.

## CHAPTER 5

### CONCLUSIONS & RECOMMENDATIONS

This chapter presents a summary of the first four chapters: the introduction, literature review, methodology, and findings. Based on that information, the chapter then presents the conclusions drawn from the findings, identifies the limitations of those conclusions, and makes recommendations based on this study.

#### Summary of Chapters 1- 4

##### *Introduction*

The first chapter provided an introduction to the problem, its general setting, and the research objective and questions. It also outlined the study's major components, as well as the delimitations, assumptions, and limitations. The research study evaluated crib dock construction methods throughout the Les Cheneaux and Drummond Island region of Lake Huron, to establish defined permit and construction norms that meet the structural needs of owners, while respecting the greater public's desire to maintain safe waterways and protect the Great Lakes bottomland and associated ecosystem. The research questions addressed were:

- What are the key crib dock siting considerations? How does dock siting and orientation affect weather loads and associated durability?
- What are the crib design and construction minimums for a given set of site considerations?

- How does the decking and superstructure affect appropriate siting and crib design decisions?
- What are the minimum and optimum ground anchorage standards for appropriate design and durability?

### *Review of Related Literature*

The second chapter provided a review of the literature related to the problem and literature related to the research design. The initial discussion addressed the historical, scholarly, and contextual background for the problem and its importance. It showed how public and commercial concern over building safety and unhealthy urban residential life led to numerous commissions and evaluations of building quality and standards. Based on those analyses, codes were implemented to obligate builders to provide safer, healthier commercial buildings and urban residential options. While the development of environmental laws was also in response to public concern over public health and well-being issues, the standards for correcting those issues were not as clearly established or justified. In addition, the responsibilities for environmental issues continue to be somewhat muddled. As a result, the crib dock permitting processes and the approval criteria associated with environmental laws are less well defined and at times their application appears uneven and capricious. The literature review did not show or infer any adverse ecological effects caused by crib docks but did show that they provide favorable sport fish habitat and, if built well, can provide safe boat moorage in a demanding climate for many years.

This discussion set the stage for the initial thoughts on research methodology options, which guided the review of the literature related to the research design. Given the nature of

the problem and the limited amount of related literature, the study used a mixed methods sequential exploratory strategy, using Grounded Theory in the initial qualitative phase and Direct Measurement in the subsequent quantitative phase.

### *Research Methodology & Design*

The third chapter outlined the variable definition, research design, and research procedures employed. As mentioned above, the study employed an exploratory mixed methods model, which is a two-phase sequential methodology with the initial phase being qualitative and the subsequent phase quantitative. The qualitative phase used the Grounded Theory approach with its trademark iterative data collection, interim analysis, and subsequent data collection. The primary data collection tool was semi-structured interviews with crib dock contractors, owners, government officials associated with approving the construction permits and standards, and dock construction material suppliers. The quantitative phase employed Direct Measurement of sample crib docks using an instrument developed based on the results of the qualitative phase. The instrument was primarily focused on deterministic attributes, but some qualitative attributes were included as well. The discussion of both phases included definition of the population and sample, instrumentation, and data collection, validation, and analysis.

### *Presentation & Analysis of Findings*

The fourth chapter presented the findings for the study's qualitative and quantitative phases and then integrated the two sets of findings. The primary data collection for the qualitative phase occurred over four weeks in the summer of 2006, and the primary



quantitative data collection was completed the following summer, with follow-up data collection for both phases done in May and July of 2008. The initial phase used the Grounded Theory research approach with purposive sampling. In all, 38 interviews were conducted: 16 with contractors, 11 with crib dock owners, and 11 with various government officials and building material suppliers. The quantitative phase employed Direct Measurement of a convenience sample of 20 serviceable crib docks, including 151 individual cribs. Analysis of these results addressed the problem's broader permit-processing issues and four primary issues: dock siting, crib design and construction, dock superstructure, and ground anchorage.

The Michigan Department of Environmental Quality (MDEQ) and the U.S. Army Corps of Engineers (USACE) are the reviewing and approving agencies for crib dock construction permit applications. The USACE has a role because the docks are built in the Great Lakes and the lakes are considered navigable waterways. By virtue of the 1899 Rivers and Harbors Act, the USACE is responsible for maintaining clear and unfettered navigable waterways. The MDEQ is involved because they are responsible for enforcing Michigan's Natural Resources Environmental Protection Act of 1994 (NREPA), and the docks are built on Great Lakes bottomland, which is protected state land by virtue of Part 325 of the NREPA. Representatives of both MDEQ and USACE were opposed to crib docks primarily because they are a navigable waterway obstruction and they occupy Great Lakes bottomland. When asked about research that establishes the ill effects of crib docks on the bottomlands, one of the MDEQ representatives stated, "You're probably not going to find anything." In contrast, the Michigan Department of Natural Resources (MDNR) and U.S. Forest Service (USFS) encourage submerged crib-based structures as an effective sport fish habitat

enhancement. The MDNR representative said they are always looking for viable options for increasing or enhancing water life habitat; cribs are one of the most effective options, and they generate far more habitat surface area than they consume. However, the ecological value of that surface area has not been formally validated. Crib docks cost from \$250 a running foot, because the construction work is done primarily by hand. However, if a dock is well sited, built, and maintained, it will provide well over 30 years of service in a very demanding climate. It is generally agreed that crib docks are the most viable option for many of the most exposed sites in the research area. However, the construction permit approval standards for crib docks are not well defined with regard to design and construction. One of the MDEQ representatives confirmed this and when asked about the norms or standards, their response was the approval standards are “rather informal and not really written down anywhere.” The MDEQ representatives, both in the UP and Lansing offices, expressed interest in some form of norms or guidelines for acceptable crib dock design standards. Other than the MDEQ-USACE permit approval, the only other review a proposed dock is subject to is the local township building inspector. According to a township official, crib docks are considered temporary structures and therefore not subject to the local or state residential building codes. However, it was noted that of the three townships in which crib docks were located in the study area, none were subjected to the local residential building codes. This is more likely a jurisdictional issue due to fact that the docks are not on the owners’ lots, but are on state land. State residential building codes, such as applied to decks, are not applicable. For example, these codes require that footing posts be buried at specified depths of approximately 42 inches. Crib docks utilize the substantial support provided by the dock itself and buried posts would not be appropriate. In fact, buried posts would

weaken the structure due to ice jacking. The only township concern in considering a proposed crib dock is whether it meets the shoreline zoning requirements.

The two key design factors in siting crib docks were protecting against winter ice loading exposure and accommodating littoral drift. Failure to accommodate site exposure will result in severe ice damage. To accommodate the winter weathering on sites with moderate to severe site exposure, the dock ends may be angled to face the greatest fetch; have larger, reinforced cribs to anchor exposed ends; or increase the number and frequency of ground anchor piling. The second factor, littoral drift, may erode and undercut the cribs, causing them to tilt and eventually topple over. One other potential cause of tipping is unlevel crib bases at installation. For the most part, littoral flow was addressed by 1) flow spacing at the ordinary high water mark (OHWM) and 2) overall flow spacing for the entire dock structure. The gap left at the OHWM ranged from zero to 18 feet. The mean was 6.75 feet, but the mode was 11 feet, in keeping with the current, unofficial standard of the MDEQ. As for overall flow spacing for the entire dock, the MDEQ seeks to maintain 50 percent of the running dock length to be open to littoral flow but will accept 40 percent, which is the accepted norm. The docks that met these flow spacing norms showed far less ill effect from littoral flow.

As for crib design and construction, the material used was found to be a matter of choice and cost. In the research area, cedar was predominantly used primarily due to availability. Environmentally approved, pressure treated, milled timbers would probably be stronger and last longer but cost approximately 1.5 times as much. However, it was found that if treated 2-inch joists were used, the gaps between cribs could be increased to over 15 feet and 50% flow spacing easily achieved. The greater spacing may reduce the number

of cribs required, the associated costs, and the dock's environmental impact. However, the use of 2 inch joist systems would increase construction costs. Maintenance costs when repairing minor settling will also increase.

The primary fastener used throughout the research area was the 12" galvanized timber spike. According to the literature, a crib's height should not exceed either the base width or length dimensions; exceeding this dimensional standard would undermine the crib's stability during winter ice loading. Of the 124 cribs evaluated for height versus base dimensions, over 90% were found to be no taller than either of their base dimensions, width or length. Of the 12 that violated this norm, four were interior intermediate cribs in a complex fork configured dock, consisting of 15 cribs. Once the cribs are constructed and on site, they are floated into place and loaded with ballast until they reach neutral buoyancy. They are then precisely sited and fully loaded with ballast. The ballast rock is brought in from off site and was typically unwashed 6" to 12" crushed quarry limestone; an eight foot square crib takes 10 to 12 ton of stone.

In the dock superstructure and ground anchorage findings, over 90% of the dock sample had 8 foot wide decks, and all but one of the docks in the sample set used driven pilings for ground anchorage. Typically, the decking consisted of 2" x 6" planking supported by three 6" x 6" timber stringers, installed on approximate four foot centers. The deck materials rarely appeared to be pressure treated, but it was difficult to tell once the lumber had weathered a few seasons. One builder often applied a common wood deck preservative after construction was complete. Materials research showed that treated decking cost 60% more than untreated pine, but would last well over twice as long. It was not known if anyone used untreated pine decking crib dock; 90% of new construction uses treated pine and 10%

owner specified cedar, which is 80% more costly. A 2x6-8' treated pine cost \$4.80/plank or .60 board foot. Cedar 2x6-8' cost \$8.00/plank or higher or \$1.00 bf making it a cost-effective alternative. Untreated cedar lasts as long as treated pine and costs less in the research area due to the abundance of locally milled cedar. In place of pilings, some docks used oversized cribs for primary ground anchorage. On all but three of the docks with pilings, the pilings were driven taper down. There was no apparent advantage of one method over the other; pilings driven taper first did look more attractive than those driven butt first. The spacing ranged from 4- to 8-foot centers with an average spacing of 5.4 feet. The greater number of pilings, the stronger the dock. The variation in piling spacing was primarily a site design and cost decision in response to anticipated winter ice loading.

The study data validation considered both phases and the integrated findings using detailed sample analysis; iterative and redundant data collection; extensive written and photographic records; findings triangulation between the qualitative and quantitative phases; peer reviews by the dissertation chair, committee members, and selected respondents; and the investigator's experience, which grew as the study progressed. The anticipated issues were sample size due the constrained research area and sample diversity between mainland and island sited docks. After data validation, neither of these issues were a concern. However, two issues were identified: qualitative sample diversity and dock sample site exposure. In the qualitative phase, sample diversity was found to be a problem: for the contractors, half of the interviews were with one respondent; and for the dock owners, a third of the interviews were with one respondent. This in-effect sample weighting was closely monitored in the quantitative phase sample selection and data collection to guard against skewing of the findings. The quantitative phase's fetch analysis showed how fall and winter prevailing

winds affect the research area. It also showed that none of the quantitative sample docks were sited in the most severely exposed areas, which is a prevailing southwesterly wind in the winter months. Many docks have SW exposure, but few with direct Lake Huron fetch. It is understood that prevailing winds are not the only direction of the wind on all days. Docks with the greatest amount of fetch were angled into the fetch direction. This is an issue that will need to be addressed in subsequent exploration of this problem.

### Conclusions

In light of this study's exploratory intent, design, and limitations, the conclusions are somewhat inductive in nature; they better define the primary issues addressed and raise questions about the broader issues. Crib docks are an essentially unexplored topic, and many of the conclusions present issues for subsequent research. The conclusions are presented in two clusters. Initially, they address the incomplete, confusing, and contradictory nature of governmental oversight of crib dock construction approval and inspection in the research area. The discussion then addresses recommended crib dock approval and construction standards, standards that address both environmental and structural concerns.

#### *Governmental Oversight of Crib Dock Construction*

As shown in Figure 18, there are seven interested parties when considering crib dock related issues: two are essentially the *REQUESTERS*, the owners and their contractors; two are *APPROVERS*, the USACE and MDEQ; one limited approver, the local government; and two interested spectators, the MDNR and the USFS. The eventual dock owners and their design-build contractors are primarily concerned with a proposed dock's functionality,

durability, aesthetics, safety, and cost. To a degree, both are interested in being good community citizens with regard to the environment and aesthetics; however, from time to time both contractors and owners appeared willing to “cut corners” to achieve their desired ends. The USACE and the MDEQ are the approving authorities for crib docks, but for

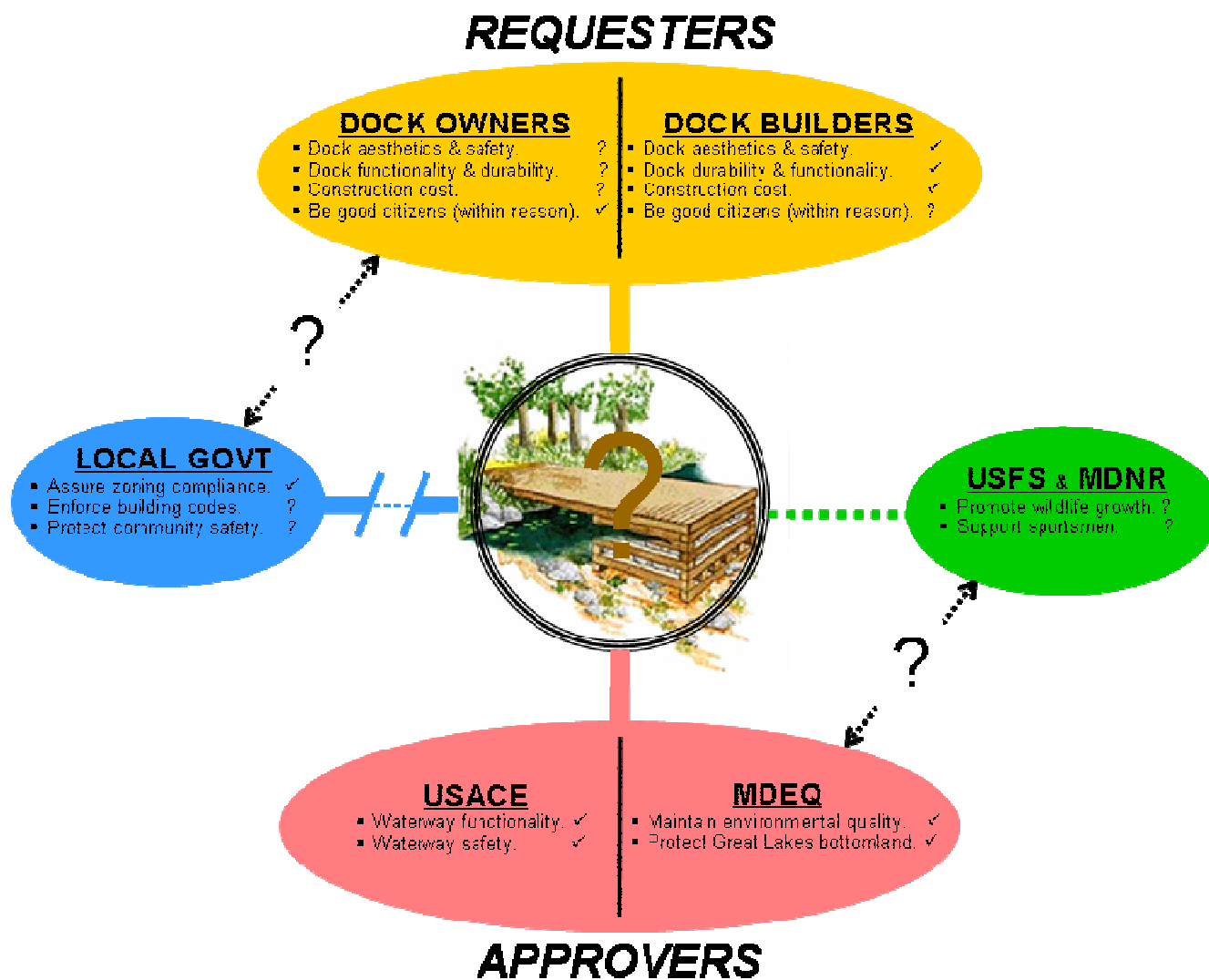

Figure 18. Government Oversight of Crib Dock Construction.

differing reasons. The Corps is primarily concerned with maintaining the Great Lakes as safe and functional waterways, that is, ensuring a proposed dock does not create a safety

hazard or unduly impede water traffic. The MDEQ, on the other hand, is responsible for protecting and maintaining the Great Lakes bottomlands. The local government, Clark Township for much of the research area, considers the docks to be temporary structures and therefore not subject to the building code. In addition, the township may not believe it has jurisdiction because the docks are on state land. As a result, the local government's only active role in considering a proposed crib dock construction project is whether or not it meets shoreline zoning restrictions. The two simply interested parties in the issue are the MDNR and USFS are responsible for sustaining and enhancing wildlife. The MDNR, in concert with the USFS, encourages crib-based structures to promote sport fish population growth. As a result, two key issues come to light: 1) multiple government entities are working at cross purposes, leaving the citizen-owner in a confusing position; and 2) while the MDEQ and Corps inspect the docks for public benefit and safety issues, there are no design, construction, or maintenance standards to base inspections upon.

### *Conflicting Government Roles & Priorities*

As outlined above and shown in Figure 18, the governmental oversight and approval of crib dock construction puts two federal government agencies, the USACE and the USFS, as well as two state government agencies, the MDEQ and MDNR, working at cross purposes. In accordance with Section 10 of the Rivers and Harbors Act of 1899, the Corps is responsible for ensuring clear, unobstructed interstate waterways, which include the Great Lakes, while the MDEQ is charged by the state's NREPA Part 305 "*with regulating construction activities along [the] 3,165 miles of Great Lakes shoreline and over 38,000 square miles of bottomlands.*" Crib docks, by virtue of their design, are in conflict with both



of the MDEQ and USACE missions, so both governmental agencies strongly discourage their construction. However, the MDNR is responsible for “*the conservation, protection, management, use, and enjoyment of the State’s natural resources for current and future generations.*” This role includes wildlife habitat enhancement and support of sport fishing. Similarly, the USFS is charged with maintaining and enhancing wildlife habitat throughout the national forest system, which encompasses much of the Upper Peninsula. Both the USFS and the MDNR strongly believe there is sufficient experiential evidence that submerged crib-based structures promote sport fish population growth. Hence, they support the construction of crib docks. To the citizen-dock owner, these opposing positions present a confusing, frustrating situation. The MDEQ and USACE are discouraging the building of crib docks, while the MDNR and USFS are publicizing the habitat enhancement generated by crib-based structures. While both positions are justified and warranted, the conflicting positions appear to the citizen as a case of government bureaucracy working at cross purposes with no effort being made to resolve the conflicts.

#### *Existing Building Codes Related to Crib Docks*

Since 2000, all one- and two-family residential structures built within the State of Michigan are to be constructed in compliance with the state’s residential building code. According to the Michigan Residential Code, its purpose is to:

Provide minimum requirements to safeguard the public safety, health and general welfare, through affordability, structural strength, means of egress facilities, stability, sanitation, light and ventilation, energy conservation and safety to life and property from fire and other hazards attributed to the built environment. (MDLEG, 2003, p. 1)

The code also applies to accessory structures, which it defines as "... a building [or structure], the use of which is incidental to that of the main building and which is located on the same lot" (MDLEG, 2003, p. 9). Examples of accessory structures include a barn, separate garage, tool shed, or boat dock. While portions of the Michigan Residential Code may be applicable to crib docks, much of the code is not. Footing requirements are one example mentioned earlier. It must also be understood that docks serve a different purpose than a deck. In addition to providing a platform to access ones boat, they provide protection from wave action. The Les Cheneaux Island area is well known for its collection of antique wooden boats. Excessive spans between cribs, which are allowed on decks, permits wave action to cause excessive damage to these beautiful, delicate, and expensive craft.

Alternatives, such as sheet piling piers are economically prohibitive, far less aesthetically pleasing and environmentally unsound. So, while the Michigan Residential Building Code is a useful reference for developing some aspects of a design and construction it should not be adopted in whole. (General Note: MDNR Fisheries personnel prefer crib docks for the habitat they create; their second choice is floating docks, while steel sheet piling docks are the least favored option.) In addition to the state residential code, the USACE has established specific building code requirements for dock structures used on Corps recreational bodies of water (Corps of Engineers Engineering Regulation (ER) 1130-2-406, Shoreline Management at Civil Works Projects). However, in the qualitative phase of this study, it was discovered that no building code requirements were being considered in the review and approval of crib dock construction permit applications. The Corps said they defer to the state on code issues, while the MDEQ said that they accept the expertise of the contractors who design and build the docks. The literature review also outlined that, in

Michigan, the local government is responsible for enforcement of the state building code's structural standards. It seems acceptable that a state agency, such as the MDEQ, could assume this responsibility, much the same as state inspectors are responsible for enforcement of fire suppression building codes. This ensures consistency in interpretation so that local building inspectors are not attempting to enforce such items as the minimum footing depth described above. It is also more effective utilization of resources, as MDEQ representative already inspect the docks. Finally, it must be recognized that the underlying problem of this study is that more than one government agency is involved in the permitting process. Adding an additional layer of government permitting and control seems counter to this end. Prospective dock owners need to be protected from unscrupulous dock design-build contractors. Likewise, they need to be protected from the well intentioned, but inexperienced, contractor that can build a fine house or deck but has no concept of the conditions that a crib dock is subjected to. There is also a need to protect unwary visitors from unserviceable, unsafe dock structures. So, clearly some form of design, construction, and maintenance standards for these docks is needed for those issues specific to permanent docks.

Clearly, some form of design, construction, and maintenance standards for these docks is needed, either in accordance with some aspects of the Michigan Residential Code for those aspects of dock construction covered the code addresses or by the Corps of Engineers Engineering Regulation (ER) 1130-2-406, for those issues specific to permanent docks. It would be preferred that some combination of these codes and regulations be adopted that would best serve the needs of the owners, public, and contractors involved in the design and construction of crib docks.

*Crib Dock Approval & Construction Standards*

Table 8 below outlines the key issues to be discussed in the conclusions regarding recommended crib dock approval and construction standards. The discussion of recommended approval standards covers the environmental conclusions of this study and how they should be considered in the evaluation of an owner's application for approval to build a crib dock. The discussion of construction standards addresses structural design considerations that could be enforced by the MDEQ inspectors during the construction and subsequent maintenance of crib docks in protection of dock owners and the public welfare against poorly designed, constructed, or maintained crib docks.

Table 8

*Recommended Crib Dock Approval & Construction Standards*

<b><i>Approval Standards:</i></b>	<b><i>Construction Standards:</i></b>
<ul style="list-style-type: none"> <li>• Crib spans &amp; spacing.</li> <li>• OHWM &amp; overall flow spacing.</li> <li>• Washed ballast.</li> <li>• Waterway safety markings.</li> </ul>	<ul style="list-style-type: none"> <li>• Decking &amp; electrical standards.</li> <li>• USACE dock safety requirements.</li> <li>• Crib dimensional standards.</li> <li>• Apply selected portions of the Michigan residential code.</li> </ul>

*Crib Dock Approval Standards*

This discussion will address crib dock design standards that will mitigate their adverse environmental effects, those effects that impede littoral flow, consume Great Lakes bottomland, reduce wildlife habitat, and create unsafe waterways. These standards, if

adopted, would significantly reduce a crib dock's negative ecological "footprint" while still achieving the same serviceability and cost desired by requesting dock owners.

Of the negative impacts, the two primary objections to crib docks, raised by the MDEQ, were their occupation of Great Lakes bottomland and their interference with littoral flow. These issues are, to a great extent, driven by three variables: 1) how many cribs a dock requires; 2) how close together the cribs need to be; and 3) how large they need to be. How big the cribs need to be is directly related to how exposed a given dock site is and the degree of winter ice loading the site is likely to incur, which cannot be mitigated by design standards. However, the number and spacing of the cribs is directly related to how far apart the cribs can be placed in a dock application. The further apart the cribs are placed, the less bottomland they occupy and the less they interfere with littoral flow. In both the qualitative and quantitative findings, it was found that crib spacing was limited by the allowable deck stringer span. The commonly used deck stringer was 6" x 6" timbers, which allowed up to 11' between dock cribs, which is the accepted norm. This is another example of how crib dock requirements are different than those of patio decks. The use of 6" x 6" timbers as deck stringers or joists is contrary to the Michigan Residential Code. The code calls for the use of 2-inch lumber joists. In the qualitative findings, dock builders contend that 2-inch lumber will not stand up to the moisture-laden environment of a freshwater dock deck application. In the quantitative findings, docks with 2-inch deck joists were found that had been in use for over 20 years. While the owners could not always confirm, these 2-inch lumber joists were probably pressure treated. Research by the USFS Forest Products Laboratory shows that treated pine lumber will last more than 10 times longer than untreated lumber. A big problem with joist is leveling from settling of cribs, especially if a boathouse covers it. It is

common practice of cutting grooves into the top crib log for joists. It may be possible to use 2 inch treated lumber for the dock deck joists on the surface of the crib. However, the application of 2 inch treated lumber between cribs to increase span is questionable due to the fact that the environment is different between residential decks and docks. In addition to the moisture factor, docks are subjected to additional stresses caused by ice. It was noted during the qualitative phase of the study that the state of Florida prescribes a maximum joist span of 10 feet. The reason for this restriction is sagging in span areas, but there may very well be factors, such as safety or durability, that offset the occupation of bottomland and interference with littoral flow. It may be possible to increase this span, either with additional 6" x 6" stringers or with appropriately sized and spaced 2 inch lumber joists. However, this would increase the cost of the dock, unless it is possible to offset the cost through a reduced number of cribs. The choice would be dependent on the length of the dock. For example, there would be no advantage in a longer span for a 50 foot dock, assuming 16 foot long cribs. With 16 foot long cribs, it would not be possible to reduce the number of cribs from six with an 11 foot span to five with a 16 foot span until the dock with 11 foot spans is 162 feet long and the dock with 16 foot spans was 160 foot long. Crib spacing should be done in consultation between the builder and the owner. For example, if an owner desired a 100 foot dock, they may prefer a 96 foot dock with 16 foot spacing, as opposed to a 108 foot dock with 11 foot spacing. However, if water depth determined that at least 100 foot was needed for boat dockage, the dock with the 11 foot span would be desirable; again, assuming that 16 foot long cribs were used. As will be stated earlier, the Corps defers to the state on structural issues, while the MDEQ indicated that they accept the expertise of the contractors who design and build the docks. As can be seen in the examples provided above, this is a

prudent practice when dealing with reputable and experienced contractors. Such contractors understand the cost and practicality of appropriately designed and sited crib docks. As is noted earlier, a disproportionate number of the interviews were with one contractor. Upon spending a considerable amount of time in the field, it became apparent that this particular contractor had established the “best practices” in terms of crib dock design and construction. It is recommended that such contractors be identified and consulted by the MDEQ in establishing crib dock design and construction standards.

The crib spacing of at least 11 feet will allow for greater littoral flow spacing within the overall dock design and site layout. Littoral flow is the natural movement of water parallel to the shoreline resulting from wind-driven waves striking the shoreline at an angle. The flow is a critical element of littoral ecosystems, and the flow next to the OHWM is the most critical. Interference with the littoral flow was the most readily apparent adverse environmental impact of crib docks observed during the data collection. Sediment carried by the littoral flow was deposited against the upstream side of the cribs and in the lee area downstream of the cribs. This sedimentation reduces adjacent water depth, limiting the dock’s usability. This was often addressed by owners using their boat motor’s propeller wash to blow the sediment back out into the flow stream, amplifying the negative effect of the dock’s location and design. In addition, the littoral flow may scour the crib substrate over time, causing the cribs to tilt and, if not corrected, ultimately fall over; acknowledging that other factors such as slanted lake bottom may also cause tipping. The MDEQ currently accepts 11-foot crib spacing in proposed docks, which provides approximately 40% clear flow area. Using the deck spans discussed above, the MDEQ could require that proposed docks be designed and built so as to achieve at least 40% clear flow space to accommodate

the natural littoral flow. Clear flow spacing should be defined as completely unobstructed flow area; therefore, the same crib spacing will be used in parallel portions of a proposed dock to allow for unobstructed flow in both legs of the dock. The spacing at the 10 year OHWM may be increased with a specified percentage of the gap being above the current high water mark to accommodate high water mark fluctuation. Again, the MDEQ should consult with reputable crib dock contractors to determine what this standard should be, considering the forces applied at these areas and the costs involved in increasing the gap at the OHWM. Increasing the crib spacing would reduce a proposed dock's interference with the natural littoral flow; builders often increase spans at the OHWM as a cost saving measure.

Beyond littoral flow, the second key crib dock concern is the occupation of Great Lakes bottomland, because there is only a fixed amount of bottomland. However, it is also because occupation of bottomland interferes with the littoral zone ecosystem. Crib docks actually increase the benthic surface area necessary for many life forms in the littoral zone. To insure that the maximum surface area is created fines should be minimized and the use of small ballast controlled to provide interstitial space between the rocks. The small interstitial spaces provide relatively calm water and surface area for the growth of benthic plant life, which provide food for young fish fry. Similarly, the protected small spaces provide sanctuary for developing fish to grow and develop in a habitat free from larger predators. Likewise, they provide space for bait fish and crayfish to thrive supporting the food chain for larger game fish. The loss of this interstitial space due to it being filled with fines reduces the crib's ability to provide viable sport fishing habitat. While anecdotal, it is suspected that the excellent reputation for sport fishing in the Les Cheneaux Islands area is due to a great



extent to the presence of crib docks over an extended period of time. The docks in the area were loaded with crushed quarry limestone and field stone. It is recommended that such ballast be washed or screened to reduce fines. The ballast should be screened to ensure that it is six inches or more in diameter. Recycled aggregate, such as concrete from roads and parking lots, should not be utilized to ensure that the ballast is contaminant free.

The last dock siting concern arises from the Corps' responsibility for maintaining safe, unobstructed waterways. In concert with this, the Corps prefers seasonal docks be used instead of permanent docks, like crib docks. However, it continues to approve crib docks for construction in concert with the joint USACE-MDEQ approval process. Given that these are permanent docks, the Corps has been exercising reasonable prudence by minimizing the hazard permanent docks present to other boaters during the moderate seasons and other waterway users during the winter season, such as snowmobilers. The primary way of minimizing the hazards is to keep the docks out of navigable channels. To further improve safety all permanent docks, to include crib docks, should be required to have clearly visible reflective devices that will mark how far the dock extends into the waterway. For particularly dangerous sites, the docks should be required to be lighted during all periods of reduced visibility. Compliance with these requirements should be demonstrated by plan review before a dock is approved and construction allowed to proceed. Requiring these simple safety measures would dramatically reduce the obstacle danger permanent docks present.

### *Crib Dock Construction Standards*

The previous discussion presented crib dock design standards that, if implemented, will mitigate the adverse environmental effects of crib docks. This discussion will address crib dock standards that could be enforced by MDEQ inspectors during the construction and subsequent maintenance of crib docks in protection of dock owners and the general public from poorly constructed or maintained crib docks. It covers issues identified during the findings analysis that could be addressed by developing standards that, for the most part, are already approved and accepted as prudent and reasonable in either applicable portions of the Michigan Building Code or the USACE codes for dock structures used in Corps recreational bodies of water. Reputable contractors should participate in the development of these standards to ensure that they take the unique structural aspects of crib docks into account and can be implemented at a reasonable cost.

Two key examples of potential applicability of the Michigan Residential Code for permanent docks noted during the study concern dock decking and electrical service. The majority of the deck planking is treated 2" x 6". The remainder was cedar which is an acceptable replacement in accordance with the Michigan Residential Code. As stated earlier this is difficult to determine once the decking has weathered more than a couple years, so this should be checked during construction. The decking on 80% of the dock sample consisted of 2" x 6" planking set on three joists/stringers at 46" centers. This common dock deck design allowed a significant amount of flex when walking on the deck surface. One of the contractors indicated that if flex is present then joists are added. The Michigan Residential Code requires that two-inch deck material be placed on joists set at 24" centers and 5/4" decking on joists at 16" centers. This joist spacing would provide a much more stable, safe

deck surface. As for electrical, five of the sample docks had permanently installed electric service and some were not Ground Fault Interrupt (GFI) protected. The state residential code requires GFI protected circuits for all outdoor receptacles (MDLEG, 2003, p. 457). These are two examples where key elements of the Michigan Residential Code, applicable to accessory buildings, should be included in the standard and applied to crib docks.

In the course of evaluating the sample docks, approximately 30% were found to have safety issues that should be addressed and probably should have been addressed when they were built. These are structural issues peculiar to permanent dock structures that should be covered by local building ordinances. In particular the MDEQ should consider adopting aspects of the Corps of Engineers Engineering Regulation (ER) 1130-2-406, Shoreline Management at Civil Works Projects, which establishes standards for docks and other shoreline structures. For instance, with regard to deck material, the regulation calls for all dock ramps, walkways, and decking to be constructed of treated lumber. It is assumed that cedar would be equally acceptable. The Corps shoreline regulation further states that a deck surface:

...is considered unsafe when nails, bolts, or screws are protruding to cause a trip hazard; when materials become partially decayed or slick from use; when materials become ripped, jagged, pointed, splintered from wind or other factors; when wood supports and decking become loose or missing, when wooden materials protrude beyond the defined limits of the structure's approved dimensions. (Mobile District, 2004, p. 14)

Situations in violation of this standard were found on four of the sample docks, two of which were being used commercially, creating a very unsafe public use environment. The Corps regulation also requires handrails on steps and approach walkways more than 48" above the ground or water. Handrails were rarely used on the sample docks. Adoption of these

standards by local governments with jurisdiction over shoreline areas would make their permanent docks much safer.

In addition to the safety issues addressed above, there is one structural integrity issue that should be addressed in local permanent dock ordinances that applies strictly to crib docks: crib dimensional standards. The literature search found references that stated cribs should be no higher than their base length or width, whichever was less. For example, if the crib is 8 feet by 12 feet, it should be no taller than 8 feet, regardless of the crib's orientation within the structure. This dimensional standard was not specifically validated in this research, but it was an item of interest and checked on the majority of the cribs in the dock sample. Of the 124 cribs evaluated for height versus base dimensions, only 12 were found to be taller than either of their base dimensions. This clearly shows that the preponderance of dock builders subscribe to this standard and find it to be appropriate. However, of the 12 that were found to violate the standard, two were used in a dock that was less than two years old, were in a relatively exposed setting, and were clearly at risk if exposed to serious ice loading. Other aspects of this particular dock's construction indicated the contractor often "cut corners." To protect against this, the dimensions of the cribs to be built within a proposed dock structure should be required to meet the proposed standard. If this standard was included in the new code and new cribs were inspected by the DEQ inspector, owners would be protected against unscrupulous or inattentive construction techniques.

### Limitations

The applicability of the findings and conclusions of this study are limited with regard to the geographic and demographic constraints of the research area, the construct constraints

of the study methodology employed, the projectability constraints imposed by the size and design of the dock sample used, and, to a degree, by climate change.

### *Research Area*

The study's research area was specifically limited to the Upper Peninsula Lake Huron shoreline, which is only about 50 miles in length. This relatively confined area is very rural with limited population. The research area was selected for its abundance of crib docks, the primary focus of the study, which was key to the quantitative phase of the project. However, the constraints of the research area limited elements of the qualitative phase. In particular, the nature of the community and the very limited number of contractors meant their techniques were not entirely independent of each other. It also precluded exploring whether approaches to key issues were merely local artifacts or also found in other geographic regions where crib docks are common. These other areas include the Keweenaw Peninsula of Michigan, central Ontario, the border lakes region of Ontario and Minnesota, the upstate and Finger Lakes region of New York, and the northern Great Plains.

### *Study Methodology*

The study employed a two-phase mixed methods exploratory research methodology, which called for a qualitative phase followed by a quantitative phase. The qualitative phase used the Grounded Theory approach with its trademark iterative data collection, interim analysis, and subsequent data collection using semi-structured interviews with crib dock contractors, owners, government officials, and construction material suppliers. The quantitative phase employed Direct Measurement of a 20-dock sample of in-service crib

docks, using an instrument primarily focused on the docks' deterministic attributes and qualitative attributes. These two methodologies, while appropriate for exploration of this problem, were extremely time intensive and limited the number of respondents who could be interviewed and developed and the number of in-service crib docks that could be assessed. These constraints severely limit how projectable the findings are to the broader population of crib docks, owners, and contractors; hence the findings and conclusions were somewhat inductive in nature. They need further exploration before making any definitive population projections.

#### *Dock Sample*

During the analysis of the quantitative sample, it was discovered that none of the sample crib docks were located in the most severely exposed areas of the research area. The quantitative sample analysis included a GIS computer-driven fetch exposure analytic model. Fetch is the clear, unimpeded distance a given wind will blow before reaching a shoreline location. It is a proxy measure of the expected winter ice loading a specific sample dock needs to endure. This GIS fetch analysis showed how the bulk of the research area is protected from the greatest winter weather exposure. It also showed that that none of the sample docks were located in the most severely exposed zones of the research area. This is a significant oversight that limits the findings with regard to ground anchorage for the most exposed sites.

### *Climate Change*

The key advantage of crib docks is their unitary structure, which allows them to accommodate ice jacking. The unitary structure allows the crib piers to rise with the winter seiche cycles and reset when the ice relaxes. However, of the three dock options in the research area, crib docks are the most expensive, because they involve extensive manual labor to construct. Should climate change cause the winters in the research area to moderate sufficiently that ice loading and jacking is no longer the primary threat to boat docks, then the other dock options would probably become preferable. Piling and floating docks are cheaper and, as of now, easier to get approved by the MDEQ and USACE. As a result, the significance of the study's findings is limited by the possibility that climate change will, over time, cause crib docks to become obsolete and the study's findings moot.

### Recommendations

As mentioned earlier, the conclusions of this study are a mix of procedural and structural insights, with regard to the construction of crib docks within the defined research area. The procedural insights present issues with the way crib docks, and other permanent docks, are handled by various government agencies: federal, state, and local. The structural conclusions provide many useful insights that should be considered by those same governmental agencies. In addition to these procedural issues, the study was constrained by design limitations and key issues that had not been addressed by scholarly inquiry.

Therefore, the recommendations of this study are organized in two groups: 1) recommendations for government action; and 2) recommendations for further research.

*Recommendations for Government Action*

These recommendations include actions that could be taken on the part of specified federal and state agencies to address crib dock design and construction issues identified in the course of this research study.

*MDEQ and USACE develop crib dock design and construction standards*

The MDEQ and USACE jointly are the approval authority for applications to site and build crib docks within Michigan. Two different MDEQ representatives stated that 1) there are no defined standards for the approval of crib dock design and construction; 2) MDEQ depends on the design-build contractors' judgment in considering the structural aspects of a crib dock construction application; and 3) they would be very interested in developing a set of approval standards for crib dock construction permit applications. The lack of standards has led to frustration on the part of citizen-owner applicants who consider the approval process ill-defined in terms of design and construction. In light of this, the MDEQ Land and Water Permits Division should evaluate the conclusions of this study and use them as the basis for a defined set of crib dock design and construction approval standards. These actions would significantly clarify the crib dock approval process and reduce frustration by owners and design-build contractors. In addition, the MDEQ should require that crib dock applications be reviewed in accordance with the design and construction standards that are developed. These standards should be developed in conjunction with the USACE and should include input from their respective sister agencies, the MDNR and the USFS, as described below. Likewise, reputable crib dock contractors should be consulted to ensure that



the designs are both structurally and cost effective. A recommended set of crib dock design and construction standards based on this study is provided at Appendix 9.

*MDEQ and MDNR resolve conflicting positions on crib docks*

The MDEQ is the primary state approval authority for crib dock construction permit applications. They are generally opposed to crib docks because they occupy Great Lakes bottomland and interfere with shoreline littoral flow. In contrast, the MDNR encourages submerged crib-based structures as an effective sport fish habitat enhancement. The MDNR representatives said they are always looking for viable options for increasing or enhancing water life habitat; cribs are one of the most effective options, and they generate far more habitat surface area than they consume. These opposing positions are justified when considered in isolation, but in context they confuse and frustrate crib dock applicants and contractors. How can a crib dock be considered environmentally detrimental to one government agency while environmentally advantageous to another agency? The MDEQ and the MDNR, as well as the USACE and the USFS, should consider the conclusions and insights developed in this study and develop a joint environmental impact assessment for considering crib docks and other submerged crib-based structures. This assessment should clearly delineate the environmental implications, both positive and negative, of crib dock construction to give some structure to evaluation of the situational specifics of a particular crib dock application and whether approval is appropriate. These findings should be included in the MDEQ-USACE crib dock approval standards.

*State government apply a design and construction standard to permanent docks*

During the qualitative phase, it was discovered that the local government, Clark Township has determined that crib docks are not subject to the state building code. The findings also showed that crib docks typically last 30 or more years. Observed unsafe situations in the sample included: excessive structural flex in decking, absence of handrails on some stairs and raised walkways, and outdoor electrical outlets without GFI protection. To protect against these and other unsafe structures, all permanent docks, to include crib docks, should be held to a design and construction code. The appropriate enforcement by the MDEQ would need to include construction plan review and approval, in-progress construction inspection and approval, and final code compliance inspection and approval upon completion with required corrective actions completed prior to authorizing project close. In this way, the MDEQ can ensure that permanent docks are fully in compliance with the new design and construction code.

*State Model Township Building Ordinance to Cover Permanent Docks.*

In addition to the design and construction code, local governments with a significant amount of shoreline, inland or Great Lakes, need a model ordinance that deals with structural and zoning issues peculiar to permanent dock structures, like crib docks, but not currently addressed by the state residential code. Clark Township, one of the local governments in the research area, has a boathouse ordinance that does address zoning issues. The Michigan Department of Labor and Economic Growth (MDLEG), which oversees state construction codes, should develop a model ordinance that establishes standards for permanent docks and other shoreline structures. This model ordinance should be based on key aspects of the

USACE Engineering Regulation (ER) 1130-2-406, Shoreline Management at Civil Works Projects and the Michigan Building Code. The permanent dock issues included should address material standards, walkway and moorage area minimum dimensions, railings and stairways, surface safety, boathouses, and periodic inspections. For instance, the Corps regulation calls for all dock ramps, walkways, and decking to be constructed of treated lumber. In addition to treated lumber, cedar decking should also be acceptable, but deck materials that are slippery when wet should be discouraged. The Corps regulation further defines specific minimums for walkways and hand railings and defines acceptable safety norms for walkway and moorage surfaces; unsafe deck surfaces were observed on at least four of the sample crib docks. The model ordinance should further direct that structures placed upon permanent decks be subject to design review and constructed in accordance with all applicable building codes and that all permanent docks and associated structures be inspected periodically to ensure continued compliance and safety. By developing a model ordinance applicable to permanent dock structures, the MDEQ will significantly improve public and commercial safety along their shorelines.

#### *Recommendations for Further Study*

These recommendations address issues that were identified in the course the study that require additional research to explore questions raised, validate findings made, or expand upon the conclusions drawn from those findings.

### *Applicability of Findings beyond the Research Area*

The key limitation throughout this study was the defined by the limited research area. The research area was constrained to allow for a more manageable study and meaningful set of findings. However, it limited the degree to which the findings could be applied to other geographic areas of Michigan, the Great Lakes, the northern tier of states, and Canada. Future inquiry should be directed towards determining if the results of this work hold true for other northern areas where crib docks are commonly built and used. In that building codes are a state regulation, this follow-on work should pursue a similar research design in other areas of Michigan's upper Great Lakes: the northern portion of the lower peninsula; the northern shore of Lake Michigan, the Lake Superior shore, and the Keweenaw Peninsula. The next step would be to explore the applicability to other areas where crib docks are common, western and northern Lake Superior, the boundary waters of Minnesota, the Finger Lakes of New York, and the Georgian Bay region of Ontario.

### *Ground Anchorage versus Dock Site Exposure Risk Assessment*

Throughout the study, one of the key factors in crib dock durability was dock's ability to withstand the winter weathering and ice loading. While the factor was not directly studied, winter fetch was used as analytic proxy for scaling a site's level of exposure to ice damage. This analysis was flawed to a degree by two factors, the crib dock sample and the failure to address all factors involved. During the quantitative findings analysis, it was determined that the crib dock sample did not include docks located in the portion of the research area exposed to the greatest winter fetch exposure, southwesterly winds during October through December or northwesterly winds in January through March. Hence, none

of the sample docks could be evaluated for durability in the face of the greatest ice damage risk. Also during the quantitative phase findings analysis, it was discovered that, in addition to fetch, a site's bathymetry appeared to play a key role in the site's degree of ice damage risk exposure. That is, if a reef or other form of shoal protected a particular site, it would mitigate the degree of risk that fetch alone imposed. Further research into the affect of these two variables on crib dock ice damage risk exposure should be done to better determine how ground anchorage design variables should be adjusted given a site's fetch and bathymetry. A possible approach would be data mining of the crib dimensional data and ground anchorage data to identify key variables that are associated with specific site exposure and dock design variables. Ideally, this research would result in some form of nomograph or computer model that would allow the dock designer to enter a proposed dock site's fetch, shoreline orientation, and littoral bathymetry and provide crib sizing and piling requirements as an output.

#### *Freshwater Littoral Ecosystem Impact of Crib Docks*

One of the primary factors contributing to the confusion over crib dock construction permitting is the question concerning their adverse ecological impact. When asked about research that validates the claim, MDEQ representatives stated that there was no rigorous research into the ecosystem impacts of crib docks. Similarly, the MDNR representatives encouraged the use of submerged crib-based structures as a means of enhancing freshwater habitat and strongly believe there is sufficient experiential evidence that shows submerged crib-based structures promote sport fish population growth, even though there was no academic research to validate their position. They stated that cribs generate far more benthic

surface area than they consume; however, again there was no scholarly work to validate this statement. However, the MDNR representatives felt there was sufficient experiential data to justify their position. These conflicting positions and the overall ecological impact of crib-based structures should be fully researched to determine their effect on littoral flow, lake bottom substrate, freshwater wildlife habitat, and fish population.

### Closing

This study explored the permitting, design, and construction of crib docks in the Les Cheneaux and Drummond Island region of Michigan's northern Lake Huron shoreline. It employed a mixed methods research design to first qualitatively explore and define the problem using a Grounded Theory approach followed by a quantitative descriptive analysis of in-use crib docks. The initial phase consisted of semi-structured interviews with experienced crib dock contractors and found that dock design and construction permit approval standards were ill-defined, leading to structures designed to meet what would be approved rather than defined structural serviceability and public safety requirements. The study subsequently used Direct Measurement of a defined convenience sample of in-use crib docks to determine appropriate construction norms that would meet functional requirements of owners while respecting the greater public's desire to maintain safe waterways and protect the Great Lakes bottomland and associated water life and vegetation. The crib dock variables considered included dock siting, crib design and construction minimums, decking and superstructure, and ground anchorage.

The findings addressed the broader social and governmental findings and implications and then the narrower issues applicable to crib dock permit and construction norms or

standards. The broader process findings demonstrated that there are seven interested parties when considering crib dock related issues: the owners and their contractors; the USACE and MDEQ; the local government; and the MDNR and the USFS. As a result, two key issues come to light: 1) multiple government entities are working at cross purposes, leaving the citizen-owner in a confusing position; and 2) no government entity is protecting the citizen-owner or the general public's interests and general welfare by ensuring that crib docks are built in compliance with the design and construction code. Crib docks, by virtue of their design, are in conflict with both of the MDEQ and USACE missions, so both governmental agencies strongly discourage their construction. However, both the USFS and the MDNR strongly believe there is sufficient experiential evidence that shows submerged crib-based structures promote sport fish population growth. Hence, they support the construction of crib docks. To the citizen-dock owner, these opposing positions present a confusing, frustrating situation.

The qualitative findings also showed that no building code requirements, state or local, were being considered in the review and approval of crib dock construction permit applications. In Michigan, the local government is responsible for enforcement of the state building code, but the docks are on state land and there is no provision in the Michigan Residential Code that is directly applied to crib docks. The discussion of recommended crib dock approval standards covered the environmental conclusions of this study and how they should be considered in the evaluation of an owner's application for approval to build a crib dock, while the discussion of construction standards addressed structural design considerations that could be enforced by the MDEQ inspectors during the construction and subsequent maintenance of crib docks in protection of dock owners and the public welfare

against poorly designed or constructed crib docks. These standards, if adopted, would significantly reduce a crib dock's negative ecological "footprint," make them safer and more durable, and still achieve the same serviceability desired by requesting dock owners.

The two primary environmental objections to crib docks raised by the MDEQ was their occupation of Great Lakes bottomland and their interference with littoral flow. The further apart the cribs are placed, the less bottomland they occupy and the less they interfere with littoral flow. The accepted standard of 11 feet appears to be adequate. However, increased spacing would often allow comparable docks to be constructed with fewer cribs, and should be considered when it is possible to employ fewer cribs. A compounding factor would be how well the area is protected from wave action, size and type of boat. The docks protect boats as well as providing a platform to access them. It would also allow the MDEQ to require that proposed docks be designed and built so as to achieve at least 40% clear flow space and accommodate the natural littoral flow with a standard crib spacing of at least 11 feet.

Beyond footprint and littoral flow, concerns were also identified with regard to crib dock ballast and safety markings. The dock cribs throughout the research area were loaded with unwashed, crushed quarry limestone ranging in size from 6 to 12" in diameter, or field stone. The use of unwashed or unscreened ballast minimizes the interstitial habitat space provided by the dock cribs, because some of the space is filled with fines. To protect the environment and maximize the wildlife habitat these docks provide, the MDEQ should require that the crib ballast stone be washed or screened, and sized 6 inches in diameter or more. Because of the crib and ballast design, crib docks are clearly a waterway obstruction. However, the Corps approves crib docks for construction in concert with the joint



USACE-MDEQ approval process without requiring that they are clearly marked to minimize the obstruction hazard. All permanent docks, to include crib docks, should be required to have reflective and lighting devices to mark how far the dock extends into a waterway.

The findings also showed that many items specific to permanent dock structures are not addressed by the Michigan Residential Code. These permanent dock specific issues should be addressed in the local government's building ordinances, in this case the Clark Township Building Ordinance, Article IX, Sections 903 and 904 dealing with accessory structures and boathouses. These are structural issues peculiar to permanent dock structures that should be covered by local building ordinances. In particular, local governments with a significant amount of shoreline should consider adopting aspects of the Corps of Engineers Engineering Regulation (ER) 1130-2-406, Shoreline Management at Civil Works Projects, which establishes standards for docks and other shoreline structures. Adoption of these standards by local governments with jurisdiction over shoreline areas would make their permanent docks much safer.

The applicability of these conclusions was limited with regard to the geographic and demographic constraints of the research area, the construct constraints of the study methodology employed, and the limited projectability due to the dock sample size. To address these limitations and build upon the conclusions, the study provided recommendations for government action and recommendations for further study. Recommendations for government action include actions that should be taken on the part of specified federal and state agencies to address construction permitting issues with regard to crib docks identified in the course of this research study. The recommended actions include the following: the MDEQ and USACE should develop crib dock approval standards; the

MDEQ and MDNR should resolve their conflicting positions on crib docks and address the result in the approval standards; Michigan state government needs to develop a design and construction standard that incorporates applicable portions of the Michigan Residential Code and USACE to permanent docks, including crib docks; and a state model local township zoning ordinance needs to be developed to cover shoreline structural issues peculiar to permanent docks like crib docks. A recommended set of crib dock permit and construction standards based on this study is provided at Appendix 9. The recommendations for further study addressed issues that were identified in the course this study that require additional research to explore questions raised, validate findings made, or expand upon the conclusions drawn from those findings. These recommendations included determining the applicability of the findings to crib dock construction beyond the research area; developing a ground anchorage versus dock site exposure risk assessment nomograph for determining the ground anchorage required by a specific site; and evaluating the freshwater littoral ecosystem impacts, positive and negative, of crib docks.

These conclusions have broader implications as the interface between individual property rights and societal environmental priorities continues to be a point of conflict and dissatisfaction. In this case, property owners have invested significant personal wealth to obtain highly desirable shorefront property only to be told that they cannot build the dock that suits their needs and desires. When asked for the specific reasons for the disapproval, none are available due to the vague nature of the permit approval standards and conditions. Issues of this nature will become increasingly significant as public and governmental pressure related to environmental issues continues to grow. These results will be provided to the appropriate agencies for consideration and codification of the crib dock approval process.

The findings add to the existing knowledge about resolving multiple jurisdictional construction issues in the era of sustainable construction technologies in support of residential construction, both permanent and seasonal, in the ecologically sensitive Great Lakes region.

## REFERENCES

- American Society of Civil Engineers (ASCE). (1994). *Planning and Design Guidelines for Small Craft Harbors*. New York: American Society of Civil Engineers.
- Andrews, R. N. L. (1999). *Managing the Environment, Managing Ourselves: A History of American Environmental Policy* (First ed.). New Haven, CT: Yale University Press.
- Ardizzone, K. A., & Wyckoff, M. A. (2003). *Filling the Gaps: Environmental Protection Options for Local Governments*. Retrieved. 23 October 2006 from:  
[http://www.michigan.gov/deq/0,1607,7-135-3313\\_3677\\_3696-73358--,00.html](http://www.michigan.gov/deq/0,1607,7-135-3313_3677_3696-73358--,00.html).
- Bassett, C. E. (1994). Use and Evaluation of Fish Habitat Structures in Lakes of the Eastern United States by the USDA Forest Service. *Bulletin of Marine Science*, 55(2-3), 12.  
Retrieved 24 April 2008 from <http://www>.
- Beauchamp, D. A., Byron, E. R., & Wurtsbaugh, W. A. (1994). Summer Habitat Use by Littoral-Zone Fishes in Lake Tahoe and the Effects of Shoreline Structures. *North American Journal of Fisheries Management*, 14, 385-394.
- Brown, A. M. (1998). *Shoreline Residential Development and Physical Habitat Influences on Fish Density at the Lake Edge of Lake Joseph, Ontario*. Unpublished master's thesis, University of Toronto, Toronto, ON, CA.
- Burns, M. (1999). *The Dock Manual: Designing, Building, Maintaining*. North Adams, MA: Storey Publishing.
- Burns, M. (2004). *The Dock Primer: A Cottager's Guide to Waterfront Friendly Docks*. Retrieved. 4 November 2005 from [http://www.dfo-mpo.gc.ca/regions/CENTRAL/pub/dock-quais-on/pdf/dock-quais-on\\_e.pdf](http://www.dfo-mpo.gc.ca/regions/CENTRAL/pub/dock-quais-on/pdf/dock-quais-on_e.pdf).

- Campbell, D. T., & Fisk, D. W. (1959). Convergent and discriminant validation by multitrait-multimethod matrix. *Psychological Bulletin*, 56(2), 28.
- Canadian Department of Fisheries and Oceans (CDFO). (2005). *Habitat Management Program, Dock and Boathouse Construction*. Retrieved 4 November 2005 from [http://www.dfo-mpo.gc.ca/regions/central/habitat/os-eo/prov-terr/on/os-eo08\\_e.htm](http://www.dfo-mpo.gc.ca/regions/central/habitat/os-eo/prov-terr/on/os-eo08_e.htm)
- Clark Township Boathouse Ordinance, Clark Township (MI) Zoning Ordinance, Article IX - Supplementary Regulations, Section 905. (2002).
- Crawford, D. M., Woodward, Bessie M., Hatfield, C. A. . (2000). *Comparison of Wood Preservatives in Stake Tests*. Retrieved 23 July 2008 from <http://www.fpl.fs.fed.us/documnts/fplrn/fplrn002.pdf>.
- Creswell, J. W. (1998). *Qualitative Inquiry and Research Design: Choosing Among the Five Traditions*. Thousand Oaks, CA: SAGE Publications, Inc.
- Creswell, J. W. (2003). *Research Design: Qualitative, Quantitative, and Mixed Methods Approaches*. Thousand Oaks, CA: Sage Publications, Inc.
- Creswell, J. W., & Plano Clark, V. L. (2007). *Designing and Conducting Mixed Methods Research*. Thousand Oaks, CA: Sage Publications, Inc.
- Denzin, N. K., & Lincoln, Y. S. (Eds.). (1998). *Strategies of Qualitative Inquiry*. Thousand Oaks, CA: Sage Publication, Inc.
- Derbyshire, K. (2006). Fisheries Guidelines for Fish-Friendly Structures. Department of Primary Industries and Fisheries. State Government of Queensland, Australia (Ed.) (6th ed., pp. 55): Manager, DPI&F Publications.

- Driscoll, D. L., Appiah-Yeboah, A., Salib, P., & Rupert, D. J. (2007). Merging Qualitative and Quantitative Data in Mixed Methods Research: How To and Why Not. *Ecological and Environmental Anthropology*, 3(1), 10.
- Emery, M. R. (1996). *Non-timber Forest Products and Livelihoods in Michigan's Upper Peninsula*. [Electronic Version] U.S. Department of Agriculture – Forest Service: Northeastern Research Station. Retrieved 4 November 2005 from [http://www.ncrs.fs.fed.us/pubs/gtr/other/gtr-nc217/gtr\\_nc217page%20023.pdf](http://www.ncrs.fs.fed.us/pubs/gtr/other/gtr-nc217/gtr_nc217page%20023.pdf)
- Fraenkel, J. R., & Wallen, N. E. (2003). *How to Design and Evaluate Research in Education* (Fifth ed.). Boston: McGraw Hill Higher Education.
- Francis, S. W., & Stone, J. B. (1998). *The International Building Code and Its Impact on Wood-Frame Design and Construction*. Paper presented at the 1998 ASAE Annual International Meeting. Retrieved 14 August 2008 from <http://www.awc.org/Publications/papers/ASAE984007.pdf>.
- Ghosh, S. K. (2002). The Building Code Process: An Introduction. *PCI Journal (Precast Concrete Institute)*(July-August 2002), 4.
- Gringras, P. (2005, March 2). Sportsmen Create Fish Habitat at Brevort Lake. *The St. Ignace News*. Retrieved 26 November 2007 from <http://www.stignacenews.com/news/2005/0302/News/020.html>
- Gringras, P. (2006, July 6). State Police Dive Team Finds Abundant Fish at Brevort lake Cribs. *The St. Ignace News*. Retrieved 26 November 2007 from [http://www.stignacenews.com/news/2006/0706/Front\\_Page/056.html](http://www.stignacenews.com/news/2006/0706/Front_Page/056.html)
- Grover, F. R. (1911). *A Brief History of Les Cheneaux Islands*. Evanston, IL: Bowman Publishing Company.

- Guide to Residential Construction* (2007). City of Sault Ste Marie, MI. Retrieved 20 November 2007 from <http://www.sault-sainte-marie.mi.us/Administration/bldg/>.
- Hammitt, J. K., Belsky, E. S., Levy, J. I., & Graham, J. D. (1999). Residential Building Codes, Affordability, and Health Protection: A Risk-Tradeoff Approach. *Risk Analysis*, 19(6), 22.
- Horne, A. J., & Goldman, C. R. (1994). *Limnology* (Second ed.). New York, NY: McGraw-Hill, Inc.
- Isle Royale National Park (IRNP) (2004). *Environmental Assessment: Replacement of Docks at Tobin Harbor*. Retrieved 4 November 2005 from <http://nps.gov/archive/isro/Plans%20and%20Reports/EA-Tobin%20Harbor%20Dock.pdf>
- Johns, C. H. W. (1911). *The Oldest Code of Laws in the World: The Code of Laws Promulgated by Hammurabi, King of Babylon* (C. H. W. Johns, Trans.). Edinburgh: T. & T. Clark.
- Johnson, R. B., & Onwuegbuzie, A. J. (2004). Mixed Methods Research: A Research Paradigm Whose Time Has Come. *Educational Researcher*, 33(7), 13.
- Johnson, R. B., Onwuegbuzie, A. J., & Turner, L. A. (2007). Toward a Definition of Mixed Methods Research. *Journal of Mixed Methods Research*, 1(2), 22.
- Lake and Lakeshore Protection Regulations, Flathead County, MT. (1992, 2002). Flathead County Planning & Zoning Office, Kalispell, MT. Retrieved 15 September 2007 from <http://www.co.flathead.mt.us/fcpz/lakeregs/county/fclkregs.pdf>.
- Lebow, S. (2007). A primer on wood as dock construction material. *Marina Dock Age*, 4. Retrieved 23 July 2008 from [http://www.fpl.fs.fed.us/documnts/pdf2007/fpl\\_2007\\_lebow002.pdf](http://www.fpl.fs.fed.us/documnts/pdf2007/fpl_2007_lebow002.pdf)

- Lew, H. S., Bukowski, R. W., & Carino, N. J. (2005). *Federal Building and Fire Safety Investigation of the World Trade Center Disaster: Design, Construction, and Maintenance of Structural and Life Safety Systems (Draft)*. Retrieved 19 September 2007 from <http://wtc.nist.gov/NISTNCSTAR1-1.pdf>.
- Listokin, D., & Hattis, D. B. (2005). Building Codes and Housing. *Cityscape: A Journal of Policy Development and Research*, 8(1), 47. Retrieved 20 September 2007 from <http://www.huduser.org/periodicals/cityscpe/vol8num1/ch2.html>
- Marsh, W. M. (2005). *Landscape Planning: Environmental Applications* (Fourth ed.). Hoboken, NJ: John Wiley & Sons, Inc.
- Maxim, P. S. (1999). *Quantitative Research Methods in the Social Sciences*. New York, NY: Oxford University Press, Inc.
- McNeill, C., & Promaine, A. (2007). *Reporting on Ecosystem Health: A State of the Park Report for Fathom Five National Marine Park of Canada*. Paper presented at the The Science and Management of Protected Areas Association. Retrieved 18 December 2007 from <http://www.sampaa.org/PDF/ch13/13.11.pdf>.
- Michigan Department of Environmental Quality (MDEQ). (2006). *MDEQ/USACE Joint Permit Application Training Manual*. Retrieved 18 December 2007 from [http://www.michigan.gov/deq/0,1607,7-135-3307\\_29692\\_24403-76158--,00.html](http://www.michigan.gov/deq/0,1607,7-135-3307_29692_24403-76158--,00.html).
- Michigan Department of Labor and Economic Growth (MDLEG). (2003). *Michigan Residential Code*. ICC Publications, Inc.
- Michigan Department of Labor and Economic Growth (MDLEG). (2007). *Building Permit Information*. Retrieved. 20 November 2007 from [http://www.michigan.gov/dleg/0,1607,7-154-10575\\_17394\\_17412-42951--,00.html](http://www.michigan.gov/dleg/0,1607,7-154-10575_17394_17412-42951--,00.html).



- Michigan Department of Natural Resources (MDNR). (2007). *DNR Home*. Retrieved 16 January 1008 from <http://www.michigan.gov/dnr>.
- Moore, D. S., & McCabe, G. P. (2003). *Introduction to the Practice of Statistics* (Fourth ed.). New York: W. H. Freeman and Company.
- Muvdi, B. B., Al-Khafaji, A. W., & McNabb, J. W. (1996). *Statics for Engineers*. New York, NY: Springer-Verlag New York, Inc.
- National Oceanographic and Atmospheric Administration (NOAA). (1998). *Climatic Wind Data for the United States, 1930-1996*. Retrieved 14 March 2008, from <http://www.ncdc.noaa.gov>.
- National Oceanographic and Atmospheric Administration (NOAA). (2008). Station DTLM4 - 9075099 - De Tour Village, MI. *National Data Buoy Center* Retrieved 27 May 2008, from [http://www.noaa.gov/station\\_page.php?station=dtlm4](http://www.noaa.gov/station_page.php?station=dtlm4)
- National Oceanographic and Atmospheric Administration (NOAA) Coast Pilot 6. (2007). *Great Lakes: Lakes Ontario, Erie, Huron, Michigan and Superior and St. Lawrence River*. Retrieved 13 September 2007, from <http://nauticalcharts.noaa.gov/nsd/coastpilot6.htm>.
- Natural Resources and Environmental Protection Act (NREPA), Act 451 of 1994 Michigan C.F.R. (1994). Part 303: Wetlands Protection.
- Natural Resources and Environmental Protection Act (NREPA), Act 451 of 1994 Michigan C.F.R. (1994). Part 323: Shorelands Protection and Management.
- Natural Resources and Environmental Protection Act (NREPA), Act 451 of 1994 Michigan C.F.R. (1994). Part 325: Great Lakes Submerged Lands.

- Neese, J., Eriksson, M., & Vachowski, B. (2002). *U.S. Department of the Interior, Forest Service, Technical Bulletin 2E22A44 - Floating Trail Bridges and Docks*. Retrieved 23 September 2007 from <http://www.fhwa.dot.gov/environment/Fspubs/02232812/index.htm>.
- New York State Office of Real Property Services. (2002). *Assessor's Manual: Residential, Farm, and Vacant Land*. Retrieved 3 January 2008 from <http://www.orps.state.ny.us/assessor/manuals/assesrmanual.cfm>.
- Perdue, W. C., Stone, L. A., & Gostin, L. O. (2003). The Built Environment and Its Relationship to the Public's Health: The Legal Framework. *American Journal of Public Health, 93*(9), 5. Retrieved 27 October 2007 from <http://www.ajph.org/cgi/content/abstract/93/9/1390>
- Pittman, P. M. (1984). *The Les Cheneaux Chronicles: Anatomy of a Community* (First ed.). Charlevoix, MI: Peach Mountain Press.
- Rea, L. M., & Parker, R. A. (1997). *Designing and Conducting Survey Research: A Comprehensive Guide* (Second ed.). San Francisco, CA: Jossey-Bass Inc.
- Residential Building Code, City of Ann Arbor Ordinance No. 33-86. (1986, 1995, 2004). Retrieved 25 June 08. from: [http://www.a2gov.org/government/communityservices/planninganddevelopment/building/Documents/building\\_info\\_decks.pdf](http://www.a2gov.org/government/communityservices/planninganddevelopment/building/Documents/building_info_decks.pdf).
- Rivers and Harbors Appropriation Act of 1899, Chap 425, Sec. 9, 30 Stat. 1151. 33 U.S.C. § 401 (1899).
- Schuster, R. L.; Jones, M. V.; Smart, S. M.; Sack, R. L. (1973). *A study and analysis of timber crib retaining walls*. University of Idaho, College of Engineering, Civil Engineering Report, 73-1. Moscow, ID.

- Smith, R. L. (1994). *A hierarchical analysis of factors affecting the adoption and marketing of timber bridges*. Unpublished Dissertation, Virginia Polytechnic Institute and State University, Blacksburg, VA.
- Solomon, R. E. (1994). *Automatic Sprinkler Systems Handbook* (6 ed.). Quincy, MA: National Fire Protection Association.
- Syal, M., & Shay, C. (2001). *Implementing a Building Rehabilitation Code in Michigan*: Michigan State University, Center for Community & Economic Development. Retrieved 19 November 2007 from <http://www.ced.msu.edu/hsreportspg.html>
- U.S. Army Coastal Engineering Research Center. (1977). *Shore Protection Manual*.
- U.S. Army Corps of Engineers - Mobile\_District. (2004). *Lake Sidney Lanier Shoreline Management Plan*. Retrieved 8 September 2008 from <http://lanier.sam.usace.army.mil/brochures/2004FinalSMP.pdf>.
- U.S. Department of Agriculture, Natural Resources Conservation Service (NRCS). (1993). *Soil Survey Manual*. Retrieved 31 March 2008, from <http://soils.usda.gov/technical/manual>
- U.S. Environmental Protection Agency History Office. (1972). *The Challenge of the Environment: A Primer on EPA's Statutory Authority*. Retrieved 24 September 2008. from <http://www.epa.gov/history>.
- Wortley, C. A. (1982). Ice Engineering Design of Marine Piling and Piers. *Journal of the Technical Councils of ASCE*, 108-TC2(November 1982), 14.
- Western Wood Preservers Institute (WWPI). (2006). Treated Wood in Aquatic Environments. Retrieved 6 August 2008 from <http://www.wwpinstitute.org>

APPENDICES

Appendix A - MDEQ – Great Lakes Shoreline Management General Permit.  
USACE – Application for Minor Shore Activities Application Form and  
Instructions



Michigan Department of Environmental Quality – Great Lakes Shoreline Management General Permit  
U.S. Army Corps of Engineers – Application for Minor Shore Activities  
Application Form and Instructions



This application may be used for shoreline management activities located above the water's edge and below the ordinary high water mark (OHWM) on the bottomlands of the entire Great Lakes shoreline, including Lake St. Clair.

This application is for the following types of projects, provided they fit within the limits of the Michigan Department of Environmental Quality (MDEQ) General Permit (GP) and the U.S. Army Corps of Engineers (USACE) regional permit (RP) categories:

- Leveling and grooming of sand in areas free of vegetation.
- Construction and maintenance of a temporary path in areas free of vegetation using on-site materials.
- Mowing a pathway.
- Mowing a recreational area.
- Mowing in previously mowed areas of Saginaw and Grand Traverse Bays, if the original mowing was done in compliance with the Natural Resources and Environmental Protection Act, 1994, PA 451, as amended (NREPA).
- Mowing of invasive or non-native species as part of a vegetation control plan in accordance with recommendations from the MDEQ.

A detailed description of the activities authorized under the GP may be accessed at [www.michigan.gov/deq/wetlands](http://www.michigan.gov/deq/wetlands). Activities qualifying for issuance under the RP can be found at [www.lre.usace.army.mil/who/regulatoryoffice/hottopics/greatlakescoastalwetlands](http://www.lre.usace.army.mil/who/regulatoryoffice/hottopics/greatlakescoastalwetlands).

Activities below the water's edge, vegetation removal, and beach nourishment are not authorized by the GP/RP categories. Individuals wishing to conduct these activities must complete the joint permit application, available at [www.michigan.gov/jointpermit](http://www.michigan.gov/jointpermit). Application of herbicide as part of an invasive or non-native species control plan requires a permit from the MDEQ's Aquatic Nuisance Control Program. See [www.michigan.gov/inlandlakes](http://www.michigan.gov/inlandlakes).

**Directions for completing the Great Lakes Shoreline Management General Permit Application Form:**

Make sure you:

- Fill out all boxes pertinent to your project.
- Provide the township, range, and section numbers required in the Property Location and Description section.
- Print your name, sign, and date your application on Page 3.
- Provide a letter of authorization if the legal property owner is not the individual who signs the application, or if multiple adjacent property owners are applying for authorization under a single application. A letter of authorization is a letter from the legal landowner(s) authorizing the applicant or agent to apply for the project. The letter should include the signature from the landowner, the project site address and a short description of the project.
- If a path or recreation area is proposed, stake or flag the project area for a potential site inspection.
- An application fee of \$50 is required for projects that propose mowing alone. All other projects require a \$100 fee.
- If the application fee will be paid by check, submit all application materials to:
  - MDEQ, LWMD-PCU
  - P.O. Box 30204,
  - Lansing, MI 48909-7704.

If the fee will be paid using a credit card or electronic funds transfer form, you may submit all application materials to the address above, or to the appropriate MDEQ district office, as shown at [www.michigan.gov/deqlwmd](http://www.michigan.gov/deqlwmd).

**Provide the following maps, drawings, and photographs with adequate detail for review.**

- **Project Location Map:**  
A map to the proposed project location that includes all streets, roads, intersections, highways, or cross-roads to the project. Include written directions from a major intersection. Do not assume MDEQ/USACE field staff will know where your project is located.
- **Project Site Plan:**  
Overhead drawings of the proposed project to scale or with length and width dimensions. Show property lines, the water's edge, approximate OHWM, and any nearby buildings or other landmarks on the site plan.
- **Photographs of the project area:**  
Photos will aid MDEQ/USACE field staff in the prompt review of your application. If possible, provide photos of the proposed work area showing vegetation and the shoreline. All photos must be labeled with the applicant's name, the date the photo was taken, and a description of what the photo shows. Photo locations should be indicated on the site plan.

<b>AGENCY USE</b>		<b>Great Lakes Shoreline Management MDEQ General Permit and USACE Regional Permit Application Form</b>		Date Received:	MDEQ File Number:
					USACE File Number:
					MDEQ District Office:
					Fee received:

<b>Property Owner</b>	<b>Agent/Contractor</b>
Property Owner (For multiple applicants, include authorization letters):	Agent/Contractor:
Contact Person:	Contact Person:
Address:	Address:
City:                      State:                      Zip:	City:                      State:                      Zip:
Phone:                      Fax:	Phone:                      Fax:
Email:	Email:

<b>Project Location and Description</b>				
Property Address:	City/Village:	Zip Code:		
Township Name:	County:	Town:	Range:	Section:
Directions to property from main intersection (Attach a location map of the property):				
Describe proposed project and associated activities, construction sequence and construction methods (Attach site plans and photos):				
Are these activities proposed in a designated Environmental Area, as defined by Part 323 of the NREPA? <input type="checkbox"/> yes <input type="checkbox"/> no <input type="checkbox"/> unknown		Have any mowing activities taken place in the project area? <input type="checkbox"/> yes <input type="checkbox"/> no		
Have any vegetation removal activities taken place in the project area? <input type="checkbox"/> yes <input type="checkbox"/> no		If yes, was vegetation removed under a permit or an MDEQ director's letter? <input type="checkbox"/> yes <input type="checkbox"/> no If yes, list DEQ File Number and USACE file number:		

**Activities in Areas Free of Vegetation:**  
Check each activity proposed and provide requested information. To calculate volume in cubic yards (cu.yds.), multiply average length in feet (ft) times the average width (ft) times the average depth (ft) and divide by 27.

<input type="checkbox"/> Leveling sand	Dimensions of work area: Length:                      Width:                      Volume (cu.yds.):
<input type="checkbox"/> Grooming sand (Including debris removal)	Dimensions of work area: Length:                      Width:                      Type of Debris to be removed (e.g., algae, animal and fish carcasses, garbage, etc): Debris disposal method and location: Grooming Depth (not to exceed 4 inches):
<input type="checkbox"/> Construction and maintenance of a path using on-site materials obtained from non-vegetated bottomlands or upland. (For paths in vegetated areas, use the Joint Permit application)	Path dimensions (not to exceed 6 feet in width for each property owner or 10 feet in width for public access areas or commercial hotels): Length:                      Width:                      Volume (cu.yds.): (For public access areas and commercial hotels only) Property width (feet of lake frontage): Number of paths proposed:

Great Lakes Shoreline Management Application	EQP 2709 (Rev. 1/2008) Page 2 of 3
--	---------------------------------------

Mowing Vegetation (USACE will not review this portion): Check each activity proposed and provide requested information.		
<input type="checkbox"/> Mowing for a pathway	Proposed path dimensions (not to exceed 10 feet in width): Length: _____ Width: _____	
	Proposed mowing height (not less than 4 inches): _____	
	Vegetation collection methods and disposal location, if proposed: _____	
<input type="checkbox"/> Mowing for a recreation area	Proposed dimensions (not to exceed 400 square feet): Length: _____ Width: _____	
	Proposed Mowing Height (not less than 4 inches): _____	
	Vegetation collection methods and disposal location, if proposed: _____	
<input type="checkbox"/> Mowing in previously mowed areas of Saginaw and Grand Traverse Bays	Dimensions of previously mowed area: Length: _____ Width: _____	
	Dimensions of proposed mowing area: Length: _____ Width: _____	
	Dimensions of property: Length: _____ Width: _____	
	Proposed mowing height (not less than 4 inches): _____	
	Vegetation collection methods and disposal location, if proposed: _____	
<p><b>Mowing Invasive or Non-native Species:</b> Check below if conducting this activity. The purpose of an invasive species control program is to re-establish native vegetation on the shoreline. Creation of manicured lawns or complete removal of vegetation is not authorized. If controlling phragmites, please read the MDEQ recommendation for Phragmites control and follow the guidelines for control plan applications available at <a href="http://www.michigan.gov/deawetlands">www.michigan.gov/deawetlands</a>.</p> <p>Herbicide treatments require a permit from the Aquatic Nuisance Control (ANC) Program. See <a href="http://www.michigan.gov/inlandlakes">www.michigan.gov/inlandlakes</a> for the permit application.</p>		
<input type="checkbox"/> Mowing Invasive or non-native species as part of a vegetation control plan	Dimensions of proposed mowing area: Length: _____ Width: _____	
	Invasive or non-native species to be removed: _____	
	Vegetation collection methods and disposal location, if proposed: _____	
	Date of ANC application submittal: _____	
	ANC permit number: _____	
<p><b>APPLICANT'S CERTIFICATION: READ CAREFULLY BEFORE SIGNING</b> I am applying for a permit(s) to authorize the activities described herein. I certify that I am familiar with the information contained in this application, that it is true and accurate, and, to the best of my knowledge, is in compliance with the State <i>Coastal Zone Management Program</i> and the <i>National Flood Insurance Program</i>. I understand that there are penalties for submitting false information and that any permit issued pursuant to this application may be revoked if information on this application is untrue. I certify that I have the authority to undertake the activities proposed in this application. By signing this application, I agree to allow representatives of the MDEQ and USACE to enter upon said property in order to inspect the proposed activity site and the completed project. I understand that I must obtain all other necessary local, county, state, or federal permits and that the granting of other permits by local, county, state, or federal agencies does not release me from the requirements of obtaining the permit requested herein before commencing the activity. I understand that the payment of the application fee does not guarantee the issuance of a permit.</p>		
Property Owner's Printed Name	Property Owner's Signature	Date
Great Lakes Shoreline Management Application		EQP 2709 (Rev. 1/2008) Page 3 of 3



Appendix B - Crib Dock Contractor Interview Guide

## CRIB DOCK BUILDER INTERVIEW GUIDE

Identification			
Date & Time:		Location:	
Primary Subj:		Company:	
Position:		City:	
Cell Phone:		Telephone:	
Others present:			

### I. Introduction:

- Brian Hoxie.
- Student from EMU studying crib docks.
- Like to talk with you about how crib docks are:
  - Selected.
  - Designed & costed.
  - Environmental issues.
  - Construction & maintenance.
- Successful completion of this work will likely enhance the demand for crib docks.
- Informed Consent Form

### II. Dock building business and dock style selection information:

1. How long have you been in the marine and dock construction business?
  
2. When you meet with a new customer, what questions do you ask to determine what they need?
  
3. What dockage options do you offer them in this region?

**CRIB DOCK BUILDER INTERVIEW GUIDE***Brian Hoxie*  
Page 2

4. What are the trade-offs?
  - Site layout issues.
  
  - Construction costs.
  
  - Maintenance costs.
  
  - Expected seasons of service.
  
5. How often are crib docks the option of choice? Why?

**III. Crib dock design and construction planning information:**

6. How do you typically design and build your crib docks?
  
  
  
  
  
  
  
  
  
  
7. What are the key issues and concerns?
  - a) Dock shape, design, and orientation.
  
  
  
  
  
  
  
  - b) Site preparation and dredging.
  
  
  
  
  
  
  
  - c) Ground anchors, pilings, and settling control measures.
  
  
  
  
  
  
  
  - d) Structural materials used. Hardware options?
  
  
  
  
  
  
  
  - e) Lumber selection. Type of wood? Pressure treated? Kinds of treatment?

- f) Joint connection methods used.
- g) Fill specifications and installation method used.
- 8. How do you cost out a crib dock estimate? What are the cost drivers?
- 9. Duration estimating parameters? How long do various tasks take?
- 10. How do current construction techniques compare with the past methods?

**IV. Environmental issues:**

- 11. What are the DNR, DEQ, and USACE specifications and permit requirements:
  - a) For docks in general?
  - b) For crib docks?
  - c) Are they reasonable? Why? Why not?
- 12. What are the specific permit requirements for crib docks?
  - a) What paperwork is required?
  - b) How much do the permits cost?

c) How long does the process take?

13. Do you avoid permit issues? Why? Why not? What is the risk?

14. What environmental issues come into play?

- a) Site selection, orientation, and footprint.
- b) Erosion and sedimentation control measures.
- c) Materials selection.
- d) Dredge material disposal.

**V. Crib dock construction process information:**

15. How does your crib dock construction process typically proceed?

16. What are the key issues? Concerns?

- a) Site planning, layout, and preparation.
- b) Environmental impact control measures typically used. Sediment screens?
- c) Crib assembly, placement, fill, and anchorage.
- d) Superstructure construction and installation.
- e) Dock hardware, approach, and railings installation.

**CRIB DOCK BUILDER INTERVIEW GUIDE***Brian Hoxie*  
Page 5

- f) Site landscaping, clean-up and project record keeping.

**VI. Dock construction follow-up:**

17. What kinds of construction follow-up services do you provide for crib docks.
18. What are the typical maintenance requirements for crib docks in this region?
19. What construction measures do you take to minimize maintenance requirements?
20. Could you please identify some crib docks you built that I can go see:
- a) One that you completed in the last year that demonstrates current design and construction techniques.
  - b) The oldest serviceable one or at least one that has endured a number of seasons.
  - c) One that has failed due to structural issues.

**IV. Thank you & follow-up:**

- Thanks for your assistance and cooperation.
- Give a business card:
  - write cell phone number: (734) 417-7284
  - Local phone: Dan Fields (Cadogen Point): (906) 484-1095
- If anything comes to mind:
  - Pls call or stop by at Cadogen Pt.
  - E-mail: bhoxie@emich.edu
- Do you have any suggestions for me:
  - Who to see?
  - What to see?
  - Issues to pursue?

Appendix C - Crib Dock Owner Interview Guide

**CRIB DOCK OWNER  
INTERVIEW GUIDE**

1. How satisfied are you with your crib dock? Why?
2. What are their advantages and disadvantages in comparison to other options?
3. What are the maintenance and upkeep requirements?
4. If you had to do all over again, would you build another crib dock? Why? Why not?



Appendix D – Government Official Interview Guide

## INTERVIEW GUIDE

Identification			
Subject:		Organization:	
Position:		Telephone:	
Date & Time:		Location:	
Notes:			

### Introduction:

- Thank for agreeing to see me.
- Brian Hoxie – business card.
  - Retired Army officer; 25 yr in USACE in troop construction.
  - EMU administrator, instructor, & a doctoral student.
  - Doing dissertation on crib docks, interested in sustainable construction.
  - No vested interest in any particular position; no hidden agenda.
  - Spent portions of last three summers in UP.
  - Talking with folks & looking at docks.
  - Did talk with UP MDEQ in Aug 06
- Like to follow up on that conversation:
  - Now have a more complete understanding.
  - Crib dock applications:
    - Compiled & processed.
    - Reviewed & approved.
    - Primary considerations, issues, & concerns.
    - Environmental vs structural.

### Interview:

1. How does the application to build a crib dock go? What are the steps? How long? Cost?



## INTERVIEW GUIDE

Subject:  
Organization:

7. When is a crib dock proposal a major vs minor permit?

8. Crib dock specific design & construction specifications?

- Crib footprint?
- Crib spacing?
- Crib spacing at OHWM?
- Crib ballast?
- Simple dock vs boathouse?

9. What causes an application to be denied?

10. What recourse does the applicant have?

## INTERVIEW GUIDE

Subject:

Organization:

11. What about crib vs sheet piling vs floating docks?

12. What formal research can I cite on negative affects of lake bottom occupation?

13. What if anything does the process need?

14. What does the future hold? Can I do anything for you?

Appendix E - Human Subjects Review Committee approval



## EASTERN MICHIGAN UNIVERSITY

June 21, 2006

Mr. Brian Hoxie  
School of Engineering Technology

Dear Brian:

The Human Subjects Institutional Review Board (IRB) of Eastern Michigan University has granted approval to your proposal, "Crib Docks Revisited."

After careful review of your completion application, the IRB determined that the rights and welfare of the individual subjects involved in this research are carefully guarded. Additionally, the methods used to obtain informed consent are appropriate, and the individuals participating in your study are not at a risk.

You are reminded of your obligation to advise the IRB of any change in the protocol that might alter your research in any manner that differs from that upon which this approval is based. Approval of this project applies for one year from the date of this letter. If your data collection continues beyond the one-year period, you must apply for a renewal.

On behalf of the Human Subjects Committee, I wish you success in conducting your research.

Sincerely,

A handwritten signature in black ink, appearing to read "B. Holkeboer".

Robert Holkeboer  
Associate Vice President  
Graduate Studies & Research  
Human Subjects Committee

Copy: Daniel Fields, School of Engineering Technology

Appendix F - Crib Dock Site Data Collection Form



## CRIB DOCK DATA RECORD

<b>Sequence No:</b>	<b>SITE IDENTIFICATION</b>			<b>1<sup>st</sup> Visit:</b> <small>(yr-mo-day)</small>
Builder:		City:		
Owner:		Address:		
Telephone:		City:		
Site address:		City:		
Township:		Section #:		
Lake/Region:		Topo Map:		
Landmarks:				
<b>Site visits:</b>				
	<i>Date</i> <small>(yr-mo-day)</small>	<i>Time</i> <small>(24hr)</small>	<i>Weather</i> <small>(visibility / wind / precipitation)</small>	<i>Notes</i>
1				
2				
3				
4				
<b>Site Timeline:</b>				
	<i>Date:</i>	<i>Notes:</i>		
Work Start:				
Work Completed:				
Cost:				
Initial Owner took possession:				
Subsequent Owner took possession:				
Subsequent Owner took possession:				
1 <sup>st</sup> major rebuild:				
2 <sup>nd</sup> major rebuild:				
<b>Construction Permits/Inspections:</b>				
<i>Date</i> <small>(yr-mo-day)</small>	<i>Agency</i>	<i>Purpose</i>	<i>Results / Notes</i>	
<b>Other Notes:</b>				

<b>SITE DESCRIPTION</b> <i>(see sketches on pg 5)</i>	
<b>Shore / Riparian Area Description:</b>	
Site purpose:	
Dock location:	
Dock Usage:	
Dock Shape:	
Prevailing winds:	
Shoreline orientation:	
Bank shape:	
Vegetation:	
Soil Composition:	
Other notes:	
<b>Off-shore / Littoral Area Description:</b>	
Bottom slope:	Depth 10' from shore = Depth 20' from shore = Depth 30' from shore =
Bottom soil composition:	
Vegetation:	
Other notes:	

Site No:

Page 3 of 8

**DOCK CONSTRUCTION***(see sketches on pg 6)***Crib Design:**

Timbers used: <i>(finished / rough / size)</i>	
Fill used: <i>(type / size)</i>	
Crib placement technique used:	
Timber connection: <i>(cable/spike / other)</i>	
Tier spacing: <i>(between / from shore)</i>	
Other notes:	

**Ground Anchorage:**

Style: <i>(piling - placement - none)</i>	
Piling orientation: <i>(butt vs taper down)</i>	
Spacing:	
Hardware:	
Other notes:	

**Superstructure:**

Surface dimensions: <i>(length &amp; width)</i>		Tread way: <i>(materials used)</i>	
Sections: <i>(used? - length?)</i>		Sect connections:	
# of boat wells:		Covered:	
Utilities: <i>(electric / water / sewer)</i>		Roofing material:	
# of enclosed floors:		# of rooms:	
Room usage & other notes:			

**OBSERVED EFFECTS***(see sketches on pg 8)***Observed Shore / Riparian Area Effects: *(Take Pictures)*****Observed Off-shore / Littoral Area Effects: *(Take Pictures)*****General Observations: : *(Take Pictures)***

Site No:

Page 5 of 8

**SITE SKETCHES & PICTURES**

Overall Site Sketch & Pictures:

A large empty rectangular box with a black border, intended for drawing site sketches and pictures. The box is currently blank.

Dock Detail Sketch & Pictures:

A large, empty rectangular box with a double-line border, intended for a detailed sketch and pictures of a dock. The box is currently blank.

Site No:

Page 7 of 8

Cross Section Site Sketch & Pictures:

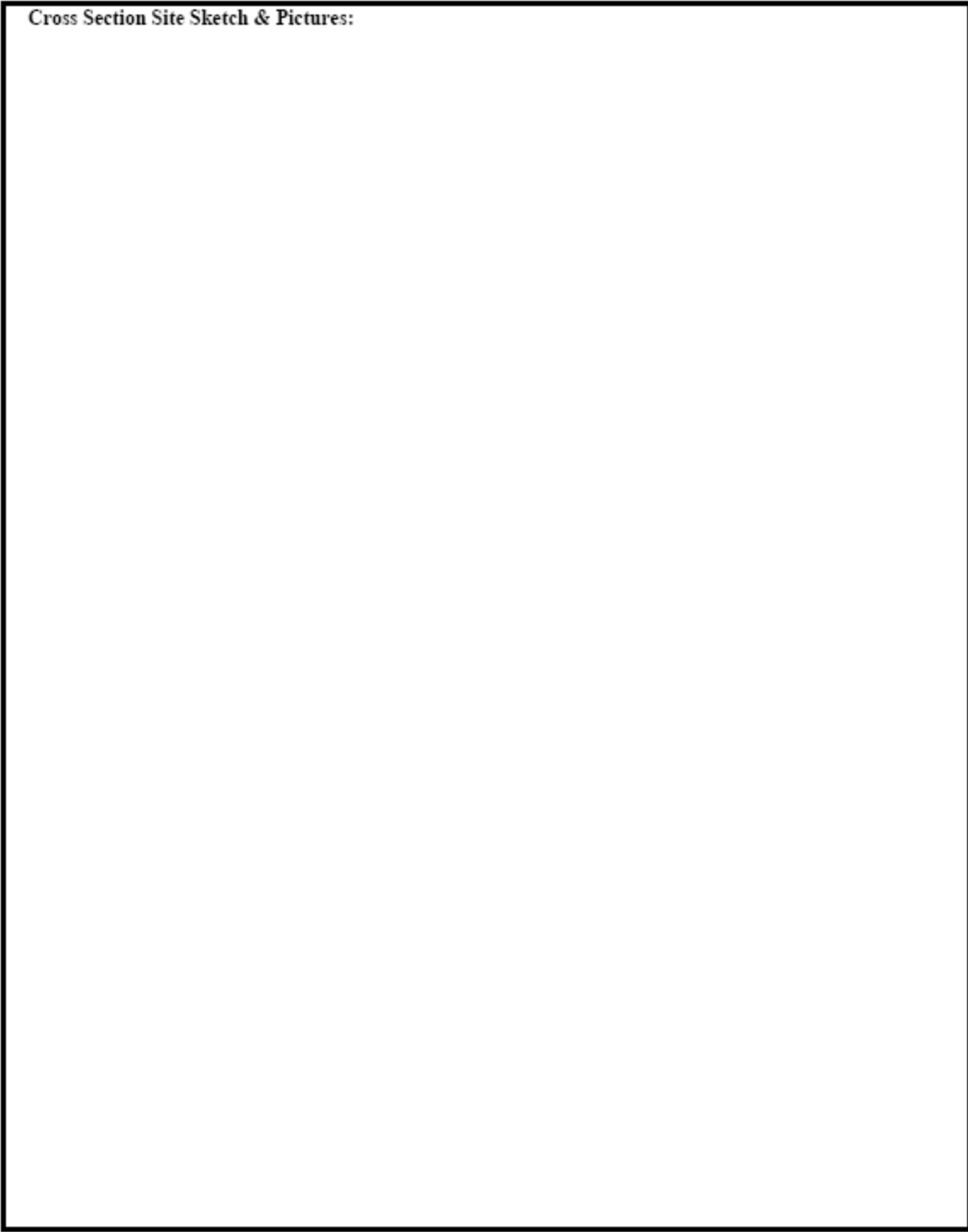

Dock Site Effects Sketches & Pictures:

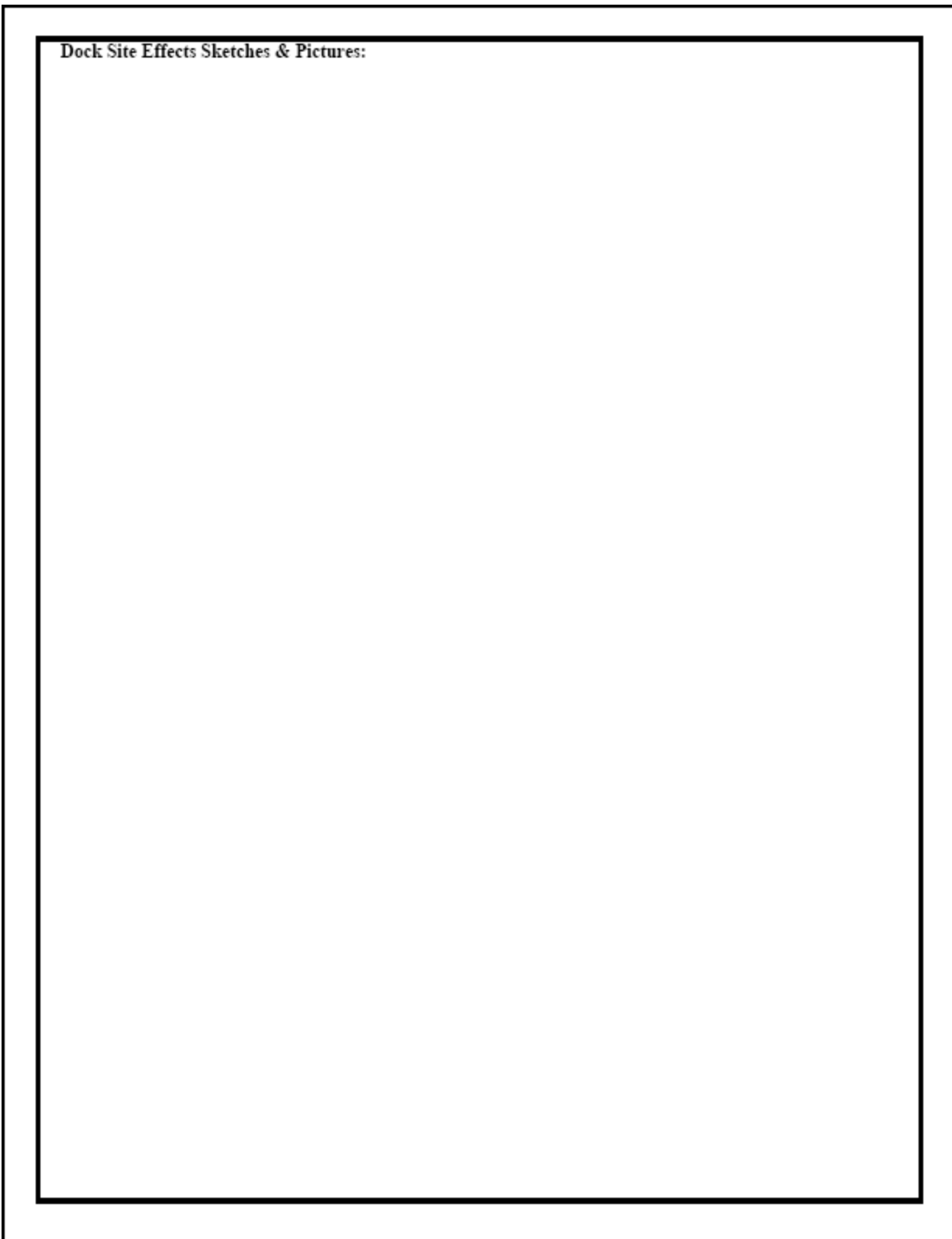



Appendix G - Calculation of Lake Bottom Area Consumed by a Crib vs the Surface Area  
Created by a Crib

### Calculation of Lake Bottom Area Consumed by a Sample Dock Crib vs the Surface Area Created

#### 1. Assumptions:

- Crib is 8' square.
- Logs are cylindrical 10' long x .5' in diameter.
- 1' of log extends beyond corner joint at each end.
- Ballast consists of washed spherical 10" or .8' rocks.
- Dock sits in 5' of water.
- Contact between round surfaces is zero; all calculations of created surface area are rounded down to the next lower whole number to correct for contact area error.

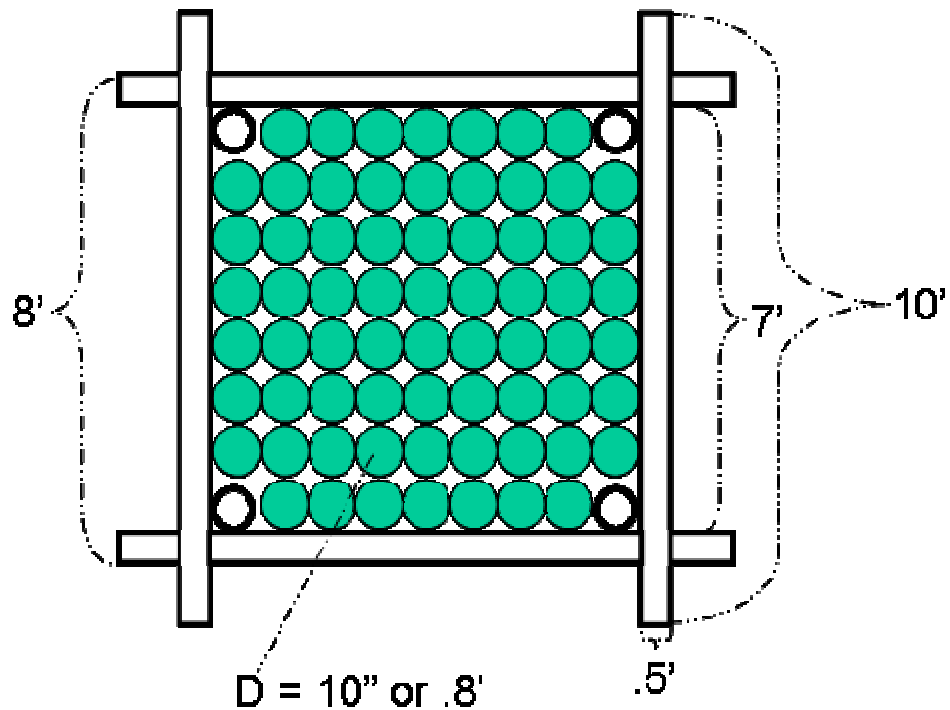
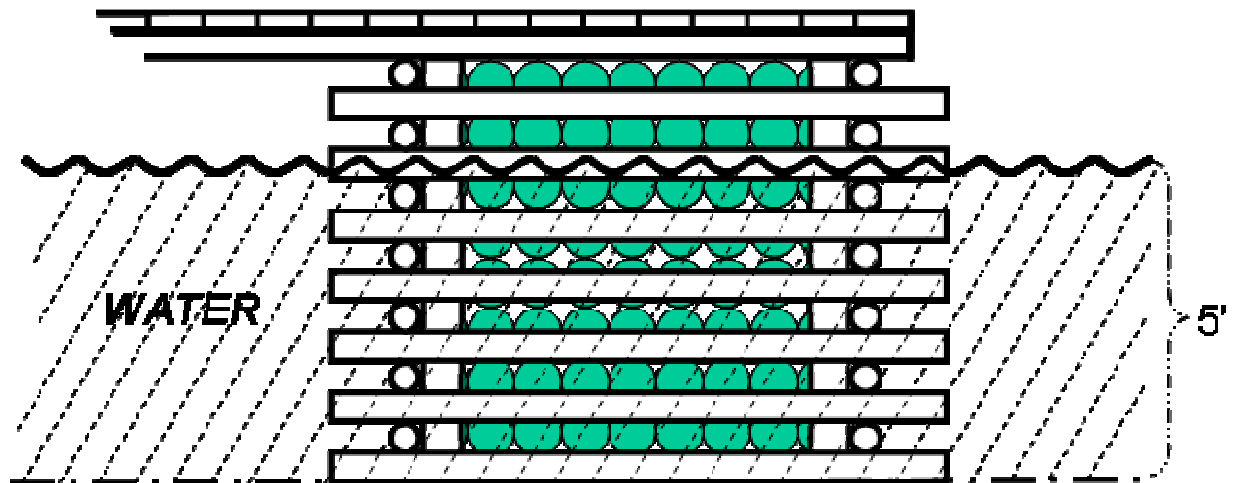

**2. Formulas used:**

- Area of a rectangle = length \* width.
- Area of a circle =  $\pi$  \* radius<sup>2</sup>
- Circumference of a circle =  $\pi$  \* diameter
- Area of a cylinder = [2 \* area of end circle] + [circumference of end \* length]
- Area of a sphere =  $4\pi$  \* radius<sup>2</sup>

**3. Lake bottom consumed by a timber crib:**

- Crib is 8'x 8' crib.
- Area covered by the crib proper = 8' \* 8' = 64 sq ft.
- Plus the area of the timbers ends beyond the corner joint = 1 \* .5 \* 4 logs = 2 ft<sup>2</sup>
- Total lake bottom = 64 + 2 = 66 ft<sup>2</sup>

**4. Surface area of the crib sides:**

- Sides are comprised of 10'x 6" cylindrical logs.
- 5 on a side in the water; 4 sides = 20 logs for sides.
- Surface area of one log is:
  - Ends =  $[(.25 \text{ ft})^2 * \pi] * 2 \text{ ends} = 0.4 \text{ ft}^2$
  - Sides =  $.5' * \pi * 10' = 15.7 \text{ ft}^2$
  - One log =  $.4 + 15.7 = 16.1 \text{ ft}^2 \approx 16 \text{ ft}^2$
- Surface area of the crib sides = 16 \* 20 = 320 ft<sup>2</sup>
- The lowest logs are sunk into substrate.
- Minus half of surface area of 4 logs =  $(16 \text{ ft}^2 * 4)/2 = 32 \text{ ft}^2$
- Total surface created by sides = 320 - 32 = 288 ft<sup>2</sup>

**5. Surface area of the crib corner posts:**

- 4 corner posts are comprised of 8'x 6" cylindrical logs.
- 5' of each post is in the water.
- Surface area of one log is:
  - End =  $(.25 \text{ ft})^2 * \pi = 0.2 \text{ ft}^2$
  - Height =  $.5' * \pi * 5' = 7.9 \text{ ft}^2$
  - One log =  $.2 + 7.9 = 8.1 \text{ ft}^2 \approx 8 \text{ ft}^2$
- Surface area of the crib corner posts = 4 \* 8 = 32 ft<sup>2</sup>

**6. Surface area of the crib floor:**

- Crib floor space is 7' square.
- Floor is comprised of 10 half logs:
- Surface of one floor log = half area of the cylinder + area of the cut face rectangle
  - Ends =  $[(.25 \text{ ft})^2 * \pi]/2 * 2 \text{ ends} = 0.2 \text{ ft}^2$
  - Sides =  $.5' * \pi * 7' = 10.9 \text{ ft}^2$
  - One log =  $.2 + 10.9 = 11 \text{ ft}^2$
- Total surface of the 10 floor logs = 10 \* 11 = 110 ft<sup>2</sup>

**7. Surface area of the crib ballast:**

- Volume of open space in the water =  $7' * 7' * 5' = 245 \text{ ft}^3$
- Ballast consists of .8' spherical rocks.
- Ballast area:
  - Will hold 8 rocks across and 6 rocks high =  $8 * 8 * 6 = 384$  rocks
  - Less ballast area consumed by corner posts =  $6 \text{ rocks} * 4 \text{ corners} = 24$  rocks
  - Total =  $384 - 24 = 360$  rocks
- Each rock's surface area =  $4 * \pi * (.4)^2 = 2.01 \text{ ft}^2$
- Total surface area of the ballast =  $360 * 2 = 720 \text{ ft}^2$

**8. Total surface area created by the crib:**

- Total surface created by sides =  $288 \text{ ft}^2$
- Total surface created by corner posts =  $32 \text{ ft}^2$
- Total surface of the 10 floor logs =  $110 \text{ ft}^2$
- Total surface area of the ballast =  $720 \text{ ft}^2$
- Total surface area of the crib =  $288 + 32 + 110 + 720 = 1150 \text{ ft}^2$

**8. Analysis Totals:**

- Total lake bottom consumed by the sample crib dock =  $66 \text{ ft}^2$
- Total benthic surface created by the sample crib dock =  $1150 \text{ ft}^2$

Appendix H – Dock Siting Detail Graphics

## Dock 1 Cadogan Point, Dudley Bay

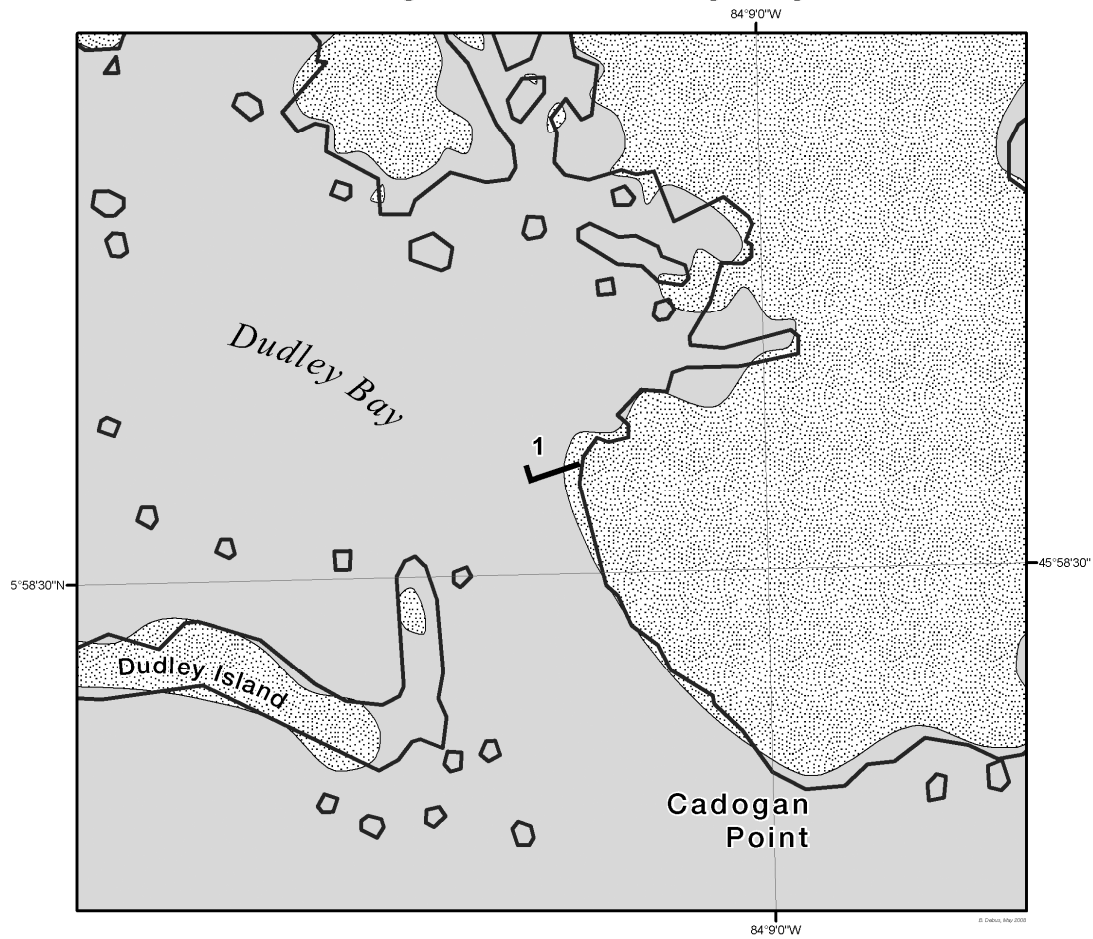

- Docks
- Extent of 2005 Aerial Photograph
- Water

- Water Lines:**
- Mean High
  - Mean Lower Low

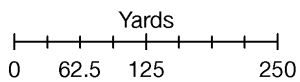
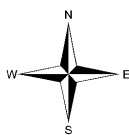

## Docks 2, 3, 4 Marquette Island, Fulyard Point

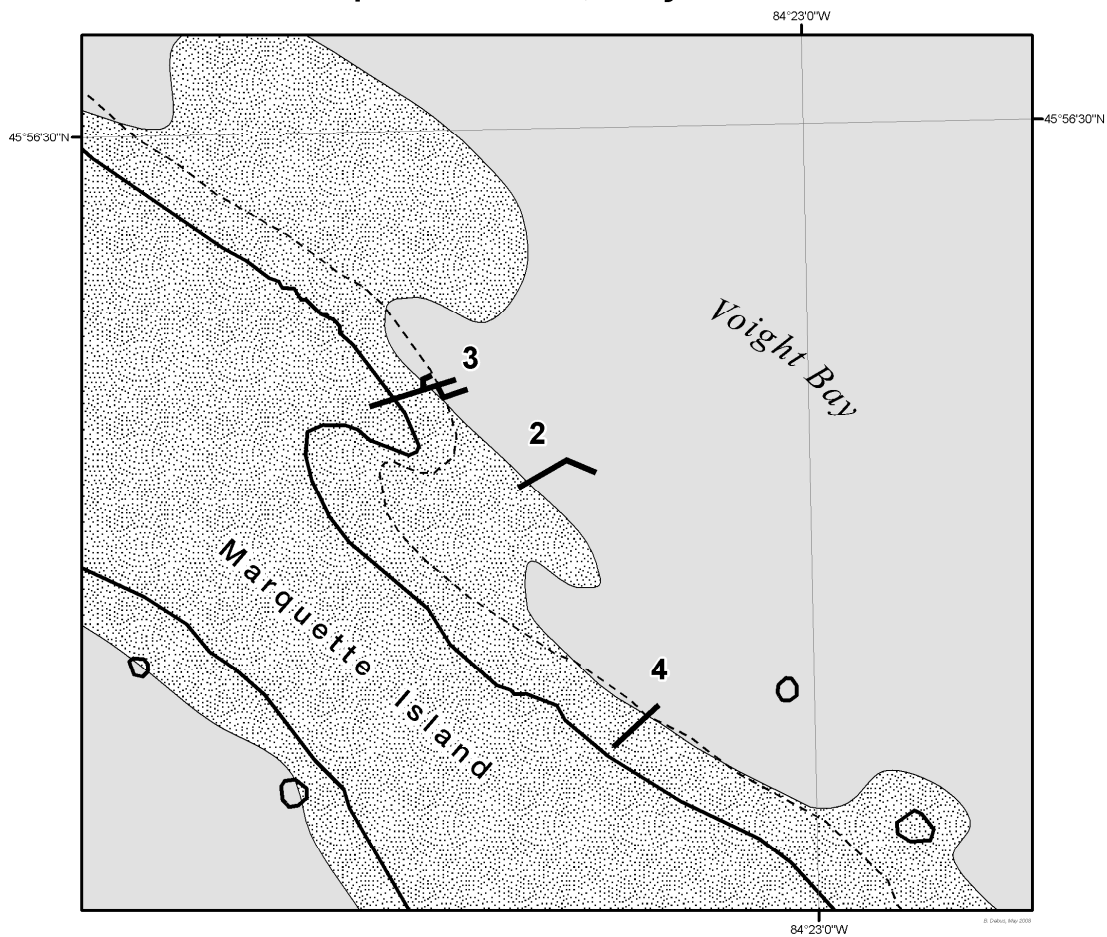

- Docks
- Extent of 2005 Aerial Photograph
- Water

- Water Lines:**
- Mean High
  - Mean Lower Low

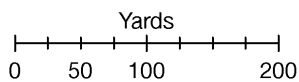
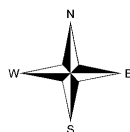

## Docks 5, 6, 7, 8 Cedarville, Cedarville Bay

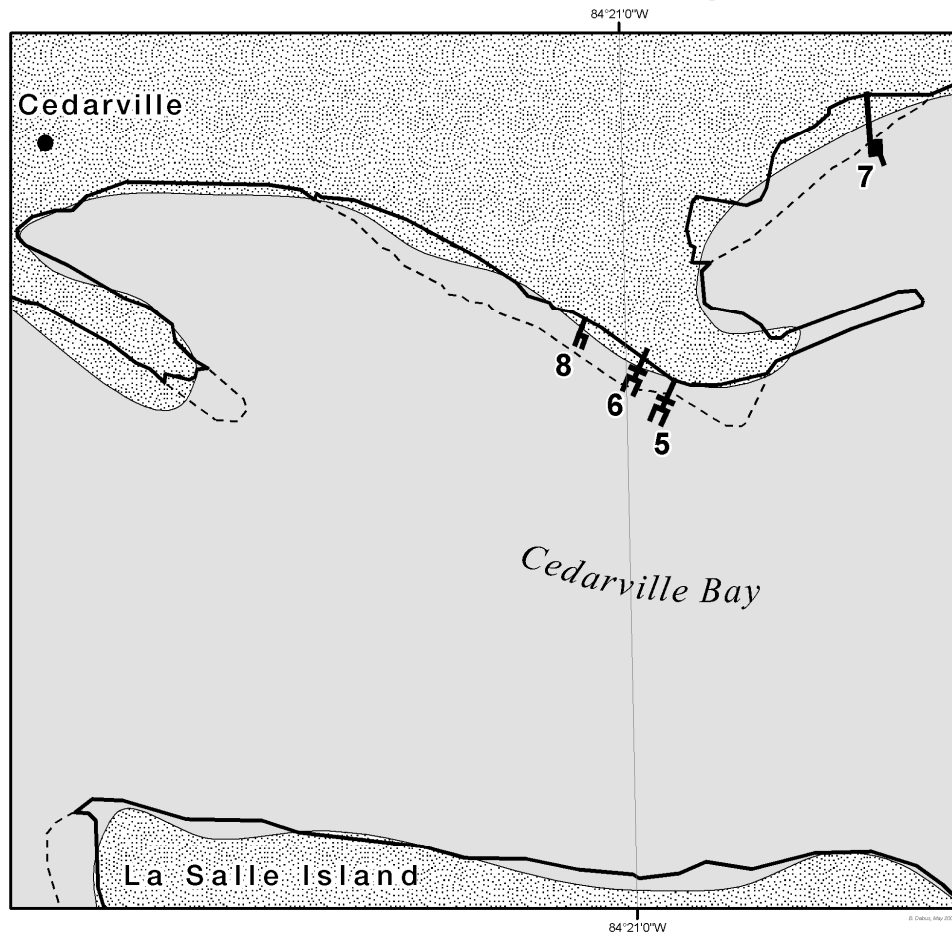

- Docks
- Extent of 2005 Aerial Photograph
- Water

- Water Lines:**
- Mean High
  - Mean Lower Low

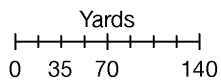
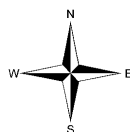



## Docks 9 and 10 Drummond Island Harbor, Potagannissing Bay

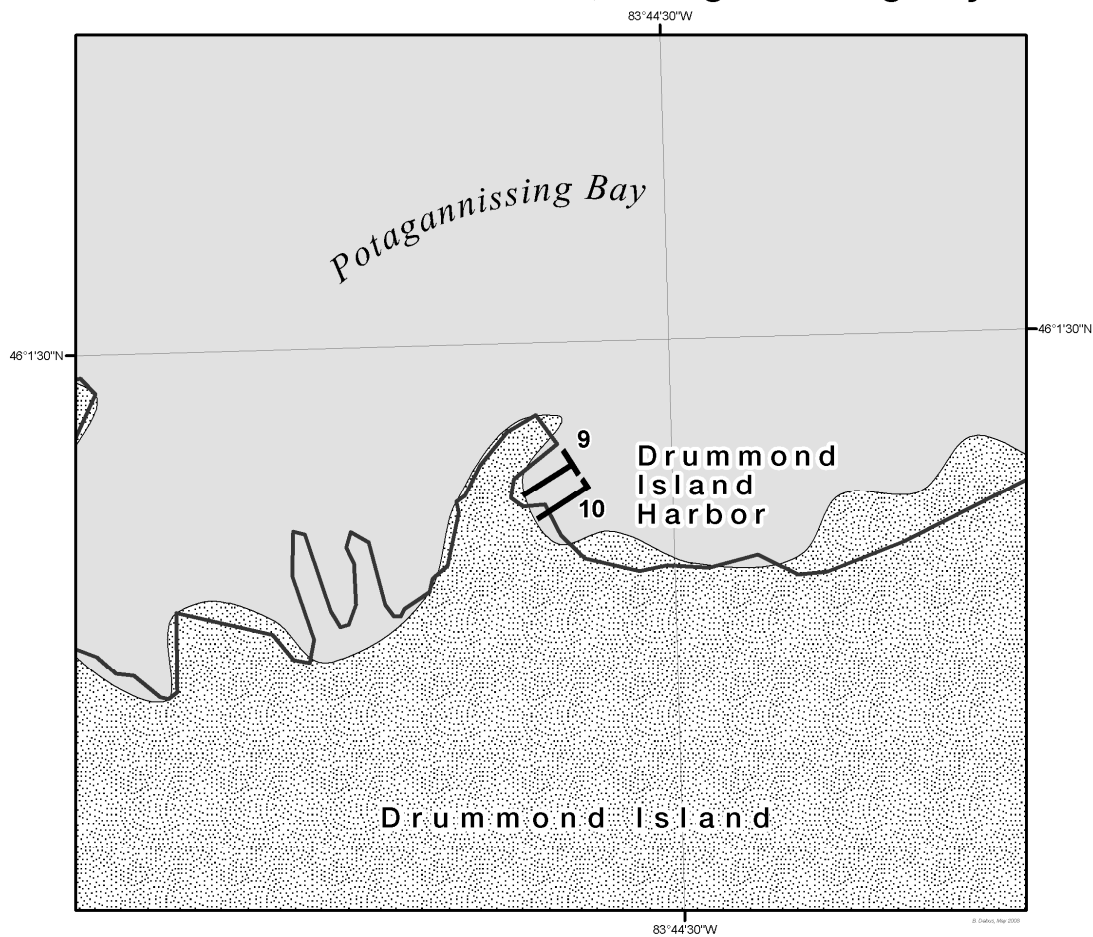

- Docks
- Extent of 2005 Aerial Photograph
- Water



**Water Lines:**

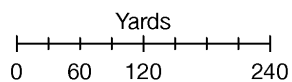
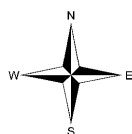

- Mean High
- Mean Lower Low

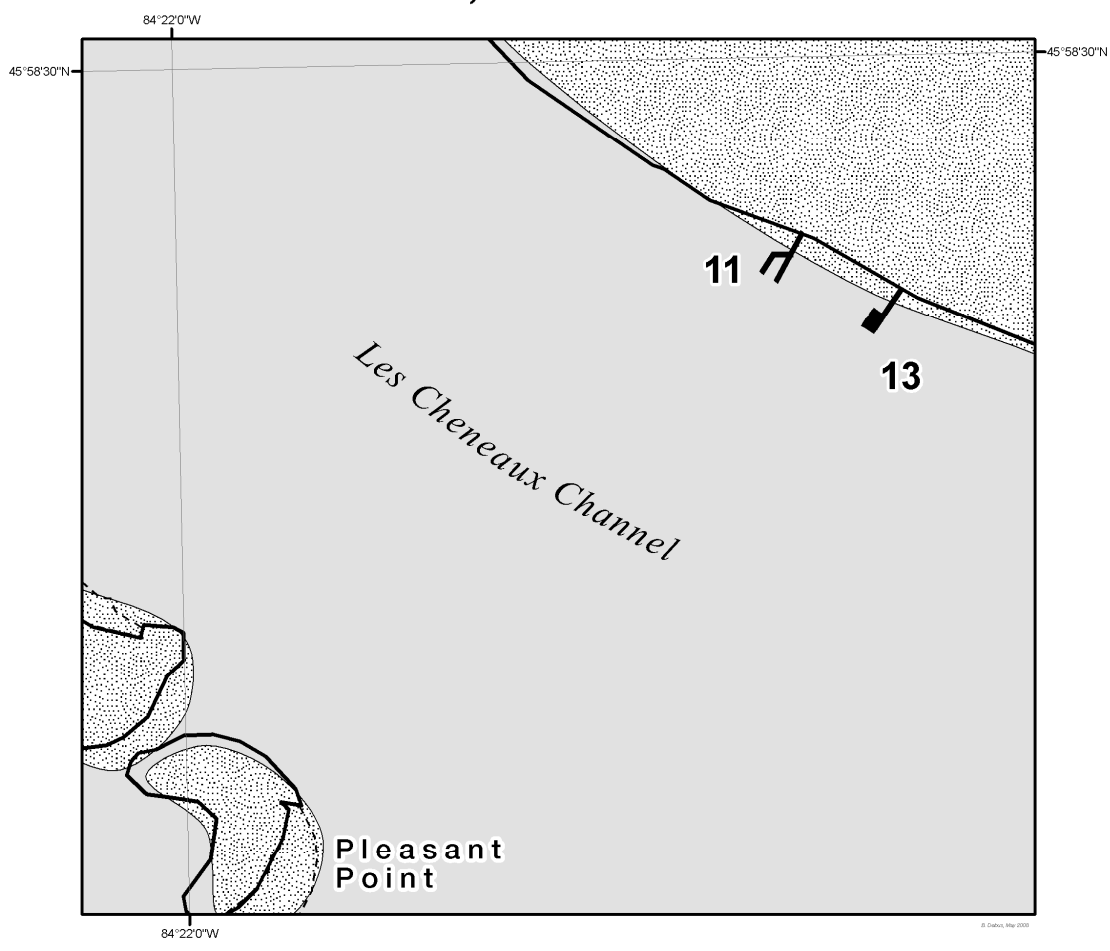

### Docks 11 and 13 Conner Point, Les Ceneaux Channel





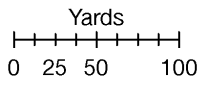

-  Docks
-  Extent of 2005 Aerial Photograph
-  Water

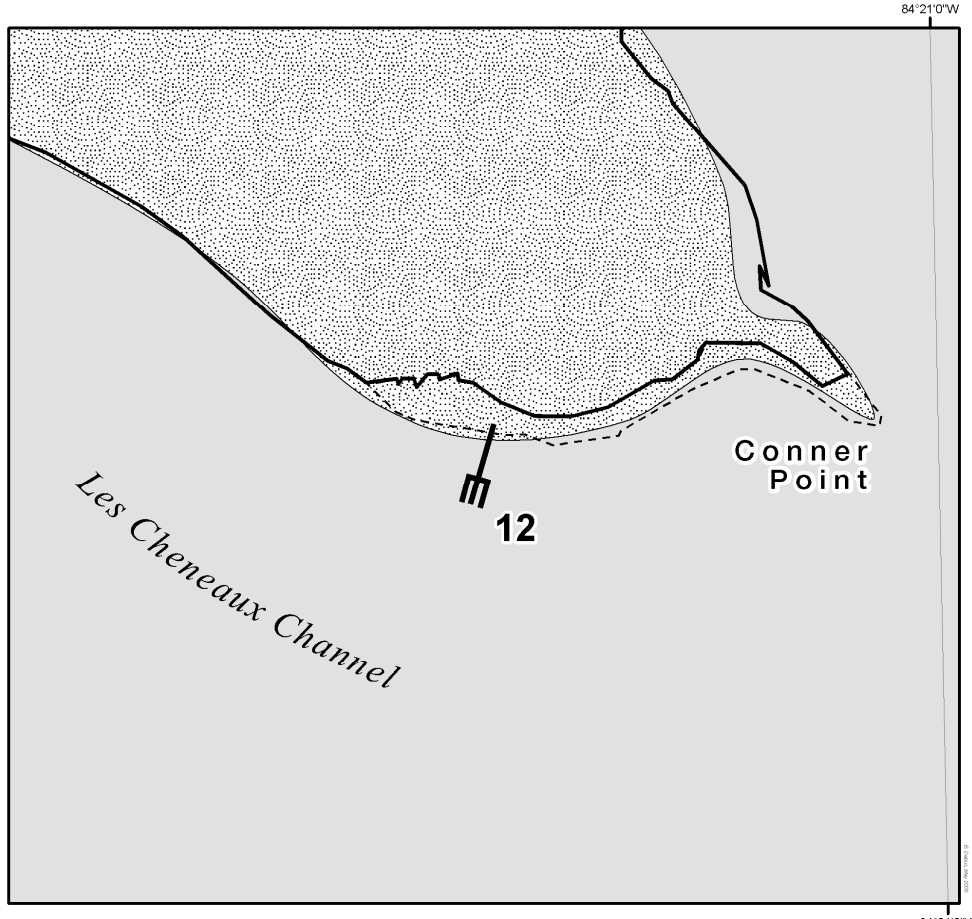

- Water Lines:**
-  Mean High
  -  Mean Lower Low



# Dock 12 Conner Point, Les Ceneaux Channel



-  Docks
-  Extent of 2005 Aerial Photograph
-  Water

- Water Lines:**
-  Mean High
  -  Mean Lower Low

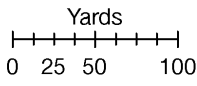
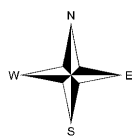

## Docks 14 and 15 Fishery Point, East Entrance

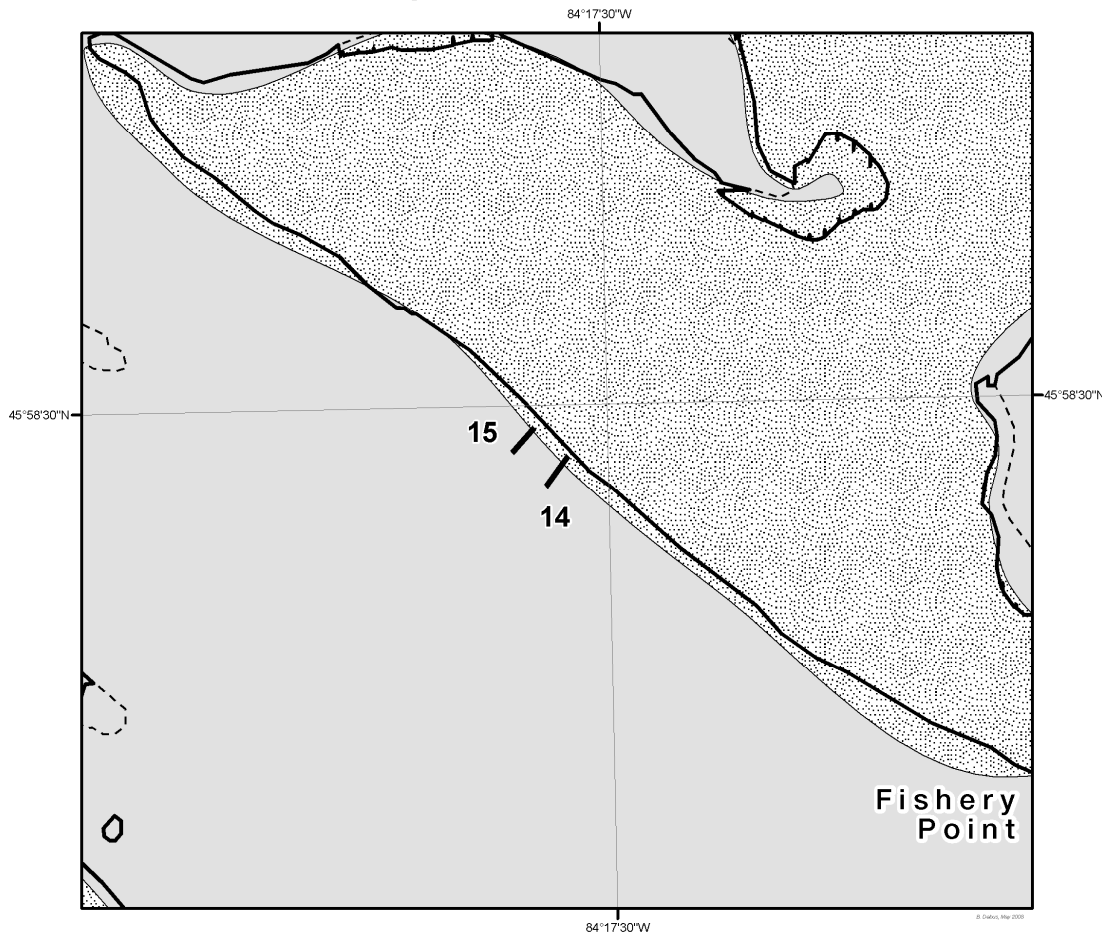

- Docks
- Extent of 2005 Aerial Photograph
- Water

- Water Lines:**
- Mean High
  - Mean Lower Low

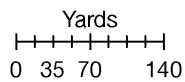
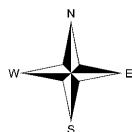

## Dock 16 Fishery Point, McKay Bay

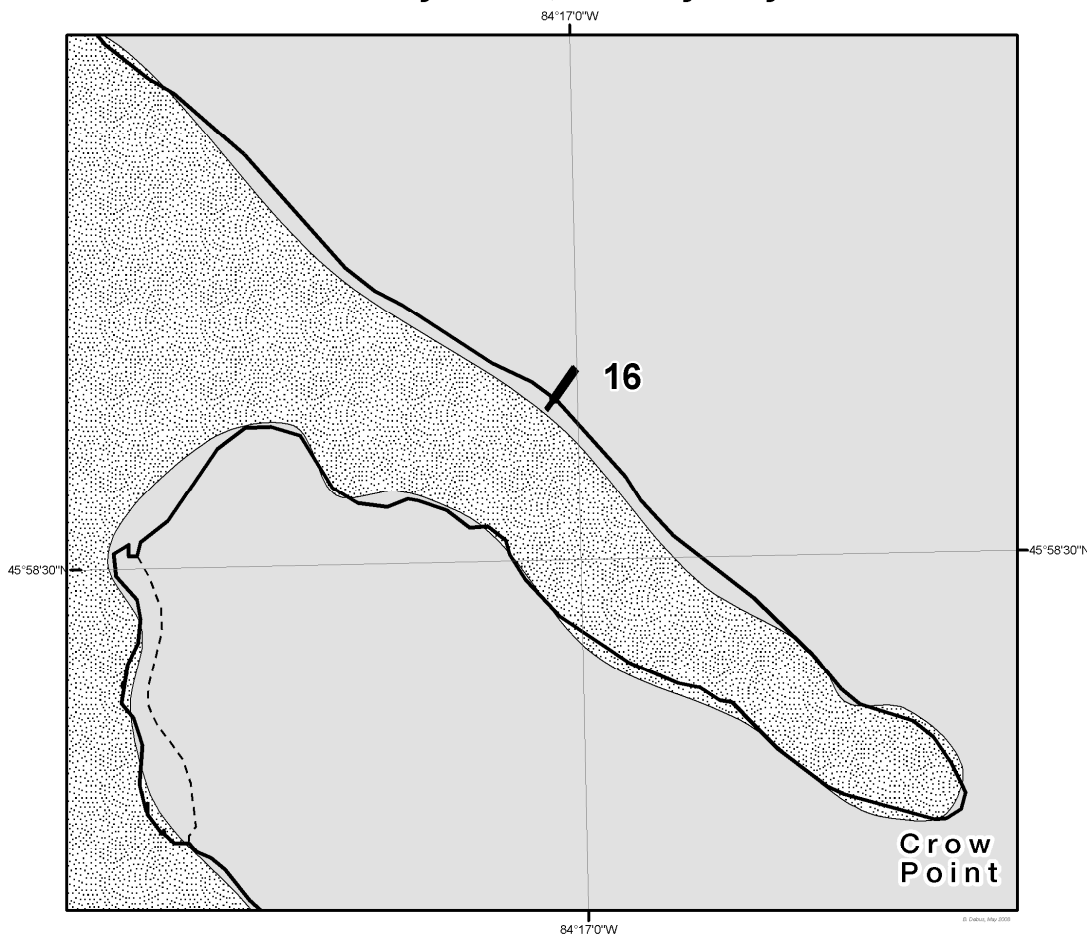

- Docks
- Extent of 2005 Aerial Photograph
- Water

- Water Lines:**
- Mean High
  - Mean Lower Low

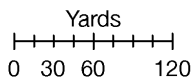
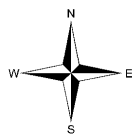

## Dock 17 Hill Island, Hill Channel

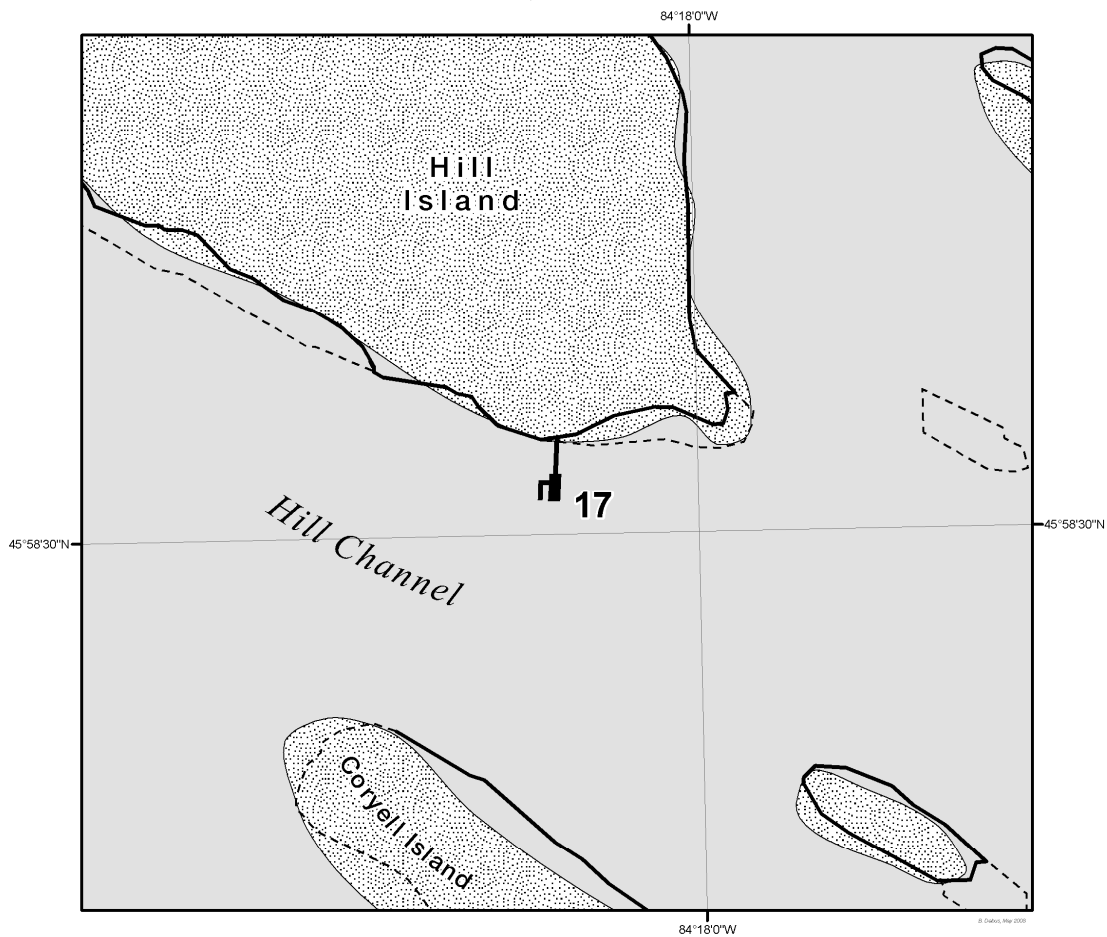



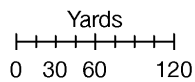
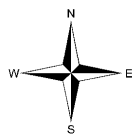

- Docks
- Extent of 2005 Aerial Photograph
- Water

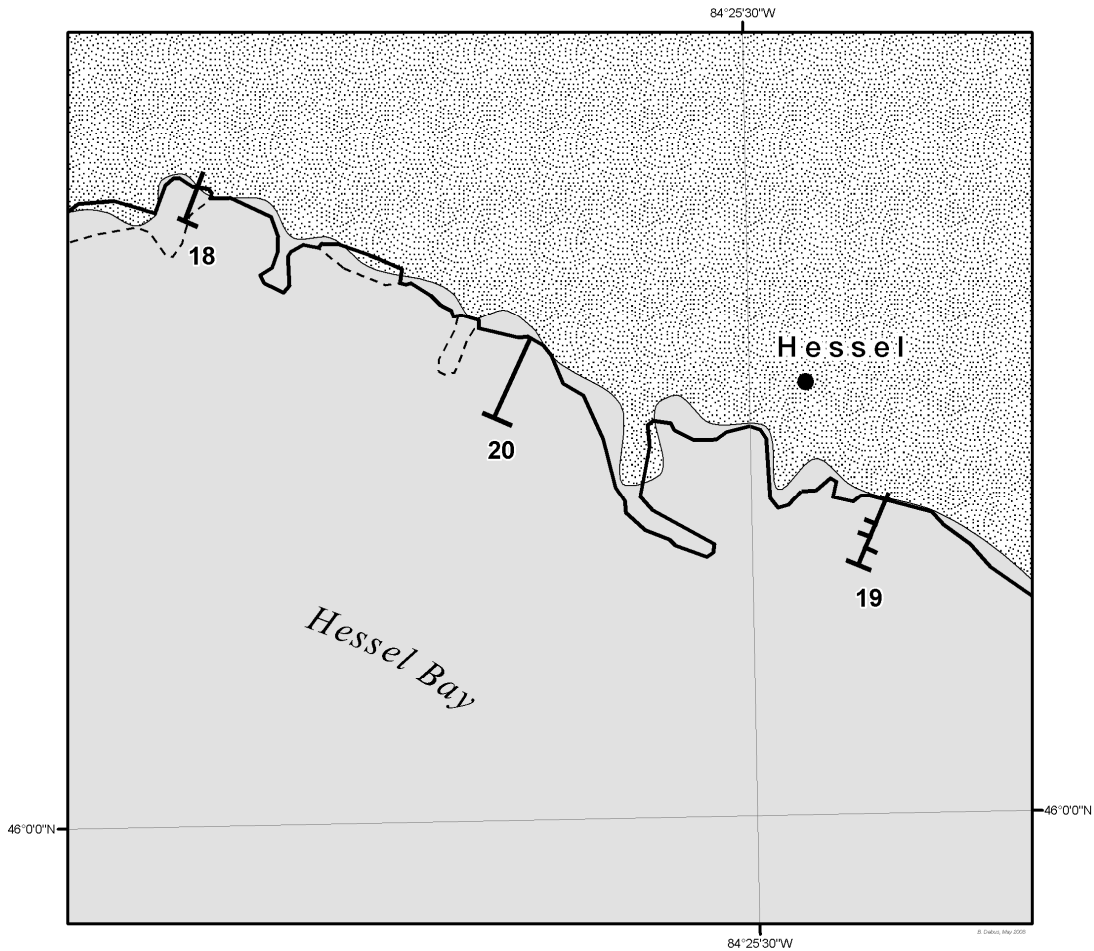

- Water Lines:**
- Mean High
  - Mean Lower Low



# Docks 18, 19, 20 Hessel Bay, Hessel Harbor



-  Docks
-  Extent of 2005 Aerial Photograph
-  Water

- Water Lines:**
-  Mean High
  -  Mean Lower Low

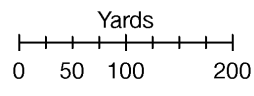
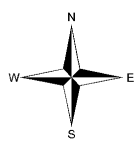

Appendix I – Recommended Michigan Crib Dock Permit & Construction Standards



*Recommended*  
**State of Michigan**  
**Crib Dock Permit & Construction Standards**

Crib dock construction permits will be approved, and subsequent construction monitored, so as to assure they achieve necessary service requirements, minimize the proposed dock's environmental and waterway safety impact, and assure public safety and welfare. The following standards will establish a baseline to assure meeting those goals.

- **Crib dimensions:**
  - No cribs will be larger than 16 feet square.
  - Cribs will be designed and constructed so that the top crib member is not higher from the lake bottom than either of the base dimensions, length or width.
- **Crib ballast:**
  - Crib ballast will consist of washed 6-12 inch natural stone, crushed or river washed.
  - Ballast stone must be inspected and certified contaminant free.
  - Recycled natural aggregate may be used if it is washed and contaminant free.
- **Crib spacing:**
  - Cribs will be set to allow at least 50% unobstructed littoral flow space by placing cribs at least 11 feet apart.
  - Cribs in parallel dock sections will be arranged in symmetrical manner to prevent the cribs in one section from blocking the flow space of a parallel section.
  - At the 10 year Ordinary High Water Mark (OHWL), the first on-shore cribs will be set 5 feet above the OHWL; the off-shore cribs will be at least 10 feet below the OHWL.
- **Michigan Residential Code Requirements:** Selected applicable Michigan residential code standards will be complied with to include, but not limited to the standards for outdoor electric service outlets and lighting.
- **USACE Safety Requirements:** All docks will be constructed so as to comply with established USACE Shoreline Management dock safety requirements to include but not limited to:
  - Docks will be clearly marked with 3 inch diameter amber or red reflectors at 60 inch intervals, beginning no more than 6 inches from the lakeward corners running to the OHWL.
  - In high traffic areas, docks may be required to install electric safety lighting, powered by either land-based or solar cell battery service.
  - All walkway surfaces will be constructed with ACQ treated or other water resistant lumber, such as Cedar.
  - All walkways shall be at least 4 feet wide; all dock areas at least 8 feet wide.
  - All walkways more than 48" above the ground or water will have handrails 36-48 inches above the walkway surface; handrails are not required in areas intended for regular boat moorage.
  - Stairways with 3 or more steps will have handrails at 36-48 inches above the step tread.
  - All walkway surfaces will be constructed and maintained so as to minimize trip hazards; including but not limited to setting nail and screw heads, repairing loose or uneven decking and carpeting, cleaning grease and oil spots, etc.

