

2017

## Developing an Electronically Controlled External Cavity Diode Laser System for use in Atomic Spectroscopy

Samuel C. Carano  
scarano@emich.edu

Follow this and additional works at: <https://commons.emich.edu/mcnair>

---

### Recommended Citation

Carano, Samuel C. (2017) "Developing an Electronically Controlled External Cavity Diode Laser System for use in Atomic Spectroscopy," *McNair Scholars Research Journal*: Vol. 10 , Article 4.  
Available at: <https://commons.emich.edu/mcnair/vol10/iss1/4>

This Article is brought to you for free and open access by the McNair Scholars Program at DigitalCommons@EMU. It has been accepted for inclusion in McNair Scholars Research Journal by an authorized editor of DigitalCommons@EMU. For more information, please contact [lib-ir@emich.edu](mailto:lib-ir@emich.edu).

# DEVELOPING AN ELECTRONICALLY CONTROLLED EXTERNAL CAVITY DIODE LASER SYSTEM FOR USE IN ATOMIC SPECTROSCOPY

*Samuel C. Carano, Primary Author*

*David M. Yudowin, Collaborator*

*Dr. Éric Paradis, Mentor*

## ABSTRACT

The purpose of this research project is to implement and test an electronic control system for an external cavity diode laser (ECDL). ECDLs can be used in atomic and molecular spectroscopy to provide a precise frequency probe of the atomic level structure. [1] More specifically, our ECDL will allow us to excite the valence electron of rubidium atoms. Rubidium is desired because it is an alkali grouped element [2], can be contained easily in a vapor cell [3], and has an excitation wavelength close to that of standardized diode lasers. [4] In order to obtain successful results, a strong focus on the theory, design process, and testing procedures must be incorporated into this project. Current progress shows stable results in controlling internal EDCL temperature and in producing laser output feedback.

## INTRODUCTION

### Diode Lasers

To understand the potential application this research will pose, it is necessary to describe the basic theory of semi-conductive material, electron-hole recombination, semiconductor doping, and how these characteristics work to allow diode lasers to function optimally.

A semiconductor is a material in which its conductive property exists dynamically between that of a conductor and an insulator. [5] A semiconductor's conductivity can be altered by changing the internal temperature of the material or by adding impurities to the material's physical combination. Semiconductors can be handled a little differently when compared to atoms of other types of elements or compounds. [4,6]

Rather than treating the atoms within a semiconductor as individual components, it is more appropriate to approximate discrete energy bands that the valence electrons among all of the atoms can traverse. In this sense, the collective group of atoms in the semiconductor contains a lower level valence band in which some valence electrons exist in a ground state, and an upper level conductive band in which other valence electrons exist in an excited state. The conductive band and valence band are separated by a forbidden energy gap that is dependent on the material used as a semiconductor. The forbidden energy gap represents the amount of energy it takes for an electron to jump from the top of the valence band to the bottom of the conductive band. [6,4]

The temperature of the semiconductor material is also necessary to consider, as it is proportional to the number of electrons that can occupy the conduction band. When an electron leaves the valence band through thermal excitation, the space it leaves behind is referred to as an *electron hole*. In contrast, when a decayed electron returns to the valence band and fills an unoccupied state, the process is referred to as *electron-hole recombination*. The idea is to design a semiconductor that encourages this process to occur more frequently. [6]

Doping encourages this by adding impurities to the semiconductor's physical combination. This in turn increases the potential for electron-hole combination to take place. Pure semiconducting material used for diodes, such as silicon, germanium, or gallium compounds, are referred to as *intrinsic*. A semiconductor is referred to as *extrinsic* after the doping process combines electron donor, n-type material, or electron acceptor, p-type material into the semiconductor. Combining an n-type semiconductor and p-type semiconductor creates a diode that can be used as a laser. [6]

The diode laser is based on the concept of gain media, where optical gain is achieved by *stimulated emission*. [7,8] The stimulated emission is achieved when an electrical current is applied to the p-n junction of the diode. The energy from the current that is pumped into the semiconductor material is slightly above the energy required to cause electrons to jump from the valence band into the conductive band and then decay back into the valence band. This process repeats continually as long as current is applied. [8]

When an electron returns to the valence band, it can release the energy in one of two ways: It can radiate the energy, or it can transfer the excess energy into the semiconductor lattice, crystal-like structure. When the electron radiates energy, we can interpret this as light. [7]

The aim of describing the previous characteristics is to provide a very basic understanding of how a semiconductor laser functions. A more in-depth description of the probabilistic nature of each electron's behavior, however interesting it may be, surpasses the scope of this paper.

## **Rubidium**

Concerning spectroscopy, consideration for determining which element is most fitting depends on which properties of the element can be exploited, and what constraints or design considerations might be inherent to the research. In our case, a more economical approach was evident, and thus rubidium was desired for several reasons. Rubidium is an element of the alkali metal group that exists naturally in two primary stable isotopes,  $^{85}\text{Rb}$  and  $^{87}\text{Rb}$ , the difference corresponding to additional neutrons in each cell's nucleus. The ratio that occurs naturally is around 72% of  $^{85}\text{Rb}$ , and 28% of  $^{87}\text{Rb}$ . For our research, our sample will be contained in a glass vapor cell. [2] The hyperfine level structure of rubidium is described by differences in the central potential, electric monopole of each atom, caused by higher order multipole moments. Rubidium is desired in this sense because in its ground state it only contains one electron in the outer most occupied energy level. As such, each rubidium atom can be approximated as an infinitely large point mass along with one electron. [9]

The wavelength required to cause an electron to jump from ground state to excited state for both isotopes is around 780 nm [10,11], where the bottom grouping of states represents the ground state, and the upper grouping represents the excited state. This wavelength is also desired because the standard mass-produced diode lasers are already manufactured to perform at this wavelength.

### **Diode Laser Applications**

While it may be difficult to picture using a diode laser in a typical scenario, there are a few niche branches of experimental physics, as well as some industrial technologies that use them quite frequently.

#### ***Atom trapping and laser cooling***

When the correct excitation frequency, depending on the atom used, in the diode laser is obtained, the light causes the outermost electron to jump into a higher, unoccupied, energy level. In other words, some of the light is absorbed and converted into internal energy of the atom. The angular momentum of the light also changes the angular momentum of the electron. This exchange creates a velocity dependent, non-conservative force which can be used to cool the atom. [5]

After the light has been absorbed, the electron will remain in excited state for a probabilistic amount of time. Depending on the light intensity, it will return to ground state, either by stimulated emission or spontaneous emission, and release the extra energy in the form of a photon. If the light intensity is low enough, the electron will be more likely to return through spontaneous emission. While there is no direct heat exchange in this process, temperature change does correspond to the energy of the light scattered. [5]

The purpose of cooling atoms relates to the kinetic energy of the atom. When an atom cools, the kinetic energy decreases, and if the atom cools enough, the atom has almost no kinetic energy. This is significant because it allows for very precise spectroscopic measurements. Some of the most precise measurements of the gravitational constant, or for atomic clocks, are accomplished by cooling the atoms with this process. [12]

### ***Electromagnetic induced transparency***

Many commercial applications that require electric field sensing require precision that is limited by the disruptions caused by the metal transmission lines and antennas imposed by conventional means of measurement. [13] A potential solution for making more accurate measurements makes use of highly excited atoms contained in a vapor cell. The measurement of the electric field is recorded in the presence of the ECDL probe, as well as a coupling beam. When the electric field is not present, a narrow transmission peak is observed where the ECDL probe would normally be absorbed. When the electric field is applied, a narrow dip in the absorption line occurs. The absorption signal is sensitive to the electric field applied, and these differences are associated with different excitation pathways. This process is known as Electromagnetic Induced Transparency. [13]

## **DESIGN AND METHODOLOGY**

### **Littrow Configurations**

The Littrow configured diode laser pertains to the orientation of physical components such as the collimator lens,

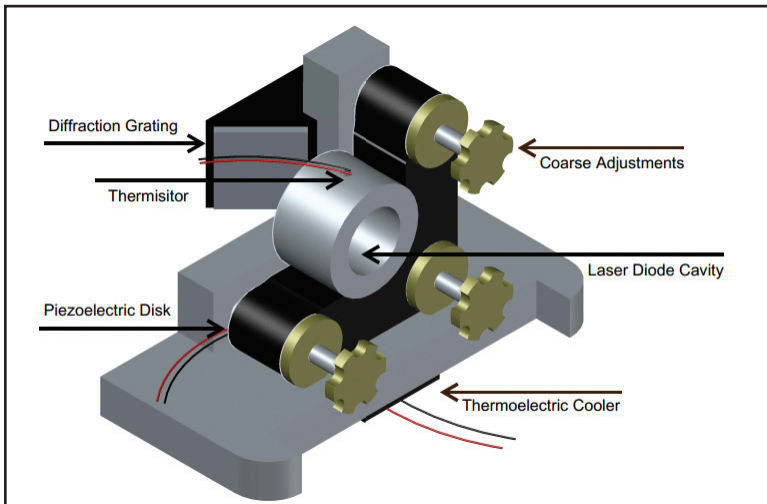

**Figure 1:** ECDL Mount and Electronic Feedback Devices

diffraction grating, piezoelectric disks, and various mounts. [14,1] The purpose of this configuration is to provide the diode laser with an external cavity (ECDL). This external cavity creates an optical feedback loop in which a small amount of the laser output, in this case the 1<sup>st</sup> order diffraction, is reflected back into the laser diode. [15] This provides laser output stability of less than 1 MHz bandwidth, and the potential for laser tuning. [4] More specifically, the optical feedback generated by the Littrow configuration provides the ability to provide slight adjustments to the wavelength of the diode laser's output to match the desired set point associated with the excitation wavelength of rubidium, 780 nm (**Figure 1**)

### ***Collimator lens***

After the light beam leaves the semiconductor laser located in the laser diode cavity, it is highly divergent. The laser has to be collimated in order to create a more uniform beam. [16] The distance between the lens and the laser diode is determined by the focal length of the lens that will be used.

### ***Diffraction grating***

A diffraction grating allows incoming light to be split into different wavelengths. The correct diffraction grating for the Littrow configuration is chosen by using the following equation [4]:

$$2 \times A \times \sin\theta = n\lambda$$

$A$  is the distance between lines (mm) on the diffraction grating,  $n$  is the order of the reflection,  $\theta$  is the angle between the normal of the diffraction grating and the incident beam, and  $\lambda$  is the wavelength of the laser output. The angle needs to be close to 45° so that the 0<sup>th</sup> order diffraction will reflect directly off of the diffraction grating at a convenient angle of 90°. In our case, we needed to choose the correct grating to work with 780 nm at the desired angle of incident. [12,17]

$$\frac{1}{A} = \frac{2 \times \sin 45^\circ}{780 \times 10^{-6}} \text{ mm}^{-1} = 1813.09 \frac{\text{lines}}{\text{mm}} \approx 1800 \frac{\text{lines}}{\text{mm}}$$

### **Piezoelectric Disk**

A piezoelectric disk is an electric transducer that provides very precise physical adjustments via applied voltage. It is used

to provide feedback for our ECDL by adjusting the angle of the diffraction grating through the use of electronic feedback and a PID controller. While coarse adjustments can be accomplished through physical means, a closed loop electronic control system is much faster and more efficient over long periods of time.

### ***Electronic Control System***

Many different types of systems that operate in a wide variety of industrial and domestic applications benefit from the use of electronic feedback. Electronic feedback is an element of closed loop control systems used to enable a system process, actuation, to automatically account for disturbances and maintain operation tolerance. It is necessary to understand what system actuation needs to be monitored, how feedback should be implemented into the system loop, and what type of response is required for operation. [18]

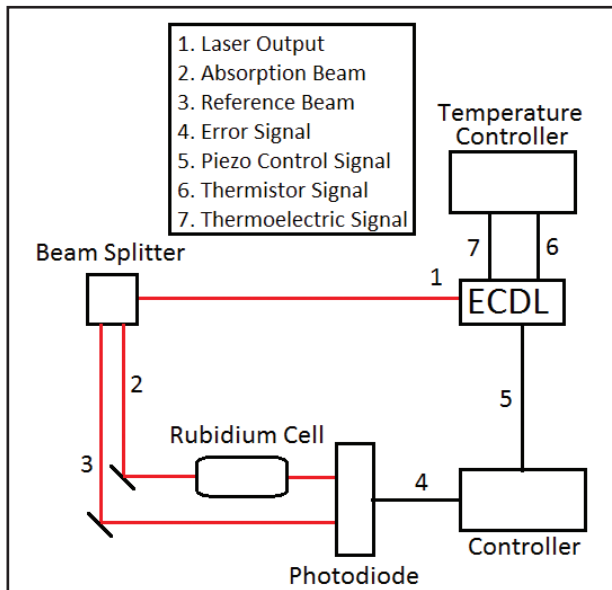

**Figure 2:** Layout of Electrical Components and Signal Paths

Any form of actuation, be it hydraulic, mechanical, electrical, or pneumatic, can be implemented into a closed loop controlled system. A control system can perform a desired operation and remain within a specific window of performance



with little to no user input. For this research project we are concerned with two forms of actuation control: the mechanical movement of the diffraction grating angle that provides optical feedback, and the internal temperature of the ECDL (**Figure 2**).

### **Optical Feedback**

A photodiode amplification circuit is required to implement optical feedback in the ECDL. When the beam leaves the ECDL, it is directed towards an optical beam splitter and is split into two separate beams. One of the beams is used as a reference point, while the other beam is directed into the rubidium vapor cell. As the frequency of the output beam of the ECDL differs, so does the absorption level within the rubidium cell. The differences in absorption levels are detected by comparing the output of the rubidium vapor cell to the reference beam, using two photodiodes connected to an amplification circuit. [4]

Photodiodes act as transducers by turning light intensity into voltage signals. In the circuit used to provide feedback, one signal is generated from each photodiode. Each signal is amplified using an inverting op-amp, and then summed into a summing op-amp to produce an output signal representative of the absorption spectrum of rubidium. There is adjustable gain for the op-amps as well as a DC offset in order to adjust the output correctly. It is also important to isolate the photodiodes from ambient light, as it will interfere with the operation. [18]

### **Temperature Feedback**

When dealing with semiconductor devices, temperature fluctuation can drastically change operating parameters. Temperature is also very susceptible to disturbance from the surrounding laboratory environment over longer periods of time. The process of implementing feedback in order to regulate temperature control uses a thermistor and a thermoelectric cooler to account for disturbances and provide feedback. [1]

A thermistor is a passive transducer that changes its resistance, based on the surrounding temperature that it senses. The thermoelectric cooler is a flat square device that uses a supplied

voltage to produce heat on either side, depending on how the flow of current is directed through the device. The thermistor provides feedback and the thermoelectric cooler provides actuation. The thermistor and thermoelectric cooler need to be located in direct contact with the ECDL mount to provide effective feedback. [14,1]

### **PID Controller**

A controller treats the measured feedback as an error signal which it uses to correct system operation within a given

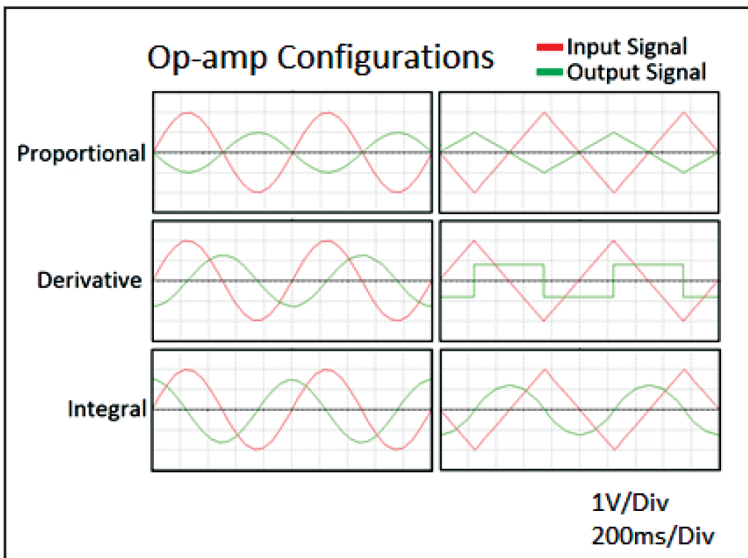

**Figure 3:** Sine and Triangular Wave Response in Op-Amp Configurations

tolerance of a predetermined set point. The controller determines how far current operation is from the set point and creates a signal to adjust the actuation process accordingly. In order to control both optical and temperature feedback, a PID controller is used.

PID stands for proportional, integral, and derivative because each controller design uses an assembly of these three types of op-amp configurations. Each op-amp takes the error signal provided by the associated feedback device and performs a mathematical operation to form a new output. **Figure 3** shows how these operations work on sine waves and triangular waves.

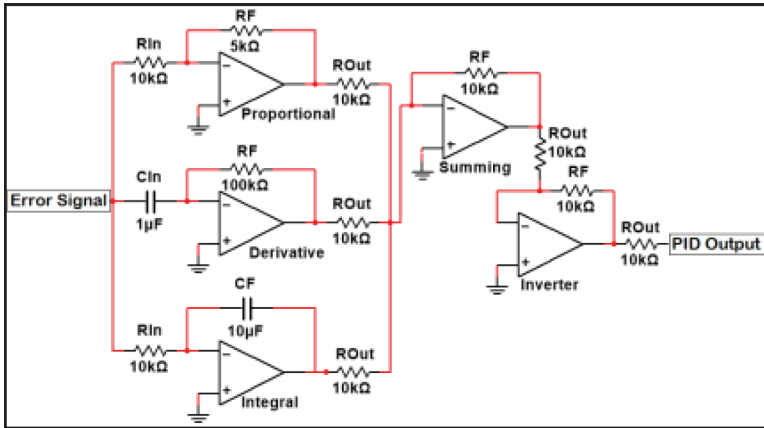

Figure 4: Simplified PID Circuit

The signal from each op-amp configuration is then routed through a summing amplifier and then an inverting amplifier to produce the final output of the controller. Depending on the controller, the signal is routed back to either the piezoelectric disk or thermoelectric cooler to adjust actuation. The goal is to improve system operation by reducing the feedback and therefore

$$\begin{aligned}
 \text{Proportional: } V_{out} &= -V_{in} \frac{R_f}{R_{in}} \\
 \text{Derivative: } V_{out} &= -R_f C_{in} \frac{dV_{in}}{dt} \\
 \text{Integral: } V_{out} &= -\frac{1}{R_{in} C_f} \int V_{in} dt
 \end{aligned}$$

Figure 5: Op-amp Configuration Gain Equations [18]

reducing the error signal provided to the PID controller. The process of measuring feedback and controlling the actuation using the feedback is continually looped in order to maintain proper system operation (Figure 4).

The design of a PID controller is concerned with the appropriate transient response of the signal used to control each

Op-Amp	Rise Time	Settling Time	Steady-state Error	Overshoot
Proportional	Decrease	Negligible	Decrease	Increase
Integral	Decrease	Increase	Decrease	Increase
Derivative	Negligible	Decrease	Negligible	Decrease

**Figure 6:** Op-Amp Configurations Transient Response Characteristics [21]

device. Adjusting the voltage gain of each op-amp configuration improves various characteristics of this response in order to reduce rise time, settling time, steady-state error, and overshoot with respect to the desired set point (**Figure 5**). [19,20]

A higher overall gain in the system will reduce the settling time, but will increase steady-state error. The differentiator, integrator and proportional op-amp configurations can be used cooperatively as lead-lag compensation to improve the transient response (**Figure 6**). [21]

Deciding which characteristic is more important is dependent on design considerations. For example, temperature does not necessarily change abruptly, considering that the ambient temperature of the lab is already regulated. The controller, therefore, does not need to provide adjustments as quickly because the acquired feedback is relatively slow to respond. On the other hand, the wavelength of the laser can change very abruptly

$$\begin{aligned}
 u(t) &= K_p e(t) + K_i \int e(\tau) d\tau + K_d \frac{de(t)}{dt} \\
 \mathcal{L}(u(t)) = U(s) &= \frac{K_d s^2 + K_p s + K_i}{s}
 \end{aligned}$$

**Figure 7:** PID Output Equations [21]

compared to the level of precision required; the controller must therefore be able to anticipate this and provide correction much more quickly.

The output of the PID,  $u(t)$ , can be described with an error function,  $e(t)$ , and gains coefficients to represent the gain of each

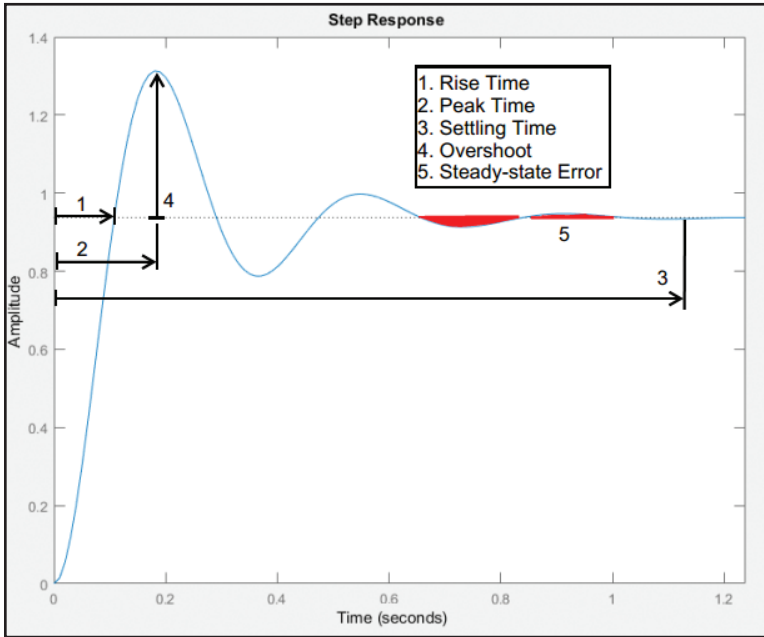

Figure 8: Example Transient Response Characteristics for Transfer Function  $\frac{300}{s^2+10s+320}$

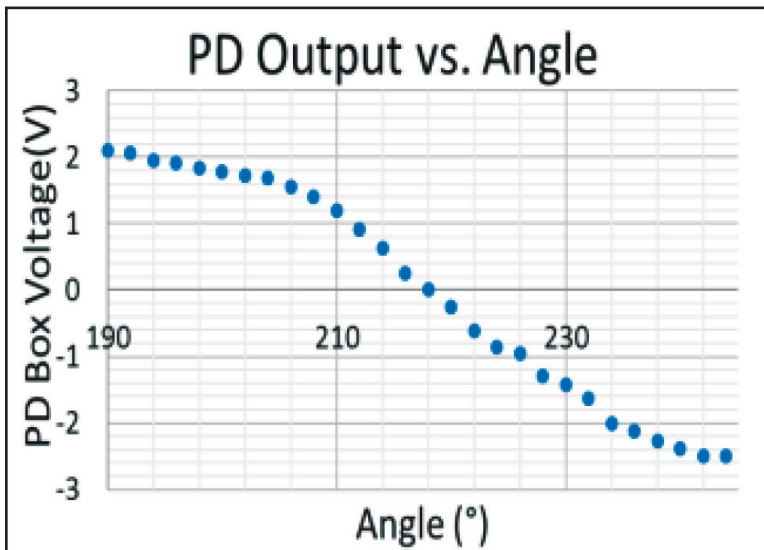

Figure 9: Photodiode Amplifier Output vs. Angle(°)

op-amp configuration. One way to tune the controller design to the correct gain settings is by transforming this equation into the Laplace domain, where it is easier to deal with in Matlab (**Figure 7**).

Using this transformation process, the PID can be tuned by adjusting the gain values and plotting the result. It is most appropriate to start with the proportional gain to reach a response close to the set point. The integral gain is adjusted to minimize steady-state error as much as possible. Lastly, the derivative gain is adjusted to reduce overshoot, although this is not as important (**Figure 8**).

## RESULTS

### Photodiode Amplifier Feedback Test

We built a setup to test the photo diode circuit, which used the following optical components: a diode laser in conjunction with a density filter to adjust light intensity, a half-wave plate to adjust phase between the perpendicular components of the light, and a polarizing beam cube to separate the beam into two individual beams. This setup allowed us to measure the difference in power between the two beams and the associated voltage output of the

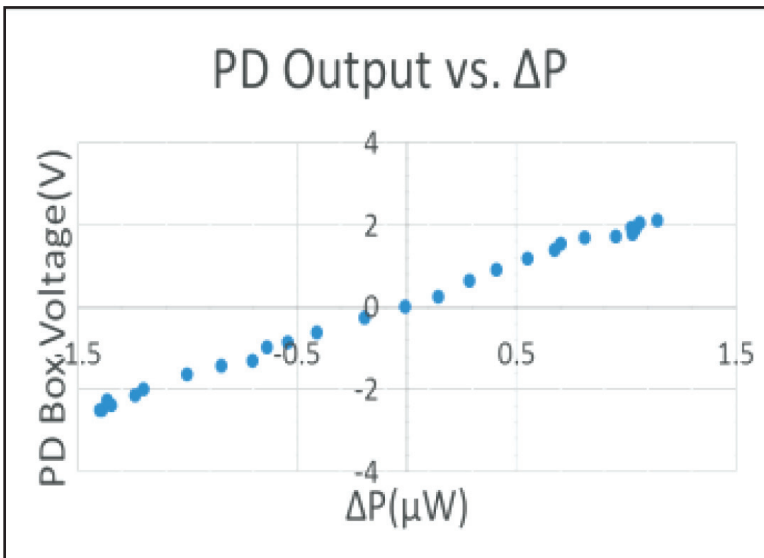

**Figure 10:** Photodiode Amplifier Output vs.  $\Delta P$  ( $\mu W$ )

photo diode circuit at various phase angles, effectively mimicking the final configuration (**Figures 9 and 10**).

**Figure 9** shows how the voltage changes in regards to the phase angle between the perpendicular components of the incoming light. The relationship of the two quantities should be that of a sine function which seems to be apparent by the output of the photodiode circuit.

The relationship between power and voltage is linear, thus the output of the photodiode circuit should mirror the anticipation. **Figure 10** shows the linear trend involved with these data points.

### Temperature Controller Test

Temperature change inside the ECDL enclosure needs to be kept constant over an extended period of time. The correct signal response and settling time does not need to be as quick as the response for the wavelength controller. This is because the

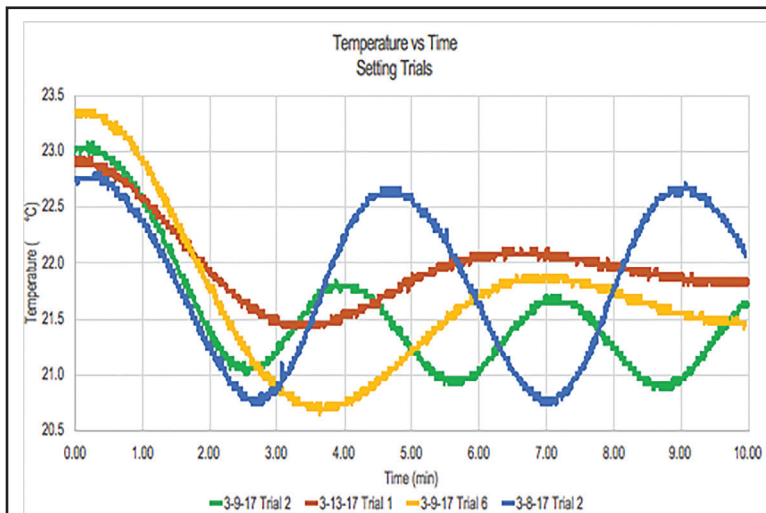

**Figure 11:** Temperature vs. Time trials of the different PID settings of the temperature controller [David Yudowin].

environment in the lab will already be regulated, so any changes that do occur will not be abrupt. Once the internal temperature is steady it will be much easier to regulate.

There is some level of experimentation that needs to be accomplished to reach the desired settings for steady response. This involves altering the settings on the controller

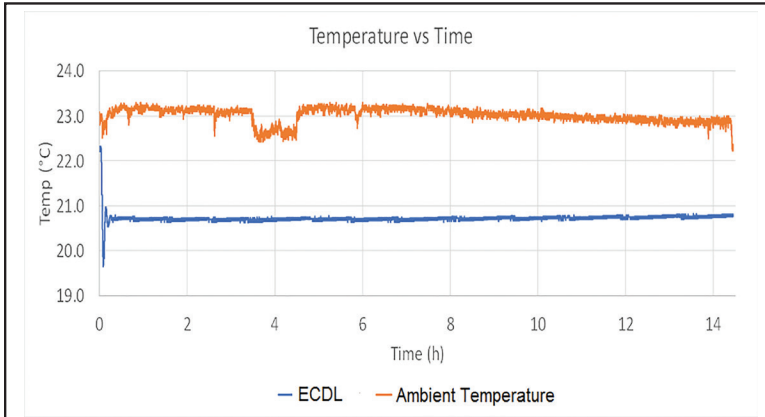

**Figure 12:** Temperature vs Time Stabilization of ECDL and Ambient Room Temperature [David Yudowin]

itself and testing each to see which is more desirable. Each of the settings corresponds to the coefficients of the PID equation. The proportional setting is the most significant to reaching the set point, followed by the integral setting to reduce steady state error. Lastly, the derivative setting is changed to reduce overshoot (**Figure 11**).

This graph represents four 10-minute trials to show the different PID settings of the temperature controller. Just by looking at the different trials, characteristics of the transient response such as overshoot, settling time, and steady-state error vary. Some trials continue to oscillate while others look as though they will reach steady state around the 9-minute mark (**Figure 12**).

Using the desired settings determined previously, we plotted a much longer trial to see how the temperature compares to the ambient temperature in the room. There is initial oscillation of the internal temperature of the ECDL, but it settles relatively quickly. There is a significant disturbance in the ambient temperature around the 4-hour mark, but the internal temperature of the ECDL maintains temperature.



## CONCLUSION

In order to properly design and implement a control system for an ECDL, concepts involving theory of diode lasers, optical feedback, electronic feedback, and electronic control systems must be understood and implemented. Our ECDL system, when completed, will provide a precise frequency probe of the atomic level structure of rubidium by exciting the valence electrons. Rubidium is desired because it only contains one electron in its valence shell and the excitation wavelength is that of commonly manufactured laser diodes, 780 nm.

The physical construction of the Littrow configuration provided a means of optical feedback via an external cavity and diffraction grating. The laser's stability was increased by reflecting the 1<sup>st</sup> order beam off the diffraction grating back into the laser semiconductor material.

In order for this stability to translate to efficiency, an electronic control system was implemented. Two types of feedback, temperature and optical, need to be controlled with two separate PID controllers in order to maintain the desired operating temperature, and the desired angle of diffraction in the Littrow configuration. Our results at present show that our system provides stable temperature regulation over a 10-hour period, and a capability to amplify laser output as use for electronic feedback.

The controller for the wavelength of the ECDL still needs to be constructed and tested. Once this is accomplished the complete system can be assembled. At this point our ECDL will be used as an absorption spectrometer that will provide the capability to observe the absorption spectra associated with the level structure of rubidium gas. Through the use of an IR viewer or oscilloscope, the attenuated single-beam absorption line from the photo diode circuit can be observed to determine if mechanical, electrical, or thermal stability adjustments must be made. Further circuitry can also be implemented to improve this process. After saturated absorption peaks have been observed they can be compared to structures of known ground and excited states. The wave properties of the observations, such as widths and resolution, are determined by the electronic inputs and can be adjusted as such.

## REFERENCES

- Macadam, K. B., Steinbach, A., & Wieman, C. (2008). A narrow-band tunable diode laser system with grating feedback, and a saturated absorption spectrometer for Cs and Rb. *Collected Papers of Carl Wieman*, 665-678. doi:10.1142/9789812813787\_0091
- RSC (n.d.). Rubidium - Element information, properties and uses. Retrieved May 19, 2017, from <http://www.rsc.org/periodic-table/element/37/rubidium>
- Dingh, J., Dolph, P. A., & Tobias, W. A. (2008, April 23). Alkali metal vapor pressures & number densities for hybrid spin exchange optical pumping. Retrieved May 19, 2017, from <https://people.nsl.msui.edu/~singhj/docs/vp195.pdf>
- Nyamuda, G. P. (2006). Design and Development of an External Cavity Diode Laser for Laser Cooling and Spectroscopy Application. Retrieved February 15, 2017, from [http://www.holographyforum.org/data/pdf/aa-Collection\\_a\\_k/aa-Laser/aa\\_ECDL/Nyamuda-Design\\_and\\_development\\_of\\_ECDL.pdf](http://www.holographyforum.org/data/pdf/aa-Collection_a_k/aa-Laser/aa_ECDL/Nyamuda-Design_and_development_of_ECDL.pdf)
- Metcalf, Harold. "Laser Cooling and Magnetic Trapping of Neutral Atoms." *Methods of Laser Spectroscopy* (1986): 33-40. Web.
- Moloney, J., Hader, J., & Koch, S. (2007). Quantum design of semiconductor active materials: laser and amplifier applications. *Laser & Photonics Review*, 1(1), 24-43. doi:10.1002/lpor.200610003
- Davis, C. C. (2005). Lasers and electro-optic devices. Retrieved May 19, 2017, from <http://www.ece.umd.edu/~davis/ENEE496.html>
- RP Photonics. (n.d.). Semiconductor lasers. Retrieved May 19, 2017, from [https://www.rp-photonics.com/semiconductor\\_lasers.html](https://www.rp-photonics.com/semiconductor_lasers.html)
- Georgia Tech University. (n.d.). Measuring the hyperfine levels of rubidium using saturated absorption spectroscopy. Retrieved March 14, 2017, from <http://advancedlab.physics.gatech.edu/>
- Steck, D. A. (2013, September). Rubidium 85 D Line Data. Retrieved May 19, 2017, from <http://steck.us/alkalidata/rubidium85numbers.pdf>
- Steck, D. A. (2013, September). Rubidium 87 D Line Data. Retrieved May 19, 2017, from <http://steck.us/alkalidata/rubidium87numbers.pdf>
- Paradis, E., Zigo, S., Hu, K. Z., & Raitel, G. (2012). Characterization of laser cooling in a high-magnetic-field atom trap. *Physical Review A*, 86(2). doi:10.1103/physreva.86.023416
- Fan, Haoquan, Santosh Kumar, Jonathon Sedlacek, Harald Köbler, Shaya Karimkashi, and James P. Shaffer. "Atom Based RF Electric Field Sensing." *Journal of Physics B: Atomic, Molecular and Optical Physics* 48.20 (2015): 202001. Web.
- Hawthorn, C. J., Weber, K. P., & Scholten, R. E. (2001). Littrow configuration tunable external cavity diode laser with fixed direction output beam. *Review of Scientific Instruments*, 72(12), 4477-4479. doi:10.1063/1.1419217
- Hardy, E. (2016, September 06). Optical feedback in lasers. Retrieved May 19, 2017, from <http://mylaserspectrum.com/2016/09/optical-feedback-lasers/>
- Thorlabs. (n.d.). Choosing a Collimation Lens for Your Laser Diode. Retrieved May 19, 2017, from <https://www.thorlabs.com/tutorials.cfm?tabID=f7ed0dd5-3f31-4f84-9843-e0f7ac33f413>
- UNSW. (n.d.). Diffraction gratings and spectroscopy. Retrieved May 19, 2017, from <http://www.animations.physics.unsw.edu.au/jw/light/diffraction-grating-spectroscopy.html>

- Nise, N. S. (2015). Control systems engineering. Hoboken: J. Wiley & Sons.
- eCircuit Center. (2004). The Op Amp PID Controller. Retrieved March 14, 2017, from [http://www.ecircuitcenter.com/Circuits/op\\_pid/op\\_pid.htm](http://www.ecircuitcenter.com/Circuits/op_pid/op_pid.htm)
- Thorlabs. (n.d.). PID Basics. Retrieved March 14, 2017, from <https://www.thorlabs.com/tutorials.cfm?tabID=5dfca308-d07e-46c9-baa0-4defc5c40c3e>
- UMICH. (n.d.). Introduction: PID Controller Design. Retrieved May 30, 2017, from <http://ctms.engin.umich.edu/CTMS/index.php?example=Introduction&ion=ControlPID>