



GFDM FOR NEXT GENERATION WIRELESS COMMUNICATION SYSTEM

¹Abhishek Kumar, ²Sourabh Santosh

¹Department of ECE, BIT Mesra, Ranchi, Jharkhand, India-835215

²Department of ECE, IIT(ISM) Dhanbad, Jharkhand, India- 826004

Email: abhishekec02@gmail.com, sourabhdns@gmail.com

Article History: Submitted on 25th January, Revised on 8th February, Published on 4th March 2018

Abstract. In modern scenarios, there are several applications of OFDM, but it also has some demerits like sensitive to Carrier Frequency Offset (CFO), high Peak to Average Power Ratio (PAPR), and timing offset large. Out Of Band (OOB) and low spectral efficiency due to cyclic prefix per symbol insertion. To diminish and discard above problems, new multiplexing technique is required for next generation wireless communication i.e. GFDM. GFDM is becoming popular day by day due to flexibility in pulse shape as well as single cyclic prefix in a multipath channel and which makes it eligible for the 5th generation technology. This paper deals with an overview of a GFDM and presents a comparative study between OFDM and GFDM.

Keyword. Wireless Communication; Peak to Average Power Ratio; OFDM; GFDM; Inter Symbol Interference; Inter Carrier Interference.

INTRODUCTION

Modern societies are completely attached with mobile communication because it is a major part of wireless communications such as wireless sensor network, static or dynamic ad-hoc network [1-3]. All nodes of the network scatter in two ways such as heterogeneous or homogeneous and travel arbitrary due to dynamic behavior of the network [4-9]. It needs high data rate, low bit error rate, high spectral efficiency. Various generation of communication have revolutionized the way where people connect to each other to achieve its own goals. Each wireless communication consists of some or more uncertainties related issues that generate several types of problem such as several attacks and breakage of link, etc. [10-13]. The scenarios of 4G a network, OFDM is widely adopted solution in communication system. It is rapidly used in several applications such as disaster management, e-commerce [14], intelligence system, etc. with the help of some techniques like artificial intelligence [15], soft computing [16-18], mathematical modelling [19], etc. It efficiently utilizes system bandwidth based on subcarrier orthogonality as well as inter symbol interference mitigation due to the narrowband characteristics in each subcarrier [20]. It has become an important technique which distributes a high speed data to multiple low speed data rate.

OFDM is progressively used in high mobility wireless communication system, i.e. mobile WiMAX (IEEE 802.16e) and 3GPP's UMTS Long Term Evolution (LTE) [21]. OFDM present a prohibitive low spectral efficiency for cyclic prefix per symbol. In OFDM, rectangular pulse shaping filter used at the transmitter and reason of higher PAPR is the random sum of the phase subcarriers. Various PAPR reduction techniques and algorithm is formed. The set of advantages in OFDM given below:

- Computationally efficient to implement the modulation and demodulation function Resistant to frequency selective fading.
- Mitigating ISI in frequency selective channel.
- Adaptation for serve channel conditions.
- Elimination of need for equalizer.

The set of disadvantages in OFDM is given below [22]:

- Sensitive to Doppler effect.
- Sensitive to frequency synchronization problems.
- Large dynamic range amplitude.
- Sensitive to carrier frequency offset, timing offset.
- High PAPR.
- High OOB radiation.
- Bandwidth inefficiency.

Due to above problems with OFDM, it becomes unsuitable for next generation wireless communication. Its flexibility allows covering CP-OFDM, SC-FDE which is shown in Fig. 1. To reduce and remove its difficulties, GFDM is proposed

and explored for 5G networks [23]. Its waveform gives additional features in the upcoming cellular systems. The applications of machine to machine communications and spectrum with main devotion to asynchronous exploration of non-continuous bandwidth and low duty cycle transmission. The cycle prefix and length pulse shaping help to eliminate inter carrier interferences and inter symbol interferences. It is better low burst applications.

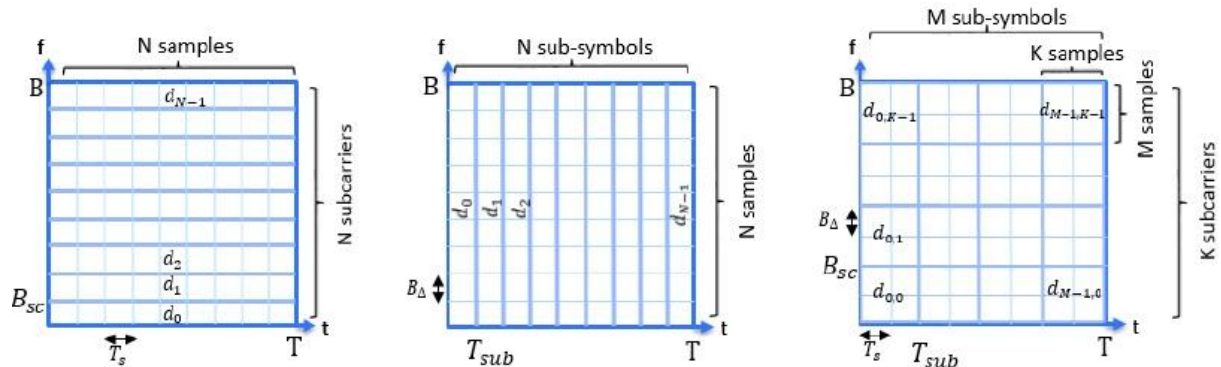

Figure 1. Partitioning of frequency and time of several multiplexing schemes. (a) K=N subcarriers and M=1 sub-symbol, (b) K=1 subcarrier and M=N sub-symbols, (c) K=4, M=4 and N=16.

The rest of the manuscript is arranged as given. In section II, presents about the mathematical description of GFDM and OFDM. Then, simulation result in term of BER, Multiplication complexity between OFDM and GFDM in section III. Finally, conclusion and directions for future scope of research are given in Section IV.

MATHEMATICAL DESCRIPTION

OFDM

OFDM is a type of multicarrier transmission scheme where high rate single data stream is transmitted over a number of low data rate parallel subcarriers. Because of the low rate parallel subcarriers, the symbol duration increases with reduction in effect of multipath delay spread on the signal. QAM or PSK modulation is used. These parallel discrete frequency components are sent to Inverse Fast Fourier Transform (IFFT) which convert these discrete frequency component in corresponding discrete time components. These signal passed through a parallel to serial converter which convert the signal in a serial form for transmission. Thereafter Cyclic Prefix (CP) is added to remove ISI. The mathematical description of an OFDM system is as follows:

$$S[n] = \sum_{k=0}^{N-1} d_k \exp(j2\pi \frac{nk}{N}) \quad (1)$$

Where, $s[n]$, k and N is the transmission symbol of n^{th} time sample, subcarrier index and total number of subcarrier, respectively as shown in Fig. 2.

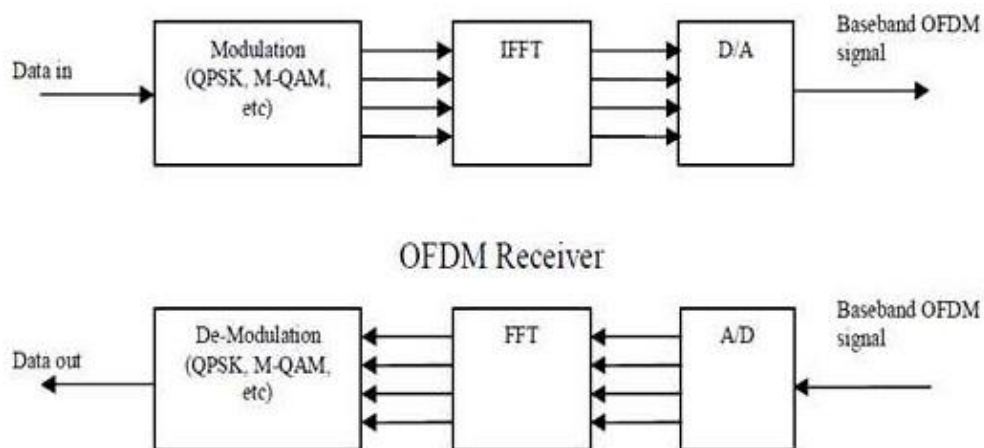

Fig. 2.

After passing through Additive White Gaussian Noise (AWGN) channel, the transmitted OFDM signal is received and down converted to baseband. Thereafter passed through low pass filter to remove high frequency component and then CP is removed. Then signal converted serial to parallel and FFT operation done on these time domain signal. The FFT output is parallel to serial converted and passed through the demodulator which maps the signal to produce the input signal [24].

GFDM

Considering the block diagram depicted in figure, a data source provides bits of data to the vector \vec{b} . Then data is encoded and mapped, i.e. J-QAM is the modulation that will be used for this work, to symbols of 2^μ -valued complex constellation where μ is the modulation order. As a result of this, we get vector \vec{d} , which is the data block containing N elements. Those elements can be split into K subcarriers and M sub-symbols which relate as $N=K.M$ (M sub-symbols and K subcarriers compose each GFDM symbol), leading to $\vec{d}=(\vec{d}_0^T, \vec{d}_1^T, \dots, \vec{d}_{M-1}^T)^T$ where each vector is $\vec{d}_m=(d_{0,m}, d_{1,m}, \dots, d_{K-1,m})^T$. Every individual corresponds to the data transmitted on the k^{th} subcarrier and in the m^{th} sub-symbol of the block.

All these data symbols are transmitted respectively with a corresponding pulse shape in time and frequency domain as follows, where n is denoting the sampling index. Each $p_{k,m}[n]$ is a time and frequency shifted version of the prototype filter $p[n]$, where mod N operation makes $p_{k,m}[n]$ a circularly shifted version of $p_{k,0}[n]$ and the exponential performs the shift in frequency domain [25-28]. The transmitted signal with GFDM is given as follows.

$$X[n]=\sum_{m=0}^{M-1} \sum_{k=0}^{K-1} d_{k,m} p[(n-mK)N]g_k[n] \quad (2)$$

where M=number of GFDM symbols in a GFDM frames, K=number of subcarrier. $d_{k,m}$ is the data notation transmitted at the k^{th} subcarrier and m^{th} GFDM notations in GFDM frame. x =input alphabet (transmitted) of the source such that $d_{k,m} \in x$, $p[n]$ =pulse shaping filter in pulse of response n, $p[(n-mK)N]$ =circular shift $p[n]$ by mK with modulo N shown in Fig. 3, $g_n[n]$ =complex multiplier term which shifts the base band to k^{th} subcarrier location which is shown in Fig. 3.

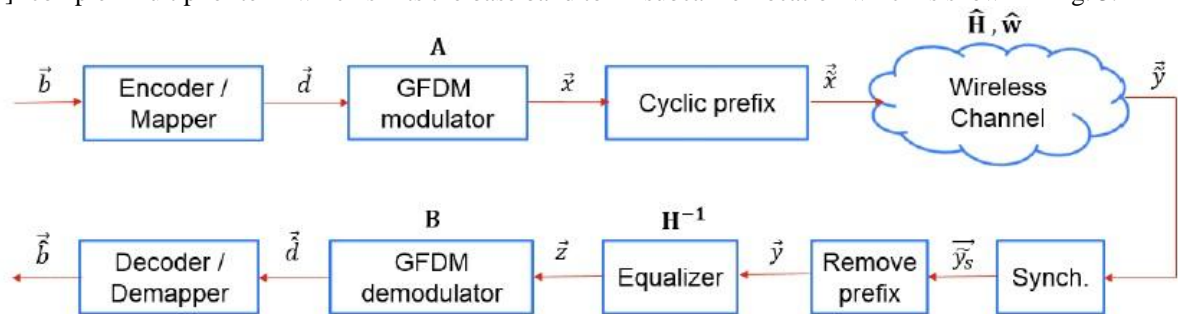

Figure 3. Transceiver block diagram.

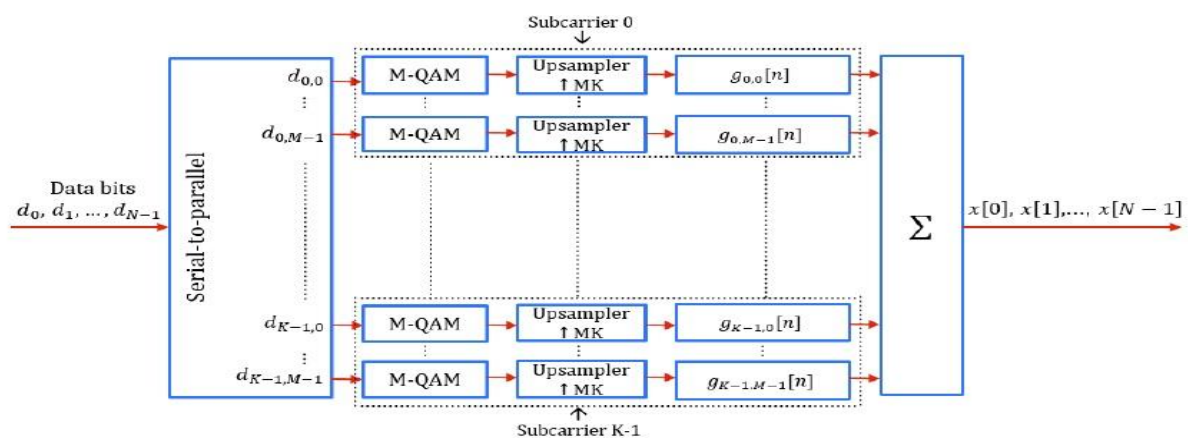

Figure 4. Modulator of GFDM as block diagram.



$$x = \begin{bmatrix} x(0) \\ x(1) \\ \vdots \\ \vdots \\ x(N-1) \end{bmatrix} \quad (3)$$

$$d = \begin{bmatrix} d_{0,0} \\ d_{1,0} \\ \vdots \\ \vdots \\ d_{k-1,0} \\ d_{0,1} \\ d_{1,1} \\ \vdots \\ \vdots \\ d_{k-1,m-1} \end{bmatrix} \quad (4)$$

$$g_n[n] = e^{-j2\pi \frac{kn}{N}} \quad (5)$$

$$A = \begin{bmatrix} p_{0,0(0)} & p_{1,0(0)} & \dots & \dots & p_{K-1,0(0)} \\ p_{0,1(1)} & p_{1,1(1)} & \dots & \dots & p_{K-1,1(1)} \\ \vdots & \vdots & \dots & \dots & \vdots \\ \vdots & \vdots & \dots & \dots & \vdots \\ p_{0,M-1(N-1)} & p_{1,M-1(N-1)} & \dots & \dots & p_{K-1,M-1(N-1)} \end{bmatrix} \quad (6)$$

The result of the GFDM transmitter, $x[n]$, in Figure, can be shown next subsection. Defining, $p_m[n] \triangleq p[(n-mk)_N]$, can be expressed as:

$$x[n] = \sum_{m=0}^{M-1} \sum_{k=0}^{K-1} d_{k,m} p_m[n] g_k[n] \quad (7)$$

The received signal from GFDM transmitter which has gone through the channel, after CP removal can be shown as,

$$R = Hx + v \quad (8)$$

where v is the complex additive white Gaussian noise (AWGN) vector, i.e. $v \sim \mathcal{CN}(0, p_v^2 \mathbf{I}_{MN})$, p_v^2 is the noise variance, and $H = \text{circ}(\tilde{h})$ is the zero padded version of \tilde{h} to have the same length as x . Due to the fact that H is a circulant matrix, an FDE procedure can be performed to compensate for the multipath channel impairments.

The symbol $y_{cp}[n]$ stands for samples from the sampler in the RF front end block, whose cp portion is omitted to get $y[n]$. Subsequently, equalizer block that equalizes the effect of the channel with estimated channel value provided by the channel estimation block. The notation $y_{cp}[n]$ represents equalized signal which is fed to the GFDM demodulator. This yields the soft data bits. The hard decision is made by the slicer. The single tap equalization technique is given by:

$$y_{cp}[n] = \text{IFFT} \left[\frac{\text{FFT}[y[n]]}{\text{FFT}[h_c[n]]} \right] \quad (9)$$

GFDM symbols having a block structure with a cyclic prefix that results in a circulant matrix Equalized sampled are fed to the GFDM demodulator [29-30] after equalization. The word demodulator is replaced by receivers. The types of receivers may be Matched Filter (MF), Zero-forcing (ZF).

MF Receiver

To implement MF GFDM, the correlator receiver is used. Here each correlator is matched with different subcarrier in several time slot. After multiplication of the received signal $y_{eq}[n]$ with circularly shifted versions of the pulse shape $p[n]$ and complex exponentials, where summation is done over an interval of MK and then result is sampled. In a correlation receiver, classical integrate-dump operation used. In such an operation in fact corresponds to multiplication of the equalized version of the received signal $y_{eq}[n]$ with A^H . In this case the vector of estimated soft bits, \hat{d}_{MF} can be expressed as:

$$\hat{d}_{MF} = A^H \cdot y_{eq}[n] \quad (10)$$

ZF Receiver

The ZF receiver is simply the multiplication of by the inverse of the matrix A. In this case:

$$\widehat{d}_{ZF} = A^{-1} \cdot y_{eq}[n] \quad (11)$$

SIMULATION RESULTS ANALYSIS

Number of Complex Multiplications

Number of Complex multiplications required for different transmitter systems are given in Table 1 and no. of Complex multiplications required for different receiver systems are given in Table 2.

Table 1. Computational Complexity of Different Transmitters [31]

Technique	No. of complex multiplications
OFDM	$\frac{MN}{2} \log_2 N$
GFDM	$(MN)^2$

Table 2. Computational Complexity of Different Receivers [31]

Technique	No. of complex multiplications for AWGN Channel
OFDM	$\frac{MN}{2} \log_2 N$
Direct ZF Receiver for GFDM	$2(MN)^2$
Matched Filter for GFDM	$MN(\log_2 MN + \log_2 M + L + I(2\log_2 M + 1))$

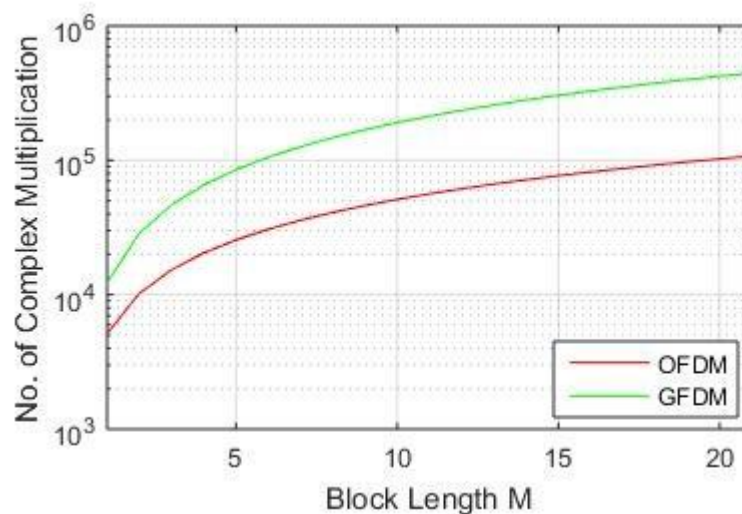

Figure 5. Computational complexity comparison of GFDM transmitter techniques with respect to OFDM in AWGN channel when N=1024, M=1 to 21

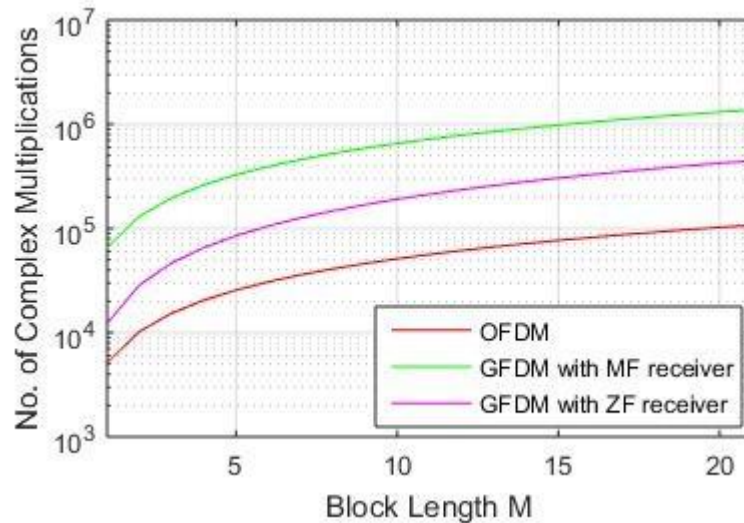

Figure 6. Computational complexity comparison of different GFDM receiver techniques with respect to each other and that of OFDM receiver in AWGN channel when $N=1024$, $M=(1,21)$.

Fig. 5 shows about computational complexity at OFDM and GFDM transmitter. From the graph, transmitter of GFDM is required more number of complex multiplication compared to OFDM with respect to size of block length over AWGN channel. Here, no. of symbol is 1024 and block length varies from 1 to 21.

Fig. 6 shows about computational complexity of receivers of OFDM and GFDM with MF, ZF, and MMSE. From the graph, GFDM with MF receiver is required more complex number of multiplication compared to OFDM and ZF with respect to size of block length over AWGN channel. Here, no. of symbol= $N=1024$ and block length varies from 1 to 21.

SNR vs BER

Here, we have studied the BER performance of different system over AWGN channel. Figs. 7 and 8 shows the BER performance between OFDM system, GFDM system with MF and GDM system with ZF receiver over AWGN channel. Let K is Number allocated subcarriers which is equal to 128, L is number of overlapping subcarriers which is 2, M is number of sub-symbols which is equal to 5, CP length is 128, 16-QAM modulation is used. The self-interference caused by the pulse shaping filter reduces with the reducing the value of roll-off factor. Due to the high roll-off factor, GFDM performance became better. That is because, when $\alpha=0$, the frequency domain of RC filter became closer to rectangle, which will causeless self-interference to the adjacent subcarriers.

The BER may be enhanced by selecting a slow and robust modulation scheme or by line coding scheme or by channel coding schemes or also by selecting strong signal strength [32].

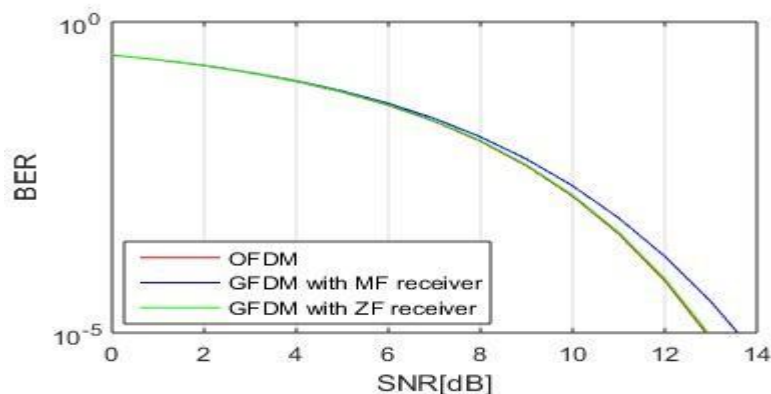

Figure 7. BER vs SNR plot $\alpha=0.3$, RC filter.

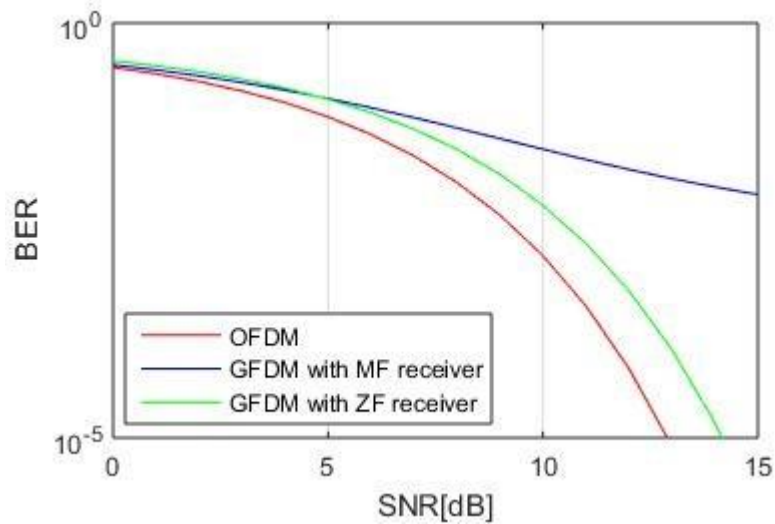

Figure 8. BER vs SNR plot $\alpha=0.3$, RC filter.

Power Spectral Density

Power Spectral Density (PSD) is generally provide the frequency response of a random or periodic signal. It represent where the average power is distributed as a function of frequency. PSD expressions has been the need to predict the in-band and out-of-band radiation which is produced at transmitter. PSD of the signal depends on the characteristics of four signal operations performed at the transmitter side are circular shift operation, cyclic prefix insertion, pulse shaping, interpolation filtering. GFDM flexibility provides advantage over out-of-band distortion. Here, we will discuss about the graph between PSD and frequency. PSD depends on levels of modulation as it raise with raise in levels of modulation.

Here, K is Number allocated subcarriers which is equal to 512, M is number of sub-symbols which is equal to 15, L is number of overlapping subcarriers which is 2, 16-QAM modulation is used. It can be clearly scene that the power consumes on the side lobes is much high in case of OFDM while in case of GFDM more power is consumed on the main lobs. The PSD of an exemplary comparison between OFDM and GFDM is shown in Figs. 9 and 10. It is shown that PSD of an OFDM with rectangular time window is not perfectly flat but reasonably considered flat. The analysis of PSD performances have suggested that GFDM is better than OFDM.

The selection of pulse-shaping filter and its roll-off (α) factor affects the different performance parameters like PSD, PAPR, bandwidth efficiency, SNR, ISI of a modern communication system. So the choice of a proper pulse shaping filter with suitable roll-off factor (α) is an important field to provide reliable and in corrupted communication [33].

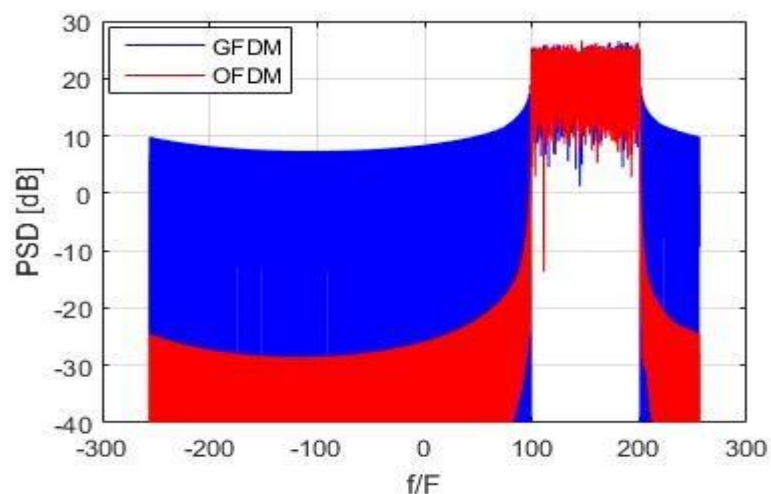

Figure 9. PSD comparison between OFDM and GFDM with RC filter, $\alpha=0.9$.

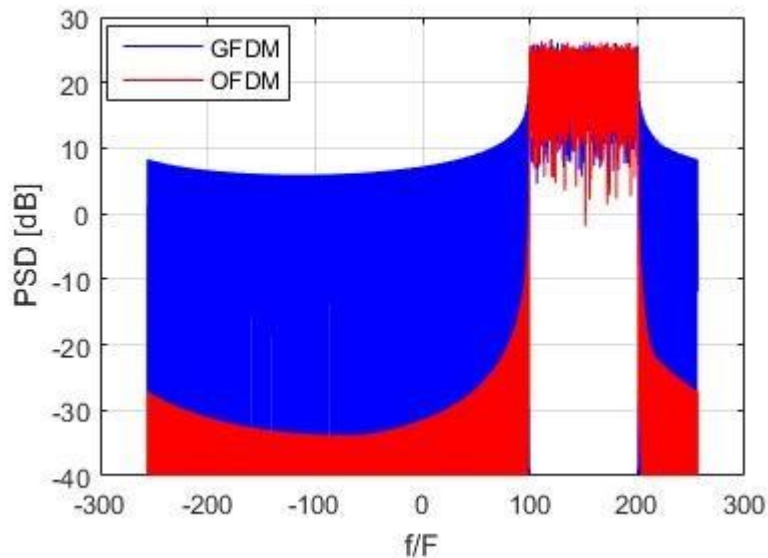

Figure 10. PSD comparison between OFDM and GFDM with RC filter, $\alpha=0.9$.

CONCLUSION

At this time, OFDM is a widely accepted technique mainly because of its advantages like robustness against multipath channels and FFT algorithms based easy implementation. But the scenarios predicted for next generation networks present challenges which OFDM can only address in a limited way. GFDM is a promising waveform candidate for 5th generation technology which gives high spectral efficiency and low out of band radiation which is required for 5G communication. But it still have problem of high PAPR. There are several PAPR reduction techniques proposed for multi carrier multiplexing system. Comparing the simulation results we can conclude that there is a significant performance improvement as we increase the constellation size with normalization. Receiver section is also designed to test the transmitted signal over the channel. AWGN channel is used for modelling and simulation of transmitter and receiver section. All simulation is performed on MATLAB where results shows that comparison between OFDM, GFDM system with MF receiver, GFDM system with ZF receiver for pulse shaping filter with different values of roll off factor (α) in terms of bit error rate performance. Computational complexity for OFDM transmitter, GFDM transmitter, OFDM receiver and different GFDM receivers is performed on MATLAB. At last we compared the existing OFDM system with GFDM system in term of PSD, which is also simulated on MATLAB.

REFERENCES

- [1] A. K. Yadav, S. K. Das and S. Tripathi, "EFMMRP: Design of efficient fuzzy based multi-constraint multicast routing protocol for wireless ad-hoc network," *Computer Networks*, 2017, vol. 118, pp. 15-23, <https://doi.org/10.1016/j.comnet.2017.03.001>.
- [2] S. K. Das, A. K. Yadav and S. Tripathi, "IE2M: Design of intellectual energy efficient multicast routing protocol for ad-hoc network," *Peer-to-Peer Networking and Applications*, 2016, vol. 10, no. 3, pp. 670-687, DOI 10.1007/s12083-016-0532-6.
- [3] S. K. Das and S. Tripathi, "Intelligent energy-aware efficient routing for MANET," *Wireless Networks*, 2016, vol. 24, no. 4, pp. 1572-8196, DOI 10.1007/s11276-016-1388-7.
- [4] S. K. Das and S. Tripathi, "Energy Efficient Routing Protocol for MANET Using Vague Set," in *Proceedings of Fifth International Conference on Soft Computing for Problem Solving*, Springer, 2016, pp. 235-245, DOI: 10.1007/978-981-10-0448-3_19.
- [5] S. K. Das and S. Tripathi, "Energy efficient routing protocol for manet based on vague set measurement technique," *Procedia Computer Science*, 2015, vol. 58, pp. 348-355, doi:10.1016/j.procs.2015.08.030.



- [6] S. K. Das, S. Tripathi, and A. Burnwal, "Intelligent energy competency multipath routing in wanet," in *Information Systems Design and Intelligent Applications*, Springer, 2015, pp. 535-543, DOI: 10.1007/978-81-322-2250-7_53.
- [7] S. K. Das, A. Kumar, B. Das, and A. Burnwal, "Ethics of reducing power consumption in wireless sensor networks using soft computing techniques," *International Journal of Advanced Computer Research*, 2013, vol. 3, no. 1, pp. 301-304.
- [8] S. K. Das, B. Das, and A. Burnwal, "Intelligent energy competency routing scheme for wireless sensor networks", *International Journal of Research in Computer Applications and Robotics*, 2014, vol. 2, no. 3, pp. 79-84.
- [9] S. K. Das, A. K. Yadav and S. Tripathi, "Energy efficient routing formation algorithm for hybrid ad-hoc network: A geometric programming approach," *Peer-to-Peer Networking and Applications*, 2018, pp. 1-27, <https://doi.org/10.1007/s12083-018-0643-3>.
- [10] S. K. Das and S. Tripathi, "Adaptive and intelligent energy efficient routing for transparent heterogeneous ad-hoc network by fusion of game theory and linear programming," *Applied Intelligence*, 2017, pp. 1-21, <https://doi.org/10.1007/s10489-017-1061-6>.
- [11] S. K. Das and S. Tripathi, "Energy efficient routing formation technique for hybrid ad hoc network using fusion of artificial intelligence techniques," *International Journal of Communication Systems*, 2017, pp. 1-16, DOI: 10.1002/dac.3340.
- [12] S. K. Das, S. Tripathi, and A. Burnwal, "Fuzzy based energy efficient multicast routing for ad-hoc network," in *Computer, Communication, Control and Information Technology (C3IT), 2015 Third International Conference on, IEEE, 2015*, pp. 1-5, DOI: 10.1109/C3IT.2015.7060126.
- [13] S. K. Das, S. Tripathi, and A. Burnwal, "Design of fuzzy based intelligent energy efficient routing protocol for WANET," in *Computer, Communication, Control and Information Technology (C3IT), 2015 Third International Conference on, IEEE, 2015*, pp. 1-4, DOI: 10.1109/C3IT.2015.7060201.
- [14] S. K. Das, A. Kumar, B. Das, and A. Burnwal, "Ethics of E-Commerce in Information and Communications Technologies," *International Journal of Advanced Computer Research*, 2013, vol. 3, no. 1, pp. 122-124, doi=10.1.1.300.9397.
- [15] A. Burnwal, A. Kumar, and S. K. Das, "Survey on application of artificial intelligence techniques," *International Journal of Engineering Research & Management*, 2014, vol. 1, no. 5, pp. 215-219.
- [16] S. K. Das, A. Kumar, B. Das, and A. Burnwal, "On soft computing techniques in various areas," *Computer Science & Information Technology (CS & IT)*, 2013, vol. 3, pp. 59-68, DOI : 10.5121/csit.2013.3206.
- [17] S. K. Das, S. Tripathi, and A. Burnwal, "Some relevance fields of soft computing methodology," *International Journal of Research in Computer Applications and Robotics*, 2014, vol. 2, pp. 1-6.
- [18] A. Burnwal, A. Kumar, and S. K. Das, "Assessment of fuzzy set theory in different paradigm," *International Journal of Advanced Technology & Engineering Research*, 2013, vol. 3, no. 3, pp. 16-22.
- [19] A. Burnwal, A. Kumar, and S. K. Das, "Assessment of Mathematical Modeling in Different Areas," *International Journal of Advanced Technology & Engineering Research*, 2013, vol. 3, no. 3, pp. 23-26.
- [20] L. Cimini, "Analysis and simulation of a digital mobile channel using orthogonal frequency division multiplexing," *IEEE transactions on communications*, vol. 33, no. 7, pp. 665-675, 1985.
- [21] B. Farhang-Boroujeny, "Ofdm versus filter bank multi-carrier," *IEEE signal processing magazine*, vol. 28, no. 3, pp.92-112, 2011.
- [22] S. Chen and J. Zhao, "The requirements, challenges, and technologies for 5g of terrestrial mobile telecommunication," *IEEE Communications Magazine*, vol. 52, no. 5, pp.36-43, 2014.
- [23] J. Thompson, X. Ge, H.-C. Wu, R. Irmer, H. Jiang, G. Fettweis, and S. Alamouti, "5g wireless communication systems: prospects and challenges [guest editorial]," *IEEE Communications Magazine*, vol. 52, no. 2, pp. 62- 64, 2014.



- [24] Y. S. Cho, J. Kim, W. Y. Yang, and C. G. Kang, MIMO-OFDM wireless communications with MATLAB. John Wiley & Sons, 2010.
- [25] G. Fettweis, M. Krondorf, and S. Bittner, "Gfdm-generalized frequency division multiplexing," in Vehicular Technology Conference, 2009. VTC Spring 2009. IEEE 69th, pp. 1-4, IEEE, 2009.
- [26] R. Datta, N. Michailow, M. Lentmaier, and G. Fettweis, "Gfdm interference cancellation for flexible cognitive radio phy design," in Vehicular Technology Conference (VTC Fall), 2012 IEEE, pp. 1-5, IEEE, 2012.
- [27] R. Datta, N. Michailow, S. Krone, M. Lentmaier, and G. Fettweis, "Generalized frequency division multiplexing in cognitive radio," in Signal Processing Conference (EUSIPCO), 2012 Proceedings of the 20th European, pp. 2679-2683, IEEE, 2012.
- [28] N. Michailow, I. Gaspar, S. Krone, M. Lentmaier, and G. Fettweis, "Generalized frequency division multiplexing: Analysis of an alternative multi-carrier technique for next generation cellular systems," in Wireless Communication Systems (ISWCS), 2012 International Symposium on, pp. 171-175, IEEE, 2012.
- [29] I. Gaspar, N. Michailow, A. Navarro, E. Ohlmer, S. Krone, and G. Fettweis, "Low complexity gfdm receiver based on sparse frequency domain processing," in Vehicular Technology Conference (VTC Spring), 2013 IEEE 77th, pp. 1-6, IEEE, 2013.
- [30] A. Farhang, N. Marchetti, and L. E. Doyle, "Low complexity gfdm receiver design: A new approach," in Communications (ICC), 2015 IEEE International Conference on, pp. 4775-4780, IEEE, 2015.
- [31] A. Farhang, N. Marchetti, and L. E. Doyle, "Low-complexity modem design for gfdm," IEEE Trans. Signal Processing, vol. 64, no. 6, pp. 1507-1518, 2016.
- [32] N. Michailow, S. Krone, M. Lentmaier, and G. Fettweis, "Bit error rate performance of generalized frequency division multiplexing," in Vehicular Technology Conference (VTC Fall), 2012 IEEE, pp. 1-5, IEEE, 2012.
- [33] M. Sameen, A. A. Khan, I. Ullah Khan, N. Azim, T. Zaidi, and N. Iqbal, "Comparative analysis of ofdm and gfdm," IJACTA, vol. 4, no. 2, pp. 267-274, 2017.