



PLANNING, DESIGNING AND IMPLEMENTATION OF NETWORK AT CORPORATE LEVEL

¹Kale Rajesh, ²Dabade Akshay, ³Khatri Rahul, ⁴Prof. Nilesh Yadav

^{1,2,3,4}Department of Computer engineering, Bharat Collage of Engineering, Maharashtra, India

Email: kale626@gmail.com

Article History: Received on 15th June 2017, Revised on 14th July, Published on 16th July 2017

Abstract--The computer networking technology has entered almost in all aspects of day to day life. In today's world life has become fast and human does not like to waste their precious time, many technologies have been introduced in market to fulfill human needs. As we written above network technology are entering in all aspect of day to day life. The people want almost all things faster and reliable so we are tried to apply that in our project. We tried to make our project reliable, fast and most important secured.

Keyword--LAN (Local Area Network); WAN (Wide Area Network).

I. INTRODUCTION

Our main objective to achieve communication which should be Faster and secure. Many methods were invented to achieve that objective. For example, Drums, horns were use in Stone Age times, and then came the mail system. One of the greatest inventions was made when Graham Bell invented telephone which has made today's network possible. Computer Network is one of the ways where people communicate and share resources such as songs, movies etc. there are mainly two types of network i.e. peer-to-peer and client-server network. It has made people possible to share expensive resources, such as printer and screen. Communication channels [1]. Computer network is a telecommunication channel with the help of this channel we send and received information such as Text, Audio and video data [2]. Called data network. Internet provide best computer network Service.

A network contains.

1. Performance
2. Reliability
3. Scalability

FACTORS FOR GOOD WIRELESS NETWORK

1. Intra-System Communication:

As per the requirement of the Smart City we develop highly efficient and secure communication system for

emails, chat rooms and video conferencing [3] also many more.

2. Utilization of System: under the team work of three people we utilize the available resources which are specially provided by the highly efficient and secure network like screen and printer and many more.
3. Authentication for Access all data: While access the file data we need the authentication for every time for the security of Sharing files and data.

II. OPPORTUNITY

In the smart city we have to work on the small geographical area having an updated technology for network communication. Establish network range frequency is equal over smart city to each node. Network utilization is not only depends on the size of the parent organization but also the distance between users on the network. Here in this project the challenges for construction and designed for physical components for the LAN and WAN [5][6].

III. SYSTEM REQUIREMENTS

With the help of Requirement we design Network which is achieving the goal. Networking Devices must give maximum efficiency which is help to organization. A Well planned or Designed Network Reduces cost effectiveness and provide 24x7 services [7][8].

This project describes the following requirements:

- Hardware requirements
- Software requirements
- Other requirements

IV. NETWORK DESIGN

The network design follows a Network systems structure and planning. With the help of organization requirement Network analyst design network System.

The analyst reduced the Network traffic which help [4] to increase performance and reduced cost effectiveness of the Network System as shown in fig. 1.

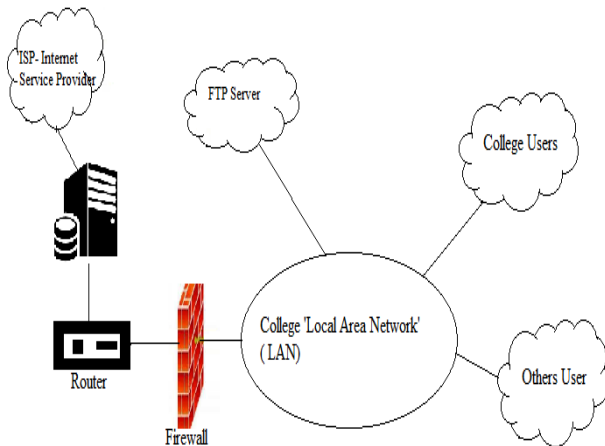

Figure 1. College Network Representation

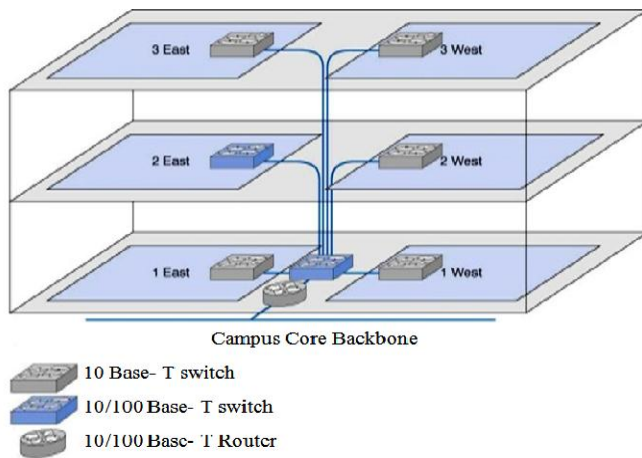

Figure 2. Campus Core Backbone

V. IMPLEMENTATION

- Using well known models and methodologies can aid in structuring the network implementation tasks and creating an implementation plan. The example is as shown in Fig.2.
- An implementation plan consists of the project and network overview, required tools, and information, as well as the implementation tasks.
- The tasks in the implementation plan provide a detailed explanation of all actions that must be taken in order to configure the network according to requirements.
- Good documentation is a result of good processes and procedures, and includes performance testing and

documentation of results. The Network process is shown in fig. 3.

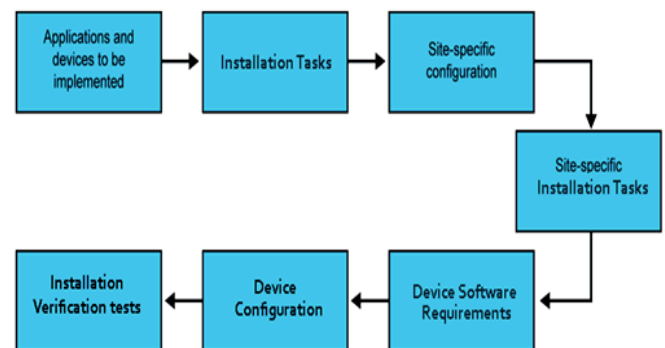

Figure 3. Network Process

VI. CONCLUSION

As the conclusion, this project has successfully reached the aimed and objectives. Before starting this project, our knowledge of networking is not so clear. Though our theory concept was good, but we don't know how to implement a network. But when we started working in our project we learn what is network, how to design, what is server, different types of server, different types of topologies used in networking. Different types of devices such as switch, routers, and media used for that purpose. We use wireless technology. This project helped us to understand network field.

All initial aims of the project have been completed and evaluated successfully.

REFERENCES

- Sybex CCNA 6th Edition (640-802)
- TestKing 640-801 V114.
- 70-642 Windows Server 2008 Network Infrastructure configuration.
- Mcsa windows server 2008 r2- William Panek.
- <https://www.safaribooksonline.com>.
- <https://technet.microsoft.com/en-us/windowsserver/jj554790.aspx>
- <https://technet.microsoft.com/en-us/library/gg597292.aspx>
- Advance in networking Software, IEEE ComSoc.